

Propstore

**BLADE
RUNNER
2049**

Online
Auction



Auction Highlights



Jan 30 - Feb 20, 2025

Ext. Sapper's Farmhouse Set
Behind-the-Scenes Production Still



Online Auction Catalog

This highlights catalog presents select lots from Propstore's *Blade Runner 2049* Online Auction. The full auction catalog contains 200 lots and can be viewed at propstore.com/BR2049. The online catalog features multiple high-resolution photographs for each lot; reviewing the online catalog prior to bidding is highly recommended. The auction lots close on February 20, 2025, and lots close subject to Propstore's extended bidding feature; see online catalog for full details.

Terms & Info

Conditions of Sale

This auction is governed by important stipulated terms, conditions, and reserves. All stipulations can be found at propstore.com/BR2049. Please note, depending on your location, you may be subject to sales tax. A full list of states where sales tax applies can be found in the auction terms.

The majority of items in this auction ship from Propstore's Los Angeles auction; select lots ship from Propstore's London auction and are noted in their descriptions.

Buyer's Premium and Credit Card Fee

A Buyer's Premium of 26% will be added to all winning bids. A fee of 2.5% of the Purchase Price will be added for all orders paid via credit card or debit card.

How To Bid

Online

All bids must be placed online via Propstore's online auction platform. Register today at propstore.com/BR2049

No Reserve Auction

Lots are being sold without a reserve, however lots will not be sold below the starting bid.

Propstore's Certificate of Authenticity

Authenticity is the defining collectible element for original film and television props and costumes. All Lots are authentic assets used in connection with the production of *Blade Runner 2049* (2017). The assets are made available by Propstore in association with Alcon Entertainment, LLC. Each lot comes with a Certificate of Authenticity signed by an Alcon Entertainment Representative. All of our certificates carry multiple security elements to verify authenticity, representing a lifetime guarantee that the item is a genuine piece of cinema history exactly as described. Propstore's complete Terms of Guarantee can be found in the auction Terms & Conditions available at propstore.com.



FRONT COVER IMAGE	BACK COVER IMAGES	
7 K's (Ryan Gosling) Costume with Coat Matched to Arrival at Sapper's Farm Scene	89 K's (Ryan Gosling) Screen-Matched Hero LAPD 2049 Blaster	146 Rick Deckard's (Harrison Ford) Photo-matched Hero Light-Up LAPD 2019 PKD Detective Special Blaster
	90 K's (Ryan Gosling) Closed Light-up Emanator	88 Joi's (Ana de Armas) Turtleneck and Clear Yellow Jacket Ensemble
		136 Rick Deckard's (Harrison Ford) Light-up Binoculars

Propstore CA Bond # 72BSBGU4116



Propstore

BLADE RUNNER 2049 Online Auction



Jan 30 - Feb 20, 2025



propstore.com/BR2049

2025 Alcon Entertainment, LLC. All rights reserved

This catalog includes a selection of Lots only
The complete catalog of 200 Lots is available online

Lots can be viewed by appointment at Propstore's Los Angeles offices from February 1 to Feb 18; contact Propstore to arrange a viewing. Virtual video conference previews are also available by request.

CORE

Community Organized Relief Effort

Alcon Entertainment, LLC and Propstore will donate 10% of the total auction hammer price to CORE.

About CORE: Founded after the 2010 Haiti earthquake by Sean Penn and Ann Lee, CORE (Community Organized Relief Effort) is a global humanitarian organization based in Los Angeles that empowers underserved communities in and beyond crisis. With a focus on equity, CORE provides critical relief to marginalized and vulnerable people, from the frontlines of the COVID-19 pandemic and conflict in Ukraine, to hurricane-impacted states in the US and beyond. CORE's hands-on approach ensures families receive both immediate and long-term support, from cash vouchers and protective resources to comprehensive case management to navigate the aid process as they work to rebuild.

For more information, please visit www.coreresponse.org.





6 Sapper Morton's (Dave Bautista) Environmental Suit and Helmet

Replicant and combat medic Sapper Morton's (Dave Bautista) environmental suit and helmet from BLADE RUNNER 2049. Blade runners, including Officer K (Ryan Gosling) worked for the Los Angeles Police Department (LAPD) to decommission rogue replicants—bioengineered humanoid servants that broke free of their human masters—and retire them. Morton wore his environmental suit and helmet as he worked his farm in the opening scenes of the film.

The costume's components are: • One brown neoprene suit top; • One brown neoprene suit bottom; • One mixed material helmet; • One pair of rubber gloves; • One pair of mixed material boots; • One pair of rubber arm cuffs; • One right leg cuff; • One left leg cuff marked "L" and "13"; • One pair of socks; • One black, white, and gray undershirt; • One pair of black leggings marked "Sapper"; • One production tag

According to production wrap documents, only one of this Sapper costume and helmet was created for the film.

The helmet exhibits minor missing components and the left glove exhibits a tear in the rubber, but the lot remains overall in good condition.

Starting Bid: \$2,500





7
K's (Ryan Gosling) Costume with Coat Matched to Arrival at Sapper's Farm Scene

K's (Ryan Gosling) complete costume with signature coat matched to the arrival at Sapper's Farm scenes, amongst others, from BLADE RUNNER 2049. K, a replicant, is the film's protagonist and title character and a "blade runner" who worked for the Los Angeles Police Department (LAPD) to decommission rogue replicants—bioengineered humanoid servants that broke free of their human masters—and retire them. K wore his costume with its signature dark green, shearling-lined coat throughout the film.

The coat included with this costume screen matches to the one seen when K arrived at Sapper Morton's (Dave Bautista) farm in the film's opening scenes. The coat was worn with the collar-up and matches based on marks and folds in the collar as well as specific stitching lines on the shoulders. Stills shot during the filming of this scene were also used for one of the film's one-sheet posters, depicting K in the fog with his spinner behind him, meaning this specific coat also features on that poster. This same specific coat matches to scenes on K's building rooftop with Joi (Ana de Armas), and was worn by a stunt performer in the Morton farmhouse fight. The jacket is also noteworthy in that the right sleeve is not cut as most seen later in the film are following the arm-stab in the Sapper fight sequence.

The costume's components are: • One shearling collared, black leather insulated coat marked "K" and "Ryan Gosling"; • One unlabeled charcoal sweater with decorative repair stitching; • One long-sleeve undershirt marked "K" at the interior bottom; • One pair of khaki color pants marked "K8"; • One pair of brown leather gloves (Size 8.5) with a knitted yarn liner and decorative repair stitching; • One pair of unmarked black leather and rubber boots.

All components are in production-weathered condition. Fabric tape has been applied to the coat's collar, sometime after the filming of the collar-up scenes, to hold it open a specific way (most of the film's coats had their collars taped or stitched down in this manner.) This indicates it was used or intended for use with the collar opened in addition to the collar-up shots it matches to. The tape is visible when the collar is displayed up but could likely be removed and the adhesive cleaned off.

Starting Bid: \$10,000



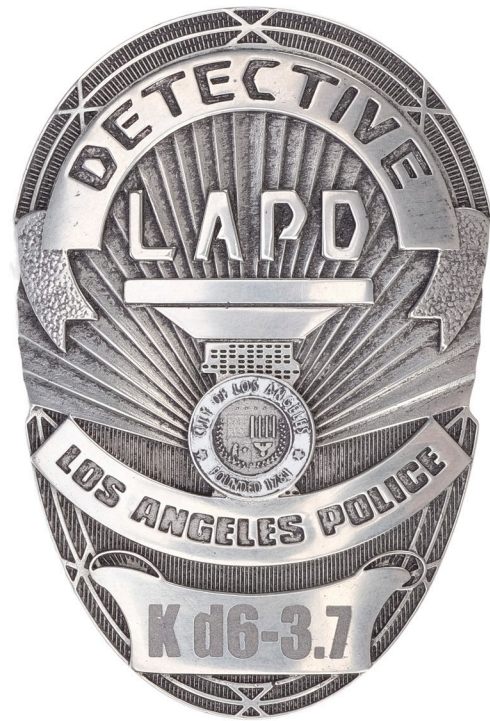

8 K's (Ryan Gosling) Detective Badge

Officer K's (Ryan Gosling) LAPD police badge from BLADE RUNNER 2049. Blade runners, including Officer K, worked for the Los Angeles Police Department (LAPD) to decommission rogue replicants—bioengineered humanoid servants that broke free of their human masters—and retire them. K carried a wallet that housed his LAPD ID card and detective badge (the complete wallet prop is a separate Lot in the auction.)

This lot includes one metal police badge labeled "Detective" and "LAPD" along with the city's seal and the identification "K d6-3.7."

According to production wrap documents, only one detective badge prop was created for the film.

The badge exhibits some wear to the dark shading throughout and minor pitting, but remains overall in good condition.

Starting Bid: \$1,000



9 Sapper Morton's (Dave Bautista) Screen-Matched Jumpsuit with Boots

Replicant and combat medic Sapper Morton's (Dave Bautista) screen-matched jumpsuit with boots from BLADE RUNNER 2049. Replicants were bioengineered humanoid servants that answered to the directions and orders of their human masters in taking on unsavory or dangerous tasks so humans didn't have to. Morton wore his fabric jumpsuit and lace-up boots in the early opening scenes of the film and during his confrontation with K (Ryan Gosling).

The jumpsuit included in this costume screen matches to the one seen when Sapper works on his farm at the start of the film and when he engages in a fight with Officer K in his apartment due to its distinctive discoloration spots above left breast and at the right thigh.

The costume's components are: • Dark brown fabric jumpsuit marked "Sapper Hero 1/3"; • Light gray, short-sleeve T-shirt marked "2/3 Hero"; • One pair of gray socks; • One pair of black leather lace-up ankle boots marked "#13" and "13"; • Three production tags.

The jumpsuit exhibits a small tear at the right thigh and worn and frayed fabric throughout, and the boots exhibit scuffing and surface wear, but the lot remains overall in good condition.

Starting Bid: \$1,000



10 Sapper Morton's (Dave Bautista) Glasses

Replicant and combat medic Sapper Morton's (Dave Bautista) glasses from BLADE RUNNER 2049. Blade runners, including Officer K (Ryan Gosling) worked for the Los Angeles Police Department (LAPD) to decommission rogue replicants—bioengineered humanoid servants that broke free of their human masters—and retire them. Morton put his glasses on when K visited his apartment to retire him in the early scenes of the film.

The lot consists of one pair of gold-color metal glasses and a black glasses case with a snap hinge closure that reads "HERO." The case was used by production to store the glasses.

The glasses exhibit some bending of the temples and the case exhibits minor surface nicks, but the lot remains overall in good condition.

Starting Bid: \$250



11 Sapper Morton's (Dave Bautista) Screen-Matched Distressed Satchel

Replicant and combat medic Sapper Morton's (Dave Bautista) screen-matched distressed satchel from BLADE RUNNER 2049. Replicants were bioengineered humanoid servants that answered to the directions and orders of their human masters in taking on unsavory or dangerous tasks so humans didn't have to. Morton used his satchel to store personal items and tools, and it screen-matches to scenes at the start of the film, including the scene where Morton put his glasses away and took out a knife. Specifically, matching characteristics are present on the wear around the rivets, wear at the zipper pull, and the distressing points at the nylon straps and outer edges of the satchel.

This distressed gray canvas, nylon, and metal satchel features a woven canvas strap, a hanging loop, and leather and metal patches featuring English and foreign language describing its contents.

The satchel exhibits intentional distressing, but remains overall in fair condition.

Starting Bid: \$500



12 Sapper Morton's (Dave Bautista) Metal Knife

Replicant and combat medic Sapper Morton's (Dave Bautista) metal knife from BLADE RUNNER 2049. Blade runners, including Officer K (Ryan Gosling) worked for the Los Angeles Police Department (LAPD) to decommission rogue replicants—bioengineered humanoid servants that broke free of their human masters—and retire them. Morton stabbed Officer K in the arm with the knife when K attempted to retire him.

This lot includes one metal knife that features a blade embedded into a futuristic metal handle with geometric carved out shapes throughout. The knife was custom designed and made for the film.

The lot exhibits nicks and scratches but remains overall in very good condition.

Blade(s) dulled after production in order to be sold as a collectible.

Starting Bid: \$1,000



14
K's (Ryan Gosling) Screen-Matched Light-up Retractable Eye Scanner

Officer K's (Ryan Gosling) LAPD light-up retractable eye scanner from BLADE RUNNER 2049. Blade runners, including Officer K, worked for the Los Angeles Police Department (LAPD) to decommission rogue replicants—bioengineered humanoid servants that broke free of their human masters—and retire them. K used his scanner to identify the replicant Sapper Morton (Dave Bautista), and this lot screen matches to shots where the VFX tracking markers on the light up screen were visible in the film (tracking markers were installed in case the screen needed to be replaced by VFX in the final film; but it was not replaced).

This lot includes one light-up eye scanner with a spring-loaded pop-open mechanism. The scanner's upper component opens when a button is depressed, and another button activates a flashing light-up mechanism.

According to production wrap documents, this is one of three functional electronic eye scanner props created for the film.

The scanner exhibits a slight sticking of the button that opens the scanner, but the lot remains overall in good condition.

Contains electronic elements; please see notice in the Buyer's Guide.

Starting Bid: \$2,500

15
K's (Ryan Gosling) Screen-Matched LAPD Notepad with Transparencies and Pen

Officer K's (Ryan Gosling) LAPD notepad, transparencies, and pen from BLADE RUNNER 2049. Blade runners, including Officer K, worked for the Los Angeles Police Department (LAPD) to decommission rogue replicants—bioengineered humanoid servants that broke free of their human masters—and retire them. The frame screen-matches to the scene in the Spinner after the opening scene at Sapper Morton's (Dave Bautista) farmhouse. The transparency sheet does not match the one seen in the final film but is handwritten, most likely by actor Gosling during alternate takes.

The LAPD notepad consists of a black mixed materials rectangular frame with a picture window that shows an inserted black-and-white replicant intake form; a black metal and plastic pen; and an intake form transparency featuring green markings.

According to production wrap documents, only one LAPD notepad, one pen, and multiple transparencies were created for the film.

The notepad exhibits nicking and light scratches while the see-through bag exhibits creasing and the white logo and writing on the black pen casing is fading in places, but the lot remains overall in good condition.

Starting Bid: \$500

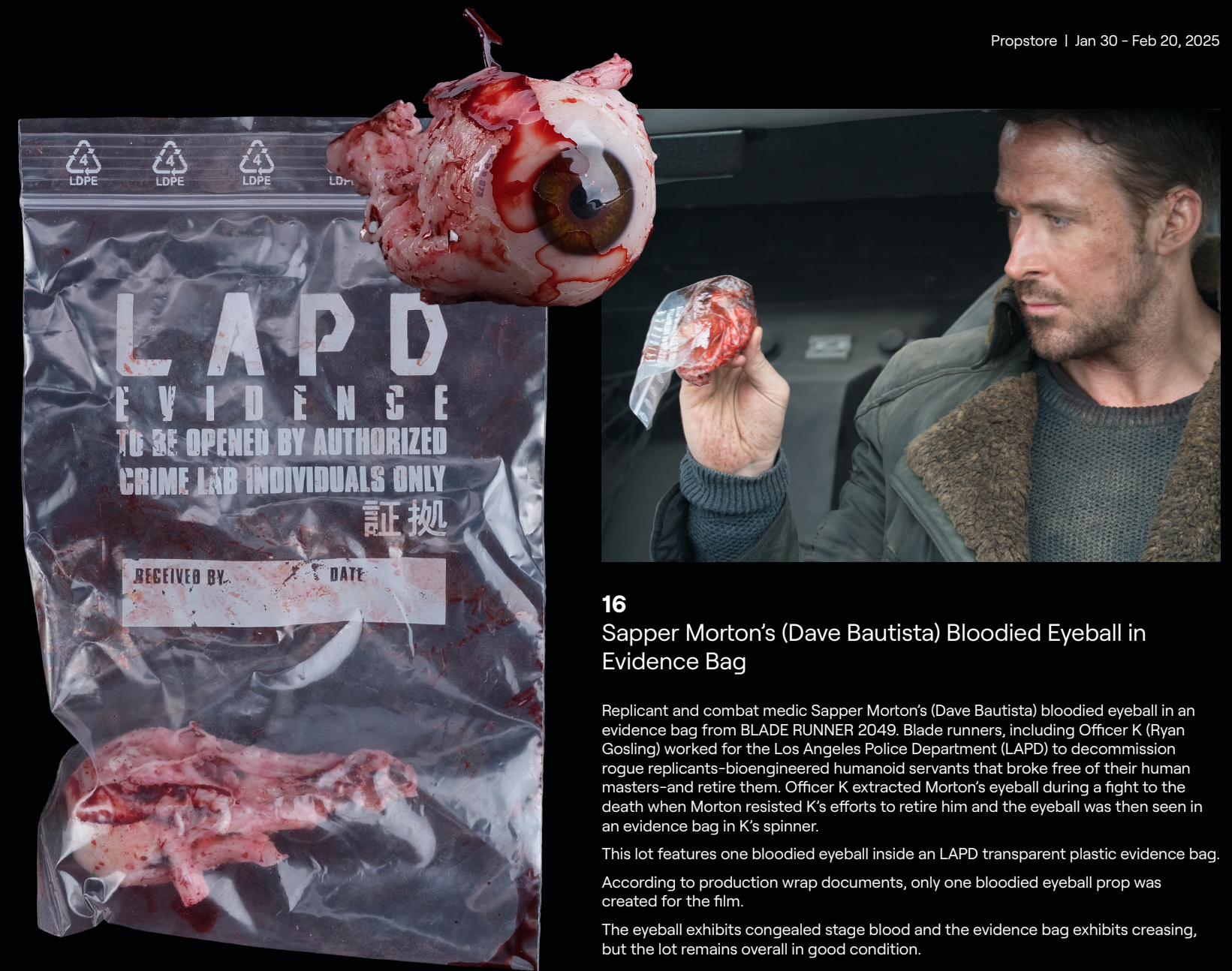
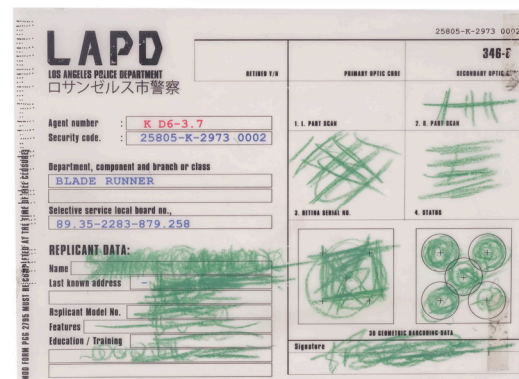

16
Sapper Morton's (Dave Bautista) Bloodied Eyeball in Evidence Bag

Replicant and combat medic Sapper Morton's (Dave Bautista) bloodied eyeball in an evidence bag from BLADE RUNNER 2049. Blade runners, including Officer K (Ryan Gosling) worked for the Los Angeles Police Department (LAPD) to decommission rogue replicants—bioengineered humanoid servants that broke free of their human masters—and retire them. Officer K extracted Morton's eyeball during a fight to the death when Morton resisted K's efforts to retire him and the eyeball was then seen in an evidence bag in K's spinner.

This lot features one bloodied eyeball inside an LAPD transparent plastic evidence bag.

According to production wrap documents, only one bloodied eyeball prop was created for the film.

The eyeball exhibits congealed stage blood and the evidence bag exhibits creasing, but the lot remains overall in good condition.

Starting Bid: \$500



20
Sapper Morton's (Dave Bautista) VFX Knife

Replicant and combat medic Sapper Morton's (Dave Bautista) VFX knife from BLADE RUNNER 2049. Blade runners, including Officer K (Ryan Gosling) worked for the Los Angeles Police Department (LAPD) to decommission rogue replicants—bioengineered humanoid servants that broke free of their human masters—and retire them. Morton used a knife to fight off Officer K, and stabbed him in the arm when K arrived at Morton's farm to retire him.

This lot includes one knife cast in dense urethane that features a detailed handle with geometric carved out shapes throughout. A small piece of reddish cloth tape has been applied to the space where the blade should be to allow for VFX tracking and allows CG artists to animate the blade. The subject is mock-stabbed with a bladeless version for safety then the blade is added in digitally. The knife was custom designed and made for the film.

The lot exhibits a missing blade, nicks, and scratches, but remains overall in good condition.

Starting Bid: \$500

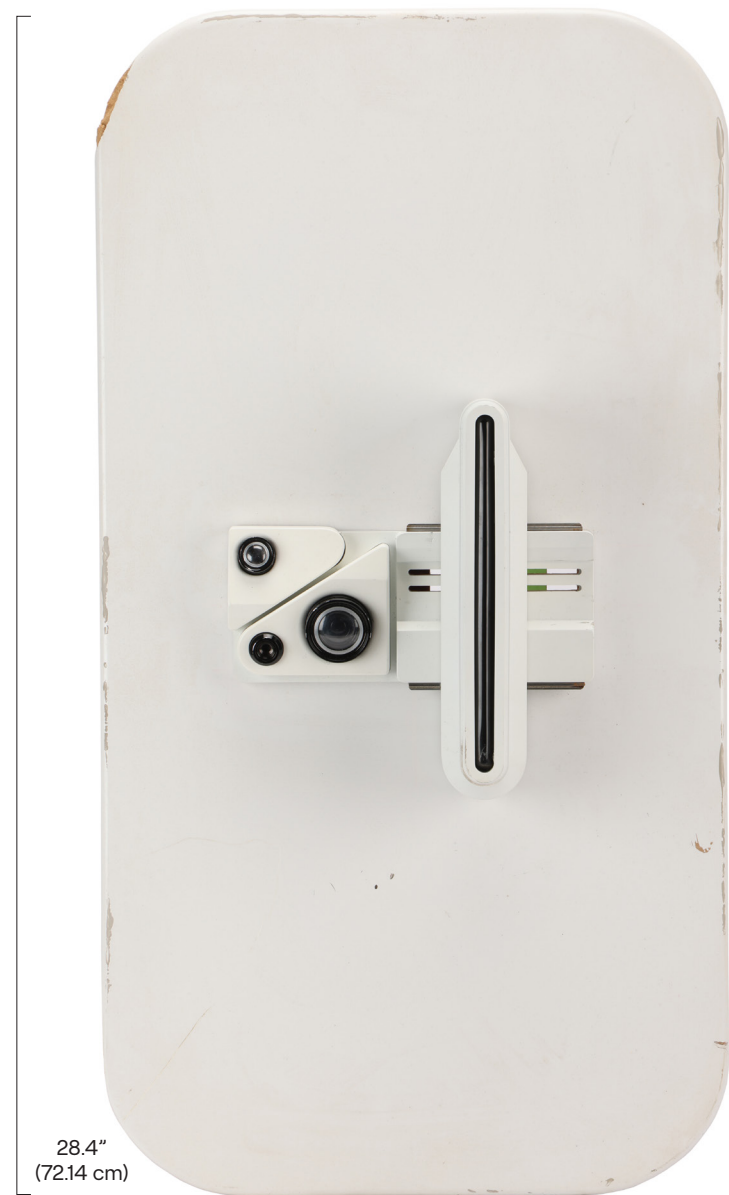

28.4"
(72.14 cm)



21
Screen-Matched Post-Traumatic
Baseline Test Recording Device

A screen-matched post-traumatic baseline test recording device from BLADE RUNNER 2049. The test was administered to Nexus-9 replicant blade runners to test emotional deviance after potentially traumatic events. K (Ryan Gosling) was subjected to the test twice: once after he fought and killed Sapper Morton (Dave Bautista) and again after his mission to find and kill Rick Deckard (Harrison Ford). He was required to recite a very specific speech, leading to memorable scenes within the film. The piece screen matches through the intentional wear and markings around the edge of the device.

The test device sits on a wood backboard and features several lenses and a long scanner that can slide horizontally. There are wires protruding from its back. The device was custom designed and built specifically for the film and was intended to resemble a camera.

According to production wrap documents, only one baseline test recording device prop was created for the film.

It exhibits some wear, most notably a chip on a corner of the background and some additional minor markings, but remains overall in good condition.

This lot is currently located in Propstore's London facility and will ship directly to the Buyer from the London facility. Buyer will be responsible for all shipping and import charges from the UK. Please inquire for additional information.

Starting Bid: \$10,000

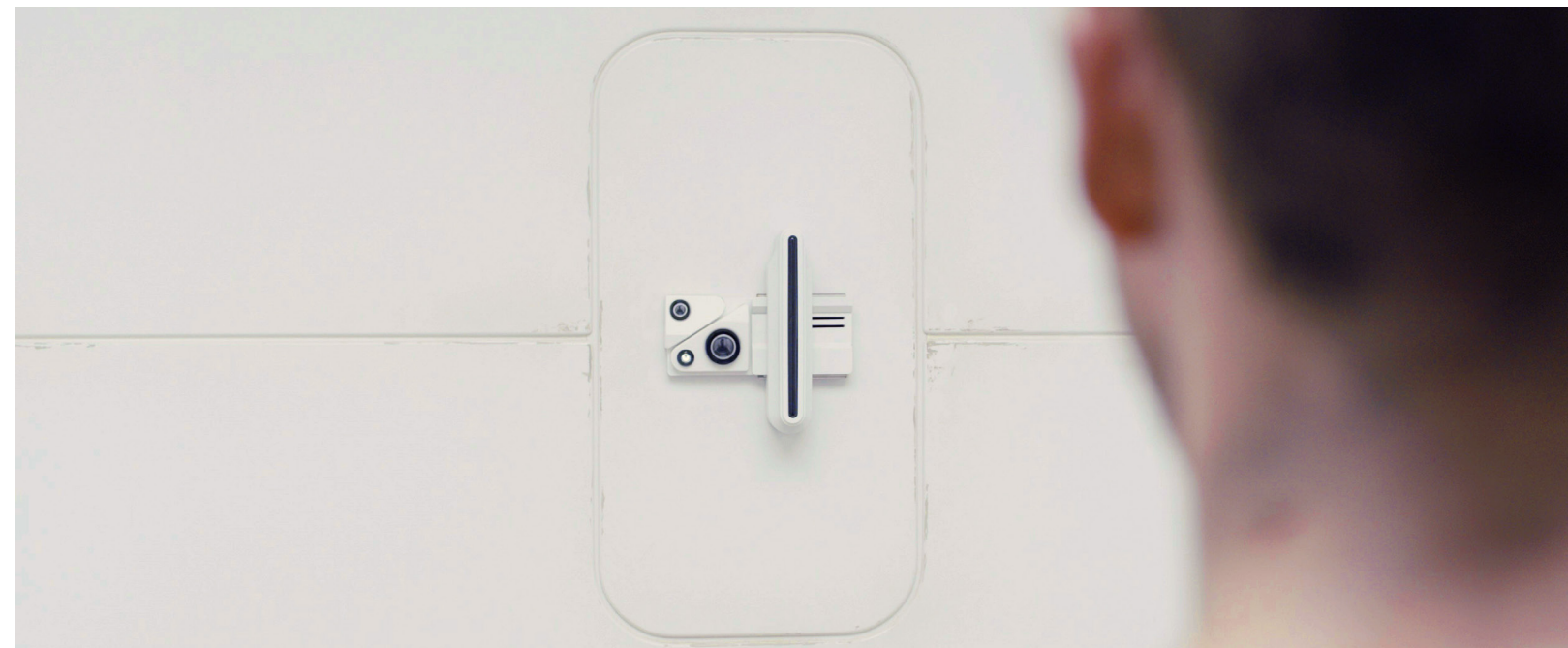

23
K's (Ryan Gosling) Charcoal Sweater

Officer K's (Ryan Gosling) charcoal sweater from BLADE RUNNER 2049. Officer K worked for the Los Angeles Police Department (LAPD) as a "blade runner," an officer who decommissioned rogue replicants-bioengineered humanoid servants that broke free of their human masters-and retired them. K wore his charcoal color sweater in the opening scenes during his fight with Sapper Morton (Dave Bautista) through the time that he returned to his apartment after the fight.

Included is one charcoal color knit sweater. It exhibits a production-added rip on the right arm and a mended tear on the lower left torso but remains overall in good condition.

Starting Bid: \$1,000

24
K's (Ryan Gosling) Screen-Matched
Blaster Shoulder Holster

Officer K's (Ryan Gosling) LAPD blaster shoulder holster from BLADE RUNNER 2049. Blade runners, including Officer K, worked for the Los Angeles Police Department (LAPD) to decommission rogue replicants-bioengineered humanoid servants that broke free of their human masters-and retire them. Police officials employed sturdy blaster holsters to store blasters when they were not in use. This lot screen-matches the scene where K was looking at the denabase machine via a unique pair of off-white dots on the strap fabric, unique stitching on the upper shoulder's stitch seam, and wear at the center of the button.

This lot includes one black, mixed material blaster shoulder holster with suspender clips and a production tag labeled "Hero Holster." The holster was tagged by production as "hero holster"; it is missing the lock-in spring strap and has been modified with gaffer's tape to hold a prop blaster on set. It remains in overall good condition.

Starting Bid: \$2,000





25
K's (Ryan Gosling) Micro Medical Kit

Officer K's (Ryan Gosling) micro medical kit from BLADE RUNNER 2049. Officer K worked for the Los Angeles Police Department (LAPD) as a "blade runner," an officer who decommissioned rogue replicants-bioengineered humanoid servants that broke free of their human masters-and retired them. K kept a medical kit in case of emergencies at home and in the field. The kit was visible after the opening fight scene where Sapper Morton (Dave Bautista) stabbed K in the arm; K returned to his apartment and found the kit in the bathroom where he used a first-aid ampoule's contents to fix his wound. The kit was seen at the bottom of the shot.

This lot includes one white metal medical kit and four sets of five single-use first aid applications in plastic ampoules. The cover features black text in English that reads "Micro Med Individual Medical Kit" and "Wallace Corporation" as well as numerical information in English and other foreign languages. The lid features an internal rubber seal and the container is fitted with foil padding to protect the single-use applications.

According to production wrap documents, only one micro medical kit prop of this style was created for the film.

The container exhibits scuff marks to the lid edges where the clamps close up and over, but the lot remains overall in very good condition.

Starting Bid: \$250

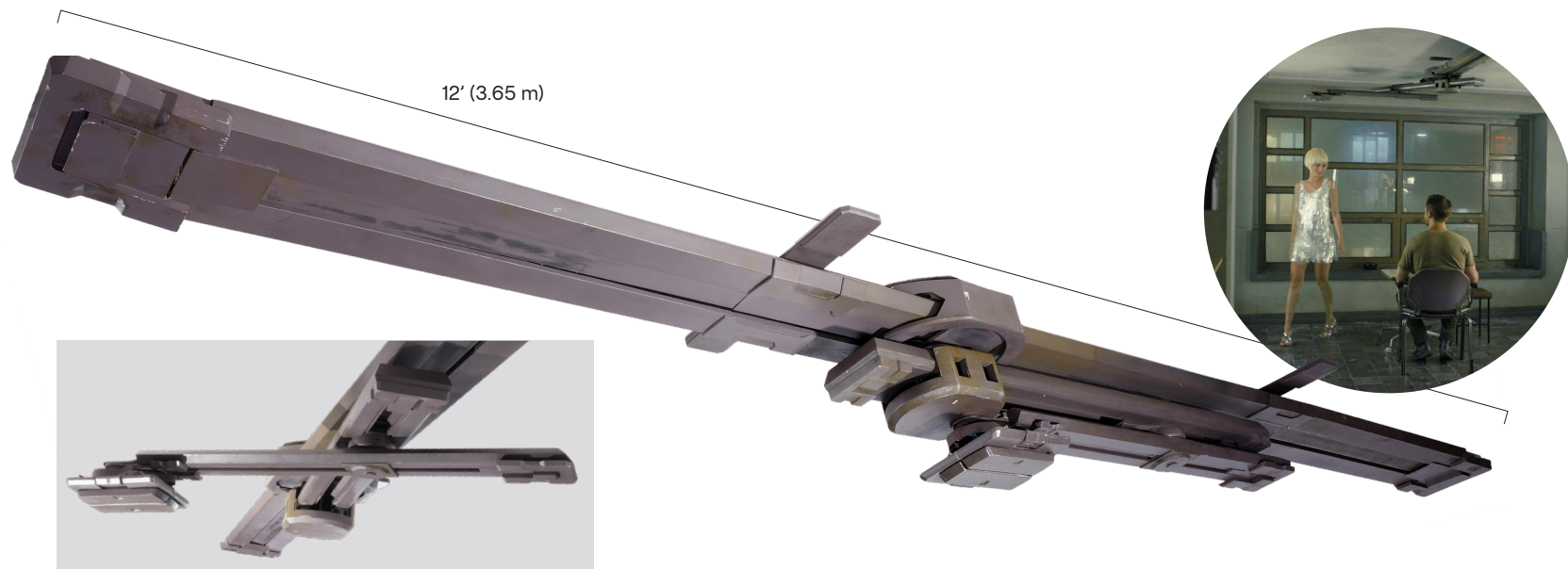

28
Ceiling-mounted SFX Joi (Ana de Armas) Projection Unit from K's (Ryan Gosling) Apartment

A ceiling-mounted special effects Joi (Ana de Armas) projection unit from K's (Ryan Gosling) apartment from BLADE RUNNER 2049. Joi was an artificial intelligence (AI) hologram that people-including Officer K-could purchase as a live-in romantic partner. The mechanical projection unit projected Joi's image throughout K's apartment but only within its physical walls. K later obtained an emanator which allowed Joi to exist outside the confines of the apartment projection unit.

This lot includes one ceiling mounted device with a rotating mechanical projection arm from Officer K's apartment. His AI hologram partner, Joi, appeared to be a solid figure, but was actually light projected from the unit; a non-solid figure that people could pass through without resistance. This complex piece was custom-built by the special effects department and features a steel beam base with plastic and resin cosmetic covering plates. Inside, it houses various motors, servos, and drive belts to enable the arm to move as seen in the film. Various cabling remains present, but no control device or power sources are included, so the electronics remain untested.

The projector head of the unit visible in the final film was modified through VFX; it was modified to look like a square plate with a round circular lens in the center. This is the on-set prop and was filmed as-is before being modified by the VFX team and its projector head is a pair of retractable doors that open to reveal a square LED light panel. Production and behind-the-scenes photos show this unit, with the square projector head with retractable doors, in use on set.

According to production wrap documents, only one ceiling-mounted projection unit prop from K's apartment was created for the film.

The lot exhibits nicking and scuffs to the finish but remains overall in good condition, with untested electronics.

Contains electronics; see electronics notice in the Buyer's Guide. Special shipping required; see special shipping notice in the Buyer's Guide. Contains mechanical components; see mechanical notice in the Buyer's Guide.

Starting Bid: \$1,000



29
K's (Ryan Gosling) Apartment Wall Videophone

Officer K's (Ryan Gosling) apartment wall video phone from BLADE RUNNER 2049. Officer K worked for the Los Angeles Police Department (LAPD) as a "blade runner," an officer who decommissioned rogue replicants-bioengineered humanoid servants that broke free of their human masters-and retired them. A videophone was on the wall of K's apartment and visible in several scenes, including when Mariette (Mackenzie Davis) joined Joi (Ana de Armas) and K for the evening in his apartment, and when Joi spoke to K in the kitchen.

This lot includes one mixed material wall videophone with a touchpad with silicon buttons and a lightbar at its bottom and a small camera lens as well as a concave rectangular space where the video screen component (not included) would have rested.

According to production wrap documents, only one apartment wall videophone prop was created for the film.

The lot exhibits scratches to its finish, paint chipping, and gouges from installation/removal, but remains overall in fair condition.

Starting Bid: \$1,000



Emanator shown in open and closed positions



30
K's (Ryan Gosling) Light-up Extendable Emanator with Black "JOI" Case, Orange Outer Box and Bubble Shipping Packaging

Officer K's (Ryan Gosling) LAPD light-up extendable emanator with black "JOI" case, orange outer box and bubble shipping packaging from BLADE RUNNER 2049. Blade runners, including Officer K, worked for the Los Angeles Police Department (LAPD) to decommission rogue replicants-bioengineered humanoid servants that broke free of their human masters-and retire them. Emanators were used to "free" Joi (Ana de Armas) from the bounds of Officer K's apartment so she could travel outside its borders and interact with humans. K carried his emanator with him throughout the film and it appeared in multiple scenes. The orange box, black case, and shipping bag were seen when he first gifted the emanator to Joi.

This lot includes one emanator, a "hero" version, features an extendable and collapsible black casing that with an illuminating circular ring light. Also included one black emanator case marked JOI, one semi-translucent orange box, and an opened transparent columnar bubble wrap package.

The lot exhibits slight creasing to the bubble wrap packaging, but remains overall in very good condition.

Contains electronic elements; please see notice in the Buyer's Guide.

Starting Bid: \$2,500





34
Joi's (Ana de Armas) Complete Housewife Costume

Joi's (Ana de Armas) complete housewife costume from BLADE RUNNER 2049. Joi was an artificial intelligence (AI) hologram that people—including Officer K (Ryan Gosling)—could purchase as a live-in romantic partner. Joi wore her costume when she presented a steak dinner to K in their apartment.

The costume's components are: • One yellow blouse with perforated flower patterns; • One gathered tulle petticoat; • One graphic print skirt with a gathered waistband; • One light orange apron with a gathered waistband; • One pair of multicolor wedge sandals; • One faux pearl necklace

According to production wrap documents, only one housewife costume was created for the film.

The lot remains overall in very good condition.

Starting Bid: \$1,500



37
Joi's (Ana de Armas) Loungewear Costume

Joi's (Ana de Armas) loungewear costume from BLADE RUNNER 2049. Joi was an artificial intelligence (AI) hologram that people—including Officer K (Ryan Gosling)—could purchase as a live-in romantic partner. Joi wore her complete loungewear costume inside K's apartment.

The costume's components are one black, long-sleeve, "cold-shoulder" cutout stretch blouse, one pair of black flare-leg pants, and one pair of black leather peekaboo wedge slingback shoes.

According to production wrap documents, only one loungewear costume was created for the film.

The lot remains overall in very good condition.

Starting Bid: \$1,000



38
Joi's (Ana de Armas) Silver-color Sequin Dress Costume

Joi's (Ana de Armas) complete silver-color sequin dress costume from BLADE RUNNER 2049. Joi was an artificial intelligence (AI) hologram that people—including Officer K (Ryan Gosling)—could purchase as a live-in romantic partner. Joi wore her complete silver-color sequin dress costume when she invited K to dance in their living room and the costume was seen briefly while Joi's wardrobe was changing in K's apartment.

The costume's components are one silver-color sequin A-line sleeveless dress, one pair of wrap-around sandals with a chrome-color finish, and one light blonde, chin-length wig with bangs.

According to production wrap documents, only one silver-color sequin dress costume was created for the film.

The lot remains overall in very good condition.

Starting Bid: \$1,500



39
Joi's (Ana de Armas) Screen-Matched Blue and White Dress

Joi's (Ana de Armas) screen-matched blue and white dress from BLADE RUNNER 2049. Joi was an artificial intelligence (AI) hologram that people—including Officer K (Ryan Gosling)—could purchase as a live-in romantic partner. All of the dresses for the film were hand-printed and hand-made, so the pattern placement—and especially the collar lines—vary from dress to dress. The collar pattern on this dress screen-matches the one worn onscreen in the apartment as well as in the rainy rooftop sequence.

The costume features a blue and white sleeveless A-line dress with a jewel neckline.

The lot remains overall in very good condition.

Starting Bid: \$2,500



40
K's (Ryan Gosling) Drinking Glass

Officer K's (Ryan Gosling) drinking glass from BLADE RUNNER 2049. Blade runners—including Officer K—worked for the Los Angeles Police Department (LAPD) to decommission rogue replicants—bioengineered humanoid servants that broke free of their human masters—and retire them. K smoked and drank as stress relievers and poured himself a drink in a glass after returning home from the Sapper fight as well as the scene where he met with Lt. Joshi (Robin Wright) in his apartment and she pressed him to recall childhood memories.

This lot includes one clear drinking glass cut with multiple faceted diamond-shaped cuts on a hexagonal base.

According to production wrap documents, this is one of six drinking glass props that were created for the film.

It remains overall in very good condition.

Starting Bid: \$500



41
K's (Ryan Gosling) Set of Decorative Apartment Tiles

Officer K's (Ryan Gosling) set of decorative apartment tiles from BLADE RUNNER 2049. Blade runners, including Officer K, worked for the Los Angeles Police Department (LAPD) to decommission rogue replicants—bioengineered humanoid servants that broke free of their human masters—and retire them. K's apartment was sparse but stylish in a brutalistic manner, and these tiles were visible in its kitchen.

This lot features 12 decorative tiles in various shades of gray with identical geometric designs carved into them. The tiles are made from a cast material and were likely made specifically for the film. They are a nod to the geometric "Ennis tiles" seen in the original Blade Runner film.

The tiles exhibit chips, nicking, and scratches but remain overall in good condition.

Starting Bid: \$500

Highlights catalog shows select Lots only -- See online catalog for all 200 Lots

42
K's (Ryan Gosling) Screen-Matched "Pale Fire" Book

Officer K's (Ryan Gosling) screen-matched "Pale Fire" book from BLADE RUNNER 2049. Officer K worked for the Los Angeles Police Department (LAPD) as a "blade runner," an officer who decommissioned rogue replicants—bioengineered humanoid servants that broke free of their human masters—and retired them. K read as a stress reducing tactic. The book appeared on a small table in K's apartment next to his cigarette box, alcohol, and glasses. Joi (Ana de Armas) picked up the book and asked K to read to her. The book screen matches based on folds and marks on the cover.

This lot includes one book, "Pale Fire" by Vladimir Nabokov and is a real book that has had a vinyl wrap protective cover applied.

The book exhibits creasing and minor dirt stains but remains overall in good condition.

Starting Bid: \$250

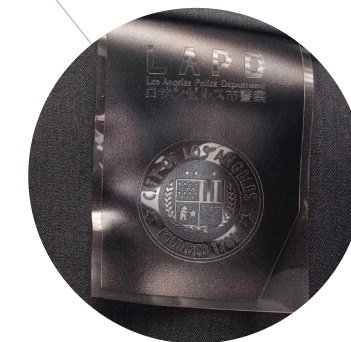

43
Lt. Joshi's (Robin Wright) LAPD Uniform Costume

Lt. Joshi's (Robin Wright) LAPD complete uniform costume from BLADE RUNNER 2049. Lt. Joshi was a member of the Retirement Division of the LAPD and Officer K's (Ryan Gosling) superior. Joshi wore her complete uniform in scenes in her LAPD office.

The costume's components are black slim-leg dress pants, a gray, tunic-length, zip-up sleeveless A-line fabric top, a gray, collarless, tunic-length, fabric A-line dress coat with long sleeves and flared cuffs with a rectangular plastic shoulder patch that reads "LAPD Los Angeles Police Department," with foreign lettering beneath and an image of the seal of the city of Los Angeles, and thick-heeled black suede boots.

According to production wrap documents, only one LAPD uniform costume was created for the film.

The pants exhibit some lightening of the fabric along the outer leg and hem, but the lot remains overall in very good condition.

Starting Bid: \$2,500



44
Sapper Morton's (Dave Bautista) Screen-Matched Footlocker for Rachel's (Sean Young) Remains

Replicant and combat medic Sapper Morton's (Dave Bautista) screen-matched footlocker for Rachel's (Sean Young) remains from BLADE RUNNER 2049. Replicants were bioengineered humanoid servants that answered to the directions and orders of their human masters in taking on unsavory or dangerous tasks so humans didn't have to. Rachael was a highly advanced prototype replicant designed as a test runner who could become pregnant, and was the mother of Ana Stelline (Carla Juri), a child conceived with Rick Deckard (Harrison Ford), a blade runner. She died during an emergency C-section performed by Morton, and her remains were later discovered by Officer K (Ryan Gosling) inside Morton's buried footlocker. The footlocker screen-matches to the shots in the morgue scene via its paintwork.

This lot includes one gray plastic foot locker in gray plastic with multicolor graphics spray painted on its exterior. It features external locking mechanisms, handles, and an attached plastic LAPD evidence tag.

According to production wrap documents, this is one of two footlocker props created for the film.

The lot exhibits scuffing, faded paint, scratches, nicks, and fading but remains overall in good condition.

Starting Bid: \$1,000

45
Rachael's (Sean Young) Skeleton Pieces

Replicants were bioengineered humanoid servants that answered to the directions and orders of their human masters in taking on unsavory or dangerous tasks so humans didn't have to in BLADE RUNNER 2049. Rachael (Sean Young) was a highly advanced prototype replicant who could become pregnant, and was the mother of Ana Stelline (Carla Juri), a child conceived with Rick Deckard (Harrison Ford), a blade runner. She died during an emergency C-section performed by Morton, and her remains were later discovered by Officer K (Ryan Gosling). The skeletal remains were seen in the morgue and lab scenes.

This lot includes 27 teeth and 75 bone pieces, including rib bones, femurs, sacrum, a jaw bone, and digital phalanges, among others.

The lot exhibits wear consistent with that of bones exposed to dirt and the elements, but remains overall in very good condition.

Starting Bid: \$1,000



49
K's (Ryan Gosling) File Clerk Note

Officer K's (Ryan Gosling) file clerk note from BLADE RUNNER 2049. Blade runners, including Officer K, worked for the Los Angeles Police Department (LAPD) to decommission rogue replicants-bioengineered humanoid servants that broke free of their human masters-and retire them. K gave the note to the clerk at the desk when he visited Wallace Corporation's memory vault with the sample of Rachael's (Sean Young) hair.

This lot includes one rectangular file clerk note that features black and red printed fields for information. The note comes with a transparent zip-top plastic bag that has black labels reading "K," "Hero," and "SC. 27" adhered to it.

According to production wrap documents, this is one of three file clerk note props that was created for the film.

The lot exhibits creasing but remains overall in very good condition.

Starting Bid: \$250

Highlights catalog shows select Lots only -- See online catalog for all 200 Lots

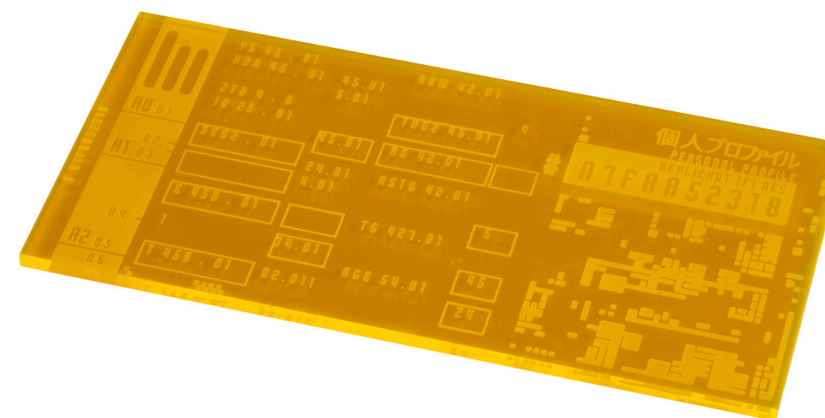

50
Memory Vault Plexi Key Data Card on Rachael

In BLADE RUNNER 2049, Niander Wallace (Jared Leto) was the visually impaired scientist, replicant manufacturer, technologist, and CEO of Wallace Corporation, a replicant manufacturing company. The company's replicants were indistinguishable from their human counterparts and were meant to take on unsavory or unsafe jobs that humans could not or did not want to take on. Replicant data was kept on plexiglass data cards maintained by the Archivist (Tomas Lemarquis) at the Wallace Corporation archives. The Archivist pulled the card in the memory vault at K's request.

This lot includes one rectangular plexiglass data key with a rounded upper right corner and created in transparent and opaque school-bus yellow shades that features the replicant's birth date, age, and other identifying data in English and other foreign languages.

According to production wrap documents, only one memory vault plexi key data card prop was created for the film.

The lot exhibits minor nicks and scratches but remains overall in good condition.

Starting Bid: \$250



52
Set of Five Prototype Memory Spheres

In BLADE RUNNER 2049, Niander Wallace (Jared Leto) was the visually impaired scientist, replicant manufacturer, technologist, and CEO of Wallace Corporation, a replicant manufacturing company. Replicants were indistinguishable from their human counterparts and were meant to take on unsavory or unsafe jobs that humans could not or did not want to take on. Memory spheres-and the memories stored on them-created a cushion for their emotions, which allowed for better control over them. The spheres were seen in the Wallace vault and archives.

This lot of five prototype memory spheres includes one clear glass memory sphere with four resin memory spheres. The resin spheres have been cast with feathery white swirl patterns inside.

The lot remains overall in very good condition.

Starting Bid: \$250



51
K's (Ryan Gosling) Evidence Bag with a Lock of Rachel's (Sean Young) Hair

Officer K's (Ryan Gosling) LAPD evidence bag with a lock of Rachael's (Sean Young) hair from BLADE RUNNER 2049. Officer K worked for the Los Angeles Police Department (LAPD) as a "blade runner," an officer who decommissioned rogue replicants-bioengineered humanoid servants that broke free of their human masters-and retired them. Rachael was a highly advanced prototype replicant who could become pregnant, and was the mother of Ana Stelline (Carla Juri), a child conceived with Rick Deckard (Harrison Ford), a blade runner. She died during an emergency C-section, and her remains were later discovered by Officer K. This lot was used in the same scene with the Archivist (Tomas Lemarquis) at Wallace Corporation when K handed it to him as identifying information as to who he was researching.

This lot contains one evidence bag with a lock of curly dark brown hair held in place in two spots by twine. The transparent LAPD evidence bag features a zip-top closure and white lettering in English and in a foreign language describing fields to detail the bag's contents.

According to production wrap documents, only one evidence bag with a lock of Rachael's hair prop was created for the film.

The evidence bag exhibits creasing but the lot remains overall in very good condition.

Starting Bid: \$500



53
K's (Ryan Gosling) Costume with Coat Matched
to Wallace Memory Vault Scene

Officer K's (Ryan Gosling) costume with his signature coat matched to the Wallace's memory vault scene, amongst others, from BLADE RUNNER 2049. Officer K worked for the Los Angeles Police Department (LAPD) as a "blade runner," an officer who decommissioned rogue replicants—bioengineered humanoid servants that broke free of their human masters—and retired them. The coat in this lot screen-matches to multiple scenes including K's visit to Wallace's memory vault; in K's apartment building hallways after his fight with Sapper Morton; when K met with Gaff (Edward James Olmos); in K's apartment before the love scene with Mariette (Mackenzie Davis) and Joi (Ana de Armas); in the Las Vegas casino interior when he first encountered Deckard, and outside the building where he met memory designer Dr. Ana Stelline (Carla Juri). The boots match to Luv (Sylvia Hoek) and the memory vault scene. The sweater screen-matches to the scene where K did his baseline test after meeting with Dr. Stelline based on the decorative repair stitching on the left shoulder.

The costume's components are: • One shearling collared, black leather insulated coat marked "K" and "Ryan Gosling"; • One black sweater with decorative repair stitching; • One long-sleeve undershirt marked "K" at the interior bottom; • One pair of khaki color pants marked "K1"; • One pair of brown leather gloves (Size 8.5) with a knitted yarn liner and decorative repair stitching; • One pair of unmarked black leather and rubber boots.

The coat's collar was taped into position (most of the coats used in the film had the collar stitched or taped down to hold their shape), however the tape is loose and the collar can also be displayed in the upright position, though the tape is visible. The boots exhibit nicks and scuffs, the pants exhibit fading and small tears, and all items show minor scuffing and some wear, but the lot remains overall in good condition.

Starting Bid: \$10,000

Highlights catalog shows select Lots only -- See online catalog for all 200 Lots



54
Luv's (Sylvia Hoeks) White Jacket Costume

Luv's (Sylvia Hoeks) complete white jacket costume from BLADE RUNNER 2049. Luv, a Nexus-9 model replicant who was initially gifted to the LAPD by Niander Wallace to serve as a blade runner and set the standard for Nexus-9 performance, eventually became Wallace's personal assistant. Luv wore her complete costume at Wallace Corporation when she was first introduced and when she met K (Ryan Gosling).

The costume's components are one winter white jacket, one taupe pencil skirt, one pair of peep-toe ankle boots in winter white leather, and one winter white leather belt with silver-color hardware.

The belt exhibits some residue, but the lot remains overall in very good condition.

Starting Bid: \$1,500

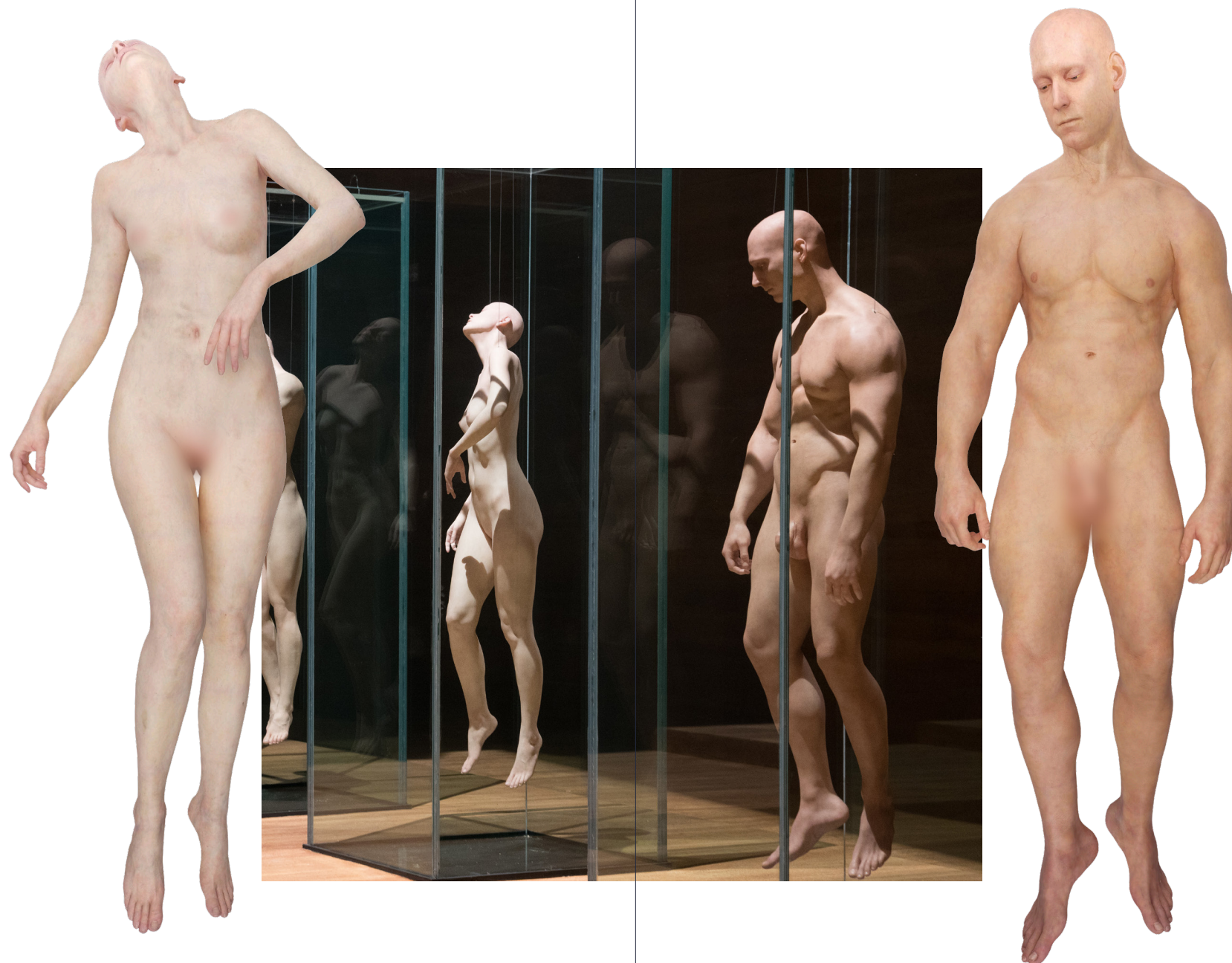

58
Female Nexus Replicant "Blank" Nexus 08 Body from Nexus Reliquary

In BLADE RUNNER 2049, Niander Wallace (Jared Leto) was the visually impaired scientist, replicant manufacturer, technologist, and CEO of Wallace Corporation, a replicant manufacturing company. The company's replicants were indistinguishable from their human counterparts and were meant to take on unsavory or unsafe jobs that humans could not or did not want to take on. Replicant "blank" Nexus 08 bodies were kept in storage at Wallace Corporation until they were ready to release.

This lot features a life-size female Nexus replicant blank Nexus 08 body from Nexus Reliquary. The figure is anatomically correct to the female form but is configured without any body hair. It features steel cables and hardware at the shoulders and crown for hoisting it into its vertical position within a clear display case (not included). It is constructed from dense, rigid material and is a heavy piece. The body was suspended from cables for filming but VFX removed the cables and made the body appear to float, with some motion, within the display case.

According to production wrap documents, only one female nexus replicant of this specific body type from nexus reliquary prop was created for the film. There are other female "character" bodies as well. It is constructed from dense, rigid material and is a heavy piece.

It remains overall in very good condition.

Starting Bid: \$1,000

59
Male Nexus Replicant "Blank" Nexus 08 Body from Nexus Reliquary

In BLADE RUNNER 2049, Niander Wallace (Jared Leto) was the visually impaired scientist, replicant manufacturer, technologist, and CEO of Wallace Corporation, a replicant manufacturing company. The company's replicants were indistinguishable from their human counterparts and were meant to take on unsavory or unsafe jobs that humans could not or did not want to take on. Replicant "blank" Nexus 08 bodies were kept in storage at Wallace Corporation until they were ready to release.

This lot features a life-size male Nexus replicant blank Nexus 08 body from Nexus Reliquary. The figure is anatomically correct to the male form but is configured without any body hair. It features steel cables and hardware at the shoulders and crown for hoisting it into its vertical position within a clear display case (not included). It is constructed from dense, rigid material and is a heavy piece. The body was suspended from cables for filming but VFX removed the cables and made the body appear to float, with some motion, within the display case.

According to production wrap documents, only one male nexus replicant of this specific body from nexus reliquary prop was created for the film. There are other male "character" bodies as well.

It remains overall in very good condition.

Starting Bid: \$1,000

60
Gaff's (Edward James Olmos) Motorized Wheelchair

In the original Blade Runner, Gaff (Edward James Olmos) was an LAPD police officer who escorted blade runner Rick Deckard (Harrison Ford) during his assignment to retire renegade replicants. In BLADE RUNNER 2049, Officer K (Ryan Gosling) discovered Gaff in a nursing home. Gaff was a recurring character from the original film. Gaff's wheelchair sat behind him in the nursing home where he resided as K asked about his history with Deckard, as well Deckard's current whereabouts.

The motorized wheelchair features a padded seat and headrest and is powered by two 12V vehicle batteries.

According to production wrap documents, only one of Gaff's wheelchair props was created for the film.

Contains electronics; see electronics notice in the Buyer's Guide.

Special shipping required; see special shipping notice in the Buyer's Guide.

Contains mechanical components; see mechanical notice in the Buyer's Guide.

The lot has been intentionally distressed to look well-used and the motor remains untested. It exhibits scuffing on the metal support for the leg and arm rest, scuffs, grime, and dirt buildup on the frame and tires, and a missing seat cushion; it remains overall in fair condition.

This lot is currently located in Propstore's London facility and will ship directly to the Buyer from the London facility. Buyer will be responsible for all shipping and import charges from the UK. Please inquire for additional information.

Starting Bid: \$500



49.2" (125 cm)



61
Gaff's (Edward James Olmos) Costume

In the original Blade Runner, Gaff (Edward James Olmos) was an LAPD police officer who escorted blade runner Rick Deckard (Harrison Ford) during his assignment to retire renegade replicants. In BLADE RUNNER 2049, Officer K (Ryan Gosling) discovered Gaff wheelchair bound in a nursing home and questioned him about Deckard's whereabouts. Gaff was a recurring character from the original film. He and the other nursing home patients wore standard issue clothing during scenes in the nursing facility.

The costume's components are: • One white button-down, short sleeve shirt with an ID armband; • One white long-sleeve pullover shirt; • One pair of white pants with slip pockets; • One pair of white elastic suspenders with silver-color clasps; • One pair of white slip-on tennis shoes.

According to production wrap documents, only one Gaff costume was created for the film.

The shoes exhibit dark scuffs, and the long-sleeve pullover shirt exhibits staining on the right arm and tag, but the lot remains overall in good condition.

Starting Bid: \$500



63
Gaff's (Edward James Olmos) Sheep Origami

In the original Blade Runner, Gaff (Edward James Olmos) was an LAPD police officer who escorted blade runner Rick Deckard (Harrison Ford) during his assignment to retire renegade replicants. In BLADE RUNNER 2049, Officer K (Ryan Gosling) discovered Gaff wheelchair bound in a nursing home and questioned him about Deckard's whereabouts. Gaff was a recurring character from the original film. Gaff historically crafted origami figures that served as symbolic metaphors and presented Officer K with a white sheep at the nursing home. The gesture is a callback to the novel by Peter K. Dick titled Do Androids Dream of Electric Sheep? that the Blade Runner franchise is based on as well as the original Blade Runner film.

This lot includes one sheep origami crafted from thick, white paper.

According to production wrap documents, only one of Gaff's sheep origami props was created for the film.

It exhibits some fraying and tearing at stress points, including the top middle back of the sheep and the left side of its face, but remains overall in good condition.

Starting Bid: \$250



64
Niander Wallace (Jared Leto) Screen-Matched Primary Small Halo Cube with Neck LED

Niander Wallace's (Jared Leto) primary small halo cube with neck LED from BLADE RUNNER 2049. Industrialist Niander Wallace was the visually impaired head of the corporation that made replicants. Halos controlled the small drones that enabled Wallace to "see." This lot screen-matches to the scene where Wallace "plugged in" to "see" the newborn replicant via the floating barracuda devices. The halo cube is a small chip and has a separate magnetic baseplate that has make-up glue residue from where it was glued to the actor's nape. The LED was also applied to the neck via make-up, with the cable hidden and battery pack out of camera.

This lot includes one small halo cube and one light-up neck LED, that features three power cords that eventually end at a small magnetic base that the light-up neck LED snaps onto. The white plastic and electronic LED features a plug receptacle and writing and numbers in black text in English and in a foreign calligraphic character.

According to production wrap documents, only one of Wallace's primary small halo cube with this specific graphic was created for the film.

The lot exhibits some tape residue on the cording but the lot remains overall in very good condition.

Contains electronic elements; please see notice in the Buyer's Guide.

Starting Bid: \$500

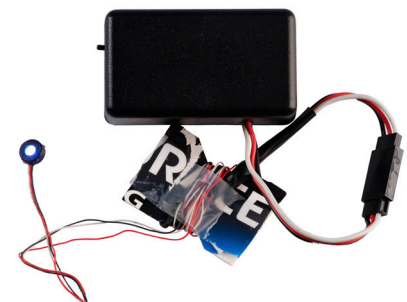

67
Niander Wallace's (Jared Leto) Black Gi

Niander Wallace's (Jared Leto) black gi from BLADE RUNNER 2049. Industrialist Niander Wallace was the visually impaired head of the corporation that made replicants. Wallace wore his black gi when he was first introduced in the film and reviewed, and then killed, a replicant unable to reproduce.

The costume's components are one black gi jacket with a kimono collar, one pair of black gi pants, and one pair of black leather sandals.

According to production wrap documents, only one of Wallace's black gi costumes was created for the film.

The lot remains overall in very good condition.

Starting Bid: \$500

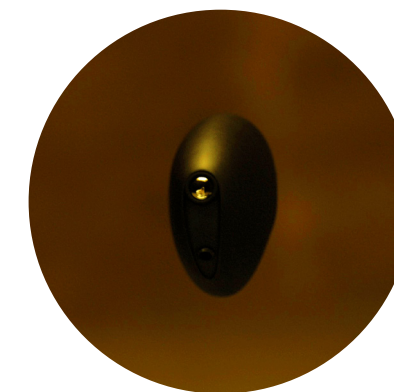

68
Niander Wallace (Jared Leto) Light-Up Barracuda Device

Niander Wallace's (Jared Leto) light-up barracuda device from BLADE RUNNER 2049. Industrialist Niander Wallace was the visually impaired head of the corporation that made replicants. The barracuda device connected to a special halo cube on Wallace's neck to enable him to "see." The devices were seen in early scenes of the film when a new replicant was "born" in front of Wallace and Luv (Sylvia Hoek) at Wallace headquarters.

This lot includes one light-up barracuda device crafted of mixed materials in a dark silver-color finish in a shape that resembles an elongated teardrop. The device is powered via a flat circular battery within that is revealed when the magnetically-secured cover is removed. The barracuda has a threaded mount on the bottom that allows it to mount onto a support post to be positioned on set. A practical, blue-colored LED light is activated by a hidden switch under the body cover.

The item remains overall in very good condition.

Contains electronic elements; please see notice in the Buyer's Guide.

Starting Bid: \$1,000



69
Niander Wallace (Jared Leto) Screen-Matched Halo Slide Box with Halo Cubes

Niander Wallace's (Jared Leto) halo slide box with halo cubes from BLADE RUNNER 2049. Industrialist Niander Wallace was the visually impaired head of the corporation that made replicants. Halos controlled the small drones that enabled Wallace to "see." This lot screen-matches to the scene where Wallace attached the Halo cube to his neck to "see" via the floating Barracuda devices; the match is clear through the unique wood grain on the storage box.

This lot includes one halo slide box with six halo cubes. The slide box features a light color wood finish and is an elongated triangle where the triangular top covers a mixed material internal core that individually houses up to nine dice; the lot comes with six multicolored dice.

According to production wrap documents, only one hero Wallace halo slide boxes with opening lid and halo cubes props was created for the film.

It remains overall in very good condition.

Starting Bid: \$1,000



70
Sapper Morton's (Dave Bautista) Screen-Matched Cigarette Tin with Old Baby Sock and Proxy Photos and VFX Photo

Replicant and combat medic Sapper Morton's (Dave Bautista) screen-matched cigarette tin, baby sock, proxy photos, and VFX photo from BLADE RUNNER 2049. Blade runners, including Officer K (Ryan Gosling) worked for the Los Angeles Police Department (LAPD) to decommission rogue replicants-bioengineered humanoid servants that broke free of their human masters-and retire them. K found photos in Morton's apartment that provided clues about Rachael's (Sean Young) death and the birth of her human/replicant hybrid baby, and this lot screen-matches to that scene via the marks and distressing on the cover and inside of the tobacco tin, the stitching and unique tufts on the sock, and the writing and stain spotting on the back of the proxy photo.

This lot includes one metal tobacco tin, one baby sock, two color photos, and one green VFX photo. The photos are marked "6-10-21" on the back and one matches to the photo placed in the tin on-screen. The metal tin is painted with multicolor logos and banners in English and in a foreign language and features a hinged cover. The knitted baby sock was once probably white or ivory; the two photos depict a young brunette woman posing holding a baby next to a large tree-the tree where Officer K (Ryan Gosling) later found Rachael's (Sean Young) bones buried beneath its roots. The printed photos featuring the actress are different to the final photos seen in the film; final photos likely created with VFX, thus the VFX cards. The green VFX photo features white placement crosses at the center and four corners and there are holes punched in the centers of two of the corner crosses. The intention is for the actor to perform with these on set and then the actual photographic image is dropped in later, which gives filmmakers flexibility in what to show.

According to production wrap documents, this was the only tin and sock created for the film.

The VFX photo exhibits a dark smudge near the center cross; the metal tin features paint wear, denting, and scuffing; the sock exhibits dirt buildup, tears, and snags; and the color photos exhibit staining, edge wear, fading, and grime buildup; the lot remains overall in production-distressed condition.

Starting Bid: \$1,000



71
Luv's (Sylvia Hoeks) White Dress

Luv's (Sylvia Hoeks) white dress from BLADE RUNNER 2049. Luv, a Nexus-9 model replicant who was initially gifted to the LAPD by Niander Wallace (Jared Leto) to serve as a blade runner and set the standard for Nexus-9 performance, eventually became Wallace's personal assistant. Luv wore her white dress at Wallace Corporation, specifically in the first scene with Wallace in his black gi costume as well as the scene where she received a manicure and simultaneously fired rockets at K's crashed spinner in the Trash Mesa scene.

The costume's components are one off-white dress with long sleeves, and one broad white belt with silver-color hardware and a zipper closure and a tag pinned to it that reads "stain on the side" referring to what appears to be the shadow remains of an ink stain in the shape of a boxy outline.

According to production wrap documents, this is one of two of Luv's white dress costumes created for the film.

The dress also exhibits a dark smudge near one of its frontal seams, but the lot remains overall in very good condition.

Starting Bid: \$1,500



73
Joi's (Ana de Armas) Blue Hologram Costume

Joi's (Ana de Armas) blue hologram costume from BLADE RUNNER 2049. Joi was an artificial intelligence (AI) hologram that people-including Officer K (Ryan Gosling)-could purchase as a live-in romantic partner. Joi wore her complete blue hologram costume in a hologram presentation at Bibi's Bar where she danced with a liquor bottle.

The costume's components are: • One chin-length wig; • Two padded blue foam and plastic knee pads marked "R" and "L"; • Six blue fabric laces; • One red bra marked "3"; • One pair of white underwear; • One blue transparent vinyl top; • One blue stretchy fabric bell top; • One short blue and red pleated "cheerleader" skirt; • One pair of white stockings; • One pair of white platform boots with a tag that reads "CH. 9 Boots 3. Joi."; • One pair of blue ombre leg warmers; • Six blue leg belts marked "Ankle Left," "Calf Left," "Knee Left," "Ankle Right," "Calf Right," and "Knee Right"; • One pair of blue lace arm warmers; • One blue patent leather belt; • One blue transparent vinyl belt; • One production bag labeled "HotShot #3 Joi Sc 51 pt/D4 CH#9 (1 of 2 Bag/Box) Ch. #9."

According to production wrap documents, only one blue hologram costume was created for the film.

The boots exhibit lights that do not work with new batteries and may need to be repaired, but the lot remains overall in very good condition.

Starting Bid: \$1,500



74
Freysa Sadeghpour's (Hiam Abbass) Costume

Freysa Sadeghpour's (Hiam Abbass) costume from BLADE RUNNER 2049. Sadeghpour was a Nexus-8 replicant combat engineer and the leader of a replicant freedom group and wore her complete costume when she met with K (Ryan Gosling) and informed him that Rachael (Sean Young) had a daughter.

The costume's components are one sleeveless dark gray velveteen dress, one long slub-texture hooded coat, and tall, black rubber low-heel boots.

According to production wrap documents, only one Freysa costume was created for the film.

The dress exhibits tearing and wear at the arm holes, while the coat exhibits a rip in the right armpit, but the lot remains overall in very good condition.

Starting Bid: \$500



81
K's (Ryan Gosling) Proxy Photo and VFX Photo

Officer K's (Ryan Gosling) proxy photo and VFX photo from BLADE RUNNER 2049. Blade runners, including Officer K, worked for the Los Angeles Police Department (LAPD) to decommission rogue replicants-bioengineered humanoid servants that broke free of their human masters-and retire them. K found photos in Morton's apartment that provided clues about Rachael's (Sean Young) death and the birth of her human/replicant hybrid baby.

This lot includes one color photo and one blue VFX photo. Both are marked with "6-10-21" in black ballpoint pen on the reverse. The color photo depicts a young brunette woman posing with a baby in her arms outside next to a large tree-the tree where Officer K (Ryan Gosling) later found Rachael's (Sean Young) bones buried beneath its roots. The printed photos featuring the actress are different to the final photos seen in the film; final photos likely created with VFX, thus the VFX cards. The blue VFX photo features white placement crosses at the four corners. The intention is for the actor to perform with these on set and then the actual photographic image is dropped in later, which gives filmmakers flexibility in what to show.

The color photo exhibits staining, rippling, edge wear, and grime buildup; the lot remains overall in production-distressed condition.

Starting Bid: \$1,000



85
Lt. Joshi's (Robin Wright) Metallic Costume

Lt. Joshi's (Robin Wright) metallic costume from BLADE RUNNER 2049. Lt. Joshi was a member of the Retirement Division of the LAPD and Officer K's (Ryan Gosling) superior. Joshi wore her metallic costume in K's apartment when she asked K if he had any memories from "before" and he shared one about the carved wooden horse toy he had as a child.

The costume's components are a fitted, black sleeveless dress; a long, sleeveless metallic coat; a zip-up metallic bolero jacket with long sleeves, and a production bag labeled "Hot Stock #6 Joshi Sc. #46-47-47b/N3 CH. #3."

According to production wrap documents, only one Joshi metallic costume was created for the film.

The lot remains overall in very good condition.

Starting Bid: \$1,500

87
Screen-Matched LAPD Denabase Machine

A screen-matched LAPD denabase machine from BLADE RUNNER 2049. Blade runners worked for the Los Angeles Police Department (LAPD), officers who hunted rogue replicants-bioengineered humanoid servants that broke free of their human masters-and retired them. Replicant data was stored in a massive DNA database machine that stored individual DNA cards and interested parties could view the cards containing that replicant data in a denabase machine. K (Ryan Gosling) and Joi (Ana de Armas) used the denabase machine to research children born on 6-10-21, the date carved into the carved wooden horse toy of his childhood. The lot screen-matches to aged surfaces around the left-hand "three ring knob" and at the bottom left corner of the frame during the scene where K searched for DNA information.

This lot includes one denabase machine comprised of metal, plastic, and other materials in shades of gray and black with antique pewter hardware and multicolor electrical cords emerging from the machine's right side. This is the main component of the denabase machine only and does not contain the oversized base.

According to production wrap documents, only one denabase machine prop was created for the film.

The machine's electronic components have been removed and it exhibits signs of distressing or around the three-ring knob as well as a buildup of grime and minor nicks and scratches to the finish, and the keypad beneath the viewfinder does not exhibit any labeled markings, but the lot remains overall in good condition.

Starting Bid: \$2,500



36"
(91.44 cm)

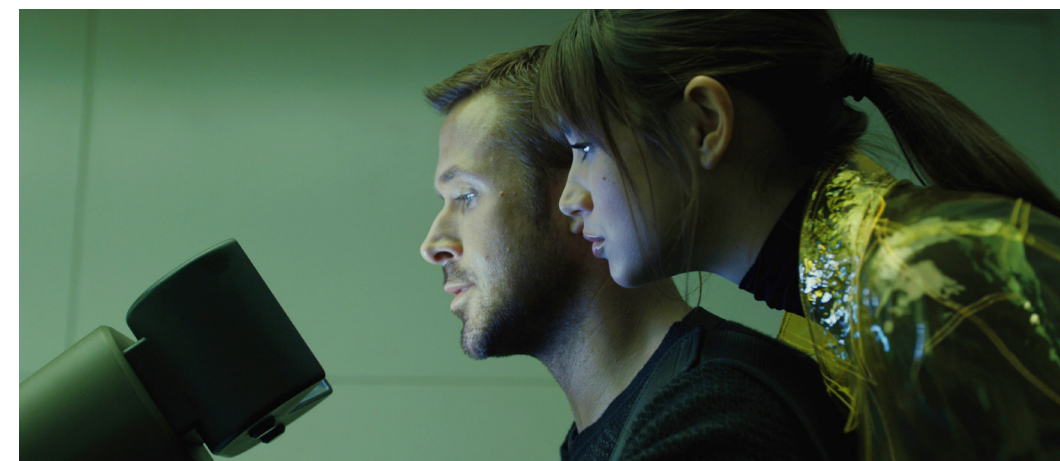

88
Joi's (Ana de Armas) Turtleneck and Clear Yellow Jacket Ensemble

Joi's (Ana de Armas) turtleneck and clear yellow jacket ensemble from BLADE RUNNER 2049. Joi was an artificial intelligence (AI) hologram that people-including Officer K (Ryan Gosling)-could purchase as a live-in romantic partner. Joi wore her complete ensemble in the denabase machine scene where she and K searched for DNA on a child born on 6-10-21 and when she and K flew to the trash mesa.

The costume's components are: • One transparent yellow plastic long-sleeve thigh-length jacket; • One black pullover turtleneck sweater; • One black textured pattern fabric miniskirt (marked "ACTION"); • One pair of black leather knee-high buckled boots with clear straps; • Two production tags: one reads "Joi," and the other, "Blade Runner 2049 6/6"

The turtleneck exhibits a hole on the back and some light smudges on the front; the yellow plastic jacket exhibits creasing throughout; and the miniskirt exhibits a white smudge at the waistline, but the lot remains overall in very good condition.

Starting Bid: \$5,000



89

K's (Ryan Gosling) Screen-Matched Hero LAPD 2049 Blaster

Officer K's (Ryan Gosling) screen-matched hero LAPD 2049 blaster from BLADE RUNNER 2049. Officer K worked for the Los Angeles Police Department (LAPD) as a "blade runner," an officer who decommissioned rogue replicants—bioengineered humanoid servants that broke free of their human masters—and retired them. One of the key props from the film and one of the most notable auction lots, the blaster was custom designed and built specifically for the production and is an update on the design of Deckard's blaster in the original film. This hero blaster screen-matches multiple scenes, including the Trash Mesa and sitting on table in Sapper Morton's (Dave Bautista) farmhouse, and also matches the promo photos used on the poster.

The prop features electronics, including a sliding recoil mechanism and practical red LED lights. The electronics are activated via a hidden depression switch on the left side of the gun, and are powered by a rechargeable battery housed in the grip.

This lot contains one blaster with two barrels composed of metal, plastic, and mixed materials in black and a black and grey checkerboard pattern on the ergonomic grip.

According to production wrap documents, this is one of three hero prop blasters that were created for the film.

The blaster exhibits chipping to the finish, scratches, and small nicks, but remains overall in good condition. There is also dirt from filming present in the detailing on the blaster's left side.

Contains electronic elements; please see notice in the Buyer's Guide.

Starting Bid: \$10,000



90
K's (Ryan Gosling) Closed Light-up Emanator

Officer K's (Ryan Gosling) LAPD closed light-up emanator from BLADE RUNNER 2049. Blade runners, including Officer K, worked for the Los Angeles Police Department (LAPD) to decommission rogue replicants-bioengineered humanoid servants that broke free of their human masters-and retire them. Emanators allowed replicant Joi (Ana de Armas) to physically materialize outside Officer K's apartment and interact with the outside world.

This lot includes one closed light-up emanator made from matte black plastic in a long squared off tube with beveled edges along their entire length. At one end, a round light ring lies embedded in the device and "joi" and a small numeric figure appear carved into the plastic.

According to production wrap documents, this is one of two closed light-up emanators that was created for the film.

It remains overall in very good condition.

Contains electronic elements; please see notice in the Buyer's Guide.

Starting Bid: \$1,000

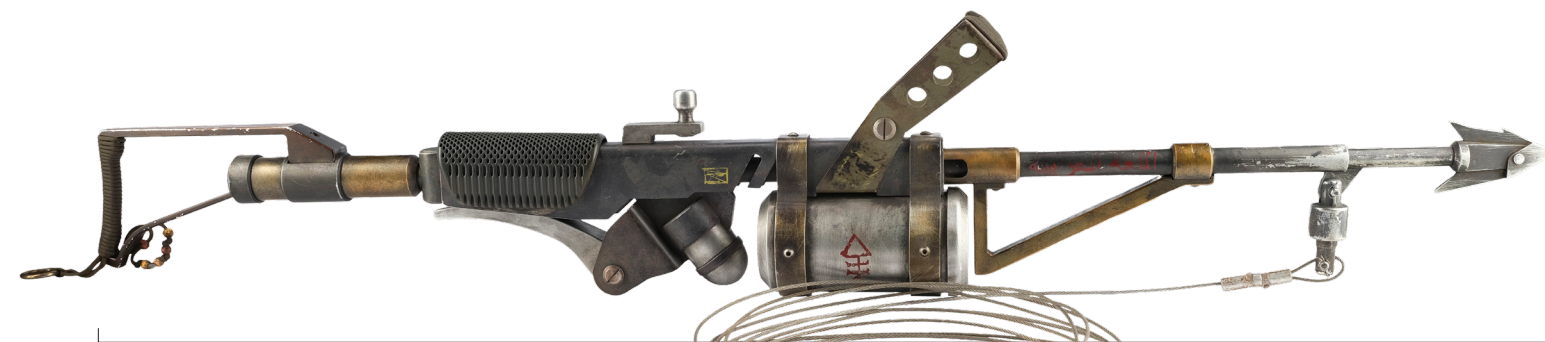

43" (109 cm)

91
Trash Mesa Inhabitant's Harpoon Gun
From K's Spinner Takedown

A Trash Mesa inhabitant's harpoon gun from K's (Ryan Gosling) spinner takedown from BLADE RUNNER 2049. Blade runners, including Officer K, worked for the Los Angeles Police Department (LAPD) to decommission rogue replicants-bioengineered humanoid servants that broke free of their human masters-and retire them. Scavengers used harpoon guns to grab discarded loot. The construction of this lot aligns to the one used to bring down K's spinner, but it is not dirtied and may have been cleaned after filming or unused/unseen in the film's final cut, or used by someone else in the scene.

This lot includes one black and silver-color metal harpoon gun and three metal harpoons, with one attached to a steel cable.

The lot exhibits wear to the finish, nicks, and scratches, but remains overall in good condition.

Starting Bid: \$1,000



96
Luv's (Sylvia Hoeks) VR Glasses

Luv's (Sylvia Hoeks) VR glasses from BLADE RUNNER 2049. Luv, a Nexus-9 model replicant who was initially gifted to the LAPD by Niander Wallace (Jared Leto) to serve as a blade runner and set the standard for Nexus-9 performance, eventually became Wallace's personal assistant. Luv wore her VR glasses while she received a manicure and simultaneously used the glasses to shoot down K's attackers.

This lot includes one pair of metal and plastic VR glasses. The silver-color metal frame fits around the wearer's head in a wraparound style. The smoke-color, rectangular plastic lenses are attached to the frame with tiny screws at the temples and wrap around the sides of the wearer's face before flattening out in front of the wearer's eyes.

The glasses are fragile and slightly bent/crooked in the lens area, but remain overall in good condition.

Starting Bid: \$1,000



97
Production-made K's (Ryan Gosling) Wooden Horse and Rag from Orphanage

Officer K's (Ryan Gosling) production-made wooden horse and rag from the orphanage from BLADE RUNNER 2049. Officer K worked for the Los Angeles Police Department (LAPD) as a "blade runner," an officer who decommissioned rogue replicants-bioengineered humanoid servants that broke free of their human masters-and retired them. K had only one toy as a child in the orphanage, a carved wooden horse that other boys beat him up to try and steal, but not before he wrapped it in a rag and hid it in the ashes of underground furnaces, only to find it years later.

This lot contains one small production-made carved wooden horse and one gray rag with fringed edges. The horse displays a brownish gray appearance and rough carving marks, and the gray rag features unraveled edges. This is not the hero horse but is a production-made example. It does not feature the date carved into the bottom as seen in the film; closeups of the date carved into the base may have been VFX shots.

The horse exhibits edgewear and the rag exhibits fading and thread unraveling, but the lot remains overall in good condition.

Starting Bid: \$2,500

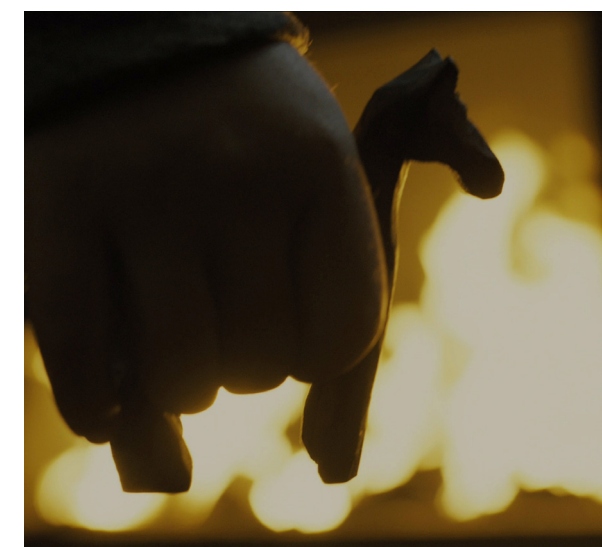



101 Mister Cotton's (Lennie James) Costume

Mister Cotton (Lennie James) was in charge of an orphanage and sweatshop that used child labor in BLADE RUNNER 2049. He worked from a cavernous, messy office within the orphanage facility that featured records, supplies, and a variety of artwork and trinkets and wore his complete outfit in the orphanage scenes with K (Ryan Gosling) where K searched for information about the child.

The costume's components are: • One tan overcoat; • One black suit jacket with a production tie attached; • One ivory color button-up shirt; • One light gray T-shirt; • One pair of brown dress pants; • One Reddish brown scarf; • One jewel-tone print necktie; • One pair of black leather gloves; • One pair of boots

The overcoat exhibits fraying, tearing, pilling, and wear throughout; the button-up shirt exhibits dirt and grime buildup; the dress pants exhibit fading and wear; the gloves exhibit color fade; and the boots exhibit pitting and flaking to the rubber and a buildup of dirt and grime; however, the lot remains overall in good condition.

Starting Bid: \$500



103 Dr. Ana Stelline's (Carla Juri) Costume

Dr. Ana Stelline's (Carla Juri) complete costume from BLADE RUNNER 2049. Rick Deckard (Harrison Ford) was the human father of a half human/half replicant child, Ana Stelline, a scientist who designed memories for replicants with the help of Officer K (Ryan Gosling), otherwise known as the Nexus-9 Replicant, KD6-3.7. Dr. Stelline wore her complete costume as she worked in an isolated, sterile lab inside Wallace Corporation.

The costume components are one oatmeal color sleeveless vest with a handkerchief edge; one white silky long-sleeve crew neck pullover shirt; one pair of silky off-white pants; and one pair of beige canvas loafers marked "7 Ana" on an inside tag.

The vest exhibits some slight brown spot staining but the lot remains overall in very good condition.

Starting Bid: \$500



105 Joi's (Ana de Armas) Billboard Ad Kimono and Wig

Joi's (Ana de Armas) Billboard ad kimono and wig from BLADE RUNNER 2049. Joi was an artificial intelligence (AI) hologram that people—including Officer K (Ryan Gosling)—could purchase as a live-in romantic partner. Joi wore various costumes to make billboard ads, and was seen wearing a kimono in a digital billboard ad as K flew through the city.

The costume's components are one multicolor blue kimono with a floral design and matching self-belt; one pink and purple obi belt; one pair of "geta" traditional Japanese sandals; and a production bag labeled "'Hotstock #3 Joi Sc: 80A/N5 CH #11."

According to production wrap documents, only one billboard ad kimono and wig costume was created for the film.

The geta exhibit chipping at the left toe and slight wear on the footbeds, but the lot remains overall in very good condition.

Starting Bid: \$1,000



106 Mariette's (Mackenzie Davis) Love Scene Costume and Wig

Mariette's (Mackenzie Davis) love scene costume and wig. Mariette was a Nexus-8 replicant who worked as a doxie, a skilled manipulator and sometimes even an assassin—who used human nature to achieve their goals. She was also a member of the replicant freedom group led by Freysa Sadeghpour (Hiam Abbass).

Mariette wore her complete costume and shag-cut, pinkish blonde wig in the apartment scene where Joi (Ana de Armas) employed her to sync up and help Joi become "physical" so she and K (Ryan Gosling) could be intimate.

The costume's components are: • One maroon waist-length fake fur coat with long sleeves; • One beige tank top; • One gray velveteen miniskirt; • One red and black bra; • One pair of black leather lug boots; • One strawberry blonde shag-cut wig; • One production bag labeled "Hot Stock #14 Mariette Sc. 75a;76-76a-76b-76c-76d,76e-76f-76g-81/N5 CH#2,2a,2b."

According to production wrap documents, only one love scene costume and wig was created for the film.

The tank top exhibits discoloration, but the lot remains overall in very good condition.

Starting Bid: \$500



107
K's (Ryan Gosling) Light-up
LAPD Wallet

Officer K's (Ryan Gosling) light-up LAPD wallet from BLADE RUNNER 2049. Officer K worked for the Los Angeles Police Department (LAPD) as a "blade runner," an officer who decommissioned rogue replicants-bioengineered humanoid servants that broke free of their human masters-and retired them. He carried a light-up LAPD wallet with identification and his badge and showed it to memory maker Dr. Ana Stelline (Carla Juri) when he met her.

This lot contains one black leather, light-up bifold wallet with two clear vinyl windows inside that display a blue and white LAPD identification card on one side and a silver-color LAPD badge on the other. The exterior of the wallet features a sewn-on clear vinyl label that runs the length and width of the wallet and reads "LAPD," "Los Angeles Police Department," and foreign lettering underneath all in a light silver-color print. Three flat round batteries power tiny lights attached to the back of the ID badge, which has an illuminating panel behind it that lights up when the wallet is opened.

According to production wrap documents, this is one of two prop K light-up wallets that were created for the film.

The wallet remains overall in very good condition.

Contains electronic elements; please see notice in the Buyer's Guide.

Starting Bid: \$5,000

108
K's (Ryan Gosling) Slide Reader with
Woman and Tree Slide

Officer K's (Ryan Gosling) LAPD slide reader with woman and tree slide from BLADE RUNNER 2049. Blade runners, including Officer K, worked for the Los Angeles Police Department (LAPD) to decommission rogue replicants-bioengineered humanoid servants that broke free of their human masters-and retire them. K's slide reader was custom designed and built for the film and was visible on a table in the background during several shots in K's apartment. While he used it to view slides in detail, it was seen in the background and was not prominently featured in the final film.

This black metal and mixed materials, battery operated, light-up slide reader comes with one silver-color brushed metal slide negative film of the tree outside Sapper Morton's (Dave Bautista) farm where K discovered Rachael's (Sean Young) remains. A woman and a baby are in front of the tree. The reader turns on, illuminates, and shows digital images.

This reader has an extendable side module that opens so the physical slide prop can be inserted. There is a switch that turns the screen on and it rotates through a variety of images on a timer that relate to story points such as the woman with the child, bones, etc. It also rotates through a greenscreen image for potential VFX use.

According to production wrap documents, this is one of three prop slide readers that were created for the film.

The reader remains overall in very good condition.

Contains electronic elements; please see notice in the Buyer's Guide.

Starting Bid: \$1,000

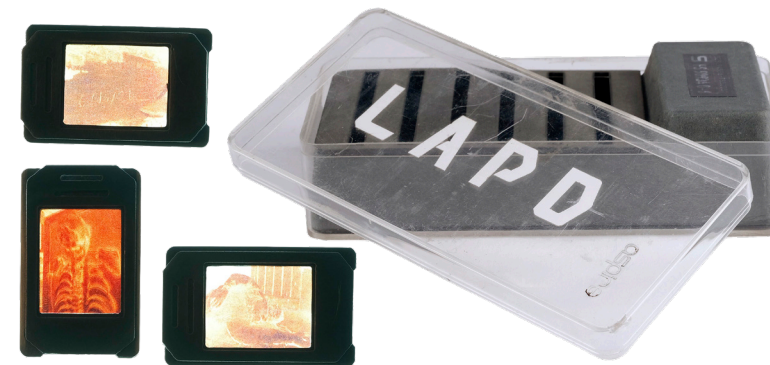

109
Set of Three of K's (Ryan Gosling) Evidence Slides
and Slide Case

A set of three of Officer K's (Ryan Gosling) blank evidence slides and slide case from BLADE RUNNER 2049. Officer K worked for the Los Angeles Police Department (LAPD) as a "blade runner," an officer who decommissioned rogue replicants-bioengineered humanoid servants that broke free of their human masters-and retired them. Officers completed evidence slides to catalogue physical evidence for future reference. The case was seen with the slide reader in the background of K's apartment.

This lot includes three blank white vellum-type evidence slides with fields labeled in black in English. The slides feature a top title that reads "LAPD" and "Los Angeles Police Department" with foreign letters underneath, all in black typeface.

According to production wrap documents, only one slide case was created for the film.

The slides exhibit folding, tearing, and smudged ink, but remain overall in good condition.

Starting Bid: \$500



110
Mariette's (Mackenzie Davis) Magnetic Tracking Device

Mariette's (Mackenzie Davis) Change 2 magnetic tracking device. Mariette was a Nexus-8 replicant who worked as a doxie, a skilled manipulator and sometimes even an assassin-who used human nature to achieve their goals. She was also a member of the replicant freedom group led by Freysa Sadeghpour (Hiam Abbass). Mariette planted a tracking device in Officer K's jacket after spending the night with him.

This lot features one silver-color cylindrical magnetic tracking device with a multicolor decal surrounding its circumference. Included in the lot is a transparent plastic zip-top storage bag with black and white decal labels that read "Mariette" and "Tracking Device" attached to its front.

According to production wrap documents, this is one of three magnetic tracking device props created for the film.

The decal on the tracking device exhibits slight lifting and the storage bag exhibits some creasing, but the lot remains overall in very good condition.

Starting Bid: \$250



114
Luv's (Sylvia Hoeks) Screen-Matched Quilted
White Coat with Red Turtleneck Costume

Luv's (Sylvia Hoeks) screen-matched quilted white coat and red turtleneck costume from BLADE RUNNER 2049. Luv, a Nexus-9 model replicant who was initially gifted to the LAPD by Niander Wallace (Jared Leto) to serve as a blade runner and set the standard for Nexus-9 performance, eventually became Wallace's personal assistant. The jacket screen-matches to the scene where Luv visited Lt. Joshi (Robin Wright) at her LAPD office to kill her and when she wore her red costume.

The costume's components are: • One long quilted white coat; • One maroon mock turtleneck long-sleeve shirt; • One gray skirt; • One wide matching gray belt; • One pair of black gloss patent and croco-embossed boots marked "4. Luv 39/46/0"

The coat is tagged "Luv 1" inside the left sleeve armpit and its hood has been fixed into place with tape. The coat features interior strapping to secure under the wearer's arms and is lined with a geometrically quilted black fabric.

According to production wrap documents, this is one of three quilted Luv white coats that were created for the film.

The lot remains overall in very good condition.

Starting Bid: \$2,500



115
Luv's (Sylvia Hoeks) Stunt Knife

Luv's (Sylvia Hoeks) stunt knife from BLADE RUNNER 2049. Luv, a Nexus-9 model replicant who was initially gifted to the LAPD by Niander Wallace to serve as a blade runner and set the standard for Nexus-9 performance, eventually became Wallace's personal assistant. In the final rain fight, Luv used two knives in her battle with Officer K (Ryan Gosling): a curved-blade knife, then her straight-blade stiletto-style knife as she stabbed K; Luv also used her straight-blade knife when she killed Lt. Joshi (Robin Wright).

This lot consists of one silver-color stunt knife cast in dense urethane with a long, triangular slender blade with a carved handle featuring line groupings and cross-hatching. The blade features a thin center channel carved completely through.

The knife exhibits nicks, abrasions, and finish wear but remains overall in good condition.

Starting Bid: \$500



116
Lt. Joshi's (Robin Wright) Black Coat Costume

Lt. Joshi's (Robin Wright) black coat costume from BLADE RUNNER 2049. Lt. Joshi was a member of the Retirement Division of the LAPD and Officer K's (Ryan Gosling) superior. Joshi wore her complete costume in the scene with Luv (Sylvia Hoeks) at her LAPD office where Luv confronted her about K's whereabouts before killing her.

The costume's components feature one black, long-sleeve coat; one light gray, sleeveless fitted dress; and one pair of black suede knee-high boots.

According to production wrap documents, this is one of three black coat costumes that were created for the film.

The dress exhibits a dry cleaning tag at its interior bottom, but the lot remains overall in very good condition.

Starting Bid: \$1,500



Front side and back side of emanator

118
K's (Ryan Gosling) Light-up Open Emanator Matched to Antennae Removal Scene

Officer K's (Ryan Gosling) light-up open emanator matched to the antennae removal scene from BLADE RUNNER 2049. Blade runners, including Officer K, worked for the Los Angeles Police Department (LAPD) to decommission rogue replicants-bioengineered humanoid servants that broke free of their human masters-and retire them. Emanators were used to "free" Joi (Ana de Armas) from the bounds of Officer K's apartment so she could travel outside its borders and interact with humans. This emanator was used in the scene in Deckard's apartment where Joi (Ana de Armas) told K to put her in the emanator and break the antennae even if it put her at risk. The emanator screen matches based on scratches on the body to close-ups of K removing and breaking the antennae.

This lot includes one black plastic and silver-color metal light-up open emanator shaped as a long, squarish tube with beveled edges along its entire length. A round light ring lies embedded in the device and "joi" and a small numeric figure are carved into the plastic. Also included are two broken-in-half antennae that were used with this prop, and an unbroken antennae.

According to production wrap documents, this is one of two prop light-up open emanators that was created for the film.

The emanator remains overall in very good condition.

Contains electronic elements; please see notice in the Buyer's Guide.

Starting Bid: \$500



119
Joi's (Ana de Armas) Fur Coat

Joi's (Ana de Armas) fur coat from BLADE RUNNER 2049. Joi was an artificial intelligence (AI) hologram that people-including Officer K (Ryan Gosling)-could purchase as a live-in romantic partner. Joi wore her fur coat and shirt when she accompanied K to visit Doc Badger (Barkhad Abdi) to have the carved wooden horse toy analyzed.

The costume's components are one shaggy purplish burgundy faux fur coat marked "CH.12 Hero" on a production tag and labeled "HERO" by hand; one navy blue boatneck pullover shirt with long sleeves; and a production bag labeled "Hotstock #3 Joi Sc. 35/N2 Ch. #7."

According to production wrap documents, only one hero fur coat costume was created for the film.

The pullover exhibits white smudging on the front, but the lot remains overall in very good condition.

Starting Bid: \$2,500





122
Rick Deckard's (Harrison Ford) Screen-Matched Hero LAPD 2019 PKD Detective Special Blaster

Blade runner Rick Deckard's (Harrison Ford) screen-matched LAPD 2019 PKD detective special blaster from BLADE RUNNER 2049. Deckard was the human father of a half human/half replicant child, Ana Stelline (Carla Juri), a scientist who designed memories for replicants with the help of Officer K (Ryan Gosling), otherwise known as the Nexus-9 Replicant, KD6-3.7. The memorable fan-favorite PKD blaster is the same style of blaster that Deckard used in the original Blade Runner film. This lot screen-matches, based on paintwork and scratches, to a close-up of K holding it in the rain before he pursued Luv's (Sylvia Hoek) spinner in the film's finale and also matches to a production photo of the gun in the scene with Freya (Hiam Abbass) meeting K.

This metal, double-barreled blaster features two triggers and a carved amber hand grip. It was built specifically for BLADE RUNNER 2049 using a commercially available prop replica of the Deckard blaster from the original film as a base. This example is missing its original light-up removable cartridge element from the underside of the gun and the side-mounted rod detail with green LEDs; this is how the prop was left by production. A replica removable light-up cartridge element has since been installed but it is not original to the production.

According to production wrap documents, this is one of four of this type of Deckard hero prop blasters that were created for the film.

Production used glue to stick the lever and cylinder in place so they would not move during filming. The lot remains overall in good condition.

Contains electronic elements; please see notice in the Buyer's Guide.

Starting Bid: \$10,000





123
Rick Deckard's (Harrison Ford) Costume with Matched Clean Shirt

Blade runner Rick Deckard's (Harrison Ford) costume with a matched clean shirt from BLADE RUNNER 2049. Deckard was the human father of a half human/half replicant child, Ana Stelline (Carla Juri), a scientist who designed memories for replicants with the help of Officer K, otherwise known as the Nexus-9 Replicant, KD6-3.7. The shirt screen-matches to the scene where Deckard first wore its clean version in his apartment, and the boots are stunt versions marked for water use in the scenes in the limo spinner where Deckard was submerged.

The costume's components are: • One gray button-up shirt; • One light gray T-shirt; • One pair of brownish gray cargo-type pants; • One pair of light brown, lace-up boots marked "102" on the inside and a boot production tag labeled "Water Boots 102 D. Stunt" (102 is the production code for Deckard Stunt); • One dark brown leather belt marked "102" (102 is the production code for Deckard Stunt); • Two production tags; • A production bag labeled "'Hotstock #2 Deckard Sc. 120, 120A, 121, 122, 129/D7 CH. 2."

The shirt exhibits fading and edge wear and an undone seam at the bottom of the left-hand chest pocket, the T-shirt exhibits tiny pinholes; the belt is slightly warped, and the boots exhibit minor scuffing, but the lot remains overall in good condition.

Starting Bid: \$5,000



124
Rick Deckard's (Harrison Ford) Johnnie Walker Black Label Whiskey Bottle

Blade runner Rick Deckard's (Harrison Ford) Johnnie Walker Black Label whiskey bottle from BLADE RUNNER 2049. Deckard was the human father of a half human/half replicant child, Ana Stelline (Carla Juri), a scientist who designed memories for replicants with the help of Officer K (Ryan Gosling), otherwise known as the Nexus-9 Replicant, KD6-3.7. Rick lived in an abandoned casino in Las Vegas that featured not only a full-size ballroom with booths and a stage, but a full-scale dining and drinking area with a full bar of assorted liquor. This was the hero bottle that he handled and poured whiskey from in his apartment.

This lot features one empty Johnnie Walker Black Label Whiskey bottle. It is clear glass with gloss black accents. The bottle is topped with a gloss black square stopper.

According to production wrap documents, only one hero Deckard Johnny Walker Black Label whisky bottle prop was created for the film.

The lot exhibits scuffs and marks but remains overall in good condition.

Starting Bid: \$1,000



125
Rick Deckard's (Harrison Ford) Distressed Leather Holster

Blade runner Rick Deckard's (Harrison Ford) distressed leather holster from BLADE RUNNER 2049. Deckard was the human father of a half human/half replicant child, Ana Stelline (Carla Juri), a scientist who designed memories for replicants with the help of Officer K (Ryan Gosling), otherwise known as the Nexus-9 Replicant, KD6-3.7. Deckard employed various methods of self-defense, including firearms, and this holster was custom-made for the film to fit Deckard's blaster but remained unseen in the film's final cut.

This lot includes one distressed brown leather holster with thick white stitching and matching edge paint. The holster exhibits wear to the edge paint, discoloration of the white stitching, weapon impressions to the leather, and nicks, scuffs, fading, and warping to the leather.

The lot remains overall in fair condition.

Starting Bid: \$250

**126****K's (Ryan Gosling) Distressed Costume with Coat Matched to Deckard's Apartment Scenes**

Officer K's (Ryan Gosling) distressed costume with signature coat matched to Deckard's apartment scenes, amongst others, from *BLADE RUNNER 2049*. Officer K worked for the Los Angeles Police Department (LAPD) as a "blade runner," an officer who decommissioned rogue replicants—bioengineered humanoid servants that broke free of their human masters—and retired them. The coat in this lot screen-matches to the interior of Deckard's (Harrison Ford) apartment where it was seen as a clean coat, as well as the scene with K in Bibi's Bar, and when K arrived in Las Vegas and walked around the abandoned statues in an orange light; it was later distressed and used as a bloodied coat in Deckard's apartment when K was on the floor wounded in the stomach by shrapnel and also when K looked at Joi's (Ana de Armas) sign in the rain as he held Deckard's blaster weapon. The bloodied shirt and undershirt were stored with the costume and likely worn with this exact coat.

The costume's components are: • One shearling collared, bloodied black leather insulated coat marked "K" (a label was originally present but has been removed); • One bloodied black textured sweater with a tag marked "Med"; • One bloodied gray long-sleeve shirt with a tag marked "K"; • One pair of dark khaki pants marked "K 3"; • One pair of gloves marked "8.5" with a knitted yarn liner and decorative repair stitching; • One pair of unmarked black leather and rubber boots; • Two production tags

The lot exhibits production-added distressing: the coat, sweater, and shirt all exhibit various stage blood residue and holes, the pants and gloves exhibit some scuffing and fading, and the boots exhibit scuffed and nicked rubber; the lot remains overall in production-distressed condition.

Starting Bid: \$10,000



10.7' (3.25 m)

127
Rick Deckard's (Harrison Ford) Penthouse Bar

Blade runner Rick Deckard's (Harrison Ford) penthouse bar from BLADE RUNNER 2049. Deckard was the human father of a half human/half replicant child, Ana Stelline (Carla Juri), a scientist who designed memories for replicants with the help of Officer K (Ryan Gosling), otherwise known as the Nexus-9 Replicant, KD6-3.7. Rick lived in an abandoned penthouse casino in Las Vegas that featured not only a full-size ballroom with booths and a stage, but a full-scale dining and drinking area with a full bar of assorted liquor. The bar was custom-made for the film and Deckard and K sat at the bar and shared a drink.

This wooden bar is in two halves that slot together in the middle. It features a pair of drawers and cupboards.

According to production wrap documents, only one penthouse bar prop was created for the film.

Special shipping required; see special shipping notice in the Buyer's Guide.

The bar has been intentionally distressed but features additional wear, including some of the metal detailing around the bar becoming detached, but the lot remains overall in good condition.

This lot is currently located in Propstore's London facility and will ship directly to the Buyer from the London facility. Buyer will be responsible for all shipping and import charges from the UK. Please inquire for additional information.

Starting Bid: \$10,000

129
Rick Deckard's (Harrison Ford) Books with Photo of Rachael (Sean Young)

Blade runner Rick Deckard's (Harrison Ford) books and photo of Rachael (Sean Young), a replicant, from BLADE RUNNER 2049. Deckard was the human father of a half human/half replicant child, Ana Stelline (Carla Juri), a scientist who designed memories for replicants with the help of Officer K (Ryan Gosling), otherwise known as the Nexus-9 Replicant, KD6-3.7. Rick lived in an abandoned penthouse casino in Las Vegas in swanky, hotel-like accommodations and kept a few personal items amongst the abandoned, decaying space and contents of the old establishment. The books weren't seen prominently but were intended for use in the scene and may have been part of the decor in Deckard's apartment. A photograph of Rachael (Sean Young) in a frame was viewed and may have been an alternate option in the decor.

This lot features one hardback copy of Treasure Island marked "Patte 1929 p125 no. 67" on the first page and "310 I am always sorry when any languages are lost, because languages are the pedigree of nations" on the last page; one hardback copy of Robinson Crusoe with various writings inside the cover, and one photograph of Rachael inserted between pages 138 and 139.

The books exhibit edgewear, scarred covers, and a buildup of grime on their pages and remain overall in fair condition.

Starting Bid: \$500

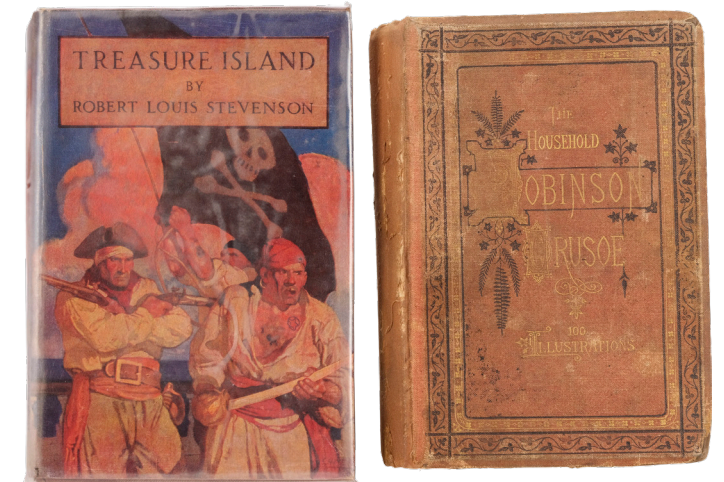
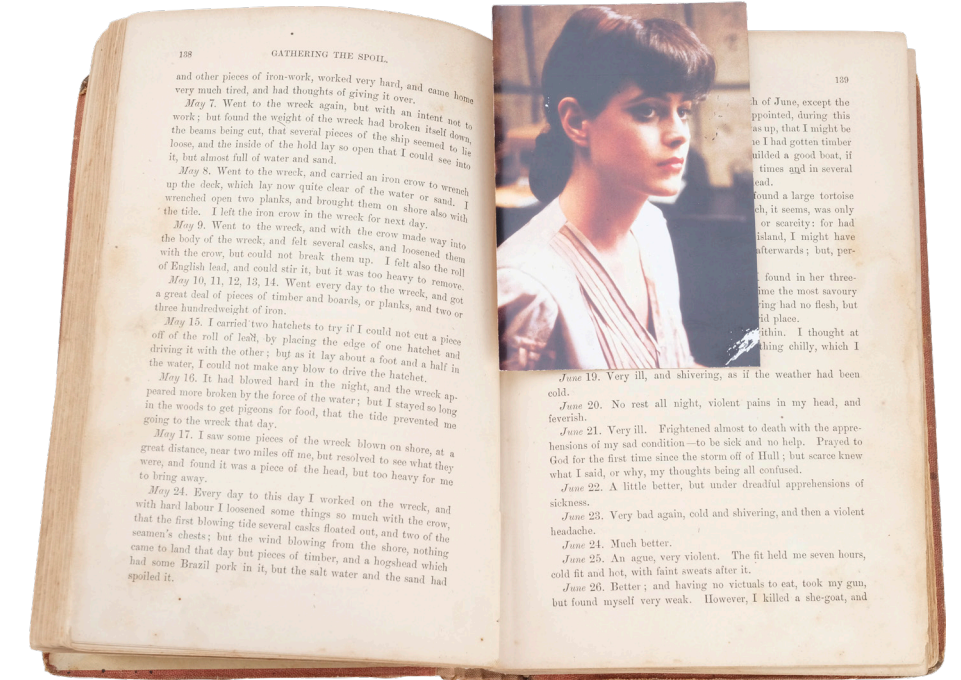

130
Set of Three of Rick Deckard's (Harrison Ford) Screen-Matched Carved Wooden Animals

Blade runner Rick Deckard's (Harrison Ford) set of three carved wooden animals from BLADE RUNNER 2049. Deckard was the human father of a half human/half replicant child, Ana Stelline (Carla Juri), a scientist who designed memories for replicants with the help of Officer K (Ryan Gosling), otherwise known as the Nexus-9 Replicant, KD6-3.7. Deckard lived in an abandoned penthouse casino in Las Vegas in swanky, hotel-like accommodations and kept a few personal items amongst the abandoned, decaying space and contents of the old establishment. The three creatures screen-match to the shot with Rachael's (Sean Young) photo in Deckard's apartment and were similar to K's carved wooden horse.

This lot features three wooden carvings: a lion, a unicorn, and a rhinoceros.

Each remains overall in very good condition.

Starting Bid: \$500



42.5"
(108 cm)

131
Rick Deckard's (Harrison Ford) Hydroponics Grow Pod

Blade runner Rick Deckard's (Harrison Ford) hydroponics grow pod from BLADE RUNNER 2049. Deckard was the human father of a half human/half replicant child, Ana Stelline (Carla Juri), a scientist who designed memories for replicants with the help of Officer K (Ryan Gosling), otherwise known as the Nexus-9 Replicant, KD6-3.7. Rick lived in an abandoned penthouse casino in Las Vegas in swanky, hotel-like accommodations and kept a few personal items amongst the abandoned, decaying space and contents of the old establishment. Edible vegetables were unavailable, so Deckard sustained himself with, among other things, algae-type nutrients grown in "grow pods."

This lot includes one gray and white plastic and mixed materials grow pod device that resembles a food blender. The device consists of a cylindrical container with a clear canister component that is partially filled with a light creamy green color product and the machine features button controls to process the canister's contents.

Contains electronics; see electronics notice in the Buyer's Guide.

Special shipping required; see special shipping notice in the Buyer's Guide.

The pod has been intentionally distressed to appear well-used and aged. It exhibits additional wear from use and storage, including cracks, scuffs and scratches, but remains overall in fair condition.

This lot is currently located in Propstore's London facility and will ship directly to the Buyer from the London facility. Buyer will be responsible for all shipping and import charges from the UK. Please inquire for additional information.

Starting Bid: \$500



132
Joi's (Ana de Armas) Turtleneck and Clear Yellow Jacket Ensemble

Joi's (Ana de Armas) turtleneck and clear yellow jacket ensemble from BLADE RUNNER 2049. Joi was an artificial intelligence (AI) hologram that people-including Officer K (Ryan Gosling)-could purchase as a live-in romantic partner. Joi wore her yellow jacket throughout the film, with this type of boots and sleeveless turtleneck sweater seen specifically in Deckard's (Harrison Ford) apartment.

The costume's components are: • One transparent yellow plastic long-sleeve thigh-length jacket; • One black sleeveless pullover turtleneck sweater; • One black textured pattern fabric miniskirt marked "3. Action"; • One pair of over-the-knee black leather and suede boots; • A boot tag labeled "Boots CH. 12 +13 3. Joi"; • One pair of black stockings; • Two production tags.

The turtleneck exhibits light smudges on the front just under the neckline; the yellow plastic jacket exhibits creasing throughout; and boots exhibit slight scuffs, but the lot remains overall in very good condition.

Starting Bid: \$5,000

133
K's (Ryan Gosling) Screen-Matched Black Sweater with Undershirt

Officer K's (Ryan Gosling) black sweater with undershirt from BLADE RUNNER 2049. K, a replicant, is the film's protagonist and title character and a "blade runner" who worked for the Los Angeles Police Department (LAPD) to decommission rogue replicants-bioengineered humanoid servants that broke free of their human masters-and retire them. K wore his sweater for the majority of the film, including scenes without his signature jacket. In the opening scenes, he wore a charcoal-color sweater before switching to a black sweater for the rest of the film. The sweater was purchased for the film but then modified with the addition of hand-stitched repair thread in several places, notably on the left shoulder. The sweater screen-matches to the scene with K in his apartment when he's visited by Lt. Joshi (Robin Wright) based on the unique hand-applied stitching on the left shoulder.

The costume's components are one black textured sweater and one gray long-sleeve undershirt marked "K."

All components exhibit frayed fabric and wear but remain overall in fair condition.

Starting Bid: \$1,000



136
Rick Deckard's (Harrison Ford) Light-up Binoculars

Blade runner Rick Deckard's (Harrison Ford) light-up binoculars from BLADE RUNNER 2049. Deckard was the human father of a half human/half replicant child, Ana Stelline (Carla Juri), a scientist who designed memories for replicants with the help of Officer K (Ryan Gosling), otherwise known as the Nexus-9 Replicant, KD6-3.7. Rick lived in an abandoned penthouse casino in Las Vegas and used binoculars to scan the dystopian horizon for intruders.

This lot consists of one pair of production-distressed binoculars composed of mixed materials including metal and plastic in black, red, and silver-color with a carrying strap. The eye sights are surrounded by a fitted face form for comfort. The binoculars feature a real optics system that allows the viewer to look through them. There is also an illuminating (electronic) red-colored readout within the eyepiece that is activated via a button on the right side. It also illuminates a red circle around the lens on the front side.

According to production wrap documents, this is the only binoculars prop created for the film.

The lot exhibits intentional paint chipping, nicks to the finish, and a buildup of grime, and remains overall in production-distressed condition.

Contains electronic elements; please see notice in the Buyer's Guide.

Starting Bid: \$2,500



137
Luv's (Sylvia Hoeks) Gray Costume

Luv's (Sylvia Hoeks) complete gray costume from BLADE RUNNER 2049. Luv, a Nexus-9 model replicant who was initially gifted to the LAPD by Niander Wallace to serve as a blade runner and set the standard for Nexus-9 performance, eventually became Wallace's personal assistant. Luv wore her complete costume with its signature moto jacket throughout many scenes in the film, including the latter part of the film where the confrontation at Rick Deckard's (Harrison Ford) apartment took place and in the sea wall scenes at the film's finale.

The costume's components are: • A gray jacket with a broad collar, peplum, and silver-color zippers; • One hematite-color, high-neck, sleeveless, princess-seamed shirt with a back zip closure marked "4"; • One pair of light gray pants with foot stirrups marked "CB" for "center back" (to identify the front of the pants, as they look very similar when viewed from either side); • One pair of black patent gloss and croco-embossed knee-high boots marked "4. Luv 39/46/0"; • One pair of black gloves marked "Luv"; • One production tag

The jacket is a non-bloody version but has purple staining from being stored wet after use in water scenes; purple dye transferred from the undershirt. The purple dye is not removable with basic cleaning methods, though a professional textile artist may be able to restore the garments. The boots exhibit slight scuffs, but the lot remains overall in very good condition.



Starting Bid: \$2,500

139
Luv's (Sylvia Hoeks) Hero Blaster

Luv's (Sylvia Hoeks) hero blaster from BLADE RUNNER 2049. Luv, a Nexus-9 model replicant who was initially gifted to the LAPD by Niander Wallace (Jared Leto) to serve as a blade runner and set the standard for Nexus-9 performance, eventually became Wallace's personal assistant. Blasters of different variations were a common weapon of choice for protagonists and antagonists throughout the film. Luv was seen using her blaster in the scene with the Rachael clone (Loren Peta) at Wallace headquarters and in the final battle scene with Rick Deckard (Harrison Ford) and Officer K (Ryan Gosling).

This lot features one light-up blaster with two barrels composed of metal, plastic, and mixed materials in black, silver-color, and gray finishes and an ergonomic grip. The blaster features electronic capabilities. A small microswitch at the back rear of the gun activates an LED light in the side of the frame and the electronic recoil mechanism, where an internal component slides back and forth within the barrels with the trigger is pulled. A rechargeable battery is contained within the grip.

According to production wrap documents, this is one of three hero Luv blasters that were created for the film.

It includes one battery charging dock with four batteries and one electrical wire and the lot remains overall in very good condition.

Contains electronic elements; please see notice in the Buyer's Guide.

Starting Bid: \$2,500



140
Luv's Security Team Hero Blaster

Luv's security team hero blaster from BLADE RUNNER 2049. Luv, a Nexus-9 model replicant who was initially gifted to the LAPD by Niander Wallace (Jared Leto) to serve as a blade runner and set the standard for Nexus-9 performance, worked with her security team in her pursuit of K (Ryan Gosling.) Blasters of different variations were a common weapon of choice for protagonists and antagonists throughout the film. This hero security team blaster was similar to Luv's but presented a different paint and color scheme. The security team used their blasters in Deckard's (Harrison Ford) apartment to kidnap him and ward off K.

This lot contains one double-barrel blaster composed of mixed materials in matte black and a black rubberized ergonomic grip. This blaster is considered a "hero" version and features a nicer finish than the stunt version of the security team blaster, but unlike the similarly-designed Luv pistol, was built without any electronics.

According to production wrap documents, this is one of two hero security team blasters that were created for the film.

The blaster exhibits minor wear to the edges of the matte black finish, but remains overall in very good condition.

Starting Bid: \$1,000



141
K's (Ryan Gosling) Broken Bloody Emanator

Officer K's (Ryan Gosling) broken, bloody LAPD emanator from BLADE RUNNER 2049. Blade runners, including Officer K, worked for the Los Angeles Police Department (LAPD) to decommission rogue replicants—bioengineered humanoid servants that broke free of their human masters—and retire them. Emanators were used to "free" Joi (Carla Juri) from the bounds of Officer K's apartment so she could travel outside its borders and interact with humans. Broken emanators were unseen in the final cut of the film. After the attack at Deckard's (Harrison Ford) apartment, Luv (Sylvia Hoek) stomped on K's eliminator, destroying it and "retiring" Joi in the process. This broken eliminator was made for that scene, though it wasn't clearly seen due to the way the scene sequence was shot.

This lot includes one broken, bloody black plastic emanator with a round light ring embedded in the device. The emanator exhibits stage blood residue and a bottom component tip that has broken away from the internal metal insert.

The bottom component tip exhibits jagged, broken edges where it separated from the main body.

The emanator remains overall in fair condition.

Starting Bid: \$500



142
Freysa's (Hiam Abbass) Sunglasses and Ring

Freysa Sadeghpour's (Hiam Abbass) sunglasses and ring from BLADE RUNNER 2049. Sadeghpour was a Nexus-8 replicant combat engineer and the leader of a replicant freedom group. Freysa wore her sunglasses and ring in the scene where she met Officer K (Ryan Gosling) and told him about the freedom group and about her role with the hybrid child.

The costume's components are one pair of black-framed plastic sunglasses with brown lenses, and a silver-color ring in a carved dome style with a production tag labeled "Ring Double Freysa Insert Unit June 2017."

According to production wrap documents, only one set of prop sunglasses and ring was created for the film.

The ring exhibits minor nicks to its surface, but the lot remains overall in very good condition.

Starting Bid: \$250





143
Niander Wallace's (Jared Leto) Navy Suit

Niander Wallace's (Jared Leto) navy suit from BLADE RUNNER 2049. Industrialist Niander Wallace was the visually impaired head of the corporation that made replicants. Wallace wore his navy suit when he met Rick Deckard (Harrison Ford) to discover the secrets behind replicant reproduction.

The costume's components are: • One navy suit; • One white button-up dress shirt; • One black six-button vest; • One navy blue wool paisley pattern tie; • One matching pair of navy dress pants; • One pair of gray socks with a navy blue dot pattern; • Two production tags: one reads "waistcoat," the other that reads "Armani suit."

The lot remains overall in very good condition.

Starting Bid: \$1,000



144
Cloned Rachael (Loren Peta) Screen-Matched Costume with Wig

A cloned "Rachael," (Loren Peta)-a computer-generated recreation of the original Rachael (Sean Young) character in BLADE RUNNER 2049. The Rachael clone was created by Niander Wallace (Jared Leto) to entice Rick Deckard (Harrison Ford) into revealing information about their potential child. The scale pattern of the "brooch" square and collar match to the scene where Deckard met the Rachael clone at Wallace headquarters.

The costume's components are: • One gray textured metallic thread coat marked "Rita - Hero" with faux black crocodile trim; • One matching pencil skirt; • One black and white vest-like undergarment; • One dark brown wig under a perforated wig cover pinned to a fabric-covered wig form labeled "Rita Picture Double 23X Loren Peta"; • One pair of black glossy heels in a shoe box labeled "New #23X Rita"; • 10 extra buttons; • One pair of insoles

"Rita" was the production's code name for the Rachael character so as not to spoil the surprise about Rachael's return.

The lot remains overall in very good condition.

Starting Bid: \$1,000

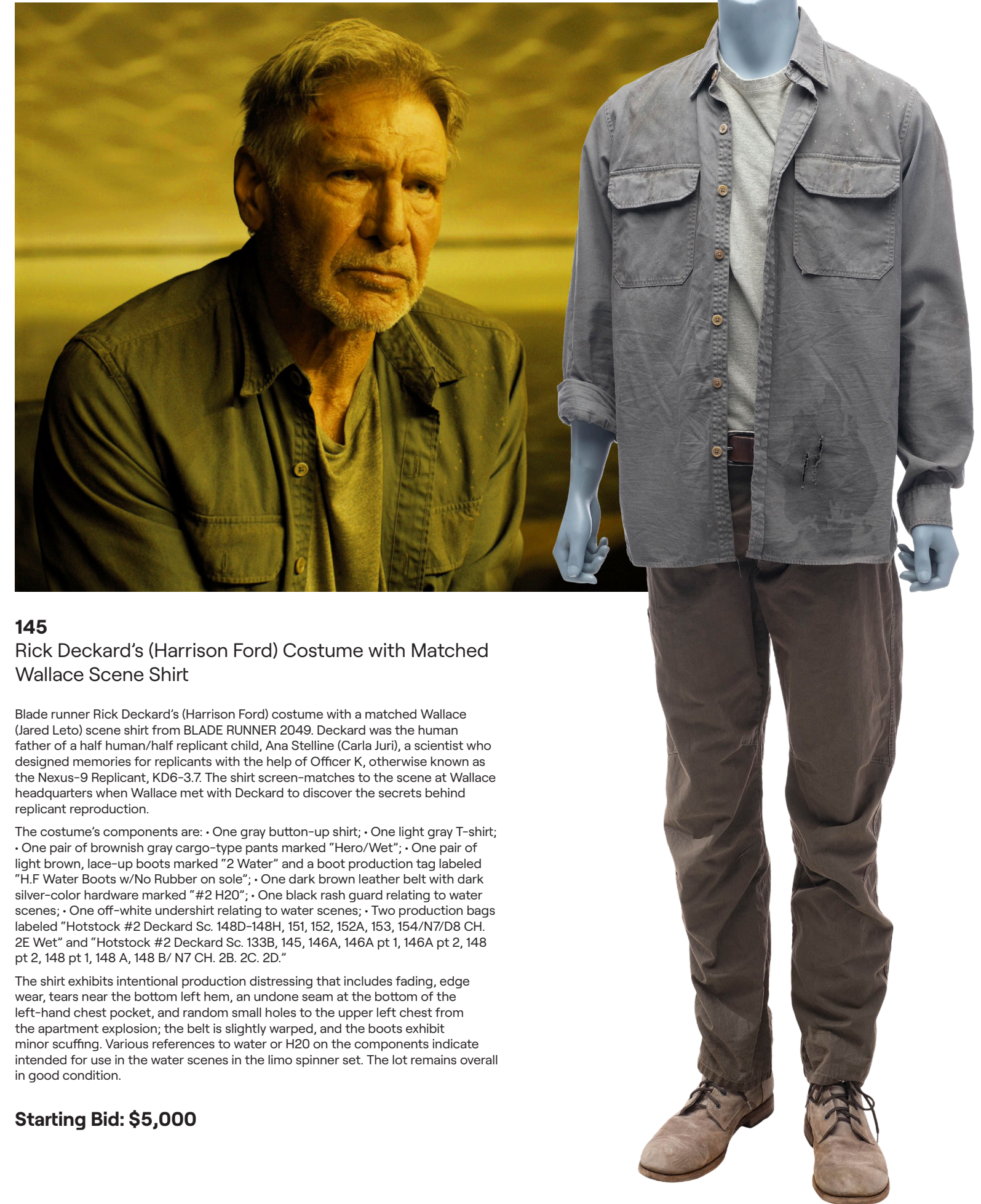

145
Rick Deckard's (Harrison Ford) Costume with Matched Wallace Scene Shirt

Blade runner Rick Deckard's (Harrison Ford) costume with a matched Wallace (Jared Leto) scene shirt from BLADE RUNNER 2049. Deckard was the human father of a half human/half replicant child, Ana Stelline (Carla Juri), a scientist who designed memories for replicants with the help of Officer K, otherwise known as the Nexus-9 Replicant, KD6-3.7. The shirt screen-matches to the scene at Wallace headquarters when Wallace met with Deckard to discover the secrets behind replicant reproduction.

The costume's components are: • One gray button-up shirt; • One light gray T-shirt; • One pair of brownish gray cargo-type pants marked "Hero/Wet"; • One pair of light brown, lace-up boots marked "2 Water" and a boot production tag labeled "H.F Water Boots w/No Rubber on sole"; • One dark brown leather belt with dark silver-color hardware marked "#2 H2O"; • One black rash guard relating to water scenes; • One off-white undershirt relating to water scenes; • Two production bags labeled "Hotstock #2 Deckard Sc. 148D-148H, 151, 152, 152A, 153, 154/N7/D8 CH. 2E Wet" and "Hotstock #2 Deckard Sc. 133B, 145, 146A, 146A pt 1, 146A pt 2, 148 pt 2, 148 pt 1, 148 A, 148 B/ N7 CH. 2B. 2C. 2D."

The shirt exhibits intentional production distressing that includes fading, edge wear, tears near the bottom left hem, an undone seam at the bottom of the left-hand chest pocket, and random small holes to the upper left chest from the apartment explosion; the belt is slightly warped, and the boots exhibit minor scuffing. Various references to water or H2O on the components indicate intended for use in the water scenes in the limo spinner set. The lot remains overall in good condition.

Starting Bid: \$5,000



146
Rick Deckard's (Harrison Ford) Photo-matched Hero Light-Up LAPD 2019
PKD Detective Special Blaster

Blade runner Rick Deckard's (Harrison Ford) photo-matched hero light-up LAPD 2019 PKD detective special blaster from BLADE RUNNER 2049. Deckard was the human father of a half human/half replicant child, Ana Stelline (Carla Juri), a scientist who designed memories for replicants with the help of Officer K (Ryan Gosling), otherwise known as the Nexus-9 Replicant, KD6-3.7. The memorable fan-favorite PKD blaster is the same style of blaster that Deckard used in the original Blade Runner film. Deckard used his blaster to defend himself against K when they first met. This prop photo matches to a production still featuring Harrison Ford based on unique scratches on the body.

This metal, double-barreled blaster features two triggers and a carved amber hand grip. It was built specifically for BLADE RUNNER 2049 using a commercially available prop replica of the Deckard blaster from the original film as a base.

According to production wrap documents, this is one of four of this type of Deckard hero prop blasters that were created for the film.

The blaster exhibits two triggers, a lever and cylinder stuck in the "down" position with putty, and notable paint wear throughout. The prop is missing one of the green LEDs from the left side, but is overall in good condition.

Contains electronic elements; please see notice in the Buyer's Guide.

Starting Bid: \$10,000





147
Luv's (Sylvia Hoeks) Distressed Gray Costume for Water Scenes

Luv's (Sylvia Hoeks) gray costume from BLADE RUNNER 2049. Luv, a Nexus-9 model replicant who was initially gifted to the LAPD by Niander Wallace (Jared Leto) to serve as a blade runner and set the standard for Nexus-9 performance, eventually became Wallace's personal assistant. The jacket screen-matches the underwater strangulation scene after Luv was shot, based on the distressing around the wound and folds and wrinkles in the jacket's lapel.

The costume's components are: • One gray jacket with a jacket tag marked "Blood Hero -Water Use Wet 4. Luv" (4 was the character number assigned to Luv by production); • One black sleeveless shirt marked "4"; • One pair of light gray pants with foot stirrups marked "CB," which stands for "center back" (to identify the front of the pants, as they look very similar when viewed from either side.); • One pair of black patent gloss and croco-embossed knee-high boots marked "4. Luv" with a boot tag marked "Water boot w/ neoprene boot inside CH. 7A. 4. Luv"; • One pair of black gloves marked "4" with a glove tag labeled "4 Luv Water Gloves x2 pr."; • A production bag labeled "HotStock #4 Luv Sc. 148 pt 2, 148A, 148C, 148E, 148F, 148G, 148H, 151A/N7 CH. 7A."; • A total of five production tags

The jacket exhibits stage blood at the right neck from the shirt, which is a non-bloody version but has purple staining from being stored wet, and the boots exhibit slight scuffs, but the lot remains overall in very good condition.

Starting Bid: \$2,500



148
Luv's (Sylvia Hoeks) White Coat Costume with Stunt Boots

Luv's (Sylvia Hoeks) white coat costume with stunt boots from BLADE RUNNER 2049. Luv, a Nexus-9 model replicant who was initially gifted to the LAPD by Niander Wallace (Jared Leto) to serve as a blade runner and set the standard for Nexus-9 performance, eventually became Wallace's personal assistant. Luv wore her white coat costume with her black shirt when she stole bones at the morgue. The quilted black interior of the lapels on the coat in this lot have an additional horizontal seam that is never visible in the film, which indicates the coat would have been intended for use only when "closed" with the black quilted lining not visible.

The costume's components are: • One white coat tagged "WHT Long Coat sc. 43, 44 72a, 84a, 112, 113, 114" and labeled "Camera Only"; with horizontal seam on lapel interiors; • One black shirt; • One pair of pants; • One pair of black gloss patent and croco-embossed boots; • Two inflatable boot inserts labeled "Stunt Chloe" for the stunt performer; • A boot tag labeled "Hero Boots (Chloe Bruce) sz. 37 #104 Luv Stunt"; • Two unpictured production tags

According to production wrap documents, this is one of three Luv white coats created for the film.

The lot remains overall in good condition.

Starting Bid: \$1,500



151
Luv's (Sylvia Hoeks) Stunt Blaster

Luv's (Sylvia Hoeks) stunt blaster from BLADE RUNNER 2049. Luv, a Nexus-9 model replicant who was initially gifted to the LAPD by Niander Wallace (Jared Leto) to serve as a blade runner and set the standard for Nexus-9 performance, eventually became Wallace's personal assistant. Luv used her blaster in her confrontation with K (Ryan Gosling) at the sea wall during the film's finale.

This lot includes one stunt blaster in light blue and silver-color mixed materials as well as a hard plastic, glossy black and light gray ergonomic grip.

The blaster remains overall in very good condition.

Starting Bid: \$1,000



170
Rick Deckard's (Harrison Ford) Photo-Matched Handcuffs with Nylon Strap

Blade runner Rick Deckard's (Harrison Ford) photo-matched handcuffs with nylon strap from BLADE RUNNER 2049. Deckard was the human father of a half human/half replicant child, Ana Stelline (Carla Juri), a scientist who designed memories for replicants with the help of Officer K (Ryan Gosling), otherwise known as the Nexus-9 Replicant, KD6-3.7. The handcuffs match to a production still of Deckard's hands and to the final fight scene where Deckard was handcuffed to a vessel that quickly filled up with water.

This lot includes one pair of black and silver-color metal handcuffs with a woven strap featuring cuffs that open and close with magnets.

The handcuffs exhibit missing pins that hold them closed, rust on the cuff hardware-likely from use in the underwater scenes-and a detached strap and metal bracket, but remain overall in fair condition.

Starting Bid: \$1,000





173
Luv's (Sylvia Hoeks) Stunt Curved Knife

Luv's (Sylvia Hoeks) stunt curved knife from BLADE RUNNER 2049. Luv, a Nexus-9 model replicant who was initially gifted to the LAPD by Niander Wallace (Jared Leto) to serve as a blade runner and set the standard for Nexus-9 performance, eventually became Wallace's personal assistant. In the final rain fight, Luv used two knives in her battle with Officer K (Ryan Gosling): a curved-blade knife, and a straight-blade stiletto-style knife as she stabbed K.

This lot consists of one silver-color stunt knife cast in dense urethane with a long, curved blade with a carved handle resembling a swath of folded fabric and a finger stop at the top of the grip.

The knife exhibits nicks but remains overall in good condition.

Starting Bid: \$500



174
Luv's Security Team Stunt Blaster

Luv's security team stunt blaster from BLADE RUNNER 2049. Luv, a Nexus-9 model replicant who was initially gifted to the LAPD by Niander Wallace (Jared Leto) to serve as a blade runner and set the standard for Nexus-9 performance, worked with her security team while pursuing K (Ryan Gosling.) Blasters of different variations were a common weapon of choice for protagonists and antagonists throughout the film, and the security team used theirs while fighting K (Ryan Gosling) and during Deckard's kidnapping.

This lot contains one blaster with two barrels composed of dense urethane and mixed materials in matte black and a black rubberized ergonomic grip.

The blaster exhibits minor wear to the edges of the matte black finish, but remains overall in very good condition.

Starting Bid: \$1,000



183
K's (Ryan Gosling) Light-Up Extendable Emanator with Black "JOI" Case, Orange Outer Box with Shipping Packaging

Officer K's (Ryan Gosling) LAPD light-up extendable emanator with black "JOI" case and orange outer box with shipping packaging from BLADE RUNNER 2049. Blade runners, including Officer K, worked for the Los Angeles Police Department (LAPD) to decommission rogue replicants-bioengineered humanoid servants that broke free of their human masters-and retire them. Emanators were used to "free" Joi (Ana de Armas) from the bounds of Officer K's apartment so she could travel outside its borders and interact with humans. K carried his emanator with him throughout the film and it appeared in multiple scenes. The orange box, black case, and shipping bag were seen when he first gifted the emanator to Joi.

This lot includes one emanator, a "hero" version, features an extendable and collapsible black casing that with an illuminating circular ring light. Also included one black emanator case marked JOI, one semi-translucent orange box, and an opened transparent columnar bubble wrap package.

The emanator exhibits slight creasing to the bubble wrap packaging, but remains overall in very good condition.

Contains electronic elements; please see notice in the Buyer's Guide.

Starting Bid: \$2,500

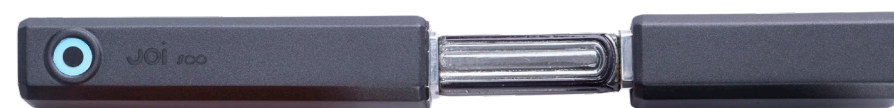

Emanator shown in open and closed positions



184
Rick Deckard's (Harrison Ford) Screen-Matched Handcuffs

Blade runner Rick Deckard's (Harrison Ford) handcuffs from BLADE RUNNER 2049. Deckard was the human father of a half human/half replicant child, Ana Stelline (Carla Juri), a scientist who designed memories for replicants with the help of Officer K (Ryan Gosling), otherwise known as the Nexus-9 Replicant, KD6-3.7. The lot matches the shot of Deckard's hands underwater in the final fight scene based on wear and distressing at the edge of the handcuffs' frame.

This lot includes one pair of broken black and silver-color metal handcuffs with green tape marked "BROKEN" taped around one cuff.

The handcuffs feature a locking pin for one cuff and exhibit rust, likely from use in the underwater scenes, but remain overall in fair condition.

Starting Bid: \$1,000





186
Rick Deckard's (Harrison Ford) Costume

Blade runner Rick Deckard's (Harrison Ford) costume from BLADE RUNNER 2049. Deckard was the human father of a half human/half replicant child, Ana Stelline (Carla Juri), a scientist who designed memories for replicants with the help of Officer K (Ryan Gosling), otherwise known as the Nexus-9 Replicant, KD6-3.7. Deckard wore his complete costume in the meeting with Wallace (Jared Leto) at Wallace headquarters and in the final fight scene with Luv (Sylvia Hoeks) and K. The shirt was distressed from the explosion at Deckard's apartment.

The costume's components are: • One gray button-up shirt; • One light gray T-shirt; • One pair of brownish gray cargo-type pants; • One pair of light brown, lace-up boots; • One dark brown leather belt marked "2" with dark silver-color hardware; • One pair of gray and black rib knit sock; • One production tag labeled "#2 Deckard Boxers t-shirt shirt pants belt boots socks."

The button-up shirt has been distressed by production and exhibits white marks at the left shoulder and both cuffs, a dark stain and tears near the bottom left hem, and an undone seam at the bottom of the left-hand chest pocket. The T-shirt exhibits tiny pinholes and slight discoloration; the belt is slightly warped, and the boots exhibit minor scuffing, and the lot remains overall in fair condition.

Starting Bid: \$5,000



Shown in open and closed positions

196
K's (Ryan Gosling) Light-Up Retractable Eye Scanner with VFX Screen

Officer K's (Ryan Gosling) LAPD light-up retractable eye scanner with VFX screen from BLADE RUNNER 2049. Blade runners, including Officer K, worked for the Los Angeles Police Department (LAPD) to decommission rogue replicants-bioengineered humanoid servants that broke free of their human masters-and retire them. K used a scanner on Sapper Morton (Dave Bautista) to confirm his identity as a replicant.

This lot includes one black, light-up retractable eye scanner with an VFX screen that features operational switches, buttons, and a scanning lens, which lights up when an external button on the scanner's edge is depressed.

The scanner exhibits the need for new batteries as well as minor nicks to the finish, but the lot remains overall in good condition.

According to production wrap documents, this is one of three light-up eye scanners that were created for the film.

Contains electronic/electric elements; please see notice in the Buyer's Guide.

Starting Bid: \$2,500

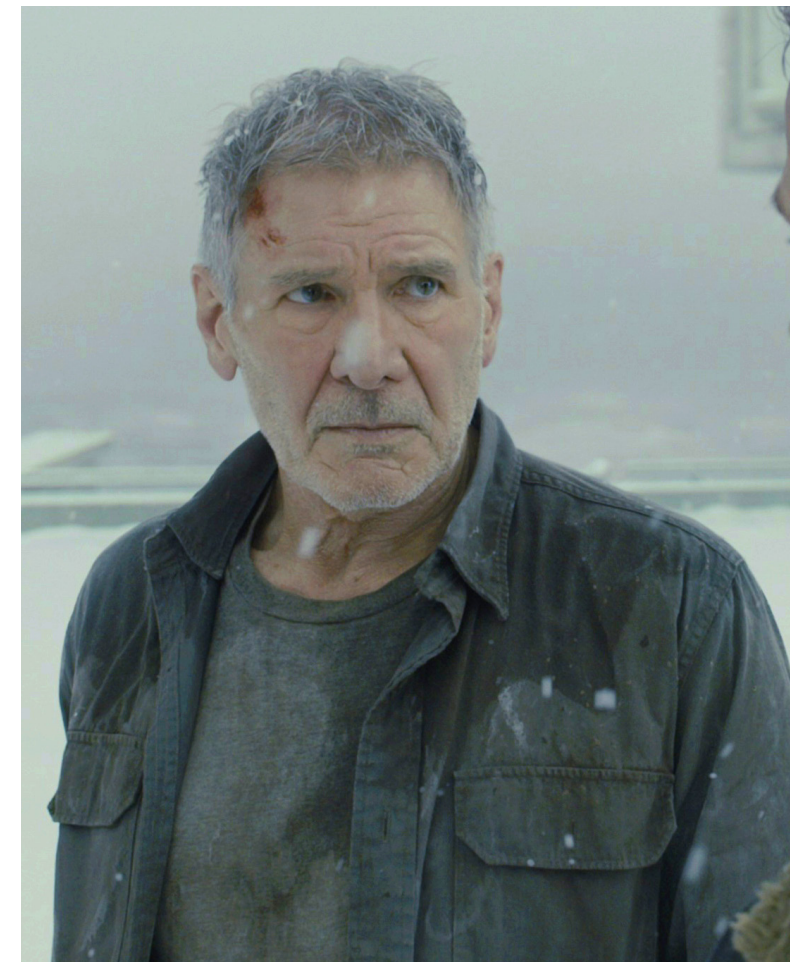

197
Rick Deckard's (Harrison Ford) Screen-Matched Seawater-Distressed Costume

Blade runner Rick Deckard's (Harrison Ford) screen-matched seawater-distressed costume from BLADE RUNNER 2049. Deckard was the human father of a half human/half replicant child, Ana Stelline (Carla Juri), a scientist who designed memories for replicants with the help of Officer K (Ryan Gosling), otherwise known as the Nexus-9 Replicant, KD6-3.7. The button-up shirt screen-matches to the final scenes of the film based on the salt weathering stains.

The costume's components are: • One gray button-up shirt; • One light gray T-shirt; • One pair of brownish gray cargo-type pants; • One pair of light brown, lace-up boots marked "102" (102 is the production code for Deckard stunt); • One blue ergonomic shoe insert; • One pair of gray socks; • One dark brown leather belt; • One production tag labeled "Triboro #2 Deckard 2F D8 155, 155pt1, 159, 162"; • One production bag labeled "Hotstock #2 Deckard Sc. 155, 155 pt 1, 159, 162/D8 CH. 2F" and "Blade Runner 4/5"

The shirt exhibits fading, tears, stains, white discoloration, and edge wear as well as an undone seam at the bottom of the left-hand chest pocket; the socks exhibit small holes and white discoloration; the T-shirt and pants both exhibit white discoloration and grime buildup; and the boots are scuffed and creased. The lot remains overall in production-distressed condition.

Starting Bid: \$5,000





198
K's (Ryan Gosling) Stunt LAPD 2049 Blaster

Officer K's (Ryan Gosling) stunt LAPD 2049 blaster from BLADE RUNNER 2049. Officer K worked for the Los Angeles Police Department (LAPD) as a "blade runner," an officer who decommissioned rogue replicants—bioengineered humanoid servants that broke free of their human masters—and retired them. This blaster is a key new design for the movie and plays prominently throughout the film. It was intended as an updated version of the Rick Deckard (Harrison Ford) blaster from the original film. K used his blaster throughout the film.

This blaster was custom designed and built for the films. The lot contains one stunt blaster with two barrels composed of dense urethane in matte black and a black and grey checkerboard pattern on the ergonomic grip, without functioning lights.

According to production wrap documents, this is one of three prop stunt K blasters that were created for the film. The blaster exhibits minor wear to the edges of the matte black finish, but remains overall in very good condition.

Starting Bid: \$5,000



199
Rick Deckard's (Harrison Ford) Photo and Poster-Matched Stunt Light-up LAPD 2019 PKD Detective Special Blaster

Rick Deckard's (Harrison Ford) photo and poster-matched stunt light-up LAPD 2019 PKD Detective Special Blaster 03 from BLADE RUNNER 2049. Deckard was the human father of a half human/half replicant child, Ana Stelline (Carla Juri), a scientist who designed memories for replicants with the help of Officer K (Ryan Gosling), otherwise known as the Nexus-9 Replicant, KD6-3.7. Deckard used his blasters to defend himself when he first met K before K took the blaster. This stunt prop matches to a production photo of the blaster in K's jacket pocket while he sits in a chair at Deckard's apartment. It also matches the image of Deckard on the primary one-sheet poster that also features K, Joi, and Wallace, based on distinct wear to the painted finish.

This lot includes one light-up blaster in black and dark silver-color mixed materials—primarily rubber—with a textured amber color rubber grip. It features working lights—the light-up cartridge element is hard plastic.

According to production wrap documents, this is one of three stunt Deckard blasters that were created for the film. It is the only one of the three with functional LED lights.

The blaster exhibits paint wear throughout and surface abrasions but remains overall in good condition.

Contains electronic elements; please see notice in the Buyer's Guide.

Starting Bid: \$5,000

200
K's (Ryan Gosling) Screen-Matched
Seawater-Distressed Costume

Officer K's (Ryan Gosling) screen-matched seawater-distressed costume from BLADE RUNNER 2049. Officer K worked for the Los Angeles Police Department (LAPD) as a "blade runner," an officer who decommissioned rogue replicants—bioengineered humanoid servants that broke free of their human masters—and retired them. The costume screen-matches to the final water and snow scenes and the sweater screen-matches shots of K in Lt. Joshi's (Robin Wright) apartment after his failed baseline test. The sweater was later modified to be a bloody version and used in the final scene outside of Dr. Ana Stelline's (Carla Juri) lab where it was stained with seawater from the sea fight.

The costume's components are: • One shearing collared, black leather insulated bloodied coat marked "Stunt" and a yellow tag labeled "Triboro #1 K Sc. 161 only" (note: the coat is labeled Stunt and may have been used for stunt sequences as well, but screen matches to Gosling in the final scenes in the film.); • One unmarked bloody sweater with snowflake remnants and a hole in front; • One long-sleeve undershirt marked "K" at the interior bottom; • One bloodied pair of khaki color pants marked "6" and "K 6"; • One fabric bandage for the left hand with a red tag labeled "K" and "SC 161"; • One pair of unmarked brown leather gloves with decorative repair stitching; • One pair of black mixed material boots marked "Stunt"; • One production tag labeled "Triboro #1 K 4.U D.8."

The lot exhibits overall tears, stage bloodstains, holes, snowflake residue, and white staining and remains overall in production-distressed condition.

Starting Bid: \$10,000





Ext. Sea Wall Set
Behind-the-Scenes Production Still



propstore.com/BR2049

2025 Alcon Entertainment, LLC. All rights reserved