

Propstore

# Entertainment Memorabilia Live Auction



Treasures from  
Film and Television



Los Angeles

June 28 - 30, 2023

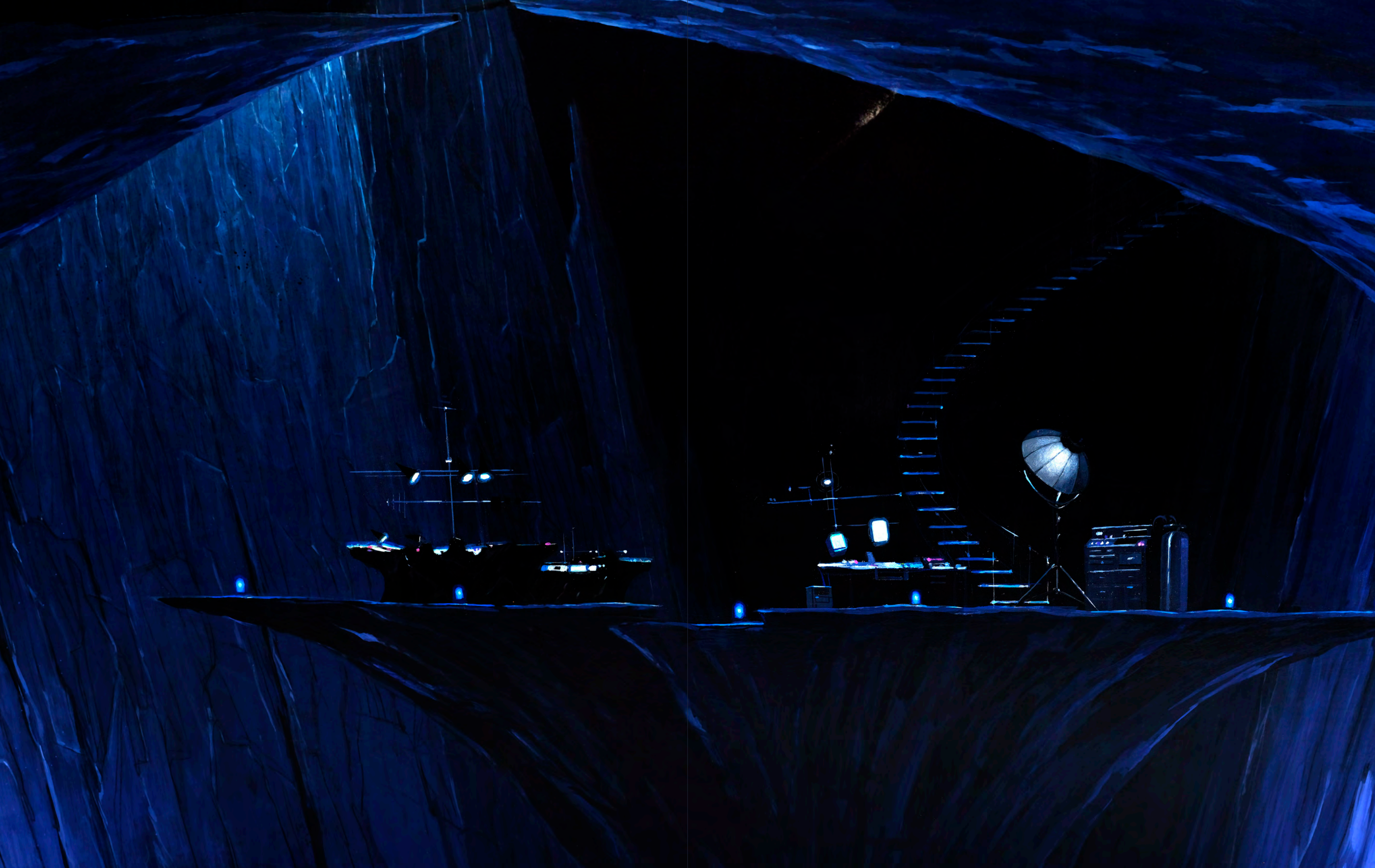

## Entertainment Memorabilia Live Auction

**June 28 – 30, 2023**  
**8:00 AM (PDT) / 4:00 PM (BST)**

**Hosted Live from the Petersen Automotive Museum**  
**4th Floor Penthouse**  
**6060 Wilshire Blvd**  
**Los Angeles, CA 90036**  
**Phone: 323-930-2277**

Bidding is available in-person (June 28 only), online, via telephone and via written absentee form. Bidders are advised to arrive early to register for in-person bidding (on June 28 only). Bidders are also advised to register in advance of the auction days for online, telephone or absentee bidding. Please see the bidding registration document at the back of the catalog for additional information. Please note in-person bidding is not available on Days 2 & 3 (June 29-30); bids can be placed on Days 2 and 3 online, via telephone or written absentee form.

Lots are auctioned live and in-person by Propstore's auctioneer in sequential order. The catalog identifies which day each lot will be offered. The live auction is streamed online at Propstore.com so bidders can follow all auction activity.

### Online Auction Catalog & Additional Lot Information

The online catalog for this auction contains multiple high-resolution photographs for all lots offered. Reviewing the online catalog prior to bidding is highly recommended. Absentee bids can also be placed in the online catalog.

Video footage is available for select lots, and condition reports are available upon request.

### Previewing Auction Lots

Lots can be previewed by special appointment at Propstore's Los Angeles facility. These special appointment previews can be facilitated through June 20. Lots can also be previewed via electronic video calls. Contact us for additional information.

### How To Bid

#### In-Person

Bidders are invited to attend Day 1 (June 28) of the live auction event in-person at the Petersen Automotive Museum. Please arrive early to register for the auction; you will complete a copy of the bidder registration form on page 713. Days 2 & 3 (June 29 & 30) of the auction will not be open to the public for in-person bidding.

#### Telephone

Complete the bidder registration form on page 713 and submit to Propstore to bid via telephone. One of Propstore's telephone bidding specialists will call you at your specified number and allow you to bid on your lot in real time.

#### Online

Bid live from anywhere in the world via Propstore's live online Auction Platform. Register today at Propstore.com/Auction

#### Absentee Form

Complete the bidder registration form on page 713 and submit to Propstore to bid via written absentee form; select the option for absentee bids and list your maximum bids. A clerk executes bids on your behalf in the room, up to the level necessary to beat other bidders.

### Terms & Info

#### Buying with Propstore

For an overview of how to participate in this auction as a buyer, please refer to the Buyer's Guide on page 698 of this catalog.

#### Conditions of Sale

This auction is governed by important stipulated terms, conditions and reserves.

### Buyer's Premium and Credit Card Fee

A Buyer's Premium of 25% will be added to all winning bids. A fee of 2% of the Purchase Price will be added for all orders paid via credit card if Purchase Price is greater than \$5,000.

#### FRONT COVER IMAGE

**318**  
Screen-Matched Evil Clown Doll  
**Poltergeist (1982)**

Propstore CA Bond # 72BSBGU4116

Additional video coverage is available on Propstore's YouTube and Instagram channels, and multiple live video streams showcasing auction Lots will run on Propstore's social media in the weeks before the auction.

### Petersen Automotive Museum Preview Event

Propstore will host a pre-auction reception at the Petersen Automotive Museum from 5:00 PM to 10:00 PM (PDT) on Saturday, June 24, 2023. Select lots will be on display at the reception. Bidders are invited to attend the pre-auction reception; please RSVP to supportla@propstore.com to confirm attendance.

#### Payment Plans

Payment plans may be available in increments of up to three (3) months for purchases where total Hammer Price and Buyer's Premium are greater than \$1,000. Buyers wishing to utilize the payment plan service, if approved by Propstore, shall be required to pay a deposit of twenty percent (20%) of the Purchase Price (the "Deposit"), within seven (7) days of being invoiced. The balance of the Purchase Price shall then be split over up to three (3) months, at the Buyer's option. Note that select notes, as indicated in the description, will not have the payment plan option available. Contact Propstore in advance of bidding with any questions on payment plans.

#### Reserves

Certain Lots in this auction may be sold without a Reserve Price; the majority of Lots in this auction are sold with a Reserve Price. The Reserve Price is the minimum price the Seller will accept for a Lot. The Reserve Price will not be more than the lowest estimate given by Propstore. Propstore may disclose or keep confidential the Reserve Price at its entire discretion.

#### Live Auction Stream

The complete live auction event will be broadcast on propstore.com and viewable from anywhere in the world. Lots are sold in sequential order.

#### Bidding Increments

The following are suggested bid increments for the Auction. Please be advised that they are suggested increments only, are not intended to be and shall not be binding, and the Auctioneer retains the sole and absolute discretion, at the time of the Auction, to change, modify, or vary the bid increments at any time.

- \$100 – \$300 by \$25
- \$300 – \$500 by \$50
- \$500 – \$2,000 by \$100
- \$2,000 – \$5,000 by \$250
- \$5,000 – \$10,000 by \$500
- \$10,000 – \$20,000 by \$1,000
- \$20,000 – \$50,000 by \$2,500
- \$50,000 – \$100,000 by \$5,000
- \$100,000+ at the Auctioneer's discretion

#### Sales Tax

Depending on your location, your auction lots may be subject to sales tax. Please see our sales tax quick reference guide at the top of page 704.

Follow the auction on Propstore's social media platforms **#PropstoreLiveAuction**



# Propstore

# Entertainment Memorabilia Live Auction

June 28 – 30, 2023



Los Angeles

[propstore.com/liveauction](https://propstore.com/liveauction)

## Day 1

Lots 1 – 523

June 28

Live Bidding

Petersen Automotive Museum

## Day 2

Lots 524 – 1014

June 29

Online, Telephone and

Absentee Bidding Only

## Day 3

Lots 1015 – 1487

June 30

Online, Telephone and

Absentee Bidding Only

Auction Begins 8:00am (PDT) / 4:00 PM (BST) Each Day

All days streamed live at propstore.com

\* Certain films and shows have Lots offered on more than one day of the Auction; see Index on page 706 for a complete listing of available Lots by film or show title

### About Propstore

Propstore was founded on the belief that the props and costumes used in movies are pieces of art—film art. We see these artifacts not as mere products of the production process, but as unique, creative works in their own right. The result of the collective effort of designers, fabricators, and artisans from every corner of the globe, many of these pieces are simply extraordinary.

Private collectors have played a significant role in preserving these film art pieces since the earliest days of cinema and television. Throughout the entertainment industry's history, these items were considered as mere production tools and were therefore commonly discarded time and time again. Private collectors have stepped in on many occasions and taken preservation into their own hands. Some film and television artifact collecting stories are legendary: A college student walking through a field and stumbling upon the model miniature space station from 2001: A Space Odyssey after the item was dumped from an unpaid storage locker, for example. Many of cinema's most memorable treasures are cared for by private collectors, and we believe that private collectors continue to play a critical role in the overall preservation and legacy of film and television history. Collecting is a very personal thing as all collectors have different tastes—but collectors are united through a common passion for the material and its preservation.

Each of Propstore's team members share this belief and are long-time, passionate collectors themselves. We love this material. We revere this material. Our enthusiasm is the driving force in our nearly two decade global search to locate these culturally-significant items. Our journey has enabled us to forge key relationships within the industry that have provided access

to material previously believed to be unavailable. We are also in continuous contact with those on the front lines of production. These individuals educate us and assist us in properly identifying and authenticating material. In turn, we have educated and supported the collecting community by sharing our knowledge through articles, videos and collecting websites and forums.

We are excited to share this catalog with collectors around the world. Within this sale you will find pieces available at every price point—all of which are authenticated and certified with our industry-leading certificate of authenticity and its accompanying guarantee. Each of these pieces satisfy our strict internal authentication standards.

We strive to present these pieces with the same level of care that went into their presentation on screen, as they deserve nothing less. A large portion of the artifact collection will be on public exhibition prior to the sale, providing a first-hand view of the material. Whether you are a veteran collector or just getting started, we hope that you find pieces that speak to you amongst this truly unique offering. To make this material more accessible, every item can be purchased on an interest-free payment plan. We can also pack and ship material safely to any destination in the world.

Our experience, passion and desire to source the most exciting pieces possible makes us one of the world's leading vendors of original props, costumes and collectible memorabilia. We look forward to being a part of your own collecting journey and to helping you preserve these beloved pieces of film and television history.

### The Propstore Certificate of Authenticity

Authenticity is the defining collectible element for original film and television props and costumes. All of our certificates carry multiple security elements to verify authenticity, representing a lifetime guarantee that the item is a genuine piece of cinema history exactly as described. Propstore's complete Terms of Guarantee can be found on page 703.



# Propstore

# Wanted

## Props, Costumes and Artifacts from Movies and Television

Sell Your Memorabilia with Propstore to Maximize Your Return

**Star Wars: A New Hope (1977)**  
Screen-Matched ILM Red Leader X-wing Model Miniature

sold for \$2,375,000

incl. bp



[propstore.com/sell](https://propstore.com/sell)



# Day 1

Lots 1 - 523.  
June 28, 2023



\*Certain films and shows have Lots offered on more than one day of the Auction; see Index on page 706 for a complete listing of available Lots by film or show title.

80" (203.25 cm)

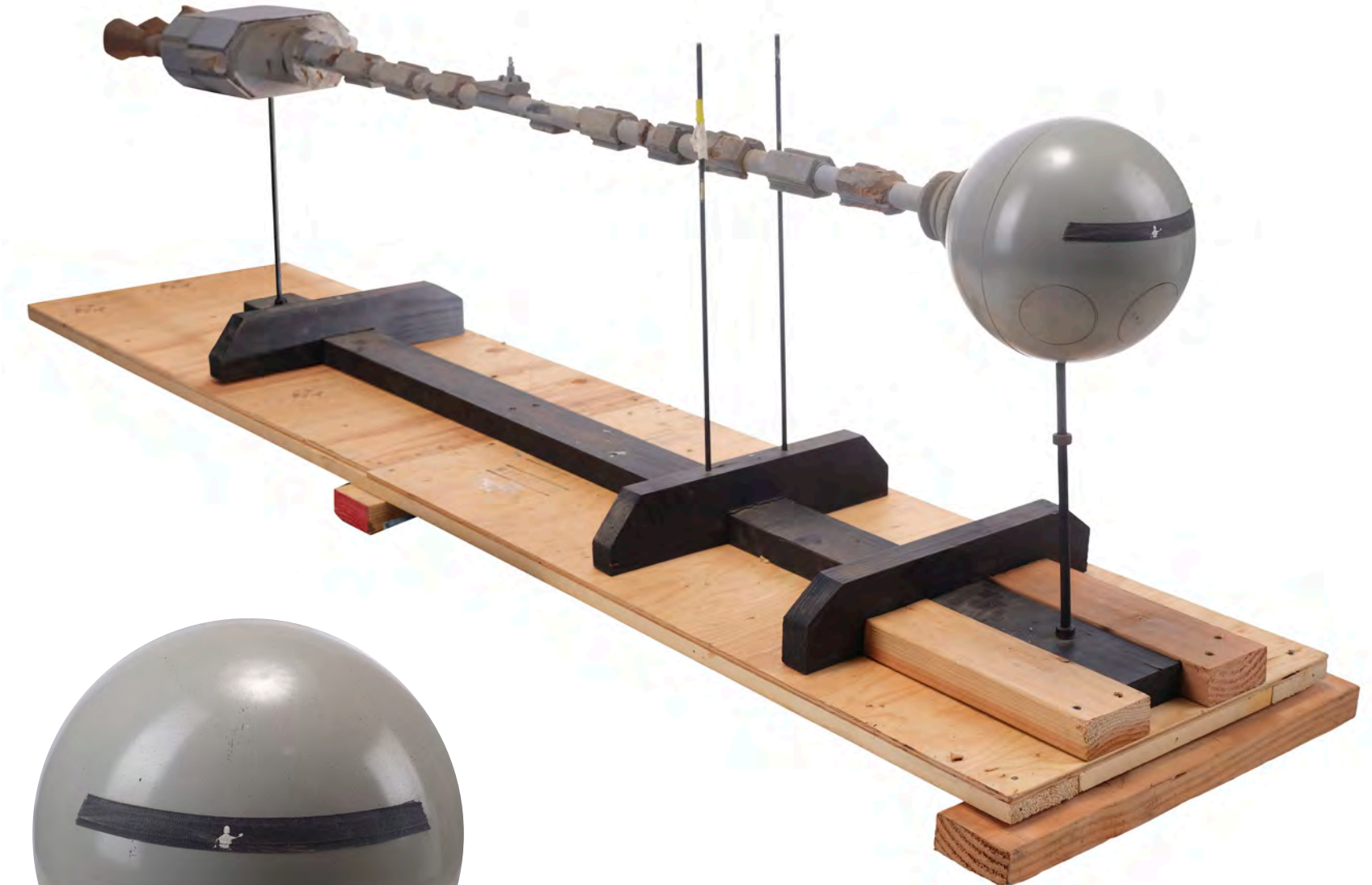
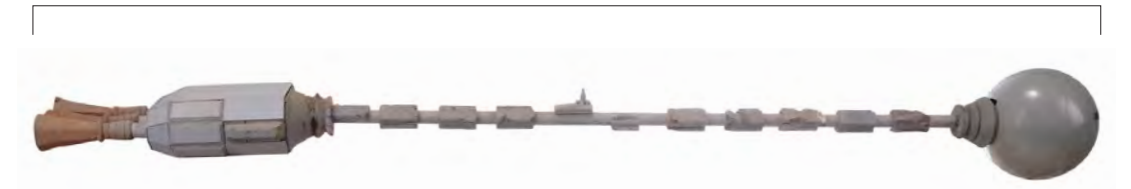

## 1 Boss Film Studios Discovery Study Model 2010: The Year We Make Contact (1984)

A Discovery study model made by effects company Boss Film Studios for the production of Peter Hyams' sci-fi sequel 2010: The Year We Make Contact. Study models are used for working out the proportion of a model by studying its design in a 3D space.

This ornately detailed model is constructed from mixed media, including cast resin, vacuum-formed plastic and wood, and hand-painted industrial gray and applied with grime to appear abandoned. It comes mounted via metal rods to a wooden display base inside a custom shipping crate. Also included is a Letter of Authenticity from visual effects supervisor Richard Edlund. The model's central section is wrapped with tape for stability and exhibits fracturing, chipping resin, and paint scuffing throughout. Dimensions: 80" x 10" x 19" (203.25 cm x 25.5 cm x 48.25 cm)

Special shipping required; see notice in the Buyer's Guide.

**Estimate: \$5,000 - 10,000**



**2**  
**Ben Wade's (Russell Crowe) Screen-Matched Costume**  
**3:10 To Yuma (2007)**

Ben Wade's (Russell Crowe) screen-matched costume from James Mangold's Western adventure 3:10 to Yuma. This hat screen-matches to scenes throughout the film, and the overcoat matches to Wade's introduction scene.

Originating from Russell Crowe's personal collection, this costume consists of a black felt hat with an embroidered band featuring turquoise stones; a black velveteen overcoat; a diamond-patterned black cotton vest; a gray cotton long-sleeve shirt marked labeled "RC Oct 2006" at the neck; a beige cotton long-sleeve thermal; and black felted polyester trousers featuring a reinforced leather cup for horseback riding, braided accents, and a button placket. Also included are a brown leather belt with brass-color hardware and a gun holster to complete the costume; a black velveteen pouch with earplugs; and a Letter of Authenticity from Crowe. The belt is a replica made by Will Ghormley, who made the original for the film. This costume exhibits discoloration, fading, snagged fibers and threads, and loose components.

**Estimate: \$10,000 - 20,000**



Entertainment Pictures / Alamy Stock Photo



**3**  
**Spartan Soldier Uniform with Shield and Spear**  
**300 (2006)**

A Spartan soldier's uniform with a shield and spear from Zack Snyder's historical action epic 300. King Leonidas (Gerard Butler) of Sparta led his army against the invading forces of King Xerxes of Persia (Rodrigo Santoro).

This lot consists of a bronze-color fiberglass helmet with brown leather cheek pads marked for stunt performer Ryan Watson; matching urethane gauntlets and greaves, both marked for stunt performer Rich Cetrone; a red burlap cape with leather embellishments marked for Marc Trottier and Jean-Francois Berube; a brown leather codpiece marked "T. Connelly [sic];" a plastic and fiberglass shield with nylon straps and a leather-wrapped handle; and a leather-wrapped wooden spear with a urethane head and resin base painted gray. Also included are three Certificates of Authenticity from Warner Brothers. The costume components were intentionally distressed by production to distinguish their use earlier in the Battle of Thermopylae. The lot exhibits loose components, and scuffed paint. Dimensions: (spear) 94" x 3" x 3" (238 cm x 7.75 cm 7.75 cm)

Special shipping required; see notice in the Buyer's Guide.

**Estimate: \$7,000 - 14,000**





56" (66 cm)

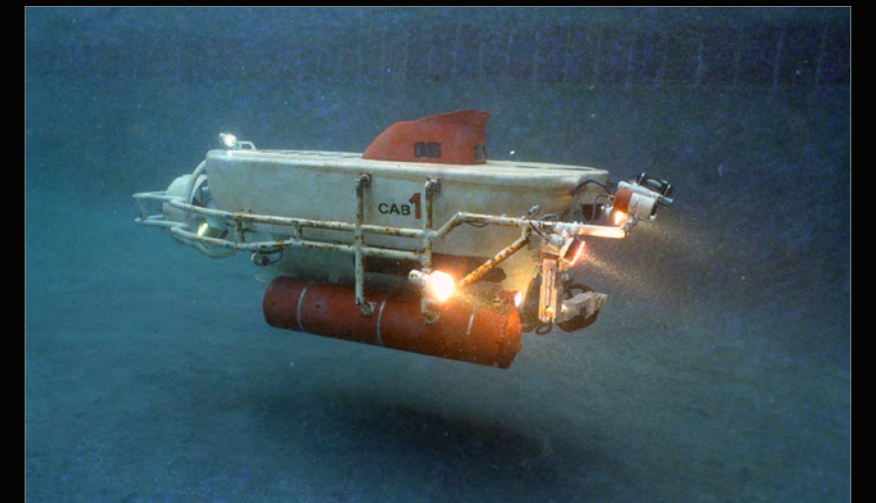

**4**  
**Light-Up 1/4-Scale Submersible Cab One Submarine Model Miniature**  
**The Abyss (1989)**

A light-up 1/4-scale submersible Cab One submarine model miniature from James Cameron's sci-fi adventure *The Abyss*. After Lieutenant Hiram Coffey (Michael Biehn) escaped in the mini-sub Flatbed with a primed warhead, Virgil "Bud" (Ed Harris) and Dr. Lindsey Brigman (Mary Elizabeth Mastrantonio) chased after him in Cab One, damaging both submersibles.

The Academy Award® winning movie, reputed for its intense filming that took a toll on its cast, would later become a cult classic, particularly after the release of the 1993 special edition that tightened its pacing.

This radio-controlled, 1/4-scale Cab One miniature is the only one created by visual effects supervisor Walt Conti for the chase sequence and resulting submarine crash. The sequence was achieved using both the quarter-scale functional submarine model and smaller scale models which were shot dry-for-wet and not submerged. Designed to withstand pressure exerted by up to 50 feet of water as well as effects used in action sequences, it is cast from fiberglass with an acrylic dome and foam, wiring, and various tube frame copper components filling the interior. A radio-controlled Dr. Brigman model miniature sits in the cockpit.

During production, five kilowatts of working lights wired to and powered by internal nicad batteries were attached to the hull and frame. The lights have since been converted to modern LEDs. Due to its size and shape, the batteries allowed Conti's team to generate about 10 minutes of movement at full throttle, using re-engineered electric trolling motors to produce the required thrust.

This model is hand-marked "Port 1" and "P 2" in black marker and intentionally distressed by production to appear well-used underwater. It exhibits discoloration, a buildup of grime, chipping, and notable adhesive residue, as well as missing components and fragility to the foam from age and exposure. Dimensions: 56" x 23" x 26" (142.25 cm x 58.5 cm x 66 cm)

Contains electronics; see electronics notice in the Buyer's Guide.

Special shipping required; see notice in the Buyer's Guide.

**Estimate: \$75,000 - 150,000**

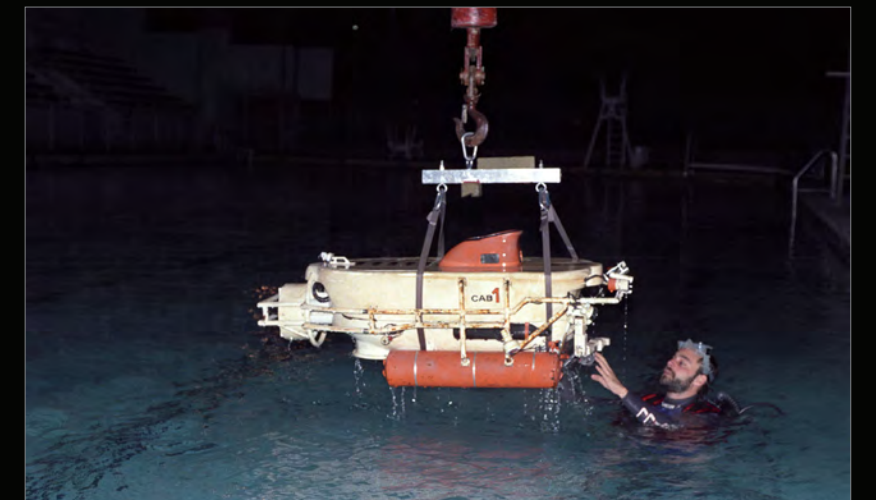



**5**  
**Lindsey's (Mary Elizabeth Mastrantonio) Costume**  
**The Abyss (1989)**

Lindsey's (Mary Elizabeth Mastrantonio) costume from James Cameron's sci-fi film The Abyss. Lindsey's costume became progressively more distressed as she and Deep Core's crew assisted the trigger-happy SEAL team sent on a recovery mission for a sunken nuclear submarine and, in the process, discovered some mysterious beings in the deep water.

This costume comprises a cream tank top (size Medium 38 - 40) featuring "Lindsey" handwritten inside the back and a tear down the front from when Bud (Ed Harris) tried to resuscitate her after she entered deep hypothermia; a blue denim shirt (size M) featuring a tear and stage blood on the left sleeve, an injury made when the rig was damaged and flooded during a storm; a red quilted body warmer (size M) and gray denim jeans (size 8 Med). The costume exhibits intentionally added dirt and distressing to reflect the increased damage and wear Lindsey encountered throughout the film.

**Estimate: \$6,000 - 12,000**

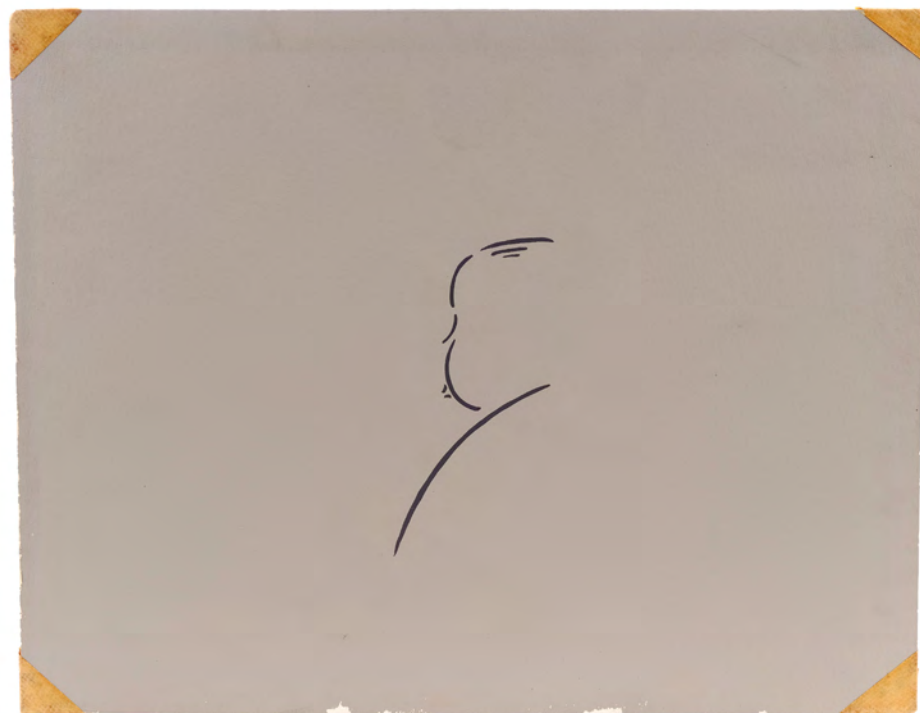

**6**  
**Hand-Drawn Opening Title Art**  
**Silhouette**  
**Alfred Hitchcock Presents**  
**(1955-1965)**

A hand-drawn opening title art silhouette from the anthology series Alfred Hitchcock Presents. The opening title of the show featured Hitchcock's shadow stepping into frame over his iconic, minimalist, nine-stroke silhouette.

Originally obtained from the famous Pacific Title and Art Studio, this piece consists of Hitchcock's silhouette hand-drawn in black against a gray background on illustration board. It exhibits tape in the corners, edge wear, and some staining on the back. Dimensions: 14" x 11" x 0.25" (35.75 cm x 28 cm x 0.75 cm)

Sold without copyright; see notice in the Buyer's Guide.

**Estimate: \$5,000 - 10,000**



**7**  
**Thing Hand Stand-In**  
**The Addams Family (1991)**

A Thing hand stand-in from Barry Sonnenfeld's The Addams Family. Thing was a friend and helper to the Addams family for many years, and also supported the family.

From the collection of Doug Beswick, this lot consists of the stand-in used for planning shots that incorporated other VFX elements, made of pink-painted latex foam with a metal base textured to resemble skin and is positioned in Thing's resting pose. This lot exhibits cracking material along the thumb, chipping paint along the fingers, and squished foam from its resting position. Dimensions: 8.5" x 5.5" x 3" (21.75 cm x 14 cm x 7.75 cm)

**Estimate: \$2,000 - 4,000**



**8**  
**Kane's (John Hurt) Nostromo Shirt**  
**Alien (1979)**

Kane's (John Hurt) Nostromo shirt from Ridley Scott's sci-fi horror Alien. Kane wore his shirt after being revived from hypersleep aboard the USCC Nostromo.

This beige linen gold-color textured metal button-down shirt features a blue embroidered Weyland-Yutani wings patch on the left breast, front pockets with hook-and-loop closures, and white nylon loops above the right breast pocket for pens. The affixed Weyland-Yutani wings differ from the silver embroidery of the on-screen version. The production-made blue embroidered version, used on Nostromo officer jackets, was believed to be added during or after production. Further, the Nostromo shoulder patch has been removed from the right sleeve, exposing glue remnants from prior attachment. This shirt is marked "JH D" along the back collar. This lot exhibits staining, loose threads, and discoloration throughout.

**Estimate: \$10,000 - 20,000**





**9**  
**Nostromo Detonator Sequence Bolt**  
**Alien (1979)**

A Nostromo detonator sequence bolt from Ridley Scott's sci-fi horror film Alien. Ripley (Sigourney Weaver) used four bolts to activate the self-destruct sequence on the Nostromo as a last-resort to destroy the alien onboard.

This lot consists of one metal and acrylic bolt manufactured in the SFX Workshop at Bray Studios. It features a textured top, three engraved bands, a hexagon-shaped protrusion, spiral grooves, and a smooth clear conical tip on a gold-color base. Also included is a Letter of Authenticity signed by Bill Pearson. This lot exhibits scratches in the metal's finish, as well as pitting and discoloration on the spiral grooves. Dimensions: 7" x 1.25" x 1.25" (18 cm x 3.25 cm x 3.25 cm)

**Estimate: \$12,000 - 24,000**



**10**  
**Ripley's (Sigourney Weaver) Watch**  
**Alien (1979)**

Ripley's (Sigourney Weaver) watch from Ridley Scott's sci-fi horror film Alien. Ripley wore her watch throughout the film.

This lot consists of a black Casio F-100 watch preserved in a custom acrylic display. The watch's face features categories for "month," "date," and "day," as well as for "M," "S," "1/100," "H," "M," "S," and a set of four buttons, two red and two black. The acrylic display features four panes, three of clear acrylic and the bottom fourth one is made of a white frosted acrylic. Six screws keep the display together. This lot exhibits a significantly deteriorated wristband. Dimensions: 8" x 4.25" x 1" (20.5 cm x 11 cm x 2.75 cm)

Contains electronics; see electronics notice in the Buyer's Guide.

**Estimate: \$7,000 - 14,000**



**11**  
**Ash's (Ian Holm) Production-Made Nostromo Crew**  
**Shirt and Patch with Promotional Pin**  
**Alien (1979)**

Ash's (Ian Holm) production-made Nostromo crew shirt and patch with promotional pin from Ridley Scott's sci-fi horror film Alien. Ash wore his shirt while aboard the Nostromo, and like other crew members, wore a patch on the shoulder.

This lot consists of a production-made shirt, a Nostromo shoulder patch, and a promotional science office pin. Made of metal, this pin is circular in shape, and has been finished in gold-color with a blue geometric design, similar to the one Ash wore on his uniform. The shirt features "Ian Holm 15" hand-marked in black ink on the interior Bermans and Nathans tag. Also included are letters of authenticity from Roger Nichols and Pat Lowry. This lot exhibits faint discoloration, snagged threads, and scratches in the pin's finish.

**Estimate: \$7,000 - 14,000**





**12**  
USCM Headset  
**Aliens (1986)**

A USCM headset from James Cameron's sci-fi sequel Aliens. United States Colonial Marines wore their standard-issue headsets to keep in contact when they investigated the disappearance of the colonists on LV-426.

This two-piece headset consists of a connected mic and earphone and an adjustable headband. Made of metal and plastic, it was painted a matte brown-color and features a "Minilite" logo on the ear piece. The ear and mic pieces feature a metal clip to attach to the headband, along with a piece of cut tubing filled with braided wires. The headset also has foam padding and a small piece of foam over the mic. This headset exhibits chipped and cracked paint, as well as notable discoloration on the paint.

**Estimate: \$6,000 - 12,000**

**13**  
USCM M314 Motion Tracker Screen  
**Aliens (1986)**

A USCM M314 Motion Tracker Screen from James Cameron's sci-fi sequel Aliens. Ripley (Sigourney Weaver) and the team of Colonial Marines used their M314 motion tracker to locate and track the deadly aliens on the human colony.

This lot consists of one gray and black plastic tracker screen painted the "Aliens Brown" color like other trackers, this tracker features an acrylic screen, two static switches and two small LED lights at the bottom, as well as a reflective lens behind the screen. This lot exhibits cracked plastic, missing parts, lifted tape, and notable adhesive residue. Dimensions: 3" x 3.5" x 2.5" (7.75 cm x 9 cm x 6.75 cm)

Contains electronics; see electronics notice in the Buyer's Guide.

**Estimate: \$4,000 - 8,000**



**14**  
Bug Stomper Dropship  
Ejection Seat Handle  
**Aliens (1986)**

A Bug Stomper dropship ejection seat handle from James Cameron's sci-fi action sequel Aliens. A xenomorph stowaway on the Bug Stomper killed Corporal Ferro (Colette Hiller) before she could pull the dropship's ejection seat handle.

This static handle consists of a metal pipe body painted silver-color and ruby-color with a rubber cord inserted through its top hoop. The cord is wrapped with yellow emergency tape. The handle exhibits flaking paint and some rusting, and the tape is peeling on both ends from production use and age. Dimensions: 13.5" x 6" x 2" (34.5 cm x 15.25 cm x 5 cm)

**Estimate: \$4,000 - 8,000**



**15**  
Terry English-Made Hudson  
USCM Armor Costume Replica  
**Aliens (1986)**

A Terry English-Made Hudson USCM armor costume replica from James Cameron's sci-fi action sequel Aliens. English designed and made the armor for the United States Colonial Marines for production. This aluminum armor consists of a helmet with an attached camera, earpiece, and infrared sight; chest and back armor linked together by black web belting with "Hudson" stenciled on the chest, "Louise" hand-painted on the left breast, and a hand-painted skull and crossbones with the words "or Glory" painted beneath; a USCM camouflage canvas shirt with custom patches, matching camouflage canvas trousers; vinyl-padded aluminum ab plates; a canvas pouch and web belt and holster with plastic buckles, a leather knife sheath, inert shotgun shell ammo; greaves; leather boots; a resin and metal shoulder lamp; a pair of clear acrylic dog tags on silver ball chain; and a pair of hand tools including a resin and metal hand welder with an acrylic screen and components. The armor is hand-painted in green military camouflage. This lot exhibits some scratches and scuffing. Contains electronics; see electronics notice in the Buyer's Guide.

**Estimate: \$3,000 - 6,000**

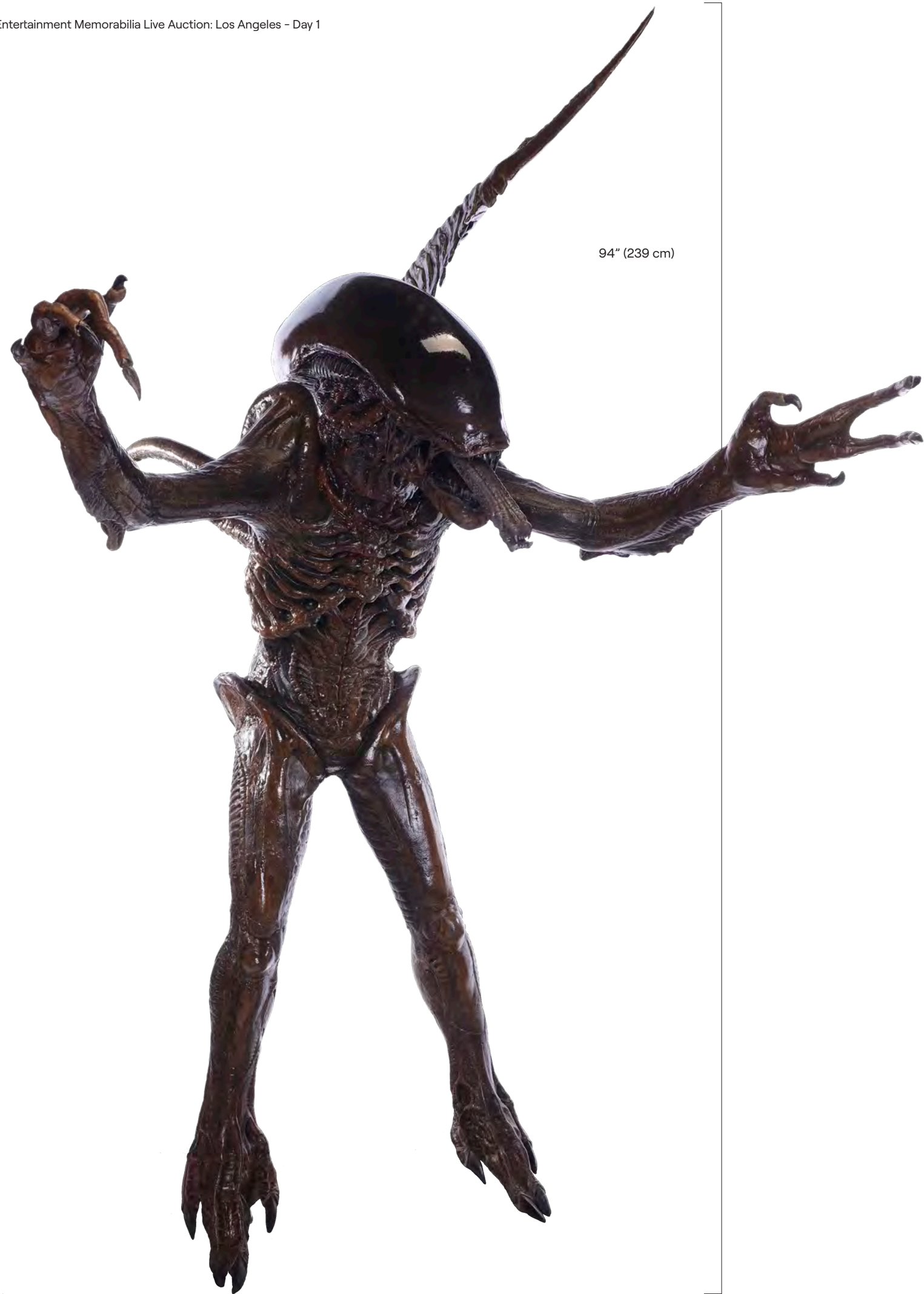

94" (239 cm)



**16**  
**Xenomorph Costume on Display**  
**Alien Resurrection (1997)**

A display of a xenomorph costume from Jean-Pierre Jeunet's horror-sci-fi film *Alien Resurrection*. Ellen Ripley (Sigourney Weaver) was revived as the clone Ripley 8 and soon found herself once again face-to-face with the deadly xenomorphs.

This costume comes from the film's Academy Award®-winning special effects group, Amalgamated Dynamics, Inc. (ADI), where it was displayed as an archive piece. This lot consists of a gloss brown paint finish foam alien zipper costume that was mounted onto Tom Woodruff's lead alien bodyform following production. The head of the costume features a plexiglass see-through dome with two sets of mounts and cables on either side of the head to control lip snarl and jaw movements. The tail is attached by Allen bolts and can be removed. This display comes positioned in attack mode. It is mounted by Allen bolts to a wooden custom-made base on wheels and can be removed. This lot exhibits restoration, completed by restoration artist Joe Petro, and minor cracking material. Dimensions: 50" x 60" x 94" (127 cm x 152.5 cm x 239 cm)

Contains electronics; see electronics notice in the Buyer's Guide.

Contains mechanical components; see notice in the Buyer's Guide.

Special shipping required; see notice in the Buyer's Guide.

**Estimate: \$40,000 - 80,000**





90" (228.75 cm)

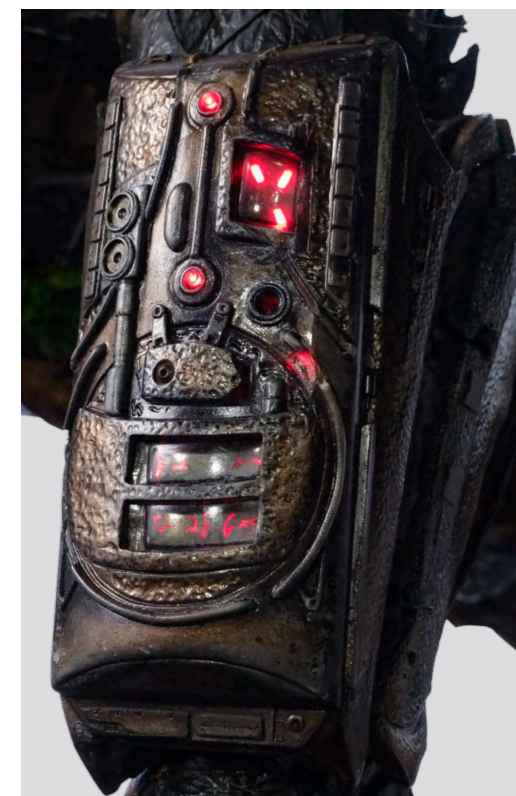

**17**  
**Wolf Predator (Ian Whyte) Costume on Display**  
**AVPR: Aliens Vs. Predator-Requiem (2007)**

A display of a Wolf Predator (Ian Whyte) costume from The Brothers Strause's sci-fi action sequel *Aliens vs. Predator: Requiem*. The hunter known as Wolf (Ian Whyte) traveled to Gunnison, Colorado to dispatch the murderous Predalien born at the conclusion of Paul W.S. Anderson's *Alien vs. Predator*.

This costume was created by Academy Award®-winning special effects group Amalgamated Dynamics, Inc. (ADI). It includes a highly detailed mottled green, yellow, and brown foam latex skin bodysuit with Wolf's personalized netting; a head cowl with black foam rubber dreadlocks; airbrushed silver-color foam rubber body armor over the left shoulder, breast, knees and calves; a beaded necklace with resin creature skulls; mounted back armor that conceals the mechanics for the animatronic shoulder cannons originally operated by cable and radio controls with wiring leading up to them; resin and foam rubber wrist gauntlets, the right one features two resin blades sticking out with a small metal rod adhered between them for stability and the left one features Yautja alphabetic characters that illuminate when an internal button is pressed; a brown leather loincloth with a foam rubber jawbone buckle and armor piece, hidden black plastic side buckles; a resin shuriken; and foam rubber feet. This costume has been purposely distressed by production. Following production, it was mounted onto a black fiberglass body cast of performer Ian Whyte that has been secured to a gray-painted wheeled wooden display base. The foam latex, rubber, and resin exhibits some scuffing and cracking from use and age, the left gauntlet has one empty light hole, the lower back has a hole where the Xenomorph tail was thrust through, and the current functionality of the shoulder cannons remains untested. Dimensions: (displayed) 53" x 55" x 90" (134.75 cm x 139.75 cm x 228.75 cm)

Special shipping required; see notice in the Buyer's Guide.

Contains electronic components; see notice in the Buyer's Guide.

**Estimate: \$35,000 - 70,000**



**18**  
**Xenomorph Warrior Costume on Display**  
**AVP: Alien Vs. Predator (2004)**

A display of a xenomorph warrior costume from Paul W.S. Anderson's sci-fi action film AVP: Alien vs. Predator. Yautja Predators farmed xenomorphs on Earth to be hunted as part of their rite of passage.

This costume, designed by Academy Award-winning special effects group Amalgamated Dynamics, Inc. (ADI), consists of a foam-latex domed headpiece hand-painted black and gray with a matching foam-latex bodysuit. The bodysuit features a nylon lining secured with a zip closure; resin fingernails; snap-button joints on the arm and leg pieces; four dorsal tubes molded around exposed copper wire; and a long screw-on airbrushed latex tail molded around a flexible metal-pipe core. Production intentionally distressed this costume to appear battle-damaged such as the yellow guts, and holes present on the costume.

Following production, this costume was permanently mounted to an airbrushed silver-color wooden base for display purposes. It exhibits wear at the major joints from production, as well as deterioration, exposed foam, and other signs of wear to the latex throughout. Dimensions: 36" x 33" x 98" (91.5 cm x 84 cm x 249 cm) Special shipping required; see notice in the Buyer's Guide.

**Estimate: \$10,000 - 20,000**



**19**  
**Hero Animatronic Facehugger Δ**  
**AVP: Alien Vs. Predator (2004)**

A hero animatronic Facehugger puppet from Paul W.S. Anderson's sci-fi action film AVP: Alien vs. Predator. Facehuggers latched onto humans and Predators during the Predators' Antarctic xenomorph hunt.

This intricate foam latex puppet was created by Academy Award®-winning special effects group Amalgamated Dynamics, Inc. (ADI) for shots of the Facehuggers latching. It is hand-painted brown, green, and pink, and molded around an internal mechanical armature with servos extending from the rear to an electronic control box. The servos operate the legs when connected to electricity via a 5V power cable, though several cables were cut following production. The puppet exhibits splits in the foam, particularly around the joints. Dimensions: 16" x 16" x 17" (40.75 cm x 40.75 cm x 43.25 cm)

Contains mechanical and electronic components; see notice in the Buyer's Guide.

**Estimate: \$8,000 - 16,000**



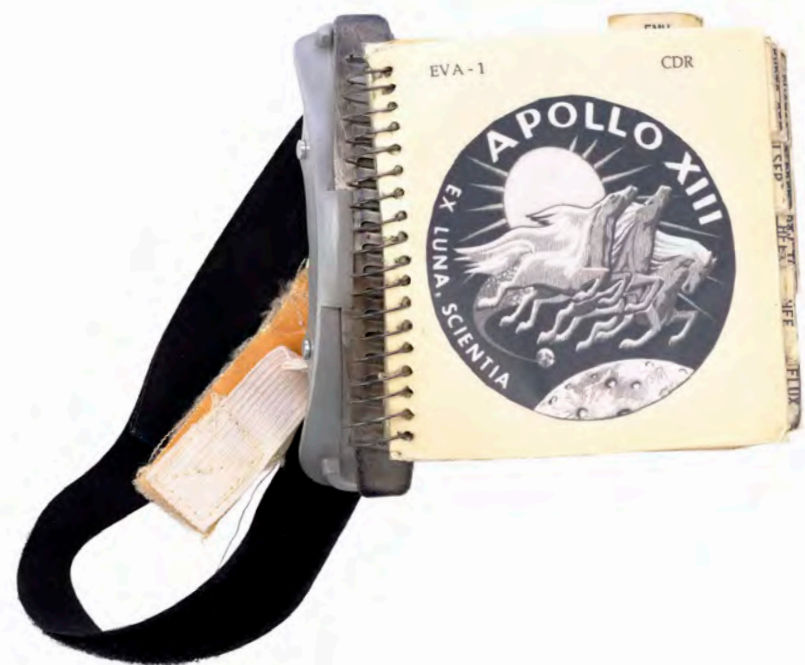

**20**  
**Jim Lovell's (Tom Hanks) Lunar Surface Cuff Checklist**  
**Apollo 13 (1995)**

Jim Lovell's (Tom Hanks) lunar surface cuff checklist from Ron Howard's historical-drama film Apollo 13. Lovell wore his cuff checklist when he daydreamed about landing on the moon.

This lot consists of a spiral-bound, laminated booklet featuring tables, diagrams, and notes; a metal brace that holds the booklet in place; and black-and-white nylon straps with fastening wrist strips. The inside cover features handwritten signatures by D.A. Bland Junior, R.V. Blevins, R.G. Zedekar, and Captain James Lovell, CDR. This lot exhibits loose thread on the white strap, discoloration and grime, and bleeding ink from the signatures.

**Estimate: \$3,000 - 6,000**



**22**  
**Production-Made "Clock Tower Struck By Lightning"**  
**Hill Valley Telegraph Newspaper Cover**  
**Back To The Future (1985)**

A production-made Hill Valley Telegraph newspaper cover headlined "Clock Tower Struck By Lightning" from the production of Robert Zemeckis' time travel adventure Back to the Future. The Hill Valley Preservation Society reprinted a Telegraph article on the clock tower in fliers they gave to Marty McFly (Michael J. Fox) and Jennifer (Claudia Wells) in the town square.

Created by Earl Hays Press for the production, this black-and-white newspaper cover numbered "Vol XVII, No. 32" features the subheader "Clock Stopped at 10:04" next to a picture of the clock tower. Unrelated filler text is printed throughout. The cover exhibits pinholes, fold lines, and discoloration from use and age. Dimensions: 13.5" x 22.75" (34.5 cm x 58 cm)

**Estimate: \$2,000 - 4,000**



**23**  
**Old Biff Tannen (Thomas F. Wilson) Puppet**  
**Back To The Future Part II (1989)**

An Old Biff Tannen (Thomas F. Wilson) puppet from Robert Zemeckis' sci-fi adventure sequel Back to the Future Part II. Old Biff stole the DeLorean from Marty McFly (Michael J. Fox).

Created by Industrial Light & Magic (ILM) for use in the DeLorean model miniature's interior during time travel sequences, this foam puppet is applied with gray synthetic hair and tape on its hands for handling the steering wheel. Its body is hand-painted with a brown jacket and striped pants, while its boots and bottom are partially unpainted, as only the upper body was seen onscreen. An electronic servo is fitted to the puppet's underside designed to operate the torso and head. This lot should be handled with caution as the foam exhibits cracking and the paint is flaking from age and production use. Dimensions: 5" x 5" x 11" (12.75 cm x 12.75 cm x 28 cm)

Contains electronics; see electronics notice in the Buyer's Guide.

**Estimate: \$5,000 - 10,000**



**21**  
**Pair of Light-Up Atlantean Soldier**  
**Marketing Display Statues**  
**Aquaman (2018)**

A pair of light-up Atlantean soldier marketing display statues from James Wan's action-fantasy film Aquaman. Statues of Atlantean soldiers in white and red suits were used for marketing the film's release.

This lot consists of two red and white iridescent painted resin Atlantean soldier display statues mounted on gray and gold-color painted resin bases. These statues are secured within a gray painted presswood case with an elevating top and doors with an Atlantean background and mirrors. The statues and case light up when powered with a cable and remote. This lot exhibits scuffs to the case's top. Dimensions: (statue) 22" x 15" x 11.5" (56 cm x 38.25 cm x 29.25 cm); (case) 33" x 23.5" x 31" (84 cm x 59.75 cm x 78.75 cm)

Contains electronics; see electronics notice in the Buyer's Guide.

**Estimate: \$4,000 - 8,000**





**24**  
**Pepsi Perfect Bottle**  
**Back To The Future Part II (1989)**

A Pepsi Perfect bottle from Robert Zemeckis' sci-fi sequel Back to the Future Part II. Marty McFly (Michael J. Fox) ordered a Pepsi Perfect when he pretended to be his own son at Cafe 80's in 2015.

This lot consists of a tall, transparent plastic bottle applied with a futuristic blue, red, and silver-color "Pepsi Perfect" logo decal on front and affixed with a glossy blue cap. The bottle comes mounted to a black display base inside a custom acrylic case. It is intentionally and extensively distressed with evaporated soda remnants on the interior from production use, and the cap exhibits sticky residue on top. Dimensions: 3.5" x 3.5" x 9.75" (9 cm x 9 cm x 25 cm)

**Estimate: \$10,000 - 20,000**

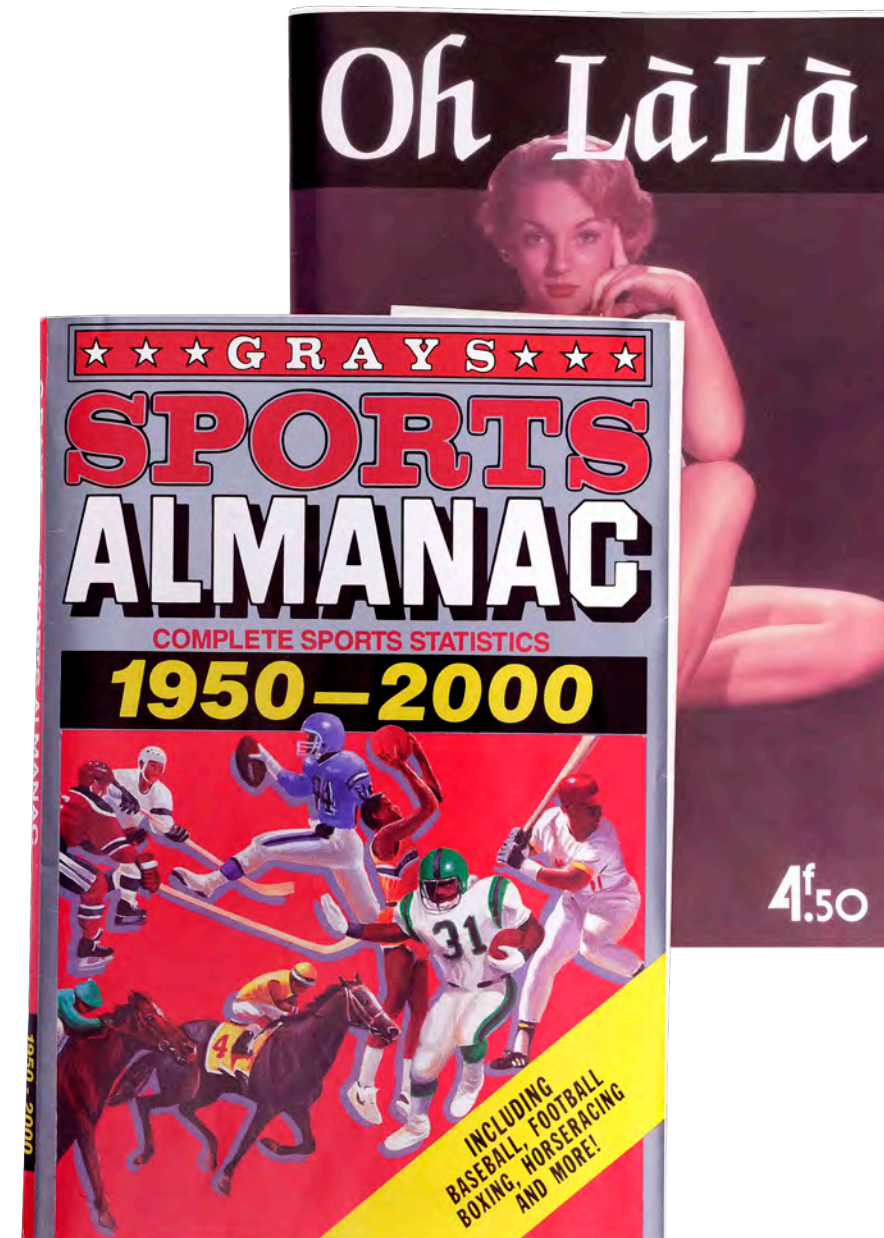

**25**  
**Grays Sports Almanac Cover**  
**with Oh La La Magazine**  
**Back To The Future Part II (1989)**

A Grays Sports Almanac cover with an Oh La La magazine from Robert Zemeckis' sci-fi sequel Back to the Future Part II. Marty McFly (Michael J. Fox) attempted to retrieve what he believed was Biff Tannen's (Thomas F. Wilson) sports almanac, but only recovered its dust jacket wrapped around a copy of Biff's favorite French nudie magazine.

This lot consists of a production-made glossy paper cover headlined "GRAYS SPORTS ALMANAC" with blank interior flaps applied over a glossy paper magazine with a color-printed "Oh La La" cover consisting of a stapled spine, and both black-and-white and color interior pages featuring French text and pin-up photographs. The flaps of the Sports Almanac are exceedingly rare and are a telltale sign that the cover was used to wrap around an Oh La La magazine. It exhibits creases from folding and edge wear from production. Dimensions: 9" x 6" x 0.25" (23 cm x 15.25 cm x 0.75 cm)

**Estimate: \$10,000 - 20,000**



**26**  
 Rafe "Data" Unger's  
 (Ricky Dean Logan) Wooden  
 Hoverboard  
**Back To The Future Part II (1989)**

Rafe "Data" Unger's (Ricky Dean Logan) wooden hoverboard from Robert Zemeckis' sci-fi adventure sequel *Back to the Future Part II*. Marty McFly (Michael J. Fox) was chased through the town square by Data and other members of Griff Tannen's (Thomas F. Wilson) gang on their hoverboards.

This hoverboard consists of a custom-made wooden deck painted green with green, red, orange, black, and beige flame decals, circuit board patterns, and the words "No Tech Knowhow." Yellow and green wooden details are screwed into the sides of the board, and a black disc with a red fastening strip foot strap is screwed into the top. Red fastening strip elements have been added to the flame design on the front. The hoverboard exhibits wear from use and age throughout, including some chipping, loosening of the foot strap disc, and four screws sticking out of the underside of the board where the hover pad mechanisms would have once been attached but are no longer present. The magnet fixture is also absent, however, the outline and screw holes for the mechanism are visible. Dimensions: 30" x 9" x 1.5" (76.25 cm x 23 cm x 4 cm)

**Estimate: \$20,000 - 40,000**



**27**  
 Leslie "Spike" O'Malley's  
 (Darlene Vogel) Lightweight  
 Hoverboard  
**Back To The Future Part II (1989)**

Leslie "Spike" O'Malley's (Darlene Vogel) lightweight hoverboard from Robert Zemeckis' sci-fi adventure sequel *Back to the Future Part II*. Marty McFly (Michael J. Fox) was chased through the town square by Spike and other members of Griff Tannen's (Thomas F. Wilson) gang on their hoverboards.

This hoverboard is made of lightweight rigid styrofoam painted black with gold-color speckling. It features neon-orange, brown, and burgundy decals applied to the top, and neon-yellow, green, and pink painted designs and words on the bottom. Affixed to the bottom are two black, burgundy, and silver-color vacuum-formed plastic hoverpads. The hoverboard is missing its footpad and exhibits signs of use and age, including some paint chipping and small punctures to the foam. Dimensions: 30" x 10" x 1.5" (76.25 cm x 25.5 cm x 4 cm)

**Estimate: \$20,000 - 40,000**





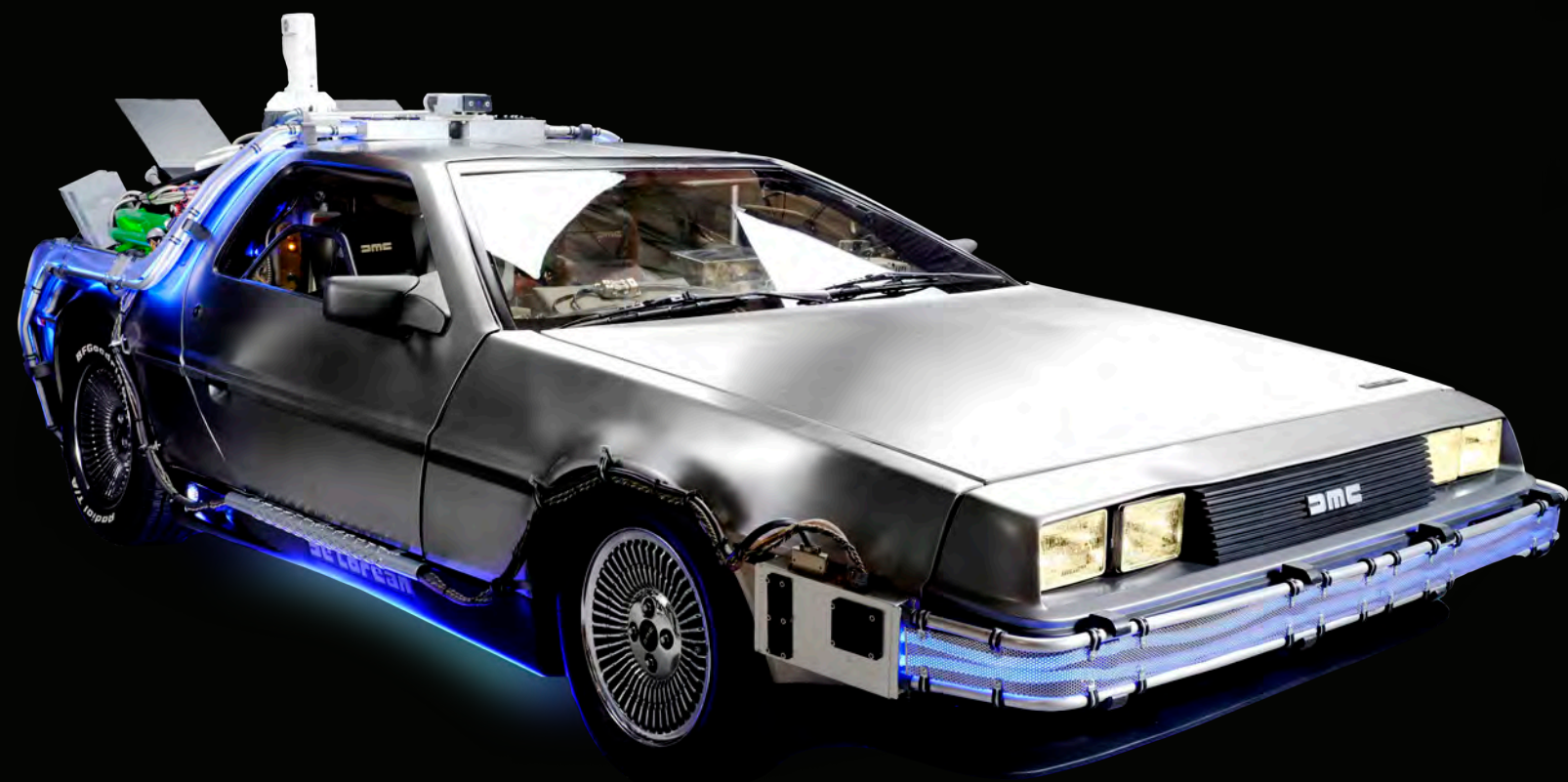

**28**  
**Light-Up Full-Size DeLorean Time Machine Replica**  
**Used at Official Universal Studios Promotional Events**  
**Back To The Future Trilogy (1985-1990)**

A light-up, full-size DeLorean time machine used at multiple promotional events at Universal Studios Hollywood. Doc Brown's (Christopher Lloyd) time-traveling DeLorean was the signature vehicle in Robert Zemeckis' Back to the Future trilogy, used throughout each film by Brown and Marty McFly (Michael J. Fox) as they scrambled to save history.

This ornately detailed, full-size 1981 DeLorean DMC-12 replica was constructed for a private collector in the late 1990s by DeLorean of California service manager Danny Botkin, who also helped restore the screen-used "A" DeLorean from Back to the Future. Universal hired this DeLorean from a private collection to use at Universal Studios Hollywood and Universal CityWalk events throughout the 2000s, including the 2007 "Countdown to the Final Flight" event held for Back to the Future: The Ride. The car was featured in the June 2007 Car & Driver magazine.

The exterior of the vehicle is installed with extensive custom-fabricated replica components matching those seen in the films, including a Mr. Fusion Home Energy Reactor, an "OUTATIME" license plate dated "AUG 86," a Flux Capacitor, and a medley of auxiliary lights and wires along the undercarriage and tailfins. It features a trapezoidal windshield with gullwing doors, Goodrich tires, and the signature stainless steel body panels associated with the brand. The frame has been powder coated to prevent rust. The lights illuminate via a key fob, while halogen lights inside the car vents operate via a switch on the interior.

The vehicle's two-seat interior is similarly overhauled with both operational and faux electronic components, including three adjustable time circuit boxes labeled "Destination Time," "Present Time," and "Last Time Departed," a Dayton electronics kit on the center console, and a keypad which operates phone sound effects adjacent to the wheel.

It is upholstered with gray corduroy and black leather with DeLorean Motor Company labels visible throughout the interior, including on a manufacturer's plaque on the driver's side dated "Aug. 81," on the floor rugs, and on QR code decals applied under each door. Numerous sound clips can be played via internal and external speakers. A Panasonic radio, a backup camera, and a three-battery system in the trunk designed to operate the time machine features and stereo are also installed. Also included are a Letter of Authenticity from Botkin confirming that this privately-owned DeLorean was hired for several official Universal Studios promotional events, a breakdown of the car's electrical systems and instruments, and color-printed photographs of Lloyd and Jay Leno with the vehicle.

This DeLorean is fully operational, registered, and insured with Vehicle Identification Number (VIN) SCEDT26T3BD002901 and a current mileage of 22,532. Due to its previous operation and exhibition, several of the replica components on the back exhibit loosening and minor staining, the interior upholstery exhibits minor grime and wear, and the right-side dash panel lights are not currently functional. As this is a functioning vehicle, legal transfer of title will need to take place before delivery can be arranged. Dimensions: 170" x 75" x 90" (432 cm x 190.5 cm x 229 cm)

- Contains electronic components; see notice in the Buyer's Guide.
- Contains mechanical components; see notice in the Buyer's Guide.
- Special shipping required; see notice in the Buyer's Guide.

**Estimate: \$150,000 - 300,000**

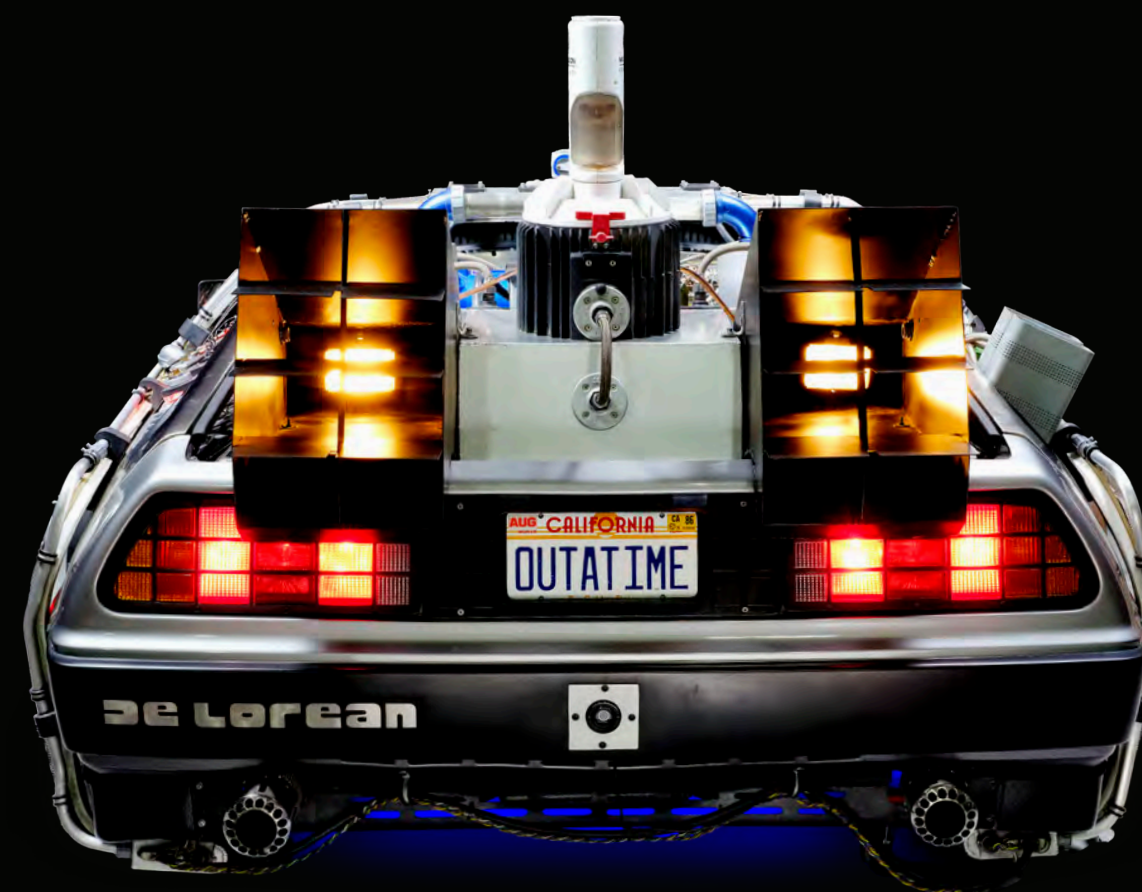
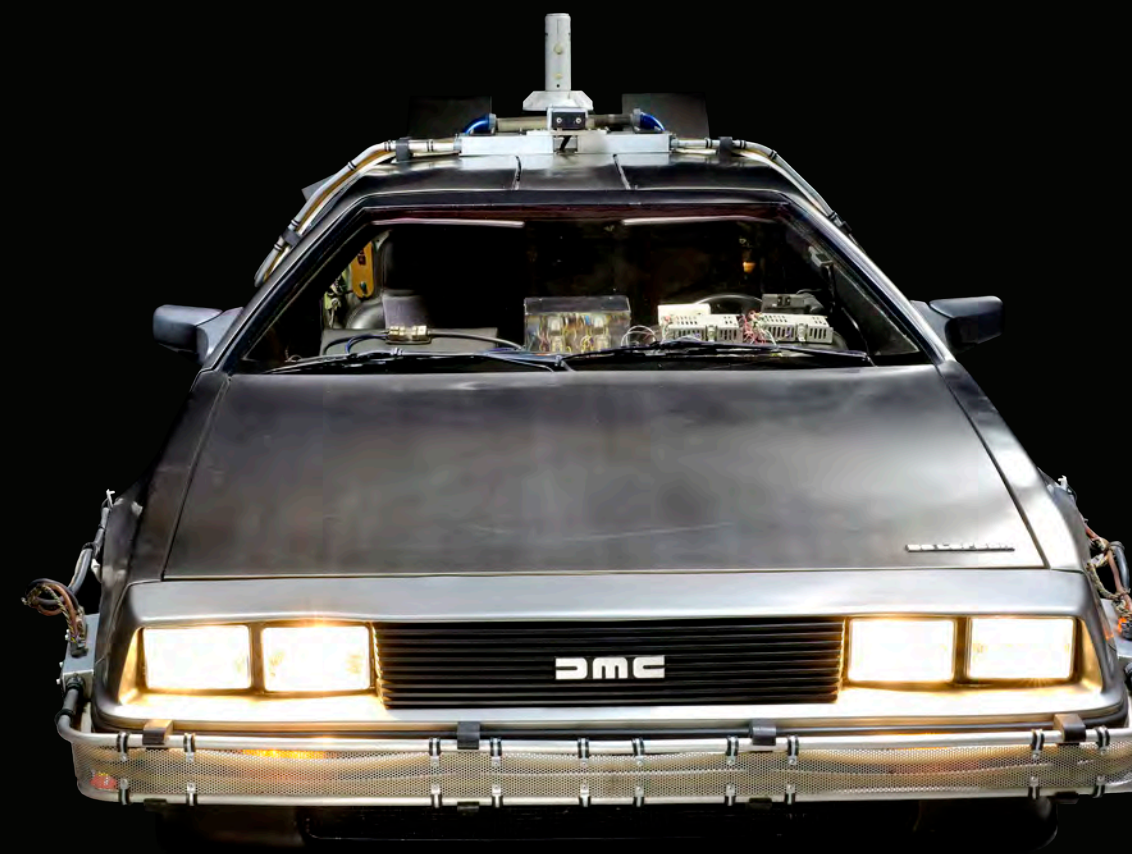

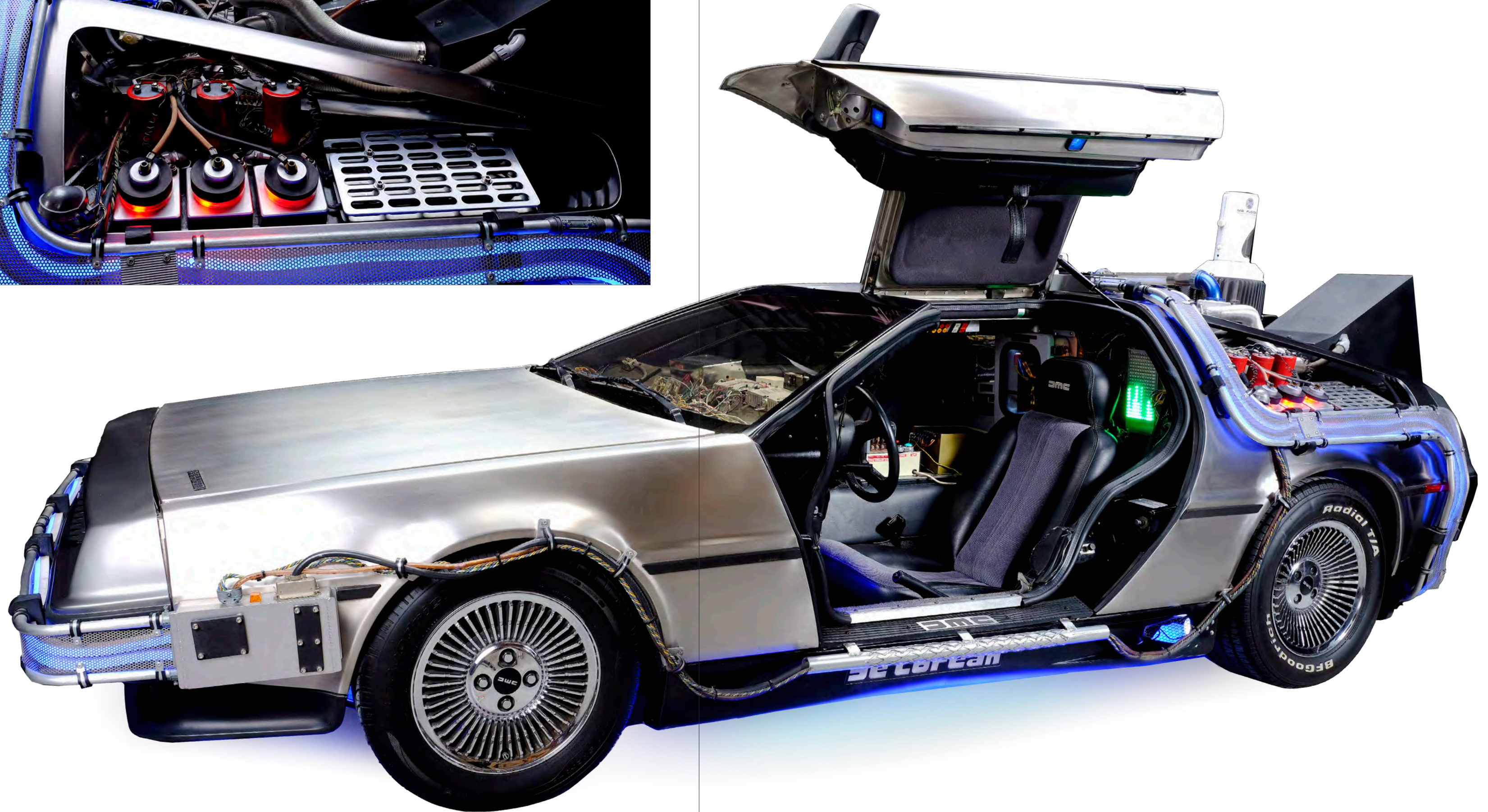
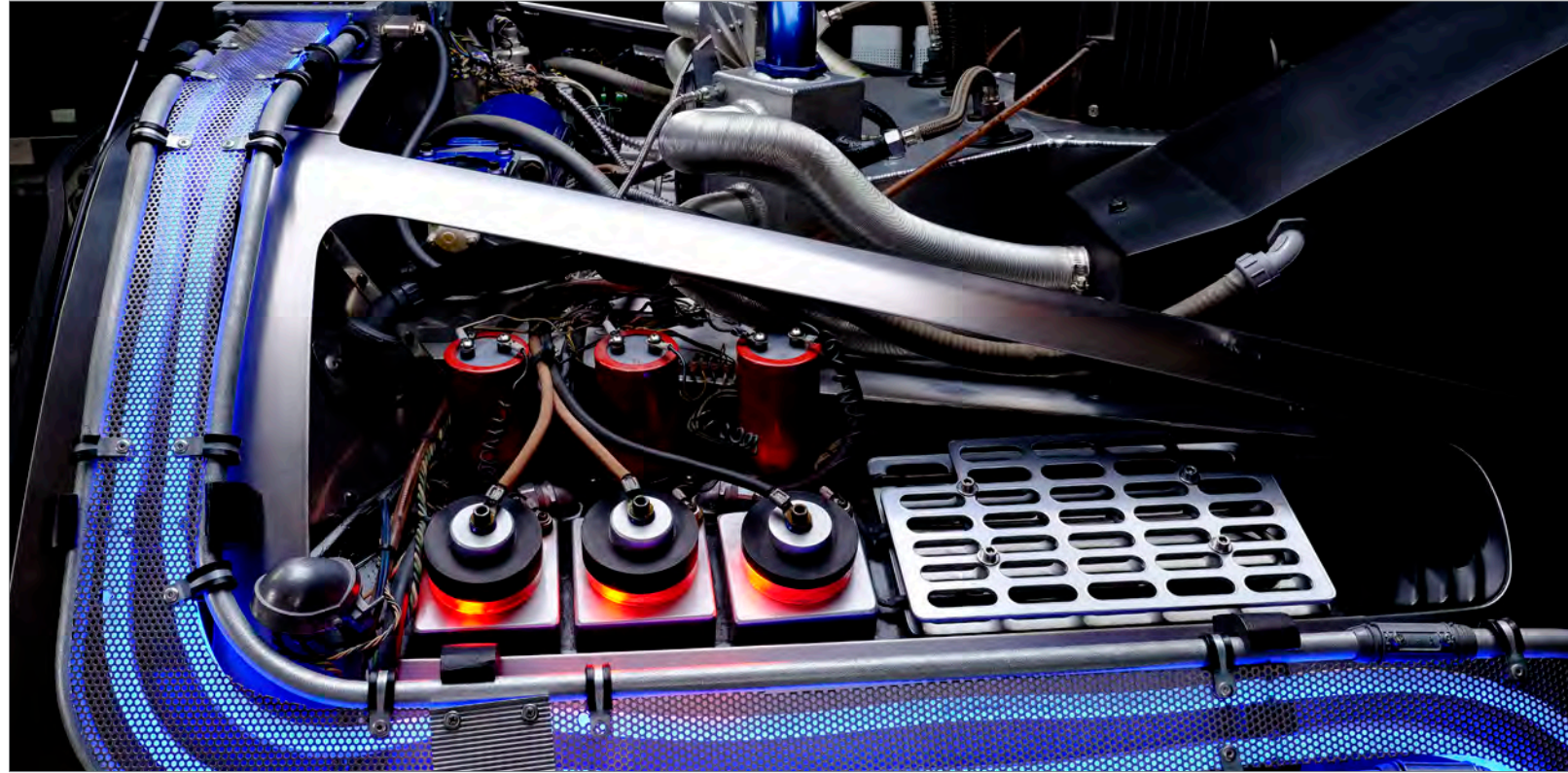

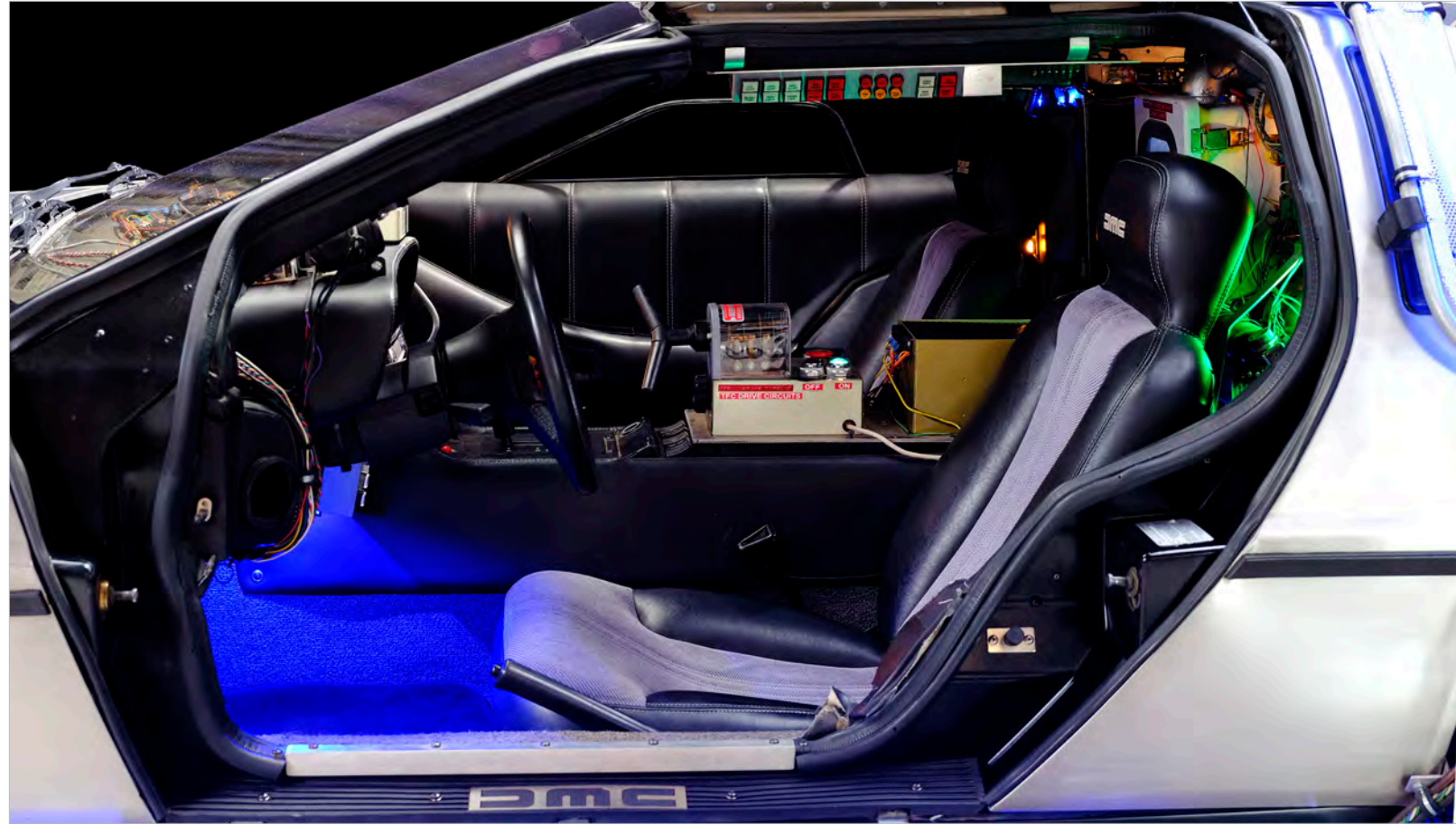

**29**  
**Batman's (Michael Keaton) Batsuit Costume**  
**Batman (1989)**

Batman's (Michael Keaton) batsuit costume from Tim Burton's action-adventure film *Batman*. Batman wore his costume as the masked vigilante of Gotham City throughout the film.

This costume consists of an original foam latex cowl with pointed ears, original foam latex torso armor and hip armor on a production-made undersuit (without zipper at the back) from *Batman* (1989) and a fabric-backed latex cape from the sequel *Batman Returns* (1992). The capes from the sequel were nearly identical to the original film's capes and are only distinguishable based on unseen interior details. The costume is mounted to a custom body form for display and completed with replica components including replica black leather gloves (size XL) with rubber plating and pointed fins; replica boots and boot armor; a replica yellow-painted rubber utility belt; and a replica resin chest emblem featuring a bat symbol with the three-point tail unique to the first film. The custom mannequin display features a lifecast of Keaton, and is mounted to a black wooden base. This costume had undergone sympathetic restoration to the foam latex. Specifically, the surface of the cowl has been patched, treated and sealed with a coating, and the ears have been restored. This lot exhibits notable fragile and flaking latex on the cape, wear to the body components, and shows sympathetic repairs to the cowl. It remains in stable condition though is also delicate.

Special shipping required; see notice in the Buyer's Guide.

**Estimate: \$40,000 - 80,000**

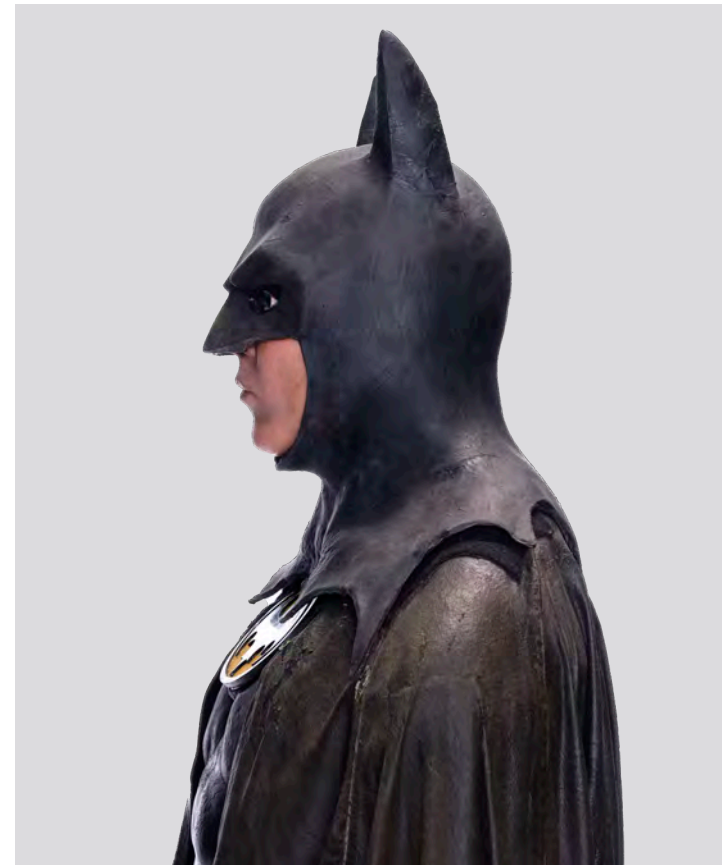

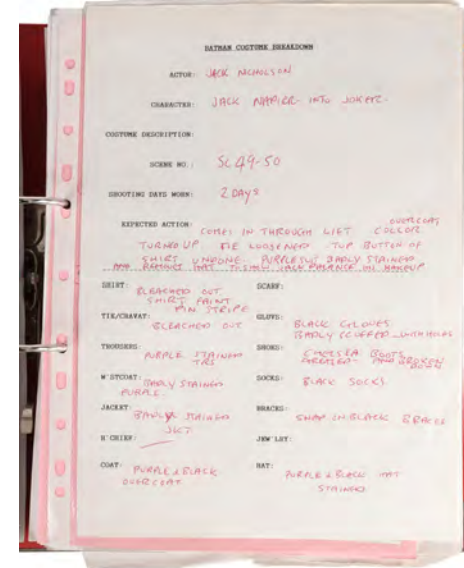
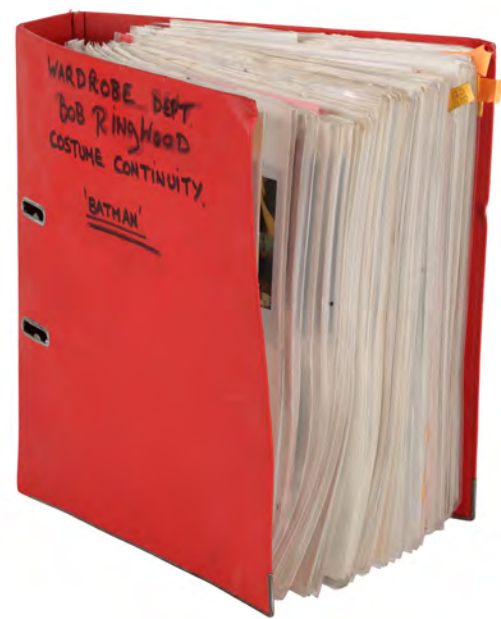

**30**  
**Costume Continuity Binder Featuring Archive of Main Cast Polaroids & Batman (1989)**

A costume continuity binder used by Academy Award®-nominated costume designer Bob Ringwood from the production of Tim Burton's superhero film *Batman*. The red binder contains a comprehensive insight into the various outfits worn by each character in every scene, and consists primarily of costume breakdown sheets, which display the actor, character name, scene number, shooting dates, and a brief costume description. The lower halves of the sheets feature a list of different garments with handwritten notes detailing aspects of the outfits.

A total of 283 Polaroid photographs are adhered to their corresponding pages, which show principal, supporting, and background cast members. The photos include *Batman* (Michael Keaton) in his iconic Batsuit, and *The Joker's* (Jack Nicholson) array of vibrant outfits. Separated revised script pages feature throughout and accompany their corresponding costume breakdown sheets.

The paperwork exhibits edge wear and dirt marks, and several pages have become stuck together over time. A few Polaroids are loose within the folder. Dimensions: 12.5" x 11.5" x 4.25" (31.5 cm x 29 cm x 11 cm)

Sold without copyright; see copyright notice in the Buyer's Guide.

**Estimate: \$8,000 - 16,000**



**31**  
**1990 Favorite Motion Picture People's Choice Award Batman (1989)**

A People's Choice Award for Favorite Motion Picture awarded to Tim Burton's superhero film *Batman*. Jack Nicholson and Michael Keaton accepted the honor on behalf of the production at the 16th annual ceremony held March 11, 1990.

This glass award is sculpted by Orrefors of Sweden with an image of hands clapping within a flame etched into the teardrop-shaped center and "The People's Choice Award 1990 BATMAN Favorite Motion Picture" etched into the square base. Four clear rubber covers are applied to the bottom. The award exhibits fingerprints and minor scratches throughout from handling. Dimensions: 5" x 4" x 14" (12.75 cm x 10.25 cm x 35.75 cm)

**Estimate: \$5,000 - 10,000**



**32**  
**Screen-Matched Wayne Manor Bat-Signal Reflector Batman Returns (1992)**

A screen-matched Wayne Manor bat-signal reflector from Tim Burton's superhero sequel *Batman Returns*. The reflector is one of two fixed to Wayne Manor that reflected the Bat-signal into Bruce Wayne's (Michael Keaton) home to alert him when he was being called. Paint on this piece screen-matches it to when reflectors alerted Wayne that Gotham was under attack by the Red Triangle gang.

This model consists of a foam base painted to resemble carved stone and an intricate metal top with a series of cord pulleys used to move around the tiled mirror plate at its center mounted to a rod. Also included is a foam box with a wired LED light with no current power source. This lot was sympathetically restored after production and exhibits discoloration, a broken mirror tile, and flaking paint and foam. Dimensions: 20" x 15" x 54" (51 cm x 38 cm x 137.25 cm)

Contains electronics; see electronics notice in the Buyer's Guide.

**Estimate: \$8,000 - 16,000**

**33**

**Batman's (Michael Keaton) Batsuit Costume  
Batman Returns (1992)**

Batman's (Michael Keaton) batsuit costume from Tim Burton's superhero sequel *Batman Returns*. Batman wore his iconic Batsuit throughout the film as he battled with the Penguin (Danny DeVito) and Catwoman (Michelle Pfeiffer).

While the suit for Tim Burton's original *Batman* film featured body armor with a muscular look, the second iteration of the Batsuit featured a more industrial armored form. It was sculpted by Steve Wang and Jose Fernandez from design illustrations by Bob Ringwood.

This Batsuit has been mounted to a custom body form for display, featuring a Michael Keaton lifecast. The costume consists of an original foam latex cowl; an original black latex cape with a fabric lining; and an original foam rubber bodysuit with attached shoulder and upper arm armor, and a set of hip armor. The yellow and black cast resin bat chest emblem is a replica, as are the leather gloves, resin belt, lower leg foam armor, boots, and foam boot covers, which were added to complete the display. The latex cape on the suit is a particularly nice example and remains soft and supple. This suit's cowl has had sympathetic restoration to treat surface cracking and to patch cuts in the back where it was removed from a display head or actor previously. The body armor components have also had minor restoration and stabilization.

Special shipping required; see notice in the Buyer's Guide.

**Estimate: \$60,000 - 120,000**





**34**  
**Selina Kyle's (Michelle Pfeiffer) Catwoman Costume**  
**with Screen-Matched Corset**  
**Batman Returns (1992)**

Selina Kyle's (Michelle Pfeiffer) Catwoman costume with a screen-matched corset from Tim Burton's superhero sequel *Batman Returns*. Selina donned her signature Catwoman costume after Max Shreck (Christopher Walken) fired her and threw her out a window. This corset's distinctive front left side lower stitches screen-match to the scene where Batman (Michael Keaton) faced off against Selina at the Gotham Zoo's Arctic exhibit.

Selina's costume underwent three stages of distressing by production to reflect her transformation into Catwoman. This costume consists of a black- and white-painted rubber "stage 2" cowl with a red dot used to identify hero cowls applied to the interior and an aluminum strip based on painters' respiratory masks and custom-sized for Pfeiffer inserted along the bridge of the nosepiece; a black silicone elastomeric zip-up "stage 1" bodysuit with white thread stitching; a black rubber-coated green canvas corset marked "Stg 3" and "Michelle Pfeiffer"; a black leatherette glove; matching black leatherette knee-high DiFabbrizio stunt boots marked "Michelle" with laces labeled "too short" and breakaway rubber heels likely used for fight scenes; black rubber knee pads and elbow pads; black neoprene ankle braces with a handwritten paper template; black nylon socks; additional prototype rubber heels with fastening strips; and two production tags.

Production commissioned a total of 36 cowls from costume sculptor Jose Fernandez, nine for each stage of the cowl's distress. Nearly all were destroyed during production. The tattered "Stage 2" cowl in this lot, seen when Catwoman and the Penguin (Danny DeVito) agreed to team up against Batman, was restored by Fernandez circa 2017 and mounted to a life cast he sculpted of Pfeiffer to stabilize and preserve the foam. Also included is a Certificate of Authenticity from Fernandez based on his review and authentication of the costume.

The cowl and corset are intentionally distressed by production to appear tattered in different stages, the prototype heels are brittle, and the bodysuit exhibits cracking from age, with fragile material around the ankles and arms making it unlikely to be on a mannequin again.

**Estimate: \$20,000 - 40,000**

49.5" (125.75 cm)



**35**  
**Hand-Painted Bill Mather Bat Cave Matte Painting**  
**Batman Returns (1992)**

A Bat Cave matte painting hand-painted by Bill Mather for Tim Burton's superhero sequel *Batman Returns*. This large matte painting of the Bat Cave with notable outcroppings, the lower of which features Bruce Wayne's computer station and the upper of which feature darkened areas for Bruce to repair the car while Alfred (Michael Gough) approaches in composited live-action shots, is rendered in mixed media on glass and hand-marked "BM 71" in the upper right corner. Several letters in the marking are illegible due to fading, and the painting exhibits chipping and smudging. Dimensions: 49.5" x 61" x 1" (125.75 cm x 155 cm x 2.5 cm)

Sold without copyright; see notice in the Buyer's Guide.

Special shipping required; see notice in the Buyer's Guide.

**Estimate: \$8,000 - 16,000**

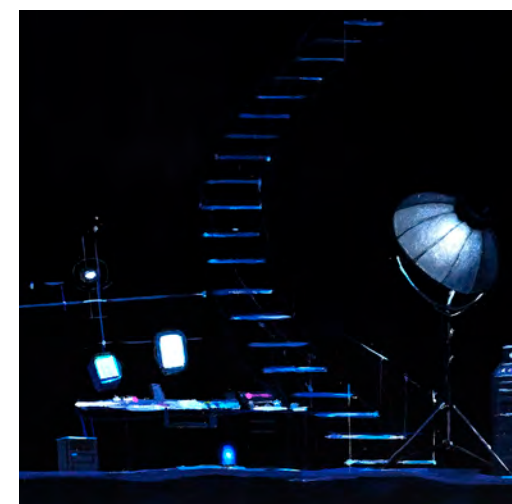



**36**  
**Hand-Painted Brian Flora**  
**Gotham City Building Matte Painting**  
**Batman Returns (1992)**

A Gotham City building matte painting hand-painted by Brian Flora for Tim Burton's superhero sequel *Batman Returns*. Buildings loomed over Gotham Plaza during the tree lighting ceremony while the Penguin (Danny DeVito) watched from the sewers.

This lot consists of one oversize matte painting on a framed glass panel. It features a hand-painted image of a skyscraper front with a wall of windows and art deco-inspired buttresses, with a darkened Christmas tree-shaped space in front. It also features a hand-marked "BM-10" in the corner. This lot exhibits chipped paint, smudges, and lifted tape. Dimensions: 49.5" x 61" x 1" (125.75 cm x 155 cm x 2.5 cm)

Sold without copyright; see notice in the Buyer's Guide.

Special shipping required; see notice in the Buyer's Guide.

**Estimate: \$4,000 - 8,000**



6' (1.8m)

**38**  
**Batskiboat Model Miniature**  
**Batman Returns (1992)**

A Batskiboat model miniature from Tim Burton's superhero sequel *Batman Returns*. Batman (Michael Keaton) took to the sewers of Gotham City in his Batskiboat to track down Oswald Cobblepot (Danny DeVito). This miniature was built for a specific shot where the boat launched off the sewer system wall and into the water, and was created by the visual effects team at 4Ward Productions, who received an Academy Award® nomination for their work on the film. Only the upper portion of the model was needed, so it was designed as a half-piece, with incomplete details on the bottom portion.

This model has a fiberglass shell reinforced with dense foam and plywood supports. It is painted gloss black, and is split into three segments: a domed front piece; a hull with one scalloped, wing-shaped hydrofoil on each side; and a back piece with a scalloped rear. It exhibits some wear from age and handling, including dirt stains in between the segments, cracking to the foam, and scuffs and paint chipping throughout. Dimensions: 72" x 42" x 9" (183 cm x 106.75 cm x 23 cm)

Special shipping required; see notice in the Buyer's Guide.

**Estimate: \$5,000 - 10,000**

**39**  
**Two-Face's (Tommy Lee Jones) Costume**  
**Batman Forever (1995)**

Two-Face's (Tommy Lee Jones) costume from Joel Schumacher's superhero sequel *Batman Forever*. Two-Face wore his costume when he shot his cannon at Batman (Val Kilmer) after escaping beneath the streets of Gotham.

This costume consists of a black polyester suit jacket half covered in bright pink and purple paint splatters marked "3" in the interior right breast pocket; matching paint splatter trousers marked "TLJ #1"; a black polyester cummerbund with half featuring silver-color thread embroidered skulls; a matching black polyester skulls bowtie; a half-white, half-black with silver-color motif long-sleeve, button-down shirt; and a metal lapel pin with faux razor blade skulls arranged as a flower with leaves and wires to resemble thorns. This costume comes mounted to a black velvet mannequin. It exhibits tape residue to the bowtie backing.

**Estimate: \$12,000 - 24,000**



140" (355.75 cm)

**37**  
**Large Screen-Matched Hand-Painted**  
**Oswald Cobblepot (Danny DeVito)**  
**Campaign Banner**  
**Batman Returns (1992)**

A large screen-matched and hand-painted Oswald Cobblepot (Danny DeVito) campaign banner from Tim Burton's superhero sequel *Batman Returns*. Stains on this banner screen-match it to the scene where Cobblepot was pelted with vegetables by an angry Gotham City crowd after *Batman* (Michael Keaton) hijacked his microphone feed mid-speech. Three large campaign banners hung in the background of this scene, with this particular banner being seen in the center.

This canvas banner is hand-painted "Oswald Cobblepot for Mayor" in yellow and red text beneath a multicolor caricature of Cobblepot holding his signature umbrella amid the Gotham City skyline. It exhibits creasing from being rolled, scuffing to the paint, and streaking stains from where the crowd's vegetables hit during production. Dimensions: 65" x 140" (165.25 cm x 355.75 cm)

Special shipping required; see notice in the Buyer's Guide.

**Estimate: \$7,000 - 14,000**







**40**  
Two-Face's (Tommy Lee Jones) Glove  
**Batman Forever (1995)**

Two-Face's (Tommy Lee Jones) glove from Joel Schumacher's superhero sequel *Batman Forever*. Two-Face, the criminal alter ego of former district attorney Harvey Dent, split the styles of his outfits directly down the middle, with his scarred side featuring wild colors and patterns and a leather glove.

This lot consists of a fingerless black leather glove with a suede palm and small metal bar embellishments adhered to the knuckles and back of the hand. The leather and metal elements exhibit scuffing from use and age.

**Estimate: \$2,000 - 4,000**



**41**  
Number Six's (Tricia Helfer) Red Dress Costume  
**Battlestar Galactica (2003)**

Number Six's (Tricia Helfer) red dress costume from the sci-fi miniseries *Battlestar Galactica*. Appearing to Dr. Gaius Baltar (James Callis) in a hallucinatory form, Six wore her distinctive dress as she attempted to manipulate him to pursue her own agenda.

Custom-made for the miniseries, the sleeveless and almost backless outfit is constructed from a red poly elastane blend. Completing the costume is a pair of black synthetic leather stiletto sandals with clear plastic studded straps and adhered labels reading "6 No Six 401, 402" on each sole. The outfit is accompanied by a studio certificate of authenticity and a Tricia Helfer-autographed promotional still in silver-color ink. This costume exhibits stretched seams and snagged threads.

**Estimate: \$7,000 - 14,000**



**42**  
Imperious Leader's (Dick Durock) Robe  
**Battlestar Galactica (1978)**

Imperious Leader's (Dick Durock) robe from Glen A. Larson's sci-fi fantasy series *Battlestar Galactica*. As ruler of the robotic Cylon Empire, the Imperious Leader was programmed by Count Iblis (Patrick Macnee) to wage a protracted war against humans.

This burgundy velvet full-body robe features scaled plumage in lavender, off-white, and burgundy festooned with sequins, to emulate reptilian scales as a cultural affectation of their creator's heritage. The high-winged standing collar covers the back of the neck. The robe features a hook-and-loop closure at the back with a singular hook-and-eye clasp. It exhibits missing sequins and feathers from plumage, with a few surviving pieces included in a small polybag, as well as color fading and discoloration.

**Estimate: \$4,000 - 8,000**



**43**  
Pair of Prototype Zafiro Tequila Bottles, Cork, and Drink Menu  
**Better Call Saul (2015-2022)**

A pair of prototype Zafiro tequila bottles, cork, and a drink menu from Vince Gilligan and Peter Gould's prequel series *Better Call Saul*. In the Season 2 episode "Switch," Jimmy McGill (as played by Bob Odenkirk) and Kim Wexler (as played by Rhea Seehorn) pulled a con at a bar to get free shots of the fictional tequila Zafiro Anejo.

This lot consists of one blue tinted acrylic prototype Zafiro bottle; one blue tinted acrylic prototype Zafiro bottle; one bronze-color agave-shaped cork and wood bottle top; and a paper drink menu attached to a dark brown wood and metal clipboard. This lot exhibits stains and bends to the drink menu from production use. Dimensions: (largest) 10" x 4.5" x 3" (25.5 cm x 11.5 cm x 7.75 cm); (smallest) 3.25" x 1.75" x 1.75" (8.5 cm x 3.25 cm x 3.25 cm)

Sony Pictures Television will be donating a portion of the sales proceeds from this lot to the Assistance League of Albuquerque and ABQ Mutual Aid of the SouthWest Organizing Project, two local charities located in Albuquerque, New Mexico where *Better Call Saul* was filmed.

**Estimate: \$5,000 - 10,000**

**44**  
Jimmy McGill's Distressed Stunt Desert Costume  
**Better Call Saul (2015-2022)**

Jimmy McGill's distressed stunt desert costume from Vince Gilligan and Peter Gould's prequel series *Better Call Saul*. In the Season 5 episode "Bagman," McGill (as played by Bob Odenkirk) wore his costume when he trekked through the desert after Mike Ehrmantraut (as played by Jonathan Banks) saved him from a shootout with Lalo Salamanca's (as played by Tony Dalton) bags of money.

This costume consists of a white cotton bloodied and dirtied T-shirt fashioned into a headdress; a navy and red grid design polyester blend suit jacket (size 40) marked "Jimmy PD" on the right armpit; a matching vest (size 40) labeled "Jimmy Prop Vest"; matching bloodied pants (size 34R) marked "Jimmy"; a navy, goldenrod, and red striped wide tie; a bloodied salmon pink poly-cotton button-up shirt marked "XX" along the inside buttons; a pair of orange, black, and gray crew socks; black leather shoes with a green rubber insole (size 10) labeled "Stunt"; a reversible dark brown and black leather belt; and a production tag labeled "STUNT: REECE FLEETWOOD." This costume exhibits intentional distressing throughout from production.

Sony Pictures Television will be donating a portion of the sales proceeds from this lot to the Assistance League of Albuquerque and ABQ Mutual Aid of the SouthWest Organizing Project, two local charities located in Albuquerque, New Mexico where *Better Call Saul* was filmed.

**Estimate: \$8,000 - 16,000**



**45**  
Saul Goodman's (as played by Bob Odenkirk) Briefcase  
**Better Call Saul (2015-2022)**

Saul Goodman's (as played by Bob Odenkirk) briefcase from Vince Gilligan and Peter Gould's prequel series *Better Call Saul*. In the Season 6 episode "Fun and Games," Goodman showed off his future lifestyle as "Saul Goodman" with a new briefcase.

This lot consists of a black leather briefcase with gold-color metal details; 10 yellow card stock business cards; five folded agreement papers; a black and gray plastic and rubber Bluetooth earpiece; a blue and orange ribbon pin; a yellow "Vanillaroma" car scent; a yellow application for leave; one red and two manila file folders with paperwork; a "Special Education Department" booklet; and a functioning-when-powered gray and silver-color plastic flip phone with a black cable charger. This lot exhibits tears and wrinkles throughout the paperwork. Dimensions: (largest) 18" x 13.5" x 4.5" (45.75 cm x 34.5 cm x 11.5 cm); (smallest) 2" x 1" x 0.5" (5 cm x 2.75 cm x 1.5 cm)

Sony Pictures Television will be donating a portion of the sales proceeds from this lot to the Assistance League of Albuquerque and ABQ Mutual Aid of the SouthWest Organizing Project, two local charities located in Albuquerque, New Mexico where *Better Call Saul* was filmed.

Contains electronics; see electronics notice in the Buyer's Guide.

**Estimate: \$7,000 - 14,000**



**46**  
Axel Foley's (Eddie Murphy) Detroit Police ID and Badge  
**Beverly Hills Cop II (1987)**

Axel Foley's (Eddie Murphy) Detroit Police ID and badge from Tony Scott's action comedy sequel *Beverly Hills Cop II*. Foley flashed his badge and ID while identifying himself to construction workers.

This lot consists of a black leatherette bifold wallet with black fabric stitching inset with a plastic "Detroit Police" ID card labeled "Inspector Axel Foley" next to biographical information and a photo of Foley, as well as a metal badge with a gold-color finish and "Police Inspector Detroit" engraved in blue enamel. The ID exhibits staining, while the wallet exhibits tape residue, fraying stitching, and some staining on one side from production. Dimensions: 3.25" x 4.5" x 0.5" (8.25 cm x 11.5 cm x 1.5 cm)

**Estimate: \$8,000 - 16,000**



**47**  
Det. Billy Rosewood's (Judge Reinhold)  
BHPD ID and Badge  
**Beverly Hills Cop (1984)**

Det. Billy Rosewood's (Judge Reinhold) police ID and badge from Martin Brest's action comedy *Beverly Hills Cop*. Rosewood carried his ID and badge throughout the film, including when he flashed them during the shoot-out at Victor Maitland's (Steven Berkoff) estate.

This lot consists of a black leatherette bifold wallet with black fabric stitching inset with a plastic ID card labeled "Detective Sgt. Lou Rosewood" next to biographical information and a photograph of Rosewood, as well as a metal badge with a gold-color finish and "BHPD Police 718" engraved in blue enamel. The lot exhibits holes in the photo, fraying stitching, and cracked leather from production use and age. Dimensions: 3.25" x 4.5" x 0.5" (8.25 cm x 11.5 cm x 1.5 cm)

**Estimate: \$5,000 - 10,000**

**48**  
Andrew Martin's (Robin Williams)  
NDR-114 Robot Costume  
**Bicentennial Man (1999)**

Andrew Martin's (Robin Williams) NDR-114 robot costume from Chris Columbus' sci-fi drama Bicentennial Man. Andrew, an NDR-114 model robot and family housekeeper, sought a way to become more human through inventor Rupert Burns (Oliver Platt) after realizing he was unique.

Williams wore his NDR-114 robot costume in various scenes before transitioning into human form with makeup effects spearheaded by Greg Cannom, who received an Academy Award® nomination for Best Makeup for his work. The role is considered one of the late Williams' most acclaimed dramatic performances.

Created by Steve Johnson FX, this costume consists of an orange- and gray-painted vacuum-formed plastic and fiberglass suit with a metal and foam base and faux gold trim, as well as beige spandex and latex foam hands. The suit features frosted acrylic around the head, thighs, and back to expose the android's "mechanical" components.

This costume comes mounted via an internal armature to a glossy black rounded wooden base on wheels with a gold-color metal plaque engraved "BICENTENNIAL MAN XFX 1999." This lot exhibits cracking material in the hands and back piece from production use, loose panels on the elbows and lower back, and glue residue. Dimensions: 35.5" x 35.5" x 74.5" (90.25 cm x 90.25 cm x 189.25 cm)

Special shipping required; see notice in the Buyer's Guide.

**Estimate: \$60,000 - 120,000**



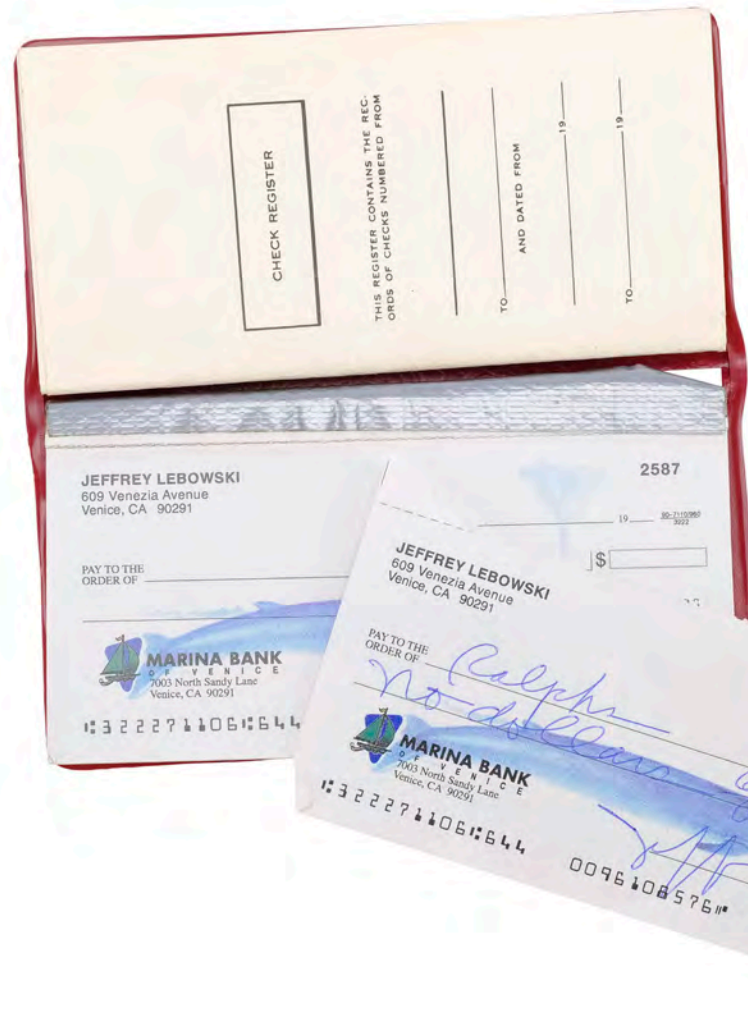

**49**  
**The Dude's (Jeff Bridges) Screen-Matched Handwritten Check with Checkbook Holder and Pad**  
**The Big Lebowski (1998)**

The Dude's (Jeff Bridges) screen-matched, handwritten check with a checkbook holder and pad from Joel and Ethan Coen's mystery comedy The Big Lebowski. Imperfections in the handwriting screen-match to when The Dude paid for his groceries at Ralph's.

This lot consists of a check with a whale illustration labeled for "Jeffrey Lebowski 609 Venezia Avenue Venice, CA 90291," dated "Sept 11 91" in blue ink, and signed "0.69" to Ralph's; a red vinyl checkbook holder with a hand-annotated check register booklet; and a check pad distressed by production to appear used. The lot exhibits creasing, sticky residue and adhesive loss in the pad, and discoloration throughout. Dimensions: (largest) 6.25" x 3.5" x 0.5" (16 cm x 9 cm x 1.5 cm)

**Estimate: \$5,000 - 10,000**



Cinematic Collection / Alamy Stock Photo

**50**  
**The Dude's (Jeff Bridges) Screen-Matched Sunglasses**  
**The Big Lebowski (1998)**

The Dude's (Jeff Bridges) screen-matched sunglasses from Joel and Ethan Coen's mystery comedy The Big Lebowski. The Dude wore his signature sunglasses throughout the film as he got roped into searching for the allegedly kidnapped Bunny Lebowski (Tara Reid). The tortoiseshell pattern and production-applied distressing of these sunglasses screen-match to when the Dude wrote a check at the grocery store in the film's opening.

This pair of Vuarnet Black Legend 03 glasses features aviator-style nylon frames modeled on those worn by U.S. Air Force pilots with a bar above the bridge and amber-color polycarbonate lenses. The bridge exhibits staining on the bottom and the lenses exhibit visible scratching, staining, and grime caught in the edges from production wear.

**Estimate: \$5,000 - 10,000**



**51**  
**The Dude's (Jeff Bridges) Bathrobe**  
**The Big Lebowski (1998)**

The Dude's (Jeff Bridges) bathrobe from Joel and Ethan Coen's mystery comedy The Big Lebowski. The Dude wore his signature bathrobe while shopping at Ralph's and at his home throughout the film.

This beige ribbed cotton bathrobe features two front pockets and a matching belt that ties around the waist. Also included are two production tags reading "Hero Robe 'Dude'" and "Hero Robe Chg 1 Sc 2.5 Chg 4 Sc 12-14." The robe exhibits a few loose threads and the tags exhibit some creasing.

**Estimate: \$15,000 - 30,000**



**52**  
**Walter Sobchak's (John Goodman) Prescription Shooter Glasses**  
**The Big Lebowski (1998)**

Walter Sobchak's (John Goodman) prescription Shooter glasses from Joel and Ethan Coen's mystery comedy The Big Lebowski. Walter wore his signature glasses throughout the film as he tried to solve the mystery of Bunny Lebowski's (Tara Reid) kidnapping with his best friend, The Dude (Jeff Bridges).

This pair of customized Ray-Ban Kalichrome Shooter-style sunglasses features chrome-color metal frames with wraparound cable ear stems, a bar over the bridge, and tinted Aviator Ambermatic-color polycarbonate lenses in the prescription of the performer. The glasses exhibit flaking and tarnishing around the lenses' edges and staining to the rubber nose pads from production wear.

**Estimate: \$5,000 - 10,000**



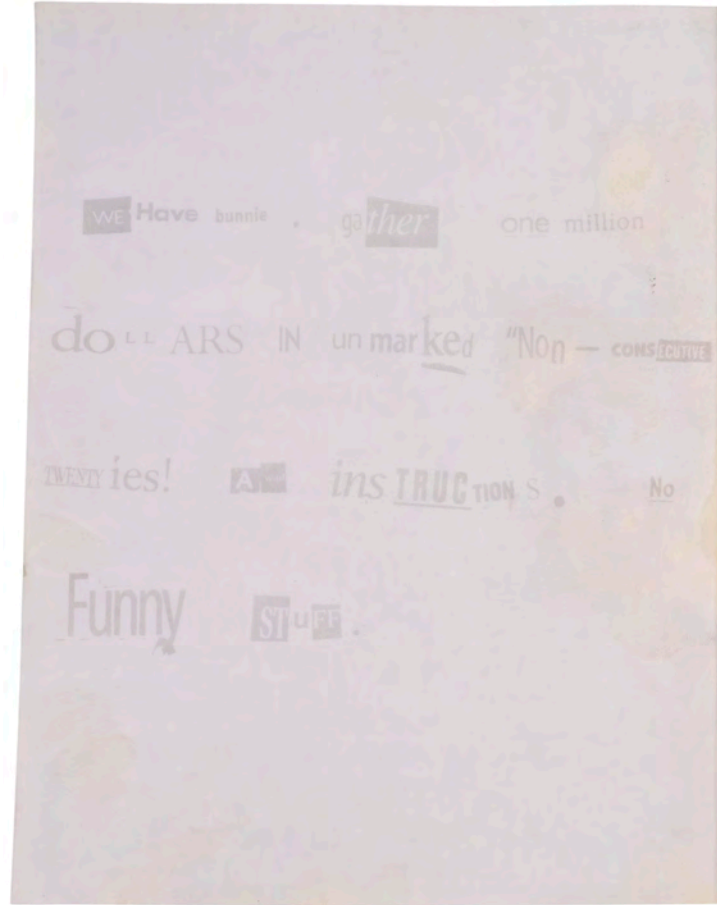

**53**  
**Bunny Lebowski's (Tara Reid) Screen-Matched Ransom Letter with Production-Made Source Letter**  
**The Big Lebowski (1998)**

Bunny Lebowski's (Tara Reid) screen-matched ransom letter with a production-made source letter from Joel and Ethan Coen's mystery comedy The Big Lebowski. Folds and markings on the photocopied letter screen-match to the scene when The Big Lebowski (David Huddleston) showed the ransom letter a group of Nihilists sent for his disappeared wife to The Dude (Jeff Bridges).

This lot consists of a black-and-white photocopied ransom letter as well as the hand-made source letter that production put together to create the photocopy from. The source letter is taped with multicolor paper cutouts reading "We Have Bunnie. Gather one million dollars in unmarked non-consecutive twenties! Await instructions. No stuff." Some cutouts have flaked off of the source letter from age, such as the word "funny," and the copy exhibits edge wear and liquid staining. Dimensions: (each) 8.5" x 11" (21.75 cm x 28 cm)

**Estimate: \$4,000 - 8,000**

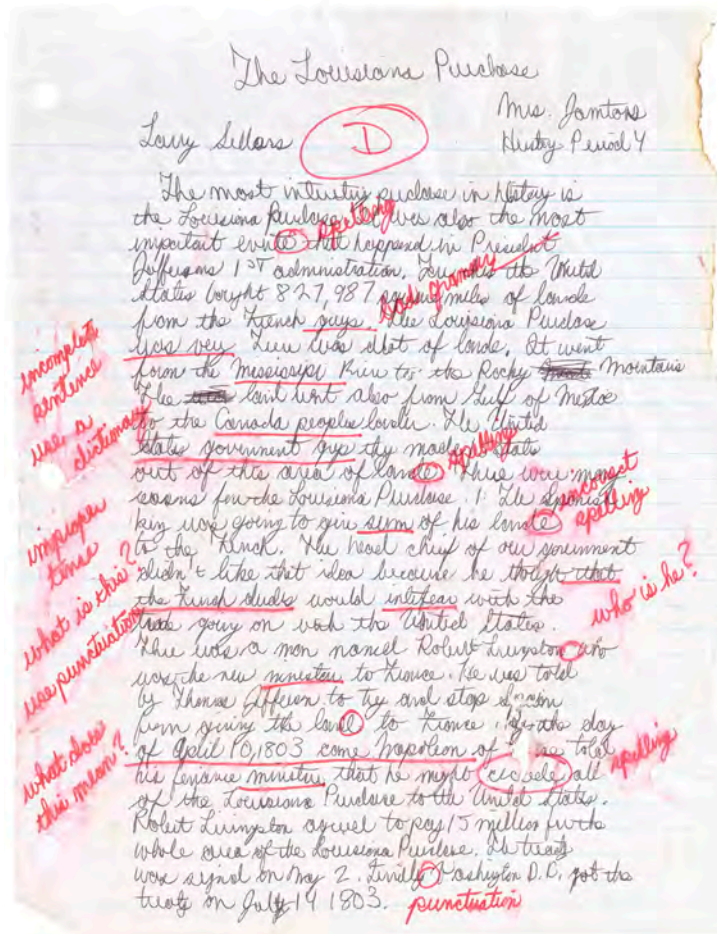

**54**  
**Larry Sellers' (Jesse Flanagan) Screen-Matched Handwritten Homework**  
**The Big Lebowski (1998)**

Larry Sellers' (Jesse Flanagan) screen-matched, handwritten homework from Joel and Ethan Coen's mystery comedy The Big Lebowski. This lot screen-matches to the wide shot in which The Dude (Jeff Bridges) first saw the homework in his trunk after the teenaged Sellers stole his car.

This essay titled "The Louisiana Purchase" and authored by "Larry Sellers" is handwritten in black ink with a "D" grade and various corrections made in red ink on hole-punched and lined U.S. letter-size paper. The paper exhibits intentional distressing by production to appear damaged with liquid stains, tearing, and burns along the edges. Dimensions: 8.5" x 11" (21.75 cm x 28 cm)

Sold without copyright; see notice in the Buyer's Guide.

**Estimate: \$4,000 - 8,000**



**55**  
**Bunny Lebowski's (Tara Reid) Screen-Matched Severed Toe**  
**The Big Lebowski (1998)**

Bunny Lebowski's (Tara Reid) screen-matched severed toe from Joel and Ethan Coen's mystery comedy The Big Lebowski. Imperfections on the nail screen-match this toe to when The Dude (Jeff Bridges) received what he believed to be Bunny's toe after failing to provide her alleged kidnappers with her ransom.

This molded silicone toe is inset with an acrylic nail painted green and bloodied by production. It exhibits minor grime from production use and stickiness from age. Dimensions: 1" x 0.5" x 0.5" (2.75 cm x 1.5 cm x 1.5 cm)

**Estimate: \$4,000 - 8,000**



**56**  
**Jackie Treehorn's (Ben Gazzara) Screen-Matched Pornographic Drawing**  
**The Big Lebowski (1998)**

Jackie Treehorn's (Ben Gazzara) screen-matched pornographic drawing from Joel and Ethan Coen's mystery comedy The Big Lebowski. The Dude (Jeff Bridges) attempted to recreate what Treehorn wrote in his notepad, but his shading instead revealed a pornographic drawing. This drawing screen-matches to the moment when the Malibu Police Chief (Leon Russom) found the drawing in The Dude's wallet following his arrest.

This explicit drawing of a nude figure is rendered in shaded graphite custom cream-color letterhead labeled "Treehorn" on top. The drawing exhibits intentional distressing by production with fold lines, crumpling, and brown stains to appear used. Dimensions: 4" x 6" (10.25 cm x 15.25 cm)

Sold without copyright; see notice in the Buyer's Guide.

**Estimate: \$5,000 - 10,000**



Maximum Film / Alamy Stock Photo



**57**  
The Dude's (Jeff Bridges) Screen-Matched  
Dream Sequence Lightweight Bowling Ball  
**The Big Lebowski (1998)**

The Dude's (Jeff Bridges) screen-matched dream sequence lightweight bowling ball from Joel and Ethan Coen's mystery comedy *The Big Lebowski*. This bowling ball screen-matches to one of The Dude's (Jeff Bridges) dream sequences, in which he flew while holding a ball that ultimately dropped him to the ground. The Dude also carried his signature ball in a second dream sequence.

This lightweight bowling ball is constructed from dense styrofoam painted red and black with a Brunswick logo and engraved "944 199" and "Black Beauty." It exhibits minor grime from age and minor dents from production. Dimensions: 8" x 8" x 8" (20.5 cm x 20.5 cm x 20.5 cm)

**Estimate: \$5,000 - 10,000**



**58**  
The Dude's (Jeff Bridges) Flying Harness  
Coveralls and Boots  
**The Big Lebowski (1998)**

The Dude's (Jeff Bridges) flying harness coveralls and boots from Joel and Ethan Coen's mystery comedy *The Big Lebowski*. After being drugged by Jackie Treehorn (Ben Gazzara), Jeff Lebowski, aka The Dude, wore his coveralls in a dream-like musical sequence while floating down a bowling lane and rotating under a sign reading "Bowling Ball Girls." He also wore his black work boots while a miniature version of himself danced before he switched to bowling shoes.

This lot consists of white coveralls marked "Hero" on the interior with removed sleeves and both hook-and-loop and snap-button closures on front, as well as a fastening strip in seam for the harness used to suspend Lebowski; a pair of black leather and rubber work boots for the miniature sequence; and two wardrobe tags marked "DUDE HERO CH 12 SC 57 PT WORK BOOTS" and "#6230 JEFF BRIDGES 'big lebowski' 1." The coveralls exhibit minimal black scuffing on the bottoms of the legs.

**Estimate: \$5,000 - 10,000**



**59**  
The Dude's (Jeff Bridges) Tool Belt  
**The Big Lebowski (1998)**

The Dude's (Jeff Bridges) tool belt from Joel and Ethan Coen's mystery comedy *The Big Lebowski*. The Dude wore his tool belt when he was chased by a giant bowling ball during a drug-induced hallucination.

This lot consists of a black leather tool belt with a metal buckle, studs, chains, and pockets; a wooden hammer with a metal head; a metal ratcheting screwdriver with a green urethane grip; a plastic level with two ethanol vials; and one roll each of red and gray tape. The hammer's head has come loose, the tape exhibits liquid staining and warping, and the lot exhibits scuffing and scratching throughout from production use.

**Estimate: \$4,000 - 8,000**



**60**  
The Big Lebowski's (David Huddleston)  
Framed Time Man of the Year Mirror  
**The Big Lebowski (1998)**

The Big Lebowski's (David Huddleston) framed Time Man of the Year mirror from Joel and Ethan Coen's mystery comedy *The Big Lebowski*. The Dude (Jeff Bridges) checked himself out in Lebowski's mirror when they met to discuss the kidnapping of Bunny Lebowski (Tara Reid).

This mirror is applied with red and white text decals reading "Man of the Year" and "Time" at top and "Are You a Lebowski Achiever?" referring to The Big Lebowski's social welfare program at bottom. It comes mounted in a black wooden frame with a hanging wire custom-made for the production by Hollywood Cinema Arts. The frame exhibits hanging holes and torn paper backing from production use, and the mirror exhibits some grime. Dimensions: 15.5" x 12.25" x 0.75" (39.5 cm x 31.25 cm x 2 cm)

**Estimate: \$4,000 - 8,000**



**61**  
 The Dude's (Jeff Bridges) White Russian Tumblers  
**The Big Lebowski (1998)**

The Dude's (Jeff Bridges) White Russian tumblers from Joel and Ethan Coen's mystery comedy *The Big Lebowski*. The Dude drank his favored White Russians out of whiskey tumblers throughout the film.

This lot consists of two whiskey glasses: one with a diamond crystal pattern and one with a square diamond crystal pattern. They exhibit scratches and grime from production use. Dimensions: (each) 3.5" x 3.5" x 3.5" (9 cm x 9 cm x 9 cm)

**Estimate: \$2,000 - 4,000**



**63**  
 The Dude's (Jeff Bridges) License Plate  
**The Big Lebowski (1998)**

The Dude's (Jeff Bridges) license plate from Joel and Ethan Coen's mystery comedy *The Big Lebowski*. Teenager Larry Sellers (Jesse Flanagan) stole The Dude's car while The Dude bowled with his team.

This blue aluminum California license plate features number "376PCE" printed in gold-color, decals reading "Sep" and "CA90" applied on the top corners, and four screw holes for affixing to a car. Its reverse is hand-labeled "Dude's" and "Ritchie" for property master Ritchie Kremer in black marker. The plate exhibits scuffing and grime staining throughout from production use. Dimensions: 12" x 6" x 0.5" (30.5 cm x 15.25 cm x 1.5 cm)

**Estimate: \$1,500 - 3,000**



**64**  
 Blade's (Wesley Snipes) Costume Display  
**Blade: Trinity (2004)**

Blade's (Wesley Snipes) costume display from David S. Goyer's superhero horror sequel *Blade: Trinity*. A vampire born with the ability to walk in the sunlight, Blade wore his costume as he teamed up with a group, the Nightstalkers, to battle a resurrected Dracula (Dominic Purcell) and his murderous army of the night.

This costume consists of a dark red, long-sleeve bodysuit; a black zippered leatherette and nylon vest with padded armor blocks and metal buckles; black suede and neoprene gloves; black trousers marked "WES" in the interior; a black imitation leather duster lined with red satin, and boots. This costume comes dressed on a custom mannequin affixed with a silicone Blade mannequin head. This display exhibits some discoloration and scratching on the leather jacket. Dimensions: 74.5" x 26" x 14" (189.25 cm x 66.25 cm x 35.75 cm)

Special shipping required; see notice in the Buyer's Guide.

**Estimate: \$7,000 - 14,000**



**62**  
 Walter Sobchak (John Goodman) and Donny Kerabatsos' (Steve Buscemi) Bowling Ball Bags  
**The Big Lebowski (1998)**

Walter Sobchak (John Goodman) and Donny Kerabatsos' (Steve Buscemi) bowling ball bags from Joel and Ethan Coen's mystery comedy *The Big Lebowski*. Walter and Donny brought their personal bowling ball bags to the bowling league they played in with *The Dude* (Jeff Bridges).

This lot consists of a brown leather and wood bowling bag; a red and white leather and cardboard bowling ball bag with an internal metal stand; a white cloth towel labeled "I [Heart] Bowling"; two matchbooks; a white leather dual-control wrist guard (ladies size Small); three ball cleaner towelettes; and three skin protector patch packs. This lot exhibits grime and disintegration from age. Dimensions: 12.5" x 8" x 14" (31.75 cm x 20.5 cm x 35.75 cm)

**Estimate: \$2,000 - 4,000**



**65**  
Blade's (Wesley Snipes) Hero Daywalker Sword  
**Blade (1998)**

Blade's (Wesley Snipes) hero daywalker sword from Stephen Norrington's action horror Blade. The half-human, half-vampire carried his sword in multiple scenes throughout the film and wielded it as he battled Deacon Frost (Stephen Dorff) after he'd become the avatar of the supreme blood god La Magra.

This lot, originally sourced from a member of the film's prop department, consists of one metal sword with an aluminum blade inset into a ribbed, machined aluminum grip. Finished in black and silver-color paint, the round grip is flattened on one side, features vertical grooves that separate the ribbed rings, and is decorated with ornate embossed vampiric glyphs at the top and bottom. The grip has a neck collar, as seen in the film, though it has no functionality and a notch that prevents it from rotating fully. This sword exhibits some scuffing to its finish, as well as some residue and discoloration along the blade and grip. Dimensions: 35.5" x 2" x 2" (90.25 cm x 5 cm x 5 cm)

Blade was dulled by production.

**Estimate: \$25,000 - 50,000**



United Archives GmbH / Alamy Stock Photo

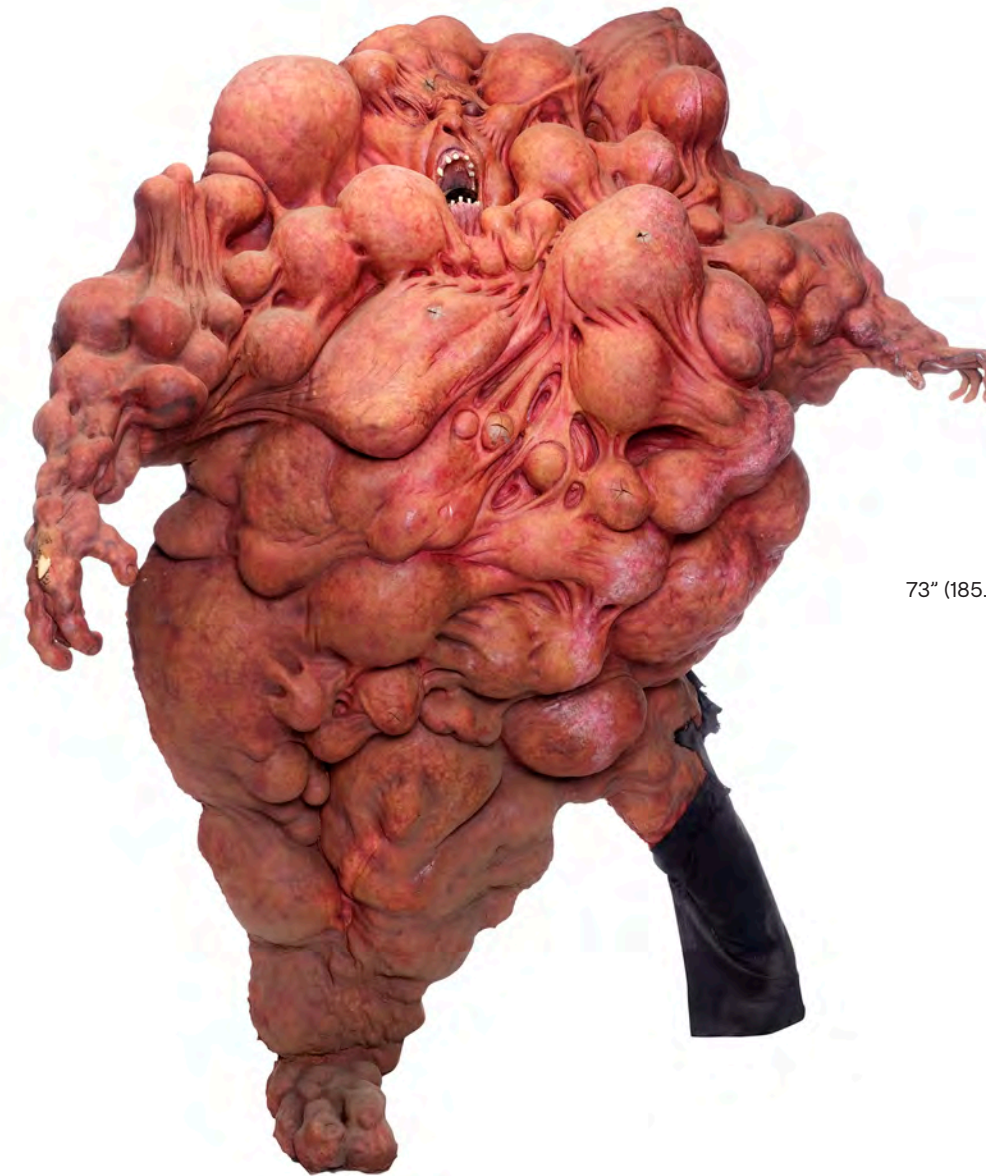

73" (185.5 cm)

**66**  
Frost's (Stephen Dorff) Full-Size Exploding Body on Display  
**Blade (1998)**

Frost's (Stephen Dorff) full-size exploding body display from Stephen Norrington's action horror film Blade. Frost exploded after being shot with EDTA darts.

Created by effects artist Gary Tunnicliffe, this foam-filled latex body was shot for the film and digitally morphed between shots of Dorff in SFX makeup and an additional "bubbling" body for the explosion sequence. This body features synthetic hair, resin vampire teeth, the remnants of a black polyester pant leg, and production-made X-holes used to indicate where darts would have punctured Frost. It comes mounted via a metal stand to a rolling wooden display. The lot exhibits some latex fragility; minor cracks, rips, and tears; and discoloration. Dimensions: 60" x 38" x 73" (152.5 cm x 95.5 cm x 185.5 cm)

Special shipping required; see notice in the Buyer's Guide.

**Estimate: \$4,000 - 8,000**



**67**  
Blade's (Wesley Snipes) Stunt Daywalker Sword  
**Blade (1998)**

Blade's (Wesley Snipes) stunt Daywalker sword from Stephen Norrington's action horror film Blade. The half-human, half-vampire Blade wielded his signature sword throughout the film, including when he battled Deacon Frost (Stephen Dorff) when Frost became the avatar of the supreme blood god La Magra.

Designed by swordmaker Tony Swatton, this stunt sword features a rubber blade painted silver-color to appear metallic and inset with a black cast resin grip engraved with vampiric glyphs. It exhibits cracking to the rubber, some exposed resin, and a broken tip from production use. Dimensions: 30" x 2" x 2" (76.25 cm x 5 cm x 5 cm)

**Estimate: \$5,000 - 10,000**



**68**  
 Rick Deckard's (Harrison Ford) Screen-Matched and Photo-Matched Costume from Voight-Kampff and Roy Batty (Rutger Hauer) Fight Scenes  
**Blade Runner (1982)**

Rick Deckard's (Harrison Ford) screen-matched and photo-matched costume from Ridley Scott's sci-fi classic Blade Runner. Deckard administered the Voight-Kampff test to Rachel (Sean Young), and later fought Roy Batty (Rutger Hauer) before Batty ultimately saved him from falling.

Among the most acclaimed and debated science-fiction films in history, Blade Runner has no fewer than seven different versions, including a 1992 director's cut and a so-called "final" cut overseen by Scott and released in 2007. Despite a lackluster theatrical release, the film's success on home-video helped inspire artistic movements in the neo-noir and cyberpunk genres and led to many additional adaptations of author Philip K. Dick's stories. Blade Runner was ultimately selected for preservation in the US National Film Registry in 1993, and Rick Deckard has become one of Ford's crowning roles alongside Han Solo and Indiana Jones.

Designed by Michael Kaplan and originating from a private Hollywood collection, this costume contains both screen- and photo-matched components. The orange wool and cotton tweed jacket with a single button and three pockets screen-matches to the Voight-Kampff scene, though it was later bloodied by production with visible streaks on the lapel. Deckard also wore a different shirt and pants in the Voight-Kampff scene than appear in this lot. In fact, patterns on the blue poly-blend button-up shirt with two front pockets and red plastic buttons, specifically on the collar, match it to publicity photos from the Batty fight.

This costume also includes a pair of orange wool and cotton tweed pants with an Itai Costume tag labeled "Ford Harrison" on the interior; brown leatherette lace-up Adidas "Official" model sneakers with rubber soles; and four wardrobe tags, including one hand-labeled "Condition of Suit when Deckard Returns After Batty Fight." The sneakers were originally black, but were painted brown with added Adidas markings by the costume department. The Adidas markings have since been removed and the inner sole liners were also changed out. One original shoelace from production is included, while the laces currently on the shoes are replicas. Also included are two production stills.

This costume is intentionally distressed throughout by production to appear damaged and grimy with pilling to the tweed, fraying at the ankles, and various discolored stains.

**Estimate: \$80,000 - 160,000**



Pictorial Press Ltd / Alamy Stock Photo



**69**  
Rick Deckard's (Harrison Ford) Apartment Wall Panel  
**Blade Runner (1982)**

Rick Deckard's (Harrison Ford) apartment wall panel from Ridley Scott's sci-fi drama Blade Runner. Deckard returned to his apartment after beginning his investigation and discovered Rachael (Sean Young) waiting for him.

This lot consists of one wall panel. Made up of a plastic vacuum-formed pull attached to a wooden board, this panel features a geometric design inspired by the Ennis-Brown House designed by Frank Lloyd. As with the Ennis-Brown House's construction of concrete blocks, this panel was painted to resemble stone with a sand-color base and overlapping flecks of beige, brown, and gray. This lot exhibits cracking, pitting, and rough edges. Dimensions: 17" x 18" x 2.5" (43.25 cm x 45.75 cm x 6.5 cm)

**Estimate: \$4,000 - 8,000**



**70**  
Terry Rawlings Collection: Pair of  
Rick Deckard's (Harrison Ford)  
Apartment Glass Whiskey Tumblers  
**Blade Runner (1982)**

A pair of Rick Deckard's (Harrison Ford) glass tumblers from Ridley Scott's sci-fi classic Blade Runner. Deckard sipped whiskey from one of his glass tumblers whilst viewing video in his apartment.

These distinctive, angular glass tumblers come from the estate of supervising editor Terry Rawlings. Designed in 1973 for the Cibi Collection by Cini Boeri and produced by glassware company Arnolfo di Cambio, Scott selected these glasses due to their striking, futuristic design. Both feature the Cibi logo on their octagonal bases. Dimensions: (pair) 3.75" x 6.5" x 3.25" (9.25 cm x 17 cm x 8.5 cm)

**Estimate: \$4,000 - 8,000**

**71**  
Rick Deckard's (Harrison Ford)  
Pistol Components  
**Blade Runner (1982)**

Rick Deckard's (Harrison Ford) pistol components from Ridley Scott's sci-fi classic Blade Runner. Deckard carried his signature pistol while searching for escaped replicants.

This lot consists of two translucent amber resin pistol grips with pearlescent finishes and screw holes for affixing to a pistol body, as well as a black resin back-up ammo cartridge with logo engravings on front. Also included is a Certificate of Authenticity from archivist Bryan Ebenhoch and a product information sheet. This lot exhibits residue, scratches, pitting, tears and loose components. Dimensions: (largest) 5" x 2" x 1" (12.75 cm x 5.25 cm x 2.75 cm)

**Estimate: \$3,000 - 6,000**



# Propstore

# Wanted

## Sell Your Posters

Movie, Travel, Event, War, Advertising,  
Alternative Art, Original Artwork

Sell Your Memorabilia with Propstore to  
Maximize Your Return

**Cimarron (RKO, 1931)**  
One Sheet (27" X 41")  
Very Good on Linen

Estimate: \$50,000-100,000



Propstore CA Bond #7285BGU4116

[propstore.com/sell](https://propstore.com/sell)



**72**  
**Richard Edlund Collection: Custom-Made 65mm VFX Matte Camera Used on Blade Runner and Close Encounters of the Third Kind**  
**Blade Runner (1982)**

A custom-made 65mm VFX matte camera from Blade Runner and Close Encounters of the Third Kind. This matte camera was first made as a bi-pack camera by George Randle for Pacific Title, Hollywood's premier title and optical house that was founded in 1919. It was later acquired by Doug Trumbull and put into service as the matte department's camera on "Close Encounters." In 1983, noted VFX Supervisor Richard Edlund formed BOSS Film Corp and acquired Trumbull's EEG facility and equipment. This camera ultimately formed the backbone of the matte department.

This lot comes from the collection of Academy Award®-winning VFX supervisor Richard Edlund and includes a Letter of Authenticity from Edlund. It consists of one matte camera with a stack of three magazines. Filming matte paintings requires cameras to have two stacks of magazines, known as "bi-packing," which allows the camera to film a matte painting with another piece of film next to the negative. Thus both are recorded on a single piece of film in a single pass and show a greatly enhanced image quality of the resulting composite. Famed matte artist Matthew Yuricich used this camera to photograph all of the matte paintings on "Close Encounters" and "Blade Runner." Later, it was further upgraded by adding another set of magazines making it a tri-pack, as it currently appears. It was used on virtually every project that BOSS Film worked on that required matte paintings, like: "Ghostbusters," "2010," "Batman Returns," "Species," "Cliffhanger," and more.

Constructed of metal with glass lenses and plastic components, this camera features several taped labels hand-marked for "460," "350," "CM/BC," "SE PS [sic]," "5248-363," and "Focus." Known for its steadiness, this camera was mounted to a fixed pedestal that would face the matte stand. It is complete with inner movement, tri-pack magazines, and lens with cover. This lot exhibits adhesive residue, lifted tape, a buildup of grime, and fragile components.

Dimensions: 26.25" x 14" x 42.5" (66.75 cm x 35.5 cm x 108 cm)

Contains electronics and mechanical components; see notice in the Buyer's Guide. Special shipping required; see notice in the Buyer's Guide.

**Estimate: \$25,000 - 50,000**



Steven Spielberg and VFX Supervisor Douglas Trumbull with this Matte Camera on Close Encounters of the Third Kind

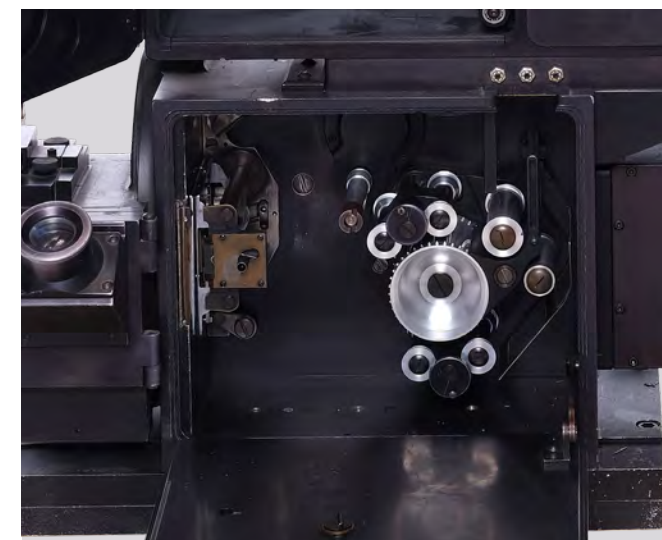

**73**  
**Richard Edlund Collection:**  
**65mm Mitchell FC Camera**  
**Boss Films VFX Company**

A 65mm Mitchell FC camera from the Boss Films VFX company. To counter the decline in movie attendance starting in the late 50's, film makers and camera manufacturers turned to larger format film cameras. 65mm film has an image area more than three times the size of a standard 35mm frame. Due largely to the expense of the film and processing, shooting on 65mm was limited to large, epic films such as "Bridge on the River Kwai", "2001: A Space Odyssey", and "Lawrence of Arabia". Non-blipped cameras, such as this, were typically included as part of a camera package to be used for capturing MOS (silent) footage.

This lot comes from the collection of Academy Award®-winning VFX supervisor Richard Edlund and includes a Letter of Authenticity from Edlund. This camera, serial number 6560, was initially sold to Claude Chevereau's "Chevereau au Service du Cinema" rental house in Paris in late 1962 and was notably unique in that it had the capability to film at a higher frame rate than the standard 24fps, making it ideal for action sequences. While specific camera reports have not been located showing its usage, conversations between Richard Edlund and Stanley Kubrick in the mid-1990's indicate this could have been part of a larger package of equipment that worked on classic films based out of Europe in the mid-late 1960's. Later, VFX Supervisor Richard Edlund purchased this camera directly from Claude Chevereau in 1993 to be used as a higher speed VFX camera for his BOSS Film VFX company.

This lot consists of one 65mm Mitchell FC camera, which very few FC cameras were ever made by Mitchell, is composed of metal with glass lenses and plastic components and features matching serial numbers on the body and movement, lens, as well as the attached high speed motor. This camera features a single lens mount rather than a turret lens, and is a rackover camera rather than a reflex camera. It also comes with a Taylor & Hobson 30mm lens; a 65mm magazine with case; its original camera case; and a power supply and speed control engineered by BOSS Film. This lot exhibits adhesive residue, a buildup of grime, and fragile components. Dimensions: 27" x 12.5" x 21.5" (68.75 cm x 31.75 cm x 54.75 cm)

Contains electronics and mechanical components; see notice in the Buyer's Guide.

Special shipping required; see notice in the Buyer's Guide.

**Estimate: \$25,000 - 50,000**

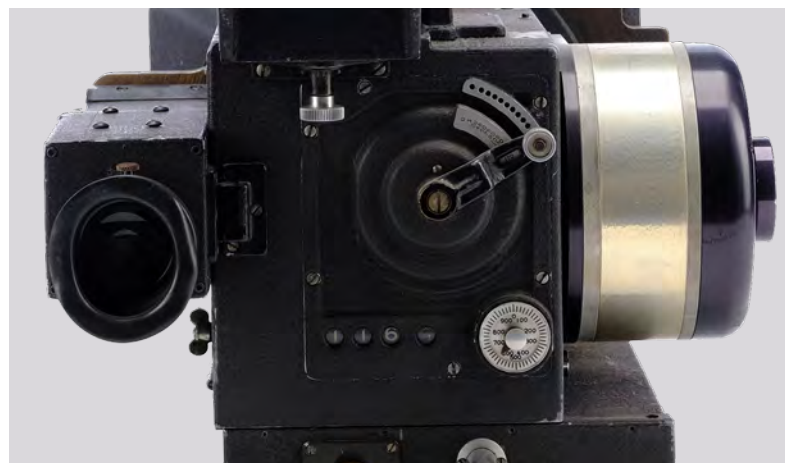
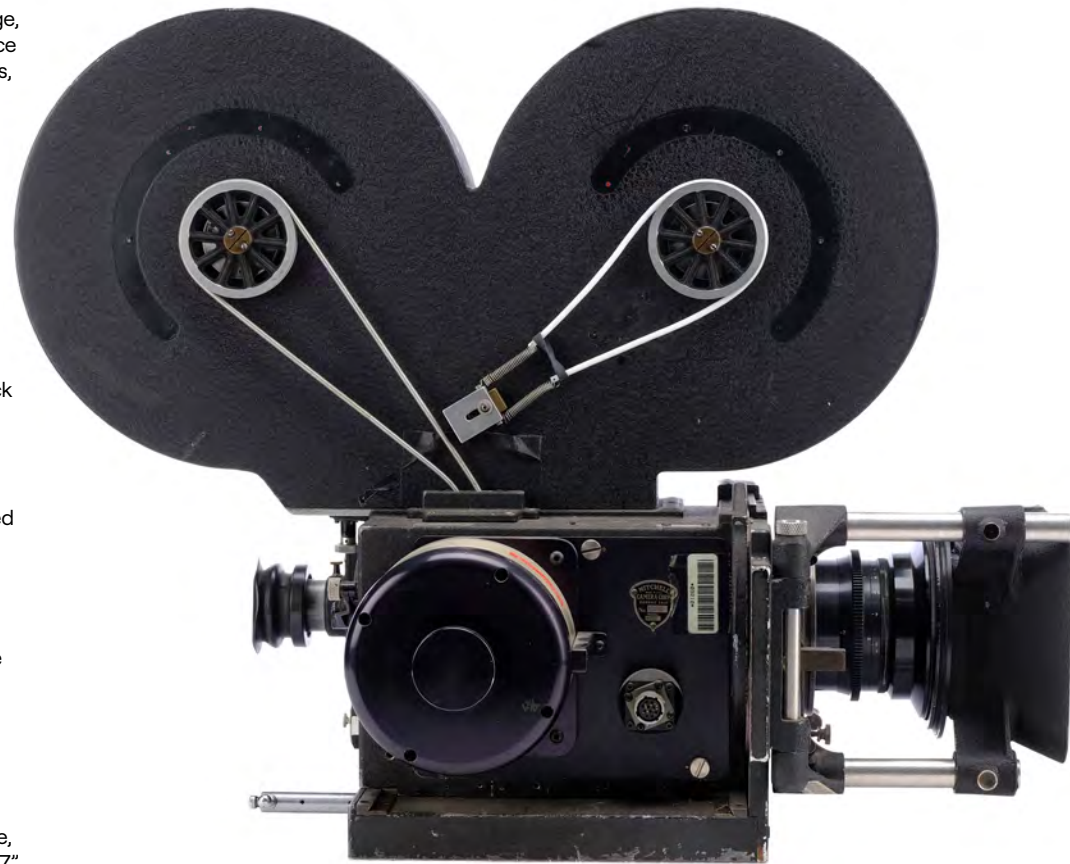



**74**  
 Dirk Diggler's (Mark Wahlberg) Photo-Matched  
 Costume  
**Boogie Nights (1997)**

Dirk Diggler's (Mark Wahlberg) photo-matched costume from Paul Thomas Anderson's drama film Boogie Nights. Diggler wore his costume as his character Brock Landers in the opening scene to his adult film Brock Landers: Angels Live in My Town. The striping on the lapel matches to publicity photos from the film.

This lot consists of a brown pinstripe three-piece suit; dark brown briefs (size 36); blue and brown frame aviator sunglasses with brown lenses and a magenta case marked "DIRK"; a brown and white block polyester-blend scarf with brown fringe; a cream-color button-down shirt featuring people on a balcony across the chest and left arm; and six production tags. This lot exhibits minor loose threads on the scarf.

**Estimate: \$4,000 - 8,000**



**75**  
 Rollergirl's (Heather Graham) Bathing Suit Top  
**Boogie Nights (1997)**

Rollergirl's (Heather Graham) bathing suit top from Paul Thomas Anderson's drama film Boogie Nights. Rollergirl wore her bathing suit at Jack Horner's (Burt Reynolds) house while taking photos of Eddie Adams (Mark Wahlberg) and Reed Rothchild (John C. Reilly) at the outdoor bar.

This lot consists of a pink, peach, yellow, green and brown polka dot and motif spandex halter swimsuit top and two production tags. The top exhibits minor holes in the lining.

**Estimate: \$2,000 - 4,000**



**76**  
 Hand-Painted Brian Flora Impaled  
 Victims at Dracula's Castle  
 Matte Painting  
**Bram Stoker's Dracula (1992)**

A hand-painted Brian Flora impaled victims at Dracula's castle matte painting from Francis Ford Coppola's horror adaptation Bram Stoker's Dracula. Vlad Dracula (Gary Oldman) raced through a pass of impaled people to return home to his beloved Elisabeta (Winona Ryder).

This lot consists of one oversize matte painting on a framed panel of glass. It features an image of a canyon pass lined with impaled people and the sun off in the distance. It also features an unpainted road portion where the live action footage was composited. The back features tape and "Tape Here" hand-marked, as well as "Line up" next to the unpainted area. This lot exhibits chipped paint, smudging, notable tape residue, and scratches. Dimensions: 49.5" x 61" x 1" (125.75 cm x 155 cm x 2.5 cm)

Special shipping required; see notice in the Buyer's Guide.

Sold without copyright. See notice in the Buyer's Guide.

**Estimate: \$6,000 - 12,000**

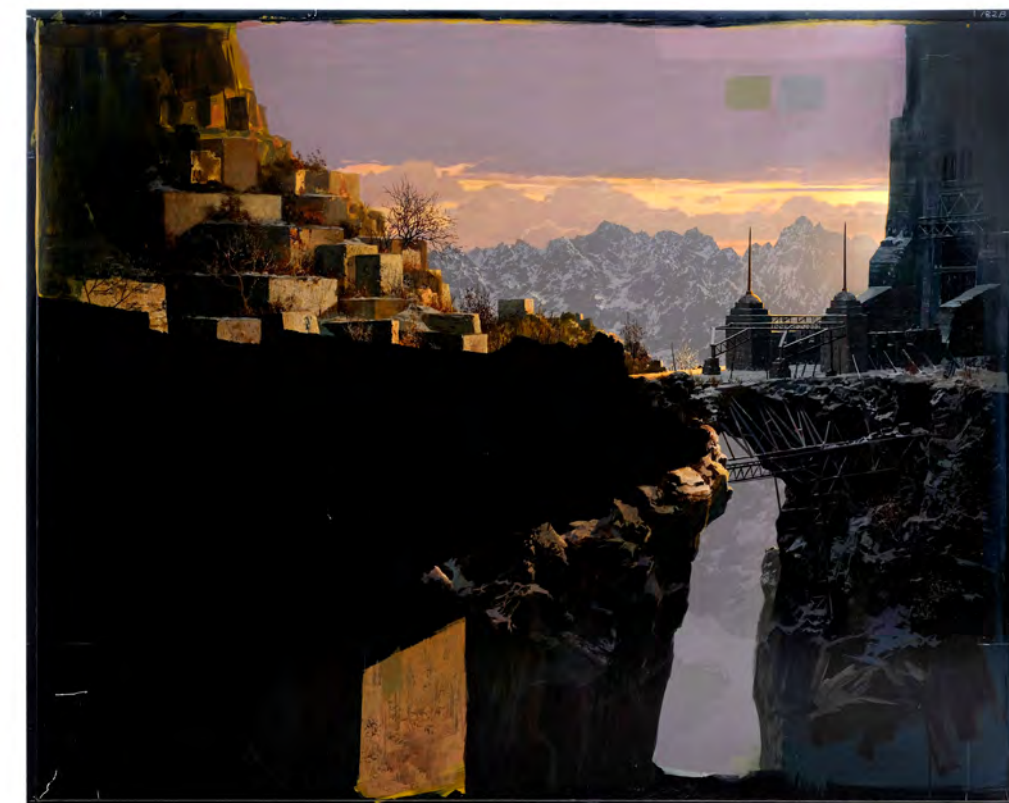

**77**  
 Hand-Painted Bill Mather Dracula's  
 Castle at Sunrise Matte Painting  
**Bram Stoker's Dracula (1992)**

A hand-painted Bill Mather Dracula's castle at sunrise matte painting from Francis Ford Coppola's Bram Stoker's Dracula. Jonathan Harker (Keanu Reeves) and others chased Dracula (Gary Oldman) back to his castle.

This lot consists of one oversize matte painting on a framed glass panel. It features a hand-painted image of a snowy pass and castle gates with an unpainted path portion where the live action footage was composited. It also features a hand-marked "1/82B" on the upper right corner. This lot exhibits chipped paint, scratches, lifted tape, and smudging. Dimensions: 49.5" x 61" x 1" (125.75 cm x 155 cm x 2.5 cm)

Special shipping required; see notice in the Buyer's Guide.

Sold without copyright. See notice in the Buyer's Guide.

**Estimate: \$4,000 - 8,000**



Moviestore Collection Ltd / Alamy Stock Photo



**78**  
**William Wallace's (Mel Gibson) Scottish Claymore Sword**  
**Braveheart (1995)**

William Wallace's (Mel Gibson) Scottish claymore sword from Mel Gibson's historical drama Braveheart. Wallace wielded his sword throughout the film as he fought against the English soldiers and demanded the freedom of his fellow Scotsmen.

This weapon is made of aluminum and features a leather-wrapped wooden grip and blade shoulder with a loose leather strip. It has a wide silver-color painted semi-flex resin cross guard and a rounded aluminum pommel. The blade and pommel have been intentionally tarnished to look well used and aged, with nicks and dents along the length of the sword to give it a battle worn appearance. This lot exhibits chipping paint on the cross guard imperfections on the blade shoulder's leather, and a loose pommel. Dimensions: 60.5" x 12.5" x 1.5" (153.75 cm x 31.75 cm x 4 cm)

Special shipping required; see notice in the Buyer's Guide.

**Estimate: \$50,000 - 100,000**

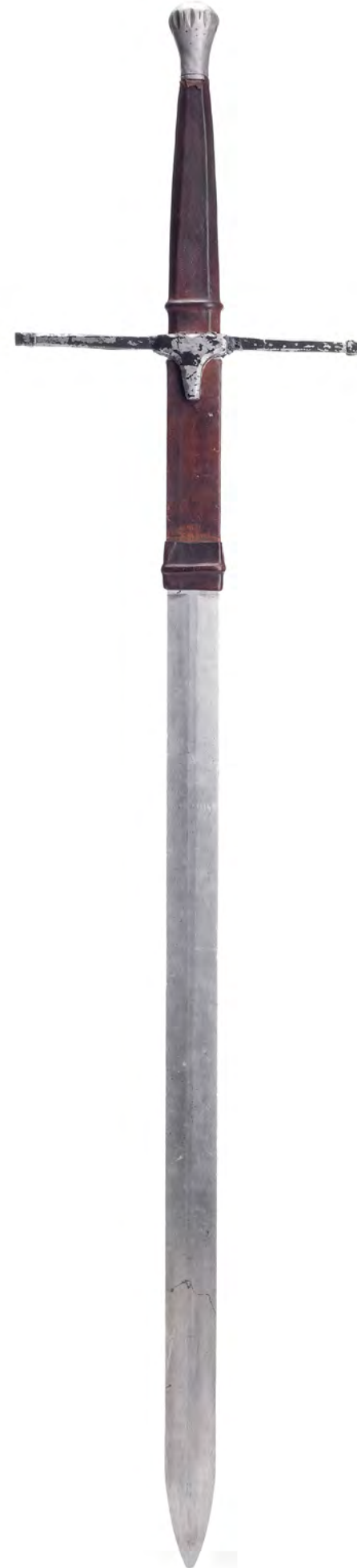

**79**  
 William Wallace's (Mel Gibson)  
 Screen-Matched Battle Damaged  
 Chest Armor  
**Braveheart (1995)**

William Wallace's (Mel Gibson) screen-matched, battle-damaged chest armor from Mel Gibson's historical drama Braveheart. The damage and entry wounds on the chest armor screen-match to the Battle of Falkirk sequence when Wallace was struck by an arrow and photo-matches to the film posters.

This chest armor is made of brown felt with a black canvas lining, metal plates and studs, covered in stage blood, and marked with a pinned label "STIFF METAL PLATES" on the interior. The chest armor features tears and blood splatter along the right side that correspond with the damage acquired during battle, and a blood-stained hole on the left from an arrow. This lot exhibits intentional distressing from production and minor loose material along the sides.

**Estimate: \$15,000 - 30,000**



**80**  
 William Wallace's (Mel Gibson) Leather Baldric and  
 Claymore Scabbard  
**Braveheart (1995)**

William Wallace's (Mel Gibson) leather baldric and claymore scabbard from Mel Gibson's Oscar®-winning medieval biopic Braveheart. Wallace wore his baldric to hold his claymore as he fought in the Battle of Stirling against the English soldiers.

This baldric is made of brown leather with thin leather straps for tightening and features a matching leather scabbard for a claymore sword. This lot exhibits intentional distressing from production and minor tears from age.

**Estimate: \$2,000 - 4,000**



**81**  
 William Wallace's (Mel Gibson) Arm Guard with Five  
 Arrow Tips  
**Braveheart (1995)**

William Wallace's (Mel Gibson) arm guard with five arrow tips from Mel Gibson's Oscar-winning medieval biopic Braveheart. Wallace wore his arm guard while firing arrows at Longshanks' (Patrick McGoohan) English soldiers during the Battle of Falkirk.

This lot consists of a fiberglass arm guard wrapped in brown leather featuring silver-color painted rubber studs on the front, and five silver-color painted rubber arrow tips. This lot exhibits chipping paint on the arrow tips, notable loss of adhesion on the arm guard, two missing studs exposing the fiberglass material, hardened leather from age, and a residue on the arm guard from production use. Dimensions: (tips) 2" x 1" x 0.25" (5.25 cm x 2.75 cm x 0.75 cm)

**Estimate: \$5,000 - 10,000**



**82**  
**William Wallace (Mel Gibson) and Murrón's (Catherin McCormack) Screen-Matched Bloodied Wedding Tartan**  
**Braveheart (1995)**

William Wallace (Mel Gibson) and Murrón's (Catherin McCormack) screen-matched bloodied wedding tartan from Mel Gibson's Oscar-winning medieval biopic Braveheart. The Magistrate (Malcolm Tierney) used William and Murrón's wedding tartan to clean his knife after he slit Murrón's throat for assaulting an English soldier. This tartan screen-matches to the scene where William discovered the tartan.

This red, black, and green wool tartan features a bloodied sewn straw "M" and "W" for Murrón and William with a bloodied sewn straw arabesque design to resemble flowers. The lot exhibits intentionally frayed edges and loose threads. Dimensions: 20" x 7.5" x 0.25" (51 cm x 19 cm x 0.75)

**Estimate: \$15,000 - 30,000**

**83**  
**William Wallace's (Mel Gibson) Mace**  
**Braveheart (1995)**

William Wallace's (Mel Gibson) mace from Mel Gibson's Oscar-winning medieval biopic Braveheart. Scotsman Wallace wielded his mace as he struck down an English soldier after he "surrendered" following the death of his wife Murrón.

This lot consists of a wooden mace with a long side and a shorter side with a metal connection piece in the middle. This lot exhibits extensive wear due to production use and the shorter side is chipped and intentionally distressed by production. Dimensions: 38.5" x 2" x 1.5" (98 cm x 5.25 cm x 4 cm)

**Estimate: \$3,000 - 6,000**



**84**  
**Longshanks - King Edward I's (Patrick McGoohan) Photo-Matched Sword**  
**Braveheart (1995)**

Longshanks - King Edward I's (Patrick McGoohan) photo-matched sword from Mel Gibson's Oscar-winning medieval biopic Braveheart. The imperfections on the pommel photo-match this sword Longshanks carried as he led the English soldiers in the fight against the Scottish.

This metal sword features a rounded metal pommel with a yellow acrylic gemstone and matching handguard, a red leather hand grip, and a red-painted leather wooden sheath with red leather straps and brass-color metal buckle. This lot exhibits various scuffs throughout, notable loss on adhesion on the sheath, and a loose handguard. Dimensions: 34.5" x 8.5" x 5.5" (87.75 cm x 21.75 cm x 14 cm)

**Estimate: \$8,000 - 16,000**





**85**  
**Walter White (Bryan Cranston) Costume**  
**Breaking Bad (2008-2013)**

A Walter White (Bryan Cranston) costume from Vince Gilligan's crime thriller series Breaking Bad. White wore a variety of different costumes throughout the series, both as himself and while working under his criminal alias "Heisenberg," including his green shirt, which White wore while visiting Hank Schrader (Dean Norris) after their car crash in the Season 4 episode "Crawl Space."

This costume includes a brown-beige cotton zip-front jacket hand-marked "WALT" and "WW"; a lime-green poly-nylon satin-twill button-down formal shirt (size Medium) hand-marked "WALT" and "WW"; a white cotton T-shirt (size Large) hand-marked "WALT"; beige cotton trousers (size 36/32) handmarked "WALT #1"; and beige suede boots with crepe rubber soles. Also included are five Sony Pictures Television Certificates of Authenticity. The costume exhibits signs of creasing and scuffing, with dirtied soles on the shoes and makeup staining on some of the components.

**Estimate: \$7,000 - 14,000**



**86**  
**Jesse Pinkman's (Aaron Paul)**  
**Season 1 Gas Mask**  
**Breaking Bad (2008-2013)**

Jesse Pinkman's (Aaron Paul) gas mask from Vince Gilligan's crime thriller series Breaking Bad. Pinkman and Walter White (Bryan Cranston) wore their gas masks while cooking meth throughout Season 1 before switching to more protective gear in later seasons.

This black rubber MSA Advantage 1000 respirator mask (size M) features a transparent plastic face shield, NIOSH-approved filters, and adjustable elasticated cinching straps on the back. Also included is a Sony Certificate of Authenticity. The mask exhibits grime and scuffing along the interior, and the face shield is scratched from production wear and handling.

**Estimate: \$6,000 - 12,000**

**87**  
**Walter White's (Bryan Cranston)**  
**and Jesse Pinkman's (Aaron Paul)**  
**Hazmat Suit Display**  
**Breaking Bad (2008-2013)**

Walter White's (Bryan Cranston) and Jesse Pinkman's (Aaron Paul) hazmat suit display from Vince Gilligan's crime thriller series Breaking Bad. Walt and Jesse Pinkman wore their iconic yellow hazmat suits while cooking meth throughout Seasons 3 through 5, and their distinctive 3M respirator masks with pink filters while working in Gustavo "Gus" Fring's (Giancarlo Esposito) superlab throughout Seasons 3 and 4.

These displays consist of two yellow hooded rubber and synthetic fabric zip-up hazmat suits hand-marked "Walt" and "Jesse" on the interior collars; a NIOSH-approved 3M respirator mask; and blue rubber gloves. These costumes come dressed on custom mannequins affixed with silicone Bryan Cranston and Aaron Paul heads with hand-punched synthetic hair and rolling stands. The shirts, glasses, the beanie, and the empty plastic jug labeled "Hydrofluoric acid" were replica pieces added to complete the display. The display exhibits scratching on the plastic surfaces, a buildup of grime, rips in the rubber, and some discoloration. Dimensions: (each) 48" x 24" x 76" (122 cm x 61 cm x 193 cm)

Special shipping required; see notice in the Buyer's Guide.

**Estimate: \$20,000 - 40,000**





**88**  
Bruce Lee's Vintage Boxing Gloves  
**Bruce Lee**

Bruce Lee's vintage boxing gloves. Lee wore the lace-up gloves in sparring sessions with senior instructors and students. An avid student of various fighting disciplines, he incorporated boxing into his training and martial arts philosophy.

The 8-ounce gloves are made of padded red leather and feature stitched orange leather piping around the cuffs and thumbs. Each glove has 12 eyelets into which white nylon laces are threaded in a criss-cross pattern. A label featuring the MacGregor logo and "Golden Gloves" is stitched to the wrist of each glove. Lee's initials are handwritten on the inside of the right glove.

Accompanying the gloves is a 2015 letter of authenticity from Lee's student and best friend, the late Sifu Taky Kimura. The gloves exhibit minor signs of wear, including stains and scuffs. Dimensions: (pair) 10.5" x 4.75" x 8" (27 cm x 12 cm x 20 cm)

**Estimate: \$8,000 - 16,000**



**89**  
Bruce Lee's Vintage Sunglasses  
**Bruce Lee**

A pair of Bruce Lee's vintage sunglasses. Displaying an oversized, low-profile, oval shape and an aviator style, the sunglasses became an integral part of Lee's iconic early 1970s designer chic. The frame is made of tortoiseshell plastic and the lenses are made of yellow-brown tinted glass. Dual metal rivets feature on each outer rim, connected to hinged end-pieces. The name 'France' is embossed on the inner left temple and the sunglasses are presented in a hard black plastic Dita® case. The lot is accompanied by a letter of authenticity from Lee's younger brother Robert, confirming that since receiving the sunglasses as a gift from Bruce, they had never been worn. Dimensions: 5.5" x 2" x 1.75" (14 cm x 5 cm x 4.5 cm)



**Estimate: \$8,000 - 16,000**

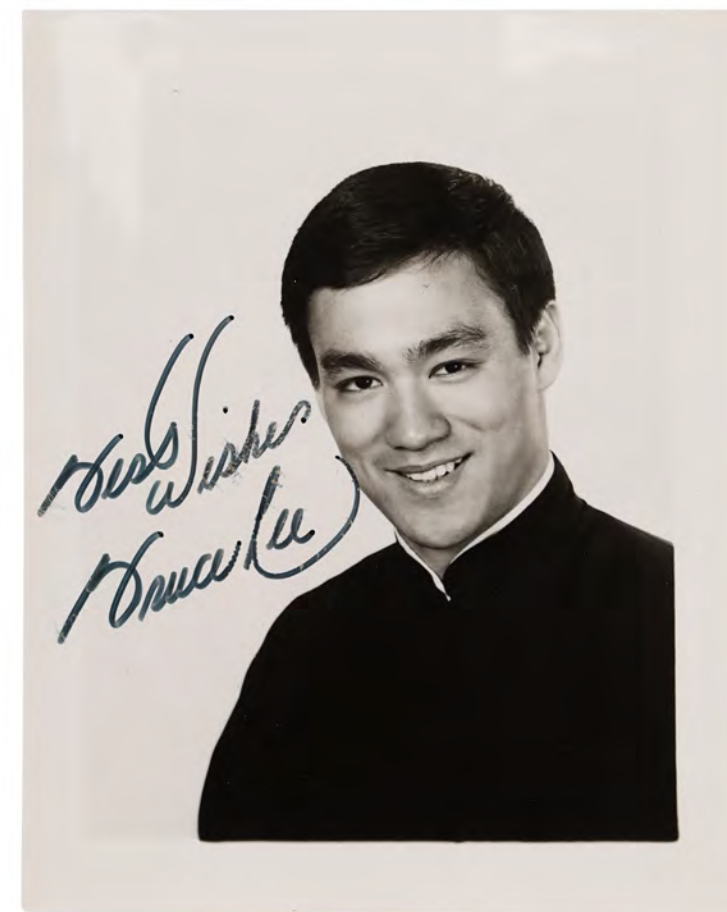

**90**  
Bruce Lee-Autographed Promotional Photo  
**Bruce Lee**

An autographed photo of Bruce Lee from the promotion of the ABC action series The Green Hornet. Lee's role as martial arts expert Kato, Britt Reid's (Van Williams) driver and crime-fighting partner, was a breakthrough for the representation of Asian-American actors on television and launched Lee to international stardom.

This black-and-white photograph featuring a smiling Lee in a black martial arts uniform with a mandarin-style button collar and white shirt collar beneath it is signed "Best Wishes Bruce Lee" in black ink. Also included is a Letter of Authenticity from Lee's best friend and student, the late Sifu Taky Kimura. Dimensions: 3.5" x 2.75" (9 cm x 7 cm)

**Estimate: \$6,000 - 12,000**

**91**  
Bruce Lee's Jeet Kune Do Grappling and Throwing Techniques Drawing  
**Bruce Lee**

A drawing by acclaimed martial artist Bruce Lee, created during the development of his revolutionary martial arts philosophy, Jeet Kune Do, or "The Way of the Intercepting Fist."

This rare, hand-drawn illustration delineates Lee's explanation of grappling and throwing techniques derived from Judo and Jiu-Jitsu. It is rendered in black and red ink on a single sheet of paper, displayed within a clear plastic cover.

The drawing depicts various body stances to correctly execute throws and to grapple, including wrist positions. It features several annotations in Lee's distinctive flowing handwriting, including "the elbow throw" and "arm drag." This lot is accompanied by a letter of authenticity detailing its history and expanding upon the technical theory. The paper exhibits yellowing from age. Dimensions: 11.5" x 9" x 0.25" (29 cm x 23 cm x 0.5 cm)

Sold without copyright; see copyright notice in the Buyer's Guide.

**Estimate: \$5,000 - 10,000**

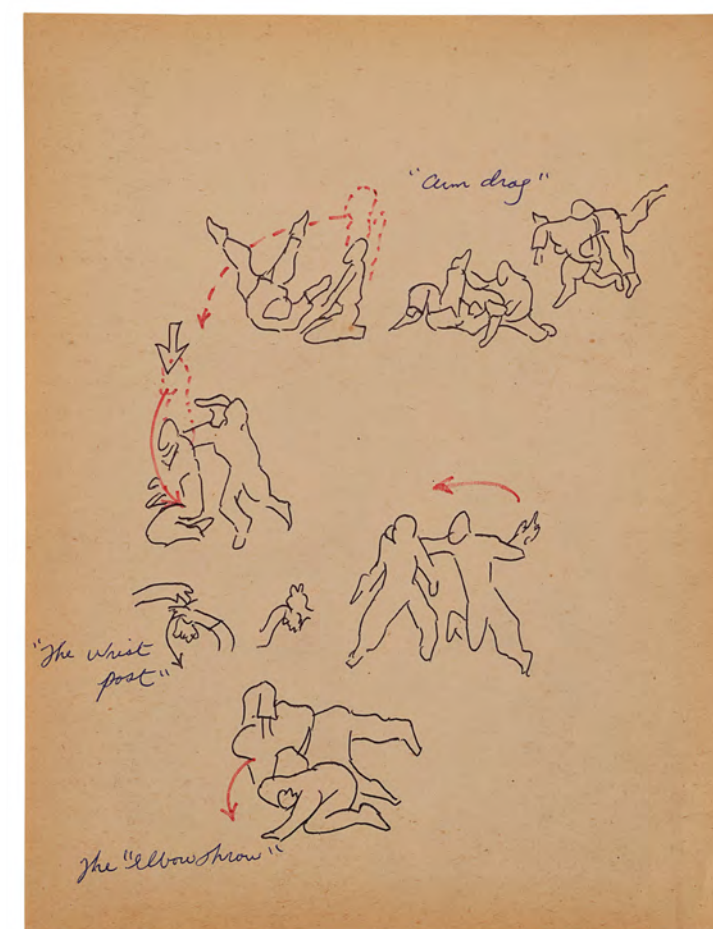

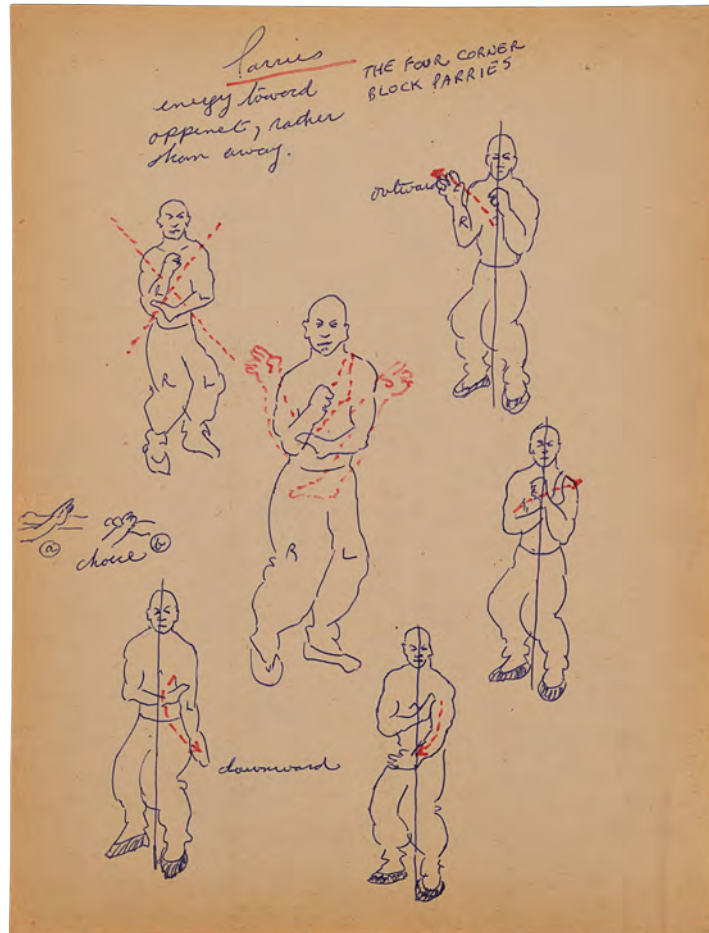

**92**  
**Bruce Lee's Jeet Kune Do Center-line Theory Drawing**  
**Bruce Lee**

A center-line theory drawing by acclaimed martial artist Bruce Lee, created during the development of his revolutionary martial arts philosophy, Jeet Kune Do, or "The Way of the Intercepting Fist". This rare hand-drawn illustration delineates Lee's explanation of the center-line theory, which propounds that a fighter should try to control an opponent's center line.

The drawing is rendered in blue and red ink on a single sheet of paper, exhibited within a clear plastic cover. It displays different hand and body positions to correctly parry an opponent's attacks. It also features several annotations in Lee's distinctive flowing handwriting, including "Parries - energy toward opponent, rather than away".

This lot is accompanied by a letter of authenticity detailing its history and expanding upon center-line theory. The paper on which the drawing is rendered has yellowed with age. Dimensions: 11.5" x 9" x 0.25" (29 cm x 23 cm x 0.5 cm)

Sold without copyright; see copyright notice in the Buyer's Guide.

**Estimate: \$5,000 - 10,000**

**93**  
**Kato's (Bruce Lee) Nunchucks**  
**The Green Hornet (1966-1967)**

Kato's (Bruce Lee) nunchucks from the ABC action series The Green Hornet. In the Season 1 episode "The Hunters and the Hunted," Kato used his nunchucks to take down a group of big game hunters targeting criminals.

This pair of 12"-long black lacquered wooden nunchucks features an eight-link metal chain and three grip grooves. Also included are seven printed black-and-white images of Lee using his nunchucks as Kato and in various photo sessions, as well as a Certificate of Authenticity from George Lee, Lee's equipment maker and personal friend, to whom these nunchucks were gifted. The COA states that Bruce Lee used them in "The Hunters and the Hunted" in 1966. These nunchucks exhibit scratches, minor chips and surface wear from production use. Dimensions: 12" x 2.5" x 1.5" (30.5 cm x 6.5 cm x 3.5 cm)

**Estimate: \$8,000 - 16,000**



**94**  
**Oz's (Seth Green) Werewolf Teeth and Costume Display**  
**Buffy The Vampire Slayer (1997-2003)**

Oz's (Seth Green) werewolf teeth and costume display from Joss Whedon's fantasy action series Buffy the Vampire Slayer. In Seasons 3 and 4, Oz's werewolf design removed the mask and utilized makeup and appliances to achieve a more humanoid werewolf face.

This display consists of a bodysuit covered in faux werewolf fur with latex hands and feet, a cowl collar, and resin werewolf fangs. The bodysuit features an opening up the back with both hook-and-eye and snap closures. It comes displayed on a custom-made poseable mannequin and stand. The lot exhibits tangled fibers and fragile latex. Dimensions: (displayed) 18" x 18" x 52" (45.75 cm x 45.75 cm x 132 cm)

**Estimate: \$4,000 - 8,000**



**95**  
**Buffy Summers' (Sarah Michelle Gellar) Love Spell Costume**  
**Buffy The Vampire Slayer (1997-2003)**

Buffy Summers' (Sarah Michelle Gellar) love spell costume from Joss Whedon's fantasy action series Buffy the Vampire Slayer. In the Season 7 episode "Him," Buffy wore her costume when star quarterback R.J. Brooks (Thad Luckinbill) put her and Dawn (Michelle Trachtenberg) under a love spell.

This costume consists of a black cotton blend button-down shirt; a black and gray plaid kilt (size 4) with black lace flowers on the ends and a 20th Century Fox wardrobe tag hand-marked "Buffy ep 6"; black and gray leatherette-tipped high heels with a Fox tag hand-marked "Buffy ep 1 p64 line30"; and a Certificate of Authenticity from the Fox Archives. The shoes exhibit fraying and cracked leather from production wear.

**Estimate: \$6,000 - 12,000**



**96**  
**Captain America's (Matt Salinger) Shield**  
**Captain America (1990)**

Captain America's (Matt Salinger) shield from Albert Pyun's superhero film Captain America. Captain America used his iconic shield in his battle against the evil Red Skull (Scott Paulin).

This round fiberglass shield features a painted pattern of a white star set on a blue field within concentric rings of red and white, and a solid white backside with two brown leather straps. The shield exhibits scuffing throughout the finish from use and age. Dimensions: 22" x 22" x 1" (56 cm x 56 cm x 2.75 cm)

**Estimate: \$8,000 - 16,000**



**97**  
**Wilson Volleyball Crew Gift**  
**Cast Away (2000)**

A Wilson volleyball crew gift from the production of Robert Zemeckis' drama Cast Away Production gifted volleyballs based on Wilson, castaway Chuck Noland's (Tom Hanks) closest companion, to cast and crew.

This ornately detailed Wilson was custom-made for a crew member and signed "A.J. Leonardi 2002" in black marker by following production by the film's stand-in painter, Tony "A.J." Leonardi. Made from white rubber, it features a dark red-painted face on the front, a jagged cut opening on the top sewn with twine, and white notched wooden sticks secured to the interior with insulation foam. Also included is a cardboard production parking placard. This volleyball is intentionally distressed, several sticks are loose, and the placard exhibits a puncture. Dimensions: 18.5" x 7.5" x 7.5" (47 cm x 19 cm x 19 cm)

**Estimate: \$10,000 - 20,000**

**98**  
**Screen-Matched Hero Good Guy Doll**  
**Cult Of Chucky (2017)**

A screen-matched hero Good Guy doll from Don Mancini's horror sequel Cult of Chucky. Chucky (Brad Dourif) possessed the body of a Good Guy doll to continue his murderous rampage through the psychiatric hospital and expand his cult. This doll screen-matches to several scenes throughout the early part of the film.

Created by effects studio Alterian Inc., this doll's print pattern and facial imperfections match up to several scenes. It features a vinyl head and hands painted a flesh-tone with hand-painted eyelashes and freckles; a glued-on red synthetic wig; blue urethane eyes; and a polyfill filled-cloth body. It is dressed with custom-made clothing, including a colorful, striped long-sleeve knit top; a dungaree featuring a toy print pattern; red socks; and red and white vinyl shoes. Both the front pocket on the dungarees and the shoelaces display the doll's brand name, "Good Guys." This doll exhibits some matting of the synthetic hair and imperfections from the production process. Dimensions: 30" x 13" x 8" (77 cm x 33 cm x 20 cm)

**Estimate: \$20,000 - 40,000**



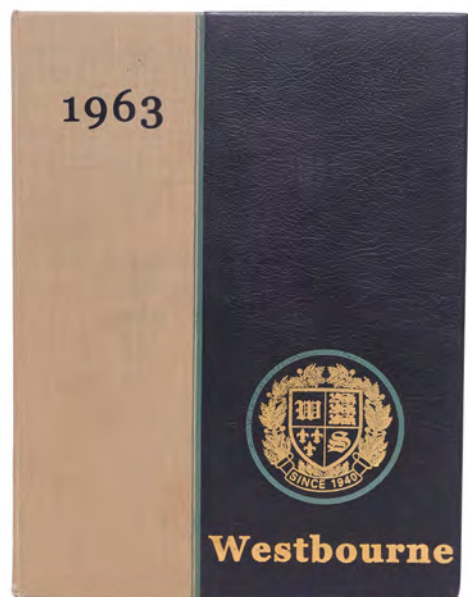

**99**  
 Frank Abagnale, Jr.'s (Leonardo DiCaprio) Screen-Matched  
 1963 Yearbook  
**Catch Me If You Can (2002)**

Frank Abagnale, Jr.'s (Leonardo DiCaprio) screen-matched 1963 yearbook from Steven Spielberg's biographical crime film *Catch Me If You Can*. FBI Agent Carl Hanratty (Tom Hanks) recognized Abagnale's school picture in his yearbook. Small stains and scuffs on Abagnale's page, the previous page, and along the edge of the back cover match to a close-up shot of the open yearbook in the film.

This yearbook features a blue leatherette and gray woven fiber cover with gold-color writing including the year "1963," the school name "Westbourne," and a school crest. Inside are black-and-white yearbook pages including one "Tenth Grade" page with a picture of a young Abagnale labeled "Frank Abagnale Jr." It exhibits some wear from use and age, including corner denting. Dimensions: 9" x 11.5" x 0.5" (23 cm x 29.25 cm x 1.5 cm)

**Estimate: \$2,000 - 4,000**

**100**  
 Christine "Plymouth" Hood Badge  
**Christine (1983)**

A Christine "Plymouth" hood badge from John Carpenter's adaptation of Stephen King's supernatural horror *Christine*. Arnie Cunningham (Keith Gordon) purchased Christine, a 1958 Plymouth Fury, with the desire to fix it up, but Christine had other, darker intentions.

This aluminum screw-on badge with "PLYMOUTH" stamped between its two wings and serial number "EMD1754317" stamped on the reverse was rescued from a scrap heap in Fontana, California after the release of the film in 1983. Also included is a custom-made display stand. The badge exhibits some grime, rusting, and discoloration from exposure and age. Dimensions: (displayed) 2.75" x 21" x 8" (7 cm x 53 cm x 20 cm)

**Estimate: \$8,000 - 16,000**

**101**  
 Christine's License Plate, Key, and Two Production  
 Photos  
**Christine (1983)**

Christine's license plate, key, and two production photos from John Carpenter's adaptation of Stephen King's supernatural horror *Christine*. Arnie Cunningham (Keith Gordon) purchased Christine, a 1958 Plymouth Fury, with the desire to fix it up, but Christine had other, darker intentions.

This lot consists of a yellow plastic California license plate with black lettering reading "CQB 241" and "56"; a metal key believed to be a house key attached to a white and orange plastic Victor keychain, and two color photos of the car hand-marked "SC 78-79" and "LeBay's Sc 18pt, 19, 20, 21" respectively. The plate exhibits minimal chipping to its finish and adhesive residue on the back; the keychain exhibits scuffing and staining; and the photos exhibit staining, crumpling to the borders, and tears in the back. Dimensions: (largest) 12" x 6" x 0.25" (30.5 cm x 15.25 cm x 0.75)

**Estimate: \$4,000 - 8,000**



**102**  
 Perseus' (Sam Worthington) Sword of the Gods  
**Clash Of The Titans (2010)**

Perseus' (Sam Worthington) Sword of the Gods from Louis Leterrier's fantasy-adventure remake *Clash of the Titans*. The blade of Perseus' sword, which was imbued with the magical power of Olympus, emerged whenever he battled through ancient Greece.

This dense rubber version of the broadsword was created for fight sequences where the blade was already extended. It is hand-painted silver-color and engraved down the center with runes of the Gods hunting alongside Apollo's chariot and down the handle with criss-cross patterns. The sword exhibits cracked rubber and paint flaking throughout from use and age. Dimensions: 33.25" x 2.75" x 1.25" (84 cm x 7 cm x 3 cm)

**Estimate: \$2,000 - 4,000**

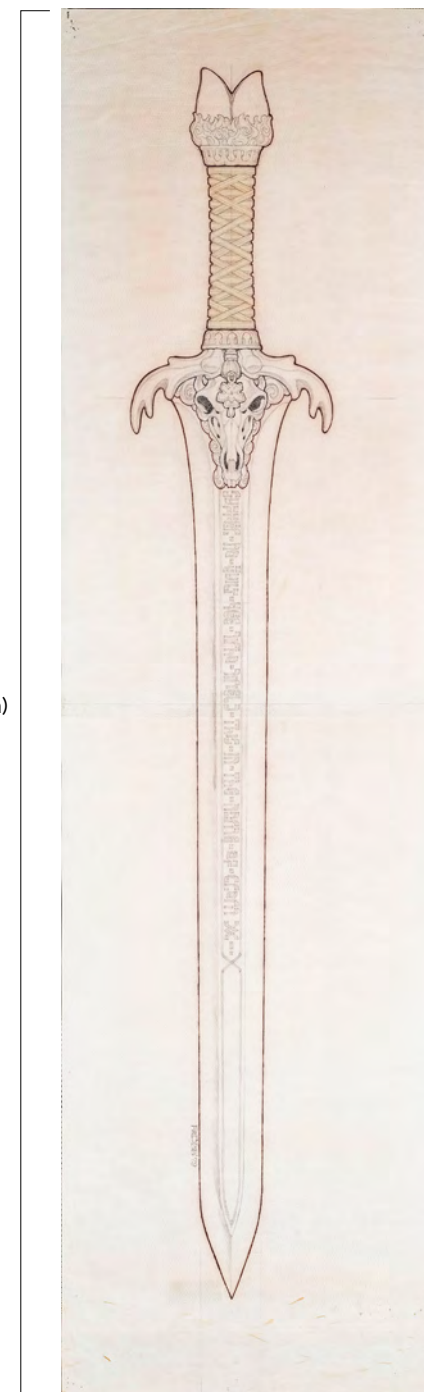

43.5" (110.5cm)

**103**  
 Hand-Drawn Ron Cobb Father's Sword Concept  
 Sketch  
**Conan The Barbarian (1982)**

A concept sketch of Conan's (Arnold Schwarzenegger) father's sword hand-drawn by production designer Ron Cobb for John Millius' fantasy epic *Conan the Barbarian*. To avenge his people, Conan reclaimed remnants of the sword his father (William Smith) crafted before Thulsa Doom (James Earl Jones) raided their Cimmerian village.

This full-length, ornately detailed sketch of the sword is rendered in pencils and inks across two sheets of illustration paper adhered together. "Suffer No Guilt Yee Who Wield This in the Name of Crom" is written along the blade in stylized text, and one sheet is signed and dated "79" by Cobb. The sketch exhibits pinholes at the edges, creasing, multicolor stains, and minor discoloration from age. Dimensions: 43.5" x 12" (110.5 cm x 30.5 cm)

Sold without copyright; see notice in the Buyer's Guide.

**Estimate: \$4,000 - 8,000**



**104**  
Animatronic Krite Puppet  
**Critters (1986)**

An animatronic Krite puppet from Stephen Herek's cult sci-fi horror film Critters. After landing in a small farming town, small aliens terrorized the citizens by trying to eat them.

Created by the Chiodo Brothers, this lot consists of one puppet. Made of foam latex with rubber teeth, acrylic eyes, and hand applied faux fur, this puppet features hollow fiberglass armatures, internal wires, and an open back. This puppet has been mounted on a pipe and board for display purposes. This lot exhibits flaked paint, cracking and hardening to the foam, aged latex, and some fragility. Dimensions: 14" x 17" x 10" (35.5 cm x 43.25 cm x 25.4 cm)

Contains electronics; see electronics notice in the Buyer's Guide.

Contains mechanical components; see notice in the Buyer's Guide.

**Estimate: \$5,000 - 10,000**



**105**  
Critter Puppet Display  
**Critters 4 (1992)**

A Critter puppet display from Rupert Harvey's sci-fi sequel Critters 4. The crew of the RSS Tesla battled Critters aboard a space station in the year 2045, including the final Critter they zapped on the head, flash-froze, and ultimately exploded.

Created for scenes before the flash-frozen Critter shattered, this foam latex puppet features painted blue skin, pink gums, multiple rows of yellowed teeth, hand-punched gray synthetic fur, and red plastic eyes, all mounted to a black wooden display base. The top of its head is smeared with blue flash-freezing "slime," and additional slime residue is scattered throughout the fur. This puppet underwent sympathetic restoration following production, including having its eyes re-opened, and the foam latex exhibits chipping from age. Dimensions: 14" x 11" x 21" (35.75 cm x 28 cm x 53.5 cm)

**Estimate: \$8,000 - 16,000**



**106**  
Bai Ling-Autographed Screen-Matched Light-Up SFX  
Blinded Myca Head Display  
**The Crow (1994)**

A screen-matched light-up SFX blinded Myca (Bai Ling) head display from Alex Proyas' action fantasy The Crow. Slashes on this head's cheeks screen-match to when Eric Draven's (Brandon Lee) crow gouged Myca's eyes out in the climactic finale.

One of several heads built by SFX makeup artist Lance Anderson's team to portray various stages of Myca's disfigurement, this head features hand-painted rubber skin applied over a foam core, hand-punched synthetic hair, a red suede hood with metal rivets, and a hole near the left eye for projecting blood. It comes mounted via a chrome rod to a custom-made illuminating base engraved "Bai Ling SFX Head" and signed "I love the pretty eyes" in silver-color ink by Ling. The head exhibits cracking rubber, paint flaking, and loose hairs from age and exposure. Dimensions: 8" x 10" x 17" (20.5 cm x 25.5 cm x 43.25 cm)

Contains electronic components; see notice in the Buyer's Guide.

**Estimate: \$4,000 - 8,000**



**107**  
Terrorist Team's Kenwood Radio  
**Die Hard (1988)**

The terrorist team's Kenwood radio from John McTiernan's action thriller Die Hard. This style of radio was used by Hans Gruber (Alan Rickman) and other members of the terrorist team, as well as John McClane (Bruce Willis) throughout the film.

This lot consists of a Kenwood TH-21BT two-way radio. Composed of a plastic body, buttons and screw-on aerial, this radio features a detachable battery, four battery screws, three antennae, and a charger. It also features a hand-cut white Kenwood logo label on the back so the logo would remain visible at all times. Also included is a letter of authenticity from the weapons handler and assistant property master Mike Sudrow. This lot exhibits scratching and discoloration. Dimensions: 8" x 5" x 3" (20.5 cm x 12.75 cm x 7.75 cm)

Contains electronics; see electronics notice in the Buyer's Guide.

**Estimate: \$4,000 - 8,000**

**108**

### Batman's (Christian Bale) Batpod The Dark Knight (2008)/The Dark Knight Rises (2012)

Batman's (Christian Bale) iconic Batpod from Christopher Nolan's sci-fi action films The Dark Knight and The Dark Knight Rises. In The Dark Knight, Batman used his signature bat-inspired Batpod to escape his Tumbler during his battle with the Joker (Heath Ledger) in an unsuccessful attempt to save Rachel Dawes (Maggie Gyllenhaal) and Harvey Dent (Aaron Eckhart). Later, in The Dark Knight Rises, Batman and Selina Kyle (Anne Hathaway) used the Batpod during their battles with Bane (Tom Hardy) and the new League of Shadows.

Among the most recognizable, genre-defining vehicles in cinema history, the Batpod was conceived by Nolan and designed by production designer Nathan Crowley as a sleeker alternative to Batman's trusty Tumbler. The hi-tech vehicle was then brought to life by special effects supervisor Chris Corbould, who made six of them for production on The Dark Knight. This unique Pod is designed for a rider in a prone position to steer with their arms and shoulders, and features advanced design elements, such as an exhaust system integrated within the framework. The Batpods were largely driven by stunt rider Jean-Pierre Goy during filming, and used for numerous events in the promotion of The Dark Knight and The Dark Knight Rises. Crowley received Academy Award® and BAFTA Award® nominations for his work on The Dark Knight. Batman's Batpod has been on loan since 2017 from its private owner to the world-renowned Petersen Automotive Museum in Los Angeles, CA, where it was displayed alongside some of the most historic vehicles ever created, such as the DeLorean from Back to the Future, the Tesla Cybertruck, and the world's first-ever motorcycle and automobile. It has also featured prominently in the Hollywood Dream Machines exhibit since 2019 and in the museum's Private Vault for VIP tours.

It features a custom-made chassis with 31" Hoosier racing tires and a Honda 750 engine; fiberglass body panels covering the engine and handlebars finished in metallic gray paint; two plastic, resin, and fiberglass cannon barrels secured to the front of the vehicle; and a laser targeting unit fitted above the right-hand grip. A radiator and hydraulics are fitted behind the saddle, and the braking system is operated by controls on the left handle and the right pedal. Black foam padding is installed on the body, saddle, and knee rests for comfort.

This lot includes a Certificate of Authenticity from Warner Bros. Well-used on both productions, as well as in their promotion as part of the Warner Bros. archive, this Batpod exhibits some wear to the body panels and some light corrosion on the chassis, with damage to the left gun mount as a result of use on set. The vehicle is supplied with a metal support stand for display purposes. Dimensions: 149.5" x 47.25" x 42.25" (380 cm x 120 cm x 107 cm)

Payment plans are not available for this lot.

Contains mechanical components; see notice in the Buyer's Guide.

Special shipping required; see notice in the Buyer's Guide.

**Estimate: \$1,000,000 - 2,000,000**



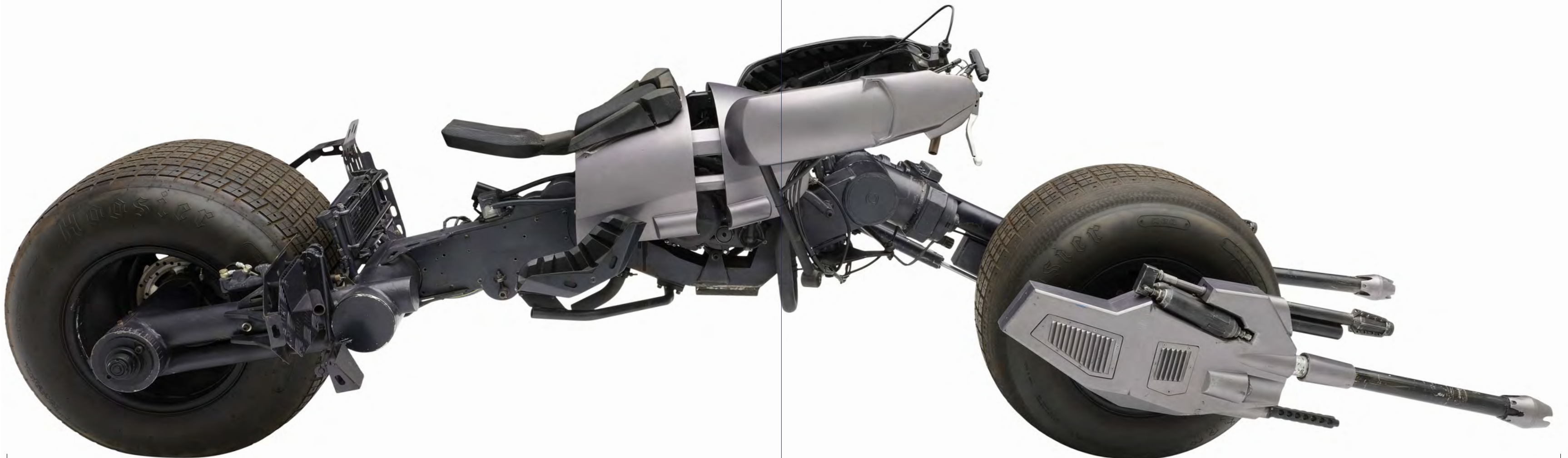
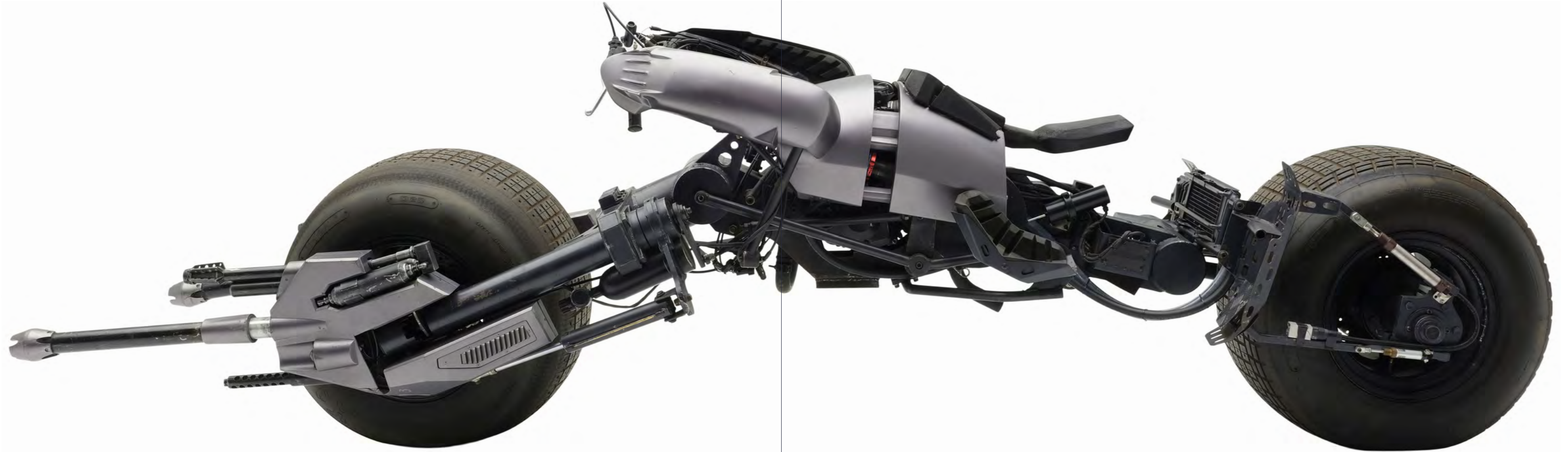

12.5' (3.8m)





Page from *The Dark Knight Manual*

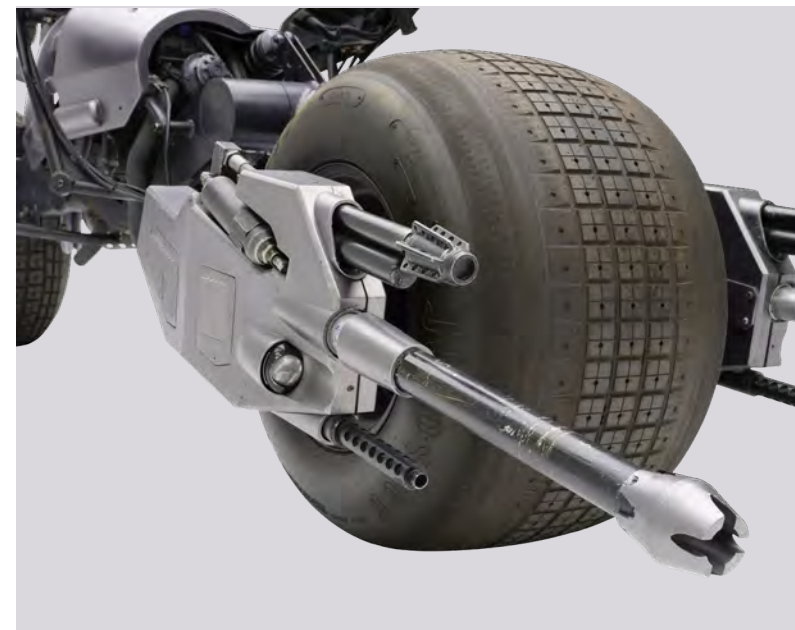

**109**  
**Mechanical Mystic Walking Puppet Head**  
**The Dark Crystal (1982)**

A mechanical Mystic walking puppet head from Jim Henson and Frank Oz's fantasy film *The Dark Crystal*. The wise and peaceful race known as the Mystics held a spiritual link with their evil counterparts, the Skeksis.

This head features a fiberglass skull covered in foam latex skin with brown glass eyes, hand-punched hair and eyebrows, and a mesh hood on the back. Inside the skull are puppetry mechanisms including a still-functional blinking mechanism designed to allow a single puppeteer to operate it while walking.

The head is mounted to a black wooden base for display. It exhibits wear from use and age, including the extensive drying and crumbling of the foam latex skin, but what remains of the latex has been professionally sealed. Dimensions: 16.75" x 12.75" x 14" (42.75 cm x 32.5 cm x 35.75 cm)

Contains mechanical components; see notice in the Buyer's Guide.

**Estimate: \$8,000 - 16,000**



**110**  
**Framed Published Hand-Drawn Brian Froud Mystics**  
**Concept Artwork**  
**The Dark Crystal (1982)**

Framed concept artwork of the Mystics hand-drawn by Brian Froud from the production of Jim Henson and Frank Oz's fantasy film *The Dark Crystal*. The wise and peaceful race known as the Mystics held a spiritual link with their evil counterparts, the Skeksis.

This concept artwork, rendered in pencil on drawing paper and lightly marked "A/W 79" in the top left corner, was previously published in Froud's book *The World of The Dark Crystal*. It comes framed with a tan canvas mat in a black frame with a hanging wire on the back. The drawing exhibits some light staining. Dimensions: 20.5" x 25.5" x 1" (52 cm x 65 cm x 2.75 cm)

Sold without copyright; see notice in the Buyer's Guide.

**Estimate: \$2,500 - 5,000**



**111**  
**John McClane's (Bruce Willis) Bloodied Costume**  
**Die Hard With A Vengeance (1995)**

John McClane's (Bruce Willis) bloodied costume from John McTiernan's action-thriller sequel *Die Hard With A Vengeance*. McClane's clothing was progressively damaged and blood-stained as he and Zeus Carver (Samuel L. Jackson) attempted to stop terrorist Simon Gruber (Jeremy Irons) from robbing the Federal Reserve.

This costume consists of a ribbed white cotton tank, a pair of khaki chinos, and a paramedic patch. The tank top and chinos were heavily distressed by production to appear blood-stained and covered in grime, and the patch was distressed to also appear covered in grime. The included patch is from later scenes after McClane and Carver are recovered by Coast Guard paramedics, and McClane is given a jacket featuring a patch like this. Also included is a production wardrobe tag hand-labeled "The ending" for "Sc 226 McClane." The tank exhibits some stretching to the fabric and frayed threads on the chinos.

**Estimate: \$5,000 - 10,000**



**112**  
**Disney-Owned 35mm Mitchell BNCR Camera**  
**Disney Studios**

A 35mm Mitchell BNCR camera owned by Disney Studios. This updated Mitchell BNCR camera featuring blimp housing for sound-shooting and a lens mount for the reflex viewer so operators could view action through the lens while filming was sold to Disney in May 1955, then converted to Reflex in 1969.

Composed primarily of metal and plastic, it features engraved labels for audio plug-ins and visual input; housing for a dummy lens; and a plaque with serial number "BNCR-163 E-3482." The camera's internals are in good overall condition and complete, and it still maintains its original paint finish with "BNC 325" stenciled in white on the magazine. A metal "Cinema Product Development" plaque on the side is for a boxy motor, which was added to the camera later on. Also included is a wood tripod and a Worrall geared head, though the head exhibits damage and requires work to stay intact as a unit. The lot also exhibits chipped paint, grime, and fragile components. Dimensions: 48" x 24" x 14" (122 cm x 61 cm x 35.5 cm)

Contains electronics and mechanical components; see notice in the Buyer's Guide. Special shipping required; see notice in the Buyer's Guide.

**Estimate: \$4,000 - 8,000**

**113**  
**Walt Disney's Enchanted Tiki Room Fountain Shield**  
**Disneyland Park**

A fountain shield from Walt Disney's Enchanted Tiki Room at Disneyland. Since its opening in 1963, the centerpiece of the pioneering audio-animatronic musical attraction has been the "magic fountain," which has featured decorative tiki shields on each of its corners.

This fiberglass shield depicting a tiki character sticking its tongue out is cast from a sculpt by Imagineer Rolly Crump and hand-painted to simulate carved wood with yellow, blue, red, and white embellishments. Also included is a Certificate of Authenticity from Van Eaton Galleries. The back is unpainted and exhibits holes and scuffing from where it was mounted, and the fiberglass exhibits some cracking near the top. Dimensions: 19.5" x 5" x 50" (49.75 cm x 12.75 cm x 127 cm)

Special shipping required; see notice in the Buyer's Guide.

**Estimate: \$30,000 - 60,000**



Helen Sessions / Alamy Stock Photo





**114**  
**Figment Animatronic Character Skin from EPCOT's Journey Into Imagination Walt Disney World**

Figment animatronic character skin from EPCOT's Journey Into Imagination in Walt Disney World Resort. The first iteration of the attraction was open from 1983 to 1998 and starred Dreamfinder (voiced by Chuck McCann) and a purple dragon named Figment (originally voiced by Billy Barty). It is believed that the piece was initially created for use in the attraction or its video segments, and later used as a color and sculpture reference for an ultimately unmade Dreamfinder television series.

This lot consists of the cast vinyl skin for the upper body of a Figment figure, hand-painted purple and pink with brown horns and yellow eyes. The flexibility of the hollow vinyl skin would have allowed for puppeteering, either by hand or audio animatronics. Also included are a wooden display base and a Certificate of Authenticity from Van Eaton Galleries. The skin exhibits discoloration and paint chipping, with tearing around the underarms and where the horns connect. Dimensions: 9" x 9" x 20" (23 cm x 23 cm x 51 cm)

**Estimate: \$20,000 - 40,000**



**115**  
**Framed Hand-Painted Maggie Parr "Pinky Daisy" Painting Disneyland Park**

A framed painting titled "Pinky Daisy" hand-painted by Walt Disney Imagineer Maggie Parr. Parr contributed design work to Disney's many theme parks, including Disneyland's Toontown and Walt Disney World's Animal Kingdom.

This 2007 painting of Daisy Duck in front of The Magic Kingdom is rendered and signed by Parr in oil on canvas. It comes mounted with a gold-color painted wooden frame affixed with a hanging wire. Included is a Disneyland Resort Certificate of Authenticity. The frame's paper backing exhibits several punctures. Dimensions: 34" x 40" x 3.5" (86.5 cm x 101.75 cm x 9 cm)

Sold without copyright; see notice in the Buyer's Guide.

**Estimate: \$4,000 - 8,000**



**116**  
**Framed Hand-Painted Maggie Parr "Blue Duck" Painting Disneyland Park**

A framed painting titled "Blue Duck" hand-painted by Walt Disney Imagineer Maggie Parr. Parr contributed design work to Disney's many theme parks, including Disneyland's Toontown and Walt Disney World's Animal Kingdom.

This 2007 painting of Donald Duck in a gentlemanly blue costume is rendered and signed by Parr in oil on canvas. It comes mounted to an ornate wooden frame affixed with a hanging wire. Also included is a Disneyland Resort Certificate of Authenticity. The canvas exhibits minor scratches and the frame exhibits some stains. Dimensions: 42" x 36" x 5" (106.75 cm x 91.5 cm x 12.75 cm)

Sold without copyright; see notice in the Buyer's Guide.

**Estimate: \$4,000 - 8,000**



**117**  
**Disneyland Grand Opening Commercial Scripts and Handwritten Note**  
**Disneyland Park**

Disneyland grand opening scripts and a handwritten note from Disneyland Park. These scripts were used during the grand opening of the theme park in 1955 for three commercials.

This lot consists of three sets of two-page commercial used scripts with handwritten annotations within a gold-color wooden frame featuring a gold-color plaque engraved "Disneyland Park Grand Opening July 17, 1955"; and one handwritten note by previous owner Rosie Herald stating the scripts came from the collection of a former Disney Studios employee displayed in a red wooden frame. This lot exhibits minor scuffs to the frames. Dimensions: 32.5" x 22.5" x 1.75" (82.75 cm x 57.25 cm x 4.5 cm)

**Estimate: \$1,500 - 3,000**



**118**  
**Hand-Drawn Roy Alexander Poster Concept Artwork**  
**One Hundred And One Dalmatians (1961)**

Concept artwork for a poster for Walt Disney Productions' animated classic One Hundred and One Dalmatians hand-drawn by marketing illustrator and Walt Disney Studios VP of Creative Services Roy Alexander. Created as a comp for a potential one-sheet, this artwork depicting Cruella de Vil, Jasper, and Horace chasing the eponymous spotted dogs is rendered in felt-tip markers on vellum taped to bond paper. It exhibits creasing from being rolled for storage and some ink splotches in the margins. Dimensions: 19" x 24" (48.25 cm x 61 cm) Sold without copyright; see notice in the Buyer's Guide.

**Estimate: \$1,000 - 2,000**

**119**  
**Replica TARDIS Police Box Used for Various Non-BBC Productions**  
**Doctor Who (2005)**

A replica TARDIS police box based on the 11th and 12th Doctors' configuration from Steven Moffat's sci-fi series Doctor Who. The Doctor (Matt Smith and Peter Capaldi) sought adventure through time and space with various human companions and outsmarting countless nemeses, including Daleks and the Weeping Angels.

This replica was used in a variety of trade shows and rented out to various non-BBC productions, including The Late Late Show with Craig Ferguson, and is constructed for fast setup and striking as needed. Built primarily from spruce wood and painted "Sydney Blue" to emulate the original production pieces, it features light and sound options that are remote controllable. Its light-up functions include the top-mounted lantern, in addition to various acrylic signages: "Police Box" headers, windows, and the "Pull to Open" door sign with hand-applied acrylic lettering. A speaker allows for the audio playback of key effects, including the iconic TARDIS "Vwoorp!" materialization and dematerialization, the Cloister Bell catastrophe alarm, and the door lock's "chirp chirp." Light and sound effects are coordinated, depending on pre-programmed remote-controlled instructions. The instruction manual detailing assembly, takedown, and functionality, as well as a radio-control remote and power source, is included. The display exhibits scratches, nicks, grime, scuffs, and wear at the panel connections. Dimensions: 60" x 60" x 122 (152.5 cm x 152.5 cm x 310 cm)

Contains electronics; see electronics notice in the Buyer's Guide.

Special shipping required; see notice in the Buyer's Guide.

**Estimate: \$15,000 - 30,000**





**120**  
 Luke (Tom Wopat) and Bo Duke's (John Schneider) License Plate  
**The Dukes Of Hazzard (1979-1985)**

Luke (Tom Wopat) and Bo Duke's (John Schneider) license plate from the action comedy series *The Dukes of Hazzard*. The Duke boys' drove their iconic 1969 Dodge Charger, with its Hazzard County license plate, throughout the series.

This metal license plate features a cream-color face with green lettering reading "CNH 320" and decals reading "76," "83," and "Hazzard County." It exhibits denting, paint chipping, and discoloration to the metal. Dimensions: 12" x 6" x 0.25" (30.5 cm x 15.25 cm x 0.75 cm)

**Estimate: \$6,000 - 12,000**



**121**  
 Framed Steven Spielberg-Autographed "Touching  
 Fingers" One-Sheet  
**E.T. The Extra-Terrestrial (1982)**

A framed "touching fingers" one-sheet from the promotion of Steven Spielberg's sci-fi classic *E.T. the Extra-Terrestrial* autographed by Spielberg. The iconic "touching fingers" posters inspired by Michelangelo's "The Creation of Adam" were designed by posterist John Alvin, who used his daughter's hand as a model for E.T.'s as it touched Elliott's (Henry Thomas).

This original, full-color one-sheet with the tagline "His Adventure on Earth" is autographed "To Steve, E.T. & Me Owe You a Lot" in white by Spielberg for a crew member shortly after the film's release. It comes mounted behind glass in a black wooden frame affixed with a hanging wire on the reverse. The poster exhibits minor creasing along its top edge. Dimensions: 33" x 47" x 1" (84 cm x 119.5 cm x 2.5 cm)

**Estimate: \$2,500 - 5,000**



**122**  
 Rita Vrataski's (Emily Blunt) Blade  
**Edge Of Tomorrow (2014)**

Rita Vrataski's (Emily Blunt) blade from Doug Liman's sci-fi action film *Edge of Tomorrow*. Vrataski, the "Angel of Verdun," carried her sword on the battlefield during Cage's (Tom Cruise) first day of combat and became the poster girl for the war, frequently pictured with the unique weapon of choice.

The weapon is made of a black-painted urethane in the shape of a helicopter tail rotor blade with foil fixed along the narrow edge of the blade to resemble sharpened metal. A distressed UDF sticker near the hilt includes information on the fictional vehicle it originated from and a range of alphanumeric digits are spray-painted further along in pale brown. The hilt is partially wrapped in black electrical tape, with brown paint applied simulating mud and grime. The pommel is painted metallic gray and the blade includes a line of red spray paint across the tip. This lot exhibits intentional production distressing, including chips to the foil. Dimensions: 48" x 6.25" x 2.5" (122 cm x 16 cm x 6 cm)

**Estimate: \$30,000 - 60,000**



**123**  
**Edward Scissorhands'**  
**(Johnny Depp) Scissor Hand**  
**Set with Screen-Matched**  
**Retractable Blades**  
**Edward Scissorhands (1990)**

Edward Scissorhands' (Johnny Depp) scissor hand set with screen-matched retractable blades from Tim Burton's fantasy romance Edward Scissorhands. Created by a visionary inventor (Vincent Price), Edward used his iconic bladed hands throughout the film, including to woo Kim (Winona Ryder), the girl he loved. Surviving examples of retractable blades are rare, and the mechanical details of the particular retractable blades in this lot screen-match to the SFX close-up insert of Edward stabbing Jim (Anthony Michael Hall) in their climactic confrontation.

This incomplete set was assembled from original production components. The right hand consists of two metal and resin retractable SFX stabbing blades with urethane handles painted black and red, as well as resin thumb and pinky blades painted silver-color. The left hand consists of four urethane blades and one resin blade with a serrated metal edge applied throughout with foil and painted red, black, and silver.

The bladed fingers and copper- and silver-color rubber hand-backs are mounted to display hands reinforced with wire, painted black at the wrists, stuffed with foam for structure, and dressed with black velour gloves. The blades exhibit notable points of chipping paint, pieces loosening, and the index and middle finger blades of the left hand utilize right-hand style blades. Dimensions: 21" x 9" x 5" (53.5 cm x 23 cm x 12.75 cm)

**Estimate: \$50,000 - 100,000**



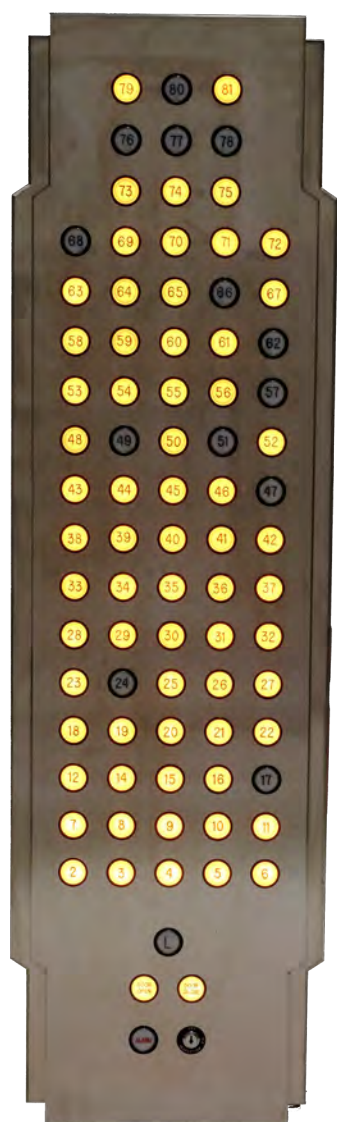

**124**  
**Light-Up Empire State Building Elevator Button Panel**  
**Elf (2003)**

A light-up Empire State Building elevator button panel from Jon Favreau's Christmas movie Elf. After he witnessed an elevator button lighting up, Buddy (Will Ferrell) was overcome with excitement and pushed every button to light more up.

Custom-made by SPFX Coordinator Tony Lazarowich's team, this lot consists of a metal elevator panel with working buttons and individual plugs and cables rigged to each light. The back bottom of the panel features a written label for "Tony SFX." The panel requires a 12V car battery to operate the lights. This lot exhibits burnt out bulbs in buttons 80, 76, 78, 49, 51, 24, 17, L, and Alarm. Dimensions: 15" x 51.5" x 3" (38.25 cm x 131 cm x 7.75 cm)

Contains electronics; see electronics notice in the Buyer's Guide.

Special shipping required; see notice in the Buyer's Guide.

**Estimate: \$15,000 - 30,000**



**125**  
**Santa's (Ed Asner) Light-Up Scaled Sleigh Dashboard with Spirit**  
**Clausometer**  
**Elf (2003)**

Santa's (Ed Asner) light-up, scaled sleigh dashboard with a Spirit Clausometer from Jon Favreau's Christmas movie Elf. Jovie (Zooey Deschanel) started a sing-along to raise the Clausometer on Santa's sleigh after Buddy (Will Ferrell) lost his Christmas spirit.

This dashboard was custom-made by the SFX team for shots of the fully-operational sleigh at a smaller scale in order to make Buddy appear oversized. It features a panel of chrome-plated buttons and gauges, including a "Spirit Clausometer," a pressure gauge, and buttons labeled "Ho Ho Ho," inset into a polished wooden compartment. Following production, electronics on the reverse were switched out by SFX crew with a more automated system which illuminates buttons and raises gauges when connected to an AC outlet. Several lights are dimming and the wood exhibits scratches from production use. Dimensions: 23" x 7" x 11" (58.5 cm x 18 cm x 28 cm)

Contains electronic components; see notice in the Buyer's Guide.

**Estimate: \$10,000 - 20,000**



**126**  
**Buddy's (Will Ferrell) SFX**  
**Jack-in-the-Box**  
**Elf (2003)**

Buddy's (Will Ferrell) SFX Jack-in-the-Box from Jon Favreau's Christmas movie Elf. Buddy tested frightening Jack-in-the-Box toys in Santa's (Ed Asner) workshop. One of them later appeared on Santa's sleigh.

This Jack-in-the-Box was customized with an internal remote-firing system by the SFX team to control the padded felt Jack's launch time during the workshop and sleigh scenes. The Jack comes inside a colorful tin box affixed with a red-topped crank which operates a music box on the interior. Due to its adjustments, the lid must be lifted for the Jack to launch, and the remote-firing mechanism was removed following production. The box exhibits scratching and scuffing around its edges from use. Dimensions: 6" x 6" x 6.5" (15.25 cm x 15.25 cm x 16.5 cm)

Contains mechanical components; see notice in the Buyer's Guide.

**Estimate: \$4,000 - 8,000**



6" (1.83m)

**127**  
**Snake Plissken's (Kurt Russell) Escape Sub Model Miniature**  
**Escape From L.A. (1996)**

Snake Plissken's (Kurt Russell) escape sub model miniature from John Carpenter's Escape from L.A. Plissken maneuvered his escape sub as he traveled underwater to the L.A. island to recover a top secret briefcase.

This model miniature is made of a black-painted resin body and metal side barrels. The model miniature features a hook at the top end that allows the model to be secured as it is submerged in water and is weighted to stay underwater. This lot exhibits paint chipping on the front and sides exposing the material and a crack along the underside. Dimensions: 72" x 16" x 8" (183 cm x 40.75 cm x 20.5 cm)

Special shipping required; see notice in the Buyer's Guide.

**Estimate: \$5,000 - 10,000**



**128**  
**Stop-Motion Henrietta Knowby**  
**(Ted Raimi) Worm Head**  
**Evil Dead II (1987)**

A stop-motion Henrietta Knowby (Ted Raimi) worm head from Sam Raimi's horror sequel Evil Dead II. Ash Williams (Bruce Campbell), trapped in the fruit cellar beneath the Knowbys' cabin, quickly found himself face to face with the Deadite form of Henrietta Knowby as her head burst up through the floor with worms wiggling out from her flesh.

This lot consists of a foam head featuring green-painted skin with red detailing, white eyes, white hair, and foam worms with wire armatures sticking out from the forehead. The head is mounted on a white plastic pipe. The foam exhibits hardening and cracking from age, while the finish exhibits some paint loss and discoloration. Dimensions: 18" x 4" x 5" (45.75 cm x 10.25 cm x 12.75 cm)

**Estimate: \$5,000 - 10,000**





**129**  
**Moses' (Christian Bale) Battle Armor Costume**  
**Exodus: Gods And Kings (2014)**

Moses' (Christian Bale) battle armor costume from Ridley Scott's biblical epic Exodus: Gods and Kings. Moses wore his full armor costume while fighting alongside Ramses (Joel Edgerton) in the battle against the Hittite army.

The costume consists of a blue resin helmet with a flocked interior; a black fabric hood; a yellow muslin scarf; a paneled metal collar with leather cord trim; a black leather tunic with attached shoulder armor and sleeves; metal bracers; two leg armor panels and a back armor panel all attached to a brown belt (not production-used); a gray woven fabric undershirt; and black leather greaves. Included are brown lace-up boots (one labeled "Rheses Stunt, James") unseen in the film's final cut. The costume is accompanied by an additional pair of metal bracers (labeled "Moses 2") from a different scene. They feature blue leather panels and ornate scarab detailing. The costume exhibits intentional distressing to appear battle worn and minor marks on some components.

**Estimate: \$8,000 - 16,000**



**130**  
**Barney Ross' (Sylvester Stallone) Watch**  
**The Expendables 2 (2012)**

Barney Ross' (Sylvester Stallone) watch from Simon West's action sequel The Expendables 2. Ross wore his watch throughout the film as he and the Expendables avenged their fallen comrade.

Designed to resemble a Panerai Luminor watch, this watch features a gold-color stainless steel face inset with green luminous hour markers and affixed with white-stitched brown leather straps. It is applied with "Panerai" logos and etchings on the back and straps. The watch exhibits loose screws on the straps from production wear, and its current functionality is unknown.

Contains mechanical components; see notice in the Buyer's Guide.

**Estimate: \$5,000 - 10,000**



**131**  
**Barney Ross' (Sylvester Stallone)**  
**Costume, Knife, and Jump Pack**  
**The Expendables 3 (2014)**

Barney Ross' (Sylvester Stallone) costume, knife, and jump pack from Patrick Hughes' action sequel The Expendables 3. Ross wore his costume when he captured Conrad Stonebanks (Mel Gibson).

This lot consists of a black wool beanie reading "9 Signal Co.," a black cotton American Apparel long-sleeve shirt (L) marked "SCY"; matching black pants marked "HGRO [sic]"; a padded black tactical vest with an attached communications unit; a knife charm engraved "VIRTUS" on a metal chain necklace; a black leather thumb wrap with metal skull icons; a black suede and nylon fingerless glove; a black leather belt with holsters and a plated metal skull buckle; black lace-up boots; a urethane knife with a leather-wrapped wooden sheath marked "Elite Set 5 of 15 Gil Hibben"; a static padded black nylon jump pack; and a production tag. The belt and boots are replicas added to complete the costume. Also included is a fiberglass mannequin for display. The costume is intentionally distressed by production to appear well-worn with frayed fabric on the cap, pants, and vest.

**Estimate: \$10,000 - 20,000**





**132**  
 Barney Ross' (Sylvester Stallone) Stunt Noveske 16 Colt Hybrid Rifle  
**The Expendables 3 (2014)**

Barney Ross' (Sylvester Stallone) stunt Noveske 16 Colt hybrid rifle from Patrick Hughes' action-thriller film The Expendables 3. Ross wielded his hybrid rifle throughout the film as he fought against Stonebanks (Mel Gibson) and his men.

This rifle consists of black-painted rubber with a black-painted metal and fiberglass barrel and black nylon buckle strap zip-tied to the backing. This rifle is marked as a Noveske Rifleworks LLC rifle model N4 with a 5.56 mm gauge. This lot exhibits minor rubber tears and a loose barrel. Dimensions: 38" x 3" x 11" (96.75 cm x 7.75 cm x 28 cm)

Ownership may be restricted in some countries; see replica firearm notice in Buyer's Guide.

**Estimate: \$3,000 - 6,000**



**133**  
 Mr. Boggis' Model Miniature Farm Set  
**Fantastic Mr. Fox (2009)**

Mr. Boggis' model miniature farm set from Wes Anderson's animated comedy Fantastic Mr. Fox. Mr. Fox (George Clooney) and Kylie (Wallace Wolodarsky) stole chickens from Walt Boggis' (Robin Hurlstone) farm.

This lot consists of a wood and metal model miniature front half house featuring taped plastic windows and cotton fabric curtains; six painted "BOGGIS" letters; and two painted plaster coops marked "15" and "34" on wooden bases. This lot exhibits extreme fragility and damage and has undergone sympathetic repairs. Dimensions: 65" x 45" x 84" (165.25 cm x 114.25 cm x 213.5 cm)

Special shipping required; see notice in the Buyer's Guide.

Contains electronics; see electronics notice in the Buyer's Guide.

**Estimate: \$6,000 - 12,000**



5.4' (1.65m)



**134**  
 Morris Frye's Ferrari License Plate  
**Ferris Bueller's Day Off (1986)**

Morris Frye's Ferrari license plate from John Hughes' classic comedy Ferris Bueller's Day Off. Ferris Bueller (Matthew Broderick) convinced his best friend, Cameron Frye (Alan Ruck), to "borrow" his dad's prized Ferrari for a joyride around Chicago.

Four custom plates were made by production for the 1961 Ferrari 250 GT California (a modified MG sports vehicle), with this metal plate created for the climactic sequence where the car crashes through Mr. Frye's window. Following production, it entered the private collection of one of the property masters.

Designed to resemble an actual legal state plate, this plate is painted white with "Illinois" and "Land of Lincoln" decals applied on front, Dec. 1986 registration tags applied to both corners, and "NRVOUS" printed in raised blue lettering at center. It comes screwed into a steel frame from production. The plate exhibits rusting on the reverse, tearing to the decals, and scratched paint from being applied to and removed from the vehicle. Dimensions: 12" x 6.25" x 0.5" (30.5 cm x 16 cm x 1.5 cm)

**Estimate: \$40,000 - 80,000**



Photo 12 / Alamy Stock Photo



**135**  
 Kevin Costner-Autographed Screen-Matched Ray  
 Kinsella Baseball Glove and Related Materials  
**Field Of Dreams (1989)**

Ray Kinsella's (Kevin Costner) screen-matched baseball glove and related materials from Phil Alden Robinson's sports drama *Field of Dreams* autographed by Costner. This glove screen-matches to the film's finale, when Kinsella (Costner) played catch with his father John Kinsella (Dwier Brown) in the baseball field he built at his farm with the iconic line "Hey dad, you wanna have a catch?"

The subject of widespread critical acclaim upon its release, *Field of Dreams* was nominated for three Academy Awards®, including Best Picture. Often ranked among the most influential sports films of all time, it was inducted into the US National Film Registry by the Library of Congress in 2017 for its impact on American culture. An upgraded version of the original *Field of Dreams* baseball diamond Universal Studios constructed in Dyersville, Iowa for the film remains in use as a Major League Baseball ballpark today, including for a 2021 White Sox vs. Yankees game which Costner introduced.

This brown leather Wilson A2000 baseball glove was the high school glove of prop master Douglas Fox, who equipped Costner with it after the actor refused to use fresher equipment provided to the production for promotional consideration. Costner later signed it in silver-color ink when he and Fox again worked together on Niki Caro's *McFarland, USA*.

This glove features matching brown leather laces, a black and yellow sewn-in Wilson "W" logo, and a second Wilson logo near the wrist. Also included are a Letter of Authenticity from Fox, six continuity photos of Costner from production, a Wilson baseball bag, and two production-made paper Terrence Mann (James Earl Jones) graphics. The glove is distressed from personal use, and exhibits wrinkling and discoloration to the leather from age.

**Estimate: \$70,000 - 140,000**



AJ Pica / Alamy Stock Photo

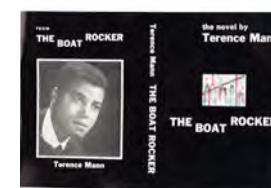



**136**  
**The Narrator's (Edward Norton)**  
**Rubber Smith & Wesson 4506**  
**Fight Club (1999)**

The Narrator's (Edward Norton) rubber Smith & Wesson 4506 from David Fincher's comedic thriller Fight Club. Tyler Durden (Brad Pitt) put the pistol The Narrator (Edward Norton) stole from a corrupt police officer into The Narrator's mouth.

This rubber gun is cast from a Smith & Wesson 4506 with serial number "T805398" and grooves on the top of the slide to match the hero guns created for the opening sequence by weapons specialist Mike Sudrow. The barrel is finished in silver-color paint to resemble stainless steel and the textured grip is painted black. This pistol exhibits brown staining and cracking paint throughout from production use. Dimensions: 8.5" x 6" x 1" (21.75 cm x 15.25 cm x 2.5 cm)

Ownership may be restricted in some countries; see replica firearm notice in Buyer's Guide.

**Estimate: \$4,000 - 8,000**

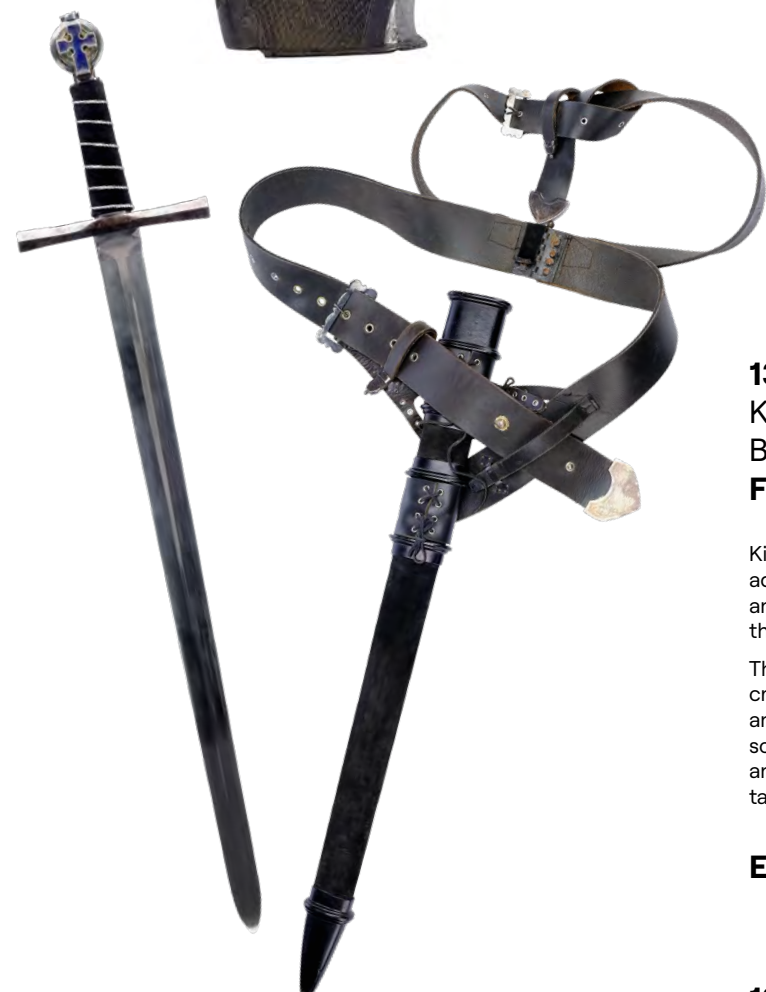

**137**  
**King Arthur's (Sean Connery) Sword, Scabbard, and**  
**Belt**  
**First Knight (1995)**

King Arthur's (Sean Connery) sword, scabbard, and belt from Jerry Zucker's adventure-drama film First Knight. King Arthur carried his sword in its scabbard and wore it on his belt when he and Lady Guinevere (Julia Ormond) presented themselves to Camelot.

This lot consists of a metal sword with a rounded pommel featuring a blue enamel cross and metal crown, a black leather handle with silver-color nylon thread and a flat metal hand guard; a black-painted leather and suede coated wooden scabbard with metal embellishments; and a black leather belt with a metal buckle and embellishments. This lot exhibits bent material on the pommel's crown and tarnishing. Dimensions: 44" x 8" x 5" (112 cm x 20.5 cm x 12.75 cm)

**Estimate: \$6,000 - 12,000**



**138**  
**Robin Williams, Cast, and Crew-Autographed "A"**  
**Camera Clapperboard**  
**Flubber (1997)**

An "A" camera clapperboard autographed by Robin Williams and other cast and crew members of Les Mayfield's sci-fi comedy Flubber. This white acrylic clapperboard with a striped black-and-white plastic slate was originally gifted by a crew member to a colleague.

It is engraved with the title, director "Les Mayfield," and cameraperson "Dean Cundey" in red text and signed in black marker by Williams, Mayfield, Cundey, Marcia Gay Harden, Raymond J. Barry, Christopher McDonald, Clancy Brown, and Wil Wheaton, who also drew a peace sign. The slate is dented and exhibits minor staining. Dimensions: 11" x 9.5" x 1" (28 cm x 24.25 cm x 2.5 cm)

**Estimate: \$5,000 - 10,000**

**MARIO KIRNER**  
**COLLECTION**

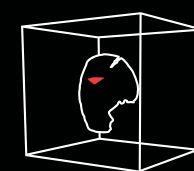

Friday the 13th  
 props museum

The following 11 lots come from the Friday the 13th Props Museum collection of Mario Kirner. The Museum was created as a private collection that showcased not only Jason's iconic hockey mask, but also a number of other movie props, costumes and additional materials that were used during the production of the Friday the 13th movies.

An avid contributor in the screen-used prop and costume collecting field for more than 20 years, Mario Kirner has been a dedicated in his work and efforts to help to transform what was once a niche hobby into an popular culture phenomenon. Mario is not just a collector, but a true historian and curator of all things Jason Voorhees and Friday the 13th, also publishing a book dedicated to showcasing the museum's content and their stories. Additional lots from the Mario Kirner collection can be found on Auction Day 2, see page 485.



**139**  
**Mario Kirner Collection: Jason**  
**Voorhees' (C.J. Graham) SFX**  
**Hockey Mask**  
**Friday The 13th Part VI: Jason Lives**  
**(1986)**

Jason Voorhees' (C.J. Graham) SFX hockey mask from Tom McLoughlin's horror sequel Friday the 13th Part VI: Jason Lives. This lot comes from the personal collection of Friday the 13th collector and historian Mario Kirner.

Jason wore his mask throughout the film as he terrorized teenagers and the police at Camp Forest Green. As the budget for the film was larger than previous entries, a total of 12 masks were made (11 for the initial filming and one for the post-production intro shot of Jason) and this is a vacuum-formed plastic mask made for the scene where Sheriff Garris (David Kagen) shot Jason in the head. The mask is accompanied by a letter of authenticity from special effects "powder man" Ken Sher, which details how the mask was originally fitted with a small detonation device and a blood bag but the shot was ultimately unused in the film. There is a hole in the forehead from the detonation and a noticeable area inside where the device was fitted. The mask exhibits stage blood residue and "6" is handwritten faintly inside. A notable crack runs across the forehead. Dimensions: 10" x 8.75" x 4.5" (25.5 cm x 22 cm x 11.5 cm)

**Estimate: \$15,000 - 30,000**



**140**  
**Mario Kirner Collection: Jason Voorhees' (Kane Hodder) Screen-Matched Hockey Mask**  
**Friday The 13th Part VII: The New Blood (1988)**

Jason Voorhees' (Kane Hodder) screen-matched hockey mask from John Carl Buechler's slasher sequel Friday the 13th Part VII: The New Blood. This lot comes from the personal collection of Friday the 13th collector and historian Mario Kirner. Jason wore his trademark hockey mask throughout the film after being inadvertently released from his tomb at the bottom of Camp Crystal Lake by telekinetic teenager Tina Shephard (Lar Park Lincoln). Markings and paintwork on the mask screen-match to several scenes.

Buechler created a dirtied white version of the mask which resembled a human skull. He cut down the overall shape, allowing more of the facial makeup appliances to be seen around the edges. Only two masks were created for this installment, unlike previous films, which saw several masks created. This was the primary mask used for filming, making it the most shown hockey mask in the film series. It comes from the collection of Friday the 13th collector and historian Mario Kirner.

The second mask was an SFX version created for the sequence where the mask split in half.

This primary mask became damaged and scratched during several scenes. Hodder received a severe hit to the face from the falling ceiling lamp before he fell through the stairs and stated that the mask was scratched around the mouth and nose when the roof fell on him. As scenes were not filmed chronologically, the difference in specific damage and distressing on the mask between sequences is noticeable throughout the film.

The mask is made of vacuum-formed plastic spray-painted off-white with shades of brown applied. A decorative red triangle emblem is painted on the forehead, and three brown leather straps are adhered to the mask with brass split pins. Black nylon mesh is glued within one eyehole, added to cover Hodder's left eye and to enhance the skull-like design. The mask is heavily distressed to appear aged, including a damaged section on the left side. Buechler purposefully included this damaged section to tie in with the ending of Friday the 13th Part VI: Jason Lives when a propeller hits the mask. There is visible glue residue around the mesh on the interior, and the fragile mask exhibits scratches and paint wear from production use. Dimensions: 9.5" x 8.25" x 7.5" (24 cm x 21 cm x 19 cm)

**Estimate: \$60,000 - 120,000**



141

Mario Kirner Collection: Jason Voorhees'  
(Kane Hodder) Screen-Matched Costume  
**Friday The 13th Part VII: The New Blood (1988)**

Jason Voorhees' (Kane Hodder) screen-matched costume from John Carl Buechler's slasher sequel Friday the 13th Part VII: The New Blood. This lot comes from the personal collection of Friday the 13th collector and historian Mario Kirner. Jason wore his highly distressed costume throughout the film after being inadvertently released from his tomb at the bottom of Camp Crystal Lake by telekinetic teenager Tina Shephard (Lar Park Lincoln). Tears on the bottom of each trouser leg screen match to the moment Jason pulls the machete out from a tree after killing Dan (Michael Schroeder). The placement of rips and marks on the shirt's left shoulder screenmatch to just before Jason is electrocuted in a puddle.

The costume in this installment was the most torn-up to feature in the film series, and this example is believed to be one of four complete costumes worn on screen. The green workwear set consists of a shirt and trousers (size 34) that are highly distressed with various rips and staining. Hodder wore an undersuit covered in skin appliances designed to emulate rotting bones and flesh beneath these garments. "A" is handwritten inside the trouser waistband, indicating that this version was the main hero version. Effects coordinator Lou Carlucci also altered this attire for the electrocution scene. The lot exhibits pyrotechnic squibs and burn spots on the shirt and trousers. Foam and glue remnants from the undersuit exhibit inside both garments, and the costume retains a musty odor.

**Estimate: \$20,000 - 40,000**



142

Jason Voorhees' (Kane Hodder) Production-Made Hockey Mask  
**Friday The 13th Part VIII: Jason Takes Manhattan (1989)**

Jason Voorhees' (Kane Hodder) hockey mask from Rob Hedden's slasher sequel Friday the 13th Part VIII: Jason Takes Manhattan. Throughout the film, Jason wore his infamous hockey mask as he stalked and terrorized a class of high-school graduates on a cruise ship en route to New York after being accidentally resurrected from the bottom of Crystal Lake.

Gifted to the senior SFX coordinator Tony Lazarowich at the end of filming, this cast acrylic hockey mask was made for production by Lazarowich as a stand-by for the "Hero" masks, but was ultimately unused. It is painted yellow with three red triangular emblems on the forehead and cheeks. The eye holes are covered by a black mesh fabric glued in place. It features three leather straps held together by a three-sided halter square brass buckle. Production intentionally distressed this mask, including the ax crack in the forehead from Friday the 13th Part III. This lot features notable adhesive marks, a tear in the black mesh, notable denting, and notable paint marks on the front.

**Estimate: \$15,000 - 30,000**

**143**  
 Mario Kirner Collection: Jason Voorhees' (Kane Hodder) Stunt Undersuit  
**Friday The 13th Part VII: The New Blood (1988)**

Jason Voorhees' (Kane Hodder) stunt undersuit from John Carl Buechler's slasher sequel Friday the 13th Part VII: The New Blood. This lot comes from the personal collection of Friday the 13th collector and historian Mario Kirner. This suit was used for the stunt where Jason was set on fire in the cabin basement by telekinetic teenager Tina Shephard (Lar Park Lincoln), as well as the electrocution scene.

At the time, Hodder set a new record for the longest on-camera controlled burn and was on fire for forty seconds.

Hodder wore this suit and a pair of fire-resistant underwear as protection underneath his costume. The undersuit consists of brown mechanic coveralls (size Large) with adhered silicone ribcage and rotten skin appliances. Director Buechler chose silicone as the material for the appliances so they would last longer under heat. Strips of hook-and-loop fasteners are attached down the front. The lot exhibits significant wear and damage caused by the fire.

**Estimate: \$5,000 - 10,000**



**144**  
 Mario Kirner Collection: FX Head  
**Jason Goes To Hell: The Final Friday (1993)**

An FX head from Adam Marcus' slasher sequel Jason Goes to Hell: The Final Friday. This lot comes from the personal collection of Friday the 13th collector and historian Mario Kirner. After Jessica (Kari Keegan) drove her knife into Jason's (Kane Hodder) heart, an orange ball of energy shot into the sky and demonic hands broke through the ground dragging Jason down to hell. This foam-filled latex FX head, sculpted by Wayne Toth and cast by special effects artist Brian Rae, features thin strands of real hair glued across the top. It has been airbrushed in blues and purples to encapsulate his rotting flesh and enhance the shadows and bulbous structure during the brightly lit scene. The head has been affixed to a metal stand and exhibits wear from production use and age, including splits and torn foam sections, including a large disintegrated section of the left neck. Dimensions: 11.8" x 13.4" x 11.8" (30 cm x 34 cm x 30 cm)

**Estimate: \$3,000 - 6,000**

**145**  
 Mario Kirner Collection: Jason Voorhees' (Kane Hodder) Screen-Matched Bullet-Hit Shirt, Trousers and Undersuit  
**Jason X (2001)**

Jason's (Kane Hodder) screen-matched bullet-hit shirt, trousers and undersuit from Jim Isaac's horror sequel Jason X. This lot comes from the personal collection of Friday the 13th collector and historian Mario Kirner.

Jason wore his increasingly distressed costume for much of the film as he terrorized teenagers in the future, and the shirt screen-matches the one he wore as he slowly approached Professor Lowe (Jonathan Potts) and retrieved his machete, through the faux blood staining and holes.

The costume consists of a grey shirt (labeled "2" in the collar), grey trousers (labeled "128"), and a padded undersuit. The undersuit has a padded chest, a wound prosthetic, tape across the chest, and has been autographed in black ink by Hodder. The shirt and trousers exhibit heavy distressing with bullet holes and faux blood, with several of the holes featuring prosthetic wounds. The shirt exhibits a huge hole in the gut where Jason was impaled on a spike.

**Estimate: \$8,000 - 16,000**

**146**  
 Mario Kirner Collection: Jason Voorhees' (Kane Hodder) Screen-Matched Bullet-Hit Shirt and Trousers  
**Jason X (2001)**

Jason Voorhees' (Kane Hodder) screen-matched bullet-hit shirt and trousers from Jim Isaac's horror sequel Jason X. Jason wore his increasingly distressed costume for much of the film as he terrorized teenagers in the future, and the shirt screen-matches the one he wore as he followed Rowan (Lexa Doig) into the cryo-chamber through the stage blood stains and the patterns on the buttons. This lot comes from the personal collection of Friday the 13th collector and historian Mario Kirner.

The costume consists of a gray shirt and trousers, both exhibiting intentional distressing with bullet holes, stage blood, and staining. The trousers have "1" handwritten inside the waistband.

**Estimate: \$5,000 - 10,000**



Maximum Film / Alamy Stock Photo

**147**  
**Robert Englund-Autographed Freddy Krueger Fedora**  
**Freddy Vs. Jason (2003)**

A Robert Englund-autographed Freddy Krueger fedora from Ronny Yu's horror crossover Freddy vs. Jason. The dream-stalking Freddy wore his signature fedora throughout the film, while battling infamous serial killer Jason Voorhees (Ken Kirzinger).

This lot consists of one brown felt hat with a 22" (56 cm) band size. The hat features an intentionally darkened ring around the crown in place of a hatband or trim. The sweatband features two Edie's Hats of Vancouver logos and an interior size tag. This hat also features Robert Englund's autograph on the leather sweatband with a number "1" next to his name in silver-color permanent marker. This hat exhibits intentional distressing by production, including a number of small nicks and cuts to the crown and brim, to appear damaged and well worn. This lot exhibits minor fading and stiffen, dry leather.

**Estimate: \$20,000 - 40,000**



**148**  
**Mario Kirner Collection:**  
**Autographed Stunt Jason**  
**(Ken Kirzinger) Machete**  
**Freddy Vs. Jason (2003)**

An autographed stunt Jason (Ken Kirzinger) machete from Ronny Yu's horror crossover Freddy vs. Jason. This lot comes from the personal collection of Friday the 13th collector and historian Mario Kirner. Jason used his machete throughout the film, while cutting down teenagers and fighting against Freddy Krueger (Robert Englund). At one point, he even had it turned against him by Freddy. Production designer John Willett designed the film's machetes, and many were made for a variety of different uses and "gags."

This machete is a rubber stunt version with a metal armature. It is painted to look like metal and has tape wrapped around the handle. The blade has been autographed and inscribed "Used by myself in 'Freddy Vs. Jason' by Kirzinger. The blade exhibits some paint wear from use, and the metal armature is protruding from the end of the blade. Dimensions: 30" x 1" x 4.25" (76 cm x 2.5 cm x 11 cm)

**Estimate: \$4,000 - 8,000**



**149**  
**Jason Voorhees' (Ken Kirzinger) 3/4 Scaled Machete**  
**Freddy Vs. Jason (2003)**

Jason Voorhees' (Ken Kirzinger) 3/4 scaled machete from Ronny Yu's horror mash-up Freddy Vs. Jason. Jason wielded his machete throughout the film as he attacked the teens and fought Freddy Krueger (Robert Englund).

Designed by production designer John Willett, this lot consists of one machete made for specialized shots to make Jason appear larger. It features a solid aluminum blade with cross guard, and a tape-wrapped wooden handle. This machete was intentionally distressed by production. This lot exhibits mild discoloration and knicks in the metal blade. Dimensions: 24" x 2.75" x 1" (61 cm x 6.75 cm x 2 cm)

Blade was dulled by production.

**Estimate: \$4,000 - 8,000**





**150**  
 Mario Kirner Collection: Costume, Prosthetic Head & Torso,  
 Bear Trap & Chain  
**Friday The 13th (2009)**

A costume, prosthetic head, body under-suit, bear trap, and chain from Marcus Nispel's horror reboot Friday the 13th. This lot comes from the personal collection of Friday the 13th collector and historian Mario Kirner. Jason Voorhees (Derek Mears) wore his costume throughout the film.

It features a white T-shirt, dark green trousers, and a green and blue quilted coat comprising the lower half of a parka and the upper half of a hunter jacket. The holes and stains on the T-shirt and coat screen-match them to scenes where Jason impaled Chewie (Aaron Yoo). The prosthetic torso is made of flesh-color foam-latex. Featuring a rear zipper, it depicts a sinewy, bloodstained abdomen. The separate prosthetic foam-latex head depicts Jason's large, deformed cranium, stout neck, broad shoulders, and hand-stitched hair. The prosthetic does not extend to the face, as the piece was used for scenes where Jason wore a hockey mask. Both prosthetics are presented on a white plastic mannequin display. Clay (Jared Padalecki) used a bear trap to stab and bind Jason in the climactic fight. Made of metal with metal screws and rubber teeth, the trap features dual-spring levers, a circular plate and a stock bar, attached to which is a long resin chain. The lot is accompanied by a studio letter of authenticity for the costume. All costume elements exhibit perforations, staining, and heavy distressing. The prosthetics exhibit stiffening from age, becoming brittle near the edges, and some holes are present. The trap exhibits production-added, rust-colored paint to create an aged effect. Some chain links are severed at their mid-point. As this lot ships from Propstore's London Office, shipping must be arranged with Propstore prior to bidding. Dimensions: (bear trap and chain) 60" x 16" x 6" (151 cm x 41 cm x 14 cm); (head and torso) 33 1/2" x 23" x 11" (85 cm x 58 cm x 28 cm)

**Estimate: \$30,000 - 60,000**



**151**  
**Mario Kirner Collection: Jason Voorhees' (Derek Mears) Hero Machete Friday The 13th (2009)**

Jason Voorhees' (Derek Mears) hero machete from Marcus Nispel's horror reboot Friday the 13th. This lot comes from the personal collection of Friday the 13th collector and historian Mario Kirner. Jason carried his machete throughout the film and used it to kill his victims, including to stab Trent (Travis Van Winkle) and, in the climactic fight, by Whitney Miller (Amanda Righetti) to stab Jason.

This aluminum machete has been coated with a black finish and rust to show wear. The wooden handle features dual metal screws and is wrapped in leather and burlap straps. The machete is one of 17 made for the production, of which eight survive, with prop master Koen Wooten confirming it was the main machete used on the camp location. The lot exhibits signs of wear commensurate with its age and production use, including staining.

Dimensions: 36" x 3" x 1.25" (91 cm x 8 cm x 3 cm)

**Estimate: \$7,000 - 14,000**



**152**  
**Don "Wardaddy" Collier's (Brad Pitt) Bloodied SFX Jacket Fury (2014)**

Don "Wardaddy" Collier's (Brad Pitt) bloodied SFX jacket from David Ayer's war-drama film Fury. Wardaddy wore his tanker jacket while he and the Fury crew held off a battalion of SS troopers during an explosive standoff on the road.

This lot consists of Wardaddy's cotton and wool lined brown bloodied SFX jacket featuring stage blood staining, numerous bullet holes strewn across the torso and unit and rank patches, and a white bloodied medical gauze wrap around the left arm. Pieces of the lining have been removed where squibs were likely located around the bullet holes. This lot exhibits wear and production distressing.

**Estimate: \$2,500 - 5,000**



**153**  
**Don "Wardaddy" Collier's (Brad Pitt) M1 Helmet Fury (2014)**

Don "Wardaddy" Collier's (Brad Pitt) M1 helmet from David Ayer's war-drama film Fury. Wardaddy wore his helmet during a platoon rescue mission.

This lot consists of a black and green color metal M1 helmet with a brown plastic insert featuring nylon, elastic, and leather straps, and a pair of metal frame goggles with clear acrylic lens, a suede and brown leather trim, and a brown elastic strap. This lot exhibits intentional distressing from production, and scuffs and worn elastic on the goggles and helmet.

**Estimate: \$3,000 - 6,000**

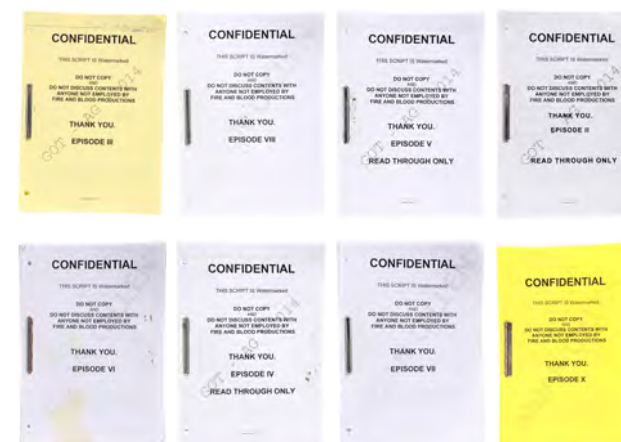

**155**  
**Set of Aidan Gillen's Eight Personal Season 1 Scripts Game Of Thrones (2011-2019)**

Aidan Gillen's eight personal Season 1 scripts from the production of the fantasy drama series Game of Thrones. Gillen portrayed Petyr "Littlefinger" Baelish throughout the season.

This set consists of a 40-page "Episode II" script; a 50-page "Episode III" yellow draft script dated July 16, 2012 with handwritten annotations regarding scene notes and dialogue; a 38-page "Episode IV" script; a 37-page "Episode V" script; a 44-page "Episode VI" script; a 38-page "Episode VII" script; a 52-page "Episode VIII" script; and a 59-page "Episode X" yellow draft script dated October 24, 2010. Each comes watermarked "GOT-AG-014" and "AIDAN GILLEN" inside a clear plastic zip-up sleeve. The set exhibits stains and wrinkling throughout from use. Dimensions: (each) 9.5" x 12.5" x 0.25" (24.25 cm x 31.75 cm x 0.75 cm)

**Estimate: \$5,000 - 10,000**



**154**  
**Don "Wardaddy" Collier's (Brad Pitt) Tank Helmet with Goggles Fury (2014)**

Don "Wardaddy" Collier's (Brad Pitt) tank helmet with goggles from David Ayer's war-drama film Fury. Wardaddy wore his helmet in the Fury tank with his unit throughout the film.

This lot consists of a green color metal fiberglass helmet with a brown leather insert featuring an elastic strap and a pair of metal frame goggles with clear acrylic lens, a suede and brown leather trim, and a brown elastic strap. It features an AUX cable that allowed Wardaddy to communicate with his unit and is marked "BRAD 22 1/12" in blue ink on tape in the interior. This lot exhibits intentional distressing from production and scuffs and worn elastic on the goggles and helmet.

Contains mechanical components; see notice in the Buyer's Guide.

**Estimate: \$3,000 - 6,000**



**156**  
**Set of Aidan Gillen's Seven Personal Annotated Season 2 Scripts Game Of Thrones (2011-2019)**

Aidan Gillen's seven personal scripts from Season 2 of the fantasy drama series Game of Thrones. Gillen portrayed Petyr "Littlefinger" Baelish throughout the season.

This set consists of metal-bound scripts labeled for episodes "201," "202," "203," "204," "205," "206," and "210. Each comes watermarked "Aidan Gillen," and the scripts for "201" and "204" feature handwritten annotations in pen. The set comes housed in clear plastic resealable slider storage bags with colorful sliders. They exhibit creased corners, fold lines, and discoloration throughout from use. Dimensions: (each) 9.5" x 12.5" x 0.25" (24.25 cm x 31.75 cm x 0.75 cm)

**Estimate: \$4,000 - 8,000**



**157**  
Alexander Dane's (Alan Rickman) Dr. Lazarus Costume  
**Galaxy Quest (1999)**

Alexander Dane's (Alan Rickman) Dr. Lazarus costume from Dean Parisot's sci-fi comedy Galaxy Quest. After the Thermians transported Alexander and the other cast members aboard, Alexander donned his Galaxy Quest uniform the Thermians recreated.

This uniform consists of a gray and purple poly-blend knit jumpsuit. It features a white and blue embroidered Galaxy Quest emblem patch on the left side, three silver-color metal rectangular studs and a zip front with a decorative metal triangular slider. The inner seam of the jumpsuit features a Bill Hargate Costumes tag with a very faded hand-marked "Alan" beneath it. This costume exhibits discoloration and frayed applique edges.

**Estimate: \$4,000 - 8,000**



**158**  
Major's Bomber Jacket Costume  
**Ghost In The Shell (2017)**

Major's bomber jacket costume from Rupert Sanders' sci-fi action film Ghost in the Shell. Major (Scarlett Johansson) wore her bomber jacket throughout the film.

This lot consists of two synthetic wigs with one having a lace front; a gray polyester bomber-style jacket with brown cotton knit hems and a metal zipper; a gray ribbed cotton tank top; black cotton and Spandex trousers; and black pleather lace-up ankle boots. The tank features a hand-marked tag for "Major C 3, 8 30/30" and the trousers feature a hand-marked tag for "Major Dodgy Stunt C 3 6/7." This costume exhibits frayed edges and discoloration on the jacket.

**Estimate: \$6,000 - 12,000**

## STUART ZIFF COLLECTION

Upon moving to Edlund's Entertainment Effects Group (later renamed Boss Film Studios) in 1983, Ziff headed the 50-person "Ghost Shop" responsible for the groundbreaking demonic special effects in Ivan Reitman's comedy classic Ghostbusters. Numerous ghosts and spectral phenomena created for the picture, including the Stay-Puft Marshmallow Man's costume, immediately landed in the American pop culture lexicon, where they've remained for nearly four decades. Propstore is proud to offer never-before-seen production materials from Stuart Ziff's pioneering work on Ghostbusters, alongside other one-of-a-kind memorabilia from his 40-plus-year career as a Hollywood pioneer.

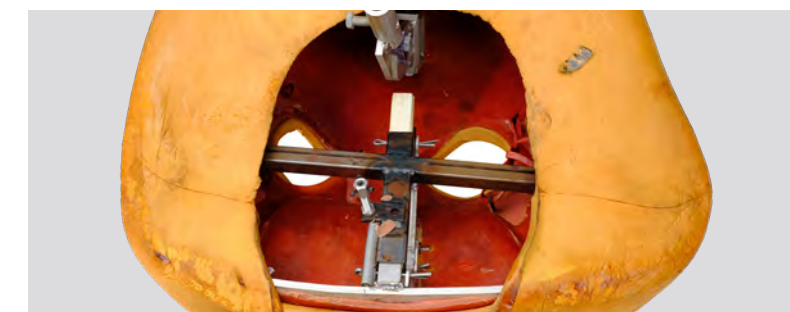

**159**  
Stuart Ziff Collection: Stay Puft Stretching  
Mechanical Head Prototype  
**Ghostbusters (1984)**

A Stay Puft Marshmallow Man stretching mechanical head prototype from Ivan Reitman's fantasy-comedy film Ghostbusters. The Stay Puft Marshmallow Man ghost attacked the Ghostbusters after a failed attempt to stop Gozer.

This lot comes from the collection of Ghost Shop creature effects supervisor Stuart Ziff. It consists of a foam head skin of the Stay Puft Marshmallow Man stretching over a fiberglass base. This unused piece was intended to show Stay Puft "melting" while being hit by charged particle beams from the Ghostbusters' neutrona wands, and includes a mechanism to stretch the mouth. This prototype also features a welded metal frame that allowed the head to stay in place when mounted. This lot exhibits discoloration from age. Dimensions: 18" x 12" x 12" (45.75 cm x 30.5 cm x 30.5 cm)

Contains mechanical components; see notice in the Buyer's Guide.

**Estimate: \$4,000 - 8,000**



**160**  
Stuart Ziff Collection: Stay Puft  
Marshmallow Man's (Bill Bryan) Red Tie  
**Ghostbusters (1984)**

The Stay Puft Marshmallow Man's (Bill Bryan) red tie from Ivan Reitman's supernatural comedy Ghostbusters. After the Ghostbusters were told to choose the form of the destructor, Ray Stantz (Dan Aykroyd) unintentionally thought of the Stay Puft Marshmallow Man mascot, and unleashed a giant version of it onto New York City.

This foam tie comes from the collection of Ghost Shop creature effects supervisor Stuart Ziff. It is painted red and shaped to look like a sailor's necktie. It exhibits cracking, some discoloration, and rough ends where it would have connected to the underside of the collar.

**Estimate: \$8,000 - 16,000**



24" (61 cm)



**161**  
 Stuart Ziff Collection: Terror Dog Head Set with Insert Shot Eye  
**Ghostbusters (1984)**

Terror Dog head set with insert shot eye from Ivan Reitman's supernatural comedy Ghostbusters. A terror dog kidnapped Dana Barrett (Sigourney Weaver) to take her to become a servant of Gozer.

This set comes from the collection of Ghost Shop creature effects supervisor Stuart Ziff. It consists of a latex foam head and neck with an empty eye socket and half the face removed; half of a latex foam terror dog face featuring a red acrylic eye mounted to a wooden base with metal brackets and loose cables; a red acrylic bulb; and two brown painted textured, carved resin horns. The mounted half face was used when the terror dogs emerged from the stone using air compression, the remaining head was ultimately not seen in the film. This lot exhibits grime and minor deterioration from age. Dimensions: (largest) 24" x 12" x 24" (61 cm x 30.5 cm x 61 cm)

Contains electronics; see electronics notice in the Buyer's Guide.

**Estimate: \$15,000 - 30,000**

**162**  
 Stuart Ziff Collection:  
 Terror Dog Foot with Claw Set  
**Ghostbusters (1984)**

A terror dog foot with a claw set from Ivan Reitman's supernatural comedy Ghostbusters. A terror dog emerged from stone before it kidnapped Dana Barrett (Sigourney Weaver) to take her to become a servant of Gozer.

This lot comes from the collection of Ghost Shop creature effects supervisor Stuart Ziff. It consists of a brown latex foam terror dog foot; three brown painted textured and carved resin claws; and one unpainted resin claw. The claws were used during the emerging scene. The foot exhibits extremely brittle material on the toes and the claws exhibit rough edges. Dimensions: 14" x 9" x 7" (35.75 cm x 23 cm x 18 cm)

**Estimate: \$4,000 - 8,000**



**163**  
 Stuart Ziff Collection: Clawed Demon Creature Glove  
**Ghostbusters (1984)**

A clawed demon creature glove from Ivan Reitman's fantasy-comedy film Ghostbusters. Demonic arms burst through a chair and grabbed Dana Barrett (Sigourney Weaver) while she was sitting in her apartment.

This brown latex demon claw glove features synthetic hair throughout and three foam claws. The glove was worn by puppeteers when Weaver was grabbed by the demon arms while in the chair. This glove exhibits fragile material with deterioration and cracking from age. Dimensions: 26" x 6" x 0.5" (66 cm x 15.25 cm x 1.5 cm)

**Estimate: \$3,000 - 6,000**



**164**  
 Stuart Ziff Collection:  
 Screen-Matched Posable Demon  
 Puppet Arm with Original Crate  
**Ghostbusters (1984)**

A screen-matched posable demon puppet arm with its original crate from Ivan Reitman's supernatural comedy Ghostbusters. Demonic arms burst through a chair and grabbed Dana Barrett (Sigourney Weaver) while she was sitting in her apartment. This arm was created for, and screenmatches to, the shots in which Barrett's chair was dragged across the room, as the gloved puppeteers used in closeups could not move along with the chair.

This dark blue foam latex arm comes from the collection of Ghost Shop creature effects supervisor Stuart Ziff. It comes molded around a metal base secured with a white nylon elastic cable from the arm secured to the base. Also included is its original wooden production crate marked "Demonic Arms" with a metal puppeteering rod. The arm exhibits cracking and tearing ripping foam, and the wood exhibits splitting. Dimensions: (crated) 42" x 20" x 7" (106.75 cm x 51 cm x 18 cm)

Contains mechanical components; see notice in the Buyer's Guide.

**Estimate: \$4,000 - 8,000**



**166**  
 Stuart Ziff Collection:  
 Mechanical Demon Puppet Arm  
**Ghostbusters (1984)**

A mechanical demon puppet arm from Ivan Reitman's supernatural comedy Ghostbusters. Demonic arms burst through a chair and grabbed Dana Barrett (Sigourney Weaver) while she sat in her apartment. This arm was created for the shots in which Barrett's chair was dragged across the room, as the gloved puppeteers used in closeups could not move along with the chair.

This mechanical arm comes from the collection of Ghost Shop creature effects supervisor Stuart Ziff. It is made of dark blue latex foam with synthetic hair over a metal frame and base with a white nylon elastic cable extending from the arm and secured to the base. This arm exhibits discoloration, cracked latex, and smashed fingertips from storage. Dimensions: 28" x 9" x 4" (71.25 cm x 23 cm x 10.25 cm)

Contains mechanical components; see notice in the Buyer's Guide.

**Estimate: \$4,000 - 8,000**



**165**  
 Stuart Ziff Collection:  
 Demon Puppet Arm  
**Ghostbusters (1984)**

A demon puppet arm from Ivan Reitman's supernatural comedy Ghostbusters. Demonic arms burst through a chair and grabbed Dana Barrett (Sigourney Weaver) while she was sitting in her apartment. This arm was created for the shots in which Barrett's chair was dragged across the room, as the gloved puppeteers used in closeups could not move along with the chair.

This demon arm puppet comes from the collection of Ghost Shop creature effects supervisor Stuart Ziff. It's made of brown latex foam with synthetic hair and painted resin claws over a metal base with a white nylon elastic cable extending from the arm and secured to the base. This arm exhibits a crack in the frame, ripping latex foam, a missing claw exposing the foam, and wear to the cable. Dimensions: 24" x 4" x 4" (61 cm x 10.25 cm x 10.25 cm)

**Estimate: \$4,000 - 8,000**



**167**  
**Hand-Painted New York Building Matte Painting Ghostbusters (1984)**

A hand-painted Michelle Moen New York building matte painting from Ivan Reitman's sci-fi comedy Ghostbusters. Gozer (Slavitz Jovan) took the form of a gigantic Stay Puft Marshmallow Man and wreaked havoc on New York City before the Ghostbusters destroyed him.

Hand-painted by Moen, this matte painting was used as the background of the scene. It features a building's side and a portion of its roof on particle board. The top edge is lined in black tape. It exhibits some notable paint marks, some scuffing, chipped edges, and lifted adhesive. Dimensions: 52" x 38.5" (132 cm x 98 cm)

Sold without copyright; please see notice in the Buyer's Guide.

**Estimate: \$4,000 - 8,000**

**168**  
**Stuart Ziff Collection: Stay Puft Marshmallow Man Unfinished Head Skin Ghostbusters (1984)**

A Stay Puft Marshmallow Man unfinished head skin from Ivan Reitman's supernatural comedy Ghostbusters. The Stay Puft Marshmallow Man ghost attacked the Ghostbusters after a failed attempt to stop Gozer.

This lot comes from the collection of Ghost Shop creature effects supervisor Stuart Ziff. It consists of a rubber foam skin, originally intended for use on a mechanical costume head, over a sculpted foam Stay Puft Marshmallow Man head mounted to a wooden base. This head exhibits extensive cracks, flaking, and scuffs from the skin and grime to the foam. Dimensions: 16" x 14" x 17" (40.75 cm x 35.75 cm x 43.25 cm)

**Estimate: \$3,000 - 6,000**

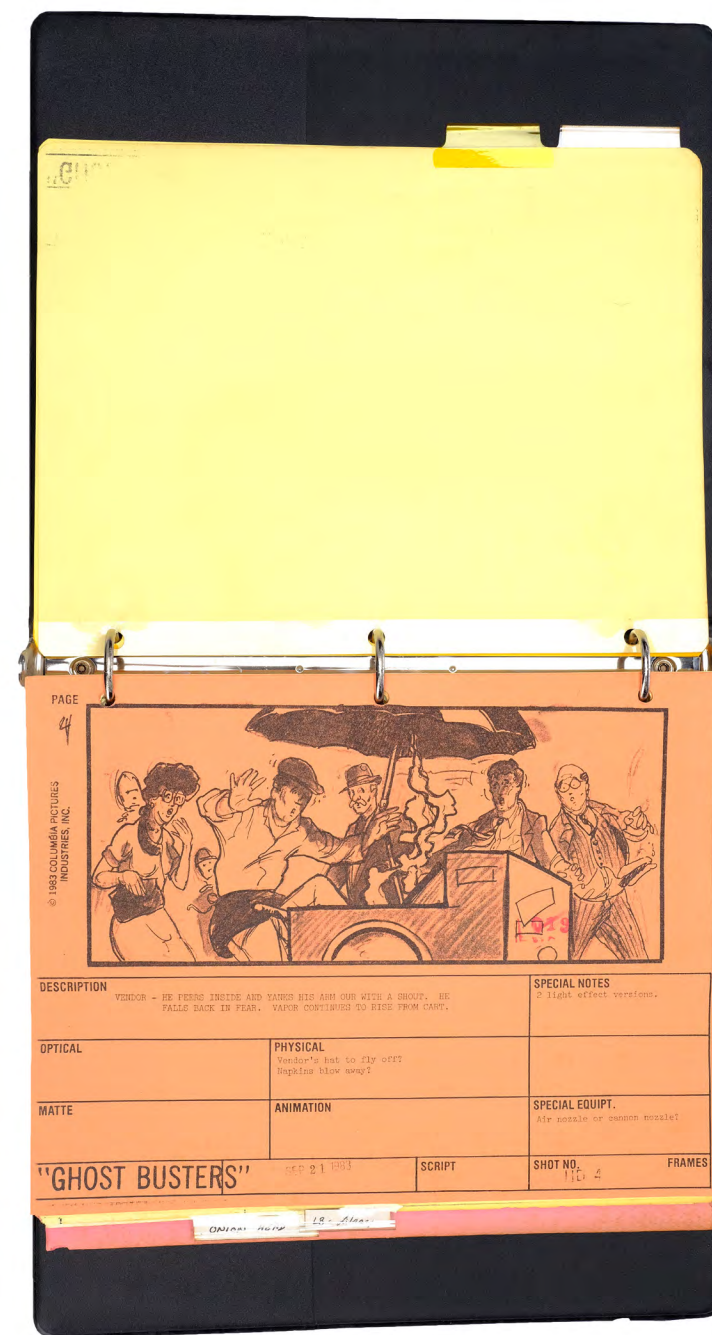

**169**  
**Stuart Ziff Collection: Production Binder of Printed Storyboard Copies Ghostbusters (1984)**

A production binder of printed storyboard copies from Ivan Reitman's supernatural comedy Ghostbusters. This lot comes from the collection of Ghost Shop creature effects supervisor Stuart Ziff. It consists of a production binder labeled "GHOSTBUSTER'S STORYBOARDS [sic]" containing 128 pages of storyboard printed on yellow and pink paper. The binder has five manila dividers labeled including "Ghost Jail," "LB - Library," and "Onion Head." Some of the pages exhibit creases and discoloration from age. Dimensions: 10.5" x 11.5" x 1.5" (26.75 cm x 29.25 cm x 4 cm)

**Estimate: \$2,000 - 4,000**



**170**  
**Stuart Ziff Collection: Storyboard and Concept Art Binder Ghostbusters (1984)**

Ghost Shop creature effects supervisor Stuart Ziff's personal storyboard and concept art binder from the production of Ivan Reitman's supernatural comedy Ghostbusters. This red plastic three-ring binder hand-marked "GHOSTBUSTERS STORYBOARDS" comes from Ziff's collection. It contains 293 three-hole punched storyboard copies, 32 three-hole punched art concept copies (e.g. Stay-Puft Marshmallow Man), with selective handwritten annotations, all organized and separated by tab dividers with hand-marked scene titles, e.g. "DANA CHAIR," "HOT DOG," "BJ FORT," et al. Loose-bound production memoranda include effects shot list and pre-production schedule. The paperwork exhibits edgewear and minor discolorations. Dimensions: 11" x 11.5" x 2.5" (28 cm x 29 cm x 6.25 cm)

Sold without copyright; see notice in the Buyer's Guide.

**Estimate: \$2,000 - 4,000**



**171**  
Dr. Erin Gilbert's Stunt Jumpsuit  
**Ghostbusters (2016)**

Dr. Erin Gilbert's stunt jumpsuit from Paul Feig's supernatural comedy Ghostbusters. Gilbert (as played by Kristen Wiig) wore her specially-made jumpsuit while she investigated a series of paranormal activities throughout New York City alongside her team of fellow Ghostbusters.

This beige zip-up jumpsuit features orange and gray striped reflective accents on the chest, back, arms, and ankles. The chest is affixed with a "GILBERT" patch while the right shoulder features a classic black, white, and red Ghostbusters patch. The jumpsuit exhibits signs of wear throughout from age and use.

**Estimate: \$2,500 - 5,000**



**172**  
Dr. Abby Yates' Jumpsuit  
**Ghostbusters (2016)**

Dr. Abby Yates' jumpsuit from Paul Feig's supernatural comedy Ghostbusters. Yates (as played by Melissa McCarthy) wore her specially-made jumpsuit while she investigated a series of paranormal activities throughout New York City alongside her team of fellow Ghostbusters.

This beige zip-up jumpsuit features orange and gray striped reflective accents on the chest, back, arms, and ankles. The chest is affixed with a "YATES" patch while the right shoulder features a classic black, white, and red Ghostbusters patch. The jumpsuit exhibits signs of wear throughout from age and use.

**Estimate: \$2,500 - 5,000**



**173**  
Dr. Jillian Holtzmann's Jumpsuit  
with Upper Arm Remote Trigger  
**Ghostbusters (2016)**

Dr. Jillian Holtzmann's jumpsuit with an upper arm remote trigger from Paul Feig's supernatural comedy Ghostbusters. Holtzmann (as played by Kate McKinnon) wore her specially-made jumpsuit and remote trigger while she investigated a series of paranormal activities throughout New York City alongside her team of fellow Ghostbusters.

This beige zip-up jumpsuit features orange and gray striped reflective accents on the chest, back, arms, and ankles. The chest is affixed with a "HOLTZMANN" patch while the right shoulder features a classic black, white, and red Ghostbusters patch. Also included is a black plastic and rubber remote trigger with a series of decorative wires and a black nylon fastening strip strap. The jumpsuit exhibits signs of wear throughout from age and use.

**Estimate: \$2,500 - 5,000**



**174**  
Patty Tolan's Jumpsuit  
**Ghostbusters (2016)**

Patty Tolan's jumpsuit from Paul Feig's supernatural comedy Ghostbusters. Tolan (as played by Leslie Jones) wore her specially-made jumpsuit while she investigated a series of paranormal activities throughout New York City alongside her team of fellow Ghostbusters.

This beige zip-up jumpsuit features orange and gray striped reflective accents on the chest, back, arms, and ankles. The chest is affixed with a "TOLAN" patch while the right shoulder features a classic black, white, and red Ghostbusters patch. The jumpsuit exhibits signs of wear throughout from age and use.

**Estimate: \$2,500 - 5,000**



**175**  
**Light-Up V-3 Style Proton Pack**  
**Ghostbusters (2016)**

A light-up V-3 style proton pack from Paul Feig's supernatural comedy Ghostbusters. A new team of paranormal investigators (as played by Kristen Wiig, Melissa McCarthy, Leslie Jones, and Kate McKinnon) wore the final iteration of their specially-created backpacks, which gave them the ability to contain and catch ghosts. 'V-3' was the production name for this model of pack, with the 'V-2' being the earlier backpack-style and the 'V-1' presumably the non-backpack 'proton box' first built by the Ghostbusters in the film.

This proton pack consists of a metal backing frame affixed with adjustable gray and orange nylon straps and a series of decorative details. These details include a metal-mesh dome-like feature over a series of coils; metal and nylon cables and wiring; several metal circuitry plates; a pressure gauge; several control boxes featuring levers and knobs; and a black plastic box with decorative studs. Attached to the pack via a series of cables is the pack's plastic and rubber "wand", which affixes to the pack via magnets.

Activating a pair of battery-operated switches on the pack will cause the coiled cables, as well as several of the control boxes, to illuminate. The battery-operated wand also features several lights and an illuminating barrel which can be activated via a switch and trigger on its body and grip. Also included in the lot are two sizes of illuminating SFX barrel tips that affix to the wand and produce red light. It exhibits signs of wear throughout from age and use. Dimensions: 34" x 21" x 7" (86.5 cm x 53.75 cm x 17.75 cm)

Contains electronic components; see notice in the Buyer's Guide.

**Estimate: \$10,000 - 20,000**

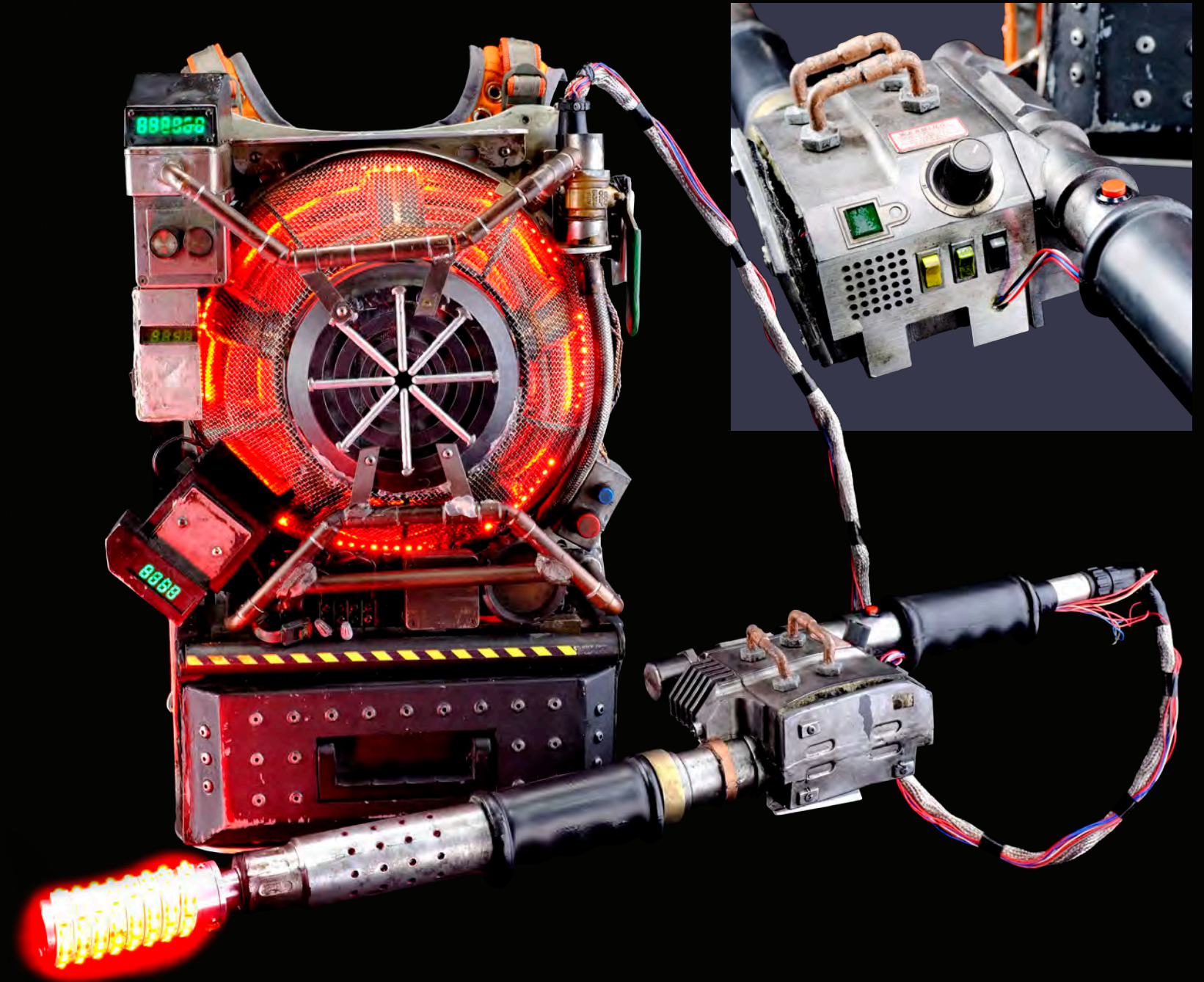

**176**  
**Light-Up V-3 Style Proton Pack**  
**Ghostbusters (2016)**

A light-up V-3 style proton pack from Paul Feig's supernatural comedy Ghostbusters. A new team of paranormal investigators (as played by Kristen Wiig, Melissa McCarthy, Leslie Jones, and Kate McKinnon) wore the final iteration of their specially-created backpacks, which gave them the ability to contain and catch ghosts. 'V-3' was the production name for this model of pack, with the 'V-2' being the earlier backpack-style and the 'V-1' presumably the non-backpack 'proton box' first built by the Ghostbusters in the film.

This proton pack consists of a metal backing frame affixed with adjustable gray and orange nylon straps and a series of decorative details. These details include a metal-mesh dome-like feature over a series of coils; metal and nylon cables and wiring; several metal circuitry plates; a pressure gauge; several control boxes featuring levers and knobs; and a black plastic box with decorative studs. Attached to the pack via a series of cables is the pack's rubber "wand", which can be affixed to the pack via magnets.

Activating a pair of battery operated switches on the pack will cause the coiled cables to illuminate as well as several of the control boxes. The battery-operated wand features several lights and an illuminating barrel which can be activated via a switch and trigger on its body and grip. Also included in the lot are two sizes of illuminating SFX barrel tips that affix to the wand and produce red light. It exhibits signs of wear throughout from age and use. Dimensions: 31" x 15" x 11" (78.5 cm x 38 cm x 28 cm)

Contains electronic components; see notice in the Buyer's Guide.

**Estimate: \$10,000 - 20,000**





**177**  
**Dr. Abby Yates' Light-Up P.K.E. Meter**  
**Ghostbusters (2016)**

Dr. Abby Yates' light-up P.K.E. meter from Paul Feig's supernatural comedy Ghostbusters. Yates (as played by Melissa McCarthy) used a ghost detection tool of her own design in order to seek out unexplained activity with her team of paranormal investigators.

This lot consists of a black and gray plastic and metal meter device with a contoured hand grip, a small LED screen and a series of buttons and switches. Pressing a button on the front causes a pair of accents on the antenna at the top of the device to illuminate. Also included is a replacement antenna. This meter exhibits signs of wear throughout from age and use. Dimensions: 18.5" x 5" x 2.5" (47 cm x 12.75 cm x 6.5 cm)

Contains electronic components; see notice in the Buyer's Guide.

**Estimate: \$3,500 - 7,000**

**178**  
**Light-Up Ghost Chipper**  
**Ghostbusters (2016)**

A light-up ghost chipper from Paul Feig's supernatural comedy Ghostbusters. After a conversation with Mayor Bradley (as played by Andy Garcia), Dr. Jillian Holtzmann (as played by Kate McKinnon) created several new weapons to combat New York City's ghosts, including a device which sucked in and shredded them.

This gray plastic and resin "chipper" features a pair of hand-grips and openings at the front and rear. Pressing a 9 volt battery-operated button on the bottom of the device activates a series of red, white, and blue lights. It exhibits signs of wear and use including some damage to the hand-grips and separation on one of the top details. Dimensions: 14" x 7" x 7" (35.5 cm x 17.75 cm x 17.75 cm)

Contains electronic components; see notice in the Buyer's Guide.

**Estimate: \$2,000 - 4,000**

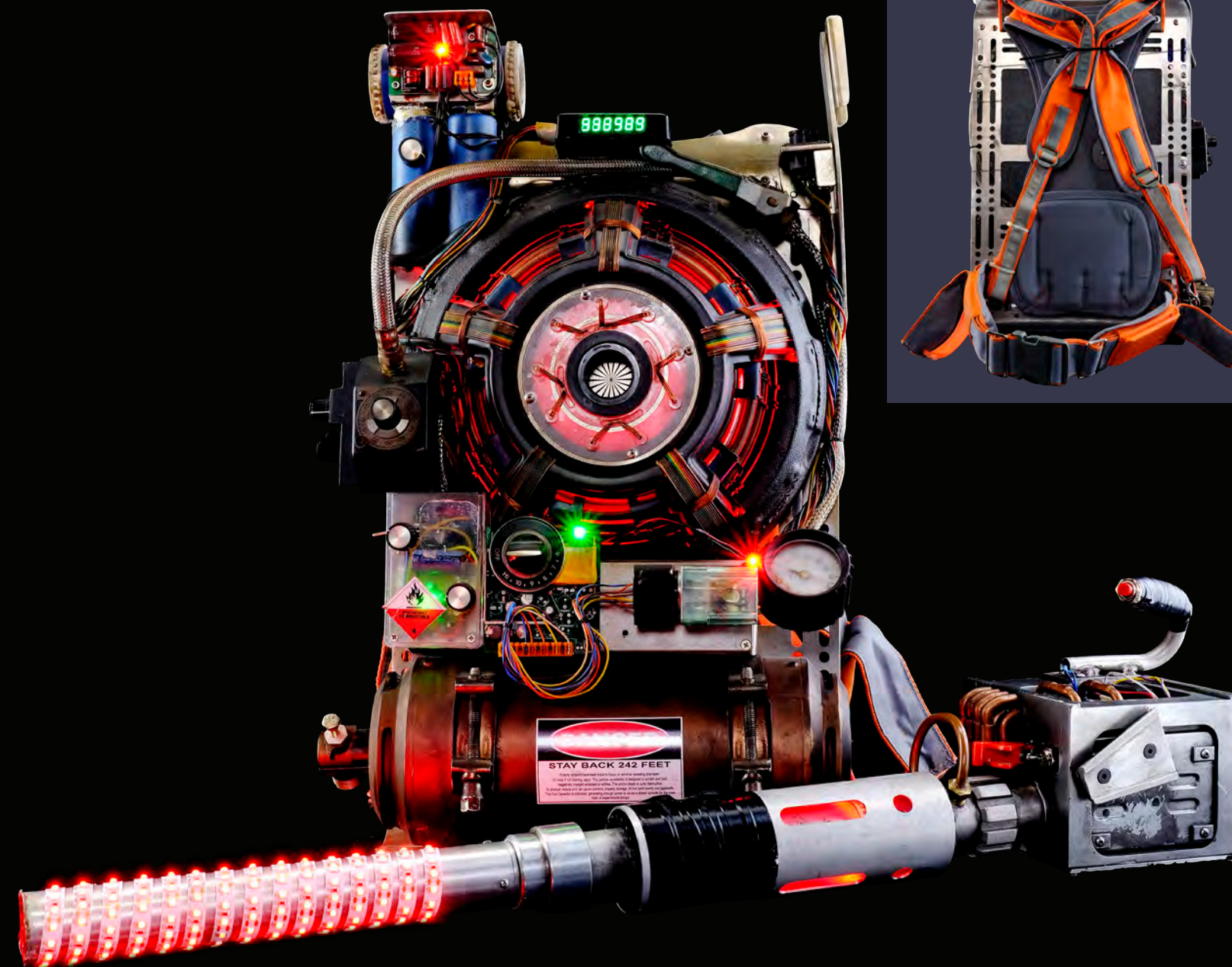
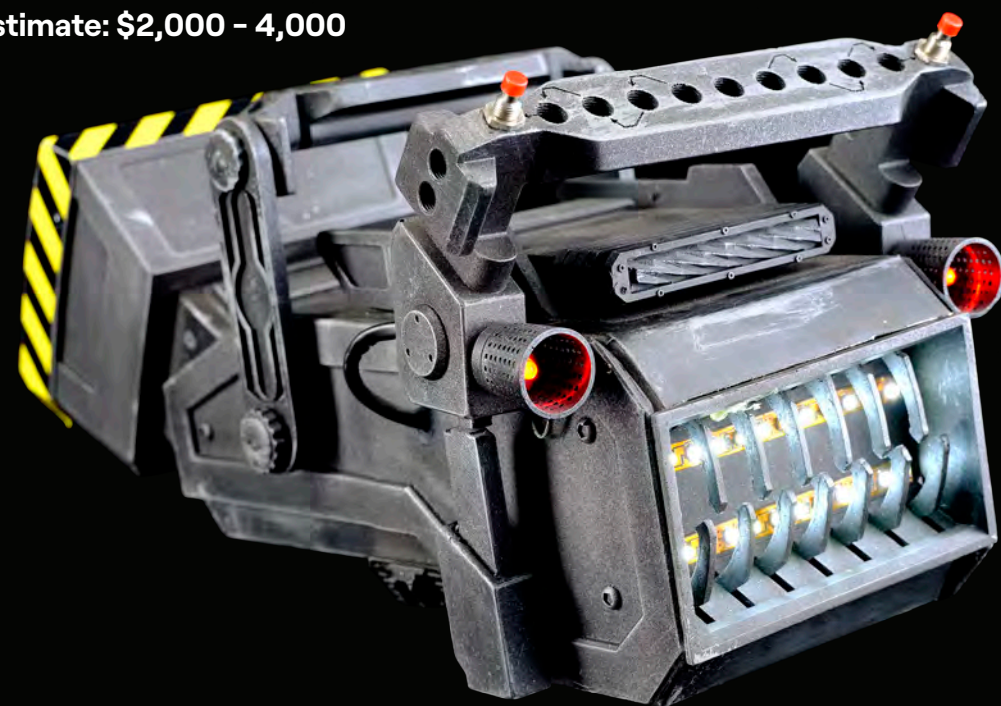

**179**  
**Light-Up Hero V-2 Style Proton Pack**  
**Ghostbusters (2016)**

A light-up hero V-2 style proton pack from Paul Feig's supernatural comedy Ghostbusters. A team of paranormal investigators wore the first iteration of their specially-created backpacks, which gave them the ability to contain and catch ghosts. This pack features a combustible sticker, which attributes it to Dr. Erin Gilbert (as played by Kristen Wiig). 'V-2' was the production name for the first backpack-style pack seen in the film, with the 'V-3' being the final revised pack and the 'V-1' presumably the non-backpack 'proton box' first built by the Ghostbusters in the film.

This proton pack consists of a metal backing frame affixed with adjustable nylon straps and a series of decorative details. These details include a carbon speaker basket coiled with a series of copper-color wires; metal and nylon cables and wiring; several green circuitry plates; a pressure gauge; several control boxes featuring levers and knobs; and a copper-color metal canister. Pressing a battery-operated switch on the front will cause several multicolored lights on the pack to illuminate.

Also included is the pack's "Wand", which consists of a plastic and metal silver-color box featuring multicolored accents, an activation switch and a metal barrel with a black rubber grip. The wand has a removable illuminating SFX barrel tip that produces red light. This lot exhibits signs of wear throughout from age and use. Dimensions: 25" x 20" x 13.5" (63.5 cm x 51 cm x 34.5 cm)

Contains electronic components; see notice in the Buyer's Guide.

**Estimate: \$10,000 - 20,000**

**180**  
**Light-Up Stunt V-2 Style Proton Pack**  
**Ghostbusters (2016)**

A light-up stunt V-2 style proton pack from Paul Feig's supernatural comedy Ghostbusters. A team of paranormal investigators wore the first iteration of their specially-created backpacks, which gave them the ability to contain and catch ghosts. This pack features a skull sticker, linking it to Dr. Abby Yates (as played by Melissa McCarthy). "V-2" was the production name for the first backpack-style pack seen in the film, with the "V-3" being the final revised pack and the "V-1" presumably the non-backpack "proton box" first built by the Ghostbusters in the film.

This proton pack consists of a metal-color rubber backing frame affixed with a series of decorative details. These details include a carbon speaker basket coiled with copper-color wires and a series of rubber details including circuitry plates, switches and a copper-color canister. Pressing a battery-operated switch on the front will cause several multicolored lights on the pack to illuminate.

Also included is the pack's "Wand," which consists of a silver-color rubber box featuring a series of multicolored accents, an activation switch and a cylindrical barrel. It exhibits signs of wear throughout from age and use, including the wand missing its buttoned handle. Dimensions: 24" x 20" x 8" (61 cm x 51 cm x 20.5 cm)

Contains electronic components; see notice in the Buyer's Guide.

**Estimate: \$3,500 - 7,000**

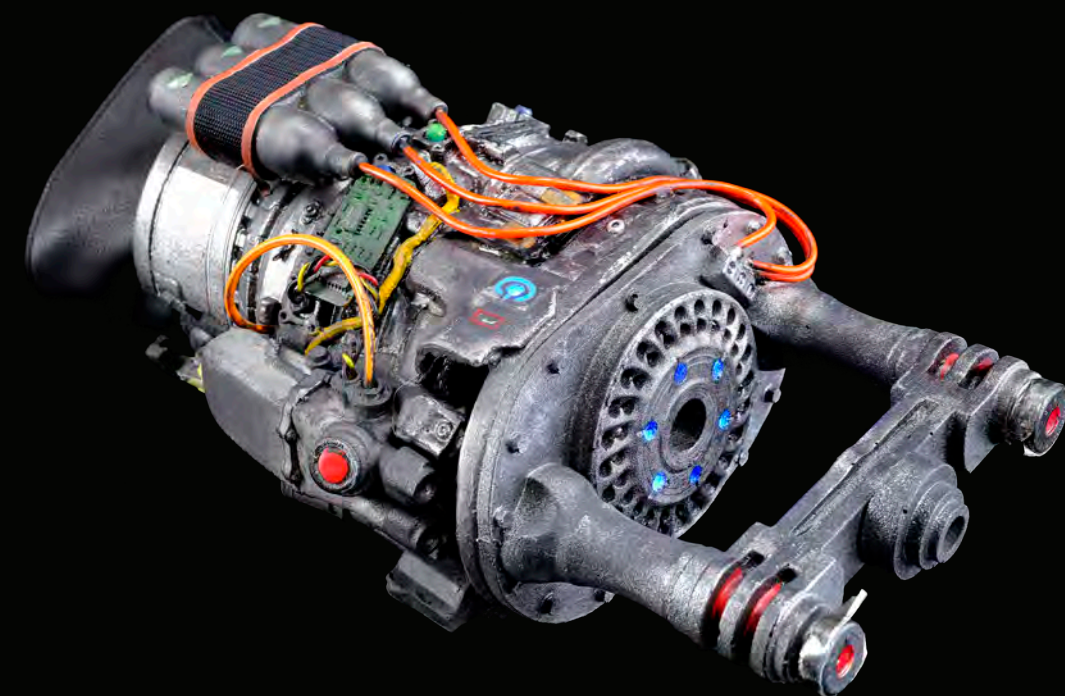

**181**  
**Light-Up Stunt Proton Snare Glove**  
**Ghostbusters (2016)**

A light-up stunt proton snare glove from Paul Feig's Ghostbusters. After a conversation with Mayor Bradley (as played by Andy Garcia), Dr. Jillian Holtzmann (as played by Kate McKinnon) created several new weapons to combat New York City's ghosts, including a glove which dissolved ghosts by punching them.

This hi-tech black and silver-color rubber device features red and orange wire details throughout the exterior and a black neoprene and nylon glove on the interior with a 9V battery-operated switch that activates red and blue lights on the front. It exhibits scuffing of wear from age and use. Dimensions: 13" x 7" x 4" (33 cm x 17.75 cm x 10.25 cm)

Contains electronic components; see notice in the Buyer's Guide.

**Estimate: \$2,000 - 4,000**

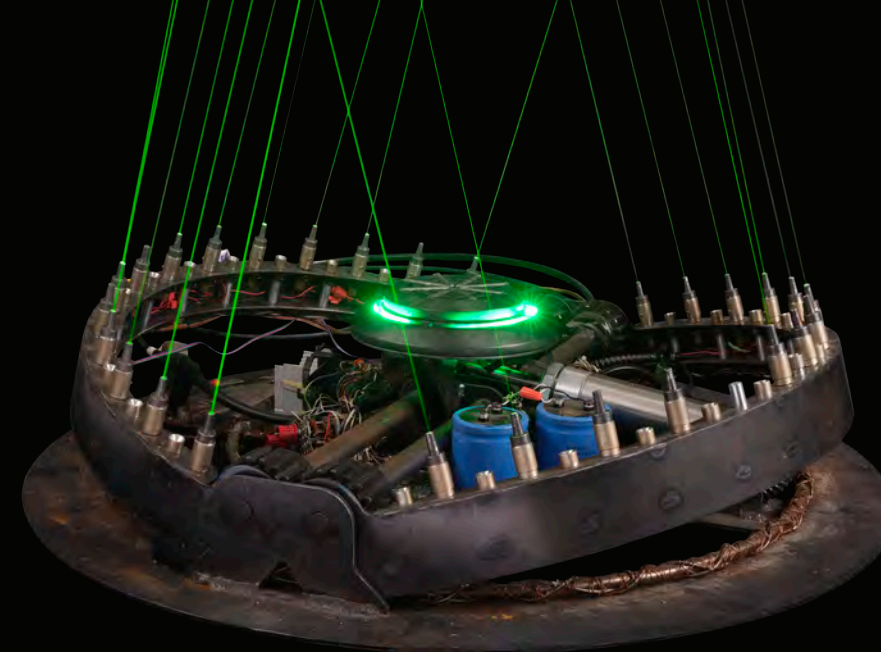

**182**  
**Oversized Light-Up Ghost "Bear" Trap**  
**Ghostbusters (2016)**

An oversized light-up ghost "bear" trap from Paul Feig's supernatural comedy film Ghostbusters. Dr. Jillian Holtzmann (as played by Kate McKinnon) presented it to Drs. Abby Yates (as played by Melissa McCarthy) and Erin Gilbert (as played by Kristen Wigg) during the end credits, claiming that it captured and transported ghosts elsewhere.

This dark gray steel, mechanical foothold trap features led lights inside silver-color metal "teeth," a light-up resin centerpiece with gears, a hose, and a pneumatic pressure connector to spring the trap's jaws together. A separate hose handles smoke aiding visualization of laser beams from the teeth, and includes a power supply. It exhibits scuffing, rust, a missing tooth, and scratching from use. Dimensions: 37" x 37" x 10" (94 cm x 94 cm x 25.5 cm)

Contains electronics and mechanical components; see electronics and mechanical notices in the Buyer's Guide.

Special shipping required; see notice in the Buyer's Guide.

**Estimate: \$2,000 - 4,000**

**183**  
**Ecto-1 Hood Ornament**  
**Ghostbusters (2016)**

An Ecto-1 hood ornament from Paul Feig's supernatural comedy Ghostbusters. The Ghostbusters heavily modified a hearse, complete with a custom ghost-shaped hood ornament, to be their primary means of transport.

This unique ghost-shaped hood ornament was created by Shawn Thorsson under the direction of concept artist Peter Rubin, cast in resin from a mold made from a 3D print of Rubin's digital model, and painted to simulate chrome. In the base of the ornament is a threaded metal connector for attaching it to the vehicle. The hood ornament exhibits paint chipping throughout. Dimensions: 4.5" x 2.75" x 4" (11.5 cm x 7 cm x 10.25 cm)

**Estimate: \$3,500 - 7,000**



**184**  
**Battle of Carthage Shield**  
**Gladiator (2000)**

A Battle of Carthage shield from Ridley Scott's historical epic Gladiator. The gladiators reenacted the Battle of Carthage with Maximus Decimus Meridius (Russell Crowe) cast as a Carthaginian "barbarian."

This shield is constructed from plywood with a canvas cover, gold-color trim, a large silver-color metal dome mounted to the center, and a wooden handle on the reverse. The canvas is hand-painted with a white and yellow Carthaginian over a Roman-styled crest with gold-color metal trim. Production drilled holes for the installation of embedded arrows. It exhibits scratches, tarnishing, paint flaking and chipping from production use. 26" x 39" x 0.5" (66.25 cm x 99.25 cm x 1 cm)

**Estimate: \$2,500 - 5,000**

**185**  
**General Maximus'**  
**(Russell Crowe) Screen-Matched Hero**  
**Dress Cuirass**  
**Gladiator (2000)**

General Maximus' (Russell Crowe) screen-matched hero dress cuirass from Ridley Scott's Academy Award®-winning epic *Gladiator*. Maximus wore his dress cuirass when surveying his troops and meeting with the Emperor following the battle of Germania. The cuirass screen matches through the wear pattern of the wolf crest, distressing marks, and leather folding on cuirass matches to when Emperor Marcus Aurelius (Richard Harris) asked him to become the next emperor, and finally when Maximus talked with Lucilla (Connie Nielsen) about the emperor in the courtyard.

Two styles of Maximus cuirass were created for filming: hero versions that were fiberglass-cast shells wrapped in leather, and lightweight cast foam versions for stunts and action sequences. This hero-style cuirass consists of a leather-covered fiberglass breastplate, backplate, leather connecting straps and shoulder detailing, and leather skirt straps at the waist. It features cast metal breastplate embellishments permanently affixed to the armor. The wolf crest on the chest is the same sculpture seen on General Maximus' gold battle armor. The breastplate connects to the backplate at the shoulders via leather cords that are tied into punched holes, and above the hips via dual leather buckles. The bottom of the cuirass features leather pteruges with metal details at the very ends also permanently affixed to the armor.

The film's costume designer Janty Yates stated that it was Crowe's idea to add embellishments to the cuirass breastplate. *Gladiator* was one of the most successful films of 2000 and places frequently on lists such as *Empire's* 100 Best Movies Of All Time. This screen-matched piece is one of the few hero cuirass in circulation and represents three of the five Academy Award categories that *Gladiator* won: Best Picture, Best Actor, and Best Costume Design. This piece has been lightly intentionally distressed to appear aged. This lot exhibits crease marks and misshapen pteruges.

**Estimate: \$80,000 - 160,000**

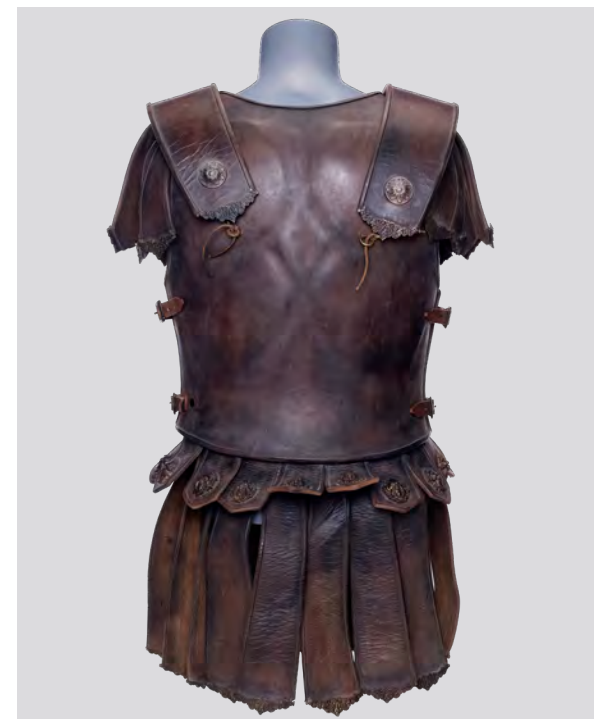

**186**  
**Maximus' (Russell Crowe) Tigris of Gaul Battle Ax**  
**Gladiator (2000)**

Maximus' (Russell Crowe) Tigris of Gaul Battle Ax from Ridley Scott's Academy Award®-winning epic Gladiator. Upon gaining fame within the Colosseum, general-turned-slave Maximus (Russell Crowe) was forced to battle Tigris of Gaul, a rare undefeated champion of the arena.

Made of resin and foam cast over a metallic support rod, the prop ax features a curved head with a short spike protruding from the butt. Extending from the ax head is a ribbed handle with rounded rivets around the grip. This piece has been painted silver- and gold-color, giving it a metallic appearance. It exhibits wear due to production use with minor blemishes to the paint and a missing pommel tip which was damaged on set. Dimensions: 33" x 12.25" x 1.5" (84 cm x 32 cm x 4 cm)

**Estimate: \$25,000 - 50,000**



**187**  
**Assorted One-Eyed Willy's Treasure**  
**The Goonies (1985)**

One-Eyed Willy's assorted treasures from Richard Donner's adventure film The Goonies. One-Eyed Willy's long-lost treasure included many coins, pieces of gold, gems, and baubles.

Created by and originally sourced from production, this collection consists of a metal silver-color goblet, a jeweled glass vial, a "melted" gold-color piece, a gold-color metal bar, three Spanish crest detailed metal coins of various styles and sizes finished in gold-color paint, a faux diamond, and one gold-color wire-wrapped faux amber stone ring. Production intentionally distressed the goblet to appear aged and tarnished. This lot exhibits nicks, chipped paint, and glue residue from handling and production use. Dimensions: 6" x 3" x 3" (15.25 cm x 7.75 cm x 7.75 cm)

**Estimate: \$4,000 - 8,000**



**188**  
**Assorted One-Eyed Willy's Treasure**  
**The Goonies (1985)**

One-Eyed Willy's assorted treasure from Richard Donner's adventure film The Goonies. One-Eyed Willy's long-lost treasure included many coins, pieces of gold, gems, and baubles.

Created by and originally sourced from production, this collection consists of a small silver-color cup, a large "melted" gold-color metal piece, three Spanish crest detailed metal coins of various styles and sizes finished in gold-color paint, a faux diamond, a faux amethyst, and one dark brown bejeweled ornate metal brooch. Production intentionally distressed the items to look aged and tarnished. This lot exhibits nicks, chipped paint, and glue residue from handling and production use. Dimensions: 4" x 3" x 3" (10.25 cm x 7.75 cm x 7.75 cm)

**Estimate: \$3,000 - 6,000**



**189**  
**Assorted One-Eyed Willy's Coins**  
**and Treasure**  
**The Goonies (1985)**

One-Eyed Willy's assorted coins and treasure from Richard Donner's adventure film The Goonies. One-Eyed Willy's long-lost treasure included many coins, pieces of gold, gems, and baubles.

Created by and originally sourced from production, this collection consists of three "melted" gold-color metal pieces of various style and size, three Spanish crest detailed metal coins of various styles and sizes finished in gold-color paint, and a faux diamond. Production intentionally distressed the items to look aged and tarnished. This lot exhibits nicks, chipped paint, and glue residue from handling and production use. Dimensions: 3" x 1.25" x 0.5" (7.75 cm x 3.5 cm x 1.25 cm)

**Estimate: \$1,500 - 3,000**





**190**  
**Estelle Getty's Director Chair**  
**The Golden Girls (1985-1992)**

Estelle Getty's personal director's chair from the production of the comedy series The Golden Girls. Getty starred on the series as Sophia Petrillo for 177 episodes.

This folding wood and metal director's chair features a black canvas chairback with a gold-color suede "Estelle" patch on front and gold-color "The Golden Girls" printed on the reverse. Also included is a color photograph of Getty standing with the chair. The chair exhibits minor stains and scuffs from production use and handling, and minor discoloration and stains on the canvas. Dimensions: 33 x 16" x 16" (84 cm x 40.75 cm x 40.75 cm)

**Estimate: \$10,000 - 20,000**



**RICH WEAVER COLLECTION**

The Rich Weaver Collection represents a number of never-before-seen memorabilia from the illustrious personal collection of Emmy® and Golden Globe® award-winning actor Estelle Getty. These rare lots were cherished and carefully preserved for decades by two of Getty's closest confidantes, including her long-time personal assistant and friend Rich Weaver. Consisting of a range of items from beloved , including original costumes from Stuart Little and Brotherly Love, scripts signed and annotated in Getty's own hand from Stop! or My Mom Will Shoot, and her personal director's chairs and crew materials from the hit series Empty Nest and The Golden Girls, this one-of-a-kind Collection offers public access to one of Hollywood's most treasured stars for the first time. Propstore is proud to present the never-before-seen treasures of The Rich Weaver Collection in honor of the legendary Estelle Getty.



**192**  
**Rich Weaver Collection: Sophia Petrillo's (Estelle Getty) Wedding Dress Costume and Signed Scripts**  
**The Golden Girls (1985-1992)**

Sophia Petrillo's (Estelle Getty) wedding dress costume and signed scripts from the comedy series The Golden Girls. In the Season 4 episode "Sophia's Wedding: Part I," Petrillo wore her dress to wed Max Weinstock (Jack Gilford) after the death of his wife.

This lot comes from the collection of Estelle Getty's personal assistant and friend, Rich Weaver. It consists of a beige chiffon-blend, long sleeve wedding dress with lace applique along the bottom, chest and cuffs; four Getty-signed personal final draft scripts for the episode "Sophia's Wedding: Part I," "Sophia's Wedding: Part II," "The One That Got Away," and "There Goes the Bride, Part II;" and four personal final draft scripts labeled "Estelle Getty" for the episodes "The Operation," "Sophia's Choice," "Sister of the Bride," and "There Goes the Bride, Part I." These scripts feature multicolor highlighter and graphite annotations, paperclipped and dog-eared pages, and multicolor revision pages. Included in this lot is a signed memo from co-producer Marsha Posner Williams to the cast and a copy of the National Enquirer with a preview of the wedding episode. This lot exhibits minor discoloration on the dress and minor stains and fold creases on the scripts from storage. Dimensions: (scripts, each) 8.5" x 11" x 0.5" (21.75 cm x 28 cm x 1.5 cm)

**Estimate: \$6,000 - 12,000**

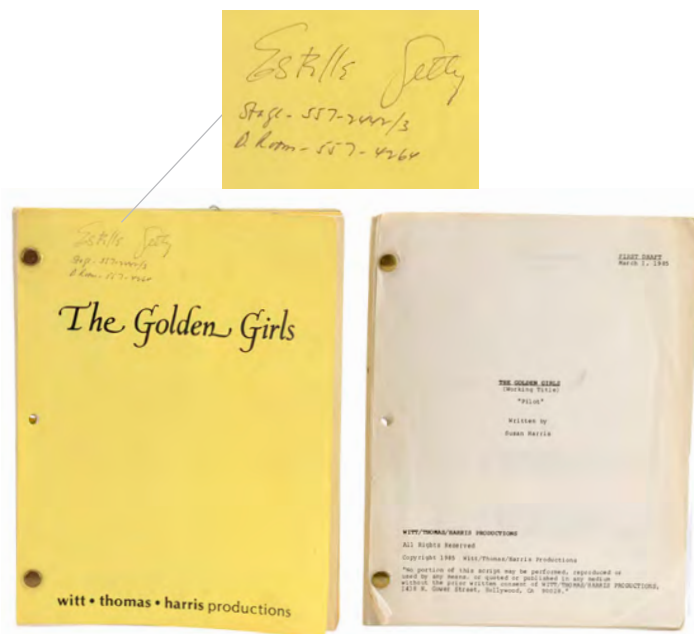

**191**  
**Rich Weaver Collection:**  
**Estelle Getty's First and Final Draft Pilot Scripts with Emmy Award® Nomination Certificate**  
**The Golden Girls (1985-1992)**

Estelle Getty's first and final draft pilot scripts from the comedy-drama series The Golden Girls with an Emmy Award® nomination certificate.

This lot comes from the collection of Estelle Getty's personal assistant and friend, Rich Weaver. It consists of a first draft pilot script dated March 1, 1985 with 53 pages; a 52-page final draft pilot script dated April 12, 1985; and an Emmy Award® nomination certificate for Getty for Outstanding Supporting Actress in a Comedy Series. The scripts feature various handwritten annotations over Getty's lines. This lot exhibits minor discoloration, fold creases and paperclip rust stains. Dimensions: 8.5" x 11" x 0.25" (21.75 cm x 28 cm x 0.75 cm)

**Estimate: \$3,000 - 6,000**

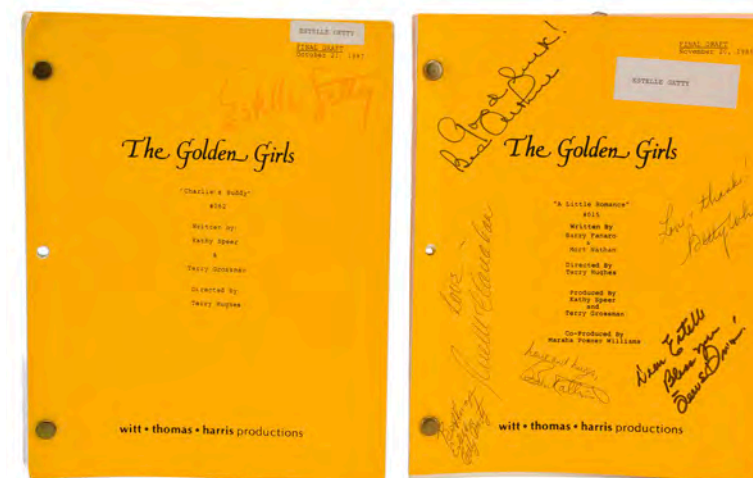

**193**  
**Rich Weaver Collection: Cast-Autographed Script for Estelle Getty and One Personal Autographed Script**  
**The Golden Girls (1985-1992)**

A cast-autographed script for Estelle Getty and one personal autographed script from the comedy series The Golden Girls.

This lot comes from the collection of Estelle Getty's personal assistant and friend, Rich Weaver, and consists of one 51-page final draft script from the Season 1 episode "A Little Romance" dated November 20, 1985 with paperclipped pages and handwritten annotations; and one personal Getty-autographed 46-page final draft script from the Season 3 episode "Charlie's Buddy" dated October 21, 1987 with highlighted annotations. The script "A Little Romance" is cast-autographed by Rue McClanahan, Betty White, Bea Arthur, Billy Barty, Brent Collins, and Jean Dixon. This lot exhibits minor rust stains from the paperclips. Dimensions: 8.5" x 11" x 0.25" (21.75 cm x 28 cm x 0.75 cm)

**Estimate: \$3,000 - 6,000**



**194**  
**Animatronic Rogue Gorilla Mask**  
**Gorillas In The Mist (1988)**

An animatronic rogue gorilla mask from Michael Apted's biopic Gorillas in the Mist. Dian Fossey (Sigourney Weaver) studied gorillas in the Congo, one of which chased her in an early sequence.

Created by special makeup effects artist Rick Baker's Cinovation Studios, this mask consists of an inner fiberglass skull cap with attached mechanical servos and a foam latex face painted to appear lifelike with acrylic eyes, resin teeth, a foam latex tongue, hand-punched fur, and buttons for attaching it to a hair suit. A wire runs out of the back with a switch and plug. The mask is presented on a foam head mounted on a metal rod to a plywood board. The lot exhibits some wear from use and age, including dried and cracked foam latex. Dimensions: 19" x 16" x 19" (48.5 cm x 40.75 cm x 48.5 cm)

Contains electronics; see electronics notice in the Buyer's Guide.

**Estimate: \$5,000 - 10,000**



**195**  
**End Credits Title Boards**  
**The Godfather Part II (1974)**

End credits title boards from Francis Ford Coppola's gangster sequel The Godfather Part II. The film's title cards and end credits were produced by Pacific Title & Art Studio, where this lot originated circa 1982. This particular version differs from the theatrical release, and is believed to be an alternate version either meant for a foreign or home video release.

It consists of four sheets of Nat Mat cardboard taped together, painted black, and applied with white text credits for key cast and crew printed on black backgrounds. The first credit reads "produced and directed by Francis Ford Coppola" and the last reads "Lee Strasberg as hyman roth." The boards are hand-numbered in colored pencil to time with the credit roll and marked "Do Not Shoot." Credits reading "Dean Tavoularis" and "and" have fallen off from age, and the boards exhibit scuffs throughout. Dimensions: 89.5" x 14.25" x 0.25" (227.5 cm x 36 cm x 0.75 cm)

Special shipping required; see notice in the Buyer's Guide.

**Estimate: \$6,000 - 12,000**

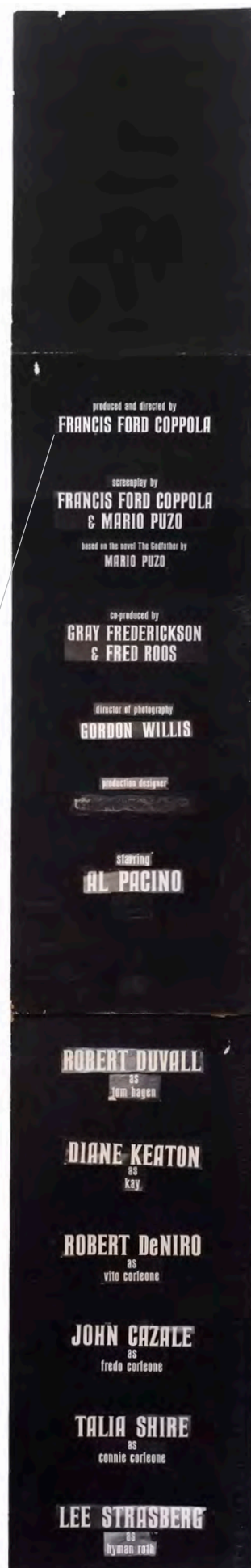

**196**  
**John Coffey's (Michael Clarke Duncan)**  
**Screen-Matched Bloodied Costume**  
**The Green Mile (1999)**

John Coffey's (Michael Clarke Duncan) screen-matched bloodied costume from Frank Darabont's fantasy-drama film The Green Mile. The distressing on the shoulder straps screen-match the overalls Coffey wore when he held the lifeless bodies of Kathe (Evanne Drucker) and Cora Detterick (Bailey Drucker).

This lot consists of a pair of bloody blue cotton jean overalls (50x32); a bloody beige cotton tank top (2XL); a pair of bloodied light brown leather and cork Birkenstock sandals (M 15) attributed to the actor but not seen on screen; and one production tag. This lot exhibits international distressing from production.

**Estimate: \$5,000 - 10,000**



**197**  
**Eduard Delacroix's (Michael Jeter)**  
**Screen-Matched Electric Chair Skullcap**  
**The Green Mile (1999)**

Eduard Delacroix's (Michael Jeter) screen-matched electric chair skullcap from Frank Darabont's fantasy drama The Green Mile. This skullcap screen-matches to the one Percy Wetmore (Doug Hutchison) placed on Delacroix for his execution, without wetting the sponge that led to a painful death.

This leather and metal headpiece features a yellow foam pad on the underside with an exposed middle that shows the metal plate and center bolt. Production distressed this headdress to appear burned. This lot exhibits foam fragility, snagged threads, and notable residue on the underside. Dimensions: 6" x 6" x 4" (15.25 cm x 15.25 cm x 10.25)

**Estimate: \$4,000 - 8,000**



**198**  
 Director Joe Dante's Gremlin Puppet  
**Gremlins (1984)**

Joe Dante's gremlin puppet from his horror comedy Gremlins. Chaos ensued after Billy Peltzer's (Zach Galligan) mogwai, Gizmo, multiplied and transformed into mischievous gremlins. While puppets from the sequel remain in some private collections, surviving puppets from the first film are exceedingly rare.

Dante won the Best Director 1985 Saturn Award for a film whose depictions of violence helped spur the creation of the PG-13 rating within the Motion Picture Association of America's system, and also inspired various films within the subgenre dealing with antagonistic small monsters.

Originally from Dante's personal collection, this foam hand puppet molded in the shape of a gremlin's upper body is painted brown with stripes, with red and orange acrylic eyes and pointed yellow teeth. The piece has undergone sympathetic restoration, most notably to reattach the head and reposition the arms, and has been mounted with internal supports and an archival body insert onto a black wooden base. A Letter of Authenticity from Dante is included. The puppet exhibits some signs of wear from use and age, including minimal cracking and paint chipping. Dimensions: 17" x 9" x 17.5" (43.25 cm x 23 cm x 44.5 cm)

**Estimate: \$75,000 - 150,000**



**199**  
**Daffy Gremlin Marionette**  
**Gremlins 2: The New Batch (1990)**

A Daffy Gremlin marionette from Joe Dante's horror comedy Gremlins 2: The New Batch. Daffy captured Billy Peltzer (Zach Galligan) in a dentist chair.

Dante's irreverent sequel garnered a cult following for its pioneering receipt of a PG-13 rating, the inclusion of genre stalwarts like Christopher Lee and Robert Picardo, and the introduction of several new Gremlins, including the cross-eyed Daffy.

Created by Rick Baker's Cinovation Studios, this foam latex Daffy puppet is strung to two wooden bars and detailed with a green and brown spotted color scheme. The puppet's face features detailed resin teeth, a painted foam latex tongue, and lifelike acrylic eyes. Daffy's head is detailed with several stalks with interior wire to make them malleable. The marionette is presented hanging on a metal pipe stand that is attached to a black wooden base. This piece has undergone sympathetic conservation and stabilization. This puppet exhibits slight wear, such as cracked foam latex. Dimensions: 17.5" x 17.5" x 50" (44.5 cm x 44.5 cm x 127 cm)

**Estimate: \$40,000 - 80,000**







**200**  
George Mogwai Body with Paint Test Head  
**Gremlins 2: The New Batch (1990)**

A George mogwai body with paint test head from Joe Dante's horror comedy sequel Gremlins 2: The New Batch. After the mogwai Gizmo got water on him from a broken water fountain, George and his fellow mogwai were spawned and soon developed into a new infestation of gremlins that quickly took over the Clamp Center.

Rick Baker and his team created the creature effects for the sequel, which faced mixed critical reception following its debut. Between its levity for a PG-13 rating, and the addition of genre performers Christopher Lee and Robert Picardo, the film garnered a cult following in the years after its release.

This lot consists of a cast plaster and faux fur George mogwai paint-test head and a foam body with a faux fur covering and painted foam latex hands and feet, assembled to form a complete George for display and mounted to a black metal pipe fitted to a black acrylic display stand. The foam latex exhibits minimal cracking and paint loss from age. Dimensions: 10" x 5" x 10.5" (25.5 cm x 12.75 cm x 26.75 cm)

**Estimate: \$15,000 - 30,000**



**201**  
Hand-Painted Brian Flora St. Agnes  
Cathedral Gargoyles Matte Painting  
**Gremlins 2: The New Batch (1990)**

A matte painting of St. Agnes Cathedral gargoyles hand-painted by Matte World artist Brian Flora for Joe Dante's horror comedy sequel Gremlins 2: The New Batch. The bat gremlin attacked Mr. Futterman (Dick Miller) outside St. Agnes Cathedral before retreating, covered in cement, to dry into a gargoyle. The sequence was achieved with similar matte paintings, though this painting is believed not to have appeared in the final cut.

This painting depicting eight distinguishable gargoyles amongst the spires, vaults, and arcades of St. Agnes is rendered in mixed media on black-framed glass and hand-marked "FG-2" in the upper right corner. It exhibits chipped paint, scratches, lifted tape, and smudging. Dimensions: 49.5" x 61" x 1" (125.75 cm x 155 cm x 2.5 cm)

Special shipping required; see notice in the Buyer's Guide.

Sold without copyright. See notice in the Buyer's Guide.

**Estimate: \$4,000 - 8,000**



**202**  
Aunt Marie's (Kate Burton)  
Book of Lore  
**Grimm (2011-2017)**

Aunt Marie's (Kate Burton) book of lore from the television fantasy series Grimm. In Season 2, Episode 1, "Bad Teeth," Kelly Burkhardt (Mary Mastrantonio) pulled out Aunt Marie's book to show Nick (David Giuntoli) the entry on Mauvais Dentes.

Originating from production, this lot consists of one hand-made leather-bound book with deckled edges and a leather bookmark. Featuring "Anticus Westia" in yellow paint on the spine, this book has coated and uncoated pages with 60 pages of production-made entries and six production-made inserts. The entries vary in medium from graphite to digital, both hand-rendered and printed. Production purposefully distressed this book to make it appear aged and heavily used. This lot exhibits some discoloration, edgewear, and minor rips and tears. Dimensions: 12" x 15" x 2" (30.5 cm x 38 cm x 5 cm)

**Estimate: \$5,000 - 10,000**

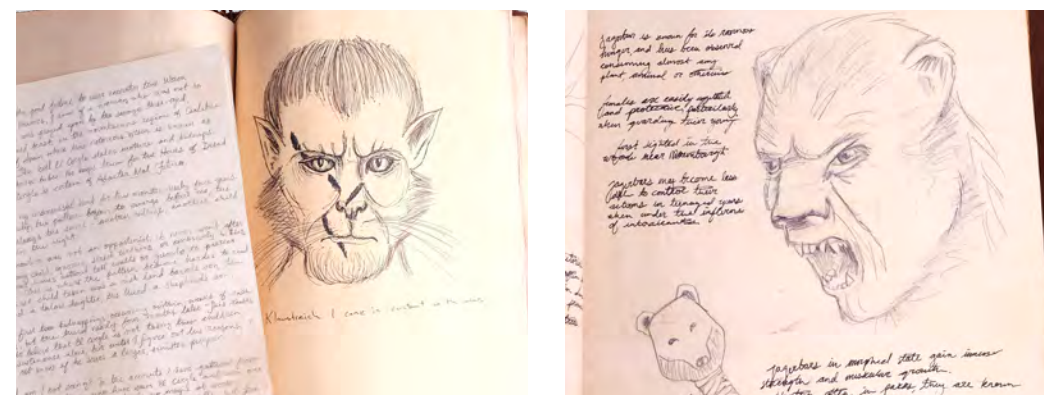



**203**  
**Michael Myers' (Chris Durand) Stunt Mask**  
**Halloween H20: 20 Years Later (1998)**

Michael Myers' (Chris Durand) stunt mask from Steve Miner's slasher sequel Halloween H20: 20 Years Later. The iconic serial killer wore his mask throughout the film as he traveled to California to attempt to finally slay his sister Laurie Strode (Jamie Lee Curtis), now under the new identity of Keri Tate, 20 years after their initial encounter.

Four mask designs were created for the production by KNB EFX Group, Stan Winston Studio, and makeup designer John Carl Buechler, with a CGI mask also used in one scene. Several weeks into shooting, producers wanted to change the appearance of Myers' mask, resulting in the construction of additional masks for reshoots.

This is one of the original KNB masks, most notable for the lack of detail in the ears. Molded from latex rubber based on the William Shatner mask from John Carpenter's Halloween, masks of this style appeared in the DVD release cover, promotional lobby cards, and at various points throughout the film. It is painted peach-color with brown eyebrows, synthetic brown hair, and an intentional split up the back for the performer's ease. The mask exhibits minor holes and blemishes in the rubber and some discoloration on the face.

**Estimate: \$30,000 - 60,000**





**204**  
Laurie Strode's (Jamie Lee Curtis) Stunt Kitchen Knife  
**Halloween H20: 20 Years Later (1998)**

Laurie Strode's (Jamie Lee Curtis) stunt kitchen knife from Steve Miner's slasher sequel Halloween H20: 20 Years Later. Laurie frantically threw several knives at Michael Myers (Chris Durand) as he stalked her in a kitchen, and this style of knife was seen embedded in the door frame.

This lot consists of one production-made knife. Composed of polyurethane painted a metallic gray to resemble steel, this knife has a sculpted handle and is painted brown to resemble wood with aluminum rivets attached. It has a studio inventory barcode adhered to one side of the handle. This lot exhibits discoloration, some bending in the blade's edge, notable paint marks, and notable residue on the handle. Dimensions: 13" x 1.75" x 1" (33 cm x 4.5 cm x 2.75 cm)

**Estimate: \$3,000 - 6,000**

**205**  
Stunt Cable-Controlled Harry Mask  
**Harry And The Hendersons (1987)**

A stunt cable-controlled Harry mask from William Dear's family comedy Harry and the Hendersons. The Henderson family struggled to keep their new friend a secret when they returned home from vacation with a Bigfoot they named Harry (Kevin Peter Hall).

Created by creature designer Rick Baker's Cinovation Studios, this latex Sasquatch mask is hand-punched with hair on the scalp and face, inset with acrylic teeth, and outfitted with numerous cable controls designed to operate the creature's facial features. The mask rests on an original production biscuit-foam headstand mounted to a wooden base. It comes with its original bespoke production road case, which includes a sticker identifying the piece as a stunt mask. The lot exhibits some wear to the foam latex, which has hardened and become brittle in some areas. Dimensions: (mask) 12" x 15" x 16" (30 cm x 38 cm x 41 cm); (road case): 18.75" x 19.75" x 25.5" (48 cm x 50 cm x 65 cm)

Contains mechanical components; see notice in the Buyer's Guide.

**Estimate: \$5,000 - 10,000**

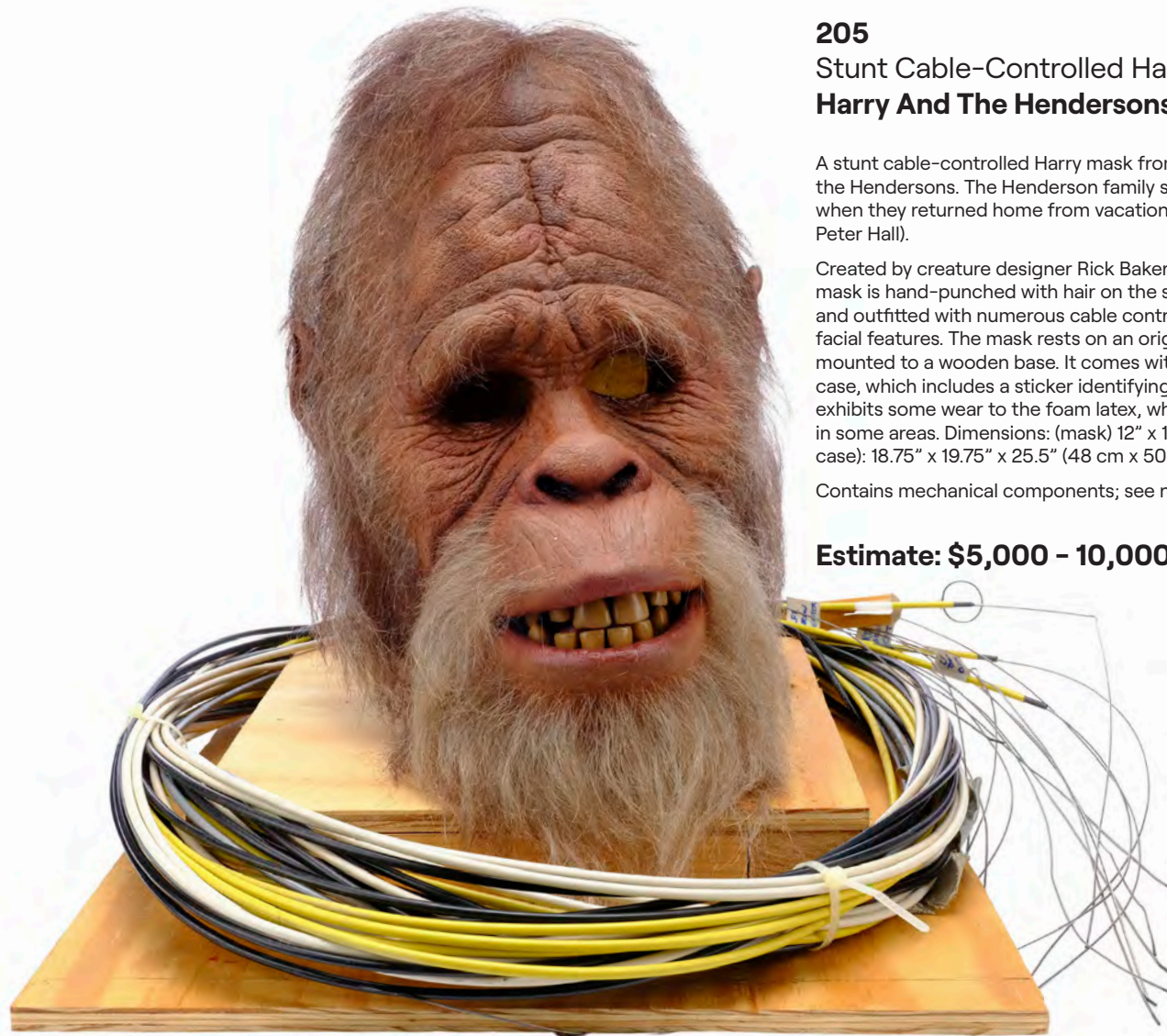

# Propstore

# Wanted

## Props, Costumes and Artifacts from Movies and Television

Sell Your Memorabilia with Propstore to Maximize Your Return

### Back to the Future Part II (1989) Michael J. Fox-autographed Hoverboard

sold for \$506,250

incl. bp



Propstore CA Bond # 72858GU4116

[propstore.com/sell](https://propstore.com/sell)



206

Harry Potter's (Daniel Radcliffe)  
Distressed Costume with Glasses

**Harry Potter And The Chamber Of Secrets (2002)**

Harry Potter's (Daniel Radcliffe) distressed costume with glasses from Chris Columbus' fantasy-adventure film Harry Potter and the Chamber of Secrets. Potter wore his costume as he fought against Tom Riddle's (Christian Coulson) giant Basilisk snake in the mysterious Chamber of Secrets hidden below Hogwarts School of Witchcraft and Wizardry.

This lot consists of a dark gray polyester-blend Gryffindor hooded cloak with a Gryffindor house patch labeled "Daniel Radcliffe 15215 Harry Potter: Wizard Harry Potter 2"; a white cotton button down shirt (size 14); a red and gold-color polyester Gryffindor necktie; a gray wool blend V-neck sweater with a red and gold-color Gryffindor trim; gray polyester blend trousers (size 30) marked "D. Radcliffe" with a black leather belt; black leather suede shoes marked "7M EC"; and a pair of Potter's iconic round metal frame glasses. The glasses may have also been used in the first film. This lot exhibits intentional distressing throughout, such as mud on the cloak, sweater, and pants, and stage blood applied to the shirt around the collar and cuffs.

**Estimate: \$75,000 - 150,000**



**207**

Harry Potter's (Daniel Radcliffe) Wand  
**Harry Potter And The Chamber Of Secrets (2002)**

Harry Potter's (Daniel Radcliffe) wand from Chris Columbus' fantasy adventure sequel Harry Potter and the Chamber of Secrets. Potter wielded the wand he obtained at Ollivanders throughout the film, including in his battle with the Basilisk in the Chamber of Secrets.

This brown-stained wooden wand with a smooth, curved handle may have also been used in Harry Potter and the Sorcerer's Stone. Also included is a yellow box added to the lot for storage. The wand exhibits minor scuffs from production use and the box features a notable loss of adhesion. Dimensions: 3.25" x 14.5" x 1.5" (8.5 cm x 37 cm x 4 cm)

**Estimate: \$25,000 - 50,000**

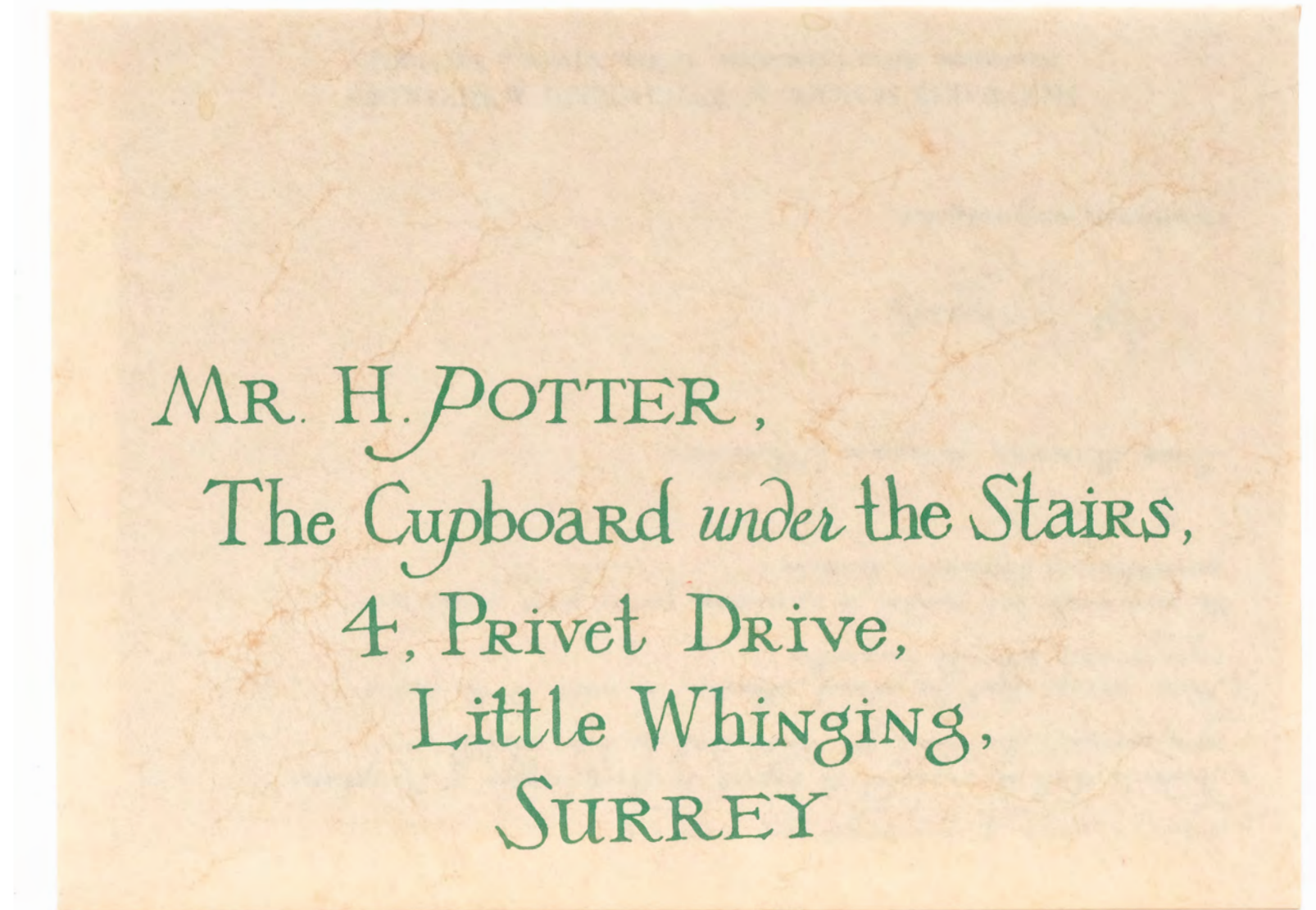
**208**

Harry Potter's (Daniel Radcliffe)  
 Hogwarts Acceptance Letter with Wax Seal  
**Harry Potter And The Sorcerer's Stone (2001)**

Harry Potter's (Daniel Radcliffe) Hogwarts acceptance letter from Chris Columbus' fantasy film Harry Potter and the Sorcerer's Stone. Owl post inundated the Dursley household with letters informing Harry Potter (Daniel Radcliffe) of his acceptance into Hogwarts, despite his Uncle Vernon's (Richard Griffiths) best efforts to hide or destroy them.

This sealed envelope is made from marble-effect paper, with Harry's address printed in green on the front of the envelope and the Hogwarts crest on the reverse. The envelope features a real red wax Hogwarts seal, unlike the many entirely printed versions that were also used in the scene, and there is a letter contained within. This letter exhibits a crack and a small chip present on the wax seal. Dimensions: 5.25" x 7.25" (13 cm x 18 cm)

**Estimate: \$10,000 - 20,000**

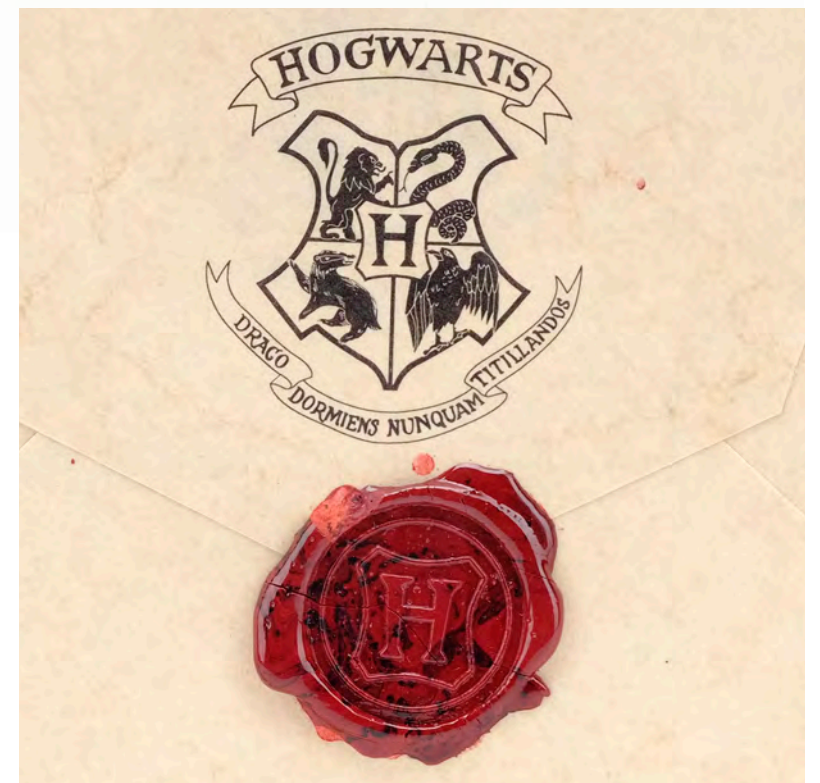

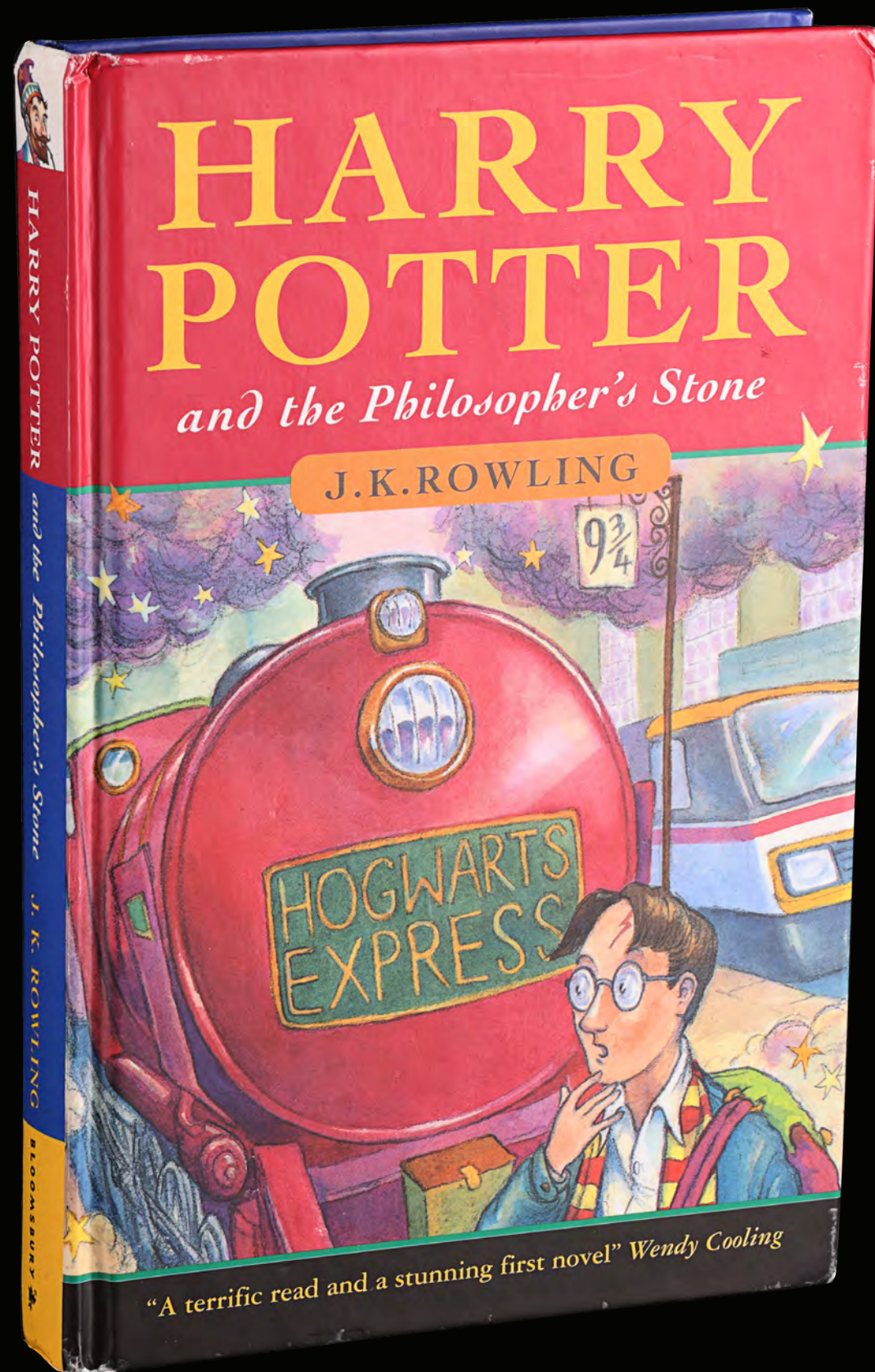

**209**  
 First Edition Hardback Book Δ  
**Harry Potter And  
 The Philosopher's Stone (2001)**

A first edition hardback copy of J.K. Rowling's novel Harry Potter and the Philosopher's Stone. The Philosopher's Stone was the first in Rowling's Harry Potter series, which followed the adventures of a young wizard at Hogwarts School of Witchcraft and Wizardry. It became one of the best-selling books of all time, sparking a worldwide phenomenon.

This copy is one of an initial run of just 500 hardback issues - the first ever printed - many of which were issued directly to libraries. Bloomsbury published it in 1997, and "10 9 8 7 6 5 4 3 2 1" features on the publisher's imprint page. There are two errors in the book which are unique to the first edition. Firstly, the rear cover displays a misspelling of "Philosopher's" as "Philospher's". Secondly, on page 53, the text "1 wand" is repeated twice on a list of equipment.

The back cover showcases artwork (by illustrator Thomas Taylor) of an eccentric wizard not mentioned in any of the books, who was based on the illustrator's father. Eventually, the publishers asked for the portrait to be changed to Hogwarts headmaster Professor Dumbledore. The book exhibits signs of wear on the dust jacket and there is a small tear on the publisher's imprint page, while the pages display some signs of discoloration. However, the lot remains in overall excellent condition, considering its age. Dimensions: 8" x 5.25" x 0.75" (20.5 cm x 13.5 cm x 2 cm)

**Estimate: \$100,000 - 200,000**

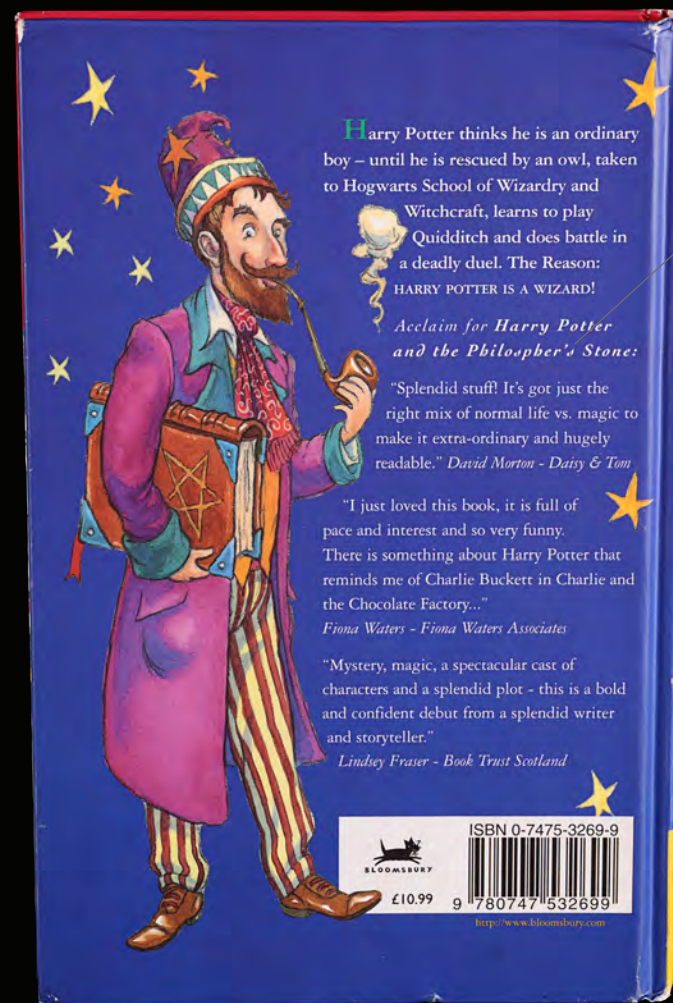
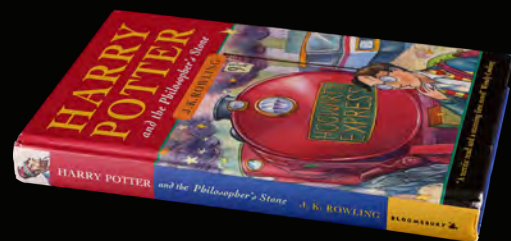

or Harry Potter  
 Philosopher's  
 aff! It's got in

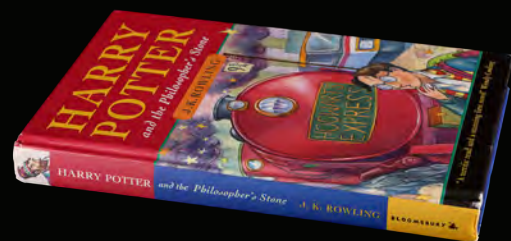
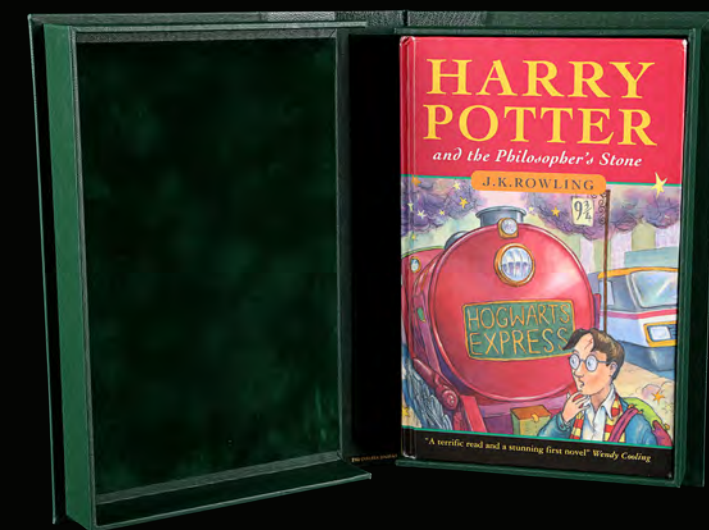

DIAGON ALLEY 53

Fantastic Beasts and Where to Find Them by Newt Scamander  
 The Dark Forces: A Guide to Self-Protection by Quentin Trimble

Other Equipment  
 → 1 wand  
 1 cauldron (pewter, standard size 2)  
 1 set glass or crystal phials  
 1 telescope  
 1 set brass scales  
 → 1 wand  
 Students may also bring an owl OR a cat OR a toad

PARENTS ARE REMINDED THAT FIRST YEARS ARE NOT ALLOWED THEIR OWN BROOMSTICKS

'Can we buy all this in London?' Harry wondered aloud.  
 'If yeh know where to go,' said Hagrid.

All rights reserved; no part of this publication may be reproduced or transmitted by any means, electronic, mechanical, photocopying or otherwise, without the prior permission of the publisher

First published in Great Britain in 1997  
 Bloomsbury Publishing Plc, 38 Soho Square, London W1V 5DF

Copyright © Text Joanne Rowling 1997  
 Copyright © Cover illustration Thomas Taylor 1997

The moral right of the author has been asserted  
 A CIP catalogue record of this book is available from the British Library

ISBN 0 7475 3274 5 Paperback  
 0 7475 3269 9 Hardback

Printed and bound in Great Britain by Clays Ltd, St Ives plc

10 9 8 7 6 5 4 3 2 1



**210**  
 Uncorrected Proof Copy  
 of Harry Potter and the  
 Philosopher's Stone Δ  
**Harry Potter And The  
 Philosopher's Stone (2001)**

An uncorrected proof copy of J.K. Rowling's novel Harry Potter and the Philosopher's Stone. This was the debut novel in Rowling's Harry Potter series, which told the story of a young wizard named Harry and his adventures at Hogwarts School of Witchcraft and Wizardry. It became one of the best-selling books of all time, sparking a worldwide phenomenon. Proof copies are created by publishers and sent to reviewers, book shops and influencers to create a buzz around a book prior to publication.

Approximately 200 copies of this proof first edition book were published. It includes an error on the title page, with Rowling's name misspelt as "J.A. Rowling". The book has only very light handling wear, with a crease down the spine and some very small spots on the back cover. Dimensions: 7.75" x 5.25" x 0.5" (20 cm x 13.5 cm x 1.5 cm)

**Estimate: \$25,000 - 50,000**

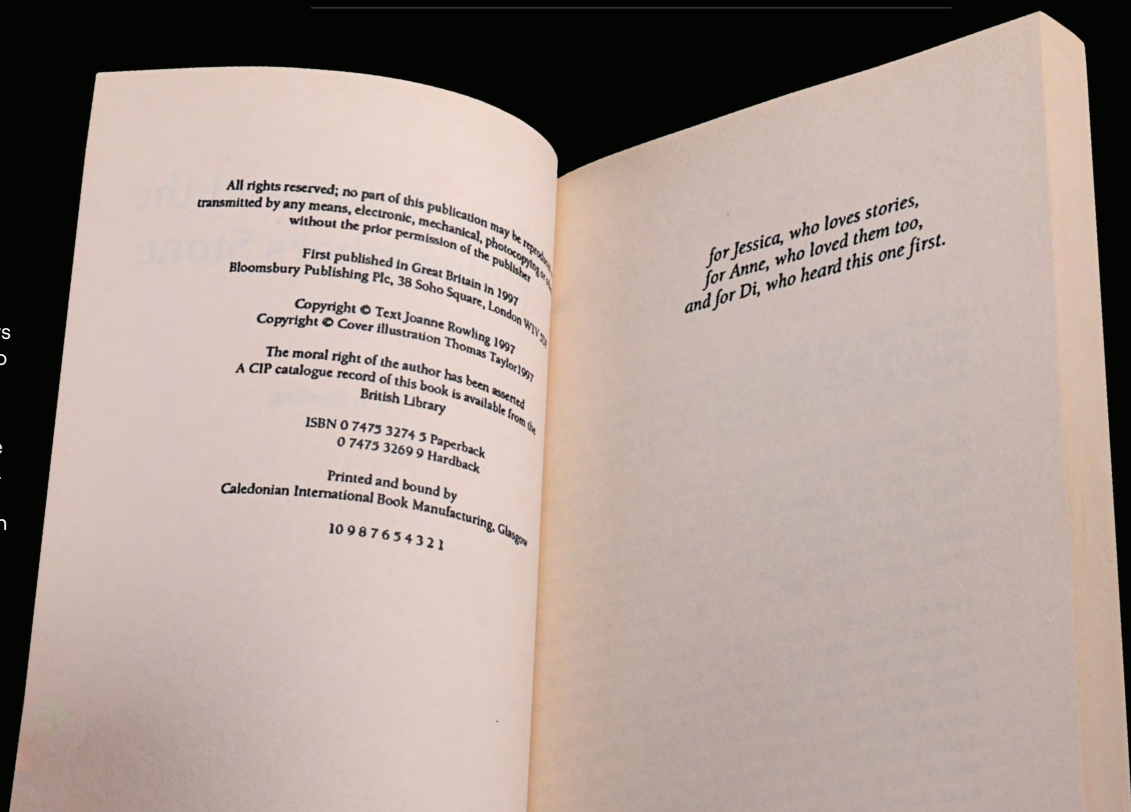

All rights reserved; no part of this publication may be reproduced, stored in a retrieval system, or transmitted by any means, electronic, mechanical, photocopying, recording, or by any information storage and retrieval system, without the prior permission of the publisher.

First published in Great Britain in 1997  
 Bloomsbury Publishing Plc, 38 Soho Square, London W1D 3HE

Copyright © Text Joanne Rowling 1997  
 Copyright © Cover Illustration Thomas Taylor 1997

The moral right of the author has been asserted  
 A CIP catalogue record of this book is available from the British Library

ISBN 0 7475 3274 5 Paperback  
 0 7475 3269 9 Hardback

Printed and bound by  
 Caledonian International Book Manufacturing, Glasgow

10 98 7 6 5 4 3 2 1

*for Jessica, who loves stories,  
 for Anne, who loved them too,  
 and for Di, who heard this one first.*



**211**  
 Victor Crowley's (Kane Hodder)  
 Costume, Mask, and Hatchet  
**Hatchet (2006) / Hatchet III (2013)**

Victor Crowley's (Kane Hodder) costume and mask from Adam Green's horror comedy Hatchet and Crowley's hatchet from B. J. McDonnell's sequel Hatchet III. Supernatural psychopath Crowley wore his overalls and wielded his titular hatchet during his homicidal killing sprees throughout the franchise.

This set consists of a custom-made beige latex cowl and facial appliance affixed to a black display head with several pins; blue denim overalls; black leather boots; and a rubber hatchet with silver-color and simulated-wood accents. The costume exhibits extensive wear and aging deliberately added by production, including blood staining on the boots, blood and holes throughout the jeans, and some cracking on the foam elements of the facial appliances; and the hatchet exhibits scuffing and paint flaking. Dimensions (hatchet): 17.25" x 8.25" x 0.5" (44 cm x 21 cm x 1.5 cm)

**Estimate: \$8,000 - 16,000**

**212**  
 Tinkerbell's (Julia Roberts)  
 Tinkerbell Ears and Screen Test Costume  
**Hook (1991)**

Tinkerbell's (Julia Roberts) Tinkerbell ears and screen test costume from Steven Spielberg's comedy-adventure film Hook. This costume was created during production for Tinkerbell and ultimately not seen on screen.

This lot consists of a purple iridescent top with green tulle, pink applique, and sequins labeled "Columbia Studios Julia Roberts #1 F."; a pair of matching shorts labeled "Columbia Studios Julia F."; a matching arm band; a pair of latex foam glitter ear tips; and one production tag. This lot exhibits minor discoloration.

**Estimate: \$5,000 - 10,000**



**213**  
 Daisy Domergue's (Jennifer Jason Leigh) Bloodied Costume  
**The Hateful Eight (2015)**

Daisy Domergue's (Jennifer Jason Leigh) bloodied costume from Quentin Tarantino's crime-drama film *The Hateful Eight*. Domergue wore her costume as she traveled with bounty hunters John Ruth (Kurt Russell) and Major Marquis Warren (Samuel L. Jackson).

This lot consists of a rust orange wool blend handknit scarf; a brown knit cloche with brown rabbit fur; distressed gray leather boots marked "7 Daisy #2"; taupe leather and black embroidered gloves; a package of gray wool footless tights; an iridescent teal cotton jacket with a gray torso, lace trim, and embroidered flowers labeled "JL #1 bloody"; a matching ankle length skirt; a rust orange ankle length bustle underskirt; a distressed brown leather coat with matching belt, leather buttons, a black bear fur collar, and black cotton lining; a 2" x 3" color continuity photo; and three production continuity tags. This costume exhibits mud, fraying threads, and tears in the gloves from production.

**Estimate: \$4,000 - 8,000**



**214**  
 Sheriff Chris Mannix's (Walton Goggins)  
 Costume and General Smithers (Bruce Dern) Coat  
**The Hateful Eight (2015)**

Sheriff Chris Mannix's (Walton Goggins) costume and General Smithers (Bruce Dern) coat from Quentin Tarantino's crime-drama film *The Hateful Eight*. Mannix wore his costume when he took the deceased General Smithers' coat for warmth.

This lot consists of black leather knee-high boots; black leather gloves (size 9); black elastic suspenders; a black waxed canvas duster with a brown cowhide collar and brown metal buttons; a black suede jacket with metal buttons; a black wool and leather trim vest; a black-and-white stripe button down; gray wool and black- and gold-color stripe pants; a black leather belt with perforated details; a gray and tan wool tie; a black flat brim gambler hat featuring a brown leather band with metal studs and shotgun shell ornaments; a gray wool coat with gold-color metal "CSA" buttons and a hole on the left side with a cloth in stage blood. This lot exhibits mud on the hat, fading cowhide, and fraying edges on the duster.

**Estimate: \$4,000 - 8,000**

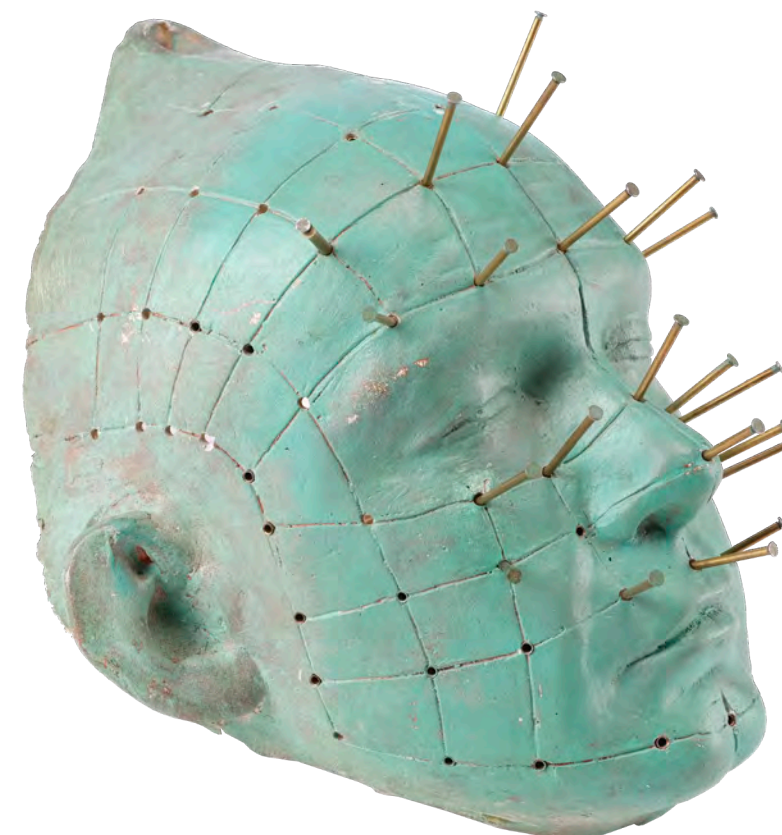

**215**  
 Deleted Scene Pillar of Souls SFX Pinhead Face  
**Hellraiser III: Hell On Earth (1992)**

A Pillar of Souls SFX Pinhead face from Anthony Hickox's horror sequel *Hellraiser III: Hell on Earth*. In a deleted scene montage, Pinhead's (Doug Bradley) face became visible on the Pillar of Souls that J.P. (Kevin Bernhardt) unwittingly purchased as art.

This fiberglass SFX face mask is painted in shades of gray and teal with hollow metal nails inset at the intersections of grid-like cuts and a raised point on the back that forms a loop. White twine designed to push the nails into the head, a process which would then be reversed in post-production to show them "growing out," is attached to the brass-and silver-color nails' openings. The mask exhibits exposed fiber, unsealed edges, missing components, chipping, and notable paint marks. Dimensions: 11" x 8.5" x 7" (28 cm x 22 cm x 18)

**Estimate: \$5,000 - 10,000**



**216**  
 Siamese Twin Cenobite's  
 (Mark and Michael Polish) Chest Piece  
**Hellraiser: Bloodline (1996)**

A Siamese twin Cenobite's (Mark and Michael Polish) chest piece from Kevin Yagher and Joe Chappelle's sci-fi horror film *Hellraiser: Bloodline*. The Siamese twins separated into two and killed a guard when they fused with him.

This lot consists of a polyfill padded foam and black vinyl top with a flesh-color foam rubber chest window. With a high neck collar and long sleeves, this top features a zip back with a self-fastening strip belt at the back to give a more form-fitted fit to the actor. The foam rubber chest piece features a stitch-like patterned scar through the center of it. This lot exhibits some discoloration, foam fragility, and mildew residue.

**Estimate: \$3,000 - 6,000**







**217**  
Automaton Head on Display  
**Hugo (2011)**

An automaton head from Martin Scorsese's adventure drama Hugo on a display. Hugo Cabret (Asa Butterfield) worked on an automaton his father found, before he discovered the automaton's creator was Georges Melies (Ben Kingsley).

This lot consists of one automaton head. Made of plastic painted a shiny chrome-color with matte black eyes, this head features a hollow inside with a brass-color metal hinge at the base of the neck and an internal braided cord. This head comes with a black plastic display base and a clear plastic armature. This lot exhibits scratching, chipped paint, and mild discoloration. Dimensions: 5" x 4" x 6" (12.75 cm x 10.25 cm x 15.25 cm)

**Estimate: \$5,000 - 10,000**

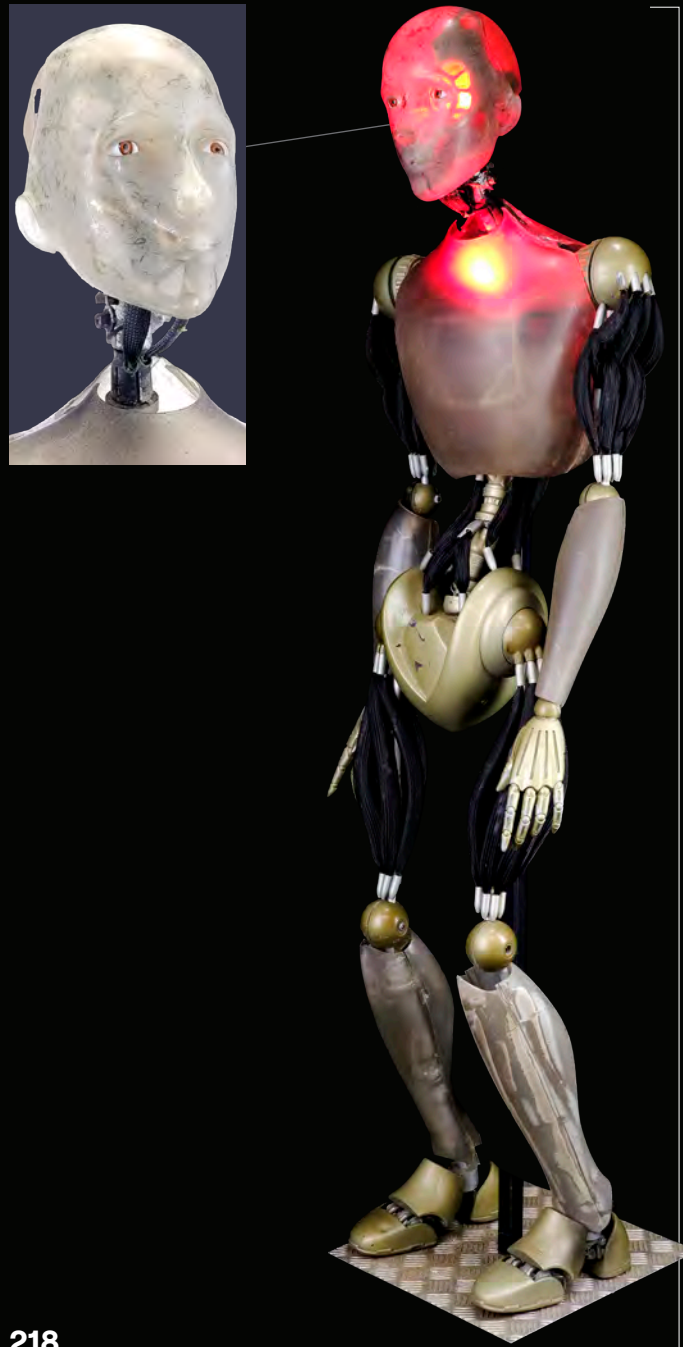

73" (185.5 cm)

**218**  
Full-Size Light-Up NS-5 Robot Display  
**I, Robot (2004)**

A full-size light-up NS-5 robot display from Alex Proyas' sci-fi action film I, Robot. Most of the film's robots were computer generated, but full-size practical models were required for certain scenes, including one which took place in Dr. Lanning's (James Cromwell) laboratory, as well as during the climactic battle between humans and robots.

This robot is constructed from various materials, including cast acrylic plating with a frosted finish, gold-color resin joints, black plastic mesh cords, an internal metal armature, and life-like acrylic eyes with brown irises. It comes on a custom-made metal display stand. A metal switch on the back of the neck activates the red light in the head. It exhibits paint chipping, scratches in the acrylic's frosted finish, cracked acrylic including a broken area on the back of the head, tears in the cords, tape on the chest, and signs of restoration work. Dimensions (displayed): 73" x 19" x 8" (185.5 cm x 48.5 cm x 20.5 cm)

Special shipping required; see special shipping notice in the Buyer's Guide.

Contains electronic components; see notice in the Buyer's Guide.

**Estimate: \$8,000 - 16,000**



Moviestore Collection Ltd / Alamy Stock Photo



1" (2.75)

**219**  
Cobb's (Leonardo DiCaprio) Spinning Top Totem  
**Inception (2010)**

Cobb's (Leonardo DiCaprio) spinning top totem from Christopher Nolan's sci-fi-action film Inception. Cobb held a spinning top as his totem that allowed him to distinguish between the dream-sharing and reality.

This totem is a brown colored, lightly textured, metal spinning top with two pointed ends, one longer to hold the top and a shorter end for the top to balance on as it spins, and a flat circular bodice. This top exhibits minor grime and wear on the bottom from production use. Dimensions: 1" x 1" x 1" (2.75 cm x 2.75 cm x 2.75 cm)

**Estimate: \$15,000 - 30,000**



50" (127 cm)



Paintwork on Model Matches to Still in The Making of Independence Day

**220**  
Photo-Matched 48-Inch Alien Attacker Spaceship Model Miniature  
**Independence Day (1996)**

A photo-matched 48-inch alien Attacker spaceship model miniature from Roland Emmerich's sci-fi action film Independence Day. Attackers, the primary fighter craft of the alien Harvesters, were deployed from the larger City Destroyer and Mothership spaceships. Captain Steven Hiller (Will Smith) took one attacker down and captured the pilot during the first battle.

This lot consists of one Attacker model miniature, a bag of parts, and a magazine for "The Making of Independence Day." Constructed of fiberglass, resin, foam, vacuum-formed plastic components and other multimedia, the miniature features an intricate, multifaceted biomechanical technology-inspired design all over its chassis and was painted in shades of metallic gray, green, and blue. The underside of the spaceship's top was handmarked with the word "Clearance" in blue-black ink. Also included are two wire stands.

During production, two scales of model were crafted, larger and smaller, with this being a larger scale model. Larger scale models such as this piece were used for the crash sequence as well as in the Area 51 model miniature hangar. Additionally, this miniature photo-matches to an image featured in the behind-the-scenes book "The Making of Independence Day."

This model has undergone sympathetic repair and accents were produced to complete the display. This lot exhibits surface pitting from the curing process, chipped paint on some surfaces, minor blemishes, loose components, and notable adhesive marks. Dimensions: 46" x 50" x 22" (117 cm x 127 cm x 56 cm)

**Estimate: \$12,000 - 24,000**

**221**  
Production-Made 24-Inch Alien Attacker Model Miniature  
**Independence Day (1996)**

A production-made, 24-inch alien Attacker model miniature from Roland Emmerich's sci-fi action film Independence Day. Captain Steven Hiller (Will Smith) took one attacker down and captured the pilot during the first battle.

Gifted from the film's lead model maker to the VFX Producer, this Attacker model miniature is made of hollow fiberglass and features an intricate, multifaceted pattern all over its chassis and was hand-painted predominantly in varying shades of metallic green, with bronze-color paint down the ship's panel lines. A small metal mounting point is on the underside and now sits on a custom-made display. Also included is an invitation to the world premiere and a Black Knights VMFA 314 patch. This lot exhibits cracking around the base of the fin on top of the craft. Dimensions: 21.5" x 24.5" x 10" (54.75 cm x 62.25 cm x 25.5 cm)



24.5" (62.25 cm)

**Estimate: \$6,000 - 12,000**

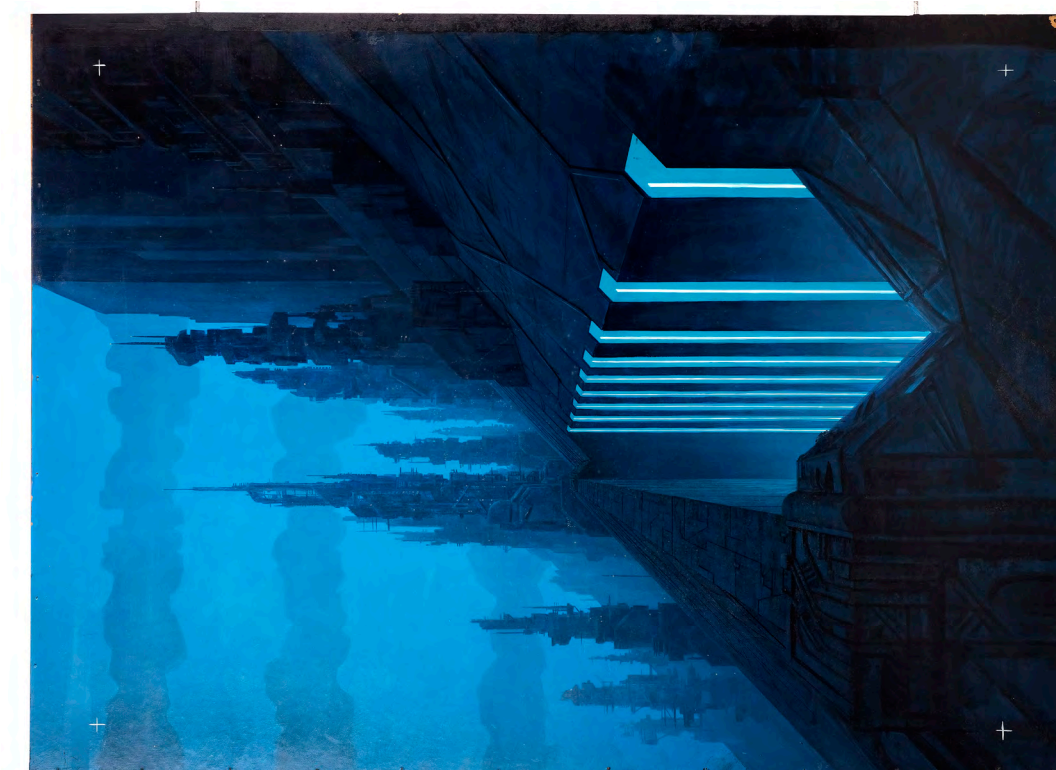

61" (155 cm)

**222**  
Hand-Painted Chris Evans Interior Alien Spaceship Matte Painting  
**Independence Day (1996)**

A hand-painted Chris Evans interior alien spaceship matte painting from Roland Emmerich's sci-fi action film Independence Day. Captain Steven Hiller (Will Smith) and David Levinson (Jeff Goldblum) flew into the Harvesters' mothership to upload a virus.

This lot consists of one oversize matte painting on a wooden board with support panels. It features an image of dark gray architecture with alien-like spires in the background and blue light emanating from within. The four corners also feature hand-marked crosses. This lot exhibits nail holes and splintering wood. Dimensions: 49.5" x 61" x 1" (125.75 cm x 155 cm x 2.5 cm)

Special shipping required; see notice in the Buyer's Guide.

Sold without copyright. see notice in the Buyer's Guide.

**Estimate: \$4,000 - 8,000**



**223**  
 Indiana Jones' (Harrison Ford)  
 Smith & Wesson Mk II Hand Ejector Revolver  
**Indiana Jones And The Raiders Of The Lost Ark (1981)**

Indiana Jones' (Harrison Ford) Smith & Wesson Mk II Hand Ejector revolver from Steven Spielberg's action-adventure film Raiders of the Lost Ark. Indy wielded a Smith & Wesson Mk II as his primary revolver in multiple fight scenes, including the Ravenwood Bar shootout, the Tunisia gunfight, the rescue of Marion Ravenwood (Karen Allen) from the Nazis, and when he shot the Arab Swordsman (Terry Richards) in their iconic duel.

The Indiana Jones franchise's inaugural film became 1981's highest-grossing film in addition to winning numerous Academy Awards® and a BAFTA®. Its success led to Harrison Ford's recognition as a leading man, and in 1999, the US Library of Congress selected the film for permanent preservation in its National Film Registry.

Rented to the production by UK armorer Bapty, this is believed to be one of two Mk II revolvers used by Ford during production at Elstree Studios and the Tunisia set. A different model of revolver, known as the Stembridge, was briefly used during scenes shot in the United States.

This revolver is designed to shoot .455 blanks and stamped with serial number 37891 and gold Smith & Wesson logos. Production also made several modifications, including boring out and shortening the gun's barrel, adding a custom-made ramped front sight, and applying a patina throughout to make it appear well-worn. The revolver features diamond-patterned walnut grips with a swivel lanyard on the underside. Also included are a Bapty Letter of Authenticity and a Certificate of De-Activation from The London Proof House.

This pistol has been sympathetically deactivated, although the hammer, trigger and chamber remain functional, and it exhibits tarnishing, scratching, and minor dents in the grip from production use and handling. Dimensions: 9.5" x 5" x 2" (24.25 cm x 12.75 cm x 5 cm)

Firearm deactivated; see firearm deactivation notice in the Buyer's Guide.

**Estimate: \$100,000 - 200,000**



PARAMOUNT PICTURES / LUCASFILMS / Ronald Grant Archive / Alamy Stock Photo



**224**  
**Set Decorator's Production-Used Screenplay**  
**with Prop and Set Dec Breakdowns**  
**Indiana Jones And The Raiders Of The Lost Ark (1981)**

A set decorator's production-used screenplay with prop and set dec breakdowns from Steven Spielberg's action-adventure film Indiana Jones and the Raiders of the Lost Ark. This set of paperwork was used by set decorator Michael Ford.

This lot consists of a 153-page red vinyl binder marked "MIKE FORD" featuring: a highlighted and handwritten annotated script; an annotated prop budget; a translated list of English-to-German phrases; a vehicle breakdown sheet with copied visuals; black-and-white printed photo references; and various other notes with handwritten annotations. The unique production paperwork featured in this lot have never before been offered. This lot exhibits discoloration and minor stains from age. Dimensions: 10.25" x 13.75" x 1.25" (26 cm x 35 cm x 2.25 cm)

**Estimate: \$4,000 - 8,000**

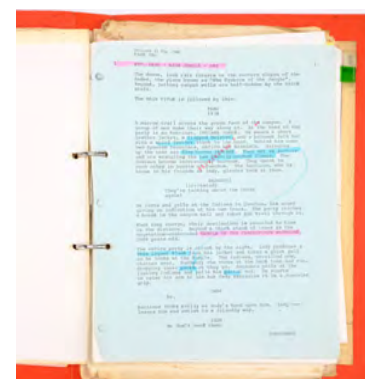
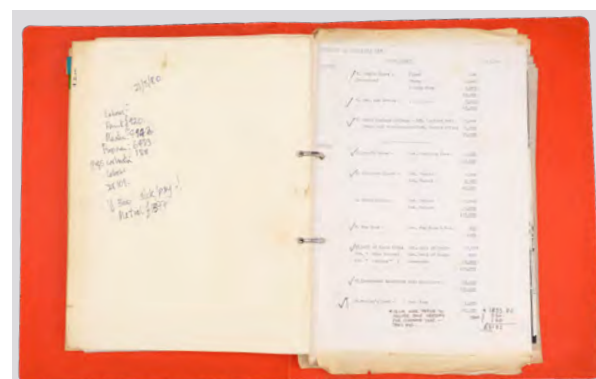
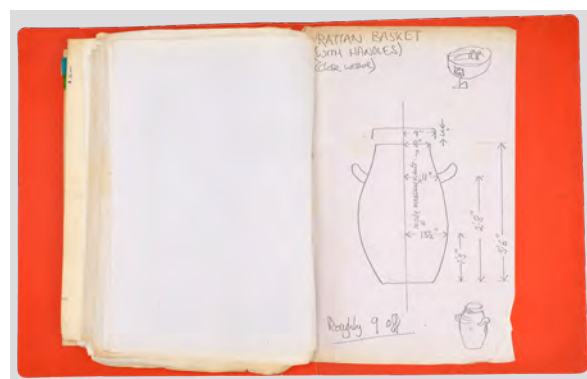

**225**  
**Framed Hand-Painted**  
**Roy Carnon Ark of the Covenant**  
**Concept Artwork**  
**Indiana Jones And The Raiders**  
**Of The Lost Ark (1981)**

Framed Ark of the Covenant concept artwork hand-painted by sketch artist Roy Carnon for Steven Spielberg's action-adventure Raiders of the Lost Ark. Carnon created this illustration for the scene in which Indiana Jones (Harrison Ford) opened a bible to an illustration of the Ark to show government officials, and possibly as general production concept artwork as well. While printed Carnon artwork was used in the bible during filming, it was replaced during reshoots with an insert of artwork by Ralph McQuarrie.

This concept artwork of soldiers surrounding the illuminated Ark is rendered in mixed media on paper and mounted behind glass in a dark brown wooden frame. The paper exhibits some staining, uneven edges, and bending at its bottom corners. Dimensions: 24" x 28" x 1" (61 cm x 71.25 cm x 2.5 cm)

Sold without copyright; see notice in the Buyer's Guide.

**Estimate: \$4,000 - 8,000**



89" (226.25 cm)

**226**  
**Full-Size Well of Souls Sarcophagus Replica Casting**  
**Indiana Jones And The Raiders Of The Lost Ark (1981)**

A casting for a full-size Well of Souls sarcophagus replica from the production of Steven Spielberg's action-adventure film Raiders of the Lost Ark. Indiana Jones (Harrison Ford) encountered sarcophagi and other ancient artifacts, including the Ark of the Covenant, in the Well of Souls.

Circa 1990s, Industrial Light & Magic (ILM) molded new sarcophagi for an unrelated project requiring Egyptian-style props from one of the Raiders sarcophagi preserved in the Lucasfilm Archives. This is an ornately hand-painted fiberglass casting for that mold with wood backing and holes for lifting and brackets for anchoring to walls. It exhibits some scuffing and paint flaking from age and the wood backing is splitting at the bottom. Dimensions: 30" x 19" x 89" (76.25 cm x 48.5 cm x 226.25 cm)

Special shipping required; see notice in the Buyer's Guide.

**Estimate: \$5,000 - 10,000**



**227**  
**William Plumb Collection:**  
**Hand-Painted Witold Dybowski Polish Poster Artwork**  
**Indiana Jones And The Temple Of Doom (1984)**

Poster artwork hand-painted by posterist Witold Dybowski for the 1985 Polish theatrical release of Steven Spielberg's action-adventure sequel Indiana Jones and the Temple of Doom. This comic book-style artwork depicts Indiana Jones (Harrison Ford), Willie Scott (Kate Capshaw), and Short Round (Ke Huy Quan) looming over Mola Ram (Amrish Puri). Dybowski also created iconic style "B" poster artwork featuring Darth Vader's exploding head for the Polish release of Star Wars: Return of the Jedi.

This lot comes from the personal collection of William Plumb. The artwork is rendered, signed, and dated "W. Dybowski 85" in mixed media on board and applied throughout with printed Polish-language credits. The board exhibits visible edge wear throughout with some text flaking off from age. Dimensions: 30" x 22" x 2" (76.25 cm x 56 cm x 5 cm)

Sold without copyright; see notice in the Buyer's Guide.

**Estimate: \$8,000 - 16,000**



**228**  
**The Grail Knight's (Robert Eddison) Sword**  
**Indiana Jones And The Last Crusade (1989)**

The Grail Knight's (Robert Eddison) sword from Steven Spielberg's action-adventure sequel Indiana Jones and the Last Crusade. The ghostly Knight wielded his sword when Indiana Jones (Harrison Ford) arrived in the chamber at the Temple of the Sun, where he had to pass the final test and choose the true Holy Grail.

This broadsword, was gifted by Eddison to actor Tony Church. It is made of forged steel, and the long blade displays a blood groove that runs from the tip to the guard. Finished to resemble gold, the crossguard is decorated with dragon and lion detailing, hatchwork lattice designs adorn the grip, and the weapon displays an ornately decorated pommel. The sword comes housed inside a black leather scabbard with gilded metal detailing. Also included is a Letter of Authenticity confirming the provenance.

The blade exhibits tarnishing, signs of corrosion, nicks, and is slightly loose within the handle. The scabbard exhibits marks, scuffs, and signs of corrosion on the metal. Dimensions: (in scabbard) 39.25" x 8" x 1" (99.5 cm x 20 cm x 2.5 cm)

**Estimate: \$30,000 - 60,000**



**229**  
 Indiana Jones' (Harrison Ford) Screen-Matched Rocket-Propelled Grenade Launcher  
**Indiana Jones And The Kingdom Of The Crystal Skull (2008)**

Indiana Jones' (Harrison Ford) screen-matched rocket-propelled grenade launcher from Steven Spielberg's action-adventure sequel Indiana Jones and the Kingdom of the Crystal Skull. Jones fired an RPG-2 during the jungle chase sequence.

This film-prop, non-functional Type 69 RPG launcher with a brown carrying handle was altered by production to more closely resemble a Soviet-style RPG-2, though the launched rockets themselves were computer-generated. The launcher screen matches based on scratches on the brown body sleeve. It is constructed of metal and resin components painted umber, chrome-color, and charcoal with a green clip-on nylon shoulder strap and serial number "69-I-40-510748-197." Included are two olive and black resin PG-2 anti-tank rockets with metallic finishes and a licensed glossy color still from the film. The RPG launcher and rockets exhibit various signs of use by production, including paint scuffing and chipped resin throughout. Also included is an 8" x 10" production photo showing Jones with his grenade launcher. Dimensions: (launcher) 36" x 7" x 12" (91.5 cm x 18 cm x 30.5 cm)

**Estimate: \$10,000 - 20,000**



**230**  
 Bernie Pollack Collection: Costume Designer Bernie Pollack's Personal Adventurebilt Hat Company Indiana Jones (Harrison Ford) Fedora Replica From Production Run  
**Indiana Jones And The Kingdom Of The Crystal Skull (2008)**

Costume designer Bernie Pollack's personal replica of Indiana Jones' (Harrison Ford) fedora from Steven Spielberg's action-adventure sequel Indiana Jones and the Kingdom of the Crystal Skull. Adventurebilt Hat Company specialized in replicas of the iconic Indiana Jones fedoras from the fourth film. Adventurebilt created this hat as part of its production run and gifted the hat to Pollack for his personal collection.

Pollack was responsible for recreating Jones' iconic costume for the film. In a post-production interview with Spielberg and Ford, Pollack explained the complex design process, which entailed creating a trifold production board featuring stills of Indy wearing his fedora from each of the previous films. Pollack's designs for Indy's hat and wardrobe were then screen-tested before Spielberg approved their final versions. According to the costume designer, Spielberg stated he had lost sleep over replicating the hat, and was pleased when Pollack ultimately produced the perfect fedora.

This hand-made brown beaver felt fedora comes from Pollack's collection. It features a black ribbon, brown leather sweatband labeled "Adventurebilt Hat Company Handmade Fine Fur Felt" in gold, and a white satin liner. Also included are Pollack's trifold production board; five color-printed glossy stills of Ford in his fedora used in costume design meetings during production on the film; a FedEx envelope with a note reading "Hi Bernie! If you need any more, please let me know. All the best, Renee"; and the fedora's original USPS shipping box marked "Attn Bernie - this is your hat." Adventurebilt held this hat back from the run and shipped it to Pollack after the film was released. The liner exhibits minimal staining and the box exhibits denting and scuffing from travel.



**Estimate: \$5,000 - 10,000**

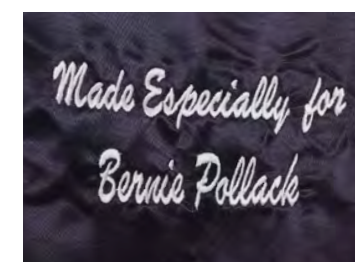
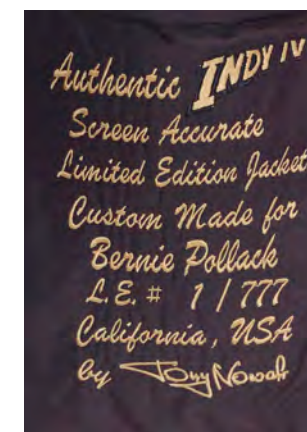

**231**  
 Costume Designer Bernie Pollack's Limited-Edition Tony Nowak Indiana Jones (Harrison Ford) Jacket Replica and Garment Bag  
**Indiana Jones And The Kingdom Of The Crystal Skull (2008)**

Costume designer Bernie Pollack's personal limited-edition replica of Indiana Jones' (Harrison Ford) jacket from Steven Spielberg's action-adventure sequel Indiana Jones and the Kingdom of the Crystal Skull. After creating Jones' leather jacket, Nowak also created a limited run of custom replicas, including one specifically for Pollack.

This brown leather jacket comes from Pollack's collection. Based on the A-2 bomber style, it features two front pockets, buckled sides, an internal "Tony Nowak Original" tag, and "Authentic Indy IV Screen Accurate Limited Edition Jacket Custom Made for Bernie Pollack L.E. # 1/777 California, USA by Tony Nowak" embroidered on the interior lining. The jacket comes in a custom-made brown suede zip-up garment bag featuring a Tony Nowak Original tag and embroidered "Made Especially for Bernie Pollack" along with the film's title logo. The jacket exhibits minimal distressing applied by production to give the jacket a worn appearance.

**Estimate: \$5,000 - 10,000**





**232**  
 Bernie Pollack Collection: Hand-Painted Lois DeArmond Illustration of Bernie Pollack's Iconic Indiana Jones (Harrison Ford) Costume Design  
**Indiana Jones And The Kingdom Of The Crystal Skull (2008)**

A hand-painted illustration of Bernie Pollack's iconic costume design for Indiana Jones (Harrison Ford) made for the production of Steven Spielberg's action-adventure sequel Indiana Jones and the Kingdom of the Crystal Skull. This illustration of Jones wearing his signature fedora and leather jacket while holding his Webley "WG" army model revolver and carrying his signature whip at his side is rendered in watercolors on watercolor bristol board by costume illustrator Lois DeArmond, signed "DeArmond 07" along Jones' leg, and covered with a brown portfolio folder. The board exhibits minor dents along its edges. Dimensions: 15" x 20" x 0.5" (38.25 cm x 51 cm x 1.5 cm)

Sold without copyright; see notice in the Buyer's Guide.

**Estimate: \$5,000 - 10,000**

**233**  
 Bernie Pollack Collection: Hand-Drawn Lois DeArmond Sketch of Bernie Pollack's Iconic Indiana Jones (Harrison Ford) Costume Design  
**Indiana Jones And The Kingdom Of The Crystal Skull (2008)**

A hand-drawn illustration of Bernie Pollack's iconic costume design for Indiana Jones (Harrison Ford) made for the production of Steven Spielberg's action-adventure sequel Indiana Jones and the Kingdom of the Crystal Skull. This sketch of Jones wearing his signature fedora and leather jacket while holding his Webley "WG" army model revolver and carrying his signature whip at his side is rendered in graphite on tracing paper by costume illustrator Lois DeArmond, signed "DeArmond 07" along Jones' leg, and stapled to white paper inside a brown portfolio folder. The sketch exhibits minor wrinkles and stains along the top edge. Dimensions: 14" x 17" (35.75 cm x 43.25 cm)

Sold without copyright; see notice in the Buyer's Guide.

**Estimate: \$2,000 - 4,000**

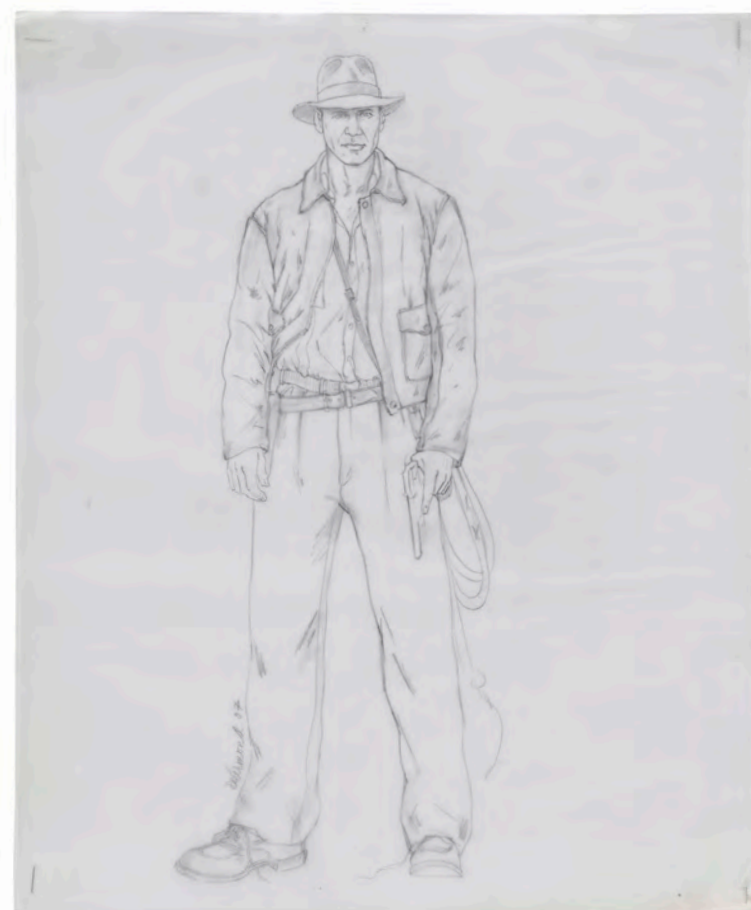

20" (51 cm)



**234**  
 Bernie Pollack Collection: Hand-Painted Lois DeArmond Indiana Jones (Harrison Ford) Train Suit Costume Design Sketch  
**Indiana Jones And The Kingdom Of The Crystal Skull (2008)**

A hand-painted Lois DeArmond Indiana Jones (Harrison Ford) train suit costume design sketch made for the production of Steven Spielberg's action-adventure sequel Indiana Jones and the Kingdom of the Crystal Skull. Jones wore his suit when Mutt Williams (Shia LaBeouf) warned him about a dangerous colleague on the train.

This sketch of Jones in a brown suit, signature fedora, and red tie designed by costume designer Bernie Pollack is hand-painted by costume illustrator Lois DeArmond in watercolors on watercolor bristol board, signed "DeArmond 07" along Jones' leg, and marked "2" in the bottom corner. The board exhibits minor dents along the edges. Dimensions: 15" x 20" (38.25 cm x 51 cm)

Sold without copyright; see notice in the Buyer's Guide.

**Estimate: \$2,000 - 4,000**

**235**  
 Bernie Pollack Collection: Pair of Hand-Painted Lois DeArmond Professor Jones (Harrison Ford) Costume Design Illustrations  
**Indiana Jones And The Kingdom Of The Crystal Skull (2008)**

Two illustrations of Bernie Pollack's iconic costume designs for Professor Jones (Harrison Ford) made for the production of Steven Spielberg's action-adventure Indiana Jones and the Kingdom of the Crystal Skull. Jones wore professorial costumes while teaching archeology at Marshall College.

These two sketches - one of Jones in his three-piece tweed suit with a bowtie and glasses, the other of Jones in a two-piece suit and bowtie - are both rendered by production illustrator Lois DeArmond in watercolor and ink on bristol board and signed "DeArmond 07" along Jones' leg. This lot exhibits minor wear to the corners of the boards. Dimensions: (each) 15" x 20" (38.25 cm x 51 cm)

Sold without copyright; see notice in the Buyer's Guide.

**Estimate: \$3,000 - 6,000**





**236**  
 Donny "The Bear Jew" Donowitz's (Eli Roth) Stunt Baseball Bat With Roped Scalps  
**Inglourious Basterds (2009)**

Donny "The Bear Jew" Donowitz's (Eli Roth) stunt baseball bat with roped scalps from Quentin Tarantino's war-drama *Inglourious Basterds*. Lieutenant Aldo Raine (Brad Pitt) demanded his men to scalp 100 German Nazis each while "The Bear Jew" smashed Nazi soldiers' heads with his baseball bat.

This lot consists of one scalp piece made of latex foam and synthetic hair covered in stage blood and attached to a rope; and a distressed brown foam baseball bat with stage blood stains and markings. This lot exhibits minor cracking in the bat's material. Dimensions: 32.5" x 6" x 4" (82.75 cm x 15.25 cm x 10.25 cm)

**Estimate: \$3,000 - 6,000**



**237**  
 Lestat's (Tom Cruise) Waistcoat and Drinking Glasses  
**Interview With The Vampire: The Vampire Chronicles (1994)**

Lestat's (Tom Cruise) waistcoat and drinking glasses from Neil Jordan's horror film *Interview with the Vampire: The Vampire Chronicles*. In New Orleans, Lestat filled his glass with the blood of a prostitute for the reluctant Louis (Brad Pitt) to drink. Later, Lestat wore his waistcoat as Claudia (Kirsten Dunst) tricked him into drinking the blood of dead twins.

This linen waistcoat features a pale blue front embellished with an embroidered gold-color pattern throughout. A handwritten label sewn to the underarm reads "Lestat 10." The wine glasses each feature a trumpet bowl with a beaded stem. The waistcoat exhibits a blue-color run on the back panel as a result of age and use. Dimensions: (each) 4" x 4" x 7.75" (10 cm x 10 cm x 19.75 cm)

**Estimate: \$5,000 - 10,000**



**238**  
 Five Le Cercle Casino Plaques with £1 Chip  
**James Bond: Dr. No (1962)**

Five gambling plaques and a £1 chip from the Le Cercle casino, the same style seen in Terence Young's Bond film *Dr. No*. MI6 agent 007 (Sean Connery) played baccarat chemin-de-fer against Sylvia Trench (Eunice Gayson) at Ken Adams' set based on the Le Cercle casino.

Le Cercle casino loaned £35,000-worth of its house plaques to EON Productions for the film under the supervision of two security guards. This lot consists of five plaques - one apiece in £5, £10, £50, £100, and £500 denominations - manufactured of glossy plastic composites engraved "Le Cercle" with hot-stamped serial numbers, and a £1 chip. While all originals from Le Cercle casino, it is not possible to know if they were part of the *Dr. No* production.

The £5-pound plaque does not appear in the final cut. The set exhibits some bubbling, bending, and discoloration along the edges. Dimensions: (largest) 4.5" x 3" x 0.5" (11.5 cm x 7.75 cm x 1.5 cm)

**Estimate: \$7,000 - 14,000**



**239**  
 Colibri-Made Wooden Golden Gun  
 Master Model  
**James Bond: The Man With The Golden Gun (1974)**

A wooden master model of the titular golden gun made by men's accessory company Colibri for the production of Guy Hamilton's Bond film *The Man with the Golden Gun*. Francisco Scaramanga (Christopher Lee) used a gun constructed from innocuous, everyday items to assassinate his victims.

Colibri created this wooden model as a master template for the iconic final weapon, which featured heavily in the film's promotional campaign and has since become one of the most recognizable weapons in cinematic history. After production, the model was gifted to the set designer of Scaramanga's kitchen.

This model is constructed from wooden segments carved to match the items used in the film and glued together. Also included is an original envelope hand-labeled "Fragile Handle With Care 007 Golden Gun Mock-Up/Property of 'Colibri'" in red ink on the front. The model exhibits slight separation between the pieces from age and remains fragile, while the envelope exhibits creasing, small tears, and staining. Dimensions: 9.75" x 5.5" x 0.5" (25 cm x 14 cm x 1.5 cm)

**Estimate: \$10,000 - 20,000**







23' (702 cm)

**240**  
**Glastron Carlson Speedboat**  
**Moonraker (1979)**

A Glastron Carlson speedboat from the production of Lewis Gilbert's Bond film Moonraker. In the climactic action sequence, Hugo Drax's (Michael Lonsdale) men chased Bond down the Amazon River in speedboats.

Four Glastron Carlson CV23HT speedboats were acquired for production by EON Productions for the chase sequence and customized with a specialty silver flake gel coat over gray paint applied during the fiberglass molding process. This is believed to be one of only two to survive from production, having been sold at a boat show in 1979 and held in a private collection ever since. However, as the custom upper canopy visible in the film is not included, it remains unknown if one was ever affixed to this boat, and therefore if it was ever filmed.

In addition to its distinctive paint scheme, this operational, gas-powered speedboat features ID number "GCV 10542C," a latching sunshield over the cabin, a "Glastron Carlson" plaque, and a MerCruiser 260 HP stern-driven engine with functional lighting and speaker systems installed. The interior is upholstered with gray leatherette and paneled with varnished wood, and features red velvet and white shag carpeting. A "Moonraker II" decal was affixed to the starboard bow by the current owner. Also included is a Letter of Authenticity from noted James Bond collector and co-founder of The Ian Fleming Foundation, Doug Redenius.

Following production, red pinstriping was added. This pinstriping is tape-based, not paint, and can be removed with heat. Due to age and exposure, the boat exhibits rusting to its internal mechanisms, fading to the exterior and wood finishes, and various liquid streaks and grime, but it retains its iconic silver coloration. As it remains stored and registered in Canada, bidders will need to contact Propstore in advance to arrange shipment and transfer of registration. Dimensions: 276" x 83" x 72" (702 cm x 211 cm x 211 cm)

Contains electronics; see electronics notice in the Buyer's Guide.

Special shipping required; see notice in the Buyer's Guide.

Stored off-site; see off-site storage notice in the Buyer's Guide.

**Estimate: \$30,000 - 60,000**





12' (366 cm)

**241**  
**Russian Special Services Atomic Energy Antiterrorist Unit Land Parahawk**  
**The World Is Not Enough (1999)**

A Russian Special Services Atomic Energy Antiterrorist Unit land parahawk from Michael Apted's Bond film *The World Is Not Enough*. Russian military parahawks ambushed and pursued James Bond (Pierce Brosnan) and Elektra King (Sophie Marceau) across a mountain during their skiing outing.

This high-tech land parahawk is one of only three created by production for the chase sequence. Following production, it was purchased by the Ian Fleming Foundation, from whom it now originates. Constructed from a functional Ski-Doo snowmobile, the vehicle is modified with a black fiberglass shell, matching felt upholstery, a clear acrylic visor, a double-bladed propeller, a metal rotary belt, and four articulated metal skis for controlling its direction. It also features a 2si 460 F45 aircraft engine and a 3.3-gallon gas tank.

The parahawk's interior features a dashboard with controls for the propeller and power, metal footrests, and brake handles. It comes mounted to wooden dollies for transit and has not operated since the end of production. The vehicle exhibits chipping paint along the left side and control panel, as well as rusting to the skis. Following production, it was drained of fluid, rendering it currently nonfunctional, and no warranty is made or implied as to its functionality. Dimensions: 144" x 86" x 86" (366 cm x 218.5 cm x 218.5 cm)

Contains mechanical and electrical components; see notice in the Buyer's Guide.

Special shipping required; see notice in the Buyer's Guide.

**Estimate: \$40,000 - 80,000**

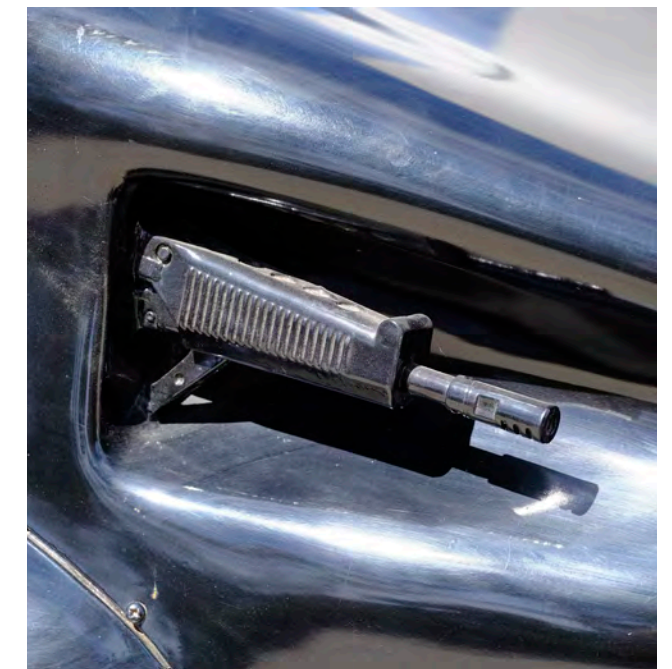

**242**  
Set of Casino L'or Noir Plaques and Chips  
**The World Is Not Enough (1999)**

Casino L'or Noir plaques and chips from Michael Apted's Bond film *The World Is Not Enough*. James Bond (Pierce Brosnan) visited Valentin Zukovsky's (Robbie Coltrane) Casino L'or Noir in search of information on Russian terrorist Renard (Robert Carlyle).

This set consists of one silver \$100,000 and one red \$5,000 plastic casino plaques; a plastic stack of pink \$1,000 chips; and 19 plastic chips in various colors and denominations. Each is printed with Zukovsky's face printed on both sides. The set exhibits bubbling plastic, nicks, and scratching from production use. Dimensions: (plaques) 5.5" x 2.5" (14 cm x 6.5 cm); (chips) 2" x 2" (5" x 5")



**Estimate: \$4,000 - 8,000**

**243**  
\$500,000 Casino Plaque  
**James Bond: Casino Royale (2006)**

A \$500,000 casino plaque from Martin Campbell's Bond film *Casino Royale*. James Bond (Daniel Craig), Le Chiffre (Mads Mikkelsen), and their fellow poker players used betting plaques during the high-stakes game at the Casino Royale in Montenegro.

This plaque is made of red pearlescent plastic with a translucent green center and "Casino Royale \$500,000 Montenegro" printed on both sides in gold-color and black text. It exhibits some scratching from production use. Dimensions: 4.5" x 3.25" x 0.25" (11.5 cm x 8.25 cm x 0.75 cm)



**Estimate: \$4,000 - 8,000**

**244**  
\$1,000,000 Casino Plaque  
**James Bond: Casino Royale (2006)**

A \$1,000,000 casino plaque from Martin Campbell's Bond film *Casino Royale*. James Bond (Daniel Craig), Le Chiffre (Mads Mikkelsen), and their fellow poker players used betting plaques during the high-stakes game at the Casino Royale in Montenegro.

This plaque is made of blue pearlescent plastic with a translucent red and yellow center and "Casino Royale \$1,000,000 Montenegro" printed on both sides in gold-color and black text. It exhibits scratching from production use. Dimensions: 4.5" x 3.25" x 0.25" (11.5 cm x 8.25 cm x 0.75 cm)



**Estimate: \$8,000 - 16,000**



**245**  
Casino Royale Playing Card Deck  
**James Bond: Casino Royale (2006)**

A Casino Royale playing card deck from Martin Campbell's Bond movie *Casino Royale*. James Bond (Daniel Craig), Le Chiffre (Mads Mikkelsen) and their fellow poker competitors played a selection of high-stakes games at the Casino Royale in Montenegro.

This deck of playing cards comes in a white paper box with black and gold-color graphics including the name of the casino. The box is handmarked "game 1" in black ink. The box exhibits some corner denting and small red stains. Dimensions: (in box) 3.75" x 2.75" x 0.75" (9.75 cm x 7 cm x 2 cm)

**Estimate: \$6,000 - 12,000**



**246**  
Set of Floating Dragon Casino Chips  
**Skyfall (2012)**

Three Floating Dragon Casino chips from Sam Mendes' Bond film *Skyfall*. Bond (Daniel Craig) visited the Floating Dragon casino in Macau in search of information about assassin Patrice (Ola Rapace).

These three plastic casino chips feature emerald and gold-color patterns throughout and text reading "FLOATING DRAGON" and "MACAU." The black chip has a HK\$100,000 denomination, the purple chip has a HK\$50,000 denomination, and the burgundy chip has a HK\$10,000 denomination. Both exhibit some bubbling around the edges and scratching throughout from production use. Dimensions (each): 4.5" x 3" x 0.25" (11.25 cm x 7.75 cm x 0.75 cm)

**Estimate: \$4,000 - 8,000**



**247**  
Patrice's (Ola Rapace) Poker Chip  
**Skyfall (2012)**

Patrice's (Ola Rapace) poker chip from Sam Mendes' action-adventure film Skyfall. James Bond (Daniel Craig) turned in Patrice's poker chip to collect a value of four million Euros.

This poker chip is made of red resin with a gold-color painted plastic dragon and trim coated in clear resin for shine. This lot exhibits minor grime from production. Dimensions: 2" x 2" x 0.25" (5 cm x 5 cm x 0.75 cm)

**Estimate: \$5,000 - 10,000**

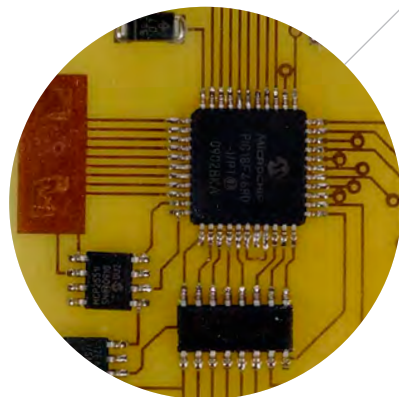

**248**  
Patrice's (Ola Rapace) Hard Drive Lanyard  
**Skyfall (2012)**

Patrice's (Ola Rapace) hard drive lanyard from Sam Mendes' Bond film Skyfall. James Bond (Daniel Craig) hunted Patrice from Turkey to Shanghai to recover a hard drive the assassin stole containing the identities of every undercover NATO operative on Earth.

The lot consists of a plastic and metal hard drive inset with non-functional computer chips embedded in a clear acrylic holster looped with a black cord lanyard. The holster exhibits scratching and the lanyard is fraying at the top from production use. Dimensions: 15" x 3.75" x 0.5" (38.25 cm x 9.25 cm x 1 cm)

**Estimate: \$10,000 - 20,000**



**250**  
SPECTRE Metal Ring  
**James Bond: Spectre (2015)**

A SPECTRE metal ring from Sam Mendes' Bond film Spectre. Blofeld (Christoph Waltz) and other members of SPECTRE wore matching rings featuring the criminal empire's signature octopus emblem.

This custom-made brass metal ring is engraved with the octopus emblem on front, distressed silver-color paint to resemble tarnished metal. It exhibits flaking paint throughout from production wear. Dimensions: 1" x 1" x 1" (2.5 cm x 2.5 cm x 2.5 cm)

**Estimate: \$10,000 - 20,000**



**249**  
Quantum Pin  
**James Bond: Quantum Of Solace (2008)**

A Quantum pin from Marc Forster's Bond film Quantum of Solace. Quantum members working under Dominic Greene (Mathieu Amalric) wore their signature pins throughout the film as they schemed to control fresh water in Bolivia.

This faux silver Q-shaped pin was custom-made in Italy for the production. It exhibits tarnishing from production use. Dimensions: 0.5" x 0.5" x 0.5" (1.5 cm x 1.5 cm x 1.5 cm)

**Estimate: \$4,000 - 8,000**



**251**  
**John Wick's Bloodied Suit**  
**John Wick: Chapter 3-Parabellum (2019)**

John Wick's bloodied suit from Lionsgate's blockbuster hit John Wick: Chapter 3 - Parabellum. Wick wore his suit while running through Manhattan before his fight at the New York Public Library early in the film.

This costume consists of a charcoal-color wool suit jacket and matching trousers (Size 42Wx36R); a white cotton-blend button-up shirt (Size 16 34/35) with red stage blood applied to the lower right abdomen; a black silk tie; a black leather belt with a metal buckle, and a pair of black leather lace-up dress shoes (Size 10M). A tag inside the jacket reads "New Ch 42" with "40" crossed out. The costume exhibits some wear from use, including light staining and scuffing to the shoes.

**Estimate: \$6,000 - 12,000**



**252**  
**Deactivated Blank-Firing Lawgiver Mark II Pistol**  
**Judge Dredd (1995)**

A deactivated Lawgiver Mark II pistol from Danny Cannon's sci-fi adventure Judge Dredd. Lawgivers, the signature weapons of Judge Dredd (Sylvester Stallone) and the Street Judges who patrolled Mega-City One, only operated when their rightful owners wielded them.

Created for scenes requiring live-fire, this futuristic pistol features a detailed, ribbed resin clamshell cast around a Beretta 92FS pistol and painted black and silver-color with rubber pistol grips, a machined aluminum barrel extension, and a matching base on the magazine. It features the Hall of Justice crest on the side, red and blue acrylic inserts in place of lights, and a vented sight post.

Also included are a rubber prototype grip, an additional Double Whammy lens barrel, and a Certificate of Deactivation from London Proof House noting the weapon's sympathetic deactivation following production. The pistol exhibits breakage to its sight, shrunken rubber, and paint scuffing throughout from production use and age. Dimensions: 12" x 7" x 2" (30.5 cm x 18 cm x 5 cm)

Firearm deactivated; see firearm deactivation notice in the Buyer's Guide.

**Estimate: \$10,000 - 20,000**

**253**  
**Light-Up Judge Hunter Rifle**  
**Judge Dredd (1995)**

A light-up Judge Hunter rifle from Danny Cannon's comic book adaptation Judge Dredd. Judge Hunters wielded their futuristic standard-issue rifles throughout the film.

This rifle consists of a fiberglass body painted black with red plastic vents, a urethane sight, painted wood and particle board details, and metal attachments along the barrel and frame. It also features a black leather strap with metal hardware. The back of the rifle's scope has undergone sympathetic repair. This lot exhibits notable adhesive residue and fragile components. Dimensions: 45" x 16" x 5" (114.5 cm x 40.75 cm x 12.75 cm)

Contains electronics; see electronics notice in the Buyer's Guide.

Ownership may be restricted in some countries; see replica firearm notice in Buyer's Guide.

**Estimate: \$5,000 - 10,000**





Replica Game Pieces

**254**  
**Screen-Matched Jumanji Game Board**  
**Jumanji (1995)**

A screen-matched Jumanji game board from Joe Johnston's family adventure film Jumanji. Shoemaking heir Alan Parrish (Robin Williams) was sucked into the magical survivalist board game Jumanji and later freed by Peter Shepherd (Bradley Pierce), only to be forced to continue playing his game from 26 years before.

Based on Chris Van Allsburg's children's picture book, Jumanji overtook Pixar's Toy Story's Number 1 box office slot and became a critical success, spawning numerous sequels, an animated series, and an actual board game published by Milton Bradley.

As the components were interchanged from shot to shot, various parts of this production-made game board screen match to scenes in the film, including when young Shepherd was turned into a monkey as punishment for trying to cheat the game, when the rules fade in while Alan is stuck in the floor, and when Alan ultimately wins the game in the climactic scene.

This jungle-themed rectangular game board is constructed of resin, affixed with a green glass orb, and set into the center of a dense rubber and metal case painted to look wooden and affixed with carved wooden animal details. Four replica resin pieces in the shapes of a gray elephant, a green monkey, a white rhinoceros, and a black crocodile are also included in the foam-padded side slots where the game's instructions are printed in red and black ink, and the token covers were added for display purposes.

This board has come loose from the case and exhibits other signs of use, including exposed rubber throughout and damage to the top of the rhinoceros, but it remains in good overall condition. Dimensions (board): 16.5" x 25.25" x 2" (42 cm x 64.25 cm x 5 cm); (pieces, each) 1" x 1" x 1.5" (2.5 cm x 2.5 cm x 4 cm)

**Estimate: \$75,000 - 150,000**



**255**  
Set of Four Game Piece Prototypes  
**Jumanji (1995)**

A set of four game piece prototypes from the production of Joe Johnston's family adventure film Jumanji. Shoemaking heir Alan Parrish (Robin Williams) was sucked into the magical survivalist board game Jumanji and later freed by Peter Shepherd (Bradley Pierce), only to be forced to continue playing his game from 26 years before.

Differing in colour and texture from the final game pieces seen in the film, this lot consists of four resin game piece prototypes in the shapes of a dark green elephant, a light green monkey, a dark gray rhinoceros, and a light brown crocodile. They are in excellent overall condition with minimal wear from production and handling. Dimensions (each): 2.75" x 1" x 1.25" (7 cm x 2.75 cm x 3.25 cm)

**Estimate: \$4,000 - 8,000**

**256**  
Van Pelt's (Jonathan Hyde) Light-Up  
Replica USAS-12 Shotgun  
**Jumanji (1995)**

Van Pelt's (Jonathan Hyde) light-up replica USAS-12 shotgun from Joe Johnston's comedy-adventure film Jumanji. Pelt wielded his USAS-12 shotgun as he hunted down Alan Parish (Robin Williams) through town.

Created by Prop Master Dan Sissons, this replica USAS-12 shotgun is made of black painted fiberglass featuring a metal practical light-up scope that functions when the scope cap is removed and twisted, and a metal barrel. The shotgun was created to use in the various street scenes. This shotgun exhibits various points of scuffs and chipping paint from production use. Dimensions: 41.5" x 7.5" x 15" (105.5 cm x 19 cm x 38.25 cm)

Contains electronics; see electronics notice in the Buyer's Guide.

Ownership may be restricted in some countries; see replica firearm notice in Buyer's Guide.

**Estimate: \$6,000 - 12,000**



**257**  
Spencer's (as played by Dwayne Johnson) Dr. Smolder  
Bravestone In-Game Costume and Grappling Hook  
**Jumanji: Welcome To The Jungle (2017)**

Spencer's (as played by Dwayne Johnson) Dr. Smolder Bravestone in-game costume and grappling hook from Jake Kasdan's adventure-comedy film Jumanji: Welcome to the Jungle. Spencer wore his costume as he played Dr. Smolder Bravestone in the Jumanji video game who wielded a grappling hook.

This lot consists of a beige button-down short-sleeve shirt labeled "DJ Aug 2016"; light green cotton-blend cargo pants (size 38) marked "DJ"; a dark brown leather belt marked "DJ"; black leather fingerless gloves; dark brown lace-up boots (size 15) marked "DJ #2"; and a silver-color painted dense rubber grappling hook with a rope attached. This lot exhibits intentional distressing on the costume and a broken arm on the grappling hook. Dimensions: 20" x 20" x 20" (51 cm x 51 cm x 51 cm)

**Estimate: \$5,000 - 10,000**



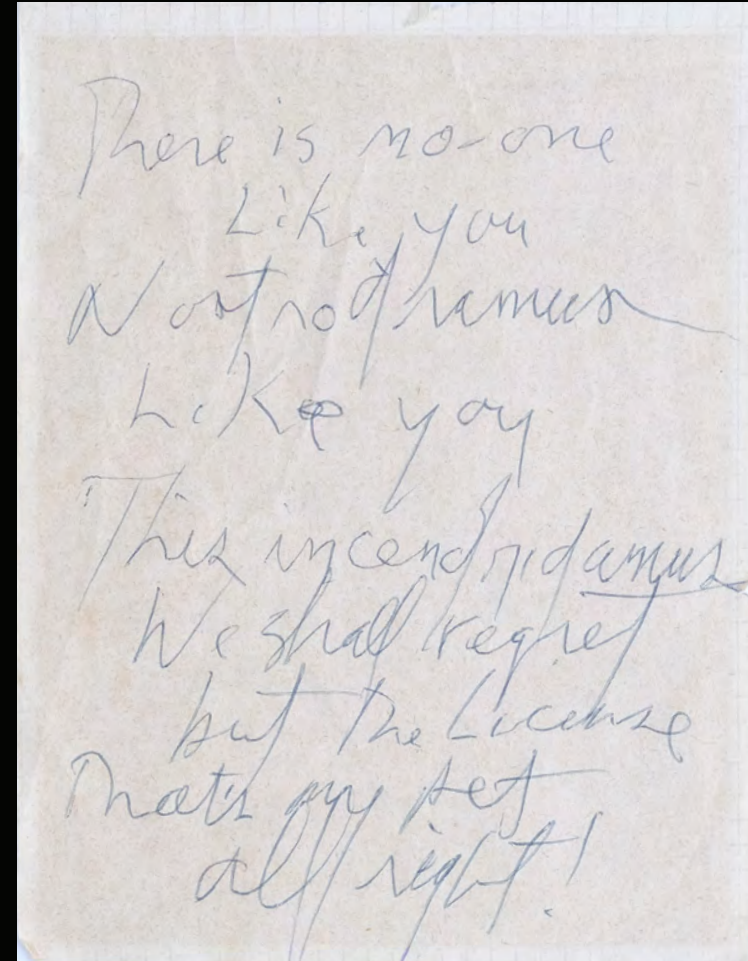

Handwritten lyrics by Jim Morrison

**258**  
Set of Handwritten Poems, Lyrics, and Notes  
**Jim Morrison**

Poems, lyrics, and notes by The Doors' lead vocalist Jim Morrison. Morrison dictated various poems and phrases to a fellow passenger, Ken Lambert, he met on a flight from London to Los Angeles on August 28, 1970. Morrison also hand-wrote a sheet of lyrics, played tic-tac-toe with Lambert, and initialed five of Lambert's handwritten dictation pages - including three poems, a drawing, and the game, "JM."

This set consists of 11 pages rendered in pen, one printed page with basic information about Morrison and Lambert's encounter, and ten printed pages of Lambert recounting the experience in detail. They exhibit minor fraying along their edges with one page intentionally torn at the bottom and discoloration, including a two-tone from being previously matted. Dimensions: (each) 12" x 17.5" x (30.5 cm x 44.5 cm)

Sold without copyright; see notice in the Buyer's Guide.

**Estimate: \$15,000 - 30,000**

Jim Morrison  
& Ken Lambert  
London to Los Angeles  
August 28, 1970  
12 Hours of Original  
Rock 'n' Roll  
at 30,000 feet  
(and the jet was  
even higher...)

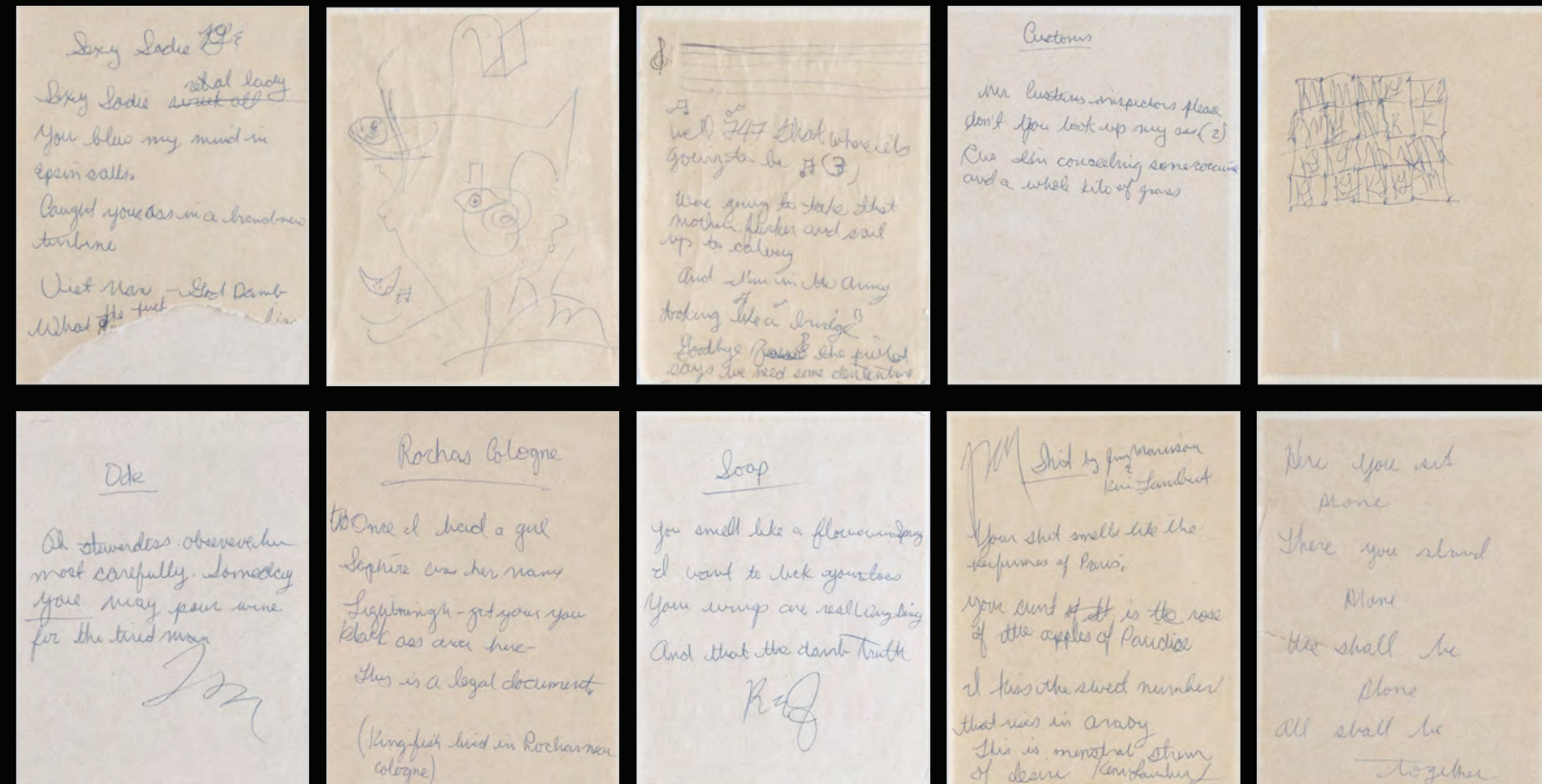

Handwritten pages by Ken Lambert, some initialed by Morrison indicating his co-authorship of the poems

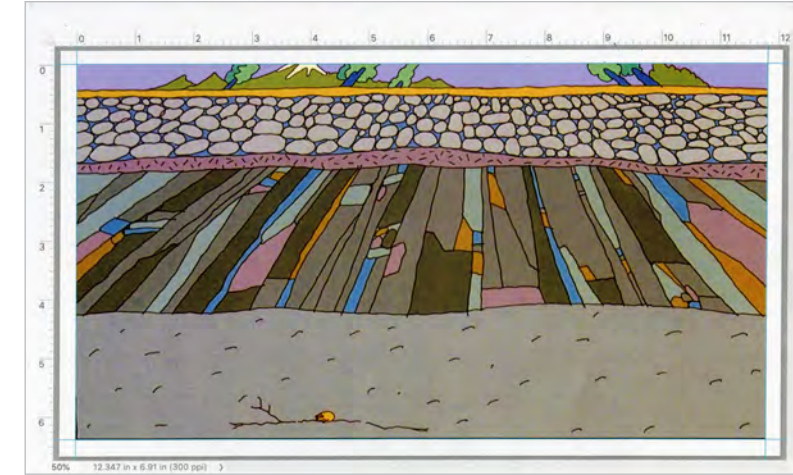

**259**  
Amber Digging Animation Cels, Background Print, and Hand-Illustrated Sketches  
**Jurassic Park (1993)**

Amber digging animation cels, background print, and hand-illustrated sketches from the production of Steven Spielberg's sci-fi adventure Jurassic Park. An animation was created for the educational film that Mr. John Hammond (Richard Attenborough) presented to Dr. Alan Grant (Sam Neill) and his team that explained how dinosaurs' DNA was extracted from amber.

This lot consists of one acetate cel hand-painted with a dug tunnel marked "3.A GR. 3"; one cel of excavationists digging in the tunnel marked "3.A 61"; one hand-drawn dug tunnel marked "GR 3" with handwritten notes; one hand-drawn excavationists illustration marked "SC3A 12FC 61"; one hand-drawn line marked "SC3A GR-1"; and one scaled print image of the Earth's crust with an amber egg at the bottom. This lot exhibits minor wrinkles to the background's corners. Dimensions: (largest) 17" x 11" (43.25 cm x 28 cm); (smallest) 12.5" x 10.5" (31.75 cm x 26.75 cm)

Sold without copyright; see notice in the Buyer's Guide.

**Estimate: \$4,000 - 8,000**

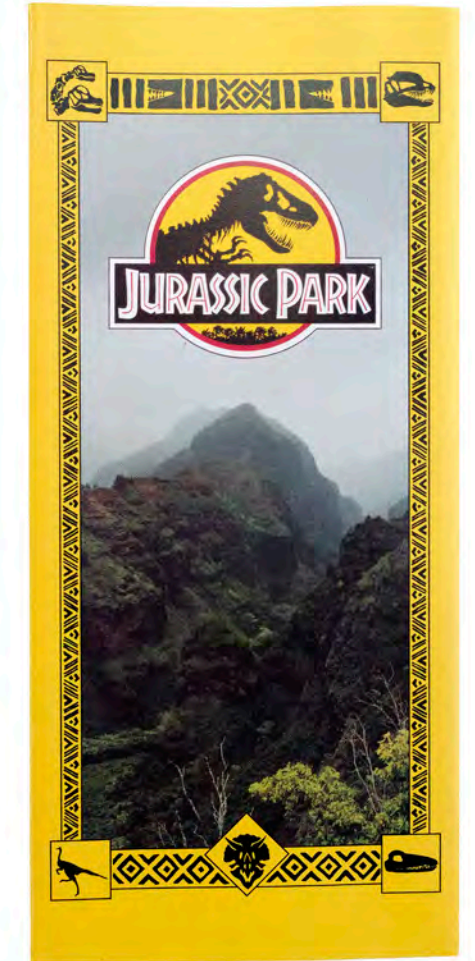

**260**  
Park Visitor Brochure  
**Jurassic Park (1993)**

A park visitor brochure from Steven Spielberg's Academy Award®-winning sci-fi action-adventure Jurassic Park. The park's brochures appeared at various locations, including the Visitor Center and within the Ford Explorer tour vehicles.

This double-sided, glossy paper brochure features a printed map of Jurassic Park on one side pinpointing sites on the island, including the Visitor Center, helipad, dinosaur enclosures, and fences. Its reverse features a printed drawing of the park gates with general information, a section in Japanese, a camera film advertisement, and a mountain terrain photograph that forms the cover. The brochure exhibits creasing and edge wear from folding. Dimensions: (folded) 8.25" x 4" (21 cm x 9.5 cm)

**Estimate: \$3,000 - 6,000**



# THE SAM NEILL COLLECTION

Actor Nigel "Sam" Neill was born on September 14, 1947 in Omagh, Northern Ireland. After moving to New Zealand in 1954, Neill studied English literature, and adopted the name "Sam" while fighting a childhood stutter. In 1971, he appeared in his first film as Sam Neill, *The City of No*, before receiving a starring role as the beleaguered Smith in Roger Donaldson's political thriller *Sleeping Dogs*. Often considered among the best New Zealand films of all time, it also landed Neill international notice as a potential new leading man.

After a break-out year in 1981, in which he appeared in both Andrzej Zulawski's horror classic *Possession* and as the grown Damien in Graham Baker's *Omen III: Final Conflict*, Neill established himself as a performer of unusual range in such landmark Hollywood films as *The Hunt for Red October*, *The Jungle Book*, and *Event Horizon*. But it was his role as Dr. Alan Grant in Steven Spielberg's epochal *Jurassic Park* which cemented his position amongst the most successful and best-regarded actors in history. Neill again portrayed the ornery but heroic Dr. Grant in two more films in the beloved mega-franchise, earning billions of dollars in box-office sales and the hearts of viewers around the world.

In celebration of his one-of-a-kind 50-plus-year career, Propstore is proud to present select *Jurassic Park* and *Jurassic World* lots from this master actor's personal archive to the public for the first time. Profits from the sales of lots in the Sam Neill Collection will benefit UNICEF's Children's Charity. Having survived stage 3 T-cell lymphoma in 2022, Neill continues to star in films and series while running his Alexandra winery, Two Paddocks.



Photo 12 / Alamy Stock Photo

## 261 Sam Neill Collection: Dr. Alan Grant's (Sam Neill) Boots *Jurassic Park* (1993)

Dr. Alan Grant's (Sam Neill) boots from Steven Spielberg's Academy Award®-winning sci-fi action-adventure *Jurassic Park*. Grant wore his boots throughout his fateful trip to Isla Nublar, at first touring the facility and later escaping from its carnivorous inhabitants.

This lot comes from Sam Neill's personal collection and will benefit UNICEF's Children's Charity. It consists of distressed tan leather work boots with black leather boot collars, metal lace eyelets, rubber soles, and yellow and brown cotton-blend laces. In addition to the production-applied distressing, the boots exhibit scuffing, staining, and fading from use and age.

**Estimate: \$6,000 -12,000**

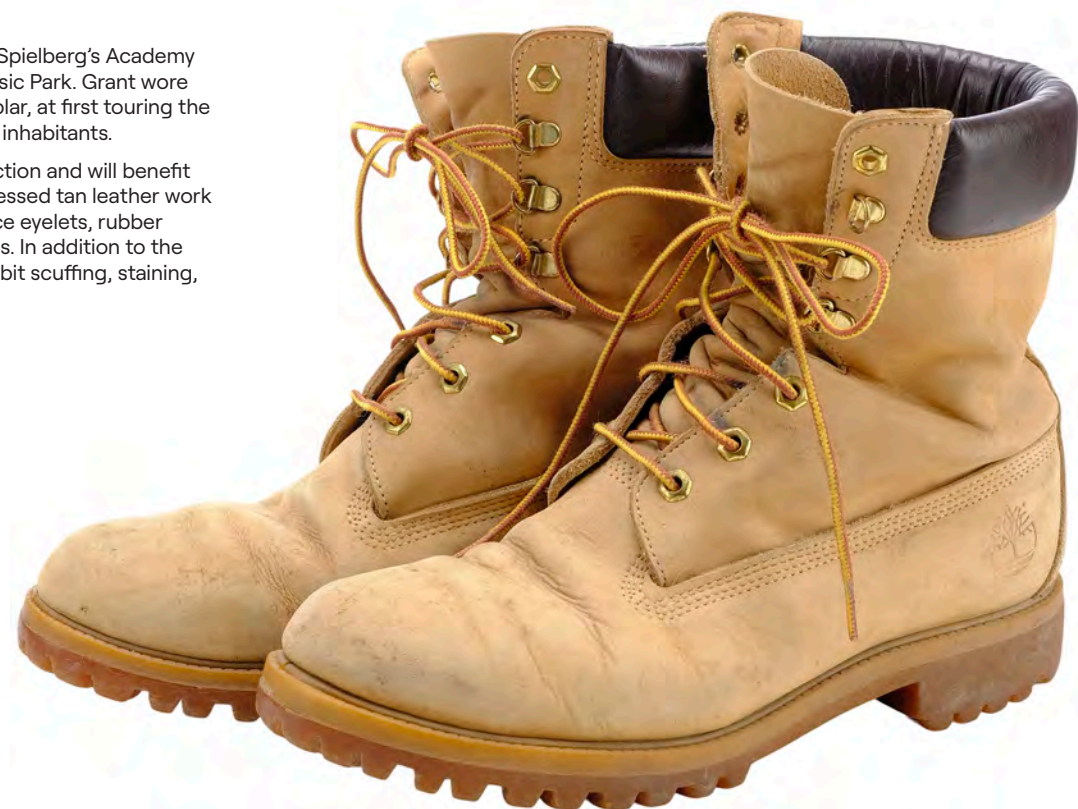

## 262 Sam Neill Collection: Dr. Alan Grant's (Sam Neill) Hat *Jurassic World Dominion* (2022)

Dr. Alan Grant's (Sam Neill) hat from Colin Trevorrow's sci-fi action-adventure sequel *Jurassic World Dominion*. Grant wore his hat throughout the film, from his dig site in Utah to the Biosyn research facility and sanctuary in the Dolomite mountains of Italy.

This lot comes from Sam Neill's personal collection and will benefit UNICEF's Children's Charity. This brown felt fedora features a dark brown leather hatband. It exhibits staining from use along the brim and inner band.

**Estimate: \$10,000 - 20,000**



Interior of Hat



Moviestore Collection Ltd / Alamy Stock Photo



**263**  
**Sam Neill Collection: Dr. Alan Grant's (Sam Neill) Jacket**  
**Jurassic World Dominion (2022)**

Dr. Alan Grant's (Sam Neill) jacket from Colin Trevorrow's sci-fi action-adventure sequel Jurassic World Dominion. Grant wore his jacket while he and Dr. Ellie Sattler (Laura Dern) visited the U.S. Wildlife Relocation Facility and at Biosyn's research facility and sanctuary, where they investigated the giant locusts wiping out crops.

This lot comes from Sam Neill's personal collection and will benefit UNICEF's Children's Charity. This brown cotton jacket features a button-up closure, four front pockets, and a dark brown corduroy collar. Also included is a production tag reading "Alan Grant Change 2 Hero - Reduced from Large to Medium." The jacket exhibits staining from use, including around the collar.

**Estimate: \$10,000 - 20,000**



**264**  
**Sam Neill Collection: Dr. Alan Grant's (Sam Neill) Shirt**  
**Jurassic World Dominion (2022)**

Dr. Alan Grant's (Sam Neill) shirt from Colin Trevorrow's sci-fi action-adventure sequel Jurassic World Dominion. Grant wore his shirt while he and Dr. Ellie Sattler (Laura Dern) visited the U.S. Wildlife Relocation Facility and at Biosyn's research facility and sanctuary, where they investigated the giant locusts wiping out crops.

This lot comes from Sam Neill's personal collection and will benefit UNICEF's Children's Charity. This long-sleeve, denim, button-up shirt features one external chest pocket, one internal chest pocket, blue elastic loops on each side, and a Saturdays New York City sewn-in tag. It exhibits staining throughout from production use.

**Estimate: \$4,000 - 8,000**



**265**  
**Sam Neill Collection: Dr. Alan Grant's (Sam Neill)**  
**Handkerchief**  
**Jurassic World Dominion (2022)**

Dr. Alan Grant's (Sam Neill) handkerchief from Colin Trevorrow's sci-fi action-adventure sequel Jurassic World Dominion. Grant carried his handkerchief while he worked at a paleontological dig site in Utah where he was reunited with Dr. Ellie Sattler (Laura Dern).

This lot comes from Sam Neill's personal collection and will benefit UNICEF's Children's Charity. This red handkerchief is made of cotton and features elaborate tan-color patterns printed throughout. It exhibits minimal wear, including light edge wear. Dimensions: 20" x 19" x 0.25" (51 cm x 48.5 cm x 0.75 cm)

**Estimate: \$2,000 - 4,000**

**266**  
**Jurassic Park Walkie Talkie Set and**  
**Dock**  
**Jurassic World (2015)**

A Jurassic Park walkie talkie set and dock from Colin Trevorrow's adventure-sci-fi film Jurassic World. Jurassic Park radios were seen behind Owen Grady (Chris Pratt) as he and Claire Dearing (Bryce Dallas Howard) searched the old park ruins for her nephews.

Based on the radios seen in Steven Spielberg's 1993 classic Jurassic Park, these plastic radios are painted white with dirt and some dried stage blood. The charging dock for these radios features a Jurassic Park logo. These radios exhibit signs of intentional wear from production and use. Dimensions: 17" x 11" x 16" (43.25 cm x 28 cm x 40.75 cm)

**Estimate: \$3,000 - 6,000**



**267**  
**Dinosaur Egg with QR Code**  
**Jurassic World: Fallen Kingdom (2018)**

A dinosaur egg with a QR code from J.A. Bayona's sci-fi-adventure film Jurassic World: Fallen Kingdom. Scientists placed QR codes as they created the dinosaur eggs in the lab to keep track of each gene splicing conducted.

This lot consists of a textured beige-painted and black speckled resin egg with a gray vinyl QR code and a clear acrylic square bracket display stand. This lot exhibits minor chipping paint. Dimensions: 4" x 4" x 6" (10.25 cm x 10.25 cm x 15.25 cm)

**Estimate: \$3,000 - 6,000**

**268**  
**Diorama Room Six-foot Protoceratops**  
**Skeleton Display**  
**Jurassic World: Fallen Kingdom (2018)**

A diorama room six-foot protoceratops skeleton display from J.A. Bayona's action-adventure sequel Jurassic World: Fallen Kingdom. Maisie Lockwood (Isabella Sermon) hid behind the protoceratops skeleton in the Lockwood Library as Eli Mills (Rafe Spall) took Mr. Eversoll (Toby Jones) into the nearby lift, which led to his underground research facility.

Prioritizing authenticity to achieve Bayona's vision for "bringing dinosaurs into our world," set decorators sought out and rented scientifically accurate cast fossil skeletons for the Lockwood Mansion scenes. This custom-made skeleton was cast in durable plastic resin materials and mounted with a reinforced stainless steel armature in a rigid, scientifically accurate walking pose. The skeleton model breaks down into multiple components for transportation, and a steel base is included for display. This skeleton exhibits discoloration. Dimensions: (crated) 90" x 48" x 48" (228.5 cm x 122 cm x 122 cm)

Special shipping required; see notice in the Buyer's Guide.

**Estimate: \$10,000 - 20,000**



7' 5" (122 cm)



**269**  
 Daniel LaRusso's (Ralph Macchio) Screen-Matched  
 Miyagi-Do Kimono  
**The Karate Kid Part II (1986)**

Daniel LaRusso's screen-matched (Ralph Macchio) Miyagi-Do kimono from John G. Avildsen's sports sequel *The Karate Kid Part II*. This kimono screen-matches to when LaRusso and Mr. Miyagi (Pat Morita) were seated together for Kumiko's (Tamlyn Tomita) fan dance.

Following the global success of Avildsen's *The Karate Kid*, a sequel was immediately produced to deepen the mythology around LaRusso's iconic, quotable mentor, Mr. Miyagi. *The Karate Kid II* was among 1986's most profitable films, securing an extensive life for the beloved franchise and popularizing Japanese-inspired aesthetics in a generation of American viewers.

This red polyester-blend kimono with black motifs and a matching attached belt is embroidered on the front and back with gold-color Miyagi-Do patches depicting a sun setting behind a tree. The kimono exhibits some fraying and minor staining from production wear and age.

**Estimate: \$100,000 - 200,000**



United Archives GmbH / Alamy Stock Photo





**270**  
David Jordan's IVA Space Suit  $\Delta$   
**Life (2017)**

David Jordan's IVA space suit from Daniel Espinosa's sci-fi horror *Life*. Jordan wore his suit as he and Miranda North entered the two remaining escape pods, fleeing the doomed International Space Station.

The costume consists of a helmet, a brown leather skullcap with beige paneling, a beige cotton jumpsuit, beige boots, and a backpack with plastic tubing for internal air flow system (untested). The plastic tubing and rig features "J2" and "JORDAN 2" hand-marked in black marker on attached masking tape. A hand-marked "FAN BAR" bag includes seven rubber and plastic components.

The helmet features metal banding, strips of boning at the back with visible stitching, a transparent plastic visor, and a black throat microphone positioned near the skullcap's chinstrap. The suit features a dual front-zip closure with embroidered hook-and-loop-adhered mission patches. Various components are adhered to the front, including metal buckled silver-color nylon straps, fabric-wrapped nylon mesh tubing with metal quick-attach waist connectors, blue strips on the arms, and a plastic gauge on the left sleeve. A gray utility strap runs across the chest, with "D. Jordan" namestrip with blue English and Cyrillic text. The backpack features mesh panels, two straps and a zip. Included are three pairs of unworn production-acquired beige cashmere gloves with original manufacturer's hang tags; one pair of worn like aforesaid type; and three pairs of white cotton gloves. The lot exhibits minimal staining, metal scratches, and scuff marks.

Contains electronics; see electronics notice in the Buyer's Guide.

**Estimate: \$10,000 - 20,000**



**271**  
Little Nicky's (Adam Sandler) Flask  
**Little Nicky (2000)**

Little Nicky's (Adam Sandler) flask from Steven Brill's supernatural comedy *Little Nicky*. Nicky tried to trap his brothers inside his signature flask to save his father, Satan (Harvey Keitel).

This lot consists of one custom-made metal flask. This silver-color flask is embellished throughout with molds of tiny skulls, bone-like spikes and hellish flames with a scarab emblem on the front. A removable, two-faced horned skull cap is affixed at the top of a cork stopper, and a skull-shaped chain dangling from the right side keeps it attached to the flask. Also included is a letter of authenticity from New Line Cinema. This lot exhibits mild tarnishing, discoloration, and cork fragility. Dimensions: 4" x 6" x 2" (10.25 cm x 15.25 cm x 5 cm)

**Estimate: \$10,000 - 20,000**

**272**  
Frodo's (Elijah Wood) Hobbit Ears  
**The Lord Of The Rings: The Return Of The King (2003)**

Frodo's (Elijah Wood) Hobbit ears from Peter Jackson's fantasy sequel *The Lord of the Rings: The Return of the King*. Frodo, a halfling with pointed ears from the Shire, journeyed to Mordor to destroy the One Ring.

All of the Hobbits' ears were custom-made by Weta Workshop to securely fit on each performer. These ornately detailed latex appendages, one for each side, are hand-painted pink and peach to resemble skin with gaps in each to allow Wood to hear on set. These ears exhibit some brittleness from age and stains on each from production use.

**Estimate: \$4,000 - 8,000**





**273**  
 The Witch-king's (Brent McIntyre) Dagger  
**The Lord Of The Rings: The Fellowship Of The Ring (2001)**

The Witch-king's (Brent McIntyre) dagger from Peter Jackson's fantasy epic The Lord of the Rings: The Return of the King. The Witch-king used his dagger, otherwise known as the Morgul-knife, to stab Frodo (Elijah Wood) when the Nazgûl attacked him and his three companions.

This sword was produced by Weta Workshop and, during a visit to the set in 2002, was gifted to executives at Sideshow Toys, who were licensed to distribute collectables from the films. It features a jagged aluminum blade and a silver-color, metal-plated urethane cross-guard, a black resin grip, and a spiked pommel. The dagger has been intentionally distressed to appear rusted and menacing. An engraving along the blade features the Weta logo and text that reads "Witch King Dagger, Sideshow Toys/12 June 02/0002W." Dimensions: 26.5" x 6.75" x 1.5" (67.5 cm x 17 cm x 4 cm)

**Estimate: \$25,000 - 50,000**





**274**  
 Weta Workshop Master Swordsmith Collection Replica  
 of the Witch-King of Angmar Sword and Scabbard  
**The Lord Of The Rings Trilogy (2001-2003)**

A Weta Workshop master swordsmith collection replica of the Witch-king of Angmar's sword and scabbard from Peter Jackson's The Lord of the Rings trilogy. The Witch-king of Angmar (multiple actors) wielded a flaming, pitted broadsword.

Designed by Warren Mahy and created by master swordsmith Peter Lyon, this lot consists of a sword, scabbard, and a wooden lidded box. The tempered spring steel bladed sword has a curved crossguard and spiked pommel on a wood-worked, leather-covered grip. Its black leather scabbard has a pointed steel tip, matching leather and steel straps, and a carved wooden case affixed with Weta and New Line Productions plaques. Included is a COA noting that this is number 8 of 15 made and care instructions. This lot exhibits mild pitting and tarnishing. Dimensions: 59.5" x 9.75" x 4" (151.25 cm x 25 cm x 10.25 cm)

**Estimate: \$12,000 - 24,000**

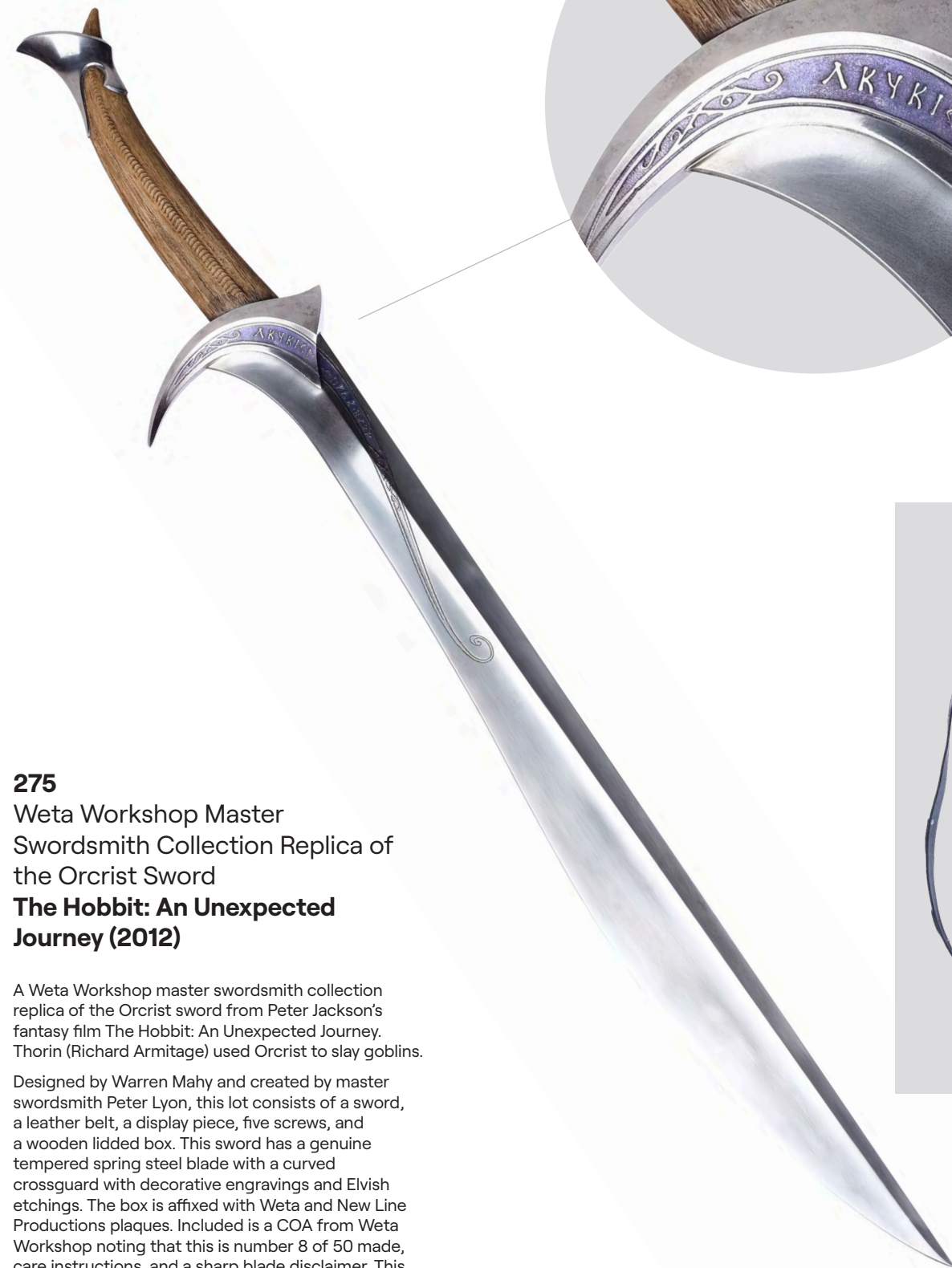

**275**  
 Weta Workshop Master  
 Swordsmith Collection Replica of  
 the Orcrest Sword  
**The Hobbit: An Unexpected  
 Journey (2012)**

A Weta Workshop master swordsmith collection replica of the Orcrest sword from Peter Jackson's fantasy film The Hobbit: An Unexpected Journey. Thorin (Richard Armitage) used Orcrest to slay goblins.

Designed by Warren Mahy and created by master swordsmith Peter Lyon, this lot consists of a sword, a leather belt, a display piece, five screws, and a wooden lidded box. This sword has a genuine tempered spring steel blade with a curved crossguard with decorative engravings and Elvish etchings. The box is affixed with Weta and New Line Productions plaques. Included is a COA from Weta Workshop noting that this is number 8 of 50 made, care instructions, and a sharp blade disclaimer. This lot exhibits scratches in the wood finish and minor splintering. Dimensions: 49.5" x 8" x 2" (125.75 cm x 20.5 cm x 5 cm)

**Estimate: \$12,000 - 24,000**





**276**  
 Max Rockatansky's (Tom Hardy) Muzzle  
**Mad Max: Fury Road (2015)**

Max Rockatansky's (Tom Hardy) muzzle from George Miller's post-apocalyptic action film Mad Max: Fury Road. Max was captured by the army of Immortan Joe (Hugh Keays-Byrne), fitted with a muzzle, and forced to give blood to Joe's soldiers, known as War Boys.

This lot consists of a urethane rubber, foam, and leather muzzle mounted to a polyfoam replica molded from a production-made head cast of Tom Hardy. It includes a trident-like mouthpiece and straps that fit around the back of the head and neck. Painted a gun-metal gray with flecks of silver-color highlighter, it features external molded rubber screws and bolts and two interior metal pins to keep the muzzle together. Along the interior of the jaw strap is a hand-marked "J" in white ink that has faded. Production intentionally distressed this muzzle with rust-like details. This lot exhibits pitting, cracking, and mild tearing of the appliance with notable adhesive and paint marks. Dimensions: 12" x 6" x 7.5" (30.5 cm x 15.25 cm x 19 cm)

**Estimate: \$8,000 - 16,000**



**277**  
 Max Rockatansky's (Tom Hardy) Shotgun  
**Mad Max: Fury Road (2015)**

Max Rockatansky's (Tom Hardy) shotgun from George Miller's post-apocalyptic action film Mad Max: Fury Road. Max used his shotgun to hold up the Wives and Furiosa (Charlize Theron), who along with Nux (Nicholas Hoult) used the shotgun in later sequences.

Acquired from a crew member during production in Africa, this static metal double-barreled shotgun features dual triggers, a resin wood hand grip and forearm, and plating on both sides as well as on the back of the breech with decorative engravings. The gun is intentionally distressed by production to appear aged and dirtied. It additionally exhibits scratches and pitting in the resin from production use. Dimensions: 19" x 3.5" x 1.75" (48.5 cm x 9 cm x 4.25 cm)

Ownership may be restricted in some countries; see replica firearm notice in Buyer's Guide.

**Estimate: \$3,500 - 7,000**



**278**  
 Furiosa's (Charlize Theron) SKS Rifle  
**Mad Max: Fury Road (2015)**

Furiosa's (Charlize Theron) rifle from George Miller's post-apocalyptic action film Mad Max: Fury Road. Furiosa used her rifle against the Rock Riders biker gang.

This lot consists of one static rubber and plastic rifle modeled after the Chinese type 56 SKS rifle. It features a modified blocky grip extension made of hard foam on the stock's underside, as well as two plastic Weaver rails for scope mounting. The stock was carved and painted to resemble dried, cracked wood. Production intentionally distressed this rifle to give it an aged and dirty appearance. This weapon exhibits some splitting of the rubber on the trigger and notable cracks. Dimensions: 40" x 5" x 2" (101.75 cm x 12.75 cm x 5 cm)

Ownership may be restricted in some countries; see replica firearm notice in Buyer's Guide.

**Estimate: \$5,000 - 10,000**



**279**  
 Jessica Jones' Finale Costume with Stunt Jacket  
**Marvel's Jessica Jones (2015-2019)**

Jessica Jones' finale costume with a stunt jacket from Neasa Hardiman's crime drama series Marvel's Jessica Jones. In the Season 3 episode "A.K.A. Everything," Jones wore her costume when she decided to stay in New York as a private investigator.

This lot consists of a pair of black leather CAT zipper boots (W 9 1/2) labeled "1B 1 JJ Hero"; a black cotton hoodie (size M); a black tank top; blue cotton denim jeans (size 29 mid-rise slim crop fit) marked "[Heart]" and "#1 Hero"; a black leather jacket marked "Stunt" and "JJ Stunt Dirty" (size 32); and one red production tag. Also included is a Certificate of Authenticity co-signed by Joe Quesada, EVP, Creative Director, Marvel Entertainment. This lot exhibits intentional distressing on the jeans and a tear in the jacket's lining.

**Estimate: \$8,000 - 16,000**



**280**  
 Peter Quill's (Chris Pratt) Light-Up "Star-Lord" Helmet  
**Guardians Of The Galaxy (2014)**

Peter Quill's (Chris Pratt) light-up "Star-Lord" helmet from James Gunn's sci-fi comedy Guardians of the Galaxy. Star-Lord wore his signature partial helmet throughout the film as he fought alongside the Guardians of the Galaxy.

Guardians of the Galaxy helped set the stage for Phase Two of the MCU, earning numerous Academy Award®, Grammy®, and Billboard® nominations for its groundbreaking effects and 70s and 80s-heavy soundtrack. Quill's Star-Lord helmet is among the most recognizable accessories from this intergalactic success, which was the third-highest-grossing film of 2014.

This foam and suede-padded, two-piece cast urethane resin helmet is hand-painted with a variety of different finishes to resemble metal, inset with two-toned red (on the exterior) and blue (on the interior) lenses, and applied with grid-patterned acrylic sheets on the front as well as small segments of metal tubing, screws, and mesh throughout. Black neoprene covers the neck and a black elastic strap is affixed across the top. The pieces are secured together with powerful magnets concealed on the interior.

Labeled with stickers marked "HERO 3" and "3," the helmet's interior also conceals a 9V battery-powered switch which illuminates LEDs inside the lenses and a red LED light on the right side when flicked. It is intentionally lightly distressed to appear well-worn with scuffs and scratches throughout, and a tongue piece designed to be concealed when the helmet's pieces are connected has broken off to the front on one side.

Contains electronics; see electronics notice in the Buyer's Guide.

**Estimate: \$100,000 - 200,000**





**281**  
**Iron Man's (Robert Downey, Jr.) Light-Up Distressed**  
**Mk42 Helmet**  
**Iron Man 3 (2013)**

Iron Man's (Robert Downey, Jr.) light-up distressed Mk42 helmet from Shane Black's superhero sequel Iron Man 3. The Mandarin (Guy Pearce) destroyed Tony Stark's Malibu mansion, including his many Iron Man suit and helmet builds.

This fiberglass helmet was likely never intended to be worn, and is believed to have been created for use on a puppet or as set decoration for the Stark Labs destruction scene. It is marked "CRASH MK42 HELMET" on the interior and painted ruby and gold. Internal electronics added after production for display purposes and powered via a toggle battery pack illuminate the helmet's frosted acrylic lenses. It is intentionally distressed throughout with nicks, scratches, and silver-color paint streaks to appear damaged.

Contains electronics; see electronics notice in the Buyer's Guide.

**Estimate: \$30,000 - 60,000**



**282**  
 Jane Foster's (Natalie Portman)  
 Cracked Mjolnir Hammer  
**Thor: Love And Thunder (2022)**

Jane Foster's (Natalie Portman) cracked Mjolnir hammer from Taika Waititi's sci-fi action sequel Thor: Love and Thunder. Foster reassembled Thor's (Chris Hemsworth) signature hammer Mjolnir to help him defeat Gorr (Christian Bale).

This 3D-printed hollow plastic hammer is painted silver with cracking and Asgardian runes engraved throughout, a striped gray and brown handle designed to resemble leather, and a brown leatherette strap. It is distinctly smaller than Mjolnir's intended for Thor, and leatherette was used as Portman is a vegan and refuses to work with products made from animal hides. This hammer exhibits minor chipped paint along the handle from production use and yellowing around the cracks. Dimensions: 8.5" x 5.25" x 20" (21.75 cm x 13.5 cm x 51 cm)

**Estimate: \$60,000 - 120,000**



Moviestore Collection Ltd / Alamy Stock Photo





**283**  
**Posed Sentinel VFX Reference Model Miniature on Display**  
**The Matrix Revolutions (2003)**

A posed sentinel VFX reference model miniature on display from the production of the Wachowskis' sci-fi action sequel The Matrix Revolutions. Hordes of sentinels took heavy fire from APUs and an EMP when they besieged Zion.

This lot comes from the collection of The Matrix Reloaded and Revolutions production manager L. Dean Jones, Jr. This ornately detailed squid-like model is one of a select few created by the Miniature Unit as an effects reference for the siege sequence. It features a cast resin head and body painted metallic gray with dull red eyes, front claws, and plated tentacles with clamped claws. The sentinel comes mounted via a metal rod to a custom display base textured and painted to resemble a large metal machine gear. It exhibits some yellow discoloration and grime from production, minor fractures to the resin, and flaking to the base from production use and handling. Dimensions: 20" x 20" x 15" (51 cm x 51 cm x 38.25 cm)

**Estimate: \$10,000 - 20,000**



**284**  
**Sentinel Filming Model Miniature**  
**The Matrix Revolutions (2003)**

A sentinel filming model miniature from the production of the Wachowskis' sci-fi action sequel The Matrix Revolutions. After breaking into Zion, hordes of sentinels fell from APU fire and a detonated EMP.

This lot comes from the collection of The Matrix Reloaded and Revolutions production manager L. Dean Jones, Jr. This squid-like sentinel is one of a select few created by the Miniature Unit to be dropped onto the model miniature Zion docks for low-angle photography during the siege sequence. It features a molded foam head painted metallic gray and inset with black nylon rope tentacles affixed with resin claws. It exhibits several missing claws, the tentacles are tied together, and the paint exhibits scuffing throughout from production use and handling. Dimensions: 27" x 6" x 3.5" (68.75 cm x 12.75 cm x 9 cm)

**Estimate: \$7,000 - 14,000**



27" (68.75 cm)

**285**  
**Armored Personnel Unit (APU) VFX Reference Model Miniature**  
**The Matrix Revolutions (2003)**

An Armored Personnel Unit (APU) VFX reference model miniature from the production of the Wachowskis' sci-fi action sequel The Matrix Revolutions. Hordes of sentinels took heavy fire from APUs when they besieged Zion.

This lot comes from the collection of The Matrix Reloaded and Revolutions production manager L. Dean Jones, Jr. Originally created by the Miniature Unit as an effects reference model for the siege sequence, this ornately detailed miniature was gifted to Jones by supervising art director Hugh Bateup on behalf of the Wachowskis after production. It is constructed primarily from cast resin with metal hinges and grating, all painted chrome-color and black and intentionally distressed by production to appear aged. It comes mounted via rods in the feet to a black wooden base. One of the miniature's hands snapped off following production, and it exhibits exposed resin from age. Dimensions: 19" x 10.5" x 24" (48.25 cm x 26.75 cm x 61 cm)

**Estimate: \$7,000 - 14,000**



**286**  
**Wall-Bursting Sentinel VFX Reference Model Miniature Display**  
**The Matrix Revolutions (2003)**

A wall-bursting sentinel VFX reference model miniature display autographed by the Miniature Unit of the Wachowskis' sci-fi action sequel The Matrix Revolutions. Sentinels burst through the walls protecting Zion.

This lot comes from the collection of The Matrix Reloaded and Revolutions production manager L. Dean Jones, Jr. This display is one of a select few made by the Miniature Unit in Alameda, CA, then given as a crew gift following production. It consists of an ornately detailed multimedia sentinel miniature painted metallic gray with red eyes and tentacles bursting through a wooden crate. The crate is labeled "Matrix Model Unit" on one side and inscribed to unit production manager L. Dean Jones with messages on the back by crew members Jenny Napier, Chris Symonds, Heidi Eri, Adam Schardein, Todd Fellows, Steak House, Robert "Boomer" McCann, Phil Brotherton, Tom Baker, and John Oster. The display exhibits several punctures, holes repaired with tape, cracking, and stains from exposure. Dimensions: 18" x 19" x 6" (45.75 cm x 48.25 cm x 15.25 cm)

**Estimate: \$6,000 - 12,000**

**287**  
Worm Guy Puppet Display  
**Men In Black (1997)**

A worm guy puppet display from Barry Sonnenfeld's sci-fi comedy Men in Black. Worm guys lounged in the breakroom at MIB headquarters while Agent K (Tommy Lee Jones) explained the agency to Jay (Will Smith).

This lot consists of a textured foam puppet made by Rick Baker's Cinovation with a fiberglass base painted beige and inset with black acrylic eyes, metal-reinforced antennae, and smaller arms. Mechanical wiring and cables designed to move the puppet are connected to a metal lever through the back. It comes mounted via a metal rod to a wooden base painted black. This lot has undergone sympathetic restoration to address extensive cracking and chipping in the foam from age. The head exhibits minor articulation, but remains significantly fragile and is not recommended for operation. Dimensions: 18" x 16" x 38" (45.75 cm x 40.75 cm x 96.75 cm)

Contains electronics and mechanical components; see notice in the Buyer's Guide.

**Estimate: \$10,000 - 20,000**

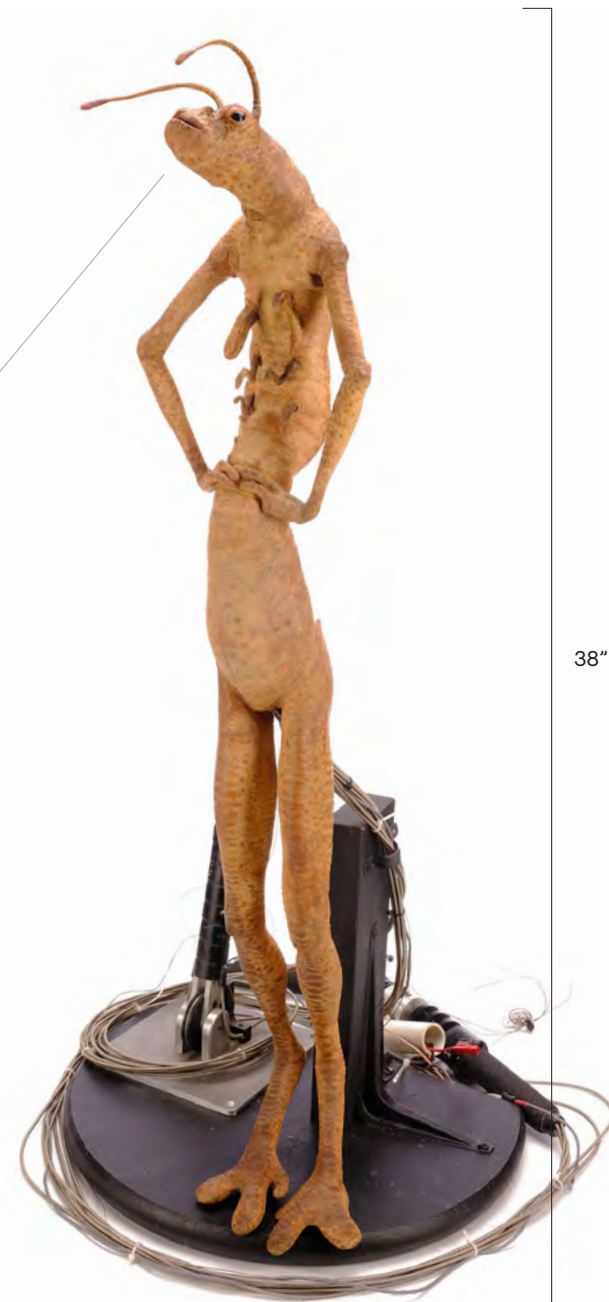

38" (96.75 cm)

**288**  
Agent Kay's Stunt Rocket Blaster  
**Men In Black II (2002)**

Agent Kay's stunt rocket blaster from Barry Sonnenfeld's action comedy Men in Black II. Agent Kay and Agent Jay went to Agent Kay's former apartment to acquire weapons to rescue Laura from Serleena.

This lot consists of a static, futuristic-looking rubber foam blaster. Painted a silver-color, this blaster features a grated area on top painted blue, a black textured front grip, and a shoulder rest. Agent Kay carried this blaster style in the film, and this style is depicted in the film's posters. This lot exhibits notable marks, cracking and pitting, and paint marks. Dimensions: 40" x 12" 4" (101 cm x 30.5 cm x 10.25 cm)

**Estimate: \$3,000 - 6,000**



**289**  
Agent Jay's Stunt Three-Barrel Blaster  
**Men In Black II (2002)**

Agent Jay's stunt three-barrel blaster from Barry Sonnenfeld's action comedy Men in Black II. Agent Kay and Agent Jay went to Agent Kay's former apartment to acquire weapons to rescue Laura from Serleena.

This lot consists of a static, futuristic-looking rubber foam blaster. Painted a silver-color, this blaster features a front grip for stability, a textured grip and a textured shoulder rest. Agent Jay carried this blaster style in the film. This lot exhibits notable marks, cracking and pitting, and notable paint marks. Dimensions: 32" x 12" x 6" (81.5 cm x 30.5 cm x 12.25 cm)

**Estimate: \$1,000 - 2,000**

31" (78.75 cm)



**290**  
Static Worm Guy Puppet  
**Men In Black 3 (2012)**

A static worm guy puppet from Barry Sonnenfeld's sci-fi comedy sequel Men in Black 3. An iconic species specific to the franchise, the coffee-loving "worm guys" appeared in all Men in Black films.

This lot consists of a foam latex worm guy with highly detailed skin painted in various shades of light brown with dark brown spots over an internal armature mounted to a metal display base. The foam latex exhibits minimal signs of wear including some cracking, while the base exhibits some scuffing and grime. Dimensions: 11" x 9.5" x 31" (28 cm x 24.25 cm x 78.75 cm)

**Estimate: \$8,000 - 16,000**



**291**  
**Knights of the Round Table Helmet**  
**Monty Python And The Holy Grail**  
**(1975)**

A Knights of the Round Table helmet from Terry Gilliam's and Terry Jones' Arthurian comedy film Monty Python and the Holy Grail. In a musical cutaway scene, the Knights of the Round Table wore their helmets as they danced and sang in Camelot.

The fiberglass helmet is painted gray and features a T-shaped opening for the eyes and mouth and ear holes in both sides. The inside of the helmet is lined with foam for added comfort. The helmet exhibits scuffing, cracking, and a piece broken from the bottom edge.

**Estimate: \$5,000 - 10,000**



**292**  
**Eliza Rescue Ship Model Miniature**  
**Moon (2009)**

An Eliza rescue ship model miniature from Duncan Jones' science-fiction film Moon. A ship containing a rescue team known as "Eliza" was dispatched to Sarang Station to repair a damaged helium-3 harvester.

Built by renowned film and television model maker Bill Pearson and his team, the ship is constructed of resin and plastic with many small details adhered throughout and 10 thick landing legs on which the ship stands. The entire model is painted dark gray to resemble metal with subtle aging applied throughout. It exhibits minimal wear from production. Dimensions: 23" x 14.5" x 13.25" (59 cm x 37 cm x 34 cm)

**Estimate: \$4,000 - 8,000**



**293**  
**Ray Tanner's (Bruce Campbell) Spacesuit**  
**Moontrap (1988)**

Ray Tanner's (Bruce Campbell) spacesuit from Robert Dyke's sci-fi film Moontrap. Ray wore his spacesuit while he explored the moon and while he was in space.

This costume consists of a soft padded helmet made of white canvas cloth with a clear acrylic visor, two non-functional resin lights, and a foam neck ring; a plastic and foam collar with metal hardware; a padded white canvas cowl neck long-sleeve torso top with a patch on each arm; padded white canvas bottom trousers; white canvas gloves with a beige leather palm and gray rubber fingertips; and shoes with white canvas boot covers, as well as a spacesuit backpack with resin components and a "NASA" patch. The costume interior and boots feature tags from Center Theatre Group with "Moontrap Bruce Campbell" hand-marked in black ink. This lot exhibits a build up of grime, discoloration, and fragile components due to age.

**Estimate: \$6,000 - 12,000**



**294**  
**"Spruce Springsteen" Official Henson Muppet Display**  
**The Muppets Franchise (1975-Present)**

A "Spruce Springsteen" official Henson Muppet display from the Muppet Workshop. Muppet designer Ed Christie designed and created this parody muppet for the Night of 100 Trees charity event in 1988.

Originally part of a larger display sold at the charity benefit, this lot consists of an official Henson muppet displayed on a black wooden base with a black felt-covered pole. Tree-shaped and wearing a silver-color and sparkly blue necktie, this muppet is made of green faux fur lined with green polyblend fabric. It features foam and felt eyes, a felt mouth, and an interior hand-sewn hand-marked tag "Henson Assoc, Inc 1988 - All Rights Reserved" in black ink. A white ribbon tag signed by Jim Henson is attached to the back of the muppet. This lot exhibits a build up of grime, and mild matted fur. Dimensions: 16" x 12" x 25" (40.75 cm x 30.5 cm x 63.5 cm)

**Estimate: \$5,000 - 10,000**

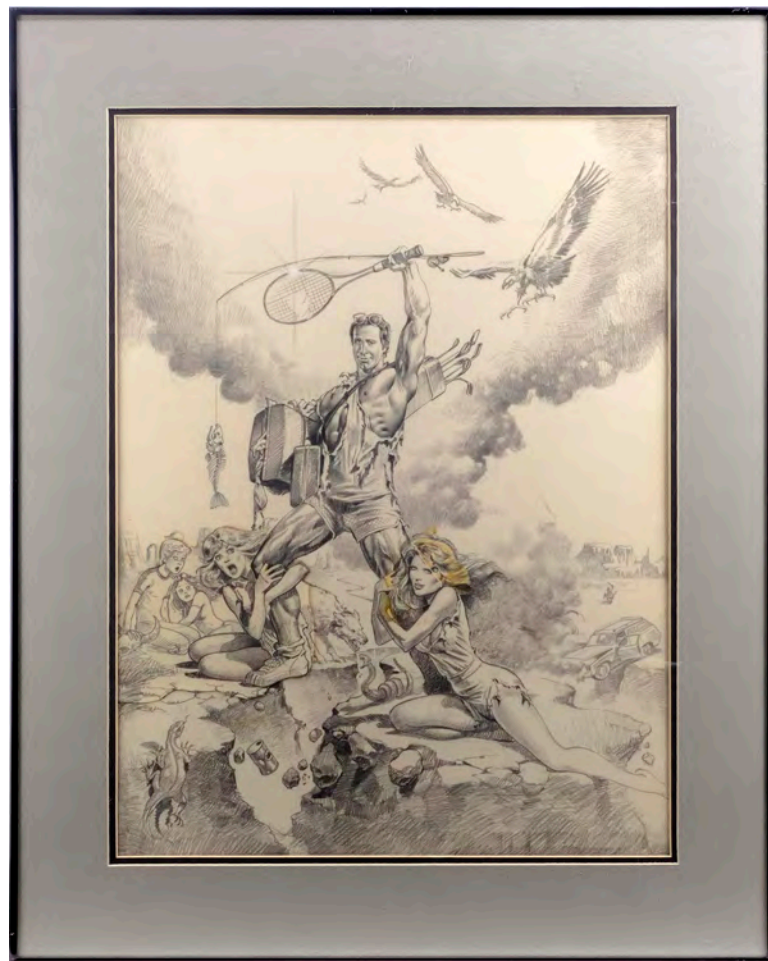

**295**  
Framed Hand-Drawn Boris Vallejo Poster Prelim  
**National Lampoon's Vacation (1983)**

Framed prelim artwork for a poster for Harold Ramis' comedy classic National Lampoon's Vacation hand-drawn by fantasy artist Boris Vallejo. The prelim depicts Ellen (Beverly D'Angelo) and The Girl in the Ferrari (Christie Brinkley) holding on to muscular Clark Griswold (Chevy Chase) with references to several of the film's key setpieces behind them.

This prelim is rendered in graphite with yellow pencil touch-ups on illustration board. It comes mounted behind plexiglass in a custom gray matte-lined frame. Also featured is a partial paste-over on Brinkley's face used to exact her likeness in the drawing. The frame exhibits minor scuffs from handling. Dimensions: 24.25" x 30.25" x 1" (61.75 cm x 76.5 cm x 2.5 cm)

Sold without copyright; see notice in the Buyer's Guide.

**Estimate: \$10,000 - 20,000**



**296**  
Framed Hand-Drawn Boris Vallejo Poster Prelim  
**National Lampoon's European Vacation (1985)**

Framed prelim artwork for a poster for Amy Heckerling's comedy sequel National Lampoon's European Vacation hand-drawn by fantasy artist Boris Vallejo. The prelim depicts Ellen (Beverly D'Angelo), Audrey (Dana Hill), and Rusty (Jason Lively) Griswold holding on to a muscular Clark (Chevy Chase) with iconic European destinations behind them.

This prelim is rendered, signed, and dated "Boris 85" in graphite on illustration board. It comes mounted behind plexiglass in a custom gray matte-lined frame. Additionally, this piece was featured in the 1985 book "Fantasy Art Techniques" to illustrate Vallejo's creative process. The prelim is applied with white correction fluid in the bottom left corner and exhibits stray pencil markings in its margins. Dimensions: 24.25" x 30.25" x 1" (61.75 cm x 76.5 cm x 2.5 cm)

Sold without copyright; see notice in the Buyer's Guide.

**Estimate: \$6,000 - 12,000**



11.5" (29.5 cm)

**297**  
Resolute Desk Puzzle Piece  
**National Treasure: Book Of Secrets (2007)**

A Resolute desk puzzle piece from Jon Turteltaub's action-adventure sequel National Treasure: Book of Secrets. After breaking into Buckingham Palace, Benjamin Gates (Nicholas Cage) and Dr. Abigail Chase (Diane Kruger) discovered the puzzle piece in the Resolute desk owned by the Queen.

This piece is made of resin hand-painted to resemble wood and intentionally distressed to appear hundreds of years old. The lot exhibits some wear from production use, with some scuffing to the paintwork revealing the resin beneath. Dimensions: 11.5" x 4.75" x 0.75" (29.5 cm x 12 cm x 2 cm)

**Estimate: \$7,000 - 14,000**



**298**  
Pippi Longstocking's (Tami Erin) Whimsical Costume  
**New Adventures Of Pippi Longstocking (1988)**

Pippi Longstocking's (Tami Erin) whimsical costume from Ken Annakin's fantasy adventure film The New Adventures of Pippi Longstocking. Pippi wore her whimsical costume throughout her time in Rocksbj.

From the collection of actress Tami Erin, this costume consists of a pair of blue and orange fleece stockings with patchwork connected with white elastic stirrups to pastel green bloomers with a white lace trim; a red nylon dress with yellow and purple patches; a pastel lavender apron with a floral design and a pink plaid patch; and a pair of brown leather shoes marked "E MARY ELLEN 7 1/2 M." This lot exhibits discoloration and worn elastic on the stirrups.

**Estimate: \$6,000 - 12,000**



**299**  
New York Knights Coach Letterman Jacket  
**The Natural (1984)**

A New York Knights coach letterman jacket from Barry Levinson's sports drama The Natural. Roy Hobbs (Robert Redford) became an unexpected star player for the Knights, who wore matching team jackets throughout the film.

This custom Empire Sporting Goods button-up letterman jacket features a royal blue woolen front with a matching elasticated collar, hem, and cuffs, blue satin interior lining, and tan leather sleeves. The chest and back are emblazoned with blue, orange, and white team patches reading "Knights." The jacket exhibits stains on the left side and sleeve, stiffening to the elastic, and some fraying on the hem from production wear and age.

**Estimate: \$5,000 - 10,000**

**300**  
 Robert Redford-Autographed Roy Hobbs' Rehearsal "Wonderboy" Bat  
**The Natural (1984)**

A Robert Redford-autographed Roy Hobbs' rehearsal "Wonderboy" bat from Barry Levinson's sports drama The Natural. Baseball star Hobbs' signature bat Wonderboy was carved from the wood of a tree that was struck by lightning at the same time his father (Robert Rich III) suffered a heart attack. While the standard Wonderboy bats featured in the film were wood-burned, the text and symbol on this example were carved in and then outlined with marker; the bat was used during production for rehearsals, and may have been one of the early prototypes for the wood-burned bats seen on screen.

When filming wrapped on the movie, this bat was signed and inscribed by Redford and gifted to Chris Pollack - the son of the film's costume designer Bernie Pollack and nephew of the producer Sydney Pollack. The inscription reads: "Dear Chris, This is my bat and it is impervious to your pitching - Robert Redford (Roy Hobbs)." Chris was an aspiring baseball player himself and previously spent time on set during filming, where he got to know Redford and other cast members.

A few years later, when Chris Pollack signed with the Montreal Expos and entered professional baseball, Redford sent him a letter of congratulations stating "I know it was the bat," a joke that this Wonderboy prop bat was the reason for Pollack's success.

Designed by property master Barry Bedig from period-specific Louisville Sluggers, this light brown oak bat features "Wonderboy" and a lightning-shaped "W" symbol carved into it. Also included is a color photograph of Chris Pollack and Robert Redford on set, which is signed and inscribed "Can you spot the Natural? Fondly, Robert Redford"; the congratulations letter Redford sent to Pollack in 1987; two strips of negatives for photos taken on set while Pollack visited enclosed in an envelope printed with a "The Natural" logo in the upper left corner; an invitation to the film's premiere enclosed in a Tristar envelope with a matching production logo; an RSVP card to the invitation; and a site map for the studio premiere.

The Natural received four Academy Award® nominations, including Best Actress in a Supporting Role for Glenn Close, Cinematography, Art Direction, and Music. It is frequently cited as one of the best baseball movies ever made. The bat exhibits light scratches from use and fading from its age. Dimensions: 32.5" x 2.5" x 2.5" (82.75 cm x 6.5 cm x 6.5 cm)

**Estimate: \$15,000 - 30,000**

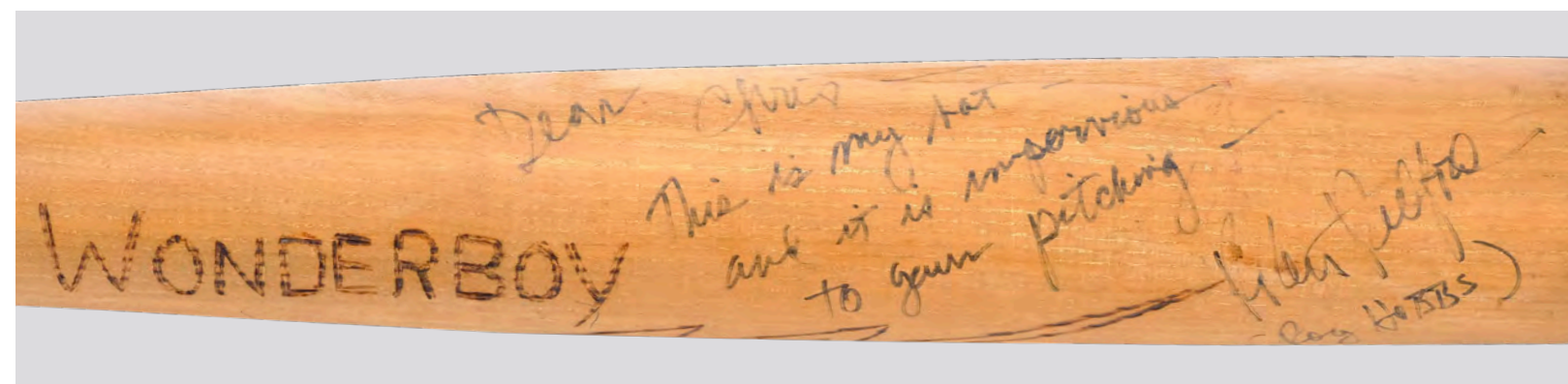
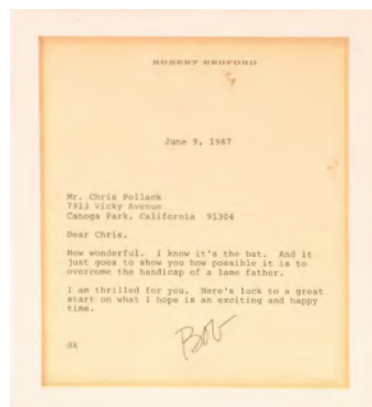

**300B**  
 Roy Hobbs' (Robert Redford) Custom-Made Left Handers' Period Fielding Glove and Ball  
**THE NATURAL (1984)**

A vintage 1910-1930s style baseball glove and baseball from Barry Levinson's sports drama The Natural. This period-correct glove was custom-made for Roy Hobbs' (Robert Redford) use in the film. At the start of production, a batch of left handers' gloves was fabricated specifically to be used by Hobbs, as Redford is left handed and was one of the few "lefties" in the film. Redford ultimately used several different gloves across different scenes in the film, and the few other left handed performers in the film who needed gloves for baseball sequences may have used them as well. The Hobbs gloves also had additional padding installed in the palm for Redford.

This lot consists of a red-brown leather baseball glove and Spalding No.1 baseball, both recreated by Hand Prop Room in the authentic 1910s to 1930s style. The lefthander's leather glove features an adjustable wrist strap with brass button closure, and extra padding throughout palm and fingers. The baseball is made of white leather with red and black stitching along the seams, surrounding a cork center. It features the Spalding logo and "Official National League" logo printed in black.

Both pieces are intentionally distressed to appear worn with fading, scuffing, and staining throughout. A Letter of Authenticity from Hand Prop Room is included. The glove exhibits signs of leather repair between thumb and index finger, along with light cracking and creasing, with green oxidation residue around the button. The baseball exhibits early signs of minor leather cracking and marking from use and age.

Dimensions: (glove) 9.75" x 9.5" x 3.5" (24.75 cm x 24.25 cm x 9 cm); (baseball) 2.75" x 2.75" diameter (7 cm x 7 cm)

**Estimate: \$8,000 - 16,000**

**301**  
 Hand-Drawn Roy Hobbs (Robert Redford) Costume Designs with Printed Illustration  
**The Natural (1984)**

Six Roy Hobbs (Robert Redford) costume designs hand-drawn by costume illustrator Barbara Black-Sterne and a printed Hobbs illustration for Barry Levinson's sports drama The Natural. Hobbs' costumes were designed by Bernie Pollack, then rendered by Black-Sterne in mixed media.

This set consists of three hand-drawn sketches of various Hobbs costumes; three matted hand-drawn sketches with handwritten annotations scattered throughout; a printed copy of Hobbs in his baseball uniform; and a sheet of fabric samples. The set exhibits discoloration, lifted adhesive, and rips and tears throughout the edges. Dimensions: (each) 22" x 17" (56 cm x 43.5 cm)

Sold without copyright; see copyright notice in the Buyer's Guide.

**Estimate: \$2,500 - 5,000**



"Baseball Uniform Costume Design is a Production Copy; Other Designs are Hand-Drawn"

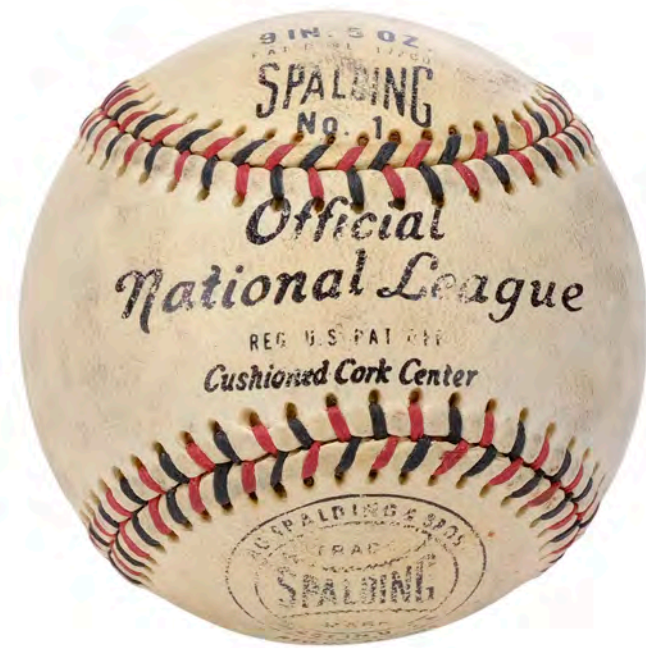

8.75" (22.25 cm)

**302**  
Spalding No. 1 Baseball  
**The Natural (1984)**

A Spalding No. 1 baseball from Barry Levinson's sports drama *The Natural*. Baseballs were used throughout the film, including when Roy Hobbs (Robert Redford) hit his climactic game-winning home run.

Principle and background performers used custom-made, exacting recreations of 1932-1933-era Spalding baseballs during filming and batting practice throughout production. This baseball features an off-white leather skin with red and blue stitching, a cushion cork center, and period-correct "Spalding" and "Official National League Reg. U.S. Pat. Off." logos stamped in blue. Also included are a printed copy of a continuity photograph of Hobbs and a Certificate of Authenticity from the film's prop master and prop house. The ball is intentionally distressed by production to appear well-worn with fading print, scuffing, and staining throughout. Dimensions: 3" x 3" x 3" (7.75 cm x 7.75 cm x 7.75 cm)

**Estimate: \$2,000 - 4,000**



**303**  
Screen-Matched Christmas Town House Facade  
Model Miniature  
**The Nightmare Before Christmas (1993)**

A screen-matched Christmas Town house facade model miniature from Henry Selick's stop-motion fantasy musical *The Nightmare Before Christmas*. Distinctive striping screen-matches this house to when Jack Skellington (Danny Elfman and Chris Sarandon) first discovered Christmas Town.

This Christmas Town house is made of red hand-painted foam poster board base with green painted wooden trim and door and white clay to resemble a snow-covered roof with a red painted clay chimney. This house features five windows, each with a red and white candy cane-painted board trim and a green painted stick for the window panes. The inside of the house is painted yellow to resemble a glow in the house through the windows and five holes around the top front window. This house exhibits imperfect paint patterns and grime from age. Dimensions: 2.5" x 4.5" x 8.75" (6.5 cm x 11.5 cm x 22.25 cm)

**Estimate: \$4,000 - 8,000**



36" (91.5 cm)

**304**  
Screen-Matched Halloween Town Skyline  
Model Miniature  
**The Nightmare Before Christmas (1993)**

A screen-matched Halloween Town skyline model miniature from the production of Henry Selick's stop-motion fantasy musical *The Nightmare Before Christmas*. After a lifetime of living in Halloween Town, Jack Skellington (Chris Sarandon) discovered a new way of life in Christmas Town. Details in the sculpting of the hill screen-match to the shot of the skyline in the film's opening musical number.

Created for shots featuring Halloween Town's spiky, dark silhouette, this miniature is constructed from black-painted plaster buildings with high-gloss orange nylon windows that shine when activated by light, gray-painted wooden details, and gray-painted metal wire staircases between the buildings. The skyline has been affixed to a canvas backing, created for display, featuring a hand-painted black and gray starry sky with a pastel yellow moon containing the silhouette of Oogie Boogie (Ken Page) and a placard labeled "Used for the opening of the film" at the bottom. The lot exhibits minor paint flaking and signs of sympathetic restoration, including two of the rear buildings being foam replicas added to complete the piece. Dimensions: 36" x 36" x 2" (91.5 cm x 91.5 cm x 5 cm)

**Estimate: \$7,000 - 14,000**







6.5" (16.5 cm)

**305**  
Screen-Matched Oogie Boogie SFX Dice & Snake  
**The Nightmare Before Christmas (1993)**

Oogie Boogie's screen-matched SFX dice and snake from Henry Selick's fantasy musical *The Nightmare Before Christmas*. After the "Kidnap the Sandy Claws" song, Oogie Boogie (Ken Page) rolled red dice in the menacing shadow of his face. This pair of dice screen-match to a close-up of a black-and-white snake slithering through the holes of one die.

The oversized SFX dice are made from red-painted MDF with an open side and black fabric taped to the interior to black out the dice's holes. Both display carved skull-like imagery, etched scratches, and black painted shading to give them texture and an aged appearance. One die includes the stop-motion puppet snake made of painted black-and-white foam formed around a metal armature for posing and feeding through the die's holes. One die exhibits a small area of MDF splintering and glue remnants on the interior from production use. The snake exhibits fragility, with minor cracks from the hardening of the foam due to age. This lot is accompanied by a Certificate of Authenticity, which has been signed by Ken Page. Dimensions: (die with snake) 6.5" x 6.5" x 8" (16.5 cm x 16.5 cm x 20 cm)

**Estimate: \$20,000 - 40,000**



**306**  
Freddy Krueger's (Robert Englund) Bloodied  
Razor-Claw Glove  
**Nightmare On Elm Street 5, A: The Dream Child (1989)**

Freddy Krueger's (Robert Englund) bloodied razor-claw glove from Stephen Hopkins's gothic slasher film *A Nightmare on Elm Street 5: The Dream Child*. Freddy wore his iconic glove throughout the film as he terrorized Alice (Lisa Wilcox) and her friends using Alice's unborn baby as a conduit.

This lot consists of a tan-color leather glove with the tips and palm cut out. It also features the four iconic stainless steel razors, affixed to metal finger plates with a single joint point, riveted to a backplate. The finger blades, plates, and glove back plate are fastened with brass-color rivets. The metal plates feature decorative metal accents. The inside of the glove is hand-marked with "Ryan Effner 1989." Also included is a letter of authenticity from the Ryan Effner Collection, and a secondary certificate of authenticity. Production purposefully distressed this glove to make it look bloody, grimy, and tarnished. This glove exhibits discoloration and notable residue.

Blades were dulled by production.

**Estimate: \$20,000 - 40,000**



**307**  
**Freddy Krueger (Robert Englund) Makeup Appliances**  
**Nightmare On Elm Street Part 2, A: Freddy's Revenge**  
**(1985)**

A set of Freddy Krueger (Robert Englund) makeup appliances from Jack Sholder's horror sequel *A Nightmare on Elm Street 2: Freddy's Revenge*. Special effects makeup appliances were used to give actor Robert Englund the burned appearance of Krueger for the sequel.

This seven-piece foam latex appliance set is painted in extensive detail to resemble pink and orange burned and scarred flesh, and includes one large neck piece, one sculpted nose piece with nostrils, two cheek sections with ears, one forehead appliance, one top of the head appliance, and one additional temple piece. The appliances come attached to a custom black plastic head with an acrylic base added after production. The foam latex has hardened with age and exhibits cracking and peeling along the edges. Dimensions: 17" x 10" x 7" (43.25 cm x 25.5 cm x 18 cm)

**Estimate: \$5,000 - 10,000**



**308**  
**Dan's (Danny Hassel) SFX Motorcycle Arm**  
**Nightmare On Elm Street 5, A: The Dream Child**  
**(1989)**

Dan's (Danny Hassel) SFX motorcycle arm from Stephen Hopkins' gothic slasher *A Nightmare on Elm Street 5: The Dream Child*. While in a dream, Dan drove a motorcycle before it began to meld itself to him.

This lot consists of one resin and fiberglass arm with an internal metal rod and clear plastic tubing. Sculpted to grip the handlebar of a motorcycle with exposed muscles, this arm features metal wire and coiled tubing interwoven throughout. It was painted a metallic gray with red and orange tones to appear like a rusty machine. The clear tubes for pass-through of stage blood through holes in the arm have solid white plastic attachments and strips of duct tape attached, whereas the metal cable allowed the skin (not present) to be ripped from the arm as a practical effect. This lot exhibits pitting in the resin and notable white residue, as well as discoloration and chipped paint. Dimensions: 23.5" x 18" x 6" (59.75 cm x 45.75 cm x 15.25 cm)

**Estimate: \$7,000 - 14,000**



**309**  
**Freddy Krueger's (Robert Englund)**  
**Screen-Matched Prosthetic Razor-**  
**Claw Glove**  
**Freddy's Dead: The Final**  
**Nightmare (1991)**

Freddy Krueger's (Robert Englund) screen-matched prosthetic razor-claw glove from Rachel Talalay's slasher sequel *Freddy's Dead: The Final Nightmare*. This glove screen-matches to when Maggie Burroughs (Lisa Zane) stabbed Freddy with his own glove, while the prosthetic hand inside the glove was used in a separate scene when Freddy's hand spins like a blender.

This lot consists of a brass-color metal-plated tan leather glove with four foam finger razors adhered to its fingertips and hand-painted to resemble steel, as well as the red hem of Freddy's shirt, all dressed over a foam and latex hand prosthetic. The finger plates are riveted together and to the backplate. A dowel beneath the prosthetic designed to allow it to spin comes mounted to a Freddy-themed display base.

During sympathetic restoration conducted by Tom Spina Designs, two finger blades were added, as they had been cut off. Production intentionally distressed this prosthetic to appear grimy and aged. This lot exhibits discoloration, notable residue marks, creasing and fragility. Dimensions: 8" x 8" x 16" (20.5 cm x 20.5 cm x 40.75 cm)

**Estimate: \$20,000 - 40,000**



**310**  
**Freddy Krueger's (Robert Englund)**  
**Prosthetic Hand**  
**Freddy's Dead: The Final**  
**Nightmare (1991)**

Freddy Krueger's (Robert Englund) prosthetic hand from Rachel Talalay's slasher sequel *Freddy's Dead: The Final Nightmare*. In the Dream World, Kathryn Krueger (Lisa Zane) broke Freddy's hand in half during their climatic fight.

Created for the hand-breaking scene, this foam and latex hand prosthetic is ornately detailed with wrinkles, scars, and cuticles. It comes mounted via a metal rod to a wooden display base with a red and green striped Krueger-themed pattern. This lot exhibits pitting, rips and tears, a protruding metal nail, cracks in the wood base; and fragility from age. Dimensions: 5" x 5" x 13" (12.75 cm x 12.75 cm x 33 cm)

**Estimate: \$3,000 - 6,000**



**311**  
**Lennox Lewis' Cast-Autographed**  
**Boxing Gloves**  
**Ocean's Eleven (2001)**

Lennox Lewis' cast-autographed boxing gloves from Steven Soderbergh's crime-thriller film *Ocean's Eleven*. Lewis wore his boxing gloves during a boxing match against Vladimir Klitschko in the Desert Storm fight that coincided with Danny Ocean's (George Clooney) heist.

This lot consists of one Desert Storm "Standing Only" ticket featuring Lewis and Klitschko and three red leather boxing gloves with white nylon laces. The boxing gloves are cast-autographed by Lewis, Elliot Gould, Carl Reiner, Eddie Jemison, George Clooney, Scott Caan, Brad Pitt, Julia Roberts, Don Cheadle, Casey Affleck, Bernie Mac, Matt Damon, Vladimir Klitschko, and Andy Garcia. This lot exhibits minor peeling material on two gloves. Dimensions: 12" x 6.5" x 4.5" (30.5 cm x 16.5 cm x 11.5 cm)

**Estimate: \$5,000 - 10,000**



George Clooney Autograph



Brad Pitt Autograph



**312**  
**Anne Boleyn's (Natalie Portman)**  
**Screen-Matched Costume**  
**The Other Boleyn Girl (2008)**

Anne Boleyn's (Natalie Portman) screen-matched costume from Justin Chadwick's historical melodrama *The Other Boleyn Girl*. This dress screen-matches to various scenes throughout the film in which Anne wore her Tudor-style blue dress. Three years after portraying her, Portman won the Academy Award® for Best Actress for Darren Aronofsky's *Black Swan*.

This dress features a blue shot silk bodice and skirt with draped velvet sleeves, a square neckline hemmed in black velvet, and metal embellishments and faux jewels hand-sewn throughout. Featuring a floor-length skirt and a patterned kirtle, the dress is lined in black chiffon and beige canvas. The front of the dress features a combination of hidden snaps and hook-and-eye closures. This costume exhibits discoloration on the interior.

**Estimate: \$4,000 - 8,000**



Cinematic Collection / Alamy Stock Photo

**313**  
**Cursed Aztec Coin**  
**Pirates Of The Caribbean: The**  
**Curse Of The Black Pearl (2003)**

A cursed Aztec coin from Gore Verbinski's adventure film *Pirates of the Caribbean: The Curse of the Black Pearl*. Stacks of coins filled the caverns of Isla De Muerta when Barbossa's (Geoffrey Rush) crew returned Aztec gold taken years earlier to finally lift their curse.

This coin is made of metal with a gold-color finish, gold-color sparkles glued on for extra shine, a skull-and-sun motif engraved on front, and a geometric pattern engraved on back. A LOA from a crewmember is included. It exhibits worn paint from production use. Dimensions: 1.5" x 1.5" x 0.25" (0.75 cm x 0.75 cm x 0.25 cm)

**Estimate: \$4,000 - 8,000**





**314**  
 Captain Hector Barbossa's  
 (Geoffrey Rush) Ring  
**Pirates Of The Caribbean: The  
 Curse Of The Black Pearl (2003)**

Captain Hector Barbossa's (Geoffrey Rush) ring from Gore Verbinski's adventure-fantasy film *Pirates of the Caribbean: The Curse of the Black Pearl*. Captain Barbossa wore his ring when he examined Will Turner's (Orlando Bloom) pirate coin.

This lot consists of a gold-colored metal ring featuring a tiger face emblem against a matte black backing; a red leatherette and gold-color metal ring box; a red velvet bag; an 8" x 10" color-printed promotional image of Barbossa; and a Disney Auctions Certificate of Authenticity. The leatherette of the ring box exhibits some wear and the bag has minor stains. Dimensions: (box) 3" x 2" x 1.75" (7.75 cm x 5 cm x 4.5 cm)

**Estimate: \$3,000 - 6,000**



**315**  
 Captain Hector Barbossa's (Geoffrey Rush) Stunt Flintlock Pistol  
**Pirates Of The Caribbean: The Curse Of The Black Pearl (2003)**

Captain Hector Barbossa's (Geoffrey Rush) stunt flintlock pistol from Gore Verbinski's adventure film *Pirates of the Caribbean: The Curse of the Black Pearl*. Barbossa fired his pistol at Pintel (Lee Arenberg) to see whether the curse had been lifted.

This lot consists of one static urethane stunt pistol. This pistol features intricate details on the frame, including a skull sculpt on the pommel, painted in silver- and gold-color. It also features a flint in the lock painted to resemble rock, and a belt hook on the other side. This lot exhibits discoloration, notable paint marks, cracking and pitting, and loose components. Dimensions: 20" x 5" x 2.5" (51 cm x 12.75 cm x 6.5 cm)

**Estimate: \$3,000 - 6,000**



**316**  
 Roach's (James Le Gros) Richard Nixon Mask Δ  
**Point Break (1991)**

Roach's (James Le Gros) Richard Nixon mask from Kathryn Bigelow's action thriller *Point Break*. Roach wore his mask representing Richard Nixon when he robbed banks with his gang, the Ex-Presidents.

Academy Award®-winning special effects group Amalgamated Dynamics, Inc. ADI created an alternate version of the Nixon mask, but masks of this hand-painted latex style ultimately appeared on screen. It exhibits rigidity from age with a scratch on the nose, stains on the cheek, and tackiness to the interior from production.

**Estimate: \$3,000 - 6,000**



**317**  
 Grommet's (Bojessse Christopher)  
 Lyndon B. Johnson Mask  
**Point Break (1991)**

Grommet's (Bojessse Christopher) Lyndon B. Johnson mask from Kathryn Bigelow's action thriller *Point Break*. Grommet wore his mask representing Lyndon B. Johnson when he robbed banks with his gang, the Ex-Presidents.

This hand-painted latex Johnson mask was cast and padded with foam by Academy Award®-winning special effects group Amalgamated Dynamics, Inc. It exhibits rigidity from age and grime residue from exposure.

**Estimate: \$3,000 - 6,000**

**318**  
**Screen-Matched Evil Clown Doll**  
**Poltergeist (1982)**

A screen-matched evil clown doll from Tobe Hooper's supernatural horror film *Poltergeist*. As the supernatural occurrences began in the Freeling home, Robbie Freeling's (Oliver Robins) clown doll grabbed and dragged him under the bed where it tried to strangle him. The details in the face paint screen-match to shots of the doll attacking Robby under the bed and it is believed this is the only evil clown doll from the film.

*Poltergeist* became the eighth-highest-grossing film of 1982 and nominated for multiple 1983 Academy Awards®, including Best Visual Effects. In the decades following, the film has inspired numerous sequels, a 2015 remake, and various parodies and homages, with both the *New York Times* and American Film Institute ranking it in their top film lists.

Originating from a source close to production, this lot consists of a complete clown doll with an evil face made by dollmaker Annette Little. During pre-production, one complete clown doll was made with a smiling, friendly face, along with two other heads; with one having a distinctly malevolent-looking face and one notably "evil" looking face. Later, a second complete doll body was made and attached to the evil clown head. The second malevolent head did not appear on film and this evil clown doll was used once the clown turned evil. Over the course of filming Robbie's scene, the clown dolls suffered a degree of damage that production repaired between takes. These cracks to the plaster head can be seen on screen in several shots.

This clown doll features a plaster head with a hand-painted face and synthetic orange hair. It is hand-sewed onto the body by holes along the neckline. Both the hat and body are made of a poly-blend sateen fabric with decorative stars and moons adhered, internal wire armatures, and polyfill stuffing. The hat is believed to be from the happy version of the clown doll rather than the evil version; it was affixed to this clown doll during production, but after the evil clown sequence was shot. The design of this particular doll has exaggerated features such as a rounder body and longer limbs. The seams of the frills and vest still retain their original blue color, while the majority of the fabric on the cuffs and hat has faded over the years from the strong blue to a much softer pink tone. Also included is a promotional photograph of the Freeling family signed by Robins.

This doll exhibits cracks in the plaster head from filming, notable glue residue from on-set repairs, torn fabric, frayed threads, discoloration, and faded color. Dimensions: 53" x 18" x 7" (134.75 cm x 45.75 cm x 18 cm)

**Estimate: \$200,000 - 400,000**









**319**  
Visual Effects Screen-Matched  
Chainsaw  
**Poltergeist II: The Other Side**  
**(1986)**

A visual effects screen-matched chainsaw from Brian Gibson's supernatural horror film Poltergeist II: The Other Side. The imperfect melting on the chainsaw's grill screen-matches this chainsaw from when the Freeling's tried to escape in their car.

This lot consists of one Partner Brand P100 chainsaw and two photographs. Composed of metal and a painted red chassis, this chainsaw was modified with stepper motors for visual effects work and was shot single frame at a time for the sequence. Printed on U.S. letter size 8.5" x 11" (22 cm x 28 cm) paper, one picture consists of a sepia-tone, behind-the-scenes photo, and the other consists of a full-color still from the film. This lot exhibits scratches, exposed wires, discoloration, chipped paint, and notable grime. Dimensions: 41" x 16" x 13" (104 cm x 40.75 cm x 33 cm)

Contains electronics and mechanical components; see notice in the Buyer's Guide.

**Estimate: \$5,000 - 10,000**



**320**  
Hawkins' (Shane Black)  
Communication Backpack and  
Satellite  
**Predator (1987)**

Hawkins' (Shane Black) communication backpack and satellite from John McTiernan's action-horror film Predator. Hawkins carried and used his communication backpack and satellite when he called in his unit's position and situation against Russian military advisors.

Originally from the collection of Joel Silver, this lot consists of a black rayon backpack with a black-painted metal enforced and padded backing. Inside the backpack is a brown resin dial system taped to styrofoam with a metal and paper insert and an exterior pocket that is enforced with a polyvinyl tube for the collapsible gray rayon and resin satellite with a black metal tripod. This lot exhibits discoloration and chipping paint from age. Dimensions: 15" x 11.5" x 23" (38.25 cm x 29.25 cm x 58.5 cm)

**Estimate: \$8,000 - 16,000**

# Propstore

# Wanted

## Props, Costumes and Artifacts from Movies and Television

Sell Your Memorabilia with Propstore to  
Maximize Your Return

### Star Wars: The Empire Strikes Back (1980)

Original Painted Concept  
Artwork

sold for £53,125 (\$70,125)

incl. bp



Propstore CA Bond # 72BSBGU4116

[propstore.com/sell](https://propstore.com/sell)





**321**  
**Light-Up Spacesuit with Fifield's**  
**(Sean Harris) Photo-Matched**  
**Chestpack**  
**Prometheus (2012)**

A light-up spacesuit with Fifield's (Sean Harris) photo-matched chestpack from Ridley Scott's sci-fi prequel Prometheus. Uncomfortable with the team's discovery, Millburn (Rafe Spall) and Fifield (Sean Harris) attempted to return to Prometheus on their own, but wound up lost inside the structure and were attacked by a snake-like creature. The helmet and chest armor of this spacesuit photo-match specifically to Sean Fifield's while he was in the structure.

Designed by Janty Yates, this costume consists of a clear globe-shaped acrylic helmet with five video screens, LED lights, two interior fans, an external light with a camera; a rubber skull cap with a "Millburn" patch attached to the front; a cowl neck for the helmet to attach to with four video screens on the interior; a combination resin chest armor and backpack; a gray-blue stretch canvas jumpsuit over a layer of neoprene with rubber foam armor attached by metal rivets; a black nylon belt with metal hardware; leather and neoprene stunt gloves with elastic joints on the resin armor; and resin-armored boots. The suit's helmet and neck rig incorporate video screens with custom animations created for the costume. The chest pack also features a light-up front panel and a backpack that houses the battery pack as well as the flipswitch that activates the lights and video screens. Of the nine total video screens, one does not work in the helmet, and three of the four in the cowl neck have corrupted data and while they turn on, do not play the video. Production lightly distressed this spacesuit to appear used, and the bodysuit exhibits white residue from the attack-scene. This spacesuit exhibits mild scuffing on the armor and discoloration.

Contains electronics; see electronics notice in the Buyer's Guide.

**Estimate: \$25,000 - 50,000**





**322**  
**The Gimp's (Stephen Hibbert) Cage**  
**Pulp Fiction (1994)**

The Gimp's (Stephen Hibbert) cage from Quentin Tarantino's crime film Pulp Fiction. The Gimp slept in his cage until Maynard (Duane Whitaker) took him out after capturing Marsellus Wallace (Ving Rhames) and Butch Coolidge (Bruce Willis).

This large metal cage comes from the collection of the film's on-set dresser McPherson O. Downs. It features an open bottom and a hinged top held by a padlocked latch, though the lock is not original to production. The cage exhibits discoloration from age. Dimensions: 41.25" x 24.75" x 32" (105 cm x 63 cm x 81.5 cm)

**Estimate: \$6,000 - 12,000**



**323**  
**Red Apple Cigarette Carton**  
**Pulp Fiction (1994)**

A Red Apple cigarette carton from Quentin Tarantino's crime drama Pulp Fiction. Mia Wallace (Uma Thurman), Butch Coolidge (Bruce Willis), and Pumpkin (Tim Roth), smoked Red Apple cigarettes - a fictional brand featured in several Tarantino films - throughout the film.

This plastic-wrapped paper and foil carton featuring a label depicting a cigarette-smoking green worm protruding from a red apple comes from the collection of the film's on-set dresser McPherson O. Downs. It is intentionally distressed by production with tears and holes throughout. Dimensions: 3.25" x 2.25" x 0.75" (8.5 cm x 5.5 cm x 2 cm)

**Estimate: \$2,000 - 4,000**

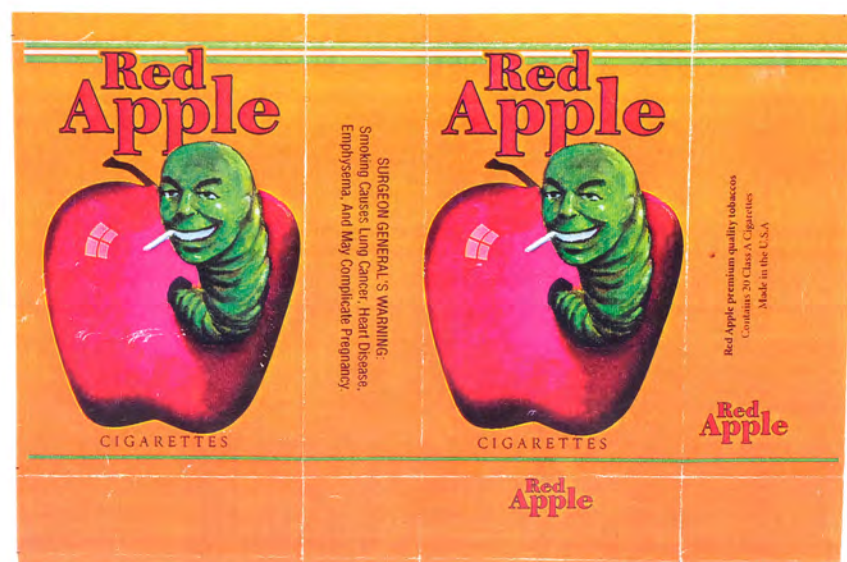

**324**  
**Production-Made Red Apple Cigarettes Wrapper**  
**Pulp Fiction (1994)**

A Red Apple Cigarettes wrapper from the production of Quentin Tarantino's crime drama Pulp Fiction. Mia Wallace (Uma Thurman), Butch Coolidge (Bruce Willis), and Pumpkin (Tim Roth), smoked Red Apple cigarettes - a fictional brand featured in several Tarantino films - throughout the film.

Created by production as a color test, his single-sided paper label depicting two cigarette-smoking green worms protruding from red apples comes from the collection of the film's on-set dresser McPherson O. Downs. It is also printed with a Surgeon General's warning and a "Made in the USA" label. The wrapper exhibits fold lines and staining from production. Dimensions: 3.5" x 2.25" (9 cm x 5.75 cm)

**Estimate: \$2,000 - 4,000**



**325**  
**Albert "Al" Calavacci's (Dean Stockwell) "A Leap for Lisa"**  
**Costume by Jean-Pierre Dorleac**  
**Quantum Leap (1989-1993)**

Albert "Al" Calavacci's (Dean Stockwell) "A Leap for Lisa" costume by Jean-Pierre Dorelac from Donald P. Bellisario's time-skipping drama series Quantum Leap. Sam Beckett (Scott Bakula) leaped into a younger version of Al to prevent the death of Al's former flame, Lt. Lisa Sherman (Terry Farrell).

Designed by Emmy®- and Academy Award®-winning costume designer Jean-Pierre Dorleac, this costume consists of a bespoke black metallic leather and raspberry suede bomber jacket with front-snap closures; a bespoke black cotton long-sleeve button-down dress shirt featuring two black iridescent chain-maille collar decorations; a red metallic polyester skinny necktie; bespoke raspberry silk pleated trousers; a red stamped snakeskin belt with a brass buckle; raspberry nylon socks; and black patent leather oxfords with steel capped toes. "DEAN STOCKWELL" hand-marks adorn the trouser waistband and shirt collar. The lot exhibits minimal edge wear, with minor scuffing and scratching on the shoes.

**Estimate: \$5,000 - 10,000**





**326**  
John Rambo's (Sylvester Stallone) Bowie Knife and Sheath  
**Rambo III (1988)**

John Rambo's (Sylvester Stallone) bowie knife and sheath from Peter MacDonald's action sequel Rambo III. After his mentor Col. Trautman (Richard Crenna) was captured by Soviet forces in Afghanistan, Rambo wielded his signature knife on a mission to free him at any cost.

Custom-made by knifemaker and designer Gil Hibben, this knife and sheath originate from Stallone's personal collection. The knife features a lightweight aluminum blade with a slit down the side, a curved resin handle painted brown to resemble wood, and a leather cord inserted through the base. The brown leather sheath features its own cord and a metal snap-button closure which is unable to close due to the size of the knife. The knife exhibits some tarnishing and peeling paint, and the leather exhibits cracking throughout from production. Dimensions: 17" x 4" x 1" (43.25 cm x 10.25 cm x 2.5 cm)

Blade was dulled by production.

**Estimate: \$8,000 - 16,000**



**327**  
John Rambo's (Sylvester Stallone) Fishing Bow and Arrow  
**Rambo (2008)**

John Rambo's (Sylvester Stallone) fishing bow and arrow from Sylvester Stallone's action film Rambo. Rambo used his bow and arrow to fish in the river.

This lot consists of a bow and one arrow. The bow features a nylon cord bow string, an attached reel of braided nylon fishing line, rubber banding, and a leather handgrip. The arrow's conical head features two prongs and attachments for the fishing line. Production intentionally distressed the bow to make it appear aged. The arrow exhibits paint chipping and scratches in the finish, and the nylon cord exhibits wear with thinned out portions. Dimensions (bow): 63.25" x 15" x 5" (160.75 cm x 38.25 cm x 12.75 cm)

**Estimate: \$4,000 - 8,000**



**328**  
Alice's (Milla Jovovich) Costume  
**Resident Evil: Apocalypse (2004)**

Alice's (Milla Jovovich) costume from Alexander Witt's action-horror sequel Resident Evil: Apocalypse. Alice wore her costume throughout the film as she guided Jill Valentine (Sienna Guillory), Carlos Olivera (Oded Fehr) and other survivors out of Raccoon City.

The costume consists of a khaki fishnet vest, an orange camisole vest (marked size small), a pair of black flared jeans and a pair of distressed black boots with buckle detailing. A label with the text "Hero Stage 1" handwritten in black is adhered to the inside of the jeans, and strips of white tape with "Alice 2nd" are stuck to the interior of the boots. There is a small rip on the front of the jeans, and some garments show minor wear from use on production. The lot is also accompanied by a production wardrobe tag which is labelled "#1 Alice".

**Estimate: \$6,000 - 12,000**



**329**  
Land of Oz Lunch Pail  
**Return To Oz (1985)**

A Land of Oz lunch pail from Walter Murch's children's fantasy sequel Return to Oz. Dorothy Gale (Fairuza Balk) and her hen Billina pulled two pails from the branches of a lunch pail tree they found soon after arriving in Oz.

This hollow vacuum-formed plastic lunch pail is hand-painted red and green to appear leafy with a brown-and-black stem and a flat base. It exhibits some paint chipping and fading from age, as well as splitting down the middle where two pieces of plastic were affixed together. Dimensions: 10" x 6" x 6" (25.5 cm x 15.25 cm x 15.25 cm)

**Estimate: \$4,000 - 8,000**



**330**  
Nome King's (Nicol Williamson)  
Bear's Head Cup  
**Return To Oz (1985)**

A Nome King's (Nicol Williamson) bear's head cup from Walter Murch's children's fantasy sequel Return To Oz. The Nome King provided Dorothy Gale (Fairuza Balk) and her companions with an assortment of limestone pies and hot melted silver served in cups with sculpted animals' heads, though this style cup did not ultimately appear in the final cut.

This silver-color metal cup features smooth tapered sides and an ornately detailed bear's head sculpted upside-down into the base to act as a stand. The metal exhibits some tarnishing from age and exposure, and the rim exhibits paint flaking from production use. Dimensions: 5" x 3" x 3" (7.75 cm x 7.75 cm x 12.75 cm)

**Estimate: \$4,000 - 8,000**



**331**  
 Joel Goodsen's (Tom Cruise) Screen-Matched Sweater Δ  
**Risky Business (1983)**

Joel Goodsen's (Tom Cruise) screen-matched sweater from Paul Brickman's comedy-drama film Risky Business. The imperfections in speckled design along the collar screen-match this sweater to the one Goodsen wore during dinner with Lana (Rebecca De Mornay).

This navy wool sweater (size L) features various speckles throughout in yellow, pink, light blue, green, and orange. The sweater exhibits holes on the front from production use.

**Estimate: \$15,000 - 30,000**



**332**  
 Robin Hood's (Kevin Costner) Screen-Matched Tunic  
**Robin Hood: Prince Of Thieves (1991)**

Robin Hood's (Kevin Costner) screen-matched tunic from Kevin Reynolds' action-adventure Robin Hood: Prince of Thieves. Robin wore his costume throughout the film as he and his fellow outlaws as they fought the corrupt and villainous Sheriff of Nottingham (Alan Rickman). Imperfection on the metal studs and thread placements match this tunic to the one seen on screen as Robin rallies the outlaws to fight back against the sheriff's tyrannical rule.

Custom-made for production, the tunic has a light purple linen body with a square neckline, a leather tie closure at the front, and separated sleeves attached to the body by leather cords. The sleeves are made from beige corduroy and feature leather detailing, fabric panels, and metal studs. An "Angels costumers" label is sewn to the interior with a handwritten note that reads "Robin O' Robe SEPT 90." The tunic exhibits intentional distressing and fraying to appear aged and well-worn and some of the studs have fallen off from production use.

**Estimate: \$5,000 - 10,000**



**333**  
 RoboCop's (Joel Kinnaman) Light-Up  
 TSR-66 Taser Pistol  
**Robocop (2014)**

RoboCop's (Joel Kinnaman) light-up TSR-66 taser pistol from Jose Padilha's sci-fi action remake RoboCop. RoboCop's primary sidearm, the TSR-66, was a cartridge-driven taser pistol that fired projectiles capable of releasing up to 200,000 volts.

This lot consists of one static rubber weapon modeled off a Beretta pistol that had a custom shell. Finished in matte black with gray side vents, it features the OmniCorp Weapons Division logo engraved on the barrel. A red light-up meter is activated by a switch under the barrel. This pistol exhibits some pitting, seam imperfections from curing, and notable paint marks. Dimensions: 13" x 7.5" x 1.75" (33.25 cm x 19.25 cm x 4.25 cm)

Contains electronic components; see notice in the Buyer's Guide.

Ownership may be restricted in some countries; see replica firearm notice in Buyer's Guide.

**Estimate: \$4,000 - 8,000**



**334**  
 Robocop Promotional Costume  
**Robocop 2 (1990)**

A Robocop promotional costume from Irvin Kershner's sci-fi-action film RoboCop 2. RoboCop (Peter Weller) wore its costume as it protected the streets of Detroit and when it went against a new evil RoboCop.

Refurbished and refabricated by roboteam painter Danny Alvarado as a promotional suit, this costume consists of iridescent purple and blue fiberglass and urethane chest armor, leg coverings, boots, arm guards, a helmet with a black vellum visor with black foam padding throughout, black rubber gloves, all on a display mannequin mounted to a black-painted metal base. The lot exhibits a loose visor and a distressed left leg covering. Dimensions: 22" x 10" x 72" (56 cm x 25.5 cm x 183 cm)

Special shipping required; see notice in the Buyer's Guide.

**Estimate: \$6,000 - 12,000**

### 335 Al Pacino's Personal Hand-annotated Shooting Script Scarface (1983)

Al Pacino's personal, hand-annotated shooting script from the production of Brian De Palma's crime drama Scarface. Pacino played Cuban immigrant Tony Montana, who made his way up the Miami crime scene to become a powerful drug lord. This script was originally gifted by Pacino to an assistant at his production company, Chal Productions.

The 158-page script, credited to Oliver Stone, is labeled "Third Draft" and is bound with metal fasteners between a black card cover. "Scarface" is embossed in gold-color lettering on the cover. Several pages feature annotations in Pacino's handwriting, including line changes and phonetic spellings so he could perfect his Cuban accent. Page 157 features the iconic "Say hello to my little friend!" line.

The script is accompanied by a picture of Pacino as Tony Montana and a scrap of paper with a handwritten note, both of which are tucked within the pages. Some of the pages, most notably at the front of the script, exhibit stains, while others exhibit minor tears. Dimensions: 11.5" x 9" x 0.75" (29.5 cm x 22.5 cm x 2 cm)

Estimate: \$40,000 - 80,000



Third Draft  
Martin Bregman Productions  
Property Universal Pictures

NTD 83.  
ELVIRA  
Never mind what a woman like me should or shouldn't do. It's none of your business is it?  
TONY  
Me I been down in Bolivia and Panama  
ELVIRA  
Broadening your intellect. I heard.  
TONY  
Yeah. What else did you hear?  
ELVIRA  
I heard you and Frank aren't working together anymore.  
TONY  
Yeah. It makes things easier this way, don't it?  
Drinks a toast.  
TONY  
Here's to the land of opportunity  
She drinks to it, increasingly puzzled.  
TONY  
Say, do you like kids?  
ELVIRA  
Kids? Sure, why not.  
TONY  
Good. Cause I like kids too. I like boys and girls.  
She's waiting. He paws the ground as awkwardly as a bull.  
TONY  
Look, here's what I am. I'm from the gutter but I climbed out of it. I'm not the smartest guy in the world but I got guts and I know the streets and I'm making the right connection. With the right woman, there's no stopping me. I could go to the top, I could be somebody here in Miami, somebody important to the community. Like Frank y'know, charities, committees but biggest. The biggest. Tony Montana. Immigrant refugee makes good. That's me. Okay?

*with the  
right woman  
who know?*

4 CONTD  
TONY  
Yeah, with whose cock honey? Yours or mine?  
TRANSEVESTITA (reverting to Spanish)  
You probably love to take it, you closet fag.  
TONY (calling after her in Spanish)  
The size of yours, I'd be lucky to feel it.  
MANNY interjects.  
TONY  
Whatcha hanging around with that creep for?  
MANNY  
Hey he's okay, he hears things  
TONY  
What's he hear that I don't hear  
MANNY  
He hears we got problems. Immigration is having these "conclusionary hearings" y'know? And they're saying 9 out of 10 of us is bad news. So they're gonna ship us back.  
Oh yeah?  
TONY  
Yeah. And a lotta shit just went down at Indianown Gap y'know? In Pennsylvania. Riots, fires... things are gonna pop here  
TONY  
Shit, I coulda told you that  
MANNY  
Yeah, so what do you think the Federales are gonna do if we riot? You think they're gonna let us out. Shit they're gonna throw the key away that's what.  
TONY  
Hey Manny, this is America, they got lawyers here. Castro don't want us back, hey nobody nowhere wants us, so what are they gonna do with us, put us in a gaschamber? They're stuck with us, okay.  
MANNY  
Yeah, well what if we gotta sit here another six months.

11.  
1 CONTD  
Common-est  
MAN 1 (checking off a list)  
You been in a mental hospital Tony?...  
a crazy house?  
TONY (laughs)  
Crazy? Me? You joking?  
MAN 1  
How 'bout homosexuality Tony. You like men, y'like to dress up like a woman...?  
TONY (reverts to Spanish, to MAN 2)  
What the fuck's wrong with him man, he sick or what?  
MAN 2 (Spanish)  
Just answer the questions okay?  
TONY (to MAN 1)  
Fuck no. Okay.  
MAN 1  
Arrested? Vagrancy? Marijuana? Anything?  
TONY  
No...No. Never. Nothing.  
MAN 1  
Regular little Red Riding hood huh?  
These Martielitos are good.  
MAN 2 steps forward out of the shadows, squat like a football coach.  
MAN 3  
So where'd you get the beauty scar asshole, eating pussy?  
(they laugh)  
TONY  
What? This?...  
(touches his scar, shrugs)  
I was in this fight. When I was a kid. You should see the other guy.  
(laughs)  
MAN 3  
And this?  
He holds up TONY'S hand and indicates the tattoo between his thumb and second finger -- a heart with the word "Madre" written through it.  
TONY  
Oh that's for my sweetheart.

*Common-est*  
You been in a ment  
a crazy house?  
zy? Me?

The SKULL blown to bits.  
TONY throws away the spent machine gun, pulls a pistol, looks up the stairs -- knowing the only chance he has is to get up those stairs.  
He's hit again. He stumbles for the stairs, covering himself, keeping HITTERS FOUR and FIVE pinned in the LIVING ROOM.  
TONY moving up the stairs, firing out the last of his clip.  
TONY  
COME ON! FUCK YOU YOU SCUMBAGS! COME ON!  
HITTERS SIX and SEVEN darting through the OFFICE from the other side of the FOYER, open fire on TONY.  
TONY is hit again in the leg, crumples halfway up the stairs. Another GRENADE is tossed up the stairs, explodes short of TONY.  
The CHANDELIER suddenly comes unhinged from the concussion and crashes down onto the FOYER FLOOR.  
TONY takes advantage of the distraction to stagger up the remaining STAIRS.  
180 INTERIOR TONY'S BEDROOM 190  
He hobbles into his huge BEDROOM, crosses to a cabinet, and breaks out a shoulder-fired ROCKET LAUNCHER with refill-rounds, talking to himself the whole time.  
TONY  
You think you can kill me with one lousy bomb...who do you think I am...I kill all you fucking assholes...I blow you all to fucking hell!  
191 INTERIOR TONY'S HALLWAY/LIVING ROOM 191  
He hurries out into the hall. He's almost hit. They're down there at the other end firing.  
TONY  
COME ON YOU SCUM HERE I AM, SAY HELLO TO MY LITTLE FRIEND HERE!  
He fires the ROCKET.  
It sounds like Armageddon when it hits...One of the HITTERS is screaming, smoke is billowing wildly.  
TONY hurries up the stairs, reloading.  
A FIGURE crows through the smoke, fires his machine gun.

12.  
1 CONTD  
MAN 3  
Sweetheart huh? My ass...  
MAN 1 and MAN 2 have come forward to study it.  
MAN 3 (to them)  
It's some kinda code these guys use in the can. I never seen this one before.  
(to TONY)  
You want to tell us asshole or you want to tell 'em up at Fort Chaffee?  
TONY  
So I was in for buying dollars, big deal...  
MAN 2 laughs.  
MAN 2  
That's funny, that's good.  
TONY  
...is true, I get them from Canadian tourist.  
MAN 3  
What'd you do, mug his first? Get him outta here!  
TONY  
Hey, so I fuck Castro, so what's it to you huh? What would you do, they tell you all the time what to think, what to feel, what to say? Fuck! You gonna work eight hours a day and you never own nothing? I ate fucking octopus three times a day, octopus was coming out my ears! Whaddya think I am? I'm no little puts of a chest! I'm Tony Montana and I am a political prisoner here from Cuba and I want my fucking "Mama Rights" just like President Jimmy Carter says, okay?  
Pause. The look on MAN 3's face is disbelieving. The other TWO chuckle.  
MAN 2  
Carter should see this human right. He's good, very good.  
They chuckle except for MAN 3 who shakes his head, walking out.

*Canadian  
Fucking go to  
ng unless  
t? Get him  
followed by  
a do -  
tell you  
to feel,  
everybody  
eight*



**336**  
 Documentary Footage-Matched Exploded Billy the Puppet Head  
**Saw IV (2007)**

An exploded Billy the Puppet head from Darren Lynn Bousman's horror sequel Saw IV. In the film, a Billy puppet exploded after Agent Perez (Athena Karkanis) found it in an office. This puppet screen-matches to footage from the making of the sequence in the behind-the-scenes documentary The Props of Saw IV, though a different version of the puppet ultimately appeared in the Saw IV final cut.

This resin and metal puppet head features internal machinery, a metal tube neck, an articulate jaw, and wefts of glued-down black synthetic hair. This lot exhibits some notable paint marks, exposed wires, and chipped paint. Dimensions: 17" x 8" x 7" (43.25 cm x 20.5 cm x 18 cm)

Contains mechanical components; see notice in the Buyer's Guide.

**Estimate: \$4,000 - 8,000**



**337**  
 Ghostface Mask  
**Scream 2 (1997)**

A Ghostface mask from Wes Craven's slasher sequel Scream 2. A new Ghostface killer donned their iconic mask to terrorize Sidney Prescott (Neve Campbell) and her peers at Windsor College.

This lot consists of a white face mask made of soft PVC with a blackened mouth and nose, black mesh inside the eyes, "Easter Unlimited, Inc." and "Made in China (MK)" debossed on the backside of the long chin, and a black cotton shroud with a fastening strip on top. It exhibits yellow staining and the shroud has loose threads.

**Estimate: \$12,000 - 24,000**



**338**  
 Wes Craven and Chris Durand-Autographed Ghostface Robe  
**Scream 2 (1997)**

A Ghostface robe from Wes Craven's slasher sequel Scream 2 that has been autographed by director Wes Craven and Chris Durand, one of the actors/stuntmen to portray the costumed Ghostface in the film. A new Ghostface killer donned their iconic costume to terrorize Sidney Prescott (Neve Campbell) and her peers at Windsor College.

This lot consists of a black cotton lurex hooded robe featuring attached gloves, long-sleeve fringes with rounded tips, foam sewn into the hood to help it maintain shape, fastening strips in the hood and along the front opening, and cuts along the bottom. It has been signed in silver-color ink on the inside by Wes Craven and Chris Durand. It exhibits some wear from use, including frayed threads and staining.

**Estimate: \$5,000 - 10,000**



**339**  
 Ghostface Knife  
**Scream 2 (1997)**

A Ghostface knife from Wes Craven's slasher sequel Scream 2. A new Ghostface killer terrorized Sidney Prescott (Neve Campbell) and her peers at Windsor College using their signature Buck 120 knife.

This lot consists of a metal Buck 120 knife with a black handle and a black leather Buck sheath with metal snaps. The metal knife has scratches throughout from use and age, and the blade was dulled by production. Dimensions: 12.5" x 2.25" x 1.5" (31.75 cm x 5.5 cm x 4 cm)

**Estimate: \$8,000 - 16,000**



**340**  
Jayne Cobb's (Adam Baldwin)  
Costume with Screen-Matched  
Jacket  
**Serenity (2005)**

Jayne Cobb's (Adam Baldwin) costume with screen-matched jacket from Joss Whedon's sci-fi adventure film Serenity. Cobb wore his costume when he and the crew attempted a heist, and when escaping from Reavers.

This lot consists of a faded blue fabric graphic T-shirt with a screen-printed graphic on the chest marked "Jayne Hero" on the collar; a green zipper jacket purposely distressed by production to appear battle worn labeled "Jayne Hero Non Harpoon"; a light green cargo pants labeled "Jayne Hero Non Harpoon"; a black leather ammo belt with a brown leather knife sheath, ammunition holders with three stunt magazine clips decorated with various small metal charms and trophies Jayne likely gathered from his victims over the years; an additional brown leather belt with brass-color metal studs; a black leather double-buckle wristband; fingerless leather gloves; a shoulder sash complete with a metal buckle for securing the stunt rubber Heckler and Koch MP5K; and one original wardrobe tag from production. The jacket is screen-matched not only to the heist scene, due to two upper right shoulder holes matching from heist, but also also to the Reaver escape scenes: both the right cuff cut-edging and rim blackened weathering matches, and the back left hem distressing/discoloration pattern also matches from when Jayne hangs off the back of the Flying Mule. The costume shows minor wear due to production use and charms falling off the belt.

**Estimate: \$8,000 - 16,000**



**341**  
Marilyn Monroe Silver Gelatin Print  
- George Barris  
**The Seven Year Itch (1955)**

A George Barris portrait of Marilyn Monroe from the production of Billy Wilder's romantic comedy The Seven Year Itch. An acclaimed photojournalist, Barris photographed Monroe on the set of the film. He took several later portraits of the troubled star, becoming her confidant in the final weeks of her life.

This photograph was taken in September 1954 on the corner of New York's Lexington Avenue and 52nd Street. It captures Monroe as she posed for photographers in her famous billowing white dress during the filming of the subway grate scene.

The black-and-white portrait is printed on silver gelatin and displayed in a cream-color cardboard photo mount. Barris' signature appears on the bottom right. Dimensions: 19.75" x 15.75" x 0.25" (50 cm x 40 cm x 0.5 cm)

Sold without copyright; see copyright notice in the Buyer's Guide.

**Estimate: \$8,000 - 16,000**

**342**  
Andy Dufresne's (Tim Robbins)  
State of Maine Letter and Check  
**The Shawshank Redemption (1994)**

Andy Dufresne's (Tim Robbins) State of Maine letter and check from Frank Darabont's prison drama The Shawshank Redemption. Maine awarded Dufresne funds to refurbish Shawshank State Penitentiary's library.

This lot originated with a crew member. It consists of a black-and-white typewritten letter dated "July 21, 1955" from "State Controller J.H. McAlahney" to "Mr. Dufresne," and a \$200 check with the same date made out from the "First Bank of Maine" to "Shawshank State Prison." The letter exhibits fold lines, and the check's edges exhibit tearing. Dimensions (letter): 8.5" x 11" (21.75 cm x 28 cm); (check): 3.5" x 7.5" (9 cm x 19.25 cm)

**Estimate: \$2,000 - 4,000**

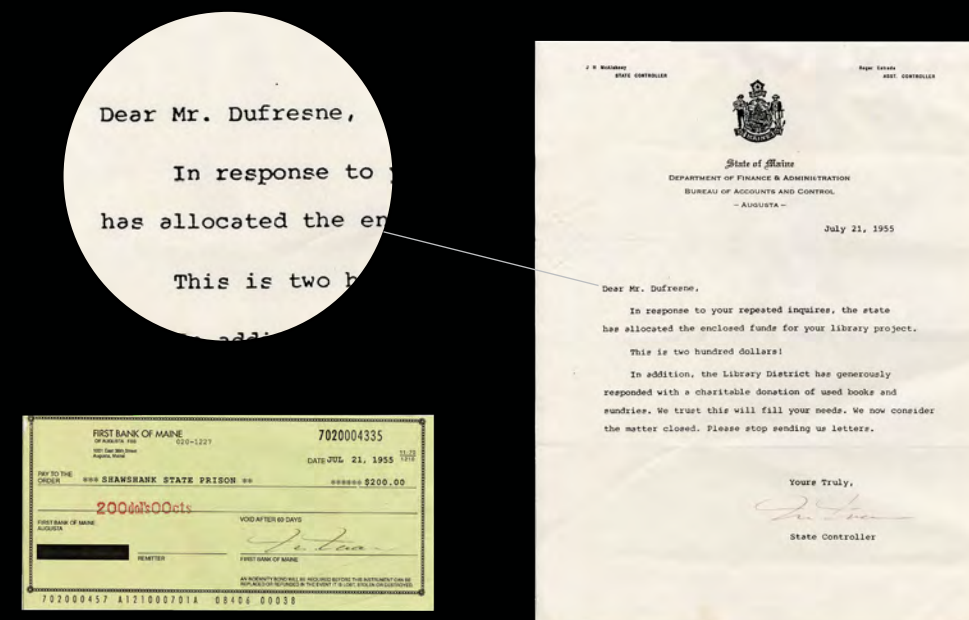

**343**  
Andy Dufresne's (Tim Robbins)  
Screen-Matched Record Player  
**The Shawshank Redemption (1994)**

Andy Dufresne's (Tim Robbins) record player from Frank Darabont's prison drama The Shawshank Redemption. This record player screen-matches to the scene in which Dufresne played an Italian opera for his fellow inmates from the warden's (Bob Gunton) office.

This vintage brown tweed and yellow striped Meissner portable phono-recorder record player and suitcase with model no. 9-1065 originated from Darabont's personal collection. Designed to play records and the radio as well as record sound, it features a compartment on the fully removable top lid, and "Portland Public School District" stenciled in black ink on the top. The player remains functional with frayed fibers, discoloration, scratches, and missing screws. Dimensions: 19.5" x 19.75" x 9.5" (49.75 cm x 50.25 cm x 24.25 cm)

Contains electronics; see electronics notice in the Buyer's Guide.

Contains mechanical components; see notice in the Buyer's Guide.

**Estimate: \$15,000 - 30,000**



**344**

**Andy Dufresne's (Tim Robbins) Distressed Rock Hammer**

**The Shawshank Redemption (1994)**

Andy Dufresne's (Tim Robbins) distressed rock hammer from Frank Darabont's prison drama The Shawshank Redemption. Dufresne used his rock hammer to dig a secret tunnel out of Shawshank State Prison.

The Shawshank Redemption, adapted from Stephen King's novella of a similar title, saw great success in the home-video market with Warner Home Video shipping over 320,000 copies throughout the United States in 1995, allowing it to become the seventh top rental of that year. It was inducted into the United States Library of Congress' National Film Registry as a culturally significant work in 2015, and is featured on numerous top film lists from not only the American Film Institute but also numerous media outlets, including Rolling Stone and USA Today.

Three styles of rock hammer were created for the film, with increasingly damaged bodies and shortened heads designed to reflect various amounts of use over Dufresne's 20-year imprisonment. This steel and wood version representing the second-oldest style originated from Darabont's personal collection.

To appear used, its head is intentionally dulled and scratched by production with some discoloration applied around the top of the handle. The hammer exhibits some shifting to its rivets and minor chips to the wood. Dimensions: 8" x 8" x 2" (20.5 cm x 20.5 cm x 5 cm)

**Estimate: \$50,000 - 100,000**



Album / Alamy Stock Photo



**345**

Warden Norton's (Bob Gunton)  
Screen-Matched Framed Sampler  
**The Shawshank Redemption**  
**(1994)**

Warden Norton's (Bob Gunton) screen-matched framed sampler from Frank Darabont's prison drama *The Shawshank Redemption*. This sampler screen-matches to the one Norton's wife cross-stitched in her church group and Norton then mounted above the safe he filled with corrupt funds, taking it down only after Andy Dufresne (Tim Robbins) exposed him.

*The Shawshank Redemption*, adapted from Stephen King's novella of a similar title, saw great success in the home-video market with Warner Home Video shipping over 320,000 copies throughout the United States in 1995, allowing it to become the seventh top rental of that year. It was inducted into the United States Library of Congress' National Film Registry as a culturally significant work in 2015, and is featured on numerous top film lists from not only the American Film Institute but also numerous media outlets, including *Rolling Stone* and *USA Today*.

This cream-color canvas sampler originated from Darabont's personal collection. Originally hand-crafted for the production by a needlepoint artist in Mansfield, OH, where the film was shot, the sampler reads "His Judgment Cometh and That Right Soon.." in maroon thread with green and red borders surrounding it. It comes mounted behind glass in a black wooden frame with a sticker from the Ben Franklin Frame Shop, also of Mansfield, applied beneath a metal hanging wire on the reverse.

The frame exhibits minor scuffs along its edges, and its brown paper backing is torn in several places from handling, exposing the canvas. Dimensions: 20" x 31" x 2" (51 cm x 78.75 cm x 5 cm)

**Estimate: \$40,000 - 80,000**

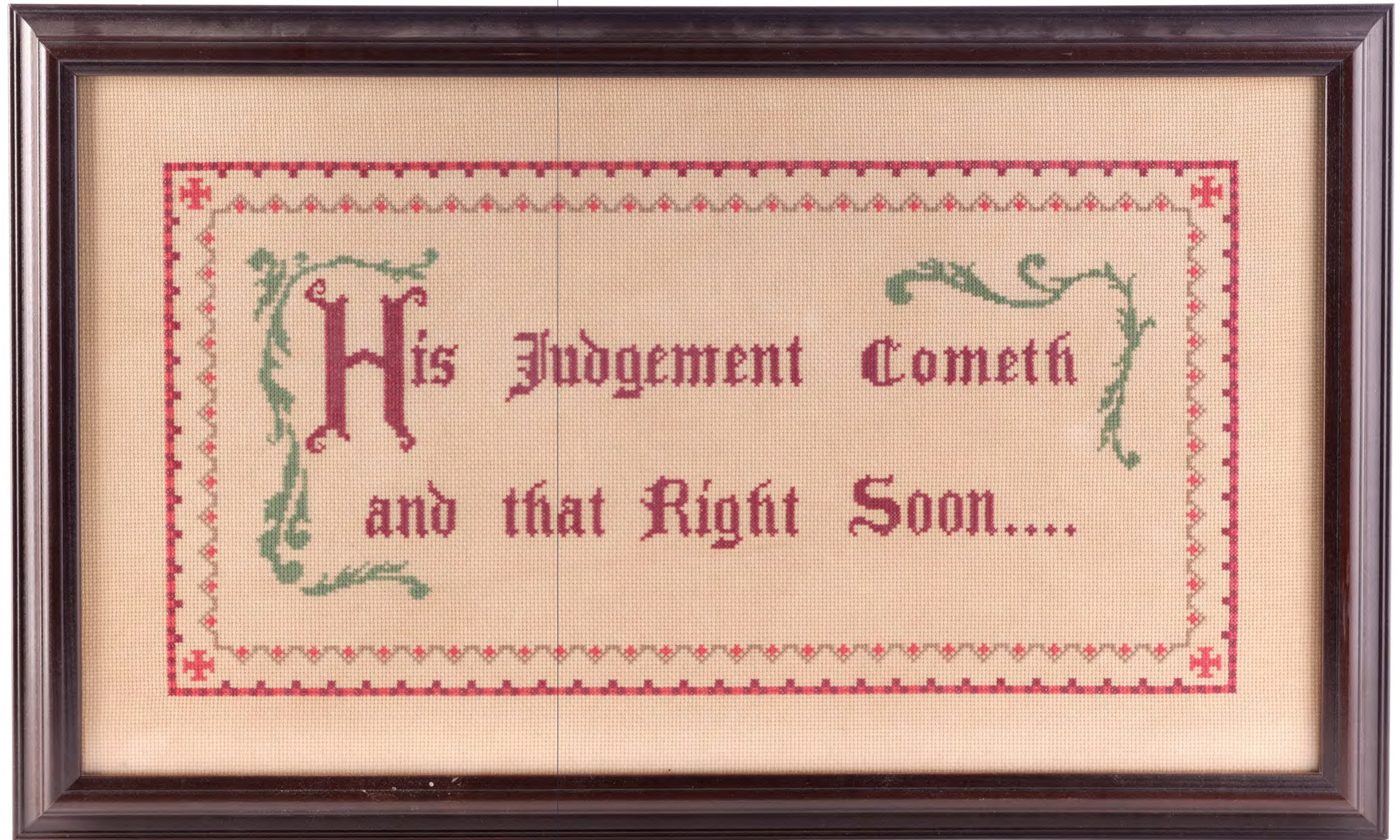

**346**  
 Ellis Boyd 'Red' Redding's  
 (Morgan Freeman)  
 Screen-Matched Costume  
**The Shawshank Redemption**  
 (1994)

Ellis Boyd 'Red' Redding's (Morgan Freeman) screen-matched costume from Frank Darabont's prison drama *The Shawshank Redemption*. Redding wore his costume, the facility's standard prison uniform, while incarcerated at Shawshank State Prison. This costume screen-matches to several scenes.

This lot consists of a blue and white striped long-sleeve, button-up cotton shirt hand-marked "Red #2" with black buttons, a "W.C.C." (Western Costume Company) stamp, and a patch above the left breast pocket stenciled with the number "30265"; and faded blue denim trousers hand-marked "Red #4" on the inside with a Western Costume Co. stamp. In addition to production-applied aging, the costume exhibits some yellowing, staining, and pulled threads.

**Estimate: \$25,000 - 50,000**



Maximum Film / Alamy Stock Photo

**347**  
 Andy Dufresne's (Tim Robbins)  
 Screen-Matched Costume  
**The Shawshank Redemption**  
 (1994)

Andy Dufresne's (Tim Robbins) screen-matched costume from Frank Darabont's prison drama *The Shawshank Redemption*. Dufresne wore his costume, the facility's standard prison uniform, while incarcerated at Shawshank State Prison. This costume screen-matches to several scenes.

This lot consists of a blue and white striped long-sleeve, button-up cotton shirt marked "Andy 3" with black buttons, a "W.C.C." (Western Costume Company) stamp, a patch above the left breast pocket stenciled with the number "37927," and a paper tag labeled "17 36 #54"; and blue denim trousers hand-marked "Andy DBL" on the inside with a Western Costume Co. stamp. In addition to production-applied aging, the costume exhibits some yellowing, staining, and pulled threads.

**Estimate: \$25,000 - 50,000**



Maximum Film / Alamy Stock Photo



**348**  
 Rev. Graham Hess' (Mel Gibson)  
 Mirrored Knife  
**Signs (2002)**

Rev. Graham Hess' (Mel Gibson) mirrored knife from M. Night Shyamalan's sci-fi horror film Signs. Hess used the reflection in his kitchen knife to look under his pantry door, then chopped an alien's fingers with it.

This large metal knife was custom-made with reflective metals for the production. It features a black urethane handle and a cloth sheath labeled "mirrored knife keep in sheath fragile" with tape. The sheath exhibits staining and the blade exhibits scratching from production. Dimensions: 17" x 2.25" x 1" (43.25 cm x 5.75 cm x 2.5 cm)

The blade was dulled by production.

**Estimate: \$7,000 - 14,000**



**349**  
 Light-up Blue Beetle (Jaren Brandt  
 Bartlett) Costume UK  
**Smallville (2001-2011)**

A light-up Blue Beetle's (Jaren Brandt Bartlett) costume from the superhero series Smallville. In the season 10 episode "Booster" teenager Jaime Reyes (Bartlett) becomes the host of alien technology in the form of a blue beetle.

The costume includes a fiberglass helmet with light-up eyes and a detachable faceplate; fiberglass foam-lined pauldrons; a fiberglass and rubber right-hand gauntlet; and a foam-lined fiberglass breastplate fixed together with metal plates and screws and featuring mandibles on the shoulders, a rear shell design, and insect-leg detailing around the chest. The helmet eyes light up when powered with a 9V battery. Each piece is airbrushed in royal blue and dark gray, and exhibits minor paint wear on the edges and breastplate-joining panels.

Contains electronics; see electronics notice in the Buyer's Guide.

**Estimate: \$5,000 - 10,000**

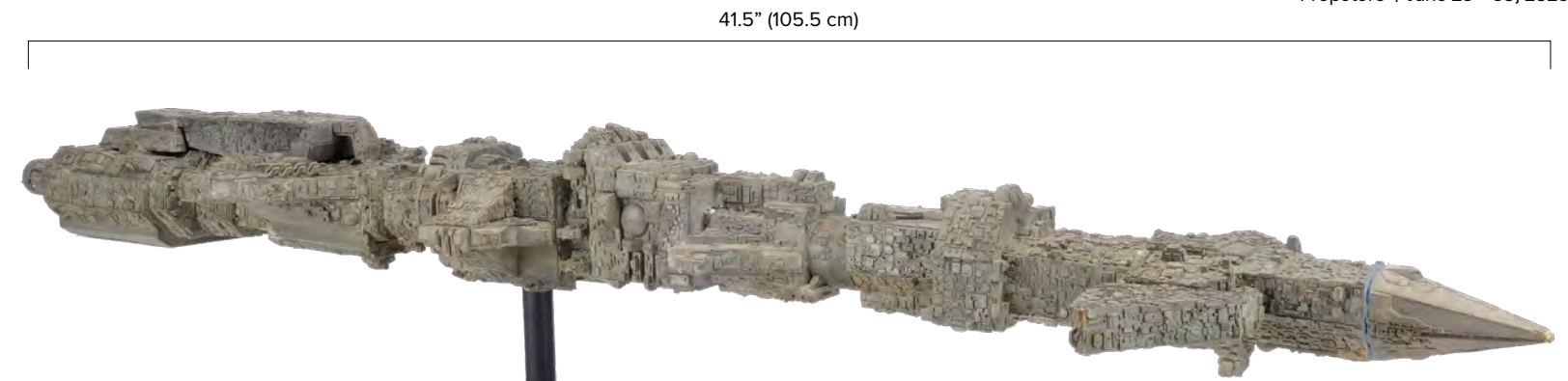

41.5" (105.5 cm)



**350**  
 Light-Up Spaceball One (Mothership) Model Miniature Display  
**Spaceballs (1987)**

A light-up Spaceball One (mothership) model miniature display from Mel Brooks' sci-fi comedy Spaceballs. Spaceball One, Dark Helmet's (Rick Moranis) mothership, housed the residents of Spaceball ruled by President Skroob (Mel Brooks).

Apogee built two Spaceball One models based on the Tantive IV from Star Wars: A New Hope for the production: a massive 17' version, and this smaller version created for wide shots, such as when the mothership blasts into the distance. It is constructed of styrene and resin, detailed with kit-bashed model parts and cast greeblies, painted industrial gray, and installed throughout with fiber optic lighting which illuminates via a button on the base. Also included is a detachable "vacuum cleaner" top section for the scene in which Spaceball One transforms into Megamaid.

This model comes mounted via a metal rod to a black wooden display with a light-up "Spaceballs" logo. As it exhibits various notable points of repairs made in sections as well as chipping materials, it should be handled with care. Dimensions: 41.5" x 7.5" x 4" (105.5 cm x 19 cm x 10.25 cm)

Contains electronics; see electronics notice in the Buyer's Guide.

**Estimate: \$10,000 - 20,000**



**351**  
 Trooper Helmet and Rifle  
**Spaceballs (1987)**

A trooper helmet and rifle from Mel Brooks' adventure-comedy Spaceballs. Troopers aboard the Spaceball 1 wore helmets and wielded rifles as Lonestar (Bill Pullman) infiltrated and escaped the ship.

This lot consists of a white-painted, vacuum-formed sphere plastic helmet with a yellow plastic stabilizing liner and a black nylon chin strap marked "C" and "12W"; a silver-color painted rubber rifle molded from a Calico M-100, and a black nylon shoulder strap. This lot exhibits cracks and restoration to the helmet and fading paint on the rifle. Dimensions: 27.5" x 8" x 1.75" (70 cm x 20.5 cm x 4.5 cm)

**Estimate: \$3,000 - 6,000**

**352**  
 Spider-Man's (Nicholas Hammond) Costume with  
 Web-Shooter  
**Spider-Man (1977-1979)**

Spider-Man's (Nicholas Hammond) costume with a web-shooter from the action-adventure series Spider-Man. Spider-Man wore his costume and web-shooter as he protected local citizens throughout the series.

This lot consists of a red and blue elastane bodysuit marked "2-17-77 N. Hammond" with a black web design throughout, black and red spider patches on the front and back, red leather soles, and gray painted plastic eye lenses with holes; a metal web-shooter wristband; a red leather belt with silver-color painted wood blocks and a metal Spider-Man belt buckle; and a black leather bracelet with silver-color painted wood blocks. This lot exhibits worn material and a broken back zipper.

**Estimate: \$15,000 - 30,000**



**353**  
 Framed Hand-Painted  
 Greg Hildebrandt Avengers  
 #16 Cover Artwork  
**Marvel Comics**

Framed cover artwork hand-painted by Greg Hildebrandt for Marvel Comics' Avengers #16. Hildebrandt painted the piece as a variant cover for the issue, which was published by Marvel Comics in 2019.

This artwork depicting Spider-Man battling the Green Goblin in front of the Washington Square Arch against a moonlit sky is rendered in acrylic paint on canvas and signed by Hildebrandt in the lower right corner. It comes mounted behind glass in a custom-made frame. Dimensions (framed): 31" x 43" x 1" (78.75 cm x 109.25 cm x 2.75)

Sold without copyright; see notice in the Buyer's Guide.

Stored off-site; see off-site storage notice in the Buyer's Guide.

**Estimate: \$10,000 - 20,000**



**354**  
Production-Made Green Goblin (Willem Dafoe) Helmet  
**Spider-Man (2002)**

A Green Goblin (Willem Dafoe) helmet from the production of Sam Raimi's sci-fi film Spider-Man. Deranged industrialist Norman Osborne wore his signature helmet while battling his arch nemesis, Spider-Man (Tobey Maguire), as the armored villain Green Goblin.

Constructed of metallic green-painted resin and aluminum metal teeth, this production-made helmet was created by the Academy Award-winning special effects group Amalgamated Dynamics, Inc. (ADI). This lot exhibits extensive repair on the interior with polyester putty. Dimensions: 20" x 8.5" x 6.5" (51 cm x 21.75 cm x 16.5 cm)

**Estimate: \$8,000 - 16,000**



**355**  
Starfleet Utility Jumpsuit  
**Star Trek: The Motion Picture (1979)**

A Starfleet utility jumpsuit from Robert Wise's sci-fi film Star Trek: The Motion Picture. Starfleet officers wore uniforms while on duty.

This costume consists of an olive-green poly-blend jumpsuit and matching shoes with eyelets to attach the trousers. A metal Starfleet insignia badge, white shoulder epaulets, and a black resin life support monitor are attached to the jumpsuit. It features an interior tag hand-marked for "8 Women," and the shoes are hand-marked "7 1/2." Also included is a production tag hand-marked for "Paramount 'Star Trek' Fatigue Jumpsuit Size 8 Long." This lot exhibits notable water damage on the production tag and some discoloration on the jumpsuit.

**Estimate: \$3,000 - 6,000**



**356**  
Spock's (Leonard Nimoy)  
Sick Bay Costume  
**Star Trek: The Motion Picture (1979)**

Spock's (Leonard Nimoy) sick bay costume from Robert Wise's sci-fi film Star Trek: The Motion Picture. Spock wore his costume while recovering in the Enterprise sick bay from his mind meld with V'ger, a sentient alien ship.

This costume consists of an off-white fleece hooded sleeveless jacket with an orange interior and Western Costume Co. tag labeled "2239-1 Leonard Nimoy 41," as well as a pair of matching pants labeled "2239-1 Leonard Nimoy 30 1/2." Both garments feature clear rubber piping trim affixed with fastening strips and the jacket features two silver-color plastic covers over the chest. The costume exhibits discoloration from age and a hole in the pants' inseam.

**Estimate: \$15,000 - 30,000**





**357**  
Starfleet Officer's Security Division Uniform  
**Star Trek: The Motion Picture (1979)**

A Starfleet officer's Security division uniform from Robert Wise's sci-fi film *Star Trek: The Motion Picture*. Starfleet officers of the Security division wore uniforms while on duty. This uniform consists of a gray poly-blend, long-sleeve tunic and a pair of double pleated gray poly-blend pants. A gray Starfleet insignia patch is sewn onto the chest, and a black resin life support monitor belt buckle is attached to the front of the uniform on a short belt. The tunic features a tag marked "Phil Weyland" and number "2395 I." The pants feature a tag marked for "Bobby Butz" and number "2238 I." Also included is an 8" x 10" color photo of the cast and one production tag. This lot exhibits discoloration and stretched and loosened threads at the seams.

**Estimate: \$4,000 - 8,000**

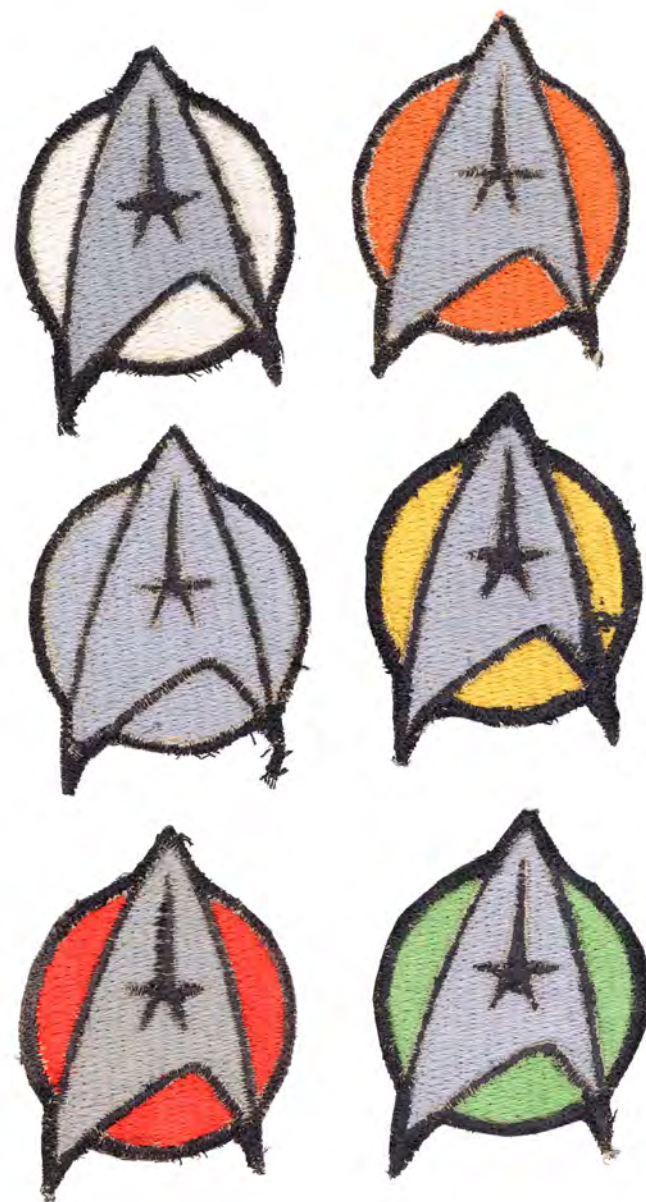

**358**  
Set of Starfleet Uniform Insignia Patches  
**Star Trek: The Motion Picture (1979)**

A set of Starfleet uniform insignia patches from Robert Wise's adventure-sci-fi film *Star Trek: The Motion Picture*. USS Enterprise crew members wore Starfleet insignia patches on their uniforms throughout the film.

This lot consists of felt embroidered patches in various colors: seven full gray patches; seven gray and yellow patches; seven orange and gray patches; six white and gray patches; nine red and gray patches; and six green and gray patches. These patches exhibit loose threads and minor grime from age. Dimensions: (each) 1.75" x 2.25" (4.5 cm x 5.75 cm)

**Estimate: \$8,000 - 16,000**



**359**  
Admiral James T. Kirk's  
(William Shatner) Romulan Ale  
Bottle Birthday Gift  
**Star Trek II: The Wrath Of Khan  
(1982)**

Admiral James T. Kirk's (William Shatner) Romulan ale bottle birthday gift from Nicholas Meyer's *Star Trek II: The Wrath of Khan*. Leonard McCoy (DeForest Kelley) gifted Kirk the illegal libation with the aphorism "Beware of Romulans bearing gifts."

The empty acrylic cylindrical bottle features a graduated ringed cone top with separate acrylic cork and a tiered ringed base; clear-backed gold-color printed decals with a large Romulan iconographic logo and a smaller printed "VINTAGE 2283"; and hand-etched "MP KC309" at bottom. The lot exhibits missing decal sections, acrylic glue cracking, scratching, scuffing, and dried liquid residue. Dimensions: 10" x 4" x 4" (25.5 cm x 10.25 cm x 10.25 cm)

**Estimate: \$4,000 - 8,000**

48" (122 cm)



**360**  
Regula I Docking Bay Model Miniature Component  
**Star Trek II: The Wrath Of Khan (1982)**

A Regula 1 docking bay model miniature component from Nicholas Meyer's sci-fi sequel *Star Trek II: The Wrath of Khan*. The laboratory on the Regula 1 space station served as the research and development testbed for Project Genesis, the classified terraformation project that Khan Noonien Singh (Ricardo Montalban) looked to commandeer for his own purposes. While reused in *Star Trek II*, the piece was originally built for *Star Trek: The Motion Picture* as the Orbital Office Complex's docking bay and saw reuse well into the late-1990s as Starbase 375 in *Star Trek: Deep Space Nine*.

This lot consists of a wooden frame with metal handles containing a miniature docking bay constructed of mixed media including wood, resin, and kitbashed plastic greebles painted in shades of gray. The rear of the miniature features an acrylic backing with an X-shaped insert and a pattern printed on a translucent cel that could be backlit. The lower left-hand corner is part of a runabout of the miniature, which was modified during the DS9 era. The outside of the component is marked "Trek 168" and "The End Up Only." It exhibits paint chipping, discoloration, scuffing, and loose or missing greebles. Dimensions: 48" x 24" x 42" (122 cm x 61 cm x 106.75 cm)

**Estimate: \$4,000 - 8,000**

17" (43.25 cm)

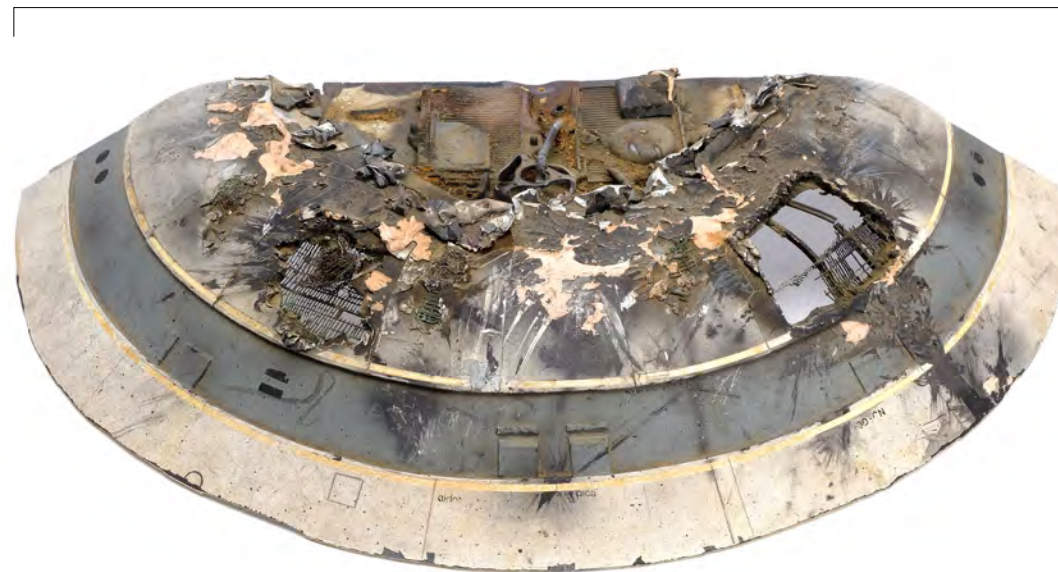

**361**  
Enterprise Bridge Destruction  
Model Miniature  
**Star Trek III: The Search For Spock**  
**(1984)**

An Enterprise bridge destruction model miniature from Leonard Nimoy's sci-fi sequel Star Trek III: The Search for Spock. Admiral James T. Kirk (William Shatner) made the difficult decision to set the Enterprise to self-destruct to save his crew, and it blew up the bridge and took out a Klingon boarding party with it.

This lot consists of a half-saucer built in mixed media including resin, plastic, foil, and various kitbashed greebles and grates, painted light and dark gray, with heavily applied distressing to simulate the results of a large explosion. Also included is a Letter of Authenticity from Eric Reiersen, confirming that the piece originally came from Industrial Light & Magic (ILM). The miniature exhibits some signs of use and age, including some paint flaking. Dimensions: 8.5" x 17" x 2.5" (21.75 cm x 43.25 cm x 6.5 cm)

**Estimate: \$5,000 - 10,000**



**362**  
Spock's (Leonard Nimoy) Ears  
**Star Trek IV: The Voyage Home**  
**(1986)**

Spock's (Leonard Nimoy) ears from Leonard Nimoy's sci-fi sequel Star Trek IV: The Voyage Home. Spock, who was half-Vulcan, had pointed ears that were an iconic characteristic of his character.

This lot consists of a pair of foam latex pointed ear tips and a Certificate of Authenticity reading "These Spock ears were used by Leonard Nimoy in 'Star Trek IV: The Voyage Home' June 1986" with a verification line hand-signed by Leonard Nimoy. The foam latex exhibits hardening and cracking from age. Dimensions: 3" x 3" x 0.5" (7.75 cm x 7.75 cm x 1.5 cm)

**Estimate: \$5,000 - 10,000**

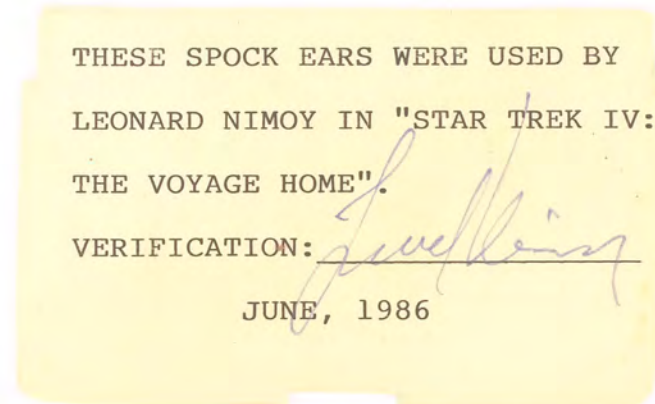

**363**  
Dr. Leonard "Bones" McCoy's (DeForest Kelley)  
Starfleet Medical Field Uniform  
**Star Trek V: The Final Frontier (1989)**

Dr. Leonard "Bones" McCoy's (DeForest Kelley) Starfleet medical field uniform from William Shatner's sci-fi film Star Trek V: The Final Frontier. McCoy wore his field uniform as he and his crewmates took a shuttle to the surface of Nimbus III as they tried to infiltrate Sybok's settlement.

This uniform consists of an orange knitted wool sweater with adhered shoulder and side pads, back snaps, an elastic stirrup, and a green armband with a commander rank pin; light brown wool trousers with a green stripe down the outside of each leg, and a green zip-back sleeveless undershirt with a quilted collar. All three pieces are marked for either Kelly or "McCoy." The uniform exhibits some staining.

**Estimate: \$3,000 - 6,000**



**364**  
Lieutenant Rank Operations Division Starfleet  
Female Maroon Uniform Jacket with Command  
Division Undershirt  
**Star Trek: Generations (1994)**

A lieutenant rank Operations division Starfleet female maroon uniform jacket with Command division undershirt from David Carson's sci-fi sequel Star Trek: Generations. It was worn by officers in Starfleet's service circa 2270-2350 in various configurations.

This uniform consists of a maroon wool single-breasted jacket with snap closures and tan poly-cotton paneled chest interior; a Command division white poly-blend turtleneck with a rear zip closure; and a leather belt with a brass-color metal Starfleet emblem buckle. The jacket features an Operations division gold-color shoulder stripe with a Lieutenant rank metal pin and a metal twist-lock fastener. The metal Starfleet emblem is attached at the left chest with a pin backing. This costume exhibits discoloration, glue marks, and loose threads.

**Estimate: \$5,000 - 10,000**

**365**  
 Captain Scott's (James Doohan)  
 Screen-Matched Maroon  
 Starfleet Uniform  
**Star Trek IV: The Voyage Home (1986)/**  
**Star Trek: Generations (1994)**

Captain Scott's (James Doohan) screen-matched maroon Starfleet uniform from Leonard Nimoy's Star Trek IV: The Voyage Home. "Scotty" wore his double-breasted, military-cut maroon uniform, which first appeared in Star Trek II: The Wrath of Khan, throughout the film.

While a Western Costume Co. labeled for "James Doohan" and production number "2795-2" demonstrates that this costume's jacket was made for The Voyage Home, it is also tagged "Star Trek VII: J. Doohan," suggesting it was worn in later films in the franchise. Indeed, creasing and stitching on the gold-color right shoulder strap screen-matches it to the beginning of Star Trek: Generations, when Scotty was aboard the new USS Enterprise-B with James Kirk (William Shatner) and Pavel Chekov (Walter Koenig).

This uniform consists of a maroon jacket with snap fastening closures on front, a Starfleet insignia on the left breast, and Scott's rank badge on the strap; black trousers with elastic suspenders and stirrups labeled "James Doohan" on two different labels; and a black leather belt with a metal Starfleet buckle. It exhibits stains on the interior and some fraying throughout the fabric.

**Estimate: \$10,000 - 20,000**

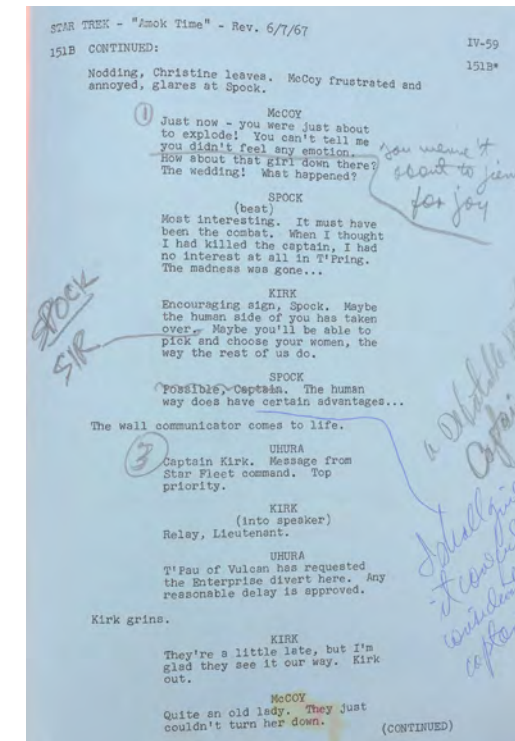
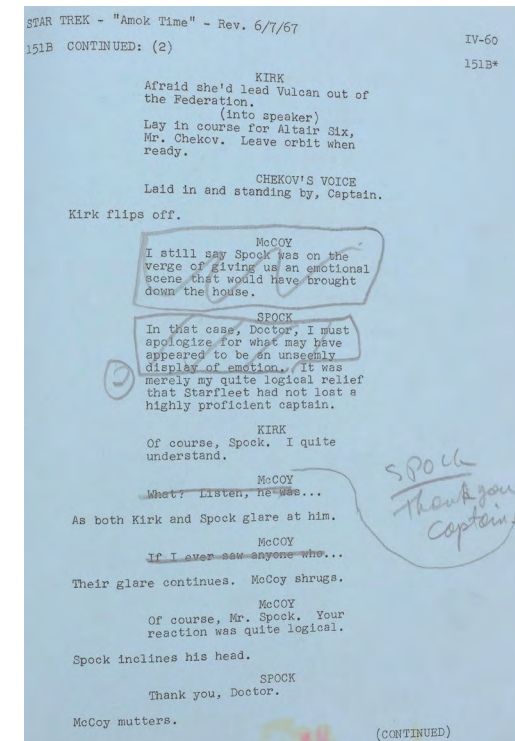
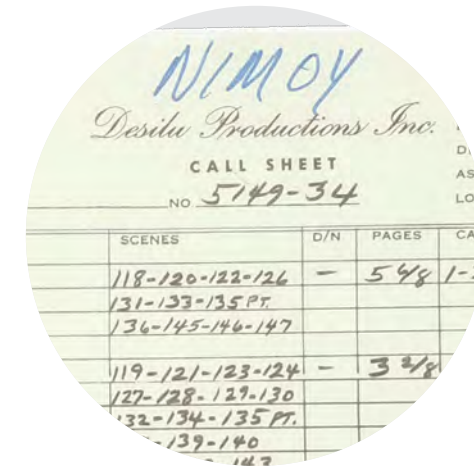
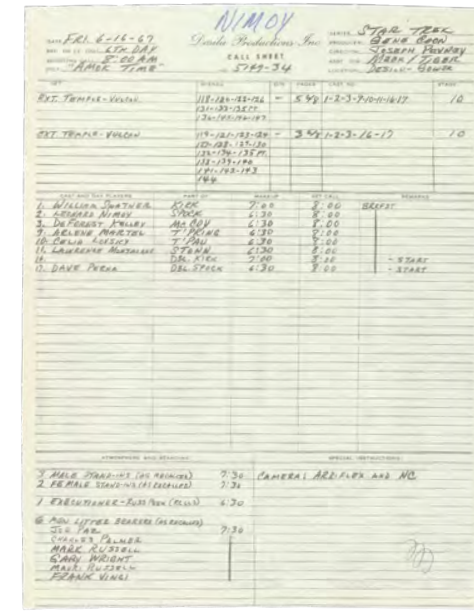

**366**  
 Leonard Nimoy's Annotated  
 Personal "Amok Time" Second  
 Revision Final Draft Script,  
 Schedule, Call Sheet, and Photo  
**Star Trek: The Original Series**  
**(1966-1969)**

Leonard Nimoy's annotated personal second revision final draft script, schedule, call sheet, and photo from the Season 2 episode "Amok Time" of Gene Roddenberry's Star Trek. The fan-favorite episode introduced many elements of Vulcan culture to the franchise, including the first use of the iconic Vulcan salute, the first instance of the phrase "Live long and prosper," and Spock's famous kal-if-fee fight against Captain James T. Kirk (William Shatner).

This lot consists of a brass brad-bound, 66-page script featuring a red Desilu Productions cover on which Nimoy hand-wrote his name; a printed shooting schedule hand-marked "Carl"; a seven-page call sheet dated June 16, 1967 and hand-marked "Nimoy"; and a color-printed glossy behind-the-scenes photo of Nimoy and Arlene Martel reading their scripts in costume as Spock and T'Pol. The script features 12 hand-annotated pages by Nimoy with dialogue changes and notes, and features multicolor change pages from production. The lot exhibits corner creasing throughout and the script exhibits staining. Dimensions: 8.5" x 11" x 0.5" (21.75 cm x 28 cm x 1.5 cm)

**Estimate: \$10,000 - 20,000**

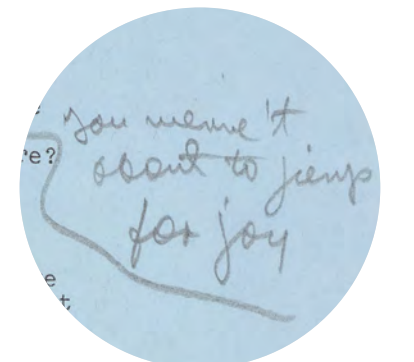





**367**  
 Spock's (Leonard Nimoy) Vulcan Ear Tips  
**Star Trek: The Original Series (1966-1969)**

Spock's (Leonard Nimoy) Vulcan ear tips from Gene Roddenberry's sci-fi series Star Trek. Pointy-eared half-human, half-Vulcan Spock relied on logic while serving as first officer aboard the USS Enterprise throughout the series. Designed by Fred Phillips for the pilot episode, "The Cage," Spock ears of this style are also held in the National Air and Space Museum.

This pair of cast foam rubber ear tip prosthetics are hand-painted in peach tones with beige outlines for shape. They come in a clear plastic box with a latch closure for protection from the elements. The tips exhibit discoloration, flaking along the bottoms, and curling to the rubber from production use, age, and exposure. They remain fragile and should be handled with caution.

**Estimate: \$10,000 - 20,000**

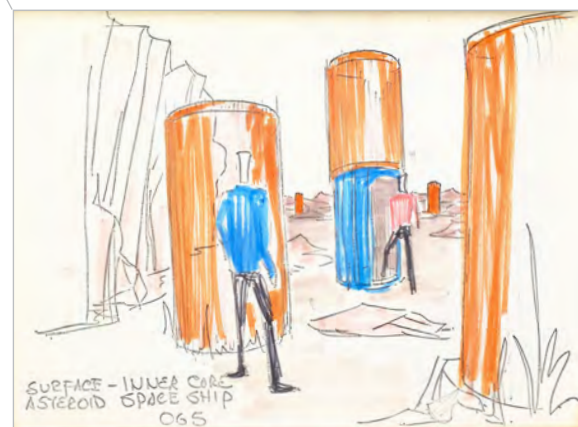
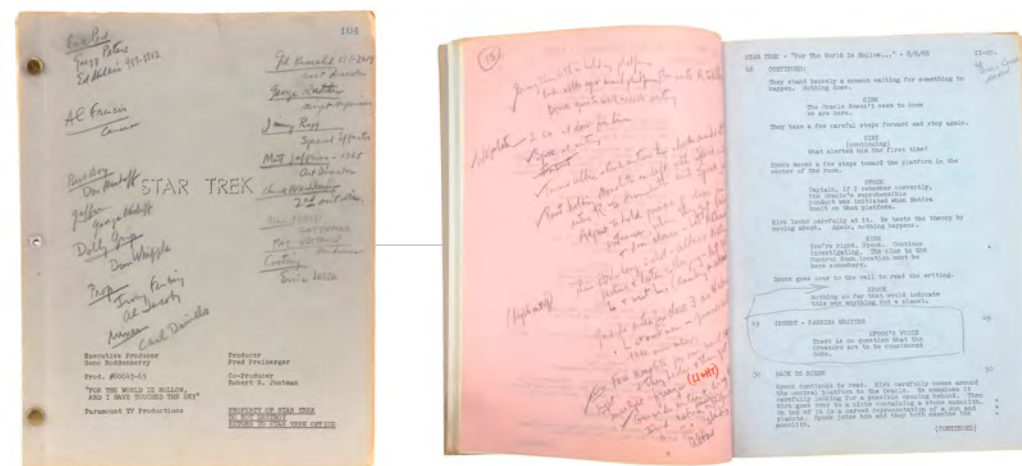

**369**  
 Tony Leader's Personal "For the World is Hollow and I Have Touched the Sky" Final Draft Script and Director's Paperwork  
**Star Trek: The Original Series (1966-1969)**

Tony Leader's personal final draft script and paperwork for the Season 3 episode "For The World Is Hollow and I Have Touched The Sky" of Gene Roddenberry's Star Trek, which he directed. This lot consists of a brass brad-bound, 65-page final draft script dated "August 7, 1968" with a gray cover with crew names handwritten on it; a five-page schedule; a cast and set list; a bridge overview diagram; nine pages of photocopied storyboards, some of which are hand-colored; and four contact sheets.

The script, the director's working copy, is heavily annotated with notes regarding pacing, dialogue, shot set-ups, camera angles, and details from both pre-production and the actual shoot. It exhibits some corner creasing and edge wear. Dimensions: 8.5" x 11" x 0.5" (21.75 cm x 28 cm x 1.5 cm)

**Estimate: \$6,000 - 12,000**

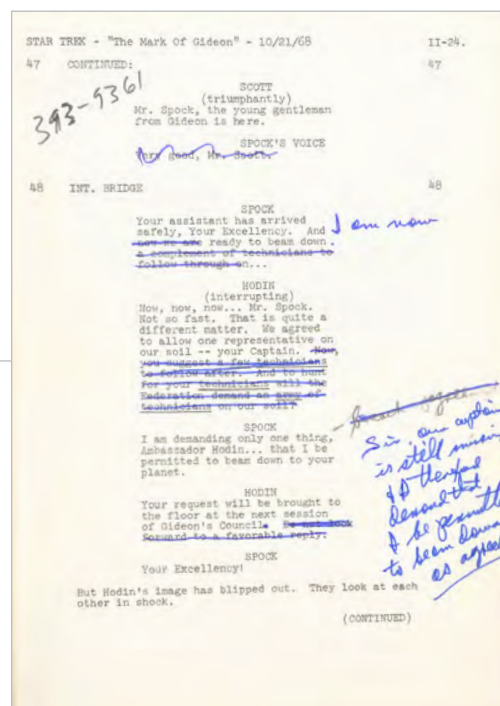
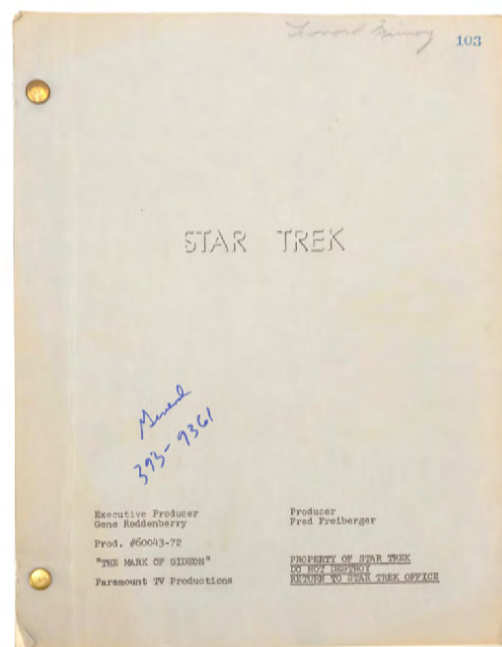

**368**  
 Leonard Nimoy's Annotated Personal "The Mark of Gideon" Final Draft Script  
**Star Trek: The Original Series (1966-1969)**

Leonard Nimoy's annotated personal final draft script for the Season 3 episode "The Mark of Gideon" of Gene Roddenberry's Star Trek: The Original Series. This brass brad-bound, 60-page final draft script was originally sourced from Nimoy's assistant Teresa Victor. It is dated "October 21, 1968" with blue revision pages and a gray cover. Nimoy hand-wrote his name on the cover and three additional times on the interior pages in his distinctive script, as well as writing other notes, including extensive dialogue changes that match the aired episode on 13 pages. The script exhibits some corner creasing, edge wear, and some pages exhibit torn corners. Dimensions: 8.5" x 11" x 0.5" (21.75 cm x 28 cm x 1.5 cm)

**Estimate: \$6,000 - 12,000**



**370**  
 "Hot Set" Sign  
**Star Trek: The Original Series (1966-1969)**

A "Hot Set" sign from the production of Gene Roddenberry's Star Trek: The Original Series. Signs designating a "hot set" indicated that a set was currently or imminently being used, and that no one should tamper with it.

This rectangular cardboard sign with a glossy white front with red font reading "Star Trek Hot Set No Food/Smoking On Set" and a gray back with "Crescent Quality Boards" watermarks was originally sourced from Leonard Nimoy's assistant Teresa Victor. It exhibits wear from use and age, including scratching, creasing, corner denting, and staining. Dimensions: 14.5" x 25" x 0.25" (37 cm x 63.5 cm x 0.75 cm)

**Estimate: \$5,000 - 10,000**



**371**  
**Klingon Costume Components**  
**Star Trek: The Original Series (1966-1969)**

Klingon costume components from Gene Roddenberry's sci-fi series Star Trek: The Original Series. The Klingons, fierce enemies of the Federation at that time, wore their distinctive costumes throughout their multiple run-ins with the crew of the starship Enterprise.

This lot consists of a sleeveless gold-color synthetic fabric vest with black horizontal striping and a pair of loosely woven black and gold-color synthetic ribbon leggings. The leggings exhibit fraying around the ankles, and the vest is stained on the left chest from wear.

**Estimate: \$5,000 - 10,000**

**THE JOHN CHAMBERS COLLECTION**

Renowned film and TV makeup artist John Chambers was born on September 12, 1922 in Chicago, Illinois. He served during World War II as a dental technician, and later worked at the Veterans Affairs hospital in Hines, Illinois, where he repaired faces and made prosthetic limbs for wounded veterans. In 1953, Chambers joined NBC, having previously trained under Ben Nye and worked as a makeup artist for live productions. After a six-year period at the network, Chambers completed his first film, *Around the World in Eighty Days*, which won the Academy Award® for Best Picture and launched his long career in Hollywood.

Under contract with Universal Pictures, Chambers first gained recognition for his work on both *The List of Adrian Messenger* and Gene Roddenberry's seminal sci-fi series *Star Trek*, for which he created the prosthetic Vulcan ears worn by Leonard Nimoy. Chambers then achieved global recognition for *Planet of the Apes*, which earned him an Academy Honorary Award for his groundbreaking prosthetic makeup from The Academy of Motion Picture Arts and Sciences in 1968 and cemented a long-standing association with the beloved franchise. The CIA even contracted Chambers to coach its operatives on creating disguise kits in the 1970s, for which he was awarded the agency's Intelligence Medal of Merit after the 1979 Iran hostage crisis was declassified.

John Chambers died on August 25, 2001, leaving behind an unparalleled legacy of innovation and artistry in makeup. Over Chambers' career, several other accomplished makeup artists received his tutelage, including Michael Westmore, Maurice Stein, Thomas R. Burman, Michael McCracken, David Dittmar, and many more, and his work remains on display at the International Spy Museum in Washington D.C. Propstore is proud to offer select lots from this legendary artist's personal collection, encapsulating a career spanning decades in Hollywood and beyond, to the world for the very first time.



**372**  
**John Chambers Collection: Spock's (Leonard Nimoy) Wax Prosthetic Ear Sculpt**  
**Star Trek: The Original Series (1966-1969)**

Spock's (Leonard Nimoy) wax prosthetic ear sculptures from the adventure-sci-fi series *Star Trek*. Spock served as first officer under Captain James T. Kirk (William Shatner) aboard the USS Enterprise.

This lot comes from the collection of SFX makeup artist John Chambers. It consists of two wax pointed ear prosthetics; an 8.5" x 10" black-and-white photo of Spock with a label "Leonard Nimoy's Dr. Spock ears were a production of John Chambers expertise" and handwritten annotations "I created the ears for Mr. Spock in 1965 or 1966" and "I took 2 impressions of Leonard Nimoy's ears for Star Trek on June 1, 1966 at 3:30 pm and April 17, 1968"; two color images of Nimoy and Chambers in makeup; and 44 pages of receipts with handwritten annotations from Chambers inside a manila folder with hand annotations. This lot exhibits discoloration on the receipts and numerous tears in the folder from age. Dimensions: 8.5" x 10" (21.75 cm x 25.5 cm)

**Estimate: \$5,000 - 10,000**



**373**  
**John Chambers Collection: John Chambers' Briefcase with Real-World Argo and CIA Documents**  
**John Chambers Collection**

John Chambers' briefcase with Real-World Argo and CIA documents from the 1970s and 1980s. Chambers was commissioned by the CIA to create "disguise kits" that assisted in the escape of six American hostages from Iran.

This lot comes from the personal collection of John Chambers. CIA officer Tony Mendez recruited Chambers as part of the 1980 "Canadian Caper" during the Iran hostage crisis. As a well-established Hollywood makeup artist, Chambers participated in the clandestine operation under the guise of producing a fictional science-fiction film called *Argo*, whose script required exotic locales, such as those in Iran. His efforts led to the escape of six American embassy personnel and his reception of the CIA's Intelligence Medal of Merit. Following the 1997 declassification, director-producer Ben Affleck led the 2012 Academy Award winning film *Argo*, where Affleck portrayed Mendez and John Goodman portrayed Chambers. This lot consists of a 16mm miniature camera; 58 transparency films; a phone handset microphone marked "J.C."; a brown vinyl 1980 daily diary with handwritten notes; a gold-color 1975 calendar booklet marked "1975" with handwritten notes; five black-and-white photos; 36 "Argo" related Polaroids; 19 photos in a manila envelope marked "CIA"; three "The Hollywood Reporter" magazines from 1980; a 1980 Variety Daily article with "Argo" hand-annotated in red; eight pages of Studio Six Productions' tax returns; two Studio Six Productions folders with 38 pages and nine photos; five newspaper pages; a four-page Studio Six Productions tenant agreement; 538 pages of miscellaneous documents and receipts; and one gray briefcase labeled "John Chambers" with his mailing address. This lot exhibits discoloration, tape residue, grime, and sticky and folded pages from age. Dimensions: 17" x 12.5" x 4" (43.25 cm x 31.75 cm x 10.25 cm)

**Estimate: \$10,000 - 20,000**



**374**  
Ruk the Android's (Ted Cassidy)  
Screen-Matched Costume  
**Star Trek: The Original Series (1966-1969)**

Ruk the Android's (Ted Cassidy) screen-matched costume from Gene Roddenberry's *Star Trek: The Original Series*. In the Season 1 episode "What Are Little Girls Made Of?," the android Ruk wore his costume while serving Roger Korby (Michael Strong) on Exo III, just as he had served the Old Ones half a million years earlier.

This lot consists of a long gray robe knit with woolen and metallic fibers featuring a hood with snaps, a fastening strip back, a metallic trim of tiny wire loops along the edges of the open front, a multicolor linen lining, and a matching multicolor linen inner robe featuring padding in the chest and shoulders. This piece has been screen-matched to its distinctive collar patterning. The linen exhibits fraying and the trim has several tears in it.

**Estimate: \$6,000 - 12,000**



**375**  
Data's (Brent Spiner) Screen-Matched Distressed  
Starfleet Uniform Jacket  
**Star Trek: The Next Generation (1987-1994)**

Data's (Brent Spiner) distressed Starfleet uniform jacket from the sci-fi series *Star Trek: The Next Generation*. This jacket screen-matches to the scene in the Season 5 episode "Disaster" in which Data blocked an arc of electricity after he and William Riker (Jonathan Frakes) were trapped in a crawlspace.

This black and mustard-color polyester blend jacket features black satin lining, an elasticized band around the hem, and a zip to fasten along the back. A small strip of a hook-and-loop fastener is located on the left breast of the jacket. This jacket is distressed in the center with latex painted gray to give the effect of it being burned. This jacket also comes with two hand-marked production tags and a label sewn inside hand-marked with "Spiner" in faded ink. This lot exhibits some fading and fabric pilling.

**Estimate: \$6,000 - 12,000**



**376**  
Wesley Crusher's (Wil Wheaton)  
Screen-Matched Head Wrap and  
Command-Division Tunic  
**Star Trek: The Next Generation  
(1987-1994)**

Wesley Crusher's (Wil Wheaton) screen-matched head wrap and Command Division tunic from Gene Roddenberry's sci-fi series *Star Trek: The Next Generation*. The screen-matched head wrap comes from Season 4, episode 9 "Final Mission," after the shuttlepod Nenebek crashed on a desert planet.

This lot consists of a black and maroon wool command division Starfleet uniform tunic lined with black satin, and a black leather headwrap. The tunic features a raised collar with red piping along its edge and a rear zipper with hook-and-eye closures. The tunic features a Paramount tag on the interior hand-marked faintly with "Wil." The inside of the headwrap is hand-marked as well with "Wil," but the text is largely illegible. This costume exhibits some discoloration on the tunic and the underside of the head wrap from production.

**Estimate: \$4,000 - 8,000**



**377**  
Dr. Beverly Crusher (Gates McFadden) and Dr. Katherine Pulaski's (Diana Muldaur)  
Light-Up Electronic Medkit  
**Star Trek: The Next Generation (1987-1994)**

Dr. Beverly Crusher (Gates McFadden) and Dr. Katherine Pulaski's (Diana Muldaur) light-up electronic medkit from the sci-fi series *Star Trek: The Next Generation*. Crusher and her brief replacement, Pulaski, carried medical equipment in a medkit. This piece was first introduced in Season 1's "Lonely Among Us," and saw reuse throughout the series in various configurations, including Season 5's "Cause and Effect" in Crusher's quarters; this configuration is as-seen in *Star Trek: First Contact*, on a shelf cart when Crusher activates the EMH (Robert Picardo) to delay the Borg.

This light-up gray painted thermoformed plastic case is reinforced with wood strips and gray inserted with foam padding. The interior features the following vinyl details: silver pinstripe squares, white pinstriping, white numbering, and repurposed tricorder graphics. The case exterior features white vinyl pinstriping and tape across surface faces, a white screen-printed Caduceus on front; sparse silver-color vinyl pinstripe rectangles; a back-lit yellow, amber, and purple translite LCARS interface with red, blue, and green round-cut acrylic inlays at top left; and two small circular LED light features (red on the top, green on the side). Three different switches power various light features. The lot exhibits scratches, paint chips, scuffing, color fading, foam disintegration, and missing side detail. Dimensions: 11" x 12" x 4.5" (28 cm x 30.5 cm x 11.5 cm)

Contains electronics; see electronics notice in the Buyer's Guide.

**Estimate: \$8,000 - 16,000**

36" (91.5 cm)



**378**  
**Light-Up QMx Replica Studio-Scale USS Enterprise NCC-1701-D Promotional Model**  
**Star Trek: The Next Generation (1987-1994)**

A light-up QMx replica studio-scale promotional model of the USS Enterprise NCC-1701-D from Gene Roddenberry's sci-fi series Star Trek: The Next Generation. Captain Jean-Luc Picard (Sir Patrick Stewart) and his crew explored the final frontier aboard this 24th century Enterprise.

This lot consists of the Quantum Mechanix (QMx) convention display and sales page photography model constructed in clear gel coated fiberglass mounted to a steel endoskeletal frame. Its surface features an enamel painted ivory, gray, and mid-blue gray Aztec-pattern atop a blue-gray base coat, with additional enamel painted yellow umber and dark gray detailing. Over 100 LED lights emulate functioning engines, formation signals, a deflector dish, and windows. The model is backed by sound features for phaser and torpedo sounds, all controlled via a keyless fob attached to a translucent neon green acrylic isolinear chip. Its underside features a separate power connection and features two acrylic supports with multiple rods and layered combadge insignia placed on a black acrylic inlay in the shape of the Engineering "pool table" console atop a gray painted MDF base. The display features two dark pewter-color painted resin-cast Starfleet badges, an aluminum plaque featuring "QMx FX Cinema Arts" with its "0 of 50" edition number, and an unsigned aluminum signature plate. A wood shipping crate with black painted "NCC-1701-D" on the side, and custom-cut egg-crate foam layers, is included for conveyance. The lot exhibits scuffing, scratching, missing decals, cracking, and edge wear. Dimensions: (on base) 36" x 28" x 11" (91.5 x 71.25 cm x 28 cm)

Contains electronics; see electronics notice in the Buyer's Guide.

**Estimate: \$10,000 - 20,000**

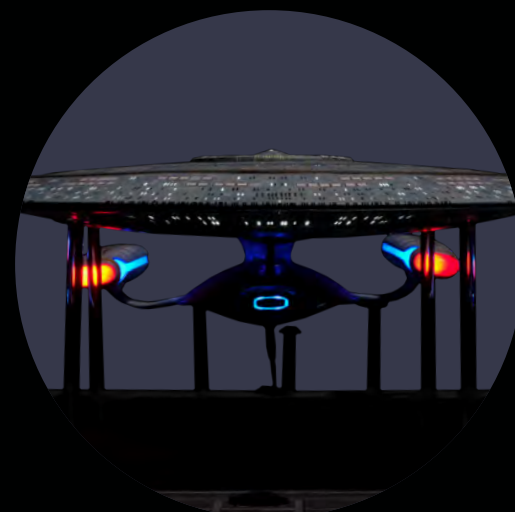

**379**  
**Light-Up Ferengi Tricorder with Rick Sternbach's Original Hand-Drawn Concept Sketch**  
**Star Trek: The Next Generation (1987-1994)**

A light-up Ferengi tricorder with Rick Sternbach's original hand-drawn concept sketch from Gene Roddenberry's sci-fi series Star Trek: The Next Generation. The tricorder debuted in Season 5's "The Perfect Mate" when Qol (Michael Snyder) caused Kamala's (Famke Janssen) premature emergence.

The tricorder is pewter- and bronze-color painted to resemble metal with various grill-textured buttons and two heat-sink style protrusions; a paper-printed, fluorescent multicolor screen with dingbat iconography; colored blinking lights; a miniature circuit board and faux antennae; and a trapezoidal plate allowing for battery access. A slide switch activates the dimly lit lights. A letter-sized, three-hole punched paper sketch hand-rendered in black ink with blue linework is hand-marked "Sternbach" and dated "2-92." The lot exhibits missing switch cover, scratching, chipping, pitting, and edge wear. Dimensions: (tricorder) 7" x 3.5" x 2" (18 cm x 9 cm x 5 cm); (sketch) 11" x 8.5" (28 cm x 21.5 cm)

Contains electronics; see electronics notice in the Buyer's Guide.

**Estimate: \$4,000 - 8,000**



**380**  
**Light-Up Klingon Tricorder**  
**Star Trek: Deep Space Nine (1993-1999)**

A light-up Klingon tricorder from Rick Berman and Michael Piller's sci-fi series Star Trek: Deep Space Nine. Shakaar (Duncan Regehr) and Furel (William Lucking) took various equipment, including a Klingon tricorder, from an old resistance supply cache in Season 3's "Shaakar."

This metal light-up tricorder with resin details is painted dark reddish-brown, with black painted contrast details and buttons throughout; a red rectangle and silver-color gray back inset ribbed panel; and side-riveted rubberized plastic strap holders. A beak-shaped front center grip features dark green painted triangles, with a silver-color metal push button on the beak ridge that pops up the spring-loaded "neck," activates randomly flashing lit squares, and reveals two red sequence-flashing LED-backed acrylic triangles. The lot exhibits chipped pieces and paint, scratches, grime, and a missing strap. Dimensions: 8" x 5" x 3" (20.25 cm x 12.75 cm x 7.75 cm)

Contains electronics; see electronics notice in the Buyer's Guide.

**Estimate: \$4,000 - 8,000**



**381**  
**Cardassian Recording Console from "In the Pale Moonlight" with Optolythic and Isolinear Data Rods**  
**Star Trek: Deep Space Nine (1993-1999)**

A Cardassian recording console from Season 6's "In the Pale Moonlight." Captain Benjamin Sisko (Avery Brooks) and Elim Garak (Andrew Robinson) recruited criminal programmer Grathon Tolar (Howard Shangraw) to fabricate a recording of Dominion personnel planning a Romulan Empire attack.

The lot features five acrylic data rods that insert into the console, a gray-brown painted MDF featuring angular, beveled, and ribbed detailing; black plexiglass with multicolor circuitry artwork backlit by fluorescent bulbs; two circular decals in Cardassian iconography, and additional silver and gray pin-stripping details that have been sympathetically restored on top of the plexiglass. Five holes allow for drop-in rod placement, while a two-prong power cord runs through a hole in the base. Included are four "isolinear" rods with orange and black pinstripping, and one "optolythic" rod with blue pinstripping and red tape. It exhibits paint scratching, chipping, and scuffing. Dimensions: 20" x 17.25" x 14" (51 cm x 44 cm x 35.75 cm)

Contains electronics; see electronics notice in the Buyer's Guide.

**Estimate: \$4,000 - 8,000**



**382**  
**Q's (John de Lancie) Starfleet Uniform Combadge and Undershirt**  
**Star Trek: Voyager (1995-2001)**

Q's (John de Lancie) Starfleet uniform combadge and undershirt from the sci-fi television series Star Trek: Voyager. The tricky Q wore his Starfleet uniform in the Star Trek: Deep Space Nine episode "Q-Less" and subsequently in Voyager. The gray, long-sleeve undershirt features two Voyager labels, reading "John de Lancie" and "Size 44 Long." The resin combadge has a hook-and-loop patch on the back and "x76" handwritten in black ink on the back.

**Estimate: \$5,000 - 10,000**

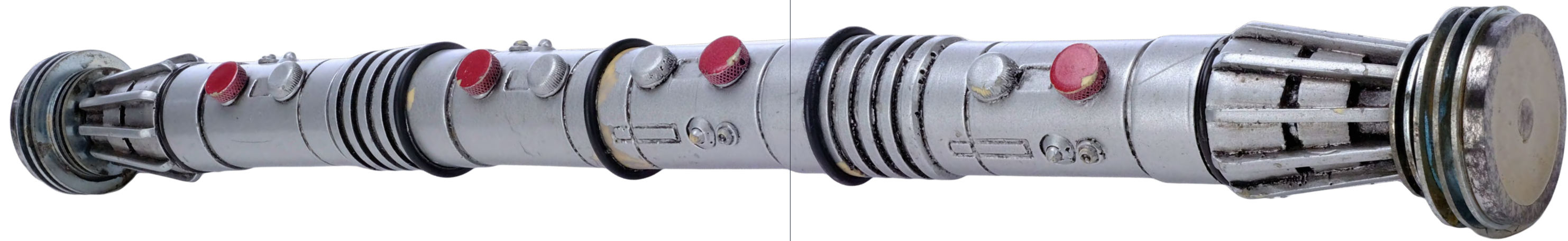

**383**  
**Darth Maul's (Ray Park) Lightsaber**  
**Star Wars: Episode I - The Phantom Menace (1999)**

Darth Maul's (Ray Park) lightsaber from George Lucas' Star Wars: The Phantom Menace. Darth Maul used his iconic double-bladed lightsaber during the climactic fight against Qui-Gon Jinn (Liam Neeson) and Obi-Wan Kenobi (Ewan McGregor) in the Theed Palace on Naboo.

Darth Maul was skilled in the ways of the dark side, creating the saberstaff as his signature weapon. Although the double-bladed lightsaber was first seen on screen in The Phantom Menace, it originated in the comic-book series Star Wars: Tales of the Jedi.

The double-ended hilt is cast in resin, with machined film-specific steel end caps, and an internal steel core running through the weapon's body for weight and strength. It is finished in silver color paint, with shades of dark gray to give depth to the detailing throughout, including the two ribbed hand grips and parts of the blade-emitter plate. Four metallic red activator buttons and four silver color control lock buttons span the hilt's length, and there are three incorporated black rubber O-rings. The lot exhibits paint wear which has exposed the resin in places, and cracking on the rubber. Dimensions: 21" x 2" x 2" (53.5 cm x 5 cm x 5 cm)

**Estimate: \$50,000 - 100,000**





**384**  
**Obi-Wan Kenobi's (Ewan McGregor) Hero Lightweight**  
**Lightsaber**  
**Star Wars: Episode I - The Phantom Menace (1999)**

Obi-Wan Kenobi's (Ewan McGregor) hero lightweight lightsaber from George Lucas' Star Wars: The Phantom Menace. Obi-Wan carried his lightsaber throughout the film as he acted as Qui-Gon Jinn's (Liam Neeson) Padawan apprentice. It also appeared on page 21 of Star Wars: The Complete Visual Dictionary.

Star Wars: The Phantom Menace introduced audiences to the world before A New Hope, and thus a younger Obi-Wan. The film shattered numerous box office records, and dethroned Jurassic Park's records for both largest single-day gross and fastest to gross \$100 million USD in five days. This prequel film was nominated for numerous Academy Awards®, BAFTA®, and Grammy Awards® for technical and musical achievements.

This lightsaber hilt is predominantly resin with several static switches, a black circular fixture where it was previously attached to a belt clip, and a steel blade emitter, a feature unique to the film's lightsaber props. It also features horizontal cut-outs in the black grip which distinguish it as a lightweight stunt-style hilt, as the aluminum hero hilts featured silver cut-outs. The black iteration appeared onscreen in numerous shots. The lot exhibits some wear to the paint and small chips in the resin. Dimensions: 11" x 2" x 2" (30 cm x 5 cm x 5 cm)

**Estimate: \$40,000 - 80,000**



**385**  
 Qui-Gon Jinn's (Liam Neeson)  
 Dueling Lightsaber with Replica Blade  
**Star Wars: Episode I - The Phantom Menace (1999)**

Qui-Gon Jinn's (Liam Neeson) dueling lightsaber from George Lucas' Star Wars: The Phantom Menace with a replica blade. The Jedi Master wielded his lightsaber throughout the film, including when he dueled with Sith apprentice Darth Maul (Ray Park) on Tatooine and in Naboo's Theed Palace. Qui-Gon's lightsaber was subsequently used by Obi-Wan Kenobi (Ewan McGregor) to avenge his master.

Many variations of lightsabers were designed for the film by design director Doug Chiang, with each Jedi having a uniquely crafted lightsaber designed to reflect their personality. Liam Neeson personally picked this design for his character.

This lightsaber features a hilt constructed from resin for stunt fight purposes with ribbed detailing running from the blade emitter down to the base, a red static activator switch on one side, and a black and silver paint finish. A thin metal rod is cast into the projection plate and affixed with a green aluminum replica M8-style blade for display.

The hilt exhibits paint wear, light scratches and notable scuff marks down one side from production, while bubble marks from the casting process are still present and the metal rod exhibits discoloration from age. Dimensions: 50" x 2" x 2" (127 cm x 5 cm x 5 cm)

**Estimate: \$20,000 - 40,000**

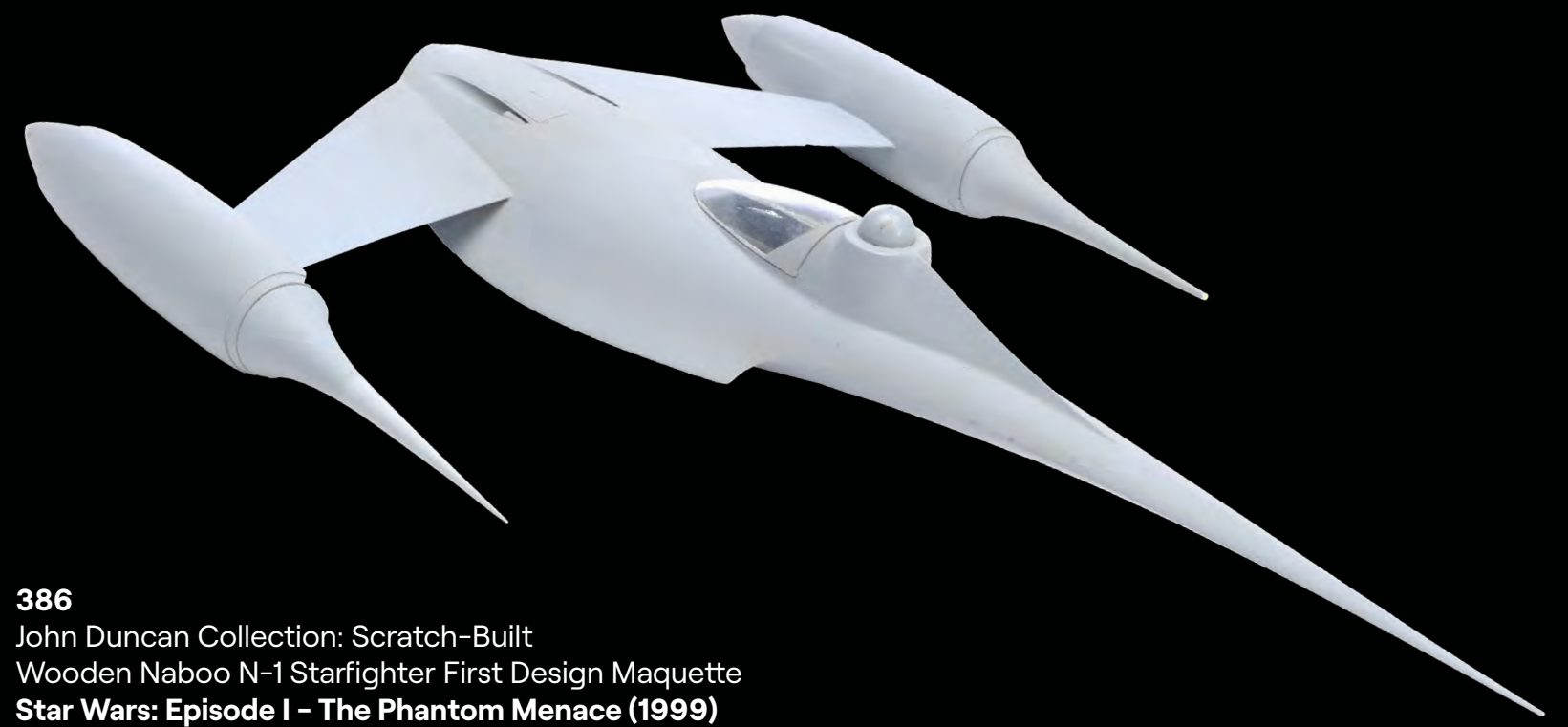

**386**  
 John Duncan Collection: Scratch-Built  
 Wooden Naboo N-1 Starfighter First Design Maquette  
**Star Wars: Episode I - The Phantom Menace (1999)**

A scratch-built wooden design maquette of a Naboo N-1 Starfighter from the production of George Lucas' Star Wars: The Phantom Menace. The N-1 was the high-speed, single-pilot fighter used by Naboo's forces in space combat.

This gray wooden N-1 maquette comes from the collection of concept model maker John Duncan, who designed and built it. It features a clear plastic cockpit dome and is mounted to a black wooden base. Also included is a white foam board stand. Being an earlier design, this maquette has some subtle differences from the final model, most notably where the wings connect to the main body of the starship. Recently this maquette underwent minor restoration by the original artist. The original design was by Doug Chiang, and as a favorite of Star Wars fans, this design now appears on The Mandalorian. It exhibits minor wear from age, including scuffing to the finish of the base. Dimensions: (starfighter) 9.25" x 15.5" x 1.5" (23.5 cm x 39.5 cm x 4 cm)

**Estimate: \$10,000 - 20,000**

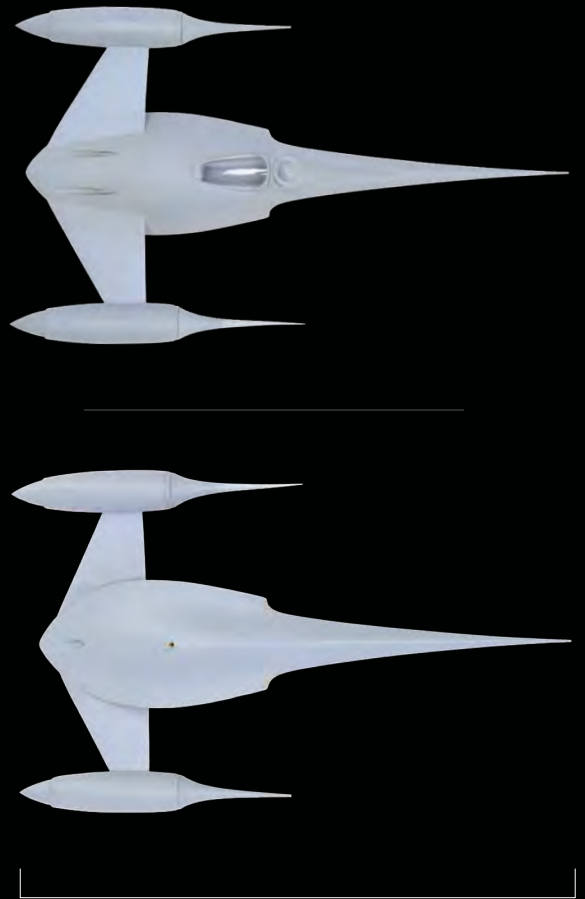

15.5" (39.5 cm)



**387**  
**Obi-Wan Kenobi's (Ewan McGregor) Short-Bladed Lightsaber**  
**Star Wars: Episode I - The Phantom Menace (1999)**

Obi-Wan Kenobi's (Ewan McGregor) short-bladed lightsaber from George Lucas' Star Wars: The Phantom Menace. Jedi Padawan Obi-Wan wielded his signature blue lightsaber throughout the film, including during his and Qui-Gon Jinn's (Liam Neeson) duel with Darth Maul (Ray Park).

This lightsaber hilt features a ridged resin and metal handgrip and a rounded pommel cap, all painted silver-color, black, red, and gold-color to simulate a metallic finish. Unlike the full-length aluminum blades, this hilt is inset with a half-length plastic lightsaber "blade" painted green to be digitally overlaid with VFX in shots where Kenobi swung his saber. Multiple behind-the-scenes images show McGregor wielding this style of saber. This hilt is missing a charging port or waist clip, suggesting it was built exclusively for dueling sequences. It exhibits visible scuffing, exposing resin throughout the grip and pommel, and the blade's tip is chipped. Dimensions: 22" x 2" x 2" (56 cm x 5 cm x 5 cm)

**Estimate: \$30,000 - 60,000**



Ewan McGregor on set with a short-bladed lightsaber prop, as seen in a production still printed in Star Wars Insider.



22" (56 cm)



**388**  
**Jar Jar Binks Reference Maquette**  
**Star Wars: Episode I - The Phantom Menace (1999)**

A Jar Jar Binks reference maquette from the production of George Lucas' Star Wars: The Phantom Menace. The clumsy Jar Jar Binks (Ahmed Best) accompanied Obi-Wan Kenobi (Ewan McGregor) and Qui-Gon Jinn (Liam Neeson) to Tatooine and fought the Trade Federation's clone army alongside his fellow Gungans.

Created by Industrial Light & Magic (ILM) as a character design reference, this unpainted gray resin maquette is ornately detailed with dangling ears, extended eyes, and three-toed feet mounted to a particle board base. This maquette was sculpted by Terry Whitlatch, who did many designs for Jabba the Hut. It exhibits adhesive residue on the head and minor fractures throughout from production and age. Dimensions: 6" x 5" x 13" (15.25 cm x 12.75 cm x 33 cm)

**Estimate: \$4,000 - 8,000**



**389**  
**John Duncan Collection: Naboo N-1 Starfighter Design Maquette Casting**  
**Star Wars: Episode I - The Phantom Menace (1999)**

A casting of a design maquette of a Naboo N-1 Starfighter from the production of George Lucas' Star Wars: The Phantom Menace. The N-1 was the high-speed single-pilot fighter used by Naboo's forces in space combat.

Cast from the original wooden model of an N-1 ship, this unpainted gray resin maquette comes from the collection of concept model maker John Duncan. It features intricate details, including the blending of the wings into the side of the ship, lines representing hull plating, engines and inner cockpit details. Also included is a white foam board stand. The casting exhibits minor stains and a bit of flash remaining around the front edge. Dimensions: (starfighter) 9" x 15.5" x 1.5" (23 cm x 39.5 cm x 4 cm)

**Estimate: \$5,000 - 10,000**

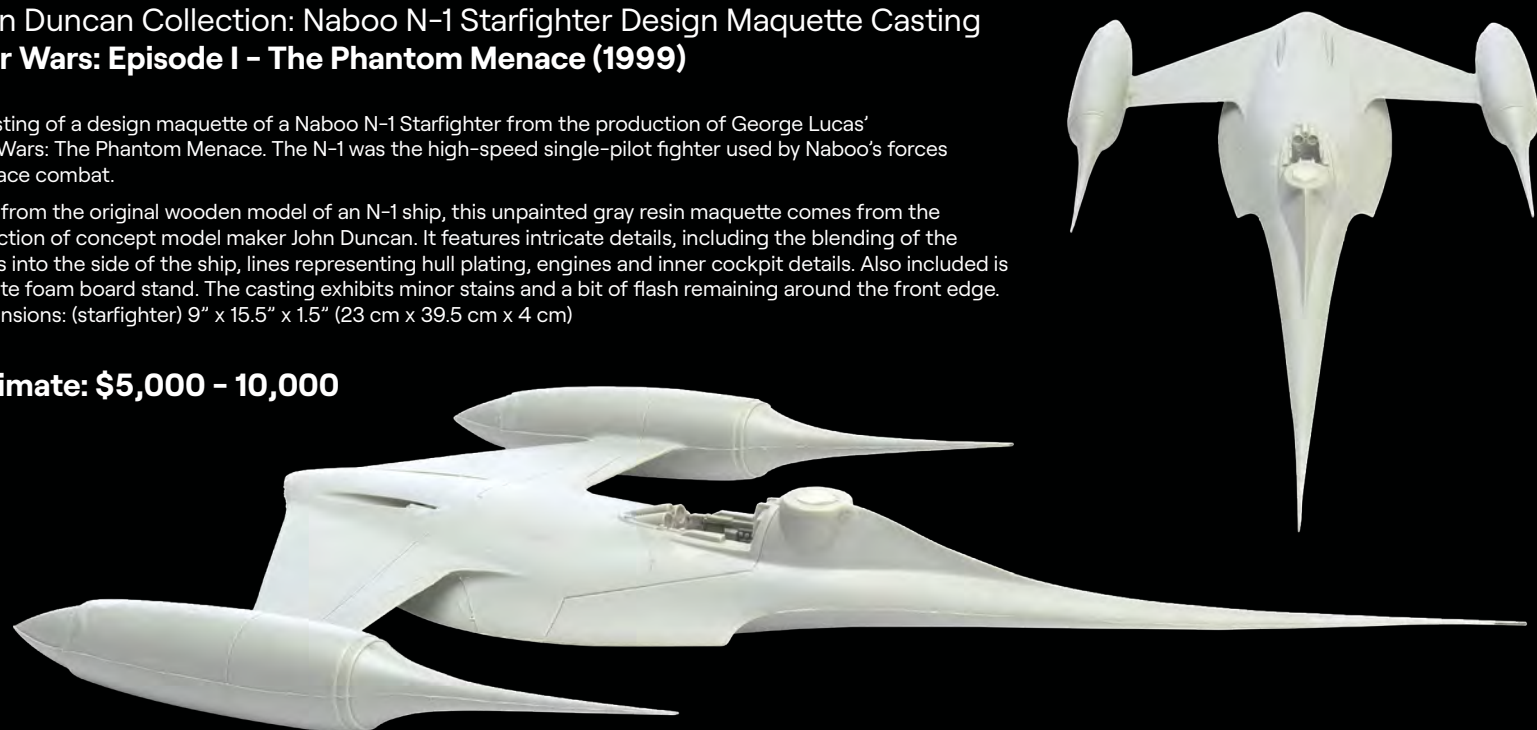

Emitter Detail

**390**  
**Mace Windu's (Samuel L. Jackson)**  
**Hero Lightweight Lightsaber**  
**Star Wars: Episode I**  
**- The Phantom Menace (1999)**

Mace Windu's (Samuel L. Jackson) hero lightweight lightsaber from George Lucas' Star Wars: The Phantom Menace. Mace Windu was a prominent member of the Jedi Council who assessed Anakin Skywalker's (Jake Lloyd) eligibility for training in the Jedi arts and counseled Yoda and other Jedi masters. He wore his lightsaber on his belt during the celebrations on Naboo at the end of the film. This lightsaber hilt is predominantly resin with a steel blade emitter, a feature unique to the film's lightsaber props. It is painted silver color with black detailing, has several static switches, and a black circular fixture where it was previously attached to a belt clip. It exhibits minor wear to the paint and some small chips in the resin. Dimensions: 10.5" x 1.75" x 1.75" (26.75 cm x 4.5 cm x 4.5 cm)

**Estimate: \$15,000 - 30,000**



10.5" (26.75 cm)



**391**  
**Adi Gallia's (Gin Clarke) Hero Lightweight Lightsaber**  
**Star Wars: Episode I - The Phantom Menace (1999)**

Adi Gallia's (Gin Clarke) hero lightweight lightsaber from George Lucas' Star Wars: The Phantom Menace. Adi Gallia was a member of the Jedi Council who assessed Anakin Skywalker's (Jake Lloyd) eligibility for training in the Jedi arts. Although the lightsaber is not seen in the film, it does appear with Gallia on page 17 of Star Wars: The Complete Visual Dictionary. This style of lightsaber was also used by Bultar Swan (Mimi Daraphet) and Agen Kolar (Tux Akindoyeni) in Attack of the Clones and Revenge of the Sith, respectively (pages 126 and 163 in the Complete Visual Dictionary).

This lightsaber hilt is predominantly resin with a steel blade emitter, a feature unique to the film's lightsaber props. It is painted silver-color with black detailing, has several static switches, and a swiveling clip to hook onto a belt. It exhibits minor paint wear from production use and age. Dimensions: 10" x 2.5" x 2" (25.5 cm x 6.5 cm x 5 cm)

**Estimate: \$10,000 - 20,000**



Star Wars: Episode I - The Visual Dictionary by David West Reynolds, published by DK.

**392**  
**Plo Koon (Matt Sloan) Dueling Lightsaber Hilt**  
**Star Wars: The Phantom Menace (1999)/Star Wars: Attack Of The Clones (2002)**

A Plo Koon (Matt Sloan) dueling lightsaber hilt from George Lucas' Star Wars: The Phantom Menace and Star Wars: Attack of the Clones. Designed and built by the production's props department for background Jedi seen in The Phantom Menace, this style of hilt became specifically associated with Plo Koon, a Kel Dor Jedi Master on the Jedi High Council, in Attack of the Clones.

This hilt features a resin and metal handgrip with a tapered pommel cap inset with a threaded rod. It is painted silver-color, black, and red to simulate a metallic finish. The threaded rod allowed for installation of aluminum blades that were used for dueling sequences and replaced frequently as they were damaged on set. The resin exhibits scuffs and cracks throughout from production use, with a small ridge piece broken off near the blade end. Dimensions: 14.25" x 2.75" x 2.25" (36.25 cm x 7 cm x 5.75 cm)

**Estimate: \$8,000 - 16,000**

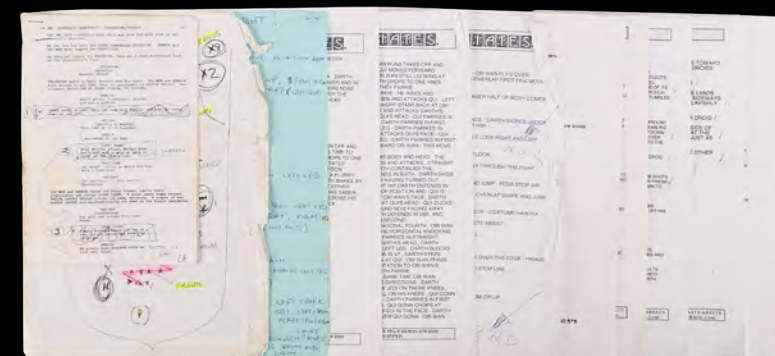
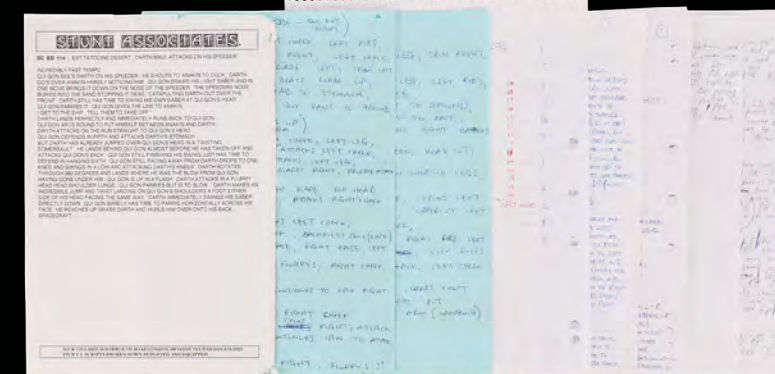
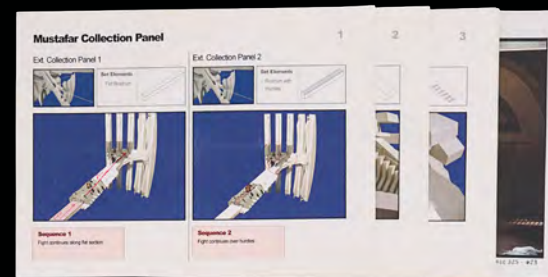

**393**  
**Nick Gillard Collection:**  
**Handwritten and Printed**  
**Lightsaber Fight Choreography**  
**Star Wars: Episode I - The Phantom Menace (1999)**

Handwritten and printed lightsaber fight choreography from the production of George Lucas' Star Wars: Episode I - The Phantom Menace. This lot comes from the collection of stunt coordinator and sword master Nick Gillard.

The collection is comprised of 88 pages featuring handwritten and printed lightsaber fight choreography plans for numerous fights throughout the film, including Obi-Wan versus Anakin/Vader, Obi-Wan versus Darth Maul, and Palpatine versus Yoda. These sheets include hand-drawn diagrams, a behind-the-scenes stunt photo, printed reshoot scene stills, and set model imagery of the Mustafar mining facility. The collection exhibits significant creasing, minor tears, and staining from production use and age. Dimensions: (folder) 14" x 9.5" x 0.5" (35.5 cm x 24 cm x 1.5)

**Estimate: \$1,500 - 3,000**

**394**  
**Nick Gillard Collection:**  
**Large Collection of Storyboards**  
**and FX Live Action Reshoot Binder**  
**Star Wars: Prequel Trilogy (1999-2005)**

An extensive collection of storyboards and an FX live-action reshoot binder from the production of George Lucas' Star Wars: Attack of the Clones and Star Wars: Revenge of the Sith. This lot comes from the collection of celebrated stunt coordinator and sword master Nick Gillard.

The collection consists of 365 printed storyboards showing battle scenes split into 13 sets and a binder labeled "Box Lunch Reshoots" containing 32 pages detailing all the FX live-action reshoots needed for Attack of the Clones. Several storyboards display handwritten annotations and completing the lot is an "Episode II" shooting schedule. The lot exhibits corrosion marks, minor rips and creasing. Dimensions: (binder) 11.75" x 10" x 1" (29.5 cm x 25.5 cm x 2.5 cm)

**Estimate: \$2,000 - 4,000**

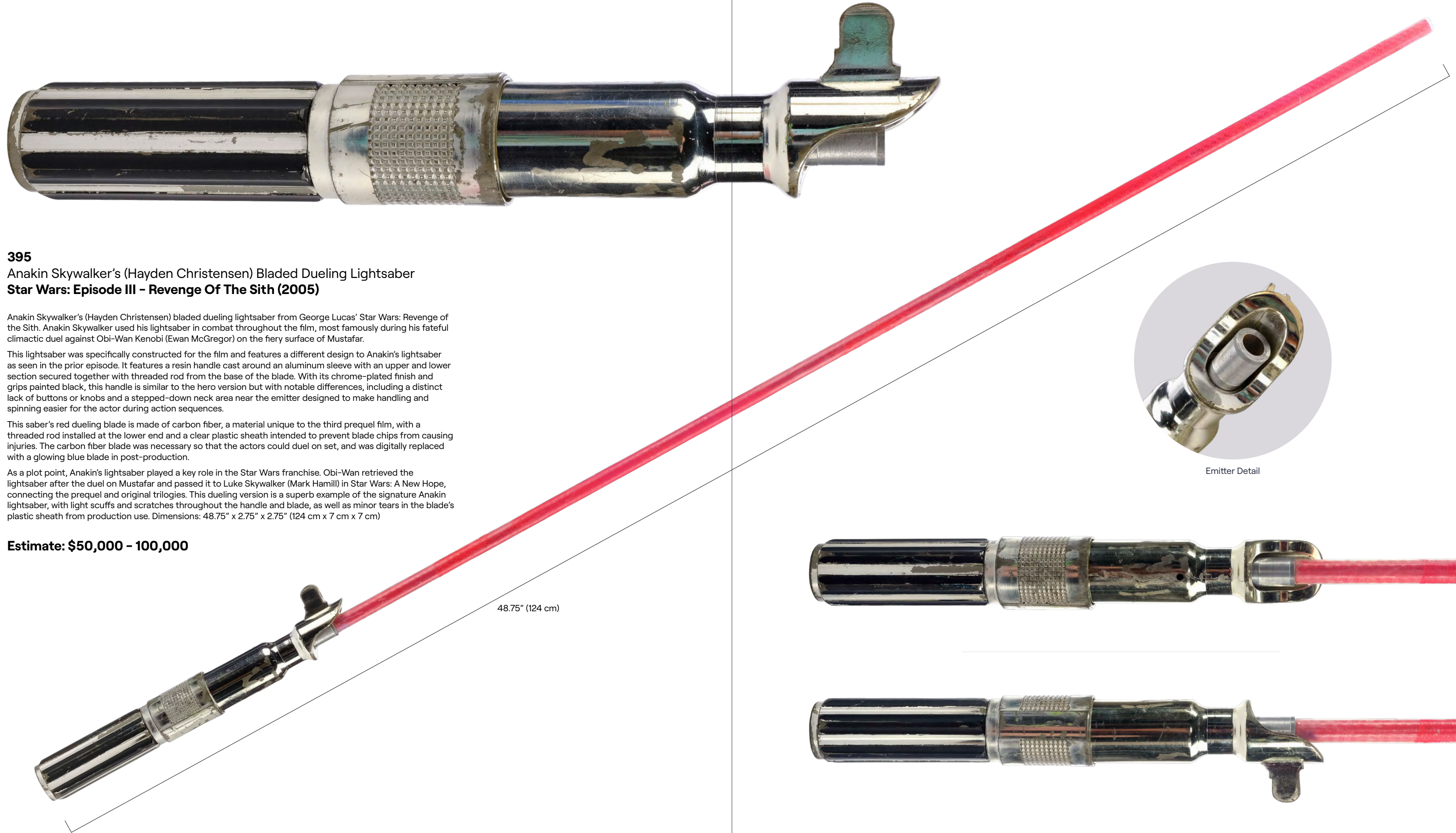

**395**  
**Anakin Skywalker's (Hayden Christensen) Bladed Dueling Lightsaber**  
**Star Wars: Episode III - Revenge Of The Sith (2005)**

Anakin Skywalker's (Hayden Christensen) bladed dueling lightsaber from George Lucas' Star Wars: Revenge of the Sith. Anakin Skywalker used his lightsaber in combat throughout the film, most famously during his fateful climactic duel against Obi-Wan Kenobi (Ewan McGregor) on the fiery surface of Mustafar.

This lightsaber was specifically constructed for the film and features a different design to Anakin's lightsaber as seen in the prior episode. It features a resin handle cast around an aluminum sleeve with an upper and lower section secured together with threaded rod from the base of the blade. With its chrome-plated finish and grips painted black, this handle is similar to the hero version but with notable differences, including a distinct lack of buttons or knobs and a stepped-down neck area near the emitter designed to make handling and spinning easier for the actor during action sequences.

This saber's red dueling blade is made of carbon fiber, a material unique to the third prequel film, with a threaded rod installed at the lower end and a clear plastic sheath intended to prevent blade chips from causing injuries. The carbon fiber blade was necessary so that the actors could duel on set, and was digitally replaced with a glowing blue blade in post-production.

As a plot point, Anakin's lightsaber played a key role in the Star Wars franchise. Obi-Wan retrieved the lightsaber after the duel on Mustafar and passed it to Luke Skywalker (Mark Hamill) in Star Wars: A New Hope, connecting the prequel and original trilogies. This dueling version is a superb example of the signature Anakin lightsaber, with light scuffs and scratches throughout the handle and blade, as well as minor tears in the blade's plastic sheath from production use. Dimensions: 48.75" x 2.75" x 2.75" (124 cm x 7 cm x 7 cm)

**Estimate: \$50,000 - 100,000**

48.75" (124 cm)



Emitter Detail



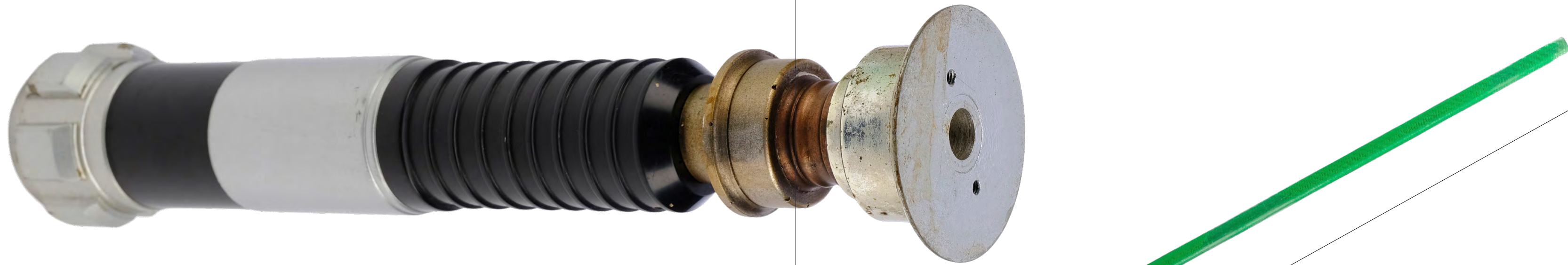

**396**  
**Obi-Wan Kenobi's (Ewan McGregor) Bladed Dueling Lightsaber**  
**Star Wars: Episode III - Revenge Of The Sith (2005)**

Obi-Wan Kenobi's (Ewan McGregor) bladed dueling lightsaber from George Lucas' Star Wars: Revenge of the Sith. Kenobi used his lightsaber in combat throughout the film, notably in a face-off with General Grievous and most famously during his fateful duel with Anakin Skywalker (Hayden Christensen) on the fiery surface of Mustafar.

The lightsaber was specifically constructed for the third prequel film and is a different design to Obi-Wan's lightsaber in the prior two Star Wars episodes. The handle is made of cast resin constructed around an aluminum sleeve. It consists of an upper and lower section that are secured together with the threaded rod from the base of the dueling blade. The resin handle features a multicolor finish, and a chrome-colored plated emitter and is similar to the hero version of the handle prop with some notable differences: a simplified grip, no lower control box, and a widened neck below the emitter for ease of handling while filming action sequences. Several different styles of fighting lightsaber handles were made for McGregor in varying degrees of simplicity to aid in handling for action sequences. The lightsaber's green blade is made of carbon fiber, a material unique to the third prequel film, with a threaded rod installed at the lower end and a clear plastic sheath intended to prevent blade chips from causing injuries. The carbon fiber blade was necessary so that the actors could duel on set, and was digitally replaced with a glowing blue blade during visual effects work.

As with Anakin Skywalker's lightsaber, this lightsaber design linked directly through to Star Wars: A New Hope where Alec Guinness appeared with a similar prop as an older Kenobi. The lightsaber exhibits wear from use, including scuffs and scratches throughout the handle and blade, discoloration on the emitter, and minor tears in the blade's plastic sheath. Dimensions: 48.75" x 2" x 2" (124 cm x 5.25 cm x 5.25 cm)

**Estimate: \$50,000 - 100,000**

48.75" (124 cm)





49.5" (125.75 cm)

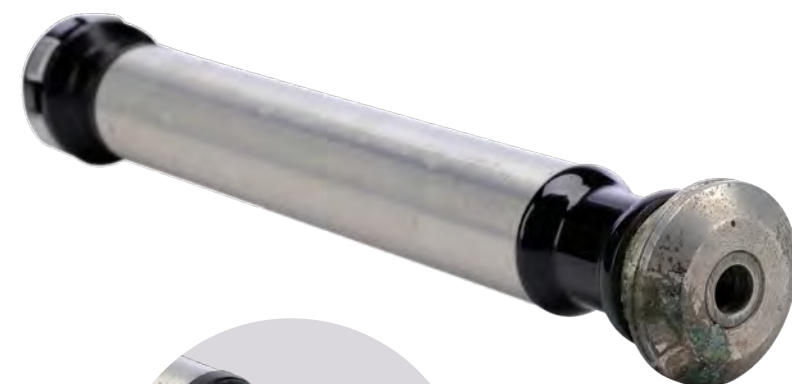

**397**  
Obi-Wan Kenobi's (Ewan McGregor)  
Rehearsal Lightsaber  
**Star Wars: Episode III - Revenge Of The Sith (2005)**

Obi-Wan Kenobi's (Ewan McGregor) rehearsal lightsaber from George Lucas' Star Wars: Revenge of the Sith. Jedi Master Obi-Wan wielded his signature blue lightsaber throughout the film.

This lot consists of a black and silver-color lightsaber hilt, a resin and metal handgrip, a rounded pommel cap inset with a threaded metal rod, and a carbon fiber blade painted green to be digitally overlaid with visual effects to produce its iconic blue glow. This rehearsal lightsaber's hilt is in the style carried by Kenobi in The Phantom Menace and Attack of the Clones, as it was originally planned for Kenobi to transition to his A New Hope hilt mid-film, but it was ultimately decided to instead have Kenobi wield his updated lightsaber from the beginning of the film. The hilt and blade exhibit nicking and scuffing throughout from production and handling. Dimensions: 49.5" x 2" x 2" (125.75 cm x 5.25 cm x 5.25 cm)

**Estimate: \$12,000 - 24,000**

**398**  
Nick Gillard Collection:  
Personal Storyboard Binder  
**Star Wars: Episode III - Revenge Of The Sith (2005)**

Nick Gillard's personal storyboard binder from the production of George Lucas' Star Wars: Episode III - Revenge of the Sith. This lot comes from the collection of celebrated stunt coordinator and sword master Nick Gillard. These storyboards were created specifically to be shown to Ewan McGregor and were flown out to him in North Carolina by Gillard.

The black binder features Gillard's name handwritten in white pen on its front cover and holds 120 printed pages protected in clear plastic sleeves. These pages detail the first versions of digitally rendered storyboards for almost the entire film and include short descriptions and the names and animated icons of the characters included in each shot. Dimensions: 12.5" x 11" x 2.25" (31.5 cm x 28 cm x 5.5 cm)

**Estimate: \$2,000 - 4,000**



# THE LORNE PETERSON COLLECTION

Renowned visual effects artist Lorne Peterson was born in 1944 in Vancouver, Canada. While designing whimsical playground equipment for McDonald's, Peterson was invited by fellow model maker John Dykstra to work in the miniature and optical effects department of George Lucas' Star Wars: A New Hope, where he helped design and build the Star Destroyers, Imperial TIE fighters, and other classic vehicles. During pre-production on the film, Peterson, Dykstra, and their cohort of fellow artists working under Lucas co-founded effects company Industrial Light & Magic. In later years, ILM would provide groundbreaking visual effects for many of the most successful franchises in the history of American cinema, including Star Wars, Back to the Future, and Ghostbusters, among many others.

As ILM's chief model maker, Peterson's models were instrumental to the successes of the first six Star Wars films, as well as a variety of other blockbuster hits, including Jurassic Park, Hulk, and his former ILM colleague Joe Johnston's own Jumanji. In 1985, Peterson and fellow ILM artists Dennis Muren, Michael J. McAlister, and George Gibbs received an Academy Award® for Best Visual Effects for their work on Indiana Jones and the Temple of Doom, one of several projects for director Steven Spielberg. In celebration of this pioneering 40-plus-year career, Propstore is proud to present a selection of key memorabilia from the personal collection of Lorne Peterson to the public for the first time.

**399**  
Lorne Peterson Collection:  
Hand-Painted Joe Johnston  
Forced Perspective Flat Endcap  
Painting for Three-Dimensional  
Death Star Trench Model  
**Star Wars: Episode IV - A New Hope (1977)**

A painting of the Death Star's trench endcap hand-painted by effects designer Joe Johnston for the production of George Lucas' Star Wars: A New Hope. TIE fighters chased Rebels through the dangerous trenches lining the surface of the Death Star.

This painting comes from the collection of miniature and optical effects unit model builder Lorne Peterson. It was created and cut by Johnston to be staged at the end of the massive Death Star model miniature set's trench in order to make the trench appear to extend into infinity through forced perspective.

To accomplish that, the painting was flat-painted in mixed media on particle board. A behind-the-scenes photo (not included) from supplemental materials for the film shows Johnston painting this exact endcap painting.

The painting is hand-marked "No. 2" in black marker on the reverse, and is believed to be only one of three endcaps made. It exhibits flaking paint, two punctures through its top corners, and edge wear throughout from production use. Dimensions: 40" x 30" (101.75 cm x 76.25 cm)

Sold without copyright; see notice in the Buyer's Guide.

**Estimate: \$25,000 - 50,000**



40" (101.75 cm)

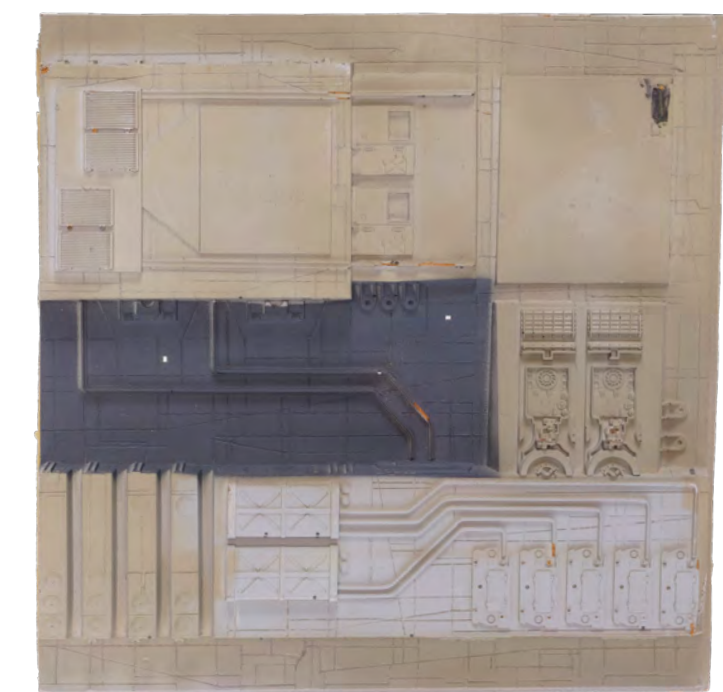

12" (30.5 cm)



**400**  
 Low-Altitude Death Star Model  
 Miniature Surface Panel  
**Star Wars: Episode IV - A New Hope (1977)**

A low-altitude Death Star model miniature surface panel from Star Wars: A New Hope. This piece was created as part of a miniature set of the Death Star's massive surface, specifically for low-altitude shots where fighters flew close to the station during the Rebel assault. Panels such as this were made in several different patterns, cast in bulk, then hand-painted and assembled to create the overall surface of the Death Star.

Designed and constructed by Industrial Light & Magic's (ILM) model miniature department, this dense foam panel with cast grid-like greeblies on top is hand-painted in shades of gray and applied with scotchlite reflective tape, indicating it may have been staged in the Death Star trench where reflective tape on various panels throughout filming. It also exhibits chipped paint. Dimensions: 12" x 12" x 1.25" (30.5 cm x 30.5 cm x 3.25 cm)

**Estimate: \$10,000 - 20,000**



7.5" (19 cm)

**401**  
 Lorne Peterson Collection: Lorne Peterson-  
 Autographed Death Star Gun Tower Model Miniature  
 with Attached Film Sticker  
**Star Wars: Episode IV - A New Hope (1977)**

A Death Star gun tower model miniature autographed by miniature and optical effects unit model builder Lorne Peterson with an attached film sticker from George Lucas' Star Wars: A New Hope. The Death Star's gun towers blasted at Rebel pilots targeting its reactor system.

This textured, dense foam gun tower comes from Peterson's collection. It is painted gray with plastic guns, autographed by Peterson in black marker on the underside, and affixed to the side with a color "The Star Wars" sticker. The sticker was applied by a model maker after filming before the tower was gifted to Peterson. This lot exhibits glue residue, grime, scratches, and fading paint. Dimensions: 3.5" x 4.5" x 7.5" (9 cm x 11.5 cm x 19 cm)

**Estimate: \$8,000 - 16,000**

**402**  
 Lorne Peterson Collection:  
 Lorne Peterson-Signed High-Altitude  
 Death Star Surface Model Miniature Panel  
**Star Wars: Episode IV - A New Hope (1977)**

A high-altitude Death Star surface model miniature panel from George Lucas' Star Wars: A New Hope signed by miniature and optical effects unit model builder Lorne Peterson. Industrial Light & Magic (ILM) designed and constructed this panel for the vast miniature Death Star set, specifically for shots where Rebel fighters flew close to its massive surface. Pieces of the set were later given out to attendees at the premiere of Star Wars: The Phantom Menace.

This biscuit foam panel comes from Peterson's collection. It is decorated with cast greeblies, finished in industrial gray paint, and signed on the underside in black marker by Peterson. The foam exhibits some scuffing and paint flaking from production use and age. Dimensions: 6.5" x 6.5" x 1" (16.5 cm x 16.5 cm x 2.5 cm)

**Estimate: \$4,000 - 8,000**

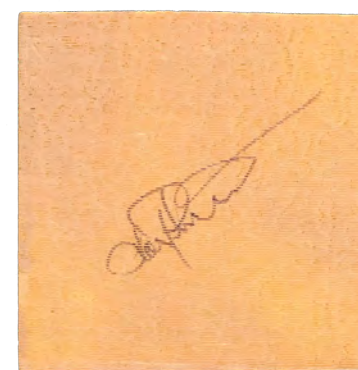

Underside Autograph

6.5" (16.5 cm)



**403**  
 High-Altitude Death Star  
 Surface Model Miniature Panel  
**Star Wars: Episode IV  
 - A New Hope (1977)**

A high-altitude Death Star surface model miniature panel from George Lucas' Star Wars: A New Hope. This panel was designed and constructed by Industrial Light & Magic (ILM) as part of the vast miniature Death Star set, specifically for shots where Rebel fighters flew high above its massive surface. Pieces of the set were later given out to attendees at the premiere of Star Wars: The Phantom Menace.

This biscuit foam panel is decorated with cast greeblies and finished in industrial gray paint with portions of white and yellow paint on the ends. Its underside is unpainted, and it exhibits some grime and flaking to the foam from production use and age. Dimensions: 6" x 3" x 1.25" (15.25 cm x 7.75 cm x 3 cm)

**Estimate: \$4,000 - 8,000**

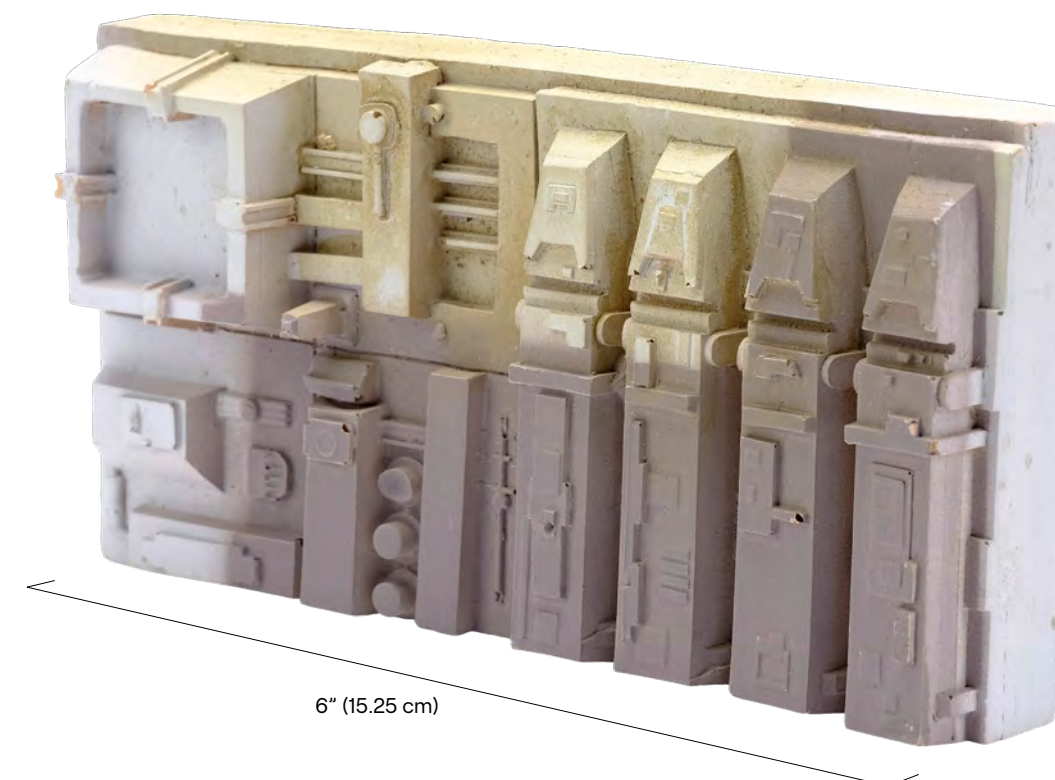

6" (15.25 cm)

**404****Princess Leia's (Carrie Fisher) Screen-Matched Ceremonial Dress  
Star Wars: Episode IV - A New Hope (1977)**

Princess Leia's (Carrie Fisher) original screen-matched ceremonial dress conceived by legendary costume designer John Mollo for George Lucas' *Star Wars: A New Hope*. Leia donned her gown during the film's final scene in the throne room where she graciously bestowed Luke Skywalker (Mark Hamill) and Han Solo (Harrison Ford) with their well-earned medals of honor. This historically significant piece is the only Princess Leia costume known to still exist from the original film.

The regal costume is symbolic of the princess' royal lineage and commanding presence. Like Leia's hooded dress from the film, the ceremonial gown was again crafted completely in white fabric. This was a deliberate choice on the part of creator Lucas to signify the purity and beauty of Leia's character. As Lucas wrote in the final scene of the film's original screenplay, "Luke, Threepio, Han and Chewbacca enter the huge ruins of the main temple. Hundreds of troops are lined up in neat rows. Banners are flying and at the far end stands a vision in white, the beautiful young Senator Leia. Leia is dressed in a long, white dress and is staggeringly beautiful."

Deborah Nadoolman Landis, former president of the motion picture Costume Designers Guild (CDG) and author of six books on the subject, points to the romantic, medieval style of the gown as a look that further solidifies Leia's rightful place as a leading character in the timeless epic. "If Luke's quest has been compared to King Arthur's, then Princess Leia is our Guinevere. With her crown of braided hair, Leia's romantic gown harkens back to Camelot with its glamorous long-hanging sleeves, narrow silhouette, and silver-armored girdle. Unmistakably Leia, it pairs perfectly with the high-necked white gown that serves the Alliance in the rest of the film. The simplicity and brilliance of John Mollo's costumes have staked a place in the iconography of costume design," Landis said.

Beyond its film use, the dress features on *Star Wars* posters including the original Style A one-sheet by Tom Jung and the Hildebrandts' artwork for the UK Quad. Fisher was shot by photographer David Steen for publicity photos in the dress, which were used as reference for these posters and have also been published in various other media.

Slightly more form-fitting and detailed than the costume she wore earlier in the film, this ceremonial dress is made from a cream lightweight silk fabric and includes intricate draping. It was fabricated by leading costume house Bermans and Nathans in conjunction with a French dressmaker. The costume features a hidden zipper along its side as well as hook-and-eye fasteners on the white shoulder. Unlike Leia's more conservative dress with a turtleneck collar, the ceremonial gown is distinguished by its empire-waist bodice, lower-cut neckline and unique integral sleeve drapery, all of which helped earn Mollo an Oscar® for Best Costume Design for *Star Wars* at the 50th annual Academy Awards in March 1978.

Once believed to no longer be in existence, this dress was stored for many years in a London attic. Upon its rediscovery, a meticulous, museum-caliber restoration was conducted by professional textile conservators in London. Over an eight-month period, the dress was thoroughly cleaned by hand to remove years of dust and dirt that had accumulated while in storage. The original structure of the garment was restored with archival precision. A conservation-grade gauze was adhered to the fabric in the most fragile areas, and tiny holes were infilled using the gauze as a base. The hem was restored in full and open seams were re-stitched. All work was carried out to top archival standards and is therefore fully reversible.

Costume designer Mollo stated later that he believed only a single ceremonial dress was created for the film, and there is no evidence to suggest otherwise. Details in the stitching of the dress, unique wrinkles and folds in the leather of the belt, and scratches on the belt's plates screen-match to the film and photo-match to publicity stills.

The dress is presented on a custom-made mannequin and is complete with the original belt, which is backed with a neutral material to prevent it from wearing on the dress while displayed. Also included are printed copies of contact sheets featuring David Steen's publicity photos of Fisher in the dress and the filming of the throne room scene.

The significance of the original Princess Leia Ceremonial Dress cannot be overstated. Considered globally to be a touchstone of modern entertainment, *Star Wars: A New Hope* has inspired generations worldwide. With the *Star Wars* IP now in the care of Disney, one of the world's top-entertainment companies, the characters and stories will undoubtedly be part of global culture for decades to come.

Like the film, Carrie Fisher is also considered a Hollywood mainstay. In her varied career, Fisher was nominated for an Emmy®, a Grammy®, a BAFTA®, and a Saturn Award®. As the daughter of Debbie Reynolds and Eddie Fisher, she is a cornerstone of American film history and forever linked to her most memorable character, Princess Leia. Fisher's sad passing in late 2016 brought a global outpouring of love from her fans. The 2017 *Star Wars* film *The Last Jedi* was dedicated to Fisher's memory, and she received a star on the Hollywood Walk of Fame in 2023.

**Estimate: \$1,000,000 - 2,000,000**

[Click here](#) to see separate booklet on this lot for additional photos and information.







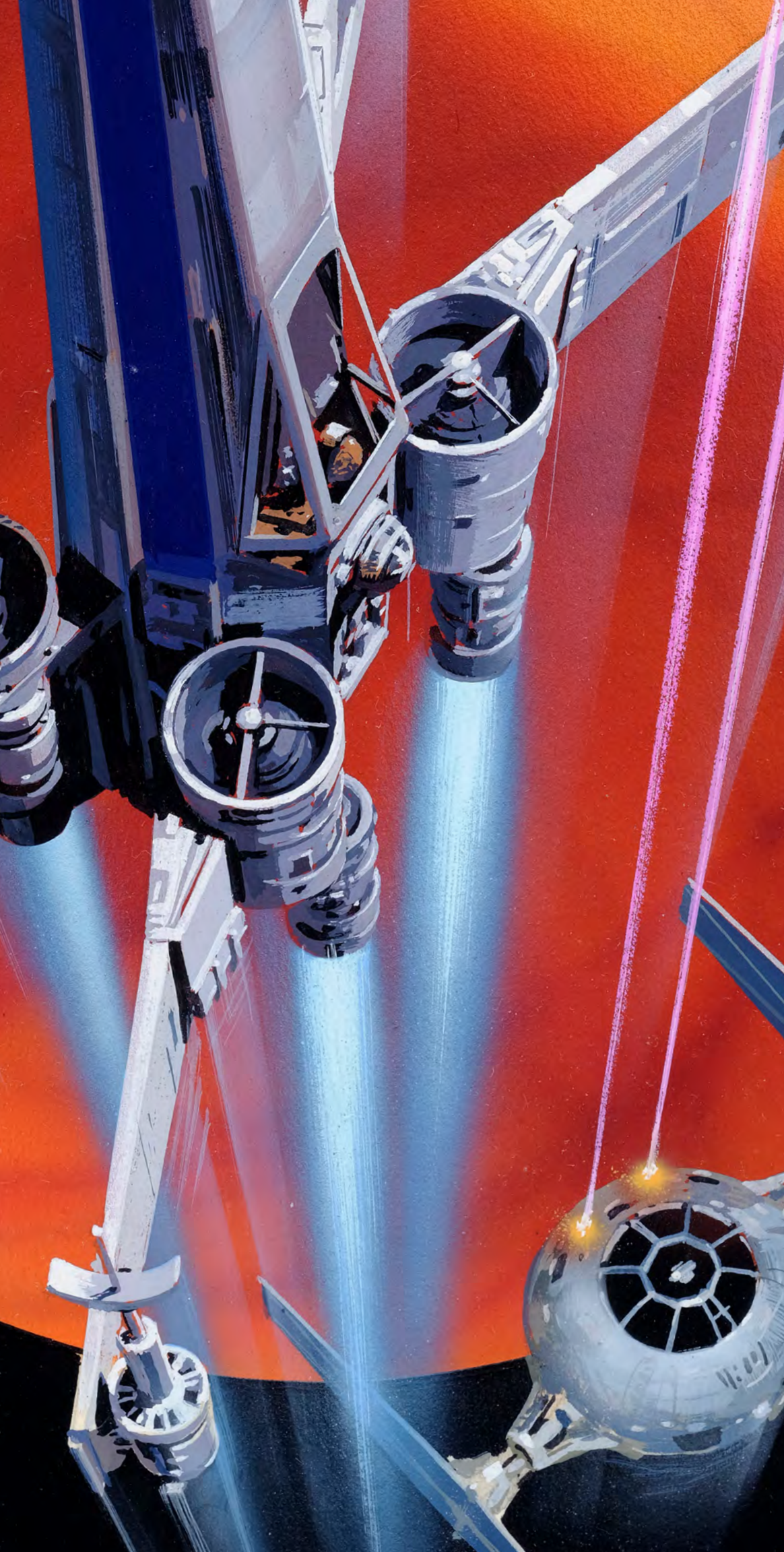

**405**  
 Hand-Painted Ralph McQuarrie  
 X-Wing Starfighter and Imperial  
 TIE Fighter Illustration  
**Star Wars: Episode IV**  
**- A New Hope (1977)**

An illustration of an X-wing starfighter and an Imperial TIE fighter hand-painted by Ralph McQuarrie from the production of George Lucas' *Star Wars: A New Hope*. This artwork was created circa August 1976, and later printed on T-shirts for US-based crew members, including the staff at Industrial Light & Magic (ILM). The ships in the artwork were likely a deliberate choice by McQuarrie to represent ILM's work.

This illustration is one of the few produced for the film that includes an X-wing. It is shown here in its final design form with four distinct engines rather than two, and features the earlier blue-striped fuselage which progressed to a red stripe later in production. The piece features a number of McQuarrie's signatures, including the orange planet in the background (similar to the well-known triangular "The Star Wars" logo McQuarrie designed), the arched framing (similar to the "Fantastic Five" painting), a soft gradient on the lettering, and airbrushed engine, laser, and motion streaks to add energy to the piece.

This illustration is rendered in mixed media, primarily including gouache, on illustration board. Below the "Star Wars" lettering is a pasted-on additional piece of paper likely added to cover an earlier abandoned design element. The board also features press-on lettering reading "the star wars corp. 1976." The artwork is stored with a clear acetate cover layer and an additional paper cover that McQuarrie applied after completing it. It remains extremely well-preserved with no fading and only a minor surface tear outside of the image area.

McQuarrie's original trilogy paintings are the pinnacle of his work; they are exceedingly rare and highly sought after by collectors. This is one of only a small number of McQuarrie paintings related to the first film known to exist in private collections today. Both the composition and content of the piece are superb, and a high-quality image of this artwork has never been published previously. Dimensions (on board): 16.5" x 19.25" x 0.75" (42 cm x 48.75 cm x 2 cm)

**Estimate: \$50,000 - 100,000**



© the star wars corp. 1976



**406**  
 Framed Hand-Painted Hildebrandt Brothers  
 1977 Collectors Edition Magazine Cantina Painting  
**Star Wars: Episode IV - A New Hope (1977)**

A cantina painting hand-painted by the Hildebrandt Brothers for the 1977 Marvel Star Wars Official Collectors Edition Magazine released as a promotional tie-in with George Lucas' Star Wars: A New Hope. Art by the brothers Greg and Tim Hildebrandt was used throughout the promotion of A New Hope, making them fan favorites of the franchise.

This original full-color painting of the cantina scene is rendered in mixed media on wood-framed canvas and signed "Hildebrandt" in red on the right side. Also included is a copy of the 1977 Marvel Star Wars Official Collectors Edition Magazine, the UK-only version of what was published as The Star Wars Album in the US. This lot has undergone sympathetic repair, and exhibits a build-up of grime from age and exposure with a crack in the frame. Dimensions: 24" x 19.5" x 2" (61 cm x 49.5 cm x 5 cm)

Sold without copyright; see notice in the Buyer's Guide.

**Estimate: \$15,000 - 30,000**



Hildebrandt Cantina painting as printed in the  
 Marvel Star Wars Official Collectors Edition Magazine (1977)



**407**  
 Matted Hand-Illustrated Harry  
 Lange Millennium Falcon Cockpit Concept Collage  
**Star Wars: Episode IV - A New Hope (1977)**

A concept collage of the Millennium Falcon's cockpit assembled and hand-illustrated by pioneering designer and concept artist Harry Lange for the production of George Lucas' Star Wars: A New Hope. Han Solo (Harrison Ford) piloted the Falcon, originally called the Pirate Ship in Lucas' early script, throughout the film.

This lot comes from the collection of Harry Lange. Lange was known for doing detailed panels with many switches, buttons, lights and pinlines. He created various panels of similar designs for 2001: A Space Odyssey, Moonraker, Superman, and others.

This collage consists of cardboard cutouts of a figure and paneling hand-illustrated in mixed media to resemble a mechanical interior, all mounted in a circle to backing board. Also mounted below them are a black-and-white still of the Falcon's cockpit and a label hand-marked "Star Wars Millennium Falcon Int. Cockpit." The collage comes framed behind plastic with white matte board. The collage exhibits minor staining throughout. Dimensions: 20" x 21.5" x 0.25" (51 cm x 54.75 cm x 0.75 cm)

Sold without copyright; see notice in the Buyer's Guide.

**Estimate: \$6,000 - 12,000**



Autograph Detail

**408**  
 Matted Hand-Drawn Harry Lange  
 Landspeeder Design Artwork  
**Star Wars: Episode IV  
 - A New Hope (1977)**

Matted landspeeder design artwork hand-drawn by pioneering designer and concept artist Harry Lange for the production of George Lucas' Star Wars: A New Hope. V-35 landspeeders floated through the desert streets of Mos Eisley and the Lars family kept one in the garage at their homestead.

This lot comes from the collection of Harry Lange. This artwork depicting bird's eye, front, and side views of a landspeeder is rendered in graphite and ink and labeled "Speeder II 1:10 Build on Existing Structure" on bordered paper. It comes framed behind plastic with white matte board. The paper exhibits crinkling, fold lines, and minor staining throughout from production. Dimensions: 32" x 44" (81.5 cm x 111.75 cm)

Sold without copyright; see notice in the Buyer's Guide.

**Estimate: \$5,000 - 10,000**

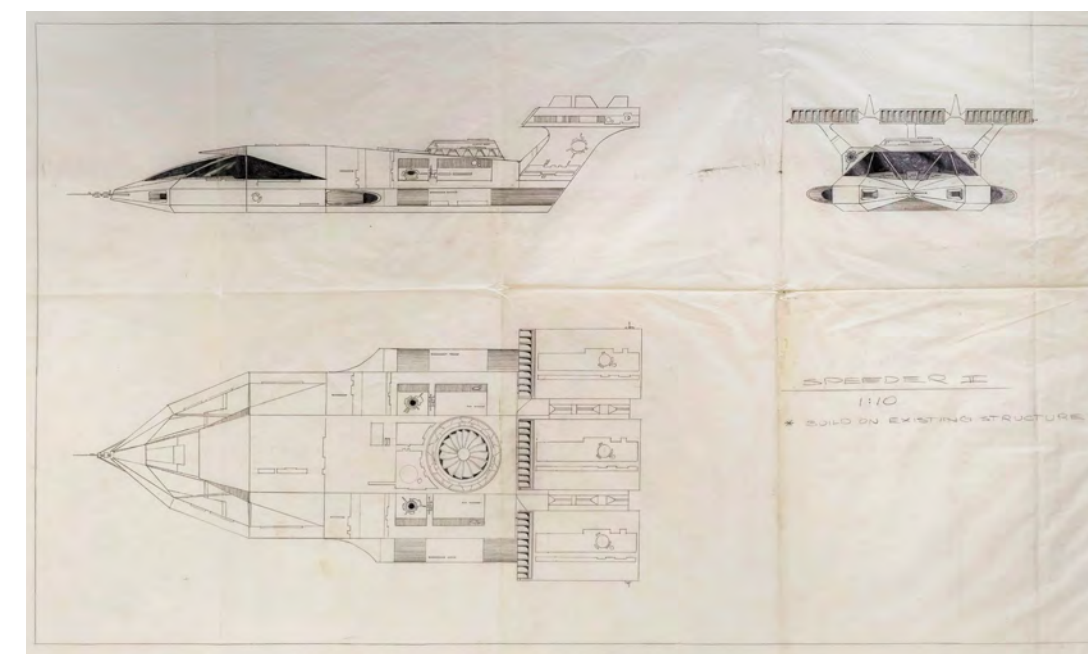

(image darkened for readability)

**409**  
**Robert Blalack's**  
**Praxis Optical Printer**  
**Used to Composite Every VFX Shot**  
**Star Wars: Episode IV**  
**- A New Hope (1977)**

The original "Praxis" optical printer used in 1976 and 1977 at Industrial Light & Magic (ILM) to composite every visual effects shot in Star Wars: A New Hope. Robert Blalack, whose company name was Praxis, was an integral part of the VFX team for the groundbreaking film and earned an Academy Award® for his contributions. As part of his deal, Blalack rented his personal optical printer to the facility; ILM proceeded to invest heavily in improving, or "hot rodding," the printer to achieve the effects. Beyond the equipment, Blalack solved the critical problem of organizing the VistaVision compositing workflow that was incredibly challenging in the pre-digital age.

Blalack acquired the Praxis printer before Star Wars. When he finished on the film, he retained the printer and subsequently used it on numerous other projects, including Blues Brothers, Airplane!, RoboCop, and more. Blalack can be seen operating his optical printer two minutes into [David Berry's 5757](#), a behind-the-scenes "home movie" shot at ILM during production on A New Hope: <https://vimeo.com/5494280>.

This printer consists of a camera, two projectors, and a lamp housing, which allow various film elements to be composited into a single shot. While some components have been upgraded or modified in the time since Star Wars (such as the lamp housing), much of it remains original and in good overall condition, though the printer is currently non-optical. Also included are the original wooden magazine, an electronic control panel believed to post-date Star Wars (though other wiring elements are no longer present), and various other small components. The printer's base is a converted lathe bed, as the printer had to be rock-solid so as to not vibrate during precision compositing work.

The original Star Wars changed filmmaking forever, and this printer was a core and pivotal tool in the work accomplished at Industrial Light & Magic. The historic Praxis printer and the work of Robert Blalack are well-known to visual effects aficionados and represent the major leap forward in technology and process achieved at ILM. Dimensions: 148" x 68" x 30" (376 cm x 173 cm x 76.5 cm)

Contains electronics and mechanical components; see notice in the Buyer's Guide.

Special shipping required; see notice in the Buyer's Guide.

**Estimate: \$50,000 - 100,000**

148" (395.72 cm)

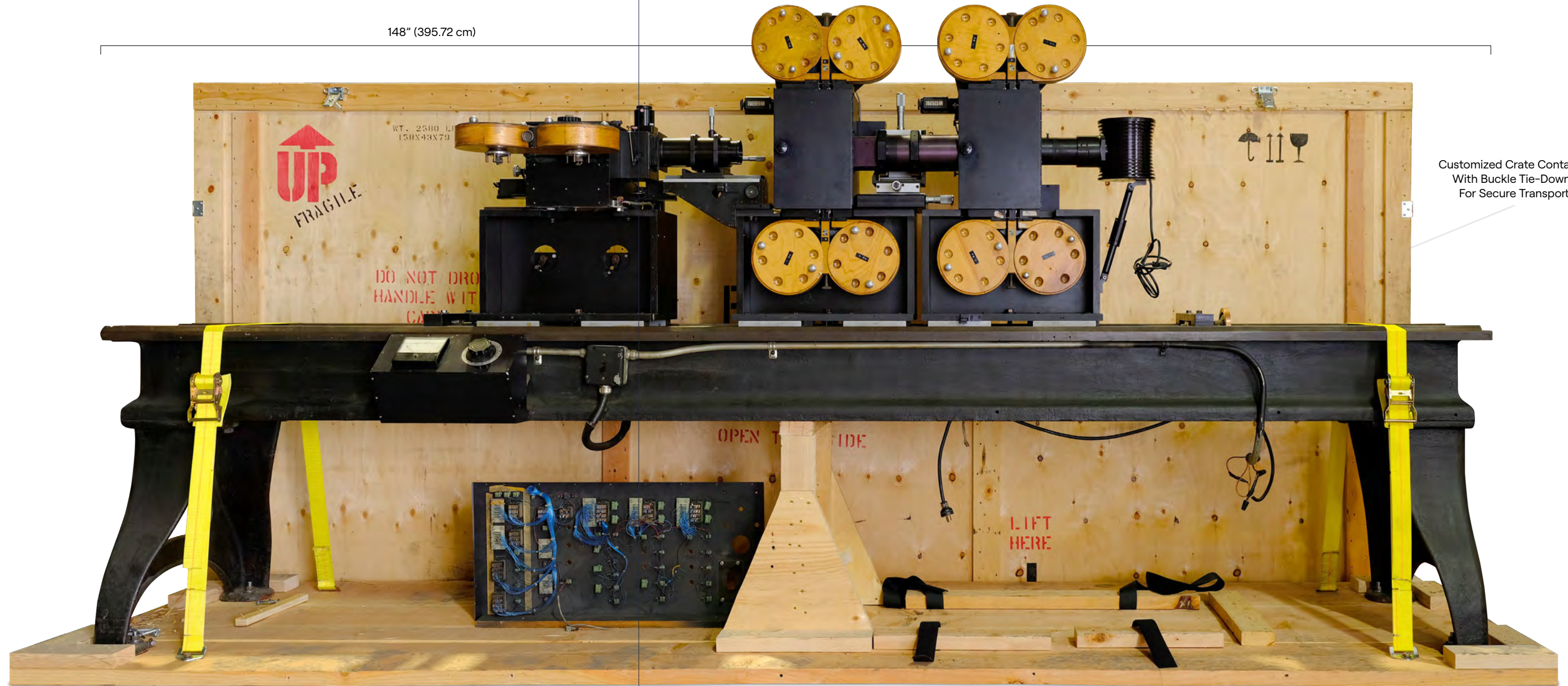

Customized Crate Container  
 With Buckle Tie-Downs  
 For Secure Transport



Praxis Serial Number Plaque



Control Panel Detail

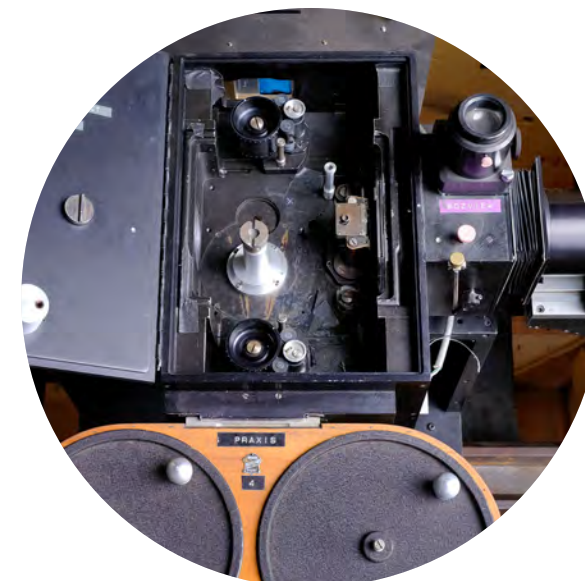

Camera Interior Detail

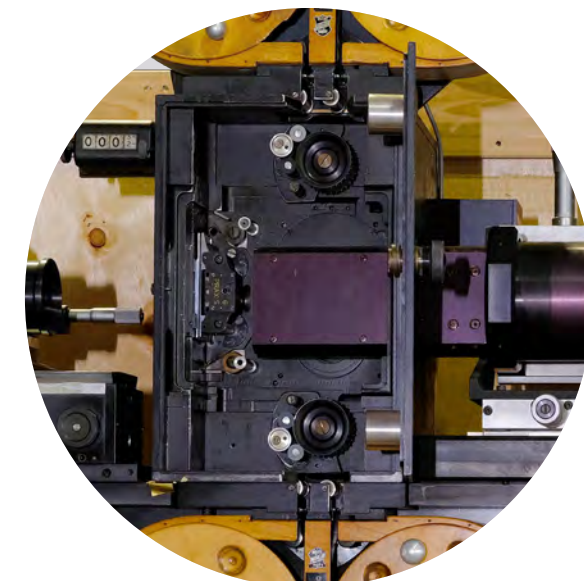

Projector Interior Detail

# MODEL MAKER DAVE JONES COLLECTION

Born September 22, 1947, renowned model maker David "Dave" Jones contributed groundbreaking visual effects to some of the most successful and beloved films in world history before his death in April 2022. After starting out as a model builder on George Lucas' *Star Wars: A New Hope*, Jones created special photographic effects and worked as a consultant on several other popular Industrial Light & Magic (ILM) projects, including *Close Encounters of the Third Kind* and *Buck Rogers in the 25th Century*. In the 1990s, he became the model shop supervisor for Richard Edlund's *Boss Film Studios*, where he oversaw award-winning effects work for visionary films such as *Alien 3*, *Outbreak*, and *Starship Troopers*, among many others. Now, Propstore is proud to offer one-of-a-kind memorabilia from The Dave Jones Collection to the public for the first time. Spanning four decades of work in Hollywood, these rare lots reflect only a small piece of Jones' singular impact on cinema history.



## 410 Dave Jones Collection: Exploded Pyrotechnic X-Wing Fuselage Model Miniature Components *Star Wars: Episode IV - A New Hope* (1977)

A set of exploded pyrotechnic X-Wing fuselage model miniature components from George Lucas' *Star Wars: A New Hope*. This remnant originated from an exploded model used during the film's groundbreaking battle sequences.

This lot comes from the collection of veteran model maker Dave Jones. It exemplifies Industrial Light & Magic's (ILM) ad-hoc creation of cruder models sans paintwork given that they needed more models than originally planned. While high-quality, fully-finished model miniatures for pyrotechnical work were planned, necessity and logic lead to the creation of lower-quality models, given that these would not be fully-realized in photography prior to their destruction. As such, this lot features a foam fuselage with five small plastic "kitbashed" components in a gray speckled paint and fine mechanical detail. The fuselage sans its red striping, like other cruder pyro models that appear in the film, exhibits damage from production, with a melted side and a burned top hull. This lot exhibits fragility from deliberate scoring for spark visibility and to aid its breaking apart, hot glue remnants from mounting, chipped paint, and discoloration. Dimensions: 12" x 3" x 2.5" (30.5 cm x 7.75 cm x 6.5 cm)

**Estimate: \$8,000 - 16,000**

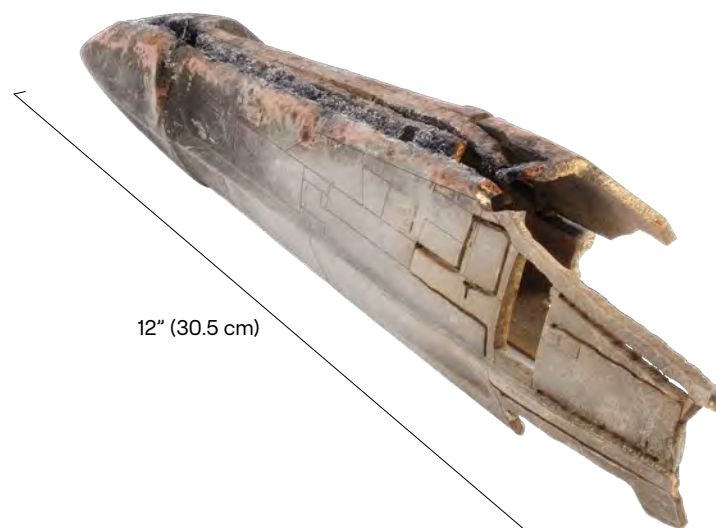

## 411 Dave Jones Collection: Exploded Pyrotechnic Y-Wing Model Miniature Components *Star Wars: Episode IV - A New Hope* (1977)

A set of exploded pyrotechnic Y-Wing model miniature components from George Lucas' *Star Wars: A New Hope*. This remnant originated from an exploded model used during the film's groundbreaking battle sequences.

This set comes from the collection of veteran model maker Dave Jones. Made of foam, these components consist of a large piece of ship hull, a smaller piece of hull, and one small wing structure fragment. A "kitbashed" laser cannon is also included. Finished in a gray speckled paint, these components feature fine mechanical details. The larger hull piece features a production-applied wire. As these components were designed for pyrotechnical effects, this lot exhibits notable damage from production. This lot exhibits chipped paint and discoloration. Dimensions: 4" x 3" x 2" (10.25 cm x 7.75 cm x 5 cm)

**Estimate: \$2,000 - 4,000**

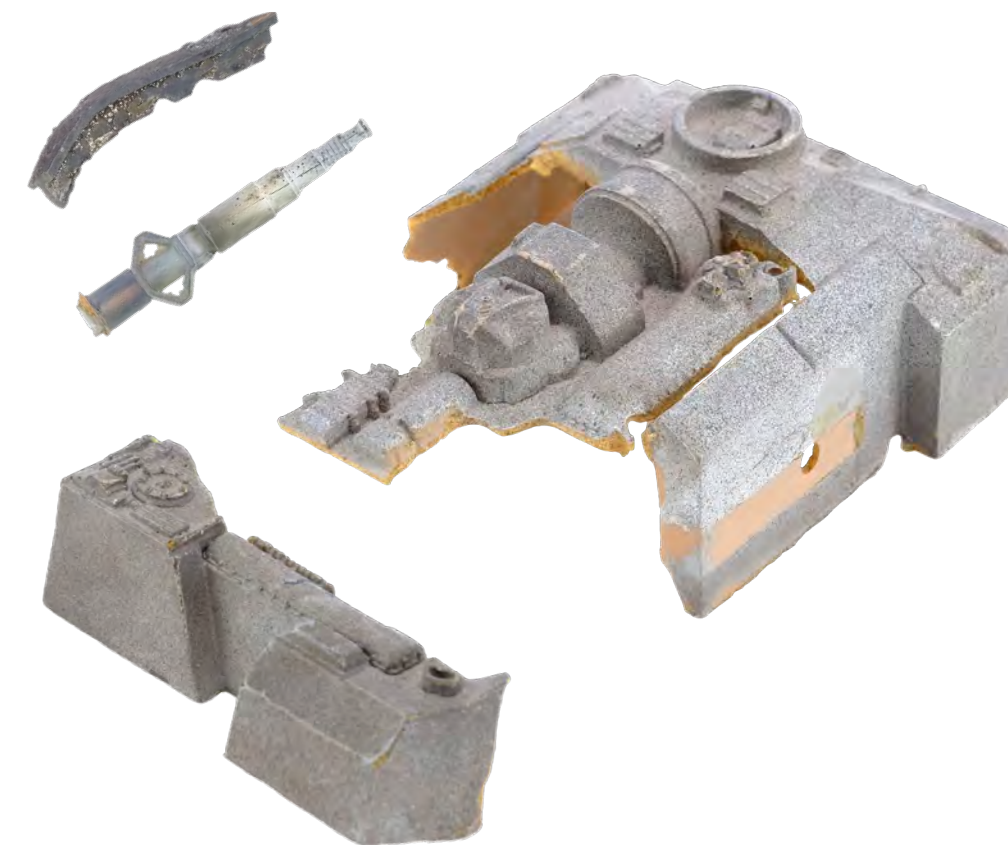

## 412 Dave Jones Collection: Exploded Pyrotechnic TIE Fighter Wing Structure Component *Star Wars: Episode IV - A New Hope* (1977)

An exploded pyrotechnic TIE Fighter wing structure component from George Lucas' *Star Wars: A New Hope*. This remnant originated from an exploded model used during the film's groundbreaking battle sequences.

This lot comes from the collection of veteran model maker Dave Jones. Made of foam, this component consists of an incomplete section of the solar array support frame. Finished in a gray paint, this component features fine mechanical details and six prongs. As these components were designed for pyrotechnical effects, this lot exhibits notable damage from production, including broken spokes and a split through the center. This lot exhibits chipping, notable marks, and foam fragility. Dimensions: 13" x 10" x 1" (33 cm x 25.5 cm x 2.5 cm)

**Estimate: \$2,500 - 5,000**

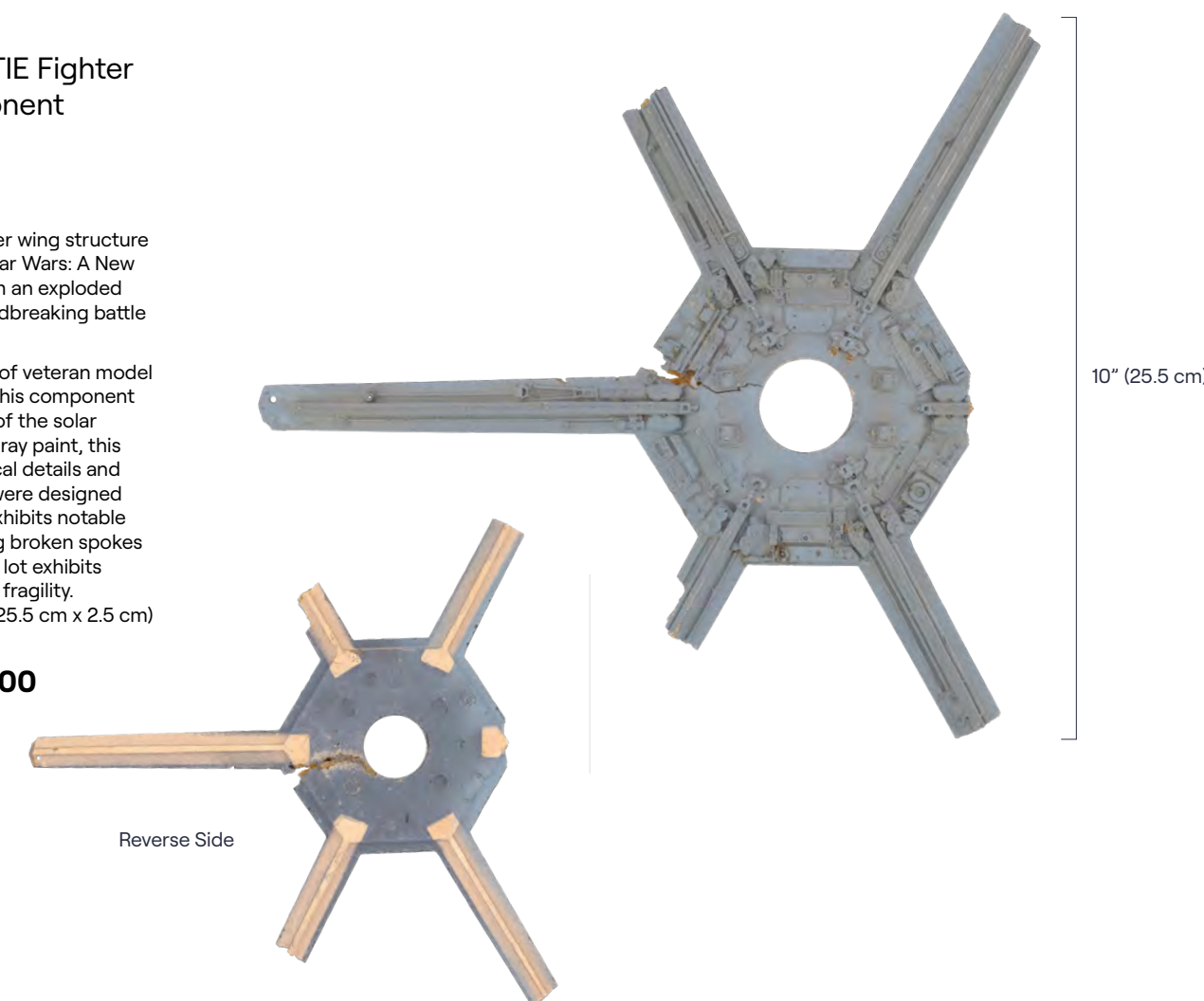

Reverse Side

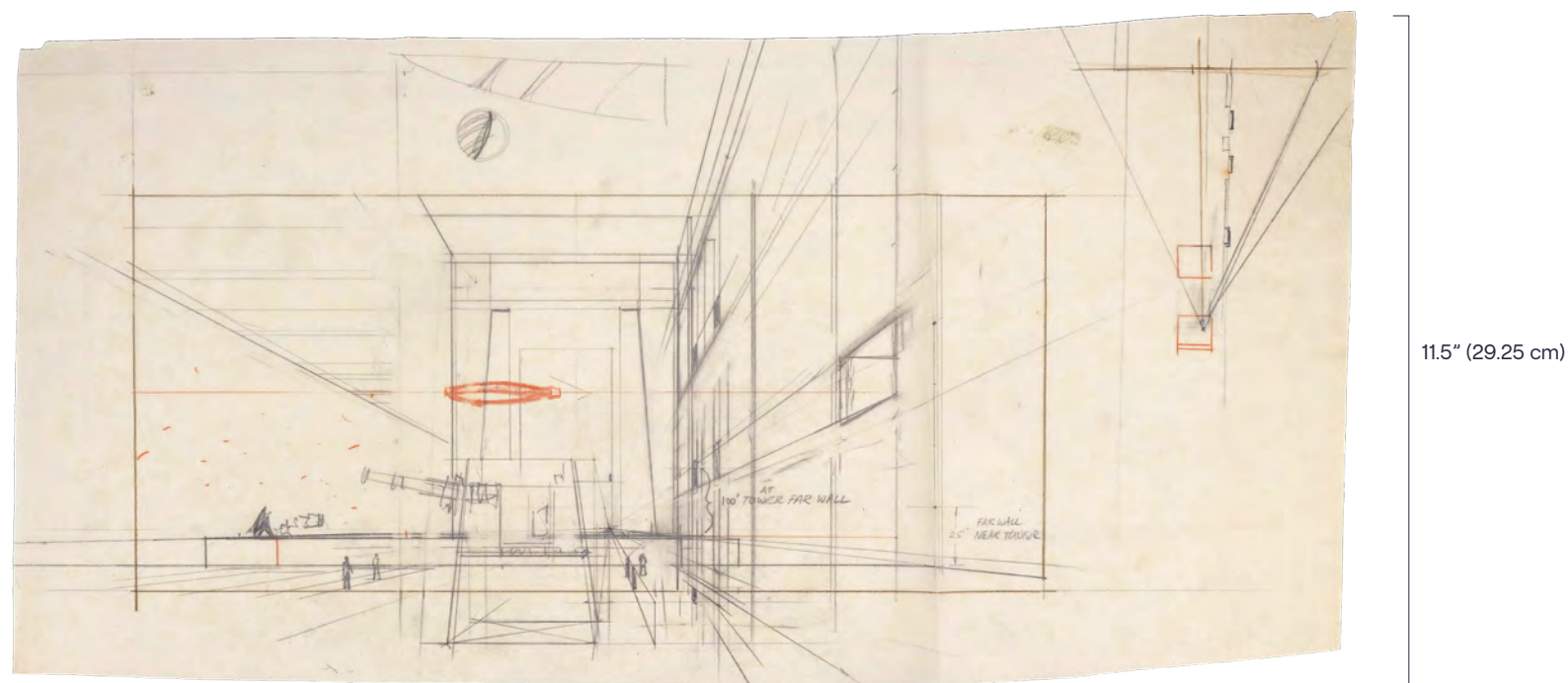

11.5" (29.25 cm)

**413**  
 Hand-Drawn Ralph McQuarrie  
 "Death Star Docking Trench #2" Matte Concept Sketch  
 Star Wars: Episode IV - A New Hope (1977)

A concept sketch hand-drawn by production illustrator Ralph McQuarrie for his matte painting study illustration "Death Star Docking Trench #2" from the production of George Lucas' Star Wars: A New Hope. McQuarrie painted the final matte painting based on the "Docking Trench #2" illustration circa December 1976.

This concept sketch depicting the Millennium Falcon entering the Death Star and labeled "at 100' tower far wall" is rendered in graphite and orange pencil on vellum. It is also featured on page 150 of the Abrams publication Star Wars Art: Ralph McQuarrie. The vellum exhibits some yellowing from age and minor edge wear. Dimensions: 16" x 11.5" (40.75 cm x 29.25 cm)

Sold without copyright; see notice in the Buyer's Guide.

**Estimate: \$8,000 - 16,000**

**414**  
 Matted Printed Joe Johnston  
 Tantive IV Production Dyeline  
 Star Wars: Episode IV  
 - A New Hope (1977)

A matted and printed Joe Johnston dyeline of the Tantive IV from the production of George Lucas' Star Wars: A New Hope. C-3PO (Anthony Daniels) and R2-D2 (Kenny Baker) fled the Rebel's blockade runner, Tantive IV, with stolen plans for the Galactic Empire's Death Star.

This dyeline is a printed copy of a drawing of Tantive IV rendered by Industrial Light & Magic (ILM) visual effects artist Johnston and used for reference for the construction of VFX model miniatures during production. It comes framed behind plastic with white matte board. The dyeline exhibits some discoloration, liquid streaks, and several stray illustrations. Dimensions: 32" x 44" (81.5 cm x 111.75 cm)

**Estimate: \$5,000 - 10,000**

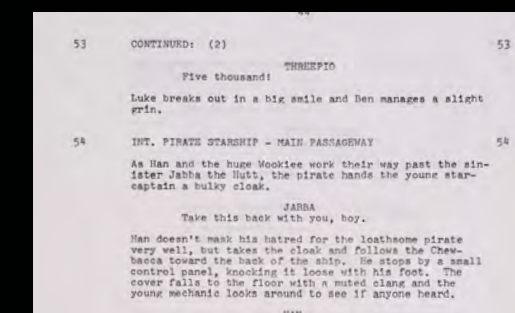
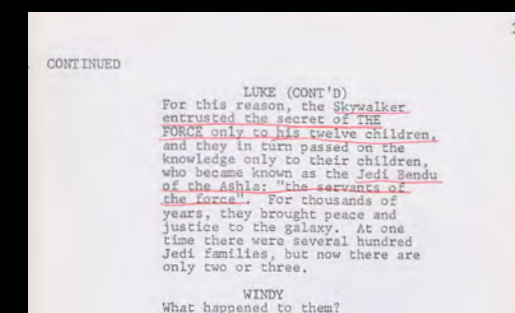
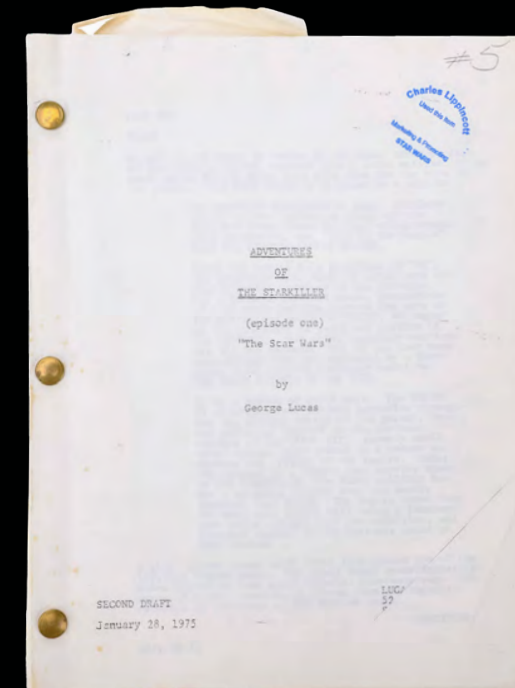
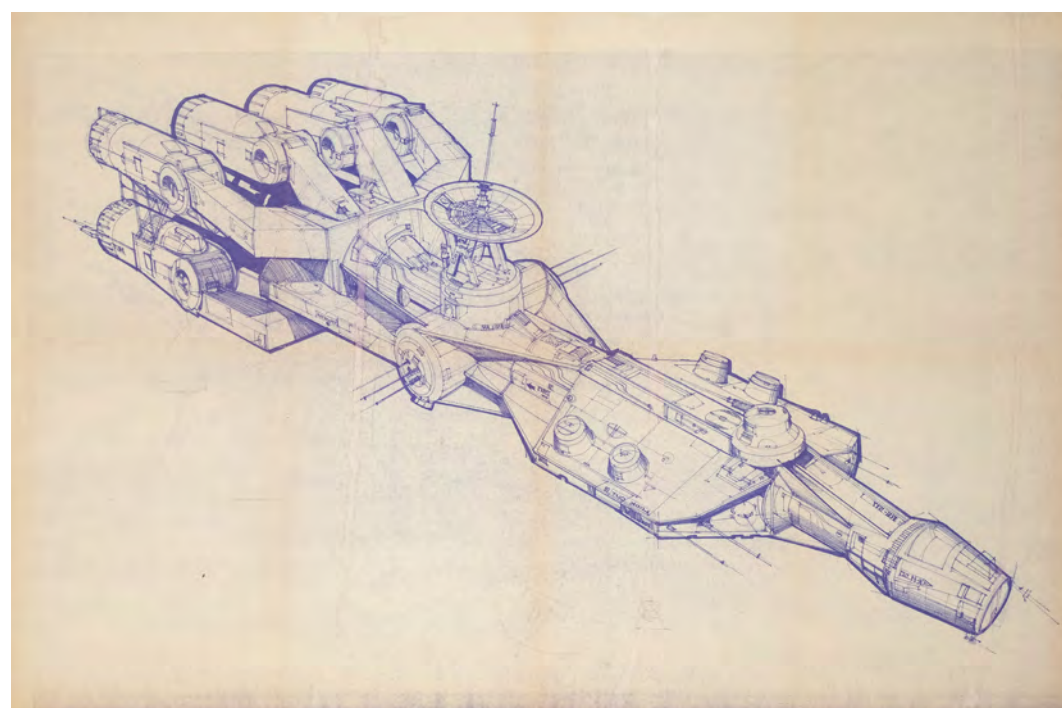

**415**  
 Charles Lippincott Collection:  
 Production-Used  
 "Adventures of the Starkiller"  
 Second Draft Screenplay  
 Star Wars: Episode IV  
 - A New Hope (1977)

A production-used "Adventures of the Starkiller" second draft screenplay from George Lucas' Star Wars: A New Hope. This screenplay worked as an early draft of the film before it became Star Wars: A New Hope.

This lot comes from the collection of the film's advertising and publicity supervisor Charles "Charley" Lippincott. This 118-page second draft is dated January 28, 1975, and features an official "Charles Lippincott" stamp on the front cover in blue ink. It is marked "#5" and has hand-written notes and markings in red pen with two pages marked using paper tabs. The screenplay exhibits stains and fold creases from storage and age. Dimensions: 8.5" x 11" x 0.5" (21.75 cm x 28 cm x 1.5 cm)

**Estimate: \$6,000 - 12,000**

**416**  
 Production-Made  
 Third Draft Screenplay Copy  
 Star Wars: Episode IV  
 - A New Hope (1977)

A production-made third draft screenplay copy from George Lucas' Star Wars: A New Hope. This 110-page screenplay is dated "August 1, 1975" and was written by George Lucas.

Printed on white paper, this third revision screenplay is titled "The Star Wars" and is "from the Adventure of Luke Starkiller." It also features a hand-written "58" on the cover beneath the right upper corner in black ink. This lot exhibits some notable discoloration on the upper right corner and some minor edgewear. Dimensions: 8.5" x 12" x 1" (21.5 cm x 30.5 cm x 2.5 cm)

**Estimate: \$6,000 - 12,000**



14" (35.75 cm)



**417**  
 Hand-Drawn Tom Jung  
 Luke and Leia Sketch  
 Star Wars: Episode IV  
 - A New Hope (1977)

A Luke and Leia sketch for George Lucas' Star Wars: A New Hope hand-drawn by posterist Tom Jung. Commissioned by Smith, Smollen & Connelly to create a one-sheet for the film, Jung created the iconic Style "A" one-sheets distributed by 20th Century Fox.

This sketch originated from Jung's personal collection and was previously offered at auction in 2012, however it should be noted that the piece's exact date of creation remains unknown. It is rendered in graphite on Hammermill illustration paper and signed by Jung. The sketch exhibits bending, wear along the bottom edge, and minor stains throughout. Dimensions: 14" x 17" (35.75 cm x 43.25 cm)

Sold without copyright; see notice in the Buyer's Guide.

**Estimate: \$7,000 - 14,000**



**418**  
**Panavision PSR (Panavision Silent Reflex) 35mm Motion Picture Camera**  
**Various Productions**

A Panavision PSR (Panavision Silent Reflex) 35mm motion picture camera manufactured circa 1960s and utilized on many productions throughout its history. The PSR camera was Panavision's first custom-made camera system and quickly became a staple of the movie industry. Panavision built the PSRs around existing Mitchell camera internals, placing the Mitchell interiors into custom-made Panavision blimps and applying superior engineering to systems for optics, lenses, and other crucial parts of operation.

PSR cameras were used extensively on major motion pictures in the U.S. and abroad from their introduction in the late 1960s until circa the 1980s. Many fan-favorite films were shot on PSRs, including *The Wild Bunch*, *Butch Cassidy and The Sundance Kid*, *Alien*, *Superman: The Movie*, *Star Wars: A New Hope* and *The Empire Strikes Back*, and countless others. Panavision only rented its equipment to productions and never sold it, though it did have distribution deals with a number of overseas partners such as Samuelsons in the U.K., who supplied Panavision equipment into major European productions.

After the PSR, Panavision developed the Panaflex camera system, which was lighter weight and easier to work with on location. PSR cameras became studio cameras for films, and in the 1990s were commonly used as pedestal-mounted cameras for shooting sitcoms.

Only a small number of PSR cameras (perhaps less than 60) were ever manufactured, unlike Panaflex cameras, which were manufactured in greater quantities. Many PSR cameras were converted circa late-1980s and 1990s into "Super PSR" units with additional electronics, a revised motor system, and controls on the back. This PSR is in its original unconverted condition, matching the appearance seen in stills from behind the scenes of *A New Hope* and other films of the era. However, the magazine blimp which sits atop its body is engraved with the Super PSR text (including "R-200," a reference to the 200-degree angle of the shutter.)

While the specific history of this camera and the productions it worked on are unknown, it may have been on any number of countless films and represents one of the great motion picture camera systems of the past 100 years. Panavision cameras are exceedingly rare and the PSR is considered one of the finest. Its current functionality remains untested but it is believed to be in operational condition. Also included are a 100mm Panavision lens with follow-focus system; a swing-out Panavision matte box; an early-style round motor cover for a non-crystal motor; a Mitchell non-crystal motor; a yellow Panavision power cable; a 35mm film magazine; and transport cases for both the camera and magazine. The set is well cared for and remains in excellent overall condition with minor wear to the camera body and lens. Dimensions: 26.5" x 17" x 14" (67.5 cm x 43.25 cm x 35.5 cm)

Contains electronics and mechanical components; see notice in the Buyer's Guide.

Special shipping required; see notice in the Buyer's Guide.

**Estimate: \$40,000 - 80,000**



Matte Box



Lens Detail



Movement Detail



**419**  
 Don Post Studios Limited Edition Light-Up R2-D2  
 Statue Display  
**Star Wars: Episode IV - A New Hope (1977)**

A limited edition light-up R2-D2 statue display based on George Lucas' Star Wars: A New Hope. Created by the legendary Don Post Studios in 1998, full-size statues were modeled closely on original components from the Lucasfilm Archive.

This statue is made of fiberglass, with some metal embellishments and braided copper-color hosing attached around the feet. The dome includes multiple lights which are activated via a switch on a wired plug made for a U.S. outlet. The droid is presented on its original gray display base, which features a Don Post presentation plaque marked with the number "042." The statue exhibits light wear, including signs of sympathetic repair where a small vent flap had previously broken off. Dimensions: (displayed) 48" x 40" x 37" (122 cm x 101.75 cm x 94 cm)

Contains electronics; see electronics notice in the Buyer's Guide.

**Estimate: \$10,000 - 20,000**



48" (122 cm)



**420**  
 Replica Darth Vader (David Prowse)  
 Lightsaber Hilt Made From Real-World Components  
**Star Wars: Episode IV - A New Hope (1977)**

A replica Darth Vader (David Prowse) lightsaber hilt made using the real-world components as used for George Lucas' Star Wars: A New Hope. Many of the props in the first Star Wars film, especially the lightsaber hilts, were created using found objects creatively combined together.

This lightsaber consists of the metal handle of a Micro Precision Products (MPP) 3-cell microflash with an original MPP clamp and replica shroud, attached black plastic T-track segments as grips, and a switch plate made from a calculator display. Of note, the red LED in the clamp is one of two Vader saber variations seen in the film. The finish exhibits some scratching from the age of the components the lightsaber is built from. Dimensions: 11" x 2.5" x 2.5" (28 cm x 6.5 cm x 6.5 cm)

**Estimate: \$5,000 - 10,000**



**421**  
 C-3PO's (Anthony Daniels)  
 Left Foot  
**Star Wars: The Empire Strikes Back (1980)/Star Wars: Return Of The Jedi (1983)**

A C-3PO's (Anthony Daniels) left foot from the second and third installments of George Lucas's Star Wars trilogy, The Empire Strikes Back and Return of the Jedi. Daniels wore metallic gold-color feet as part of C-3PO's distinctive costume throughout the films as he aided the Rebel Alliance in their struggle to free the galaxy from the evil Galactic Empire.

C-3PO's costume evolved throughout the films, and this shoe style was created and used for the films that followed A New Hope. During that first production, the feet were fashioned with a fiberglass or vacuum-formed foot cover, which clipped over a canvas deck shoe worn underneath. This was upgraded in the sequels to a fully soled rubber foot cast around the actor's shoes. This rubber left foot is covered in metallic gold-color vinyl and features a back split for the foot and shoe to slide in. The vinyl finish exhibits scuffing and cracking, and in some areas, mainly around the ankle and the sole, the gold-color has faded to a silver-color or worn away, revealing the rubber beneath. Dimensions: 11.25" x 4.5" x 4" (28.5 cm x 11.5 cm x 10.25 cm)

**Estimate: \$9,000 - 18,000**



12" (30.5 cm)

**422**  
 Lorne Peterson Collection:  
 Scratch-Built Prototype Executor Model Miniature  
**Star Wars: Episode V - The Empire Strikes Back (1980)**

A scratch-built prototype Executor model miniature from Irvin Kershner's Star Wars: The Empire Strikes Back. The Executor served as Darth Vader's (David Prowse) commanding ship as it attacked the Rebel Alliance's Echo Base in the Battle of Hoth.

Made as a proof-of-concept for George Lucas' approval, this model miniature comes from the collection of miniature and optical effects unit chief model maker Lorne Peterson. It is constructed of thin white polyurethane with light gray-painted polyurethane details on the top and back, two thin white foam board inserts, and graphite-marked tape sections. This model miniature exhibits notable loss of adhesion on the tape, cuts from production, and grime and discoloration from age. Dimensions: 12" x 4" x 1.5" (30.5 cm x 10.25 cm x 4 cm)

**Estimate: \$10,000 - 20,000**

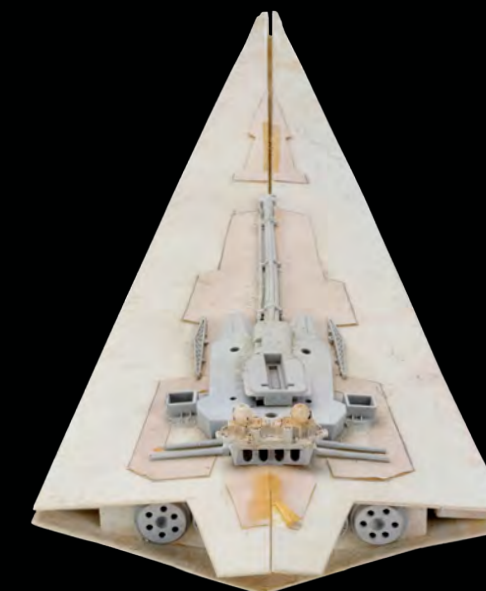

**423**  
 Lorne Peterson Collection:  
 Screen-Matched  
 Asteroid Model Miniature  
**Star Wars: Episode V**  
**- The Empire Strikes Back (1980)**

A screen-matched asteroid model miniature from Irvin Kershner's *Star Wars: The Empire Strikes Back*. This asteroid screen-matches to multiple shots of the asteroid field Han Solo (Harrison Ford) piloted the Millennium Falcon into to hide from Imperial forces after the Falcon's hyperdrive malfunctioned.

This lot comes from the collection of miniature and optical effects unit chief model maker Lorne Peterson. One of four asteroids of this scale known to remain from production, this miniature is made of hard-coated yellow foam painted gray and brown to simulate stone. The bottom features holes in a triangle-shape from the trident-shaped prongs used to mount the models during filming. It exhibits some chipping throughout the finish. Dimensions: 12.5" x 10.5 x 7" (31.75 cm x 26.75 cm x 18 cm)

**Estimate: \$20,000 - 40,000**



Topps Widevision Star Wars:  
 The Empire Strikes Back Card (1995)



10.5" (26.75 cm)





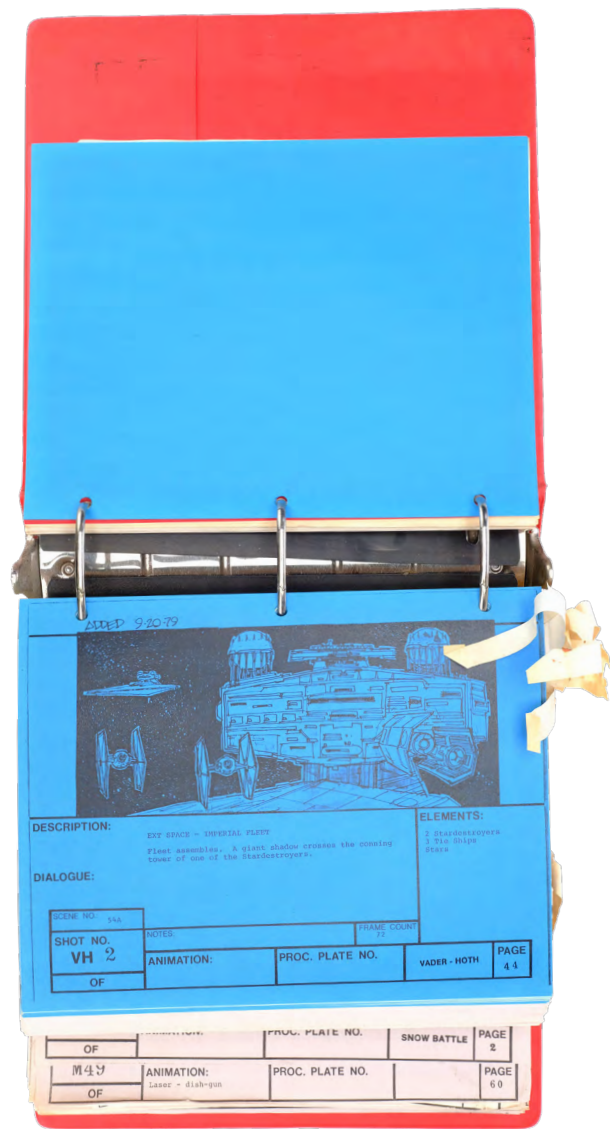

**424**  
Lorne Peterson Collection: VFX Storyboard Binder  
**Star Wars: Episode V - The Empire Strikes Back (1980)**

A VFX storyboard binder from Irvin Kershner's Star Wars: The Empire Strikes Back. This red storyboard binder comes from the collection of miniature and optical effects unit chief model maker Lorne Peterson. It is labeled "Copy #11 Storyboards Issue 2 Model Shop" and "LORNE" along the spine, top and bottom edges, makeshift paper tabs, and a note on the front handwritten "TO: LORNE PETERSON ILM FROM: DEBBIE FINE." The binder contains 540 pages of storyboards printed on red, blue, pink, yellow, white, orange, and green paper; smaller storyboards on half pages; laminated index pages. This lot exhibits grime on the exterior from age, creases along the pages' edges, and sticking pages. Dimensions: 11" x 11.5" x 4" (28 cm x 29.25 cm x 10.25 cm)

**Estimate: \$6,000 - 12,000**

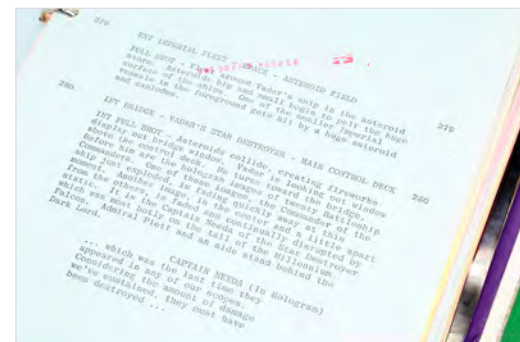
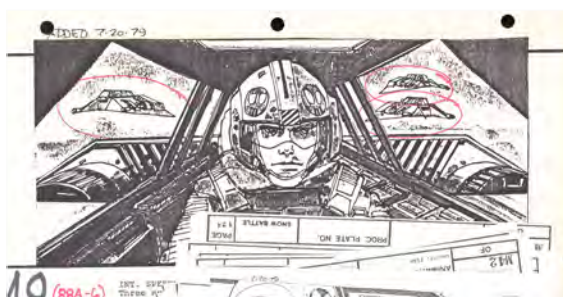

**425**  
Set Decorator Michael Ford's Production-Used  
Screenplay with Extensive Annotations and Breakdowns  
**Star Wars: Episode V - The Empire Strikes Back (1980)**

Set decorator Michael Ford's extensively hand-annotated screenplay with prop and set dec breakdowns from the production of Irvin Kershner's Star Wars: The Empire Strikes Back.

This lot includes numerous never-before-seen materials from the production contained in a 221-page green vinyl binder. The paperwork consists of a script with extensive highlights and handwritten annotations; typed correspondences from production supervisor Bruce Sharman and property master Frank Bruton to Ford; a Norwegian location prop list featuring photo-copied illustrations; production-printed storyboards; and production-printed black-and-white photo references among various other production ephemera. The set exhibits discoloration and minor stains from age. Dimensions: 9.75" x 13.5" x 1.5" (25 cm x 34.5 cm x 4 cm)

**Estimate: \$5,000 - 10,000**

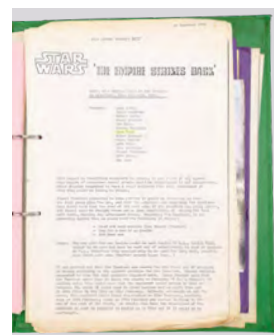

**426**  
Unproduced Lando Calrissian  
Large Size Action Figure Outfit  
**Star Wars: Episode V - The Empire Strikes Back (1980)**

An unproduced Lando Calrissian large size action figure's outfit from Kenner's Star Wars line. Though seen in early promotional photography for toys to be released in conjunction with Irvin Kershner's Star Wars: The Empire Strikes Back, the Lando Calrissian large size action figure was ultimately never produced. As such, an extremely low number of outfits for the figure are known to exist.

This outfit consists of a sky-blue fabric tunic with black detailing on the collar and cuffs and matching cloth trousers. It comes dressed on a headless production Han Solo action figure with black rubber boots added to complete the display. The outfit exhibits some staining on the collar and sleeves. Dimensions: 2.5" x 4.5" x 11" (6.25 cm x 11.25 cm x 27.5 cm)

**Estimate: \$20,000 - 40,000**



11" (27.5 cm)



**427**  
**Rebel Trooper Blaster**  
**Star Wars: Episode VI - Return Of The Jedi (1983)**

A Rebel trooper blaster made for the production of Star Wars: Return of the Jedi. Rebel soldiers were seen with silver-tipped blasters in both Star Wars: A New Hope and Star Wars: The Empire Strikes Back. This blaster, commonly known as the BlasTech DH-17 blaster pistol, was created for Return of the Jedi and intended to be used for filming, but ultimately did not appear in the film. A similar Return of the Jedi rebel soldier blaster was documented in pre-production photography during prep.

The blaster is built on a replica Sterling submachine gun. It is primarily metal and has been modified by the production team to feature futuristic dressing such as the custom-machined silver-color flash suppressor, the greeblies dressed on either side, a cut-down magazine, and a single-point scope mounted on a rod scope rail.

While never seen on film in Jedi, the rebel blasters are well known amongst Star Wars fans due to their use in the prior Star Wars films. The blaster exhibits some wear from use and age, including scuffing, paint loss, and chipping to the front of the scope. Dimensions: 17" x 9" x 4" (43.25 cm x 23 cm x 10.25 cm)

**Estimate: \$16,000 - 32,000**



**428**  
**Production-Made Lando Calrissian (Billy Dee Williams)**  
**Skiff Guard Helmet**  
**Star Wars: Episode VI - Return Of The Jedi (1983)**

A Lando Calrissian (Billy Dee Williams) skiff guard helmet made for the production of Richard Marquand's Star Wars: Return of the Jedi. Calrissian disguised himself as one of Jabba the Hutt's skiff guards to help rescue Han Solo (Harrison Ford) from the Pit of Sarlacc.

This helmet is constructed from black vacuum-formed plastic with a ridged purple leatherette cover secured to the dome with brass-color metal studs and a brown and white resin face mask featuring pointed teeth wrapped with leatherette cord. The mask is missing a bottom fang, the interior exhibits some adhesive residue, and the helmet exhibits scratching throughout from production wear and handling. Dimensions: 15" x 15" x 19" (38.25 cm x 38.25 cm x 48.5 cm)

**Estimate: \$12,000 - 24,000**



6" (15.25 cm)

**429**  
 Stuart Ziff Collection: Sarlacc Tooth  
**Star Wars: Episode VI**  
**- Return Of The Jedi (1983)**

A sarlacc tooth from Richard Marquand's Star Wars: Return of the Jedi. Jabba the Hutt sentenced Luke Skywalker (Mark Hamill) and his friends to die by being cast into the Great Pit of Carkoon, where the sarlacc digested its victims over 1,000 years.

This foam tooth comes from the collection of chief articulation engineer Stuart Ziff. Constructed by Industrial Light & Magic (ILM) for the sarlacc's cavernous fanged mouth, it is applied with a thin urethane skin and painted in shades of red and brown. The foam is rigid due to age, and some of the urethane and paint exhibits cracking, exposing the unpainted beneath. Dimensions: 6" x 1" x 1" (15.25 cm x 2.5 cm x 2.5 cm)

**Estimate: \$2,500 - 5,000**



**430**  
 Stuart Ziff Collection: Jabba the Hutt Courtier Cup  
 with Ree-Yees ROTJ 65B Figure  
**Star Wars: Episode VI - Return Of The Jedi (1983)**

A Jabba the Hutt courtier cup from Richard Marquand's Star Wars: Return of the Jedi with a Ree-Yees ROTJ 65B figure from Kenner's Return of the Jedi toy line. Jabba the Hutt's courtiers, such as Ree-Yees, drank from their cups while watching the attempted execution of Luke Skywalker (Mark Hamill) aboard Jabba the Hutt's sail barge.

This lot comes from the collection of chief articulation engineer Stuart Ziff. It consists of a white plastic cup with abstract designs in a raised gold-color adhesive and a hole in the bottom with a small piece of pipe adhered to it. The figure features a punched cardback with a price sticker and an image of Ree-Yees with his mug. The mug exhibits scuffing and wear to the applied design, and the figure exhibits corner denting to the cardback and a yellowed bubble. Dimensions: (largest) 9" x 9" x 2" (23 cm x 23 cm x 5.25 cm)

**Estimate: \$2,000 - 4,000**

**431**  
 "Revenge of the Jedi"  
 Makeup Department Sign Δ  
**Star Wars: Episode VI**  
**- Return Of The Jedi (1983)**

A makeup department sign from the production of Richard Marquand's Star Wars: Return of the Jedi, then-titled "Revenge of the Jedi." Various department signs created by production hung at Elstree Studios during filming.

This masonite sign features a white front with the title logo for "Revenge of the Jedi" in blue, the words "Make-Up Dept." in gray, and holes drilled into the top corners for hanging. It exhibits chipping along the edges, staining of the white front, fading of the lettering, and scuffing throughout. Dimensions: 11" x 27" x 0.75" (28 cm x 68.75 cm x 2 cm)

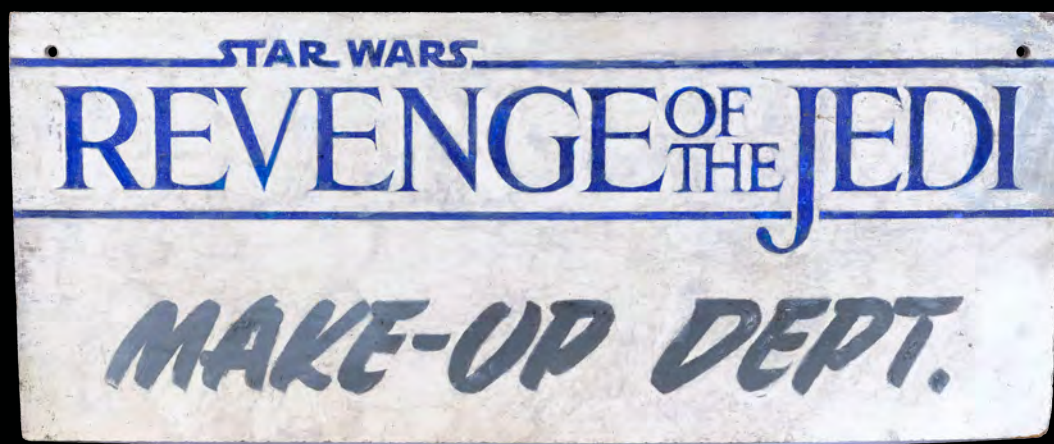

27" (68.75 cm)

**Estimate: \$8,000 - 16,000**

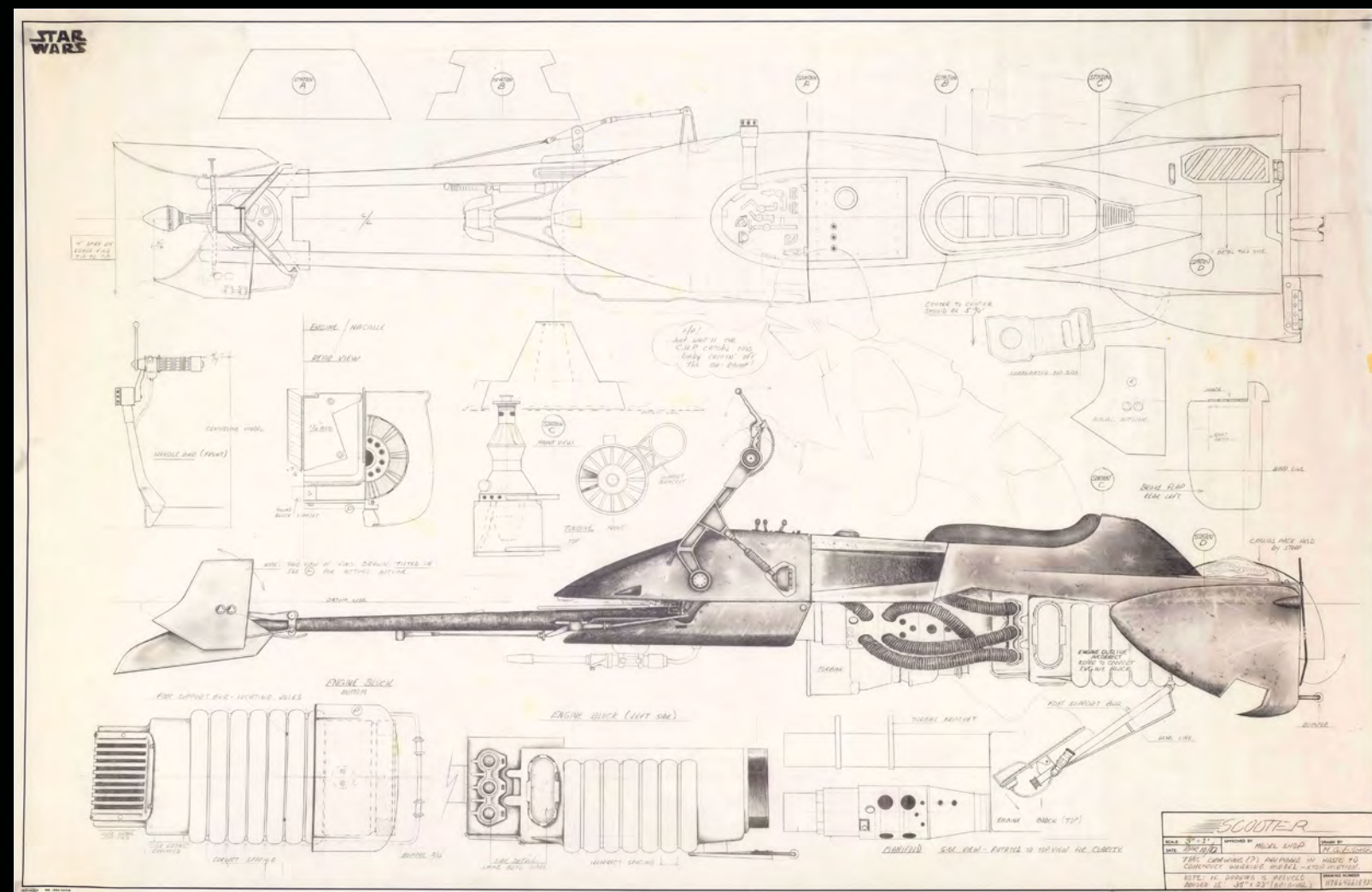

36" (91.5 cm)

**432**  
 Lorne Peterson Collection:  
 Hand-Drawn Michael Glenn Fulmer Speeder Bike Blueprint  
**Star Wars: Episode VI - Return Of The Jedi (1983)**

A speeder bike blueprint hand-drawn by visual effects chief model maker Michael Glenn Fulmer for the production of Richard Marquand's Star Wars: Return of the Jedi. Fulmer drew this blueprint to coordinate Industrial Light & Magic's (ILM) construction of the speeder bike models for the Endor chase sequence.

This blueprint depicting bird's eye and left side views of a speeder bike, as well as sketches of a Biker Scout and various components such as "Handle Bar," "Foot Support Bar," and "Engine Block," comes from the collection of ILM model shop supervisor Lorne Peterson. It is rendered and annotated in pencil on Star Wars-branded drafting paper labeled "Scooter," dated "Apr 10/82," numbered "1178646618925," and initialed "M.G. Fulmer." It exhibits staining and creasing from being rolled for storage. Dimensions: 36" x 23.75" (91.5 cm x 60.5 cm)

Sold without copyright; see notice in the Buyer's Guide.

**Estimate: \$10,000 - 20,000**

**433**  
George Lucas' Handwritten  
Acts II and III Outlines  
**Star Wars: Episode VI**  
**- Return Of The Jedi (1983)**

Outlines for Acts II and III from pre-production on Richard Marquand's Star Wars: Return of the Jedi. George Lucas hand wrote these outlines while still in the draft stage of his and Lawrence Kasdan's script.

This lot consists of two pages of U.S. legal-size lined paper respectively titled "Act II" and "Act III" with scene notes written in pencil below in Lucas' distinctive handwriting. The Act II page features scenes numbered "1" through "18" with such descriptive annotations as "Vader looking for Rebels" and "Luke lost - talks with Yoda," while the Act III page's scenes are numbered "1" through "16" with annotations such as "Vader and Luke fight" and "Celebration, dance." Both exhibit some discoloration and folding corners from age and handling. Dimensions: 8.5" x 14" (21.75 cm x 35.75 cm)

**Estimate: \$8,000 - 16,000**

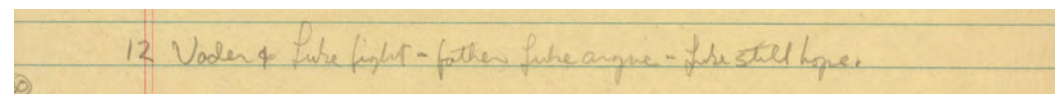
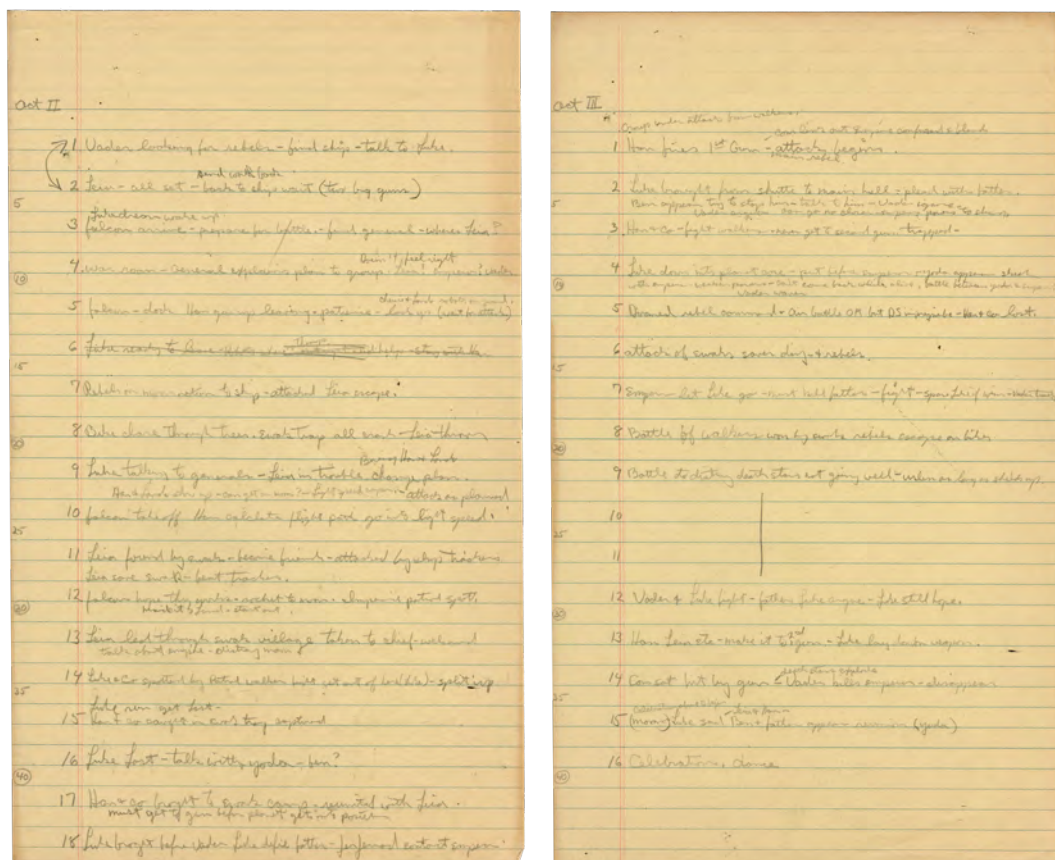

George Lucas Handwriting Detail

**434**  
Lorne Peterson Collection:  
VFX Storyboard Binder  
**Star Wars: Episode VI**  
**- Return Of The Jedi (1983)**

A VFX storyboard binder from Richard Marquand's Star Wars: Return of the Jedi. This red plastic storyboard binder comes from the collection of miniature and optical effects unit chief model maker Lorne Peterson. It contains 550 pages of storyboards, some with handwritten annotations, printed on red, blue, pink, yellow, white, orange, and green paper, as well as handwritten labels on various color tabs. The binder exhibits loose and sticking pages and grime. Dimensions: 11.5" x 11.5" x 3" (29.25 cm x 29.25 cm x 7.75 cm)

**Estimate: \$6,000 - 12,000**

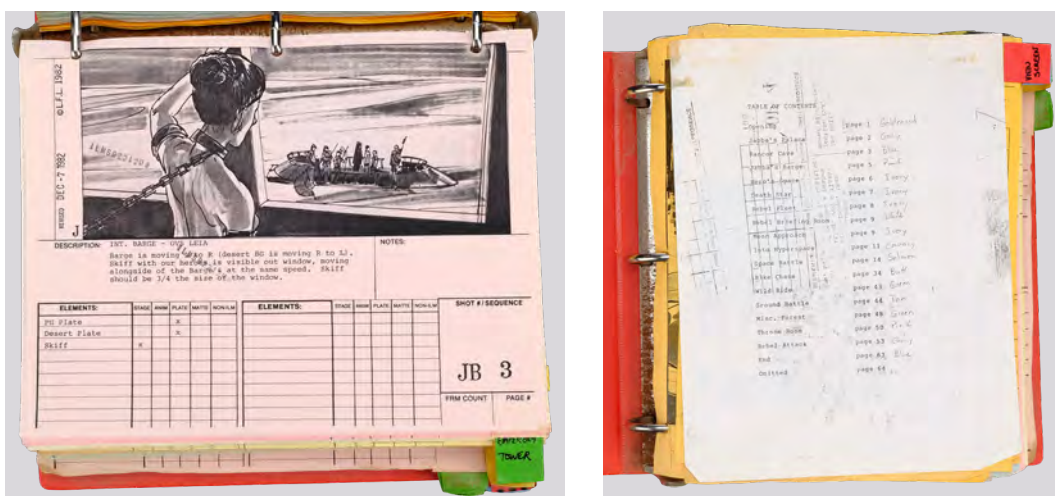

# WILLIAM PLUMB STAR WARS & SCIENCE FICTION ARTWORK COLLECTION

For the last four decades, William Plumb has been at the forefront of Star Wars and science fiction original art collecting. He was a pioneer in searching for artwork for his collection and began contacting artists to inquire about their works in the mid 1980s. Over time he developed personal relationships with many renowned artists including Ralph McQuarrie, Drew Struzan, Lawrence Noble, and Dave Dorman. In 1986, Plumb organized the "Space Fantasy & Reality Art Expo" at the Maturango Museum in Ridgecrest, California, to benefit the handicapped. The event was supported by contributions from Plumb's artist friends and even Lucasfilm - all of whom loaned materials to Plumb for the display.

It was through these personal relationships that Plumb acquired many of the finest pieces in his collection. Throughout the years, Plumb organized or appeared at countless other events and shows, where he proudly displayed his collection and discussed his passion for Star Wars original art with both artists and fans. In 1996, Plumb hosted a panel at San Diego Comic Con on collecting Star Wars artwork specifically. In 2001, he and a small group of fellow collectors commissioned Lawrence Noble to produce the now-famous "Bronze Yoda." Plumb's bronze Yoda statue was perennially displayed at The California State Fair for fans to see and enjoy.

Propstore is pleased and honored to offer these fantastic lots from Plumb's collection, including Noble's matching number Artist Proofs of the bronze Yoda and Darth Vader statues, sketches and paintings from McQuarrie, Struzan, Noble, Dorman, Kazu Sano, Tim Hildebrandt, John Gampert, Ken Barr, Vincent Di Fate, and many more.

Please see lots on Day 3 for additional materials from the William Plumb Collection.

**435**  
William Plumb Collection: Hand-Drawn  
Tim Reamer Style "A" One-Sheet Concept Sketch  
**Star Wars: Episode VI - Return Of The Jedi (1983)**

A concept sketch hand-drawn by posterist Tim Reamer for a style "A" one-sheet for Richard Marquand's Star Wars: Return of the Jedi. One-sheets featuring Reamer and Paykos Phior's final artwork of a blue lightsaber raised with two hands, modeled after George Lucas' hands, were the first posters promoting the film's international theatrical release. This earlier sketch featured one hand on the lightsaber and additional characters that were later excised from the composition.

This concept sketch for the one-sheet comes from the personal collection of William Plumb. It is rendered in mixed media on graphite-bordered paper. A printed black-and-white copy of an alternate, unpublished comp poster design featuring two hands on a lightsaber is included, though the final poster itself is not included. The sketch exhibits tearing on its bottom right corner and edges. Dimensions: 14" x 17" (35.5 cm x 43.25 cm)

Sold without copyright; see notice in the Buyer's Guide.

**Estimate: \$4,000 - 8,000**



Two-handed lightsaber concept (photocopy)



One-handed lightsaber concept (graphite on tissue)

24" (61 cm)

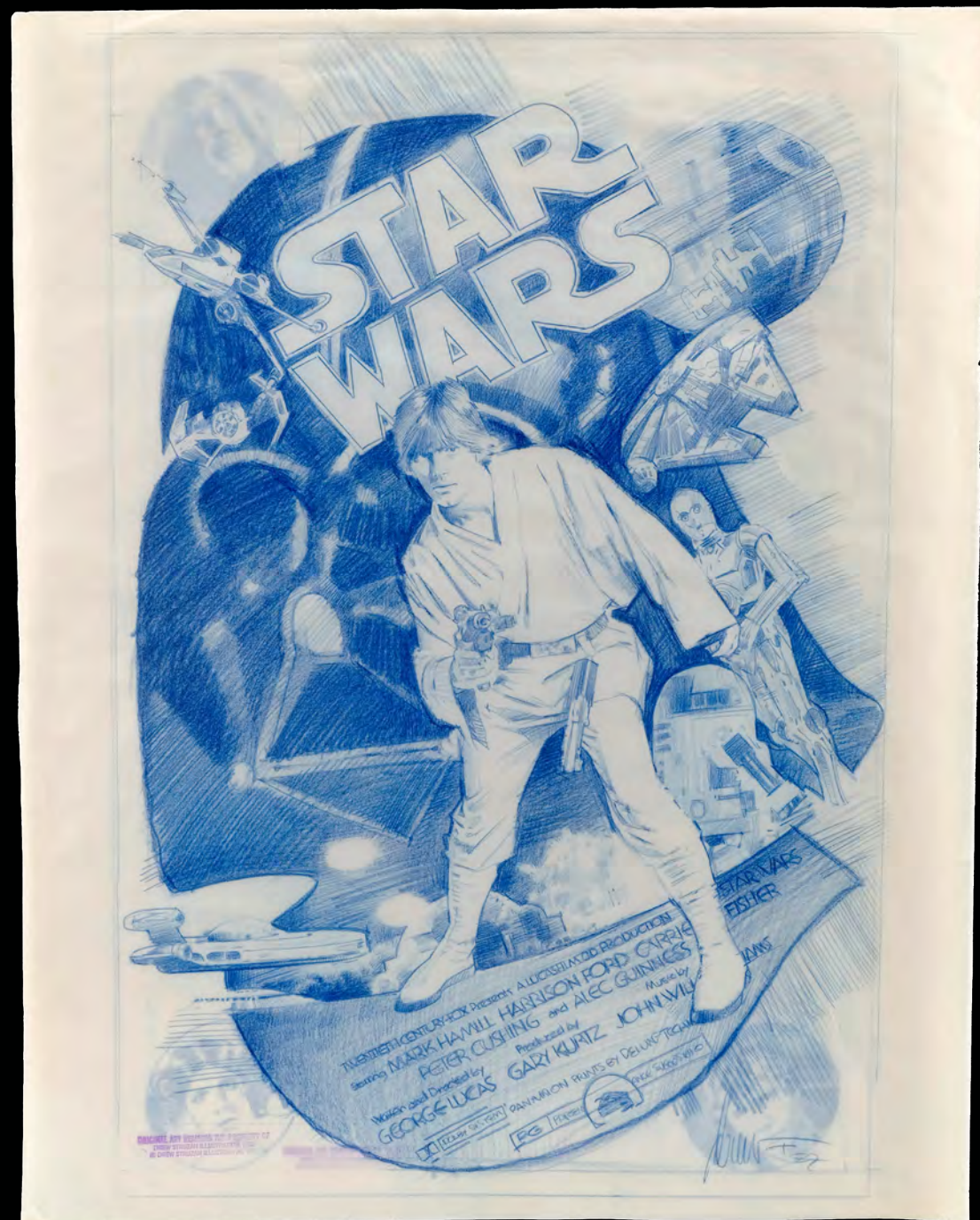

Primary Illustration with Secondary Illustration Set Behind

**436**  
 William Plumb Collection: Matched Pair of Hand-Drawn Drew Struzan 10th Anniversary Comprehensive Sketches  
**Star Wars: Episode IV - A New Hope (1977)**

Hand-drawn Drew Struzan 10th anniversary comprehensive sketches from George Lucas' Star Wars: A New Hope. Struzan created these sketches for movie posters in celebration of the film's 10th anniversary. This lot comes from the personal collection of William Plumb. It consists of one final draft "Star Wars" poster featuring Luke Skywalker and Darth Vader in the background and one border concept sketch featuring Princess Leia, Han Solo, and Obi-Wan Kenobi, both of which are rendered in blue color pencil on tracing paper with official Drew Struzan Illustration, Inc. stamps along their bottoms. These 1980-era Struzan originals are extremely scarce and highly sought after by collectors. They exhibit pinholes and minor discoloration from age. Dimensions: (largest) 19" x 24" (48.5 cm x 61 cm)

Sold without copyright; see notice in the Buyer's Guide.

**Estimate: \$15,000 - 30,000**



Secondary Illustration with Additional Details (not to scale)

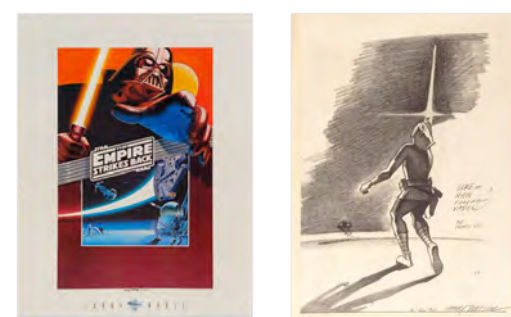

**437**  
 William Plumb Collection: Hand-Drawn Lawrence Noble 10th Anniversary Poster Black-and-White Comps with Color Print  
**Star Wars: Episode V - The Empire Strikes Back (1980)**

Two hand-drawn black-and-white comps with a color print of a poster by artist Lawrence Noble for Irvin Kershner's Star Wars: The Empire Strikes Back. Noble created poster designs for the theatrical release circa 1980, but his illustration of Darth Vader's gloved hand was ultimately only used to promote the 10th anniversary re-release.

This lot comes from the personal collection of William Plumb. It consists of two black-and-white comps rendered in graphite on paper and dated "2-12-80" and "2-14-80," as well as a credits-free print of the final poster labeled "Larry Noble Illustrator" and dated "8-9-80." The set exhibits edge wear with staining on the comps' backs. Dimensions: (largest) 26" x 21" (66 cm x 53.5 cm)

Sold without copyright; see notice in the Buyer's Guide.

**Estimate: \$8,000 - 16,000**



53" (134.75 cm)

**438**  
 William Plumb Collection: Framed Hand-Drawn Mix or Match Storybook Cover and Interior Artwork  
**Star Wars: Episode V - The Empire Strikes Back (1980)**

Framed cover and interior artwork hand-drawn by illustrator Wayne Douglas Barlowe for the Mix or Match Storybook published by Random House and Lucasfilm in 1980 as a tie-in Irvin Kershner's Star Wars: The Empire Strikes Back.

This lot comes from the personal collection of William Plumb. It consists of nine framed and matted mixed media book illustrations, including the cover featuring Darth Vader, Luke Skywalker, and Yoda; a cover page sketched in graphite on tracing paper; a printed cover page with handwritten annotations rendered on tracing paper; and a 1984 letter from Random House confirming the return of the artwork to Barlowe. This lot exhibits discoloration on the tracing paper. Dimensions: 40" x 53" x 4" (101.75 cm x 134.75 cm x 10.25 cm)

Sold without copyright; see notice in the Buyer's Guide.

**Estimate: \$6,000 - 12,000**





**439**  
 William Plumb Collection: Hand-Drawn  
 Drew Struzan "America's Movies for the  
 World's Athletes" Comprehensive Artwork  
**1984 Summer Olympics**

Comprehensive artwork hand-drawn by Drew Struzan for competing athlete poster gifts at the 1984 XXIII Olympic Games in Los Angeles. Produced by Struzan, Jane Firszenberg, and Steven Spielberg, the "America's Movies for the World's Athletes" posters depicted iconic characters from cinema, including Charles Foster Kane, E.T., and Darth Vader. The final versions slightly differed from this poster study piece, and were marked "final" during printing.

This artwork comes from the personal collection of William Plumb. It is rendered in brown, black, and white charcoal on tan paper and stamped with Struzan's copyright. The artwork exhibits adhesive residue and minor edge wear. Dimensions: 28" x 34" (71.25 cm x 86.5 cm)

Sold without copyright; see notice in the Buyer's Guide.

**Estimate: \$6,000 - 12,000**



**440**  
 William Plumb Collection: Hand-Painted  
 Kazuhiko Sano Poster Concept Illustration  
**Caravan Of Courage: An Ewok Adventure (1984)**

Poster concept illustration hand-painted by Kazuhiko Sano for John Korty's sci-fi fantasy TV movie Caravan of Courage: An Ewok Adventure. Elements from this illustration are visible in the final version of the one-sheet distributed internationally to promote the movie. Sano's lent his artwork to Return of the Jedi's Style B poster.

This lot comes from the personal collection of William Plumb. Painted on posterboard, this painting features Mace Towani (Eric Walker), Cindel Towani (Aubree Miller), Wicket the Ewok (Warwick Davis) amongst the Ewok caravan. It features Kazu Sano's monogrammed signature in orange on the right side. This lot exhibits light scratches on the back, a black strip of tape across the top, and adhesive marks on the back of the board. Dimensions: 28" x 35" x 3" (71.25 cm x 89 cm x 7.75 cm)

Sold without copyright; see notice in the Buyer's Guide.

**Estimate: \$5,000 - 10,000**



**441**  
 William Plumb Collection:  
 Framed Hand-Drawn Drew Struzan Style "B" One-Sheet Color Comp  
**Caravan Of Courage: An Ewok Adventure (1984)**

A framed color comp hand-drawn by poster artist Drew Struzan for an international style "B" one-sheet for John Korty's sci-fi TV movie Caravan of Courage: An Ewok Adventure. The comp depicts Wicket W. Warrick (Warwick Davis), Mace Towani (Eric Walker), and Cindel Towani (Aubree Miller) with the Ewok Caravan against a forested Endor backdrop.

This comp comes from the personal collection of William Plumb. It is rendered in mixed media, titled "The Ewok Caravan," and signed by Struzan on board. This prelim art was featured on Topps' Star Wars Galaxy Series 3 card #297. The comp comes mounted behind glass in a brown wooden frame. The frame exhibits minor scuffs. Dimensions: 29" x 36" x 3" (73.75 cm x 91.5 cm x 7.75 cm)

Sold without copyright; see notice in the Buyer's Guide.

**Estimate: \$8,000 - 16,000**





**442**  
William Plumb Collection: Framed Hand-Drawn Drew Struzan Style "B" One-Sheet Black-and-White Comp  
**Caravan Of Courage: An Ewok Adventure (1984)**

A framed black-and-white comp hand-drawn by poster artist Drew Struzan for a one-sheet for John Korty's sci-fi TV movie Caravan of Courage: An Ewok Adventure. The comp depicts Wicket W. Warrick (Warwick Davis), Mace Tawani (Eric Walker), and Cindel Towani (Aubree Miller) with the Ewok Caravan against a forested Endor backdrop.

This comp comes from the personal collection of William Plumb. It is rendered and signed in graphite on paper and stamped with a "Drew Struzan Illustration" trademark. This prelim art was featured on the back of Topps' Star Wars Galaxy Series 3 card #297. The comp comes mounted behind glass in a brown wooden frame. The frame exhibits minor scuffs. Dimensions: 29" x 34" x 2" (73.75 cm x 86.5 cm x 5 cm)

Sold without copyright; see notice in the Buyer's Guide.

**Estimate: \$5,000 - 10,000**

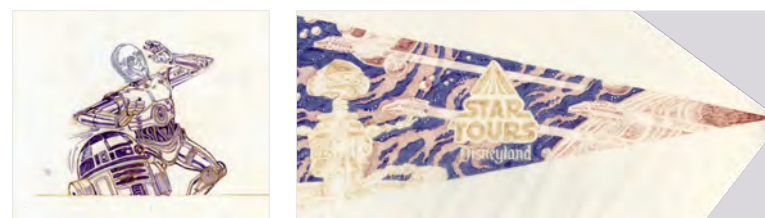

**443**  
William Plumb Collection: Set of Hand-Drawn Concept Artworks with Promotional Material  
**Star Wars: Star Tours (1987)**

Concept artworks hand-drawn by artist Stephen Sandoval with promotional materials for Disney's Star Wars: Star Tours. In the theme park attraction, visitors traveled through the galaxy in a motion simulator guided by RX-24 (Paul Reubens).

This lot comes from the personal collection of William Plumb. It consists of three Star Tours logo artworks rendered in mixed media on tracing paper; a mixed media artwork depicting C-3PO and R2-D2; a vinyl Star Tours bumper sticker; a color-printed photograph of the artwork; and a Letter of Authenticity from Sandoval. The artworks exhibit edge wear and visible crease lines throughout. Dimensions: 18" x 13.5" (45.75 cm x 34.5 cm)

Sold without copyright; see notice in the Buyer's Guide.

**Estimate: \$2,500 - 5,000**



**444**  
William Plumb Collection:  
Framed Hand-Painted Ralph McQuarrie Cover Artwork  
**Robot Visions (1990)**

Artwork hand-painted by famed sci-fi illustrator Ralph McQuarrie for the cover of Robot Visions, a collection of Isaac Asimov's short stories. Best known for his concept artwork for George Lucas' original Star Wars trilogy, McQuarrie also contributed art to various publications in Asimov's groundbreaking Robot series.

This artwork depicting a laser-eyed robot amidst a technological city comes from the personal collection of William Plumb. It is rendered in mixed media on paper, signed in the bottom right corner by McQuarrie, and mounted behind glass in a black and brown wooden frame. The frame's paper backing exhibits punctures and scratches from hanging. Dimensions: 24" x 30" x 3" (61 cm x 76.25 cm x 7.75 cm)

Sold without copyright; see notice in the Buyer's Guide.

**Estimate: \$15,000 - 30,000**



27" (68.5 cm)

**445**  
 William Plumb Collection: Hand-Painted Ralph McQuarrie Cover  
 Illustration  
**Isaac Asimov's Inferno**

A cover illustration hand-painted by Ralph McQuarrie for Roger MacBride Allen's book Isaac Asimov's Inferno. McQuarrie provided the cover art for this sequel that explored and examined Asimov's Three Laws of Robotics.

This illustration of a robot with arms outstretched before a sun and distant cityscapes comes from the personal collection of William Plumb. It is rendered in mixed media on Crescent Illustration Board with a Byron Preiss Visual Publications sticker on the reverse. The board exhibits adhesive residue and some edge wear. Dimensions: 27" x 20" x 3" (68.5 cm x 51 cm x 7.75 cm)

Sold without copyright; see notice in the Buyer's Guide.

**Estimate: \$6,000 - 12,000**

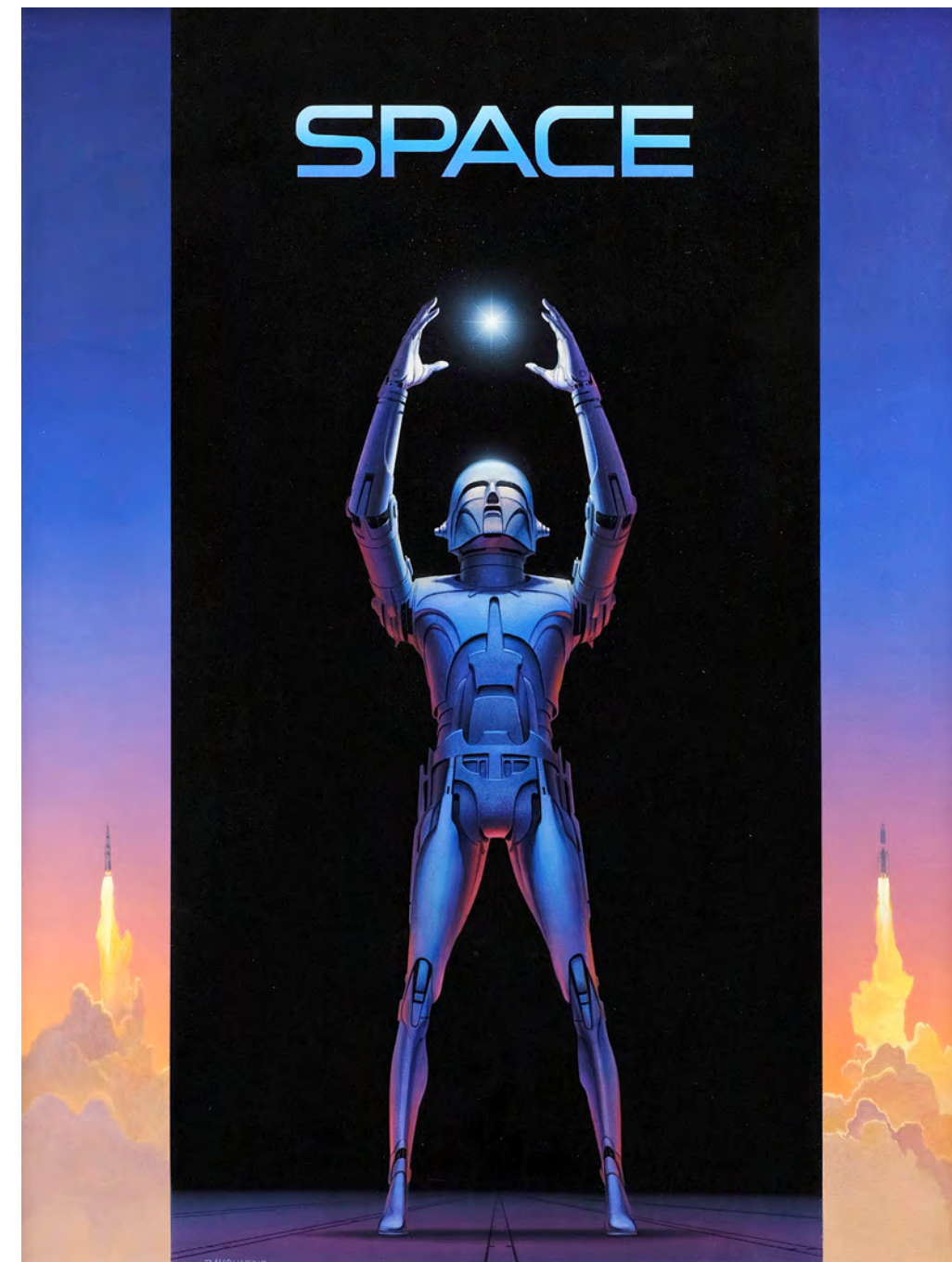
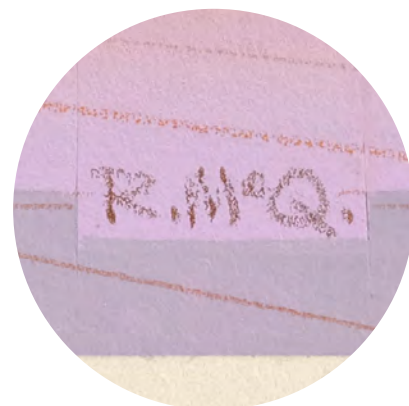

41" (104.25 cm)



**446**  
 William Plumb Collection:  
 Hand-Painted Ralph McQuarrie "Space: Fantasy and Reality" Poster Artwork  
**Star Wars: Various Productions**

Poster artwork hand-painted by illustrator Ralph McQuarrie to promote the Space: Fantasy & Reality art expo held at the Maturango Museum in October 1986. Collector William Plumb brought revered Star Wars artists McQuarrie, Drew Struzan, and Lawrence Noble to the one-time-only expo as a fundraiser benefiting the handicapped.

This lot comes from the personal collection of Plumb. The artwork resembles the style of robots McQuarrie created for Star Wars and was created larger in scale than his normal formatting. It features a blue and purple highlight mixed media hand-painted robot with its arms above its head with a light source and "SPACE" in a painted blue gradient. This piece comes triple-matted in blue, black, and purple matting in a black wood and fiberglass frame. A May 9, 1986 hand-written letter from McQuarrie to Plumb concerning the poster design, accompanied by a small color thumbnail and various photocopy pages of design concepts, are included. The lot exhibits minor chipping to the frame. Dimensions: 41" x 33" x 3" (104.25 cm x 84 cm x 7.75 cm)

Sold without copyright; see notice in the Buyer's Guide.

**Estimate: \$10,000 - 20,000**





**447**  
 William Plumb Collection: Hand-Painted Dave Dorman  
 Star Wars: Dark Empire No. 6 Cover Artwork and Prelim  
 Dark Horse Comics

Cover artwork hand-painted by Star Wars artist Dave Dorman and a prelim for Star Wars: Dark Empire no. 6 published by Dark Horse Comics in October 1992. The artwork depicts Luke Skywalker and Emperor Palpatine dueling in front of a lightsaber-wielding Leia Organa.

This lot comes from the personal collection of William Plumb. The color artwork is rendered in mixed media and signed by Dorman, while the prelim for the artwork is rendered and annotated throughout the margins in pen on Dorman's letterhead. Included are letters from Dorman to Plumb, which include a backstory on the Dark Empire #6 cover. The prelim exhibits some bending from age. Dimensions: 22" x 29" x 3" (56 cm x 73.75 cm x 7.75 cm)

Sold without copyright; see notice in the Buyer's Guide.

**Estimate: \$10,000 - 20,000**

29" (73.75 cm)



Dark Horse Comics Comic Book  
 Star Wars: Dark Empire #6 (1992)

**448**  
 William Plumb Collection:  
 Hand-Painted "Yoda's World"  
 Trading Card Painting  
 Star Wars Toys

A "Yoda's World" trading card painting hand-painted by artist John Rheume for Topps' Star Wars Galaxy Series trading cards. Rheume created this painting to explore Yoda's backstory, but as it did not receive Lucasfilm's approval, the card was ultimately pulled and destroyed by Topps. Some of these cards survived the pulped run, and the piece was later authorized for the Series 4 trading card series circa 2009.

This mixed media painting depicting Yoda with others of his species comes from the personal collection of William Plumb. It is signed by Rheume in silver-color marker. Also included are a plastic-sheathed surviving Series 2 Mint-graded "Yoda's World" trading card; a Letter of Authenticity from Rheume; and five photographs, including one featuring Rheume holding this painting. The painting exhibits minor edge wear. Dimensions: 32" x 26" x 3" (81.25 cm x 66 cm x 7.75 cm)

Sold without copyright; see notice in the Buyer's Guide.

**Estimate: \$5,000 - 10,000**



Topps Star Wars Galaxy: Series 2  
 Rare Promo Trading Card (1993)

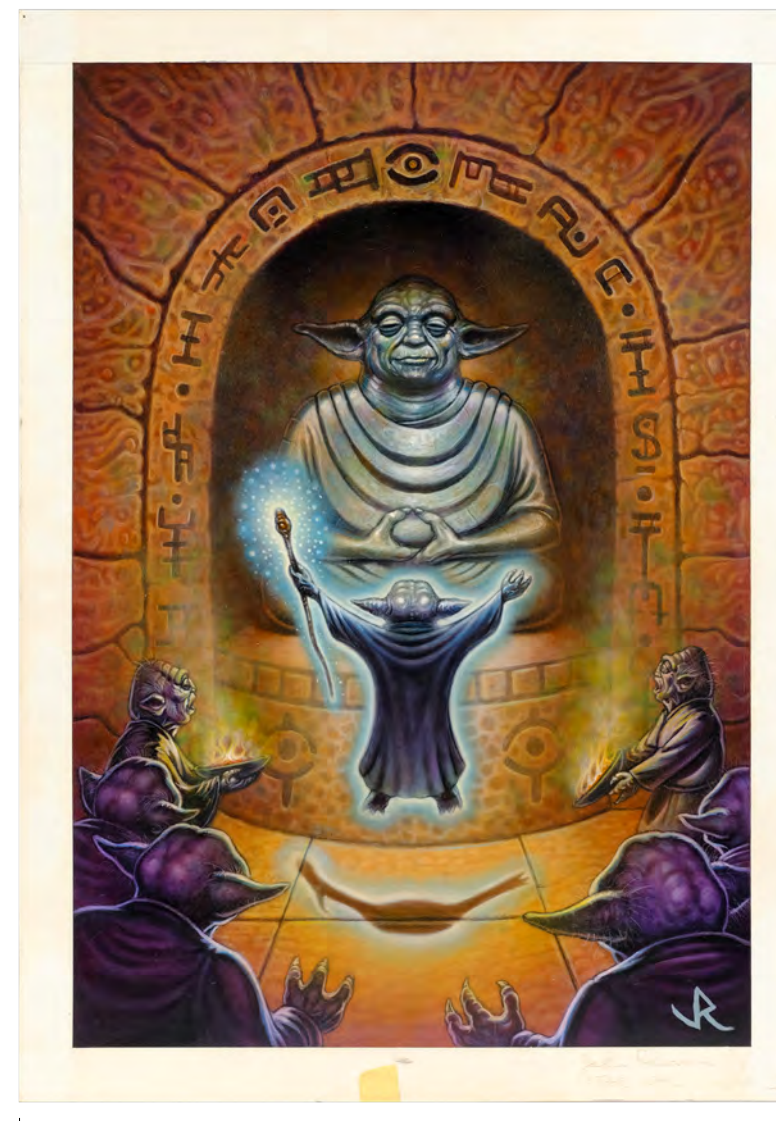

26" (66 cm)

**449**  
 Hand-Drawn Ralph McQuarrie  
 "The Imperial Stormtrooper"  
 Concept Sketch  
 Star Wars: The Mos Eisley Cantina  
 Pop-Up Book (1995)

A concept sketch of "The Imperial Stormtrooper" hand-drawn by Ralph McQuarrie for Kevin J. Anderson and Rebecca Moesta's children's book The Mos Eisley Cantina Pop-Up Book. As the project's primary illustrator, renowned Star Wars franchise artist McQuarrie created multiple concept artworks featuring imperial stormtroopers, ultimately incorporating one into his "The Moisture Farmer" illustration.

This concept sketch featuring three angles of a stormtrooper on Tatooine in varying detail is rendered in graphite and red pencil on bordered vellum taped to backing board. This sketch is also featured on page 353 of the Abrams publication Star Wars Art: Ralph McQuarrie. Both the tape and vellum exhibit yellowing from age. Dimensions: 18.25" x 12" (46.5 cm x 30.5 cm)

Sold without copyright; see notice in the Buyer's Guide.

**Estimate: \$3,000 - 6,000**

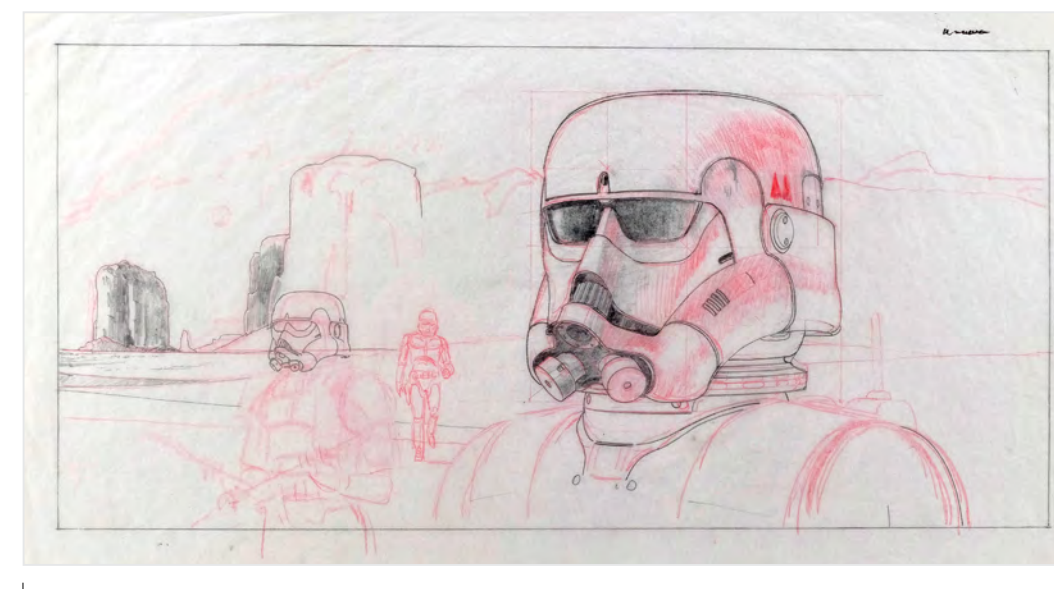

18.25" (46.5 cm)



**450**  
 William Plumb Collection:  
 Limited-Edition Lawrence Noble  
 Bronze Yoda Statue Artist Proof  
**Star Wars: Original Trilogy**  
**(1977-1983)**

A limited-edition artist proof of a bronze Yoda statue designed by Star Wars artist Lawrence Noble. Noble's bronze Yoda statue is well known to Star Wars fans due to the example installed in a fountain at Lucasfilm's Presidio offices. The now-famous statue had a long development route: after seeing Irvin Kershner's *Star Wars: The Empire Strikes Back* in 1981, Noble sculpted an 8-inch clay model of Yoda. Four years later, collector William Plumb commissioned a bronze casting from Noble's small Yoda sculpture. That led to Killian Enterprises producing a licensed 8-inch version from the same Noble sculpt in 1990, to celebrate *Empire's* 10th anniversary. The success of the 10th anniversary small-scale Yoda contributed to Noble developing a full-size bronze Yoda statue in the early 2000s.

Noble first produced six artist proofs of the bronze Yoda statues; five went to private collectors and the sixth was gifted to George Lucas. Subsequently, a run of 30 statues was made available to the public. George Lucas purchased several more of the bronze Yodas and installed one at Lucasfilm's Presidio Campus Fountain circa 2005; today it is a mecca for Star Wars fans from around the globe.

This lot, Artist Proof # 3 of 6, comes from Plumb's personal collection. It features a Noble Studio plaque on the base engraved with Noble's signature and the AP number. Also included are a July 12, 1985 letter from Noble to Plumb regarding the first small-scale bronze Yoda; a progress binder with 107 color photos of Noble sculpting the statue; an original purchase invoice from Noble Studio dated October 2001; and a color photo of the completed full-size statue on the Lucasfilm fountain signed by Noble. The statue exhibits aging to its patina from exposure and age. Dimensions: 24" x 24" x 34" (61 cm x 61 cm x 86.5 cm). Special shipping required; see notice in the Buyer's Guide.

**Estimate: \$25,000 - 50,000**



Lucasfilm Yoda Fountain Postcard Signed by Lawrence Noble (2007)



34" (86.5 cm)



Signature Plaque Detail





**451**  
William Plumb Collection:  
Limited-Edition Half-Scale  
Lawrence Noble Bronze Darth Vader Statue  
**Star Wars: Original Trilogy (1977-1983)**

A limited-edition bronze statue of Darth Vader from George Lucas' Star Wars saga designed by Star Wars artist Lawrence Noble. This half-scale statue was created circa 2006 as a follow up to Noble's full-scale bronze Yoda (see previous Lot 450). It was limited to six artist proofs and 30 retail units originally priced at \$18,000.

This statue comes from the personal collection of William Plumb. It features a Noble Studio plaque on the base engraved with Noble's signature and numbered "3/6 AP." The statue depicts Darth Vader in his iconic pose from The Empire Strikes Back, with his hands on his belt and his lightsaber on his side. It is designed with a circular base that allows the statue to be displayed from any angle. The base exhibits minor scuffing on its underside and some discoloration where it may have once been wet; it also exhibits aging to its patina from exposure and time. Dimensions: 20" x 20" x 46" (51 cm x 51cm x 117 cm)

Special shipping required; see notice in the Buyer's Guide.

**Estimate: \$20,000 - 40,000**

46" (117 cm)



Signature Plaque Detail





Interior Metal Plate Detail

**452**  
 William Plumb Collection:  
 Lawrence Noble-Designed 10.5-inch  
 Bronze Darth Vader Statue  
**Star Wars: Original Trilogy (1977-1983)**

A bronze statue of Darth Vader from George Lucas' Star Wars saga designed by Star Wars artist Lawrence Noble. This 10.5" statue was based on the half-size bronze statue Noble created for the Skywalker Ranch. The half-size statue was limited to six artist proofs and 30 retail units originally priced at \$18,000.

This statue comes from the personal collection of William Plumb. It features Darth Vader in his iconic pose from The Empire Strikes Back, with his hands on his belt and his lightsaber on his side. The statue is mounted to a high-gloss black-painted resin circular base that allows the statue to be displayed from any angle. The base exhibits minor scuffing on its underside and some discoloration where it may have once been wet. Dimensions: 5" x 5" x 10.5" (12.75 cm x 12.75 cm x 26.75 cm)

**Estimate: \$1,000 - 2,000**

**453**  
 The Estate of Jeremy Bulloch's  
 Replica Boba Fett Helmet  
**Star Wars: Episode V - The Empire Strikes Back (1980)**

A replica Boba Fett helmet from the estate of Fett actor Jeremy Bulloch. Boba Fett made his debut in Irvin Kershner's Star Wars: The Empire Strikes Back as the bounty hunter responsible for capturing Han Solo (Harrison Ford).

This 1:1 scale Deluxe replica Boba Fett helmet was designed, inscribed on the base, and personally presented by Don Post to Bulloch, who wore it in interviews and promotional photographs over the years. It is constructed from black velvet-padded fiberglass hand-painted army green, maroon, and silver-color with a black acrylic visor, an articulating rangefinder, and a custom-made wooden base painted army green with Mandalorian-style etchings. The helmet's interior is affixed with a metal plate engraved "Jeremy Bulloch," and the base is signed by Post with an inscription to Bulloch. Also included is a Certificate of Authenticity from Jeremy Bulloch's estate. This lot exhibits intentional distressing on the helmet and minor grime to the base.

**Estimate: \$6,000 - 12,000**



**454**  
 LEGO George Lucas Minifigure  
**Star Wars Toys**

A LEGO minifigure of George Lucas, founder of Lucasfilm and creator of Star Wars. Specially made exclusively for the LEGO design team in Billund, Denmark, the George Lucas minifigure was never released to the public and is exceedingly rare.

This plastic minifigure features gray hair and painted details including a gray beard, a blue button-up shirt with brown grid lines, and gray legs. The figure exhibits minimal wear to the painted finish. Dimensions: 1.75" x 0.75" x 0.5" (4.5 cm x 2 cm x 1.5 cm)

**Estimate: \$8,000 - 16,000**

**455**  
 LEGO "Han Shot First"  
 Greedo Minifigure  
**Star Wars Toys**

A LEGO minifigure of Greedo from George Lucas's Star Wars: A New Hope wearing a "Han Shot First" shirt. Specially made exclusively for the LEGO design team in Billund, Denmark, the "Han Shot First" Greedo minifigure was never released to the public.

This plastic minifigure features a uniquely sculpted Greedo head painted teal, a black torso with white font reading "Han Shot First," yellow and blue arms with black stripes, and pale yellow legs. The figure exhibits minimal wear to the painted finish. Dimensions: 1.75" x 0.75" x 0.5" (4.5 cm x 2 cm x 1.5 cm)

**Estimate: \$2,000 - 4,000**



72" (183 cm)

Staff Detail

**456**  
 Rey's (Daisy Ridley)  
 Promotional Prop Staff  
**Star Wars: Episode VII  
 - The Force Awakens (2015)**

A promotional prop of Rey's (Daisy Ridley) staff from J.J. Abrams' Star Wars: The Force Awakens. Propshop, the industry prop and set decoration fabricator that created many props for The Force Awakens, released limited-edition prop replicas in partnership with Disney and Lucasfilm. The pieces were made from original 3-D scan data from the production to ensure utmost accuracy.

Used in marketing events, the 3-D-printed staff is painted gray to resemble aged metal and features linen and leather wraps that have been distressed to simulate age and a brown woven cotton strap. The staff exhibits some scuffing to its finish. Dimensions: 72" x 3" x 3" (183 cm x 7.75 cm x 7.75 cm)

Special shipping required; see notice in the Buyer's Guide.

**Estimate: \$4,000 - 8,000**



34" (86.5 cm)



**457**  
**BB-8 Promotional Display**  
**Star Wars: Episode VII - The Force Awakens (2015)**

A promotional display of BB-8 from J. J. Abrams' Star Wars: The Force Awakens. The astromech droid of pilot Poe Dameron (Oscar Isaac), BB-8 befriended the scavenger Rey (Daisy Ridley) on the desert planet Jakku.

This static replica droid is rendered in mixed media, including fiberglass, plastic, and resin, and features a white and orange paint scheme with gray embellishments and applied distressing, two rubber antennas, and blue plastic lenses for its hologram projector and radar eye. The lot was built for marketing and promotional events and is an accurate replica of the actual prop. It is displayed on a dark gray base. The droid and base exhibit minimal scuffing. Dimensions: 20" x 20" x 34" (51 cm x 51 cm x 86.5 cm)

**Estimate: \$30,000 - 60,000**





**458**  
Lamia's (Michelle Pfeiffer)  
Screen-Matched Innkeeper Costume Δ  
**Stardust (2007)**

Lamia's (Michelle Pfeiffer) screen-matched innkeeper costume from Matthew Vaughn's fantasy adventure Stardust. The evil witch Lamia wore her costume while posing as an innkeeper's wife to trick Yvaine (Claire Danes) and cut out her heart.

The costume consists of a built-in bodice with maroon textured cotton sleeves with a ribbon-laced front; a full-length matching maroon skirt layered with an attached black underskirt featuring a ruffled hem; and a cream-colored linen apron with "SM" printed on an upper corner. Multiple gathered fabric circles decorate the bodice and can be matched to several scenes where Lamia appears as the innkeeper's wife. Attached within the skirt is a padded bum roll which adds fullness to the back. This costume exhibits discoloration on the apron and minor wear to some of the stitching, while a small section of fraying is present on the back neckline of the bodice.

**Estimate: \$6,000 - 12,000**



**459**  
Dave Jones Collection:  
Rodger Young Background Model Miniature  
**Starship Troopers (1997)**

A Rodger Young background model miniature from Paul Verhoeven's sci-fi satire Starship Troopers. Constructed by Thunderstone model shop for background use, this model also served as reference for the Klendathu-sent asteroid collision scene.

This green-gray-painted renshape and resin miniature comes from the collection of veteran model maker Dave Jones. It features two circle-and-plus sign black hand-marks along the upper after spine and a threaded nut at the bottom amidships for rig mounting. It exhibits damage, cracking, missing pieces, loose parts, scratching, scuffing, and grime from wear and conveyance. Dimensions: 19" x 6" x 3" (48.25 cm x 15.25 cm x 7.75 cm)

**Estimate: \$2,000 - 4,000**

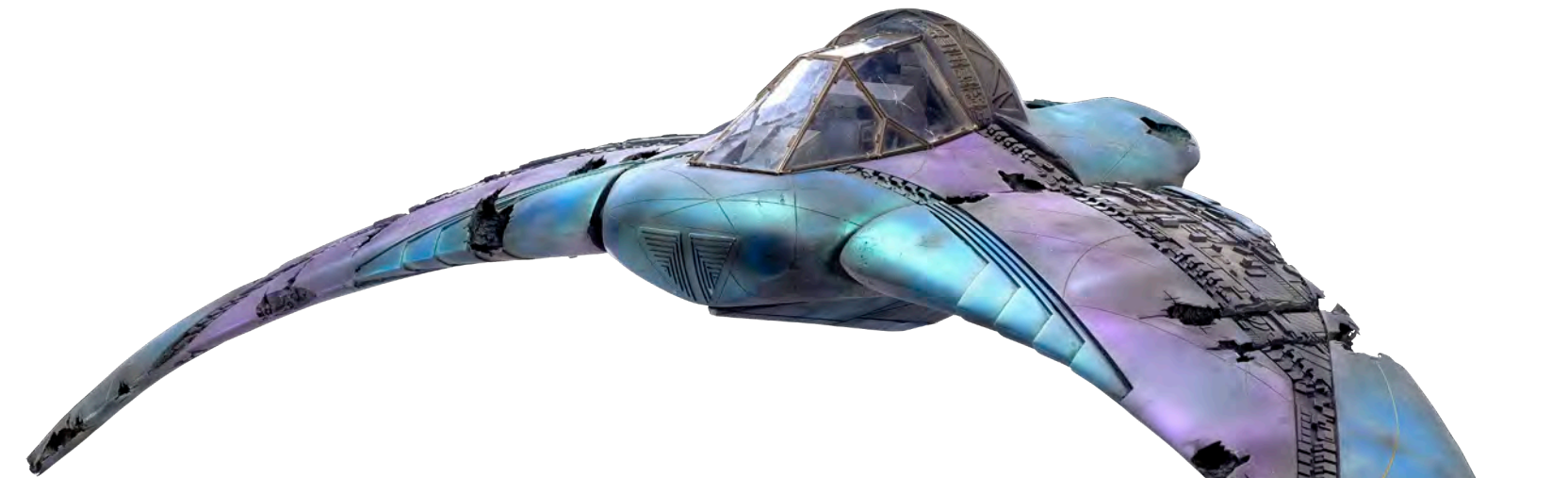

**460**  
Screen-Matched Battle-Damaged  
Death Glider Model Miniature  
**Stargate SG-1 (1997-2007)**

A screen-matched, battle-damaged Death Glider model miniature from the sci-fi television show Stargate SG-1. Death Gliders were Goa'uld space superiority fighters, deployed against multiple space targets. This model was screen-matched to Season 2's "The Serpent's Lair," where SG-1 and Bra'tac escaped Apophis' Ha'tak mothership in two Gliders damaged during that ship's subsequent destruction.

The miniature's body is lightweight rigid foam covered in a rigid skin, painted metallic blue, silver-color, and purple with gold-color paint inlaid in etching, and is assembled in three parts, forming the fuselage and heavily curved wings. The resin and clear acrylic canopy features spider-crack damage, showing the dual-seat cockpit and decal control surfaces. Paint markings suggest the cockpit replaced an earlier canopy. Two resin staff cannons are slung underwing. The surface is painted metallic blue and purple, and etched with curved, gold-color painted lines. There are battle damage marks representing laser blasts, and gray paint depicts smoke and burn damage. It exhibits small chips to the paint and hot glue residue at assembly points. Dimensions: 41" x 21" x 11" (105 cm x 53.5 cm x 28 cm)

Special shipping required; see notice in the Buyer's Guide.

**Estimate: \$8,000 - 16,000**



41" (105 cm)



Bottom View





RGR Collection / Alamy Stock Photo

**461**  
Steve McQueen's  
Production Company 1971  
Husqvarna 400 Cross Motorcycle  
Solar Productions

A 1971 Husqvarna 400 Cross motorcycle owned by Steve McQueen's production company, Solar Productions. McQueen, an avid bike enthusiast, owned at least two other Husqvarna Moto-Cross bikes, one of which he rode in the Camp Pendleton sequence of Bruce Brown's 1971 motorcycle documentary On Any Sunday. A second McQueen-owned Moto-Cross appeared on the cover of Sports Illustrated in August 1971.

McQueen had a Husqvarna Enduro that he exchanged with Husqvarna Motorcorp West for this specific Moto-Cross numbered MI-4666 circa 1971, as verified by documents between Solar Productions and Husqvarna Motorcorp West circa 1972. The screen captures on this listing depict another example of this same model of bike also owned by McQueen.

This modified bike includes a modified, cut frame, repositioned Koni shocks, a custom swing arm, custom foot pegs, Ceriani forks welded to a custom front backing plate, H.D. fork stops, and a customized front backing plate. It is drained of fluid, rendering it nonfunctional, and no warranty is made regarding its roadworthiness. It exhibits damage to the red finish on its tank, cracked plastic beneath the seat, and grime in the tires from use.

The motorcycle is intended for display purposes only. It is not designed for street use. Due to its copyright status, the public display of the bike must be approved by permission of the copyright holder through a direct arrangement with Propstore upon purchase. A deed of gift will be included. Transportation and shipping quotes should be arranged with Propstore before bidding. Dimensions: 62" x 37" x 45" (157.5 cm x 94 cm x 114.5 cm)

Contains electronics and mechanical components; see notices in the Buyer's Guide.

Special shipping is required; see the notice in the Buyer's Guide.

**Estimate: \$50,000 - 100,000**





102" (259.25 cm)

**462**  
Full-Size Mechanized Soldier, War Dog, and Bloodied Orc Shop Display  
**Sucker Punch (2011)**

A full-size mechanized soldier, war dog, and bloodied orc shop display based on Zack Snyder's action-fantasy film Sucker Punch. Baby Doll (Emily Browning) and her elite team fought against mechanically-revived German soldiers and an orc army.

Created by Quantum Creation FX for display in their workshop, this lot consists of a mechanized soldier with its war dog companion and an orc. The soldier features a gray helmet with wires, a metallic gas mask, a black leather trench coat, a black leather belt and harness with pouches and a gold-color buckle, a gray wool collared undercoat, black leather gloves and boots, a Stielhandgranate with a radiation trefoil logo tucked into the belt, and a Mauser in the right hand. In the left hand is a chain attached to the brown leather harness of a dog-like creature with dark red foam latex skin, yellow resin teeth, pale eyes, and a harness. The orc features green foam latex skin; acrylic eyes, resin teeth and tusks; a metal nose ring; long gray hair with leather and fabric tied into it; full body armor made of leather, faux fur, metal, and resin over a red woven cotton undersuit; cotton leg wraps and twine ties; crude weaponry; and a large bloody ax. The figures are displayed on a wood and fiberglass base simulating a destroyed tank partially buried under sand with a Quantum Creations logo in the sand. The soldier's mask is an original production-used animatronic mask. The rest of the lot was created specifically for the display, with the war dog cast from an original production mold that Quantum Creations made for the film. A power cord runs out from behind the soldier but electronic elements are currently non-functioning. The foam latex exhibits wear, including cracking, and the base exhibits finish scuffing. Dimensions: 148" x 96" x 102" (376 cm x 244 cm x 259.25 cm)

Contains electronics and mechanical components; see notices in the Buyer's Guide.

Ownership may be restricted in some countries; see replica firearm notice in Buyer's Guide.

Stored off-site; see off-site storage notice in the Buyer's Guide.

Special shipping required; see notice in the Buyer's Guide.

**Estimate: \$20,000 - 40,000**



**463**  
Deadshot's (Will Smith)  
Stunt ZEV Pistol and Magazines  
**Suicide Squad (2016)**

Deadshot's (Will Smith) stunt ZEV pistol and magazines from David Ayer's superhero film Suicide Squad. Deadshot wielded his signature pistol when he faced off against the Enchantress (Cara Delevingne) and Incubus (Alain Chanoine).

This lot consists of a custom-designed black foam and rubber stunt pistol modeled from a ZEV handgun. Painted maroon and gold-color with a sparkly textured grip, this pistol comes with foam rubber magazines with gold-color painted tops and a plastic clip. Each component is intentionally distressed by production to appear well-used. This lot exhibits cracking, a broken clip, and notable paint marks. Dimensions: 10.75" x 7.5" x 1.75" (26.75 cm x 18.5 cm x 4 cm)

Ownership may be restricted in some countries; see replica firearm notice in Buyer's Guide.

**Estimate: \$2,500 - 5,000**



**464**  
Fortress of Solitude Crystal  
**Superman (1978)**

A Fortress of Solitude crystal from Richard Donner's superhero film Superman. Crystals rose to meet Superman (Christopher Reeve) when he summoned the consciousness of his father Jor-El (Marlon Brando) in his otherworldly Arctic retreat.

This lot consists of a clear resin cylindrical crystal shard with an angled end. The shard exhibits adhesive and gold-color residue from production use. Dimensions: 12" x .5" x .5" (30.48 cm x 1.27 cm x 1.27 cm)

**Estimate: \$4,000 - 8,000**

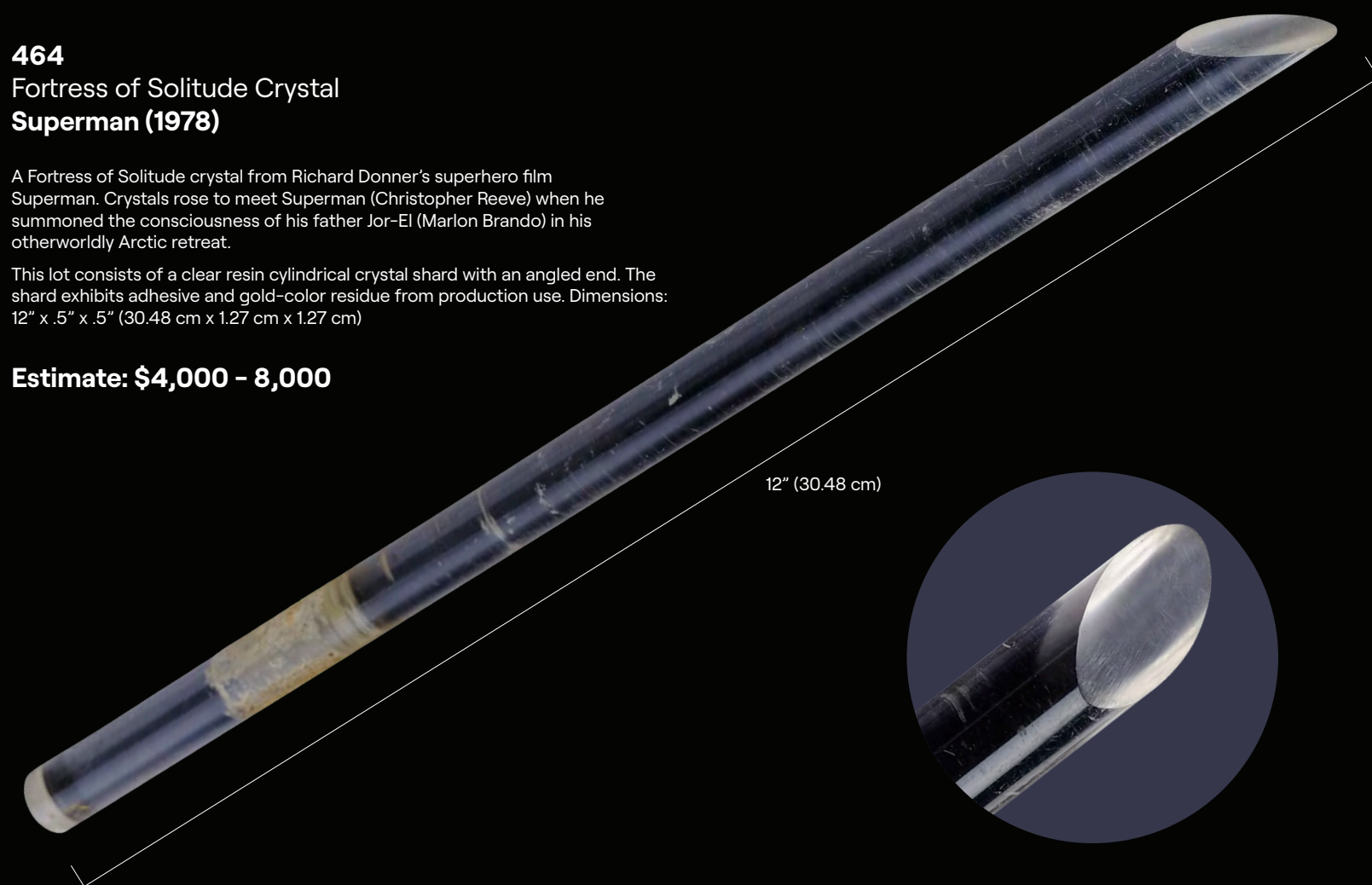

12" (30.48 cm)







**465**  
Screen-Matched Superman/Clark Kent (Christopher Reeve) Photobooth Photos **Superman III (1983)**

Screenmatched Superman/Clark Kent (Christopher Reeve) photobooth photos from Richard Lester's superhero sequel Superman III. During the film's opening, Clark Kent ran into a photobooth, which captured his transformation into Superman, so he tore off the bottom photo and handed it to a child. This lot screen-matches to close-up shots of the torn photo strip in the film through the slightly askew angle of the top photo, a small print error on Superman's neck in the torn-off bottom photo, and the finer details of the tear itself.

Printed on glossy paper, the four black-and-white photos show Kent removing his glasses and civilian clothing to reveal his superhero costume underneath. Each photo is surrounded by a thin black border, and the bottom of the strip is intentionally torn. The upper-left corner of the torn section has bent slightly over time and the strip exhibits very light edge wear. Dimensions (largest): 6" x 1.75" (15 cm x 4.5 cm); (smallest): 2" x 1.75" (5 cm x 4.5 cm)

**Estimate: \$7,000 - 14,000**

**466**  
Lenny Luthor's (Jon Cryer) Jacket and Trousers **Superman IV: The Quest For Peace (1987)**

Lenny Luthor's (Jon Cryer) jacket and trousers from Sidney J. Furie's superhero sequel Superman IV: The Quest for Peace. Lenny wore his distinctive jacket and trousers when he broke his uncle Lex (Gene Hackman) out of prison, and drove two prison guards off a cliff in a remote-control car.

The jacket features a shiny leopard-face design with a pearlescent finish. Its two breast pockets form the leopard's eyes. The trousers are styled to look like reptile skin with a golden finish. Each item contains a Berman's & Nathan's label, which reads "John Cryer [sic] 5198 cost. 4. Superman IV". The clothes exhibit some wear from production use, including plucked stitching and some scuffing on the trousers.

**Estimate: \$7,000 - 14,000**



Cape Back

**467**  
Supergirl's (Helen Slater) Tunic with Replica Components **Supergirl (1984)**

Supergirl's (Helen Slater) tunic from Jeannot Szwarc's superhero film Supergirl with replica components. Supergirl wore her signature tunic throughout the film.

This blue nylon stretch fabric tunic was specifically created for the film's flying sequences. It features the classic red-and-yellow appliqued "S" emblem and four large black poppers sewn onto the shoulders where the cape was attached during filming. Multiple strips of self-fasteners are adhered throughout, and four red cotton harness attachments with additional popper fastenings adorn the back. A label on the interior neckline is hand-marked "Left Shoulder. Fro, 167, 7"

Also included are a replica canvas cape, a replica matching skirt, and a replica leather belt added to complete the costume, as well as a 11" x 14" (28 cm x 35.5 cm) color photograph autographed in blue marker by Helen Slater. Production intentionally distressed this tunic, and it additionally exhibits mild discoloration, notable stitches, and snagged and loose threads.

**Estimate: \$7,000 - 14,000**



**468**  
Dean (Jensen Ackles) and Sam Winchester's (Jared Padalecki) Stunt Guns **Supernatural (2005-2020)**

Dean (Jensen Ackles) and Sam Winchester's (Jared Padalecki) stunt guns from the dark fantasy series Supernatural. Dean and Sam used their preferred handguns throughout the series.

This lot consists of two silver-color foam rubber stunt guns. One features a custom M1911A1 design with an engraved slide and ivory-color resin grips, the other features a Taurus PT92AFS design with pearlescent white resin grips. Also included is a gray plastic, foam-lined gun case. This lot exhibits flaked paint and minor cracks and pitting in the foam. Dimensions: 11" x 9" x 3" (28 cm x 23 cm x 7.75 cm)

Ownership may be restricted in some countries; see replica firearm notice in Buyer's Guide.

**Estimate: \$10,000 - 20,000**



**469**  
Alec Baldwin  
(Maurice LaMarche) Puppet  
**Team America: World Police**  
**(2004)**

An Alec Baldwin (Maurice LaMarche) puppet from Trey Parker's puppet comedy *Team America: World Police*. Baldwin spoke on the news about the Film Actors Guild being against the actions of the World Police.

Created by the Chiodo Brothers, this ornately hand-painted, cotton-padded fiberglass puppet features a thin foam face and limbs, blue acrylic eyes inset, brown synthetic hair, eyebrows, and eyelashes, dark cloth clothing, and resin shoes painted black. Also included are wires and a control bar created to operate the puppet's facial features. Conservation work was performed on the face by Tom Spina Designs, though the material remains extremely fragile. The boots also exhibit chipped paint. Dimensions: 24" x 9" x 5" (61 cm x 23 cm x 12.75 cm)

Contains mechanical components; see notice in the Buyer's Guide.

**Estimate: \$30,000 - 60,000**

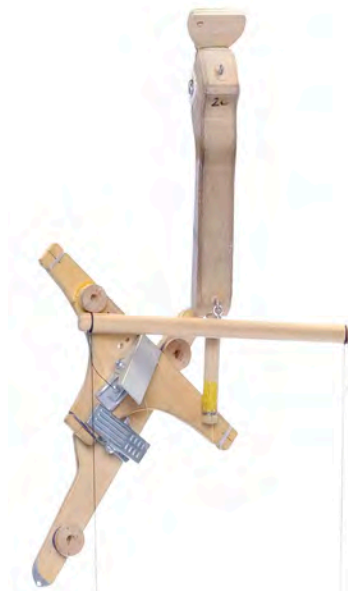

24" (61 cm)



**470**  
**Matt Damon (Trey Parker and Matt Stone) Puppet**  
**Team America: World Police**  
**(2004)**

A Matt Damon (Trey Parker and Matt Stone) puppet from Trey Parker's puppet comedy Team America: World Police. Damon appeared on the news as one of the Film Actors Guild members to attend an emergency meeting.

Created by the Chiodo Brothers, this ornately hand-painted fiberglass puppet features a thin foam face and limbs, blue acrylic eyes inset, brown synthetic hair, eyebrows, and eyelashes, dark cloth clothing, and resin boots painted black. Also included are wires and a control bar created to operate the puppet's facial features. Conservation work was performed on the face by Tom Spina Designs, though the material remains extremely fragile. The boots also exhibit chipped paint. Dimensions: 24" x 9" x 5" (61 cm x 23 cm x 12.75 cm)

Contains mechanical components; see notice in the Buyer's Guide.

**Estimate: \$30,000 - 60,000**



24" (61 cm)



RGR Collection / Alamy Stock Photo

**471**  
**Gary Johnston (Trey Parker) Puppet**  
**Team America: World Police**  
**(2004)**

A Gary Johnston (Trey Parker) puppet from Trey Parker's puppet comedy Team America: World Police. Gary was recruited to join the World Police and help them save the world from Kim Jong Il (Parker).

Created by the Chiodo Brothers, this ornately hand-painted fiberglass puppet features a thin foam face and limbs, blue acrylic eyes inset, brown synthetic hair, eyebrows, and eyelashes, dark cloth clothing, and resin boots painted black. Also included are wires and a control bar created to operate the puppet's facial features. Conservation work was performed on the face by Tom Spina Designs, though the material remains extremely fragile. The boots also exhibit chipped paint. Dimensions: 24" x 9" x 5" (61 cm x 23 cm x 12.75 cm)

Contains mechanical components; see notice in the Buyer's Guide.

**Estimate: \$30,000 - 60,000**



24" (61 cm)



27" (68.75 cm)

**472**  
**Gary Johnston's (Trey Parker) Motorcycle Model Miniature**  
**Team America: World Police (2004)**

Gary Johnston's (Trey Parker) motorcycle model miniature from Parker's puppet comedy Team America: World Police. Gary rode his motorcycle across America on his way back to Team America headquarters.

This lot consists of a red, gray, and chrome-painted urethane motorcycle model featuring reflective lights, headlights, and tail lights, a black plastic seat textured to resemble leather, black rubber wheels, and a blue and yellow "NEW BRIGHT" license plate. This motorcycle remains balanced upright with a metal bracket on the underside with two black dense urethane wheels that cover a battery pack compartment. This lot exhibits minor paint chipping and is nonfunctional. Dimensions: 27" x 8.5" x 12.5" (68.75 cm x 21.75 cm x 31.75 cm)

Contains electronics; see electronics notice in the Buyer's Guide.

**Estimate: \$10,000 - 20,000**

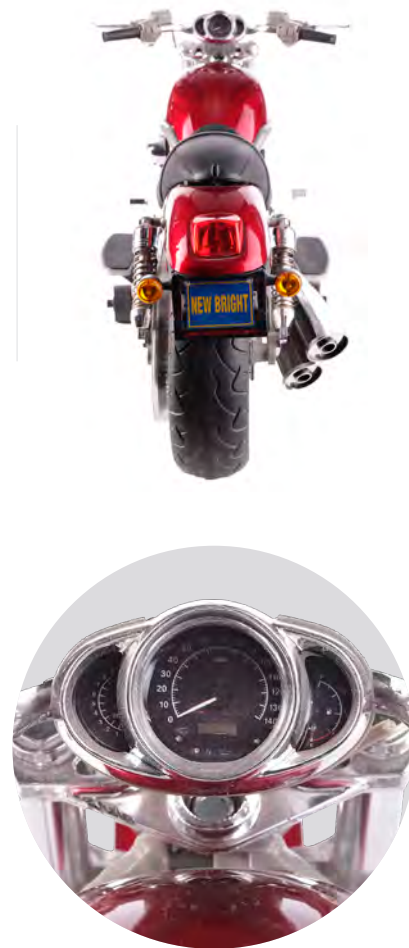

**473**  
**Camel Puppet**  
**Team America: World Police**  
**(2004)**

A camel puppet from Trey Parker's action-comedy film Team America: World Police. Camel puppets were used while the World Police infiltrated a village in Cairo.

This lot consists of a shaved faux fur camel with a foam and metal base, a painted foam face, synthetic hair eyelashes and tail, acrylic eyes, and brown painted resin feet. Included are the strings and black painted control bars to move the puppet. Wires are accessible through the abdomen that connect to components within the head and it is controlled by a battery operated remote controller. This lot exhibits fragile material on the face and minor splitting wood on the control bars. Dimensions: 32.5" x 29.5" x 10" (82.75 cm x 75 cm x 25.5 cm)

Contains mechanical and electrical components; see notice in the Buyer's Guide.

**Estimate: \$10,000 - 20,000**

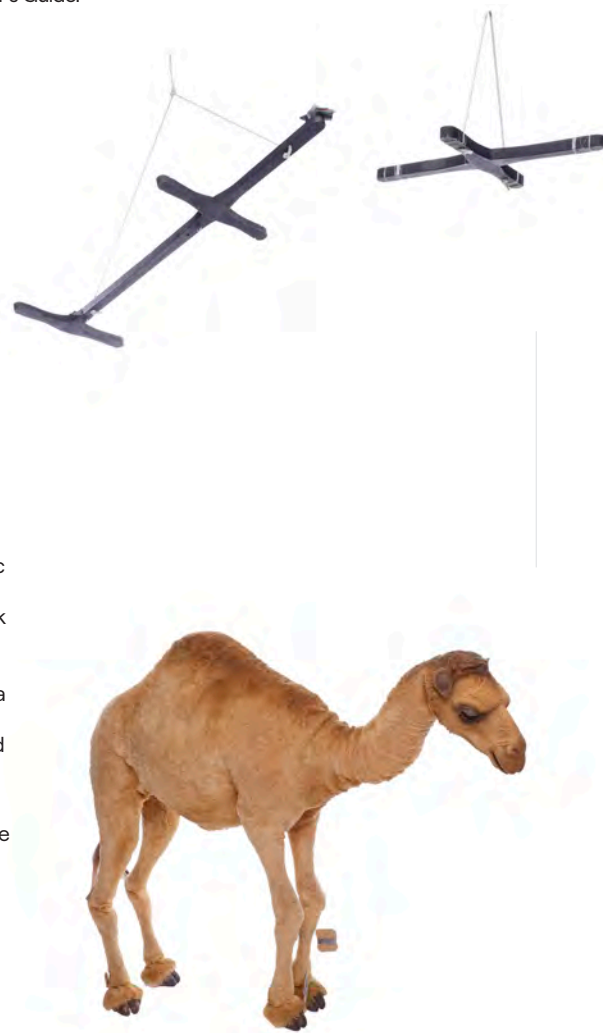

22" (56 cm)



**474**  
**Comic-Con Ted Lookalike Bear**  
**Ted 2 (2015)**

A Comic-Con Ted lookalike bear from Seth MacFarlane's comedy sequel Ted 2. Ted (MacFarlane) hid amongst lookalike teddy bears at New York Comic-Con to avoid being caught by Donny (Giovanni Ribisi).

This hollow, fiber-filled teddy bear features tawny polyester "fur," brown-rimmed black acrylic eyes, a black plastic nose, and pads in the feet that allow it to stand. It exhibits some fraying and staining to the fur, most visibly around its mouth. Dimensions: 22" x 18" x 10" (56 cm x 45.75 cm x 25.5 cm)

**Estimate: \$10,000 - 20,000**



**475**  
**T-800 (Arnold Schwarzenegger) Bust**  
**Terminator 2: Judgment Day (1991)**

A T-800 (Arnold Schwarzenegger) bust from James Cameron's sci-fi sequel Terminator 2: Judgment Day. Stan Winston Studio created detailed busts for SFX inserts that could not be accomplished with live performers, including for the climactic smelting plant sequence.

This bust is constructed from foam flesh molded over a metalized dense rubber endoskeleton, inset with a red eye, dressed with brown lace-wig hair mirroring the film-used versions created by Stan Winston Studio, and affixed with matching synthetic eyebrows and eyelashes. Its skin is painted to appear bullet-riddled, blood-stained, and scarred with its chrome endoskeleton exposed. The bust is outfitted with the tops of a heavily distressed black leather jacket, gray cotton T-shirt, and black nylon shoulder strap to complete the display. Internal wiring designed to illuminate the eye was cut following production, rendering it nonfunctional, and the foam's painted finish exhibits some scuffing. Dimensions: 16" x 10" x 17" (40.75 cm x 25.5 cm x 43.25 cm)

Contains electronic components; see notice in the Buyer's Guide.

**Estimate: \$20,000 - 40,000**

**476**  
**The Terminator's (Arnold Schwarzenegger) Costume**  
**Terminator 2: Judgment Day (1991)**

The Terminator's (Arnold Schwarzenegger) costume from James Cameron action sequel Terminator 2: Judgment Day. The Terminator wore his signature costume throughout the film after stealing it at a biker bar, before ultimately sacrificing itself in the steel mill to prevent Judgment Day.

This costume is composed of a gray T-shirt accompanied by a brown leather belt and black faux leather trousers. The shirt features a zipper at the nape of the neck, and the trousers feature zippers at the ankles. Production intentionally distressed the belt. This costume exhibits cracking, peeling, and flaking pleather from the trousers.

**Estimate: \$8,000 - 16,000**





**477**  
**TX's (Kristanna Loken) Costume with Light-Up Display**  
**Terminator 3: Rise Of The Machines (2003)**

TX's (Kristanna Loken) costume with a light-up display from Johnathan Mostow's sci-fi action sequel Terminator 3: Rise of the Machines. A cyborg assassin from the future, the TX wore the costume she acquired from an innocent bystander on her mission to kill John Connor (Nick Stahl).

Designed by April Ferry, this costume featured in promotional materials and throughout the film. It consists of a burgundy jacket and pants made from crocodile-textured faux leather; a purple nylon mesh leotard; and brown leather boots with silver-color high heels. It comes presented on a foam-padded peach-color fiberglass mannequin with a metal and resin replica head equipped with wired facial features designed to illuminate via a power plug on the back. The foam elements exhibit extensive wear and the head is cracked from handling. Dimensions (displayed): 10" x 26" x 70" (28.5 cm x 66 cm x 178 cm)

Contains electronics; see notice in the Buyer's Guide.

Special shipping required; see notice in the Buyer's Guide.

**Estimate: \$10,000 - 20,000**



**478**  
**T-800's (Arnold Schwarzenegger) Battle-Damaged**  
**Costume and Endoskeleton Appliances**  
**Terminator 2: Judgment Day (1991)**

T-800's (Arnold Schwarzenegger) battle-damaged costume and endoskeleton appliances from James Cameron's sci-fi sequel Terminator 2: Judgment Day. Battle-damaged bodies were created for insert shots that could not be achieved with live performers, including for the smelting scene.

This lot consists of a foam chest appliance molded over a metal armature with internal wiring; a two-piece foam knee appliance with exposed endoskeleton at front; a purple cotton T-shirt; and a pair of camouflage pants. This piece, having been pulled apart, is extensively cracked, torn, and discolored by production to appear severely burned, and the lot remains fragile from production use and age. Dimensions: 66" x 26" x 12" (167.75 cm x 66 cm x 30.5 cm)

Special shipping required; see notice in the Buyer's Guide.

**Estimate: \$4,000 - 8,000**

**480**  
**Sam's (Quinn Lord) Burlap Gloves with VFX Glove**  
**Trick 'R Treat (2007)**

Sam's (Quinn Lord) burlap gloves with a VFX glove from Michael Dougherty's horror anthology Trick 'r Treat. Sam wore his gloves throughout the film, including his own segment, "Sam," where he terrorized the ill-tempered Mr. Kreeg (Brian Cox).

Originating with a member of the crew, this lot consists of a pair of gloves. Composed of a pair of knit cotton socks with the ends cut off and a hole cut for the thumb, these gloves feature an outer burlap cover stitched together to keep shape. One features twine wrapped around the wrist. Also included is a blue spandex-blend fingerless VFX glove used to digitally remove Sam's hand after it was cut off. Production intentionally distressed the burlap gloves, and they exhibit discoloration and loose fibers.

**Estimate: \$5,000 - 10,000**

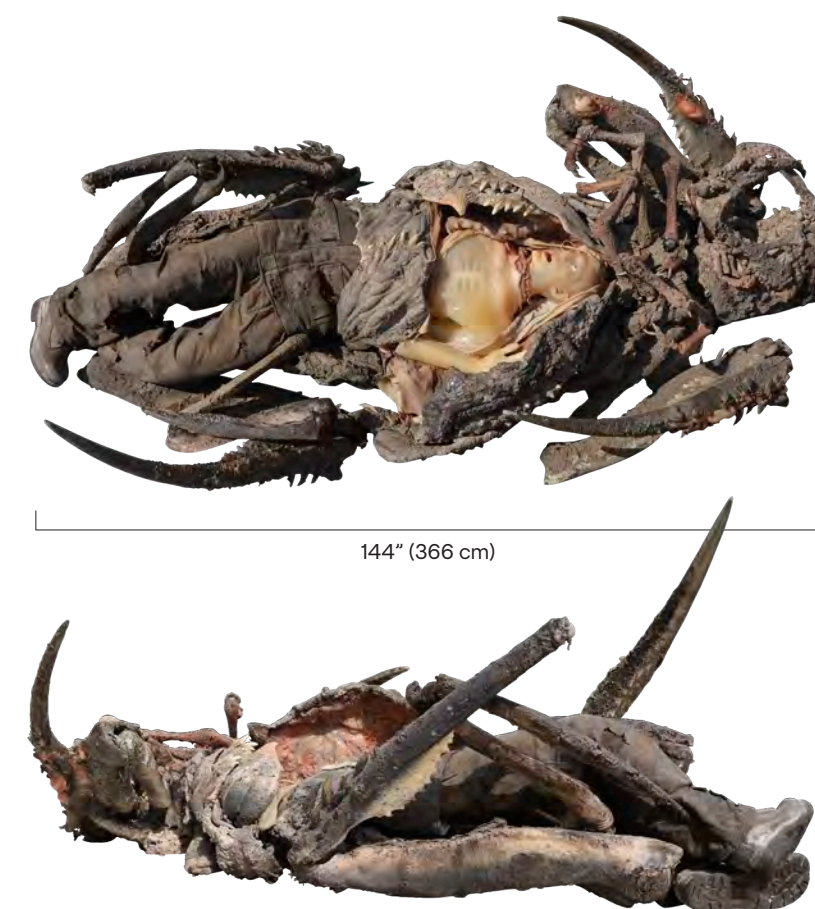

**479**  
**Henrik-Thing Autopsy Body**  
**The Thing (2011)**

A Henrik-Thing autopsy body from Matthijs van Heijningen Jr.'s sci-fi horror film The Thing. The scientists at Thule performed an autopsy on the Henrik-Thing after they killed it with a flamethrower for absorbing Henrik (Jo Adrian Haavind).

Designed and created by studioADI, this lot consists of a large sculpture of a charred Thing and a replica human body. Made of plastic and foam with an internal metal armature, latex and silicone, this sculpture relied on practical effects and a contrast of textures to convey a once living alien, complete with translucent, wet insides. Only the Henrik replica body was digitally painted over. This lot exhibits grime from age; cracked latex; exposed joints and foam; and also fragile and broken appendages. Dimensions: 144" x 67.25" x 60" (366 cm x 171 cm x 152.5 cm)

Special shipping required; see notice in the Buyer's Guide.

**Estimate: \$5,000 - 10,000**



**481**  
Norris (Charles Hallahan) Spider Head-Thing  
**The Thing (1982)**

A Norris (Charles Hallahan) Spider Head-Thing from John Carpenter's sci-fi horror film *The Thing*. After R.J. MacReady (Kurt Russell) burned the Norris-Thing, Norris' head detached from the body to survive the fire and transformed into a spider-like monster. The primary mechanical spider-head puppet seen in the film was burned on camera, but a few static props were also made during production.

Designed by special effects makeup artist Rob Bottin, this static version of the Spider Head-Thing was gifted by Bottin to Henry Alvarez, a sculptor who worked on the film, at the time filming wrapped. This piece is very similar to the one seen on the cover of a special double issue of *Cinefantastique* for "The Incredible Effects of *The Thing*," though the legs on the *Cinefantastique* prop had added spikes that were never seen in the film versions.

Originally obtained from the family of Alvarez, the head is made of dense latex and foam based on a sculpture bearing Charles Hallahan's likeness with life-like resin eyes. It features welded metal armatures inside the six spider-like legs; the armatures are covered with latex skins. A replica lace wig with synthetic hair has been added for display. Also included is a copy of the referenced *Cinefantastique* magazine.

*The Thing* was not a critical success upon its release, but has been reevaluated over time and is now widely considered a staple title in the horror genre. Rob Bottin's effects work, especially on *The Thing*, is regularly lauded as an amazing practical effects achievement even by today's standard. Bottin won a Special Achievement Academy Award in 1991 for *Total Recall*, and later withdrew from the film industry. Original Bottin pieces in the collecting world are both scarce and sought after. This is one of the most significant Rob Bottin effects pieces ever offered at public auction.

The head has had minor restoration and stabilization work done. This lot exhibits discoloration, cracked and fragile latex from age; exposed foam and metal around the head; and lifted adhesive from age. Dimensions: 48" x 36" x 48" (122 cm x 91.5 cm x 122 cm)

**Estimate: \$100,000 - 200,000**



Cinefantastique Magazine  
Published by Frederick S. Clarke.





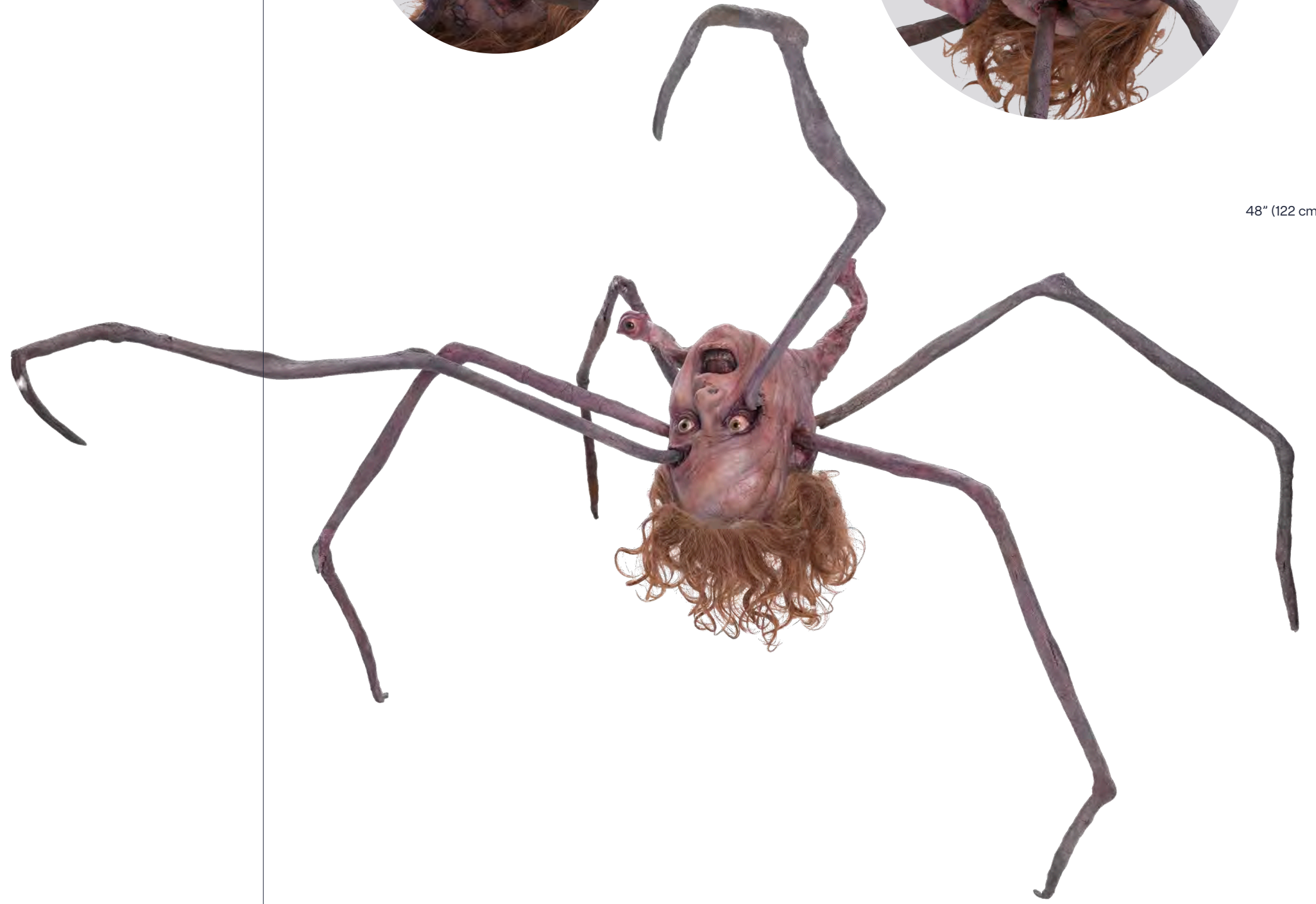

48" (122 cm)

48" (122 cm)



Album / Alamy Stock Photo

**482**  
Rose DeWitt Bukater's (Kate Winslet) Sinking Coat  
**Titanic (1997)**

Rose DeWitt Bukater's (Kate Winslet) sinking coat from James Cameron's romantic drama Titanic. Rose wore her coat as crew members aboard the Titanic informed passengers to put on their life belts and when she went to save Jack Dawson (Leonardo DiCaprio) from drowning in the lower level holding area.

Due to the nature of the scene where the piece would be submerged in a water tank for hours at a time, production produced several copies of Bukater's sinking coats for use throughout production. This particular coat consists of a pink wool- and polyester-blend coat with black embroidery along the collar and cuffs; black thread woven buttons over the chest; and one production tag. Included in this lot is a Certification of Authenticity from Twentieth Century Fox. This lot exhibits minor discoloration.

**Estimate: \$100,000 - 200,000**



Official Twentieth Century Fox Certificate





**483**  
**Engine Room Workers Coveralls**  
**Titanic (1997)**

Engine room workers coveralls from James Cameron's romantic drama film Titanic. Workers wore their coveralls as they shoveled coals into the ship's boilers.

This lot consists of gray wool herringbone coveralls labeled "TITANIC"; a black-painted metal oil can; a brown microfiber handkerchief wrapped in white Titanic-themed tissue paper; and a brown leather belt with a brass-color metal buckle. Included with this lot is an Eastern Costume Company Certificate of Authenticity signed by vice president Breanna Livie. This lot exhibits intentional distressing on the coveralls and handkerchief, and chipping paint and dents on the oil can. Dimensions: 5' x 3" x 10" (12.75 cm x 7.75 cm x 25.5 cm)

**Estimate: \$8,000 - 16,000**



**484**  
**Hollywood (Whip Hubley)**  
**and Wolfman's (Barry Tubb)**  
**F-14A Tomcat**  
**Pyrotechnic Model Miniature**  
**Top Gun (1986)**

Hollywood (Whip Hubley) and Wolfman's (Barry Tubb) F-14A Tomcat pyrotechnic model miniature from Tony Scott's action film Top Gun. Top Gun was highly regarded for its aerial combat sequences, which utilized a mixture of live-action photography of actual F-14 jets, and visual effects work with models of various scales. In the film's climactic battle sequence, the F-14 piloted by "Hollywood" and "Wolfman" was shot down by an enemy MiG.

The shots of the F-14 being hit by the MiG's missile were achieved with "pyro" models approximately 6' in length, and practical explosion effects. Two shots appear in the film—the first is an explosion shot where the missile impacts and a charge is set off, blowing off a rear section of the aircraft; this was done with a model miniature mounted on a pole arm through its wing. The model offered in this lot was used in the second shot, which sees Hollywood and Wolfman's F-14 falling out of the sky while ablaze. The shot was achieved by dropping the flaming model from a large man-lift. It was shot from underneath, and the model was caught in a net. Behind-the-scenes footage of the shot exists in a documentary on the film's effects. After the first take, the model crew cleaned up the piece for a possible second attempt; it was deemed not necessary as the first shot was approved.

This is one of the few 6'-scale models that survived the shoot. It is cast in fiberglass around a wood structure, and detailed with emblems and markings that match the full-size jets used in filming. The canopy window is made of thin plastic which covers a pair of hand-painted miniature pilots affixed with helmets labeled 'YES' and 'NO' (an in-joke from the model crew, knowing the helmets would never be seen in detail on film.) Its nose is hand-numbered "114," the same number on Pete "Maverick" Mitchell's (Tom Cruise) F-14, which was applied to all models used in the shoot. The model is missing a large section from its rear that represents the missile impact in the shot.

This model exhibits signs of age and wear, including a large section of the starboard quarter deliberately removed by production as well as several cracks throughout the body and yellowing on the canopy window plastic. Dimensions: 73" x 64" x 21" (185.5 cm x 162.5 cm x 53.5 cm)

Special shipping required; see notice in the Buyer's Guide.

**Estimate: \$20,000 - 40,000**



Behind-the-scenes footage of pyro model dropped from a boom lift to achieve the shot.

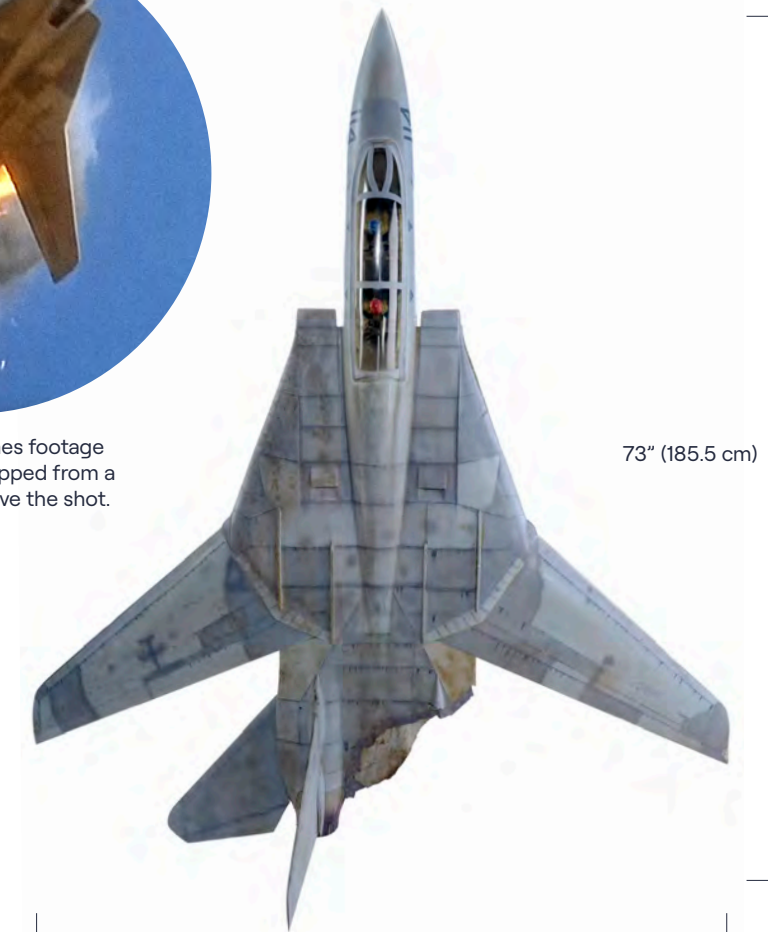

73" (185.5 cm)

64" (162.5 cm)



**485**  
 Pete "Maverick" Mitchell's (Tom Cruise)  
 F-14A Tomcat Model Miniature  
**Top Gun (1986)**

Pete "Maverick" Mitchell's (Tom Cruise) F-14A Tomcat model miniature from Tony Scott's action drama *Top Gun*. *Top Gun* was highly regarded for its aerial combat sequences, which utilized a mixture of live-action photography of actual F-14 jets, and visual effects work with models of various scales. Maverick flew his Grumman F-14 Tomcat at the Naval Air Station Miramar.

Mounted on a black-painted wood base, this model miniature is built from light- and dark gray-painted fiberglass with Maverick's plane number "114" and "NAVY" stenciled on the body. It features a urethane cockpit canopy window affixed above hand-painted miniature models of Maverick and Hazumi, both stationed with labeled helmets in urethane seats via attachment mounts. The miniature exhibits several points of sympathetic repair, as well as grime, faded stenciling from age, wobbling to the base. Dimensions: 23" x 16" x 5" (58.5 cm x 40.75 cm x 12.75 cm)

**Estimate: \$8,000 - 16,000**

**486**  
 Identity Disc  
**Tron (1982)**

An identity disc from Steven Lisberger's sci-fi adventure *Tron*. Computer programmer Kevin Flynn (Jeff Bridges) was transported by the Master Control Program into a digital "Game Grid," where he and his fellow programs were issued discs to be used for identification and combat.

This hand-painted foam rubber disc with textured ridges is painted off-white and affixed with black tape detailing. The unpainted back has fastening strips for attaching to the back of the performer's costume. The disc exhibits significant signs of production use and age, including visibly cracked rubber, paint, and glue residue on the reverse, and torn fastening strips. Dimensions: 8.5" x 8.5" x 0.5" (21.75 cm x 21.75 cm x 1.25 cm)

**Estimate: \$8,000 - 16,000**



**487**  
 Achilles' (Brad Pitt) Bronze Sword  
**Troy (2004)**

Achilles' (Brad Pitt) bronze sword from Wolfgang Petersen's mythical epic *Troy*. Achilles wielded his sword throughout the film, using it during his dispatching of Boagrius (Nathan Jones), in his battles against the Trojan Apollonians, and in his duel with Hector (Eric Bana).

This sword features a curved, leaf-shaped bronze blade decorated with inlays extending from its black solid-cast resin handle. There are holes at each corner of the grip, giving the illusion of rivets, and a ridge runs down the center of the blade to just below the tip. Also included is a bespoke display stand, made in the production's workshop, which features a marble-like stone base, with the film's title artwork painted in gold-color. Green paint has been applied to the handle and bottom of the blade to create the appearance of a verdigris patina, and the weapon has been intentionally distressed to look battle-worn. It exhibits additional signs of wear from use and age, including scuffing to the finish of the sword and base. Dimensions: (displayed) 8.25" x 5.25" x 30" (21 cm x 13 cm x 76 cm)

Blade was dulled by production.

**Estimate: \$15,000 - 30,000**



**488**  
**Achilles' (Brad Pitt) Shield**  
**Troy (2004)**

Achilles' (Brad Pitt) shield from Wolfgang Petersen's mythical epic Troy. The Greek warrior wielded his shield throughout the film, notably using it alongside his sword during the beach battle sequence in which he slaughtered many Trojan soldiers and confronted Hector (Eric Bana) inside the Temple of Apollo.

Made of biscuit foam, the shield is round with two semi-circular cut-outs on opposing sides, which allowed Achilles to thrust with a spear while still protecting himself. Finished in black and faux-bronze paint, the face of the shield features intricate figures at war around the center, with eight discs situated above them. A black wooden handle is affixed to the rear, alongside a strip of thick leather binding and four faux-gold rings. Signs of production use are present on the lot, including light scuffs around the edge and minor paint wear. Dimensions: 32" x 32" x 4.25" (81.5 cm x 81.5 cm x 11 cm)

**Estimate: \$20,000 - 40,000**



32" (81.5 cm)



Reverse Side

**489**  
Paris' (Orlando Bloom)  
Bow, Quiver, and Arrows  
Troy (2004)

Paris' (Orlando Bloom) bow, quiver, and arrows from Wolfgang Petersen's mythical epic Troy. Paris used his bow and arrows to shoot and kill the legendary Greek warrior Achilles (Brad Pitt).

This lot consists of a bow, quiver, and four arrows. The wooden bow is covered in vellum and a dark green leather grip with hand-stitched detailing. The ends of the longbow are finished in gold-color paint and resemble a bird with a black beak. The black leather quiver features a thin leather strap and decorative cream pieces with hand-stitching. One side features a decorative pouch with a scale pattern. A gold-color wooden ring is adhered near the top. Four wooden arrows with gray fletching and darkened blunt ends come with the quiver. This lot exhibits notable paint marks, scratches, scuffs, and mild discoloration. Dimensions: 64.5" x 8" x 4" (164 cm x 20 cm x 10 cm)

Special shipping required; see notice in the Buyer's Guide.

**Estimate: \$10,000 - 20,000**



Handle Detail

Tip Detail

**490**  
Paris' (Orlando Bloom) Shield  
Troy (2004)

Paris' (Orlando Bloom) shield from Wolfgang Petersen's mythical epic Troy. Paris used his shield while he fought for Helen's (Diane Kruger) hand against her husband Menelaus (Brendan Gleeson) outside the walls of Troy.

Made of resin and fiberglass, the shield front is decorated with three pairs of raised horse emblems, and has a vinyl-like fabric with fret cut patterns around its outside edge. The back of the shield is padded to provide comfort for the actor, and features a wooden handle alongside four gold-color metal rings. Production intentionally distressed this shield to look battle-worn. This lot exhibits minor wear around the edges, light scuffs at its center, and marks on the back. Dimensions: 35.5" x 35.5" x 4.5" (90 cm x 90 cm x 11 cm)

**Estimate: \$6,000 - 12,000**



Reverse Side



**491**  
Menelaus' (Brendan Gleeson) Bloodied Bronze Sword  
Troy (2004)

Menelaus' (Brendan Gleeson) bronze sword from Wolfgang Petersen's historical epic Troy. Menelaus used his signature sword while fighting Paris (Orlando Bloom), his wife's Helen (Diane Kruger), outside the walls of Troy.

This sword features a solid bronze blade; a dense cast rubber grip with a fishtail-style pommel painted black to appear wooden; and distinctive raised rivet-like details on the handle's top and pommel's underside. The blade exhibits intentional distressing by production with scratches, nicks, and blood stains to appear battle-damaged, and a rivet is missing from the pommel. Dimensions: 28.75" x 3.25" x 1.75" (72.5 cm x 8 cm x 4 cm)

**Estimate: \$4,000 - 8,000**



**492**  
Hector's (Eric Bana) Double Death Armour  
Troy (2004)

Hector's double death armor from Wolfgang Petersen's historical epic Troy. Hector wore his armor as he battled and ultimately lost to Achilles (Brad Pitt).

It is made of vinyl with leather lacing, leather-lined throughout for comfort, and finished in a metallic gold-color paint. Inside it has two labels, marked "DBL Hector" and "DBL Hec." It has been intentionally distressed and exhibits a hole in the left shoulder where Achilles plunged his spear.

**Estimate: \$3,000 - 6,000**





**493**  
Bella Swan's Hooded Jacket  
**Twilight (2008)**

Bella Swan's hooded jacket from Lionsgate's fantasy-romance blockbuster hit *Twilight*. Bella wore her jacket when Edward Cullen saved her from a car accident and when they first arrived at school together as a sign of their relationship status.

This brown wool and polyester blend jacket (size XS) marked "TW" in black marker features a brown button closure with a brown polyester lining and a white polyester sherpa-lined hood. This jacket exhibits no signs of production use.

**Estimate: \$8,000 - 16,000**



**494**  
Bella Swan's Marketing Photos Costume  
**The Twilight Saga: Eclipse (2010)**

Bella Swan's marketing photos costume from Lionsgate's blockbuster hit *The Twilight Saga: Eclipse*. Bella wore her costume in the marketing and promotion for the film's release.

This lot consists of a gray cotton hooded sweatshirt (size 1); a faded purple poly-cotton shirt (size medium); gray cotton jeans (size W26 L35) marked "EC Bella"; and a pair of navy canvas shoes with rubber soles (size 7) marked "NW Bella." The costume exhibits minimal signs of wear.

**Estimate: \$6,000 - 12,000**



**495**  
Bella Swan's Cafeteria Costume  
**Twilight (2008)**

Bella Swan's cafeteria costume from Lionsgate's blockbuster hit *Twilight*. Bella wore her costume in the Forks High School cafeteria when she dropped an apple and Edward Cullen caught it before discussing his secret identity.

This lot consists of a brown, cinched cotton blouse decorated with white floral embroidery over the chest and shoulders labeled "Bella"; a maroon cotton-blend tank top; green cotton corduroy trousers with several button-secured pockets lining them; and blue suede slip-on shoes. All pieces of this costume are labeled "TW." The shoes exhibit some scuffs and stains on the toe caps.

**Estimate: \$7,000 - 14,000**



**496**  
Bella Cullen's Final Battle Costume  
**The Twilight Saga: Breaking Dawn-Part 2 (2012)**

Bella Cullen's (Kristen Stewart) final battle costume from Lionsgate's blockbuster hit *The Twilight Saga: Breaking Dawn - Part 2*. Bella wore her costume during the bonfire and the epic final battle between the Olympic coven and the Volturi.

This costume consists of a double-breasted green leather jacket with a flap collar and zipper and button closures; a sheer green cotton tank top with spaghetti straps; black and gray rayon-nylon blend leggings; and gray leather high-heeled lace-up boots with woven fabric at the ankles. The costume exhibits signs of production wear, including cracked leather, scuffs, and grime to the undersides of the boots, along with frayed shoelaces.

**Estimate: \$6,000 - 12,000**





**497**  
**Male Nurse's "Eye of the Beholder" Makeup Appliance**  
**The Twilight Zone (1959-1964)**

A male nurse's "Eye of the Beholder" makeup appliance from Rod Serling's classic sci-fi series The Twilight Zone. In the iconic Season 2 episode "Eye of the Beholder," pig-faced nurses caring for Janet Tyler (Maxine Stuart) were repulsed to discover she had altered her once-perfect porcine appearance.

The "pig face" appliances were created by prolific Hollywood makeup artist William Tuttle. This piece has been lovingly preserved for over 60 years by the family of makeup artist Grant "Bob" Keate, who worked on the episode and retained it as a memento. This appliance is made from foam latex hand-painted in two tones of fleshy pink. A modern copy of a photograph of Keate applying makeup for the episode is included, along with three vintage black-and-white photographs of Keate applying the Gremlin's (Nick Cravat) makeup appliance for the episode, "Nightmare at 20,000 Feet." Original artifacts from this beloved show are extremely scarce; this piece is fresh-to-market and carries crew member provenance. The appliance is in delicate condition with cracking, stiffening, discoloration, and should be handled with care.  
 Dimensions: 3" x 3.5" x 2" (7.75 cm x 9 cm x 5 cm)

**Estimate: \$8,000 - 16,000**



**498**  
**Violet's (Milla Jovovich) End Scene Costume**  
**Ultraviolet (2006)**

Violet's (Milla Jovovich) end-scene costume from Kurt Wimmer's sci-fi action film Ultraviolet. Violet wore her costume when she fought off numerous guards to rescue Six (Cameron Bright) and battled Daxus (Nick Chinlund).

The red costume consists of a leather jacket, a Lycra zip-up top, a pair of trousers with decorative leather panels, gloves, and knee-high heeled boots. Sections of nylon and satin-like fabric have been incorporated into the jacket, with four plastic poppers adhered to the inside of the collar and outside of the top. The inside of the jacket and waistband are labeled "M" for Milla, the boots display the letter "Y" and the gloves feature the text "Y Double" for Youlia Galenko, Jovovich's stunt double. The costume displays multiple marks and has been intentionally distressed, with paint applied to produce a burnt appearance.

**Estimate: \$4,000 - 8,000**

**499**  
**Selene's (Kate Beckinsale) Overcoat**  
**Underworld (2003)**

Selene's (Kate Beckinsale) overcoat from Len Wiseman's action horror film Underworld. Selene wore her overcoat over her catsuit throughout the film.

This lot consists of a black leatherette coat lined with black polyester. It features decorative stitching along the collar, sleeves, and bottom hem. The collar has two bendable wires at the edges to keep its shape. Also included is a Letter of Authenticity from and signed by co-writer and co-creator Danny McBride. This costume exhibits some discoloration, loose threads and seams, and some surface scratches.

**Estimate: \$3,500 - 7,000**



**500**  
Viktor's (Bill Nighy) Purple Overcoat  
**Underworld (2003)**

Viktor's (Bill Nighy) purple overcoat from Len Wiseman's action horror film Underworld. Viktor wore his purple overcoat into the Lycan's underground lair during the final showdown.

Composed of purple faux leather lined in satin with a velvet sleeve lining, this floor-length coat features entwined metal embellishments along the standing collar, and across the shoulder's front and back. The outer sleeves feature similar entwined embroidery at the bottom. The coat train also has gussets at the back for added flair during action sequences. The interior of the overcoat features a frog to hold Viktor's sword. This lot exhibits some metal fragility, discoloration, and mildew residue.

**Estimate: \$4,000 - 8,000**



**501**  
Victor's (Bill Nighy) Sword  
**Underworld (2003)**

Victor's (Bill Nighy) sword from Len Wiseman's action horror film Underworld. Victor used his sword in the final battle before Selene (Kate Beckinsale) beheaded him with it.

This lot consists of a polyurethane sword. Painted with a mirror-like chrome-color, this sword features a unique hilt with a divot on one side to accommodate Nighy's hand grip. The grip is covered in a diamond-patterned brown leatherette. The guard and pommel feature intricate engravings with a decorative embossed "V" on both sides of the pommel. Also included is a Letter of Authenticity from and signed by co-writer and co-creator Danny McBride. This sword exhibits chipped paint, notable paint marks, notable residue, scratches in the finish, and a build up of grime as well as weakened adhesive.

Dimensions: 30" x 9" x 1.5" (76.25 cm x 23 cm x 4 cm)

**Estimate: \$6,000 - 12,000**



52" (132.25 cm)

**502**  
Symbiote SCP-9870 Containment Capsule  
**Venom (2018)**

A Symbiote SCP-9870 containment capsule from Ruben Fleischer's sci-fi action film Venom. Carlton Drake's Life Foundation kept Symbiotes SCP-9870, which called itself Venom, in a containment capsule to use in human experiments.

This lot consists of an acrylic capsule with fiberglass caps screwed on top and bottom, faux brass detailing, yellow hazard symbols painted on the interior, and metal bars affixed on each side. The capsule sits alongside two non-functional canisters with false knobs inside a gray, foam-padded plastic clamshell case with metal locks and rubber handles. Decals featuring the Life Foundation logo, "Mechanized Box 26," and "RC-07" are applied on top. The lot exhibits visible signs of production use and storage, including black Symbiote residue on the capsule's interior, scuffed paint on its caps and handles, water damage to the case, and a loose knob. Dimensions: 52" x 26" x 26" (132.25 cm x 66 cm x 66 cm)

Special shipping required; see notice in the Buyer's Guide.

**Estimate: \$6,000 - 12,000**



46.5" (118.25 cm)

**503**  
 Negan's (Jeffrey Dean Morgan) Lucille Bat  
**The Walking Dead (2010-2022)**

Negan's (Jeffrey Dean Morgan) Lucille bat from AMC's horror series The Walking Dead. In the Season 10 episode, "Here's Negan," Negan dug up his signature weapon - a bat he named "Lucille" for his late wife - and used it to smash the head of a walker, splintering it beyond repair.

This is one of only three bats created by prop master Kelly Farrah for the sequence, which culminates in Negan burning "Lucille" once and for all. Intentionally splintered and distressed by production, this wooden baseball bat is wrapped in metal barbed wire and comes with a white-painted wooden display spattered with blood and signed "Thanks for everything!" in black ink by Farrah. Some of the wiring around the bat has come loose from age, and the wood's texture has grown rough from exposure. Dimensions: 46.5" x 7.5" x 2" (118.25 cm x 19 cm x 5 cm)

**Estimate: \$30,000 - 60,000**



Album / Alamy Stock Photo



**504**  
**King Llane's (Dominic Cooper) Battle Armor with Shield**  
**Warcraft (2016)**

King Llane's (Dominic Cooper) battle armor and shield from Duncan Jones' action-fantasy film *Warcraft*. King Llane wore his armor when he met Durotan (Toby Kebbell) and at the final battle against the Horde at the Great Gate.

This lot consists of a gold- and silver-painted urethane shield featuring a sculpted lion's head with foreign language carved above the head, blue leather arm straps and padding on the backing, and a blue acrylic gem nestled at the top; a silver- and gold-painted urethane armor with: blue cotton and Spandex underpinnings; cotton and leather boots marked "King Llane 10L Hero Dirty"; a cotton and leather belt with gold-color painted urethane and blue acrylic gems marked "Llane Hero Clean"; brown leather gloves; a pair of leather and felt lined vambraces with blue acrylic gems marked "Llane Hero Clean"; a blue cotton and gold-color trim skirt marked "Llane"; a gold-color aluminum and cotton-lined chainmail tunic with an extra collar piece, marked "Llane Stunt"; a leather- and felt-lined cuirass with blue acrylic gems marked "Stunt"; a pair of sculpted lion shoulder covers; a sculpted lion helmet with felt lining and foam padding marked "Hero Dirty"; and a brown synthetic hair wig. This lot exhibits grime and discoloration from age. Dimensions: (shield) 41" x 24" x 6" (104.5 cm x 61 cm x 15.5 cm)

**Estimate: \$40,000 - 80,000**





48.25" (123 cm)

**505**  
 King Llane's (Dominic Cooper)  
 Urethane Sword  
**Warcraft (2016)**

King Llane's (Dominic Cooper) urethane sword from Duncan Jones' action-fantasy film *Warcraft*. King Llane used his sword during the final battle between the humans and the Horde.

This urethane sword is painted silver-color to resemble a metallic shine with carved designs along the blade; a gold-color painted lion sculpted handguard with embossed designs over the blade and with foreign language engravings surrounding a blue acrylic faux sapphire; and a matching gold-color painted sculpted pommel with a smaller blue acrylic faux sapphire; and a navy-painted handle sculpted and textured to resemble leather accents. The sword exhibits imperfect paint patterns on the handguard, scuffs, and chipping paint from production. Dimensions: 48.25" x 9.25" x 3.5" (123 cm x 23.5 cm x 9 cm)

**Estimate: \$4,000 - 8,000**



Guard Detail

**506**  
 King Llane's (Dominic Cooper)  
 Shield  
**Warcraft (2016)**

King Llane's (Dominic Cooper) shield from Duncan Jones' action-fantasy film *Warcraft*. King Llane wielded his royal shield in battle against the Orc Horde.

This fiberglass shield features a gold-color painted sculpted lion's head with foreign language carved above the head, silver-color painted sculpted wings and curved design trim, blue leather arm straps with padding on the backing, and a blue acrylic faux gem nestled at the top of the shield. The shield exhibits scuffing along the trim and chipping paint not notable on the lion's nose from production use, discoloration throughout, and stiffened leather from age. Dimensions: 41" x 24" x 6" (104.5 cm x 61 cm x 15.5 cm)

**Estimate: \$15,000 - 30,000**



Reverse Side

41" (104.5 cm)





**507**  
 Anduin Lothar's (Travis Fimmel)  
 Distressed Troll Battle Armor  
**Warcraft (2016)**

Anduin Lothar's (Travis Fimmel) distressed troll battle armor from Legendary Pictures' fantasy epic Warcraft. Lothar wore his armor in a deleted scene where he fought against King Llane (Dominic Cooper) in their younger days.

This blue and silver-color suit of armor, made primarily of urethane and leather, consists of one cuirass with matching shoulder armor and vambraces; one belted fauld featuring a Stormwind lion; one set of aluminum-link chainmail with polyester-blend underpinnings; one pair of gloves with fastening strips; and one pair of armored boots. All of the elements are marked for "Lothar" with some including the name "Travis." The armor has been distressed by production, including simulated blood on the cuirass. The lot exhibits minimal signs of wear, including scuffing to the urethane and leather.

**Estimate: \$8,000 - 16,000**



**508**  
 Lothar's (Travis Fimmel) Urethane Sword  
**Warcraft (2016)**

Lothar's (Travis Fimmel) urethane sword from Duncan Jones' action-fantasy film Warcraft. Lothar used his sword in battle throughout the film.

This urethane sword is painted silver-color to resemble a metallic shine with carved intricate designs along the base of the blade and a blue sculpted and textured band around the middle of the blade to resemble leather, a silver-color painted ox sculpted handguard with blue acrylic sapphires, and a red painted handle sculpted and textured to resemble spiked leather accents. The sword exhibits imperfect paint patterns on the handguard, scuffs, and chipping paint from production. Dimensions: 46" x 9" x 4" (117 cm x 23 cm x 10.25 cm)

**Estimate: \$3,000 - 6,000**



**509**  
 King Llane's (Dominic Cooper) Flashback Battle Armor  
**Warcraft (2016)**

King Llane's (Dominic Cooper) flashback battle armor from from Legendary Pictures' fantasy epic Warcraft. Llane Wrynn, the King of Stormwind, wore personalized armor in a deleted flashback scene.

The armor consists of two silver- and gold-color padded leather and resin pauldrons; a two-piece silver- and gold-color padded flexible resin cuirass marked "14 Dominic" with metal-buckled leather strap closures; a chain-link tunic with gold-color fabric details, a zipper closure, and brown leather cuffs; padded resin and leather vambraces labeled "Llane Hero F.B." with lion emblems; brown leather gloves with silver- and gold-color resin plates and hook-and-loop closures; a resin and leather belt labeled "Llane Hero Flashback" with a fringed royal blue and gold-color loincloth; and resin armor-plated brown leather boots with rubber soles and "Llane - FB Dominic" and "10" marked on the interior. The armor exhibits wear throughout, with cracked leather, scuffed resin, blood stains and grime intentionally applied to the cuirass by production, and discoloration and rusting to several of the metal components.

**Estimate: \$8,000 - 16,000**



**510**  
 Alliance Royal Guard Distressed Armor With Poleaxe  
**Warcraft (2016)**

A set of Alliance royal guard distressed armor with a poleaxe from Legendary Pictures' fantasy epic Warcraft. Royal guards wore armor and carried poleaxes in the throne room and throughout Stormwind.

This blue and silver-color suit of armor, made primarily of urethane and leather, consists of one helmet with faux hair; one cuirass with matching shoulder armor and vambraces; one belted fauld featuring a Stormwind lion; one brown leather scabbard; one set of aluminum-link chainmail with cotton-blend underpinnings; gloves with fastening strips; and armored boots. The armor has been distressed with production-made denting throughout. Also included is one urethane poleaxe with blue cotton strip embellishments. In addition to the intentional distressing from production, the lot exhibits minimal signs of wear, including scuffing to the urethane and leather. Dimensions: (poleaxe) 95" x 9.5" x 4" (241.5 cm x 24.5 cm x 10.5 cm)

Special shipping required; see notice in the Buyer's Guide.

**Estimate: \$8,000 - 16,000**



**511**  
Alliance Foot Soldier Battle-Damaged  
Armor with Spear and Hand Cannon  
**Warcraft (2016)**

Alliance foot soldier battle-damaged armor with a spear and hand cannon from Legendary Pictures' fantasy epic Warcraft. Alliance foot soldiers wore armor in Stormwind and wielded weapons battling against the Horde.

This blue and silver-color urethane and leather suit of armor consists of one helmet with faux hair; one cuirass with matching shoulder armor and vambraces; one belted fauld featuring a Stormwind lion; aluminum-link chainmail with cotton-blend underpinnings; gloves with fastening strips; and armored boots. The armor has been distressed with production-made denting, including large slashes across the helmet. Also included is one urethane spear with blue cotton strip embellishments and a urethane hand cannon painted to resemble wood and metal. In addition to the intentional distressing from production, the lot exhibits minimal signs of wear, including scuffing to the urethane and leather. Dimensions: (spear) 89" x 6" x 3" (226.5 cm x 15.5 cm x 8 cm)

Special shipping required; see notice in the Buyer's Guide.

**Estimate: \$8,000 - 16,000**



**512**  
Alliance Foot Soldier  
Armor with Sword, Shield, and Hand Cannon  
**Warcraft (2016)**

A set of Alliance foot soldier armor with a sword, shield, and hand cannon from Legendary Pictures' fantasy epic Warcraft. Alliance foot soldiers wore their armor in Stormwind and wielded their weapons in battle against the Horde.

This blue and silver-color suit of armor, made primarily of urethane and leather, consists of one helmet with faux hair; one cuirass with matching shoulder armor and vambraces; one belted fauld featuring a Stormwind lion; one set of aluminum-link chainmail with cotton-blend underpinnings; gloves with fastening strips; and armored boots. Also included is one blue and silver-color urethane Stormwing lion shield with leather straps, one matching urethane sword with a brown leather scabbard, a urethane hand cannon painted to resemble wood and metal, and an orange production tag marked "BG 300 Dwayne Jones." The lot exhibits minimal signs of wear, including scuffing to the urethane and leather. Dimensions: (shield) 33" x 25" x 5" (84 cm x 63.5 cm x 13 cm)

**Estimate: \$8,000 - 16,000**



**513**  
Ray Ferrier's (Tom Cruise) Leather Jacket  
**War Of The Worlds (2005)**

Ray Ferrier's (Tom Cruise) leather jacket from Steven Spielberg's sci-fi horror War of the Worlds. Ferrier wore his jacket throughout the film.

This lot consists of one brown leather jacket made by John David Ridge. It features three exterior pockets with zipper closures, a white and red striped on the arms, and tarnished metal hardware. The interior also features a John David Ridge label marked with a printed "Mr. Tom Cruise, Regular Size" within the internal pocket. Production intentionally distressed this jacket to give it a worn appearance. This lot exhibits some discoloration, mild scuffing, and snagged threads.

**Estimate: \$5,000 - 10,000**



**514**  
Lawrence Talbot's (Benicio Del Toro) Sword Cane  
**The Wolfman (2010)**

Lawrence Talbot's (Benicio Del Toro) sword cane from Joe Johnston's period horror film The Wolfman. Lawrence wielded his sword cane against his father, Sir John (Anthony Hopkins), as he was attacked.

This lot consists of one sword cane. Featuring a resin wolf head painted silver-color as the handle, this sword cane comes with a wooden sheath with a resin ferrule painted a silver-color. The handle lifts to reveal the aluminum blade and the collar of the cane rotates to move and lock into place the cross guard. This lot exhibits cracking and splitting in the sheath; notable chipped paint; and loose components. Dimensions: 39.5" x 6" x 1.5" (100 cm x 15.25 cm x 4 cm)

**Estimate: \$5,000 - 10,000**

**515**  
**Sir John Talbot (Anthony Hopkins) Wolfman Bust**  
**The Wolfman (2010)**

A Sir John Talbot (Anthony Hopkins) Wolfman bust from Joe Johnston's period horror film *The Wolfman*. Sir John fought his son Lawrence (Benicio del Toro) in his werewolf form as a fire rampaged Talbot Hall.

This bust consists of a fully painted raw latex casting that resembles the snarling face of a werewolf, a foam cowl neck, and plastic mannequin torso with foam shoulder supports. Original paintwork was left from production and additional paintwork was applied. Covered in hand-laid synthetic fur added post-production, the mask features hand-glued eyelashes and blue resin eyes. This lot exhibits some shedding and sparseness of synthetic fur on the torso. Dimensions: 14" x 21.5" x 27" (35.5 cm x 54.75 cm x 68.5 cm)

**Estimate: \$8,000 - 12,000**



**516**  
**Amazonian Warrior Bracers**  
**Wonder Woman (2017)**

Amazonian warrior bracers from Patty Jenkins' superhero film *Wonder Woman*. Amazon warriors of Themyscira wore bracers as part of their ensembles.

This lot consists of two bracelets with two straps. Made of heat-treated foam, leather, and metal hardware, these bracelets were painted with a metallic gold and silver-color paint. On the interior, there are white tape labels hand-marked "AAB 113," and "Nikol." They also feature writing directly on the bracelets for "L" and "R" in silver-color marker, as well as the number "113," which has faded along with a barely legible "Nikol." Production intentionally distressed these bracelets to appear aged and battle-worn. This lot exhibits some cracking in the finish, scuffing on the interior and edges, and worn leather.

**Estimate: \$3,000 - 6,000**



**517**  
**Wonder Woman's (Gal Gadot)**  
**Sword of Athena, Harness, and Lasso of Truth**  
**Justice League (2017)**

Wonder Woman's (Gal Gadot) Sword of Athena, harness, and Lasso of Truth from Zack Snyder's superhero film *Justice League*. Wonder Woman wielded her signature lasso and sword, first seen in *Batman v Superman: Dawn of Justice*, when the Justice League fought Steppenwolf (Ciaran Hinds) and his minions.

This lot consists of a polyurethane sword painted to resemble steel with a faux gold handle engraved with an eagle symbol, a faux gold pommel, and a textured blue grip; a leather harness and sheath with self-fastening closures, decorative straight stitching, metal hardware, and rubber accents painted to appear metallic; and a woven rope lasso with molded faux gold tips. This lot has gone under sympathetic repair. The sword is intentionally distressed by production to appear battle-used and the harness exhibits chipped paint and scratched leather. Dimensions: 36" x 6" x 3" (91.5 cm x 15.25 cm x 7.75 cm)

**Estimate: \$20,000 - 40,000**





**518**  
Wolverine's (Hugh Jackman) Claws  
**X2: X-Men United (2003)**

Wolverine's (Hugh Jackman) claws from Bryan Singer's superhero sequel X2: X-Men United. Amnesiac mutant Wolverine searched for clues to his past and used his retractable claws to defend students at Xavier's School for Gifted Youngsters from the forces of anti-mutant extremist William Stryker (Brian Cox) throughout the film.

Originating from a source close to production, this lot consists of a pair of claws with three urethane blades each. Both claws are attached to metal grips by curved rods which are meant to fit between the fingers of the wearer. The backs of the claws extend over the wearer's knuckles to give the appearance they come from the hand. This lot exhibits pitting and knicks in the claws. Dimensions: 10" x 6" x 2.5" (25.5 cm x 15.25 cm x 6.25 cm)

**Estimate: \$20,000 - 40,000**

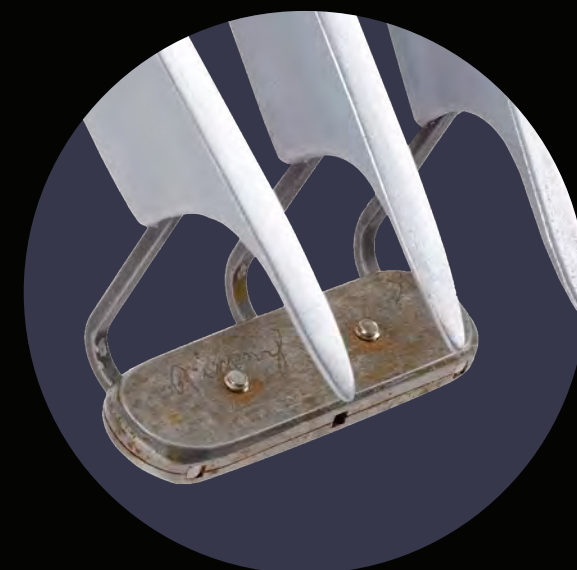



36" (91.5 cm)

**519**  
**Framed Hand-Painted Greg Hildebrandt Dead Man Logan Cover Artwork**  
**Marvel Comics**

Framed cover artwork hand-painted by Greg Hildebrandt for Marvel Comics' Dead Man Logan. Hildebrandt painted the piece as a variant cover for the first of 12 issues in the limited series published by Marvel Comics in 2018.

This artwork depicting Logan taking a knee in the desert while a vision of his younger self appears over him in the sky is rendered in acrylic paint on canvas and signed by Hildebrandt in the lower left corner. It comes mounted behind glass in a custom-made frame. Dimensions (framed): 24" x 36" x 1" (61 cm x 91.5 cm x 2.75 cm)

Sold without copyright; see notice in the Buyer's Guide.

Stored off-site; see off-site storage notice in the Buyer's Guide.

**Estimate: \$6,000 - 12,000**



**520**  
**Wolverine's (Hugh Jackman) Stunt Claws**  
**X2: X-Men United (2003)**

Wolverine's (Hugh Jackman) stunt claws from Bryan Singer's superhero sequel X2: X-Men United. Amnesiac mutant Wolverine used his retractable adamantium claws throughout the film to defend students at Xavier's School for Gifted Youngsters from anti-mutant extremist William Stryker (Brian Cox).

This lot consists of a pair of stunt claws, each with three rubber blades painted silver and affixed via curved rods to metal grips designed to fit between the wearer's knuckles. The left claw is engraved "1" with "L" etched in its base, while the right claw is engraved "1" with "R" etched. According to the film's stunt coordinator Gary Jensen, these claws were created after he was injured by a pair made of dense urethane. Also included are a Letter of Authenticity on production letterhead from Jensen stapled to a packet of production-printed storyboards. The claws exhibit brown and black stains and some bending from production use. Dimensions: (each) 11" x 3" x 2" (28 cm x 7.75 cm x 5 cm)

**Estimate: \$6,000 - 12,000**

**521**  
**Fox Mulder (David Duchovny) and Dana Scully (Gillian Anderson) FBI ID Badges**  
**The X-Files (1993-2018)**

Fox Mulder (David Duchovny) and Dana Scully (Gillian Anderson) FBI ID Badges from the 11th season of the television sci-fi series The X-Files. FBI special agents Mulder and Scully carried their badges during paranormal investigations throughout the season.

This lot consists of two plastic ID cards with metal clips. Printed directly onto the card, these IDs feature the "FBI" header, a stamp, "Special Agent" header, signature, a color photograph of the badge's agent, and certified fine print. Both badges also feature a holographic overlay with a graphic of the planet over a band repeating "Authentic" in various languages. This lot exhibits scratches in the finish and minor imperfections from production. Dimensions: (each) 2.25" x 3.25" x 0.25" (5.5 cm x 8.25 cm x 0.75 cm)

**Estimate: \$5,000 - 10,000**

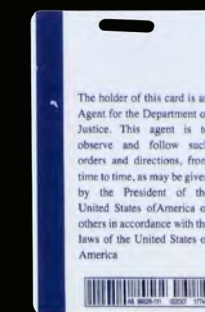

Back of Badge

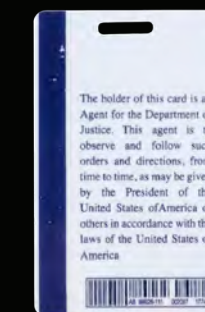

Back of Badge

**522**  
Xena's (Lucy Lawless)  
Shattered Chakram  
**Xena: Warrior Princess (1995-2001)**

Xena's (Lucy Lawless) shattered chakram from the fantasy action series Xena: Warrior Princess. In the Season 2 episode "The Xena Scrolls," Dr. Janice Covington (Renee O'Connor) and Melinda "Mel" Pappas (Lucy Lawless) found Xena's signature weapon broken in a Macedonian tomb.

This two-piece metal chakram is painted silver-color and gold-color, etched with geometric patterns, and inset with rare New Zealand paua stones. Each piece's tip features jagged edges made to appear shattered by production. The chakram exhibits paint scuffing throughout and has been dulled by production. Dimensions: 9.75" x 1.25" x 0.5" (25 cm x 3 cm x 1.5 cm)

**Estimate: \$3,000 - 6,000**

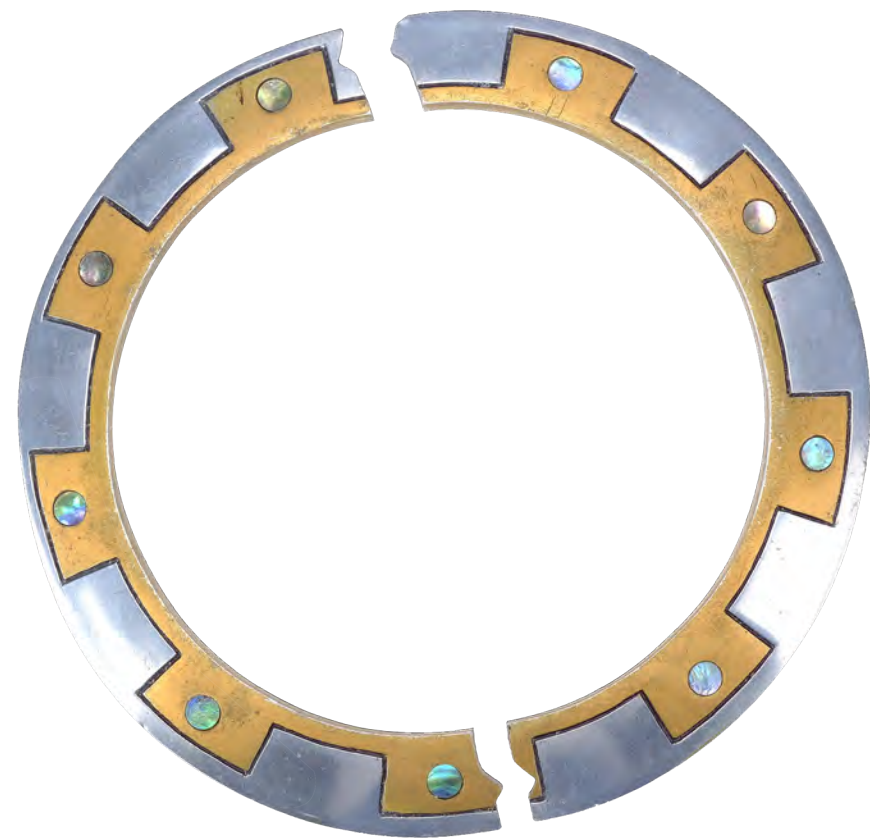

**523**  
Zorro's (Antonio Banderas)  
Lightweight Costume  
**The Legend Of Zorro (2005)**

Zorro's (Antonio Banderas) lightweight costume from Martin Campbell's swashbuckling sequel The Legend of Zorro. The masked vigilante Zorro (Antonio Banderas) wore his signature costume throughout the film as he fought to stop the Knights of Aragon.

This all-black, lightweight version of Zorro's costume consists of an unfinished felt wide brim hat marked "B"; a lightweight puffy fabric blend long-sleeve shirt with a front drawstring, pointed collar, and cape slits on the shoulders; a lightweight cape with cord trim, elastic ties, and leather embroidered in an arabesque pattern along the sides and back; and velvet stunt pants with metal buttons marked "SONY W" on the back hem and "Dino Pads" for stuntman Dino Dos Santos on the left leg cuff. Also included are three Columbia Pictures Certificates of Authenticity. The costume exhibits loose threads from missing buttons on the cape, sewn holes, and holes in the trousers.

**Estimate: \$8,000 - 16,000**

# Propstore

# Wanted

## Props, Costumes and Artifacts from Movies and Television

Sell Your Memorabilia with Propstore to Maximize Your Return

**SHORT CIRCUIT (1986)**  
Full-Size Light-Up Johnny 5 Robot

sold for \$330,625

incl. bp

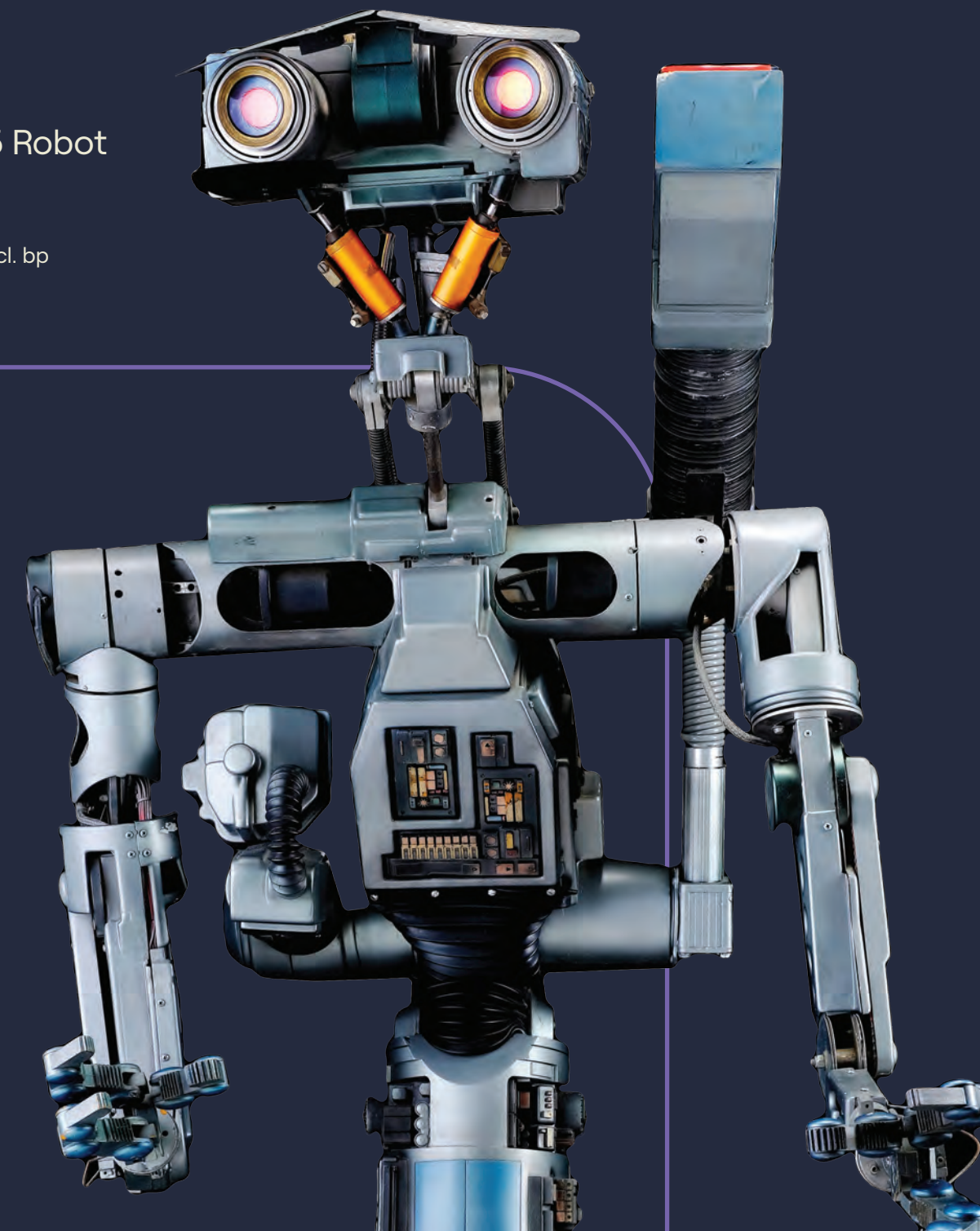

Propstore CA Bond # 72B58GU4116

[propstore.com/sell](http://propstore.com/sell)



# Day 2

Lots 524 - 1014.  
June 29, 2023



**524**  
Cruella De Vil's (Glenn Close)  
Pheasant Feather Costume  
**102 Dalmatians (2000)**

Cruella De Vil's (Glenn Close) pheasant feather costume from Kevin Lima's adventure-comedy film 102 Dalmatians. De Vil wore her pheasant feather dress as she discussed her dalmatian pelt coat with Jean-Piere Le Pelt (Gerard Depardieu). This lot consists of a tiger print shimmer tulle long train dress; matching print gloves with black acrylic nails; matching print heels marked "Glenn Close"; and one production tag labeled "Cruella #13." This dress features a black and gold-color ribbon tulle petticoat, a pheasant and black feather trim, and a black feather collar. The feathers are secured to the dress with metal beads and wiring. Included are three Certifications of Authenticity from The Walt Disney Company Disney Auctions. This lot exhibits loose black feathers and fragile pheasant feathers.

**Estimate: \$2,500 - 5,000**



**526**  
11-Photo Panorama of Stanley Kubrick's "War Room"  
**2001: A Space Odyssey (1968)**

An 11-photo panorama of Stanley Kubrick's "War Room" from the production of his sci-fi epic 2001: A Space Odyssey. Kubrick filled his production office at MGM-British Studios in Borehamwood, Hertfordshire with documents detailing the film's highly complex blend of live-action footage and visual effects, earning it the nickname "War Room." These 11 images offering a 360-degree perspective of the "War Room" were captured by a production photographer, then gifted by MGM's publicity department to a film programmer in 1971. The rare full set is printed in black-and-white on glossy photo stock. They exhibit bending throughout. Dimensions: 8.75" x 9.5" (22.25 cm x 24.25 cm)

**Estimate: \$800 - 1,600**

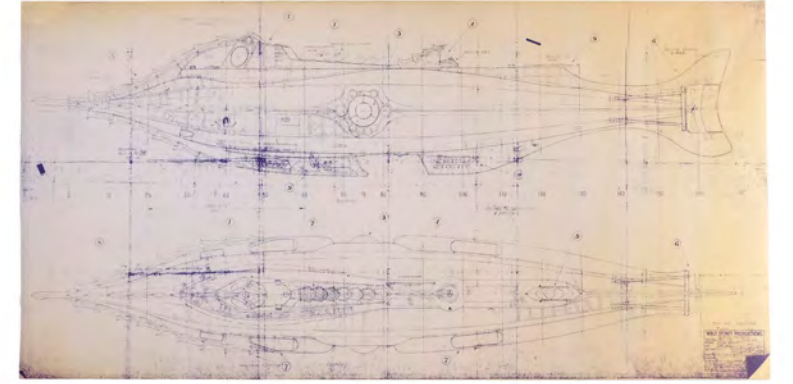

**525**  
Printed Nautilus Blueprint  
**20,000 Leagues Under The Sea (1954)**

A printed Nautilus blueprint from the production of Richard Fleischer's sci-fi classic 20,000 Leagues Under the Sea. Ned Land (Kirk Douglas) joined the crew of Captain Nemo's (James Mason) submersible, Nautilus, on its way to Vulcania. The submarine was rendered with a combination of model miniatures and built interiors. Photocopied by production for distribution amongst the art department, this blueprint features top and side views for one of the Nautilus miniatures. It is labeled "Walt Disney Productions, Burbank California," "Set No. 15," and "Ext. Nautilus"; numbered "2087"; dated "10-26-53"; and attributed to art directors John Meehan and Harper Goff with annotations throughout. The blueprint exhibits creasing from being rolled for storage. Dimensions: 36" x 71" (91.5 cm x 180.5 cm)

**Estimate: \$1,500 - 3,000**

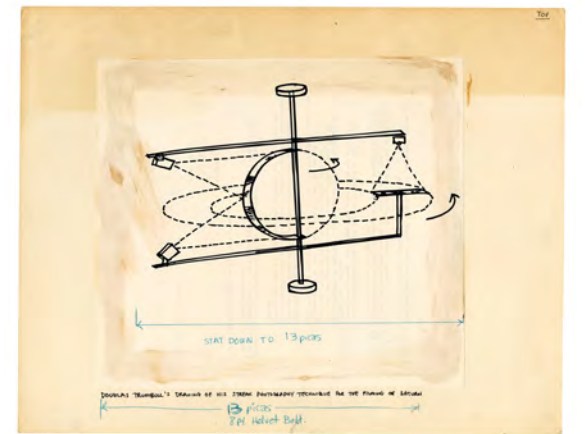

**527**  
Hand-Drawn Douglas Trumbull Slit Scan Effect Sketch  
**2001: A Space Odyssey (1968)**

A hand-drawn Douglas Trumbull sketch of the slit scan effect from Stanley Kubrick's sci-fi epic 2001: A Space Odyssey. Special photographic effects supervisor Trumbull utilized an innovative variation on slit scanning, filmed Kubrick-curated kaleidoscopic artworks through a "slit" in the "mask," for the iconic Star Gate sequence. Trumbull created this sketch of the slit scan process during the promotion for Silent Running. It is rendered in black marker on paper mounted to backing board and hand-labeled "Douglas Trumbull's drawing of his streak photography technique for the filming of Saturn." It exhibits margin stains. Dimensions: 14" x 11" (35.75 cm x 28 cm) Sold without copyright; see notice in the Buyers Guide.

**Estimate: \$600 - 1,200**



\*Certain films and shows have Lots offered on more than one day of the Auction; see index on page 706 for a complete listing of available Lots by film or show title



**528**  
Set of Promotional Ephemera  
**2001: A Space Odyssey (1968)**

Ephemera from the promotion of Stanley Kubrick's sci-fi epic 2001: A Space Odyssey. MGM capitalized on the film's reputation as a psychedelic experience for young viewers by advertising a 1971 screening at The Ziegfeld Theatre as "The Ultimate Trip." MGM's publicity department gifted this set to a film programmer who helped put the screening together. It consists of 57 black-and-white publicity stills; two psychedelically-patterned metal pins labeled "2001: The Ultimate Trip"; a spooled 35mm trailer for the film; and a black-and-white invitation to the Ziegfeld screening. The invitation and photos exhibit creasing. Dimensions: 8" x 10" x 13" (20.5 cm x 25.5 cm x 33 cm)

**Estimate: \$600 - 1,200**



**530**  
Hand-Painted Bill Mather Night Desert Matte Painting  
**A Far Off Place (1993)**

A hand-painted Bill Mather night desert matte painting from Edward Zwick's comedy-drama A Far Off Place. Nonnie Parker (Reese Witherspoon), Harry Winslow (Ethan Randall), and Xhabbo (Sarel Bok) camped out in the desert after they successfully found water and food. This lot consists of one oversize matte painting on a framed glass panel. It features a hand-painted image of a desert at night with a sky full of stars, and the very center unpainted. It also features a hand-marked "SC-121" on the upper right corner. The back has layers of production-applied tape. This lot exhibits chipped paint, scratches, and lifted tape. Dimensions: 49.5" x 61" x 1" (125.75 cm x 155 cm x 2.5 cm) Special shipping required; see notice in the Buyer's Guide. Sold without copyright; see copyright notice in the Buyer's Guide.

**Estimate: \$1,500 - 3,000**

**529**  
Reggie Hammond's  
(Eddie Murphy) Costume  
**48 Hrs. (1982)**

Reggie Hammond's (Eddie Murphy) costume from Walter Hill's crime-action film 48 Hrs. Hammond wore his costume during his parole service as he worked alongside Officer Jack Cates (Nick Nolte) to track down a killer. This lot consists of a gray-looking suit featuring a black, white, and red plaid patterned wool jacket labeled "E Murphy G" with matching trousers labeled "Eddie Murphy"; as well as a gray silk pocket square. Included with this lot are two phone memos addressed to Murphy dated March 28 in the trousers pocket. This lot exhibits wrinkles and folds to the memos. Dimensions: (memos) 5" x 2.75" (12.75 cm x 7 cm)

**Estimate: \$1,500 - 3,000**



**531**  
Ace Ventura's (Jim Carrey)  
Red Striped Trousers  
**Ace Ventura:  
Pet Detective (1994)**

Ace Ventura's (Jim Carrey) red striped trousers from Tom Shadyac's comedy film Ace Ventura: Pet Detective. Ventura wore his red striped trousers in several scenes throughout the film, including the finale. This lot consists of a pair of red cotton trousers with black vertical stripes, two pockets, a button fly, a black pull-tie front, belt loops on the back, and an ABC Costume Shop/Four Star Costumes Inc. tag sewn inside. The trousers exhibit staining throughout from production use.

**Estimate: \$2,000 - 4,000**



**532**  
Aeon Flux's  
(Charlize Theron) Costume  
**Aeon Flux (2005)**

Aeon Flux's (Charlize Theron) costume from Karyn Kusama's sci-fi action film Aeon Flux. Aeon Flux wore her costume throughout the film as she fought to free the people of Bregna. The year before portraying her, Theron won an Academy Award® for Best Actress for Patty Jenkins' drama Monster. This futuristic black stretch nylon one-piece jumpsuit features distinctive corset-like lace detailing across the midsection, elasticated strapping across the shoulders, and a pair of built-in leather upper shoes with rubber soles. It features a lace-up closure at the rear and gray paneling on the crotch and sides of the legs. The costume exhibits grime and discoloration from production wear.

**Estimate: \$2,500 - 5,000**



**533**  
Pluto Nash's (Eddie Murphy) Helmet  
**The Adventures Of Pluto Nash (2002)**

Pluto Nash's (Eddie Murphy) helmet from Ron Underwood's sci-fi-comedy film The Adventures of Pluto Nash. Nash wore his helmet when he arrived at a prospecting dome on the Far Side of the Moon. This orange-painted urethane helmet features a clear acrylic visor and metal base to connect the helmet to a space suit. It opens by the dials on the sides, turned simultaneously, to activate the helmet's hydraulics and is black felt-lined. Included is a connector piece with an orange-painted urethane base, rubber tube, and a mesh covered cable. This lot exhibits minor scuffing and chipping paint. Contains mechanical and electrical components; see notice in the Buyer's Guide.

**Estimate: \$1,000 - 2,000**



**534**  
Dr. Charles Henry Moffet's  
(David Hemmings) Flight Suit by  
Jean-Pierre Dorleac  
**Airwolf (1984-1987)**

Dr. Charles Henry Moffet's (David Hemmings) flight suit by Jean-Pierre Dorelac from Donald P. Bellisario's military drama series Airwolf. The deranged Dr. Moffet, inventor of the prototype supersonic stealth helicopter, absconded with the craft in the series' pilot. Designed by Emmy®- and Academy Award®-winning costume designer Jean-Pierre Dorleac, this custom-made medium gray cotton twill jumpsuit features full-length zip closure, a hook-and-loop closure stand collar and pockets, banded epaulets, black quilted nylon contrasting stripes on the outer sides and inner legs, embroidered "AIRWOLF" patches, a two-tone embroidered "MOFFET" nametape, and embroidered three-toned "MED" and arrow emblem next to a red embroidered arrow above the knee. It features the following hand-markings: a "1 DAVID HEMMINGS" on the inside of the gray cotton belt, and a faded hand-marked "D. HEMMINGS" neck tag. Included are brown-green cotton duck lace-up desert boots with black rubber toe cap, each hand-marked "D. HEMMINGS" on the interior. The lot exhibits color fading, discoloration and loose threads from use and conveyance.

**Estimate: \$3,000 - 6,000**



**535**  
Mad Hatter Maquette Crew Gift with Crew-Autographed Thank You Card  
**Alice In Wonderland (2010)**

A Mad Hatter maquette crew gift with crew-autographed Thank You card from Tim Burton's fantasy-adventure film Alice In Wonderland. Crews were often gifted mementos after a film's release. This lot consists of a hand-painted resin maquette mounted to a bronze-color resin base and a "Thank you For a great show" card in an acrylic display. The card is autographed by Tim Burton, Peter M. Tobyansen, Richard D. Zanuck, Tom C. Peitzman, Katterli Frauenfelder, and Derek Frey. This lot exhibits chipping paint and grime. Dimensions: (maquette) 6.5" x 3.5" x 3" (16.5 cm x 9 cm x 7.75 cm); (display) 5.5" x 3" x 8.5" (14 cm x 7.75 cm x 21.75 cm)

**Estimate: \$1,500 - 3,000**

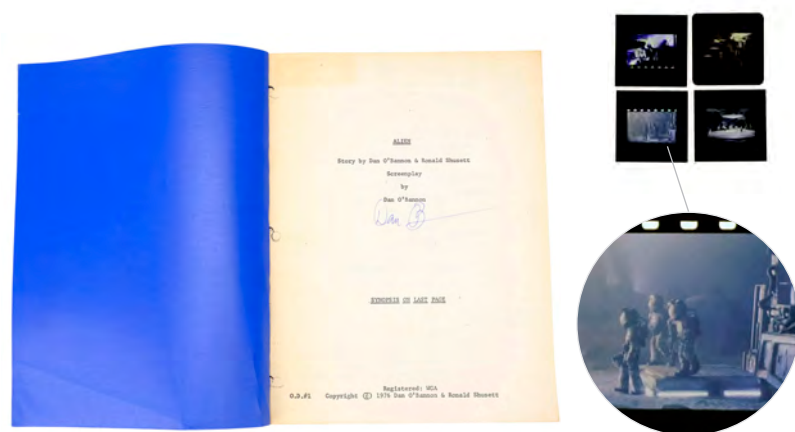

**537**  
Dan O'Bannon-Autographed Script with Synopsis and Slides  
**Alien (1979)**

A Dan O'Bannon-autographed script with a synopsis and slides from Ridley Scott's sci-fi-horror film Alien. This 132-page script is bound in a blue plastic cover with a sticker labeled "ALIEN" and features a 1976 copyright on the inside cover along with an autograph by writer Dan O'Bannon in blue ink. Included is a synopsis of the film; a space light year diagram; four matted color slides in a clear plastic sleeve marked "AC 1989," "AC1602," and "AC 217." This lot exhibits a fold crease and wrinkle on the front cover from storage. Dimensions: 8.5" x 11" x 0.75" (21.75 cm x 28 cm x 2 cm)

**Estimate: \$1,000 - 2,000**



**536**  
Hand-Drawn John Mollo Concept Sketches, Notes, and Production Photos  
**Alien (1979)**

Hand-drawn John Mollo concept sketches, notes, and production photos from Ridley Scott's sci-fi-horror film Alien. Hand-drawn by costume designer John Mollo, this lot consists of four sketches and doodles of a cap, sneakers, belts, pouches, a jacket, and a Nostromo crew shirt with a patch on the sleeve. Included in the lot are two photocopy pages of lists of actors' measurements, costume pieces needed, one page of spacesuit armor etching examples with illegible notes along the edge, and four black-and-white production photos of the cast and Kane's (John Hurt) spacesuit. This lot exhibits folds from production and major discoloration from age. Dimensions: 8.5" x 13" (21.75 cm x 33 cm) Sold without copyright; see notice in the Buyers Guide.

**Estimate: \$2,500 - 5,000**



**538**  
Collection of Production Ephemera and Promotional LP  
**Alien (1979)**

Production ephemera and a promotional LP from Ridley Scott's sci-fi horror film Alien. Vinyl records like this were used to promote films on radio shows. This lot is composed of a box lid from Rank Film Laboratories; a 36-page unit list; a shooting schedule; an Alien logo; an advance screening ticket; and a promotional LP featuring cast and crew interviews. Included is a letter from the director of advertising and publicity department with notes. This collection exhibits discoloration, paper creasing and folding, minor tearing on the paper, lifted labels, and notable marks. Dimensions: 15" x 15" x 1" (39.5 cm x 39.5 cm x 2.75 cm)

**Estimate: \$1,200 - 2,400**

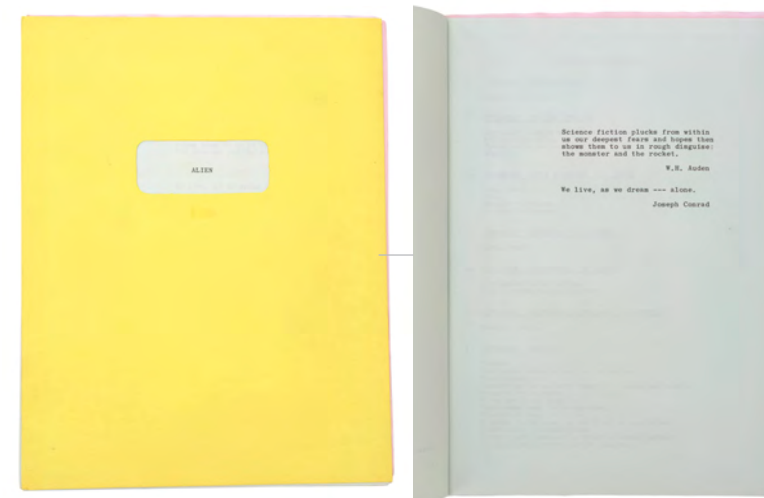

**539**  
Charles Lippincott Collection: Revised Final Draft Screenplay  
**Alien (1979)**

A revised final draft screenplay from Ridley Scott's sci-fi-horror film Alien. Written by Walter Hill and David Giler, this 124-page revised final draft screenplay is dated June 1978. This lot comes from the collection of the film's advertising and publicity consultant Charles "Charley" Lippincott. It is printed on various colored paper indicating the different revision dates and features edits made with the colored paper covering various parts of the text and hand-written red X's. This screenplay has a yellow cardstock cover and is in a production manila folder marked "Alien Script." This lot exhibits discoloration throughout from the colored paper edits. Dimensions: 9" x 11.75" x 0.75" (23 cm x 30 cm x 2 cm)

**Estimate: \$800 - 1,600**



**540**  
Dave Jones Collection: Necronomicon with Printed H.R. Giger Autograph and Additional Giger Books  
**Alien (1979)**

A copy of Swiss surrealist H.R. Giger's Necronomicon with a printed Giger autograph, as well as additional copies of his art books. Giger received an Academy Award® for his work creating the iconic xenomorphs from Ridley Scott's Alien. In 2013, he was inducted into the Science Fiction and Fantasy Hall of Fame. This lot comes from the collection of veteran model maker Dave Jones. It consists of a Necronomicon with retellings by Abdul Alhazred and a printed Giger autograph on the interior cover; a hardcover Alien design book documenting the creation of the xenomorphs; an HR Giger ARH+ book published June 1981; and a 1995 Giger-themed calendar. The ARH+ book exhibits loose pages and the Necronomicon's cover is loose. Dimensions: (largest) 12" x 16.5" x 0.5" (30.5 cm x 42 cm x 1.5 cm)

**Estimate: \$1,500 - 3,000**

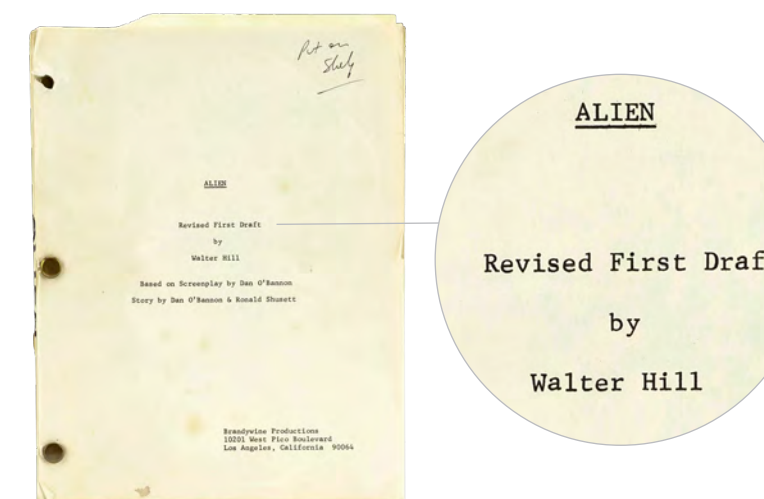

**541**  
Production Script  
**Alien (1979)**

A production script from Ridley Scott's action-sci-fi film Alien. This 139-page script is a revised first draft by Walter Hill based on the screenplay by Dan O'Bannon and Ronald Shusett. The script features a handwritten annotation in ink on the front cover and "ALIEN" in black marker along the spine. Included with this lot is a Letter of Authenticity signed by Joel Silver as it comes from his private collection. This lot exhibits stains, discoloration, and a loose end page. Dimensions: 8.5" x 11" x 0.75" (21.75 cm x 28 cm x 2 cm)

**Estimate: \$1,000 - 2,000**



**542**  
**Cast-Autographed Replica M577**  
**APC Tank Model-Miniature Display**  
**Aliens (1986)**

A cast-autographed replica M577 APC tank model-miniature display from James Cameron's sci-fi horror film sequel Aliens. Ripley (Sigourney Weaver), Hicks (Michael Biehn), and the other Marines arrived at terraforming colony Hadley's Hope in two Armored Personnel Carriers (APCs). This lot consists of one polystone resin tank with a Sulaco-themed display base hand-painted in shades of gray. It features the autographs of Sigourney Weaver, Carrie Henn, Michael Biehn, Paul Reiser, Lance Henriksen, Bill Paxton, William Hope, Jenette Goldstein, Mark Rolston, Ricco Ross, Daniel Kash, and Cynthia Scott. Also included are 12 authentication cards in two envelopes, and the model's box. This lot exhibits some scuffing and notable discoloration. Dimensions: 24.5" x 12.25" x 12.25" (62.25 cm x 31.25 cm x 31.25 cm)

**Estimate: \$6,000 - 12,000**

**543**  
**Production-Made Xenomorph**  
**Queen Puppet Cast Components**  
**Aliens (1986)**

A production-made xenomorph Queen puppet cast components from James Cameron's sci-fi horror film sequel Aliens. After Ripley (Sigourney Weaver) destroyed the eggs in the hive, the Queen revealed herself and fought Ripley while she was in an exosuit cargo-loader. This lot consists of one headcrown, one torso, and one leg. Made of brown and black polyfoam, these castings feature the unique biomechanical look HR Giger created, with detailed ribbing and sinew. This lot exhibits tears in the foam, raw edges, and notable paint marks. Dimensions: (each) 22" x 12" x 6" (56 cm x 30.5 cm x 15.25 cm)

**Estimate: \$1,000 - 2,000**

**544**  
**Limited-Edition 30th Anniversary**  
**Reebok Alien Stomper Sneakers**  
**Aliens (1986)**

A pair of limited-edition high-top alien stomper sneakers produced by Reebok to commemorate the 30th anniversary of James Cameron's sci-fi sequel Aliens. Reebok created Ripley's (Sigourney Weaver) original high-top sneakers for the film and in 2016 released a limited run of 426 replica pairs. This lot consists of a pair of calf-high white, red, and gray sneakers. They feature three self-fastening straps and a bright red tongue. The boots are a unisex U.S. 10/U.K. 9/EUR 43. They are in unworn condition with all original tags, and come in a holographic "Weyland-Yutani Corp" shoebox. This lot exhibits snagged seam threads, some minor creasing on the self-fastening straps and wear on the box. Dimensions: (each) 12" x 9" x 11" (30 cm x 23 cm x 28 cm)

**Estimate: \$2,000 - 4,000**



**545**  
**Dave Jones Collection:**  
**Production-Made Castings of**  
**Xenomorph Go-Motion Puppet**  
**Alien3 (1992)**

Production-made castings of a xenomorph go-motion puppet from David Fincher's sci-fi horror sequel Alien 3. After emerging from a dog, a sleeker xenomorph attacked the inhabitants of Fiorina 161. Inspired by H.R. Giger's original design, these brown and gray rubber puppet components cast from the rod puppet used to show the xenomorph's movement come from the collection of veteran model maker Dave Jones. Also included are 35 hand-annotated production photographs of the puppet, 74 pages of various production paperwork, and a vacuum-formed pull. This lot exhibits unrefined edges, fold and crease marks, and mild discoloration. Dimensions: (largest) 22" x 19" x 12" (56 cm x 48.25 cm x 3.5)

**Estimate: \$1,200 - 2,400**

**546**  
**1/4-Scale Xenomorph**  
**Rod Puppet Head**  
**Alien3 (1992)**

A 1/4-scale xenomorph rod puppet head from David Fincher's sci-fi horror sequel Alien 3. After gestating inside a dog, a sleeker, smaller, quadrupedal xenomorph attacked the inhabitants of a penal colony on the planet Fiorina 161. The xenomorph was brought to life with a combination of VFX and the use of a rod puppet. This cast resin xenomorph head with a visible tongue inside is painted brown and black with silver-color fangs and a notch on the dome's underside for mounting. It exhibits sticky residue and some scratching from production. Dimensions: 10.5" x 2.5" x 3.75" (26.75 cm x 6.5 cm x 9.5 cm)

**Estimate: \$4,000 - 8,000**



**547**  
**Static Xenomorph Egg**  
**Alien Resurrection (1997)**

A static xenomorph egg from Jean-Pierre Jeunet's sci-fi sequel Alien: Resurrection. Facehugger aliens hatched out of xenomorph eggs and latched on to a host to lay an egg which became a chestburster. This large egg is made of silicone around a fiberglass core which is supported by an inner metal frame. This piece was created with two large vertical slits down the left and right sides for the puppeteers to place their arms through to puppeteer the facehuggers as they were "hatched" from the egg. This lot exhibits a slimy surface texture. Dimensions: 15" x 15" x 24" (38.25 cm x 38.25 cm x 61 cm)

**Estimate: \$3,000 - 6,000**





**548**  
**United Systems Military Sidearm**  
**Alien Resurrection (1997)**

A United Systems Military sidearm from Jean-Pierre Jeunet's sci-fi sequel Alien Resurrection. This was the standard sidearm for USM soldiers, also used by the mercenary Johner (Ron Perlman) as he attempted to rescue his comrades Christie (Gary Dourdan) and Vriess (Dominique Pinon). This lot consists of one static pistol made of resin with a metal barrel. Painted blue, silver-color and black, it has been intentionally distressed with silver paint to appear scratched. This lot exhibits some chipped paint and pitting from the curing process. Dimensions: 10.5" x 6" x 1.5" (25 cm x 16 cm x 4 cm) Restricted ownership; see replica firearm notice in the Buyer's Guide.

**Estimate: \$1,000 - 2,000**



**549**  
**Newborn Legs**  
**Alien Resurrection (1997)**

A pair of Newborn legs from Jean-Pierre Jeunet's sci-fi horror sequel Alien: Resurrection. The result of cloning experiments conducted by the United Systems Military, the Newborn viewed Ripley 8 (Sigourney Weaver) as its mother. Designed and fabricated by the special effects group Amalgamated Dynamics, Inc. (ADI), this lot consists of a pair of foam and latex legs, which feature small wrinkles, spots, and defined muscles throughout. The feet feature a small metal post protruding from the sides. Hand-painted gray, white, and pink with a glossy finish, these legs were mounted on a black metal display stand. This lot exhibits some foam and latex fragility. Dimensions: 36" x 25" x 52" (91.5 cm x 63.5 cm x 132 cm)

**Estimate: \$1,500 - 3,000**



**550**  
**Predator Helmet and Xenomorph**  
**Face Executive Gift Set**  
**AVP: Alien Vs. Predator (2004)**

A Predator helmet and xenomorph face executive gift set from the production of Paul W.S. Anderson's sci-fi adventure AVP: Alien vs. Predator. Production gifted this set to executives involved with the film. This lot consists of a fiberglass Predator mask painted chrome-color with mesh-patterned clear plastic details affixed to the eye holes on the interior and a fiberglass xenomorph face with a resin interior shell and separate jaw component. Both feature interior metal triangular hooks that allow for display. They exhibit minimal wear, including scuffing to the back where they would hang against a wall. Dimensions: 20" x 15" x 14" (51 cm x 38 cm x 35.5 cm)

**Estimate: \$1,000 - 2,000**



**551**  
**Xenomorph Costume**  
**Alien War (Attraction, 1992)**

A Xenomorph costume from the live experience Alien War. A "total reality" experience, Alien War placed attendees right in the middle of an intense conflict between Xenomorphs and Colonial Marines. This Xenomorph costume is made primarily of foam latex with yellow foam filling, painted black and brown, and consists of one foam head with silver-color teeth and additional foam padding inside for the wearer, one zip-up black lycra bodysuit with foam latex xenomorph skin attached on the arms, legs, and torso, hands with silver-color nails, one spine section with protruding foam dorsal tubes and part of a shoulder crest, another section of a shoulder crest, two large sections of foam latex skin unattached from the bodysuit, one foam tail with rope loops, and wool slippers with foam latex applied over them to create feet. The foam latex exhibits extensive hardening, cracking, and crumbling throughout, with pieces deteriorating and falling away and the separated lower jaw of the head formerly held on with zip ties and staples.

**Estimate: \$3,500 - 7,000**



**552**  
**Takeshi Kovacs' Unicorn Backpack**  
**Altered Carbon (2018-2020)**

A Takeshi Kovacs' unicorn backpack from the action sci-fi series Altered Carbon. Kovacs purchased a drug-filled backpack from a dealer after being revived 250 years in the future. This pink unicorn backpack features a pink urethane hard shell and canvas exterior with a rainbow and unicorn vinyl covered in hand-drawn doodles, a foam padded backing and shoulder straps, and two mesh water bottle pockets. This backpack exhibits intentional distressing throughout, glue residue along the top, and a tear in the interior lining. Dimensions: 11" x 6.5" x 15" (28 cm x 16.5 cm x 38.25 cm)

**Estimate: \$800 - 1,600**



**553**  
**Eddie Jessup's (William Hurt) SFX Altered Makeup**  
**Appliance with Cinefantastique Magazines**  
**Altered States (1980)**

Eddie Jessup's (William Hurt) SFX altered makeup appliance from Ken Russell's sci-fi horror film Altered States. Psychophysicist Jessup devolved into an ape-like primitive after self-experimenting with deprivation tanks. Jessup's transformation was brought to life by SFX makeup artist Dick Smith, who designed this foam latex face appliance. The appliance is hand-painted greenish-yellow with pink lips, inset with a jaundiced urethane right eye, and mounted to a wooden base with a styrofoam bust. Also included are copies of Cinefantastique Volume 11 No. 1 and 2 featuring cover stories on Smith's makeup for the film. The appliance exhibits significant cracking and stiffening from production wear and age, and should be handled with caution. Dimensions (magazines, each): 9" x 11" x 0.25" (23 cm x 28 cm x 0.25 cm)

**Estimate: \$1,500 - 3,000**





**554**  
Tools and Weapons  
**Amistad (1997)**

Tools and weapons from Steven Spielberg's historical drama Amistad. Cinque (Djimon Hounsou) led an uprising on the Spanish slave ship La Amistad. This lot consists of a pistol; a brass hilt knife with a wooden handle; a leather knife sheath; a brass telescope; a metal chain segment; and an iron stake. The lot exhibits rust, scuffing, scratches, cracking, paint wear, and paint chipping. Dimensions: (gun) 20" x 4" x 2" (50.75 cm x 10.25 cm x 5.25 cm); (stake): 8" x 1" x 1" (20.25 cm x 2.5 cm x 2.5 cm) Ownership may be restricted in some countries; see replica firearm notice in Buyer's Guide.

**Estimate: \$600 - 1,200**



**556**  
Middle Eye's (Gerardo Taracena) Dagger  
**Apocalypse (2006)**

Middle Eye's (Gerardo Taracena) dagger from Mel Gibson's action adventure Apocalypse. Middle Eye slit the throat of Jaguar Paw's (Rudy Youngblood) father, Flint Sky (Morris Birdyellowhead). Simon Atherton, an armorer who worked with Gibson on Braveheart, was hired to research and provide reconstructions of Mayan weapons to maintain the accuracy of the film. This lot consists of one production-distressed resin dagger with a metal blade featuring detailing and dark engraved patterns on the hilt to resemble obsidian and wood. This lot exhibits mild discoloration and pitting. Dimensions: 11" x 2" x 2" (28 cm x 5 cm x 5 cm) Blade was dulled after production to sell as a collectible.

**Estimate: \$1,000 - 2,000**



**555**  
Coach Tony D'Amato (Al Pacino) Jacket  
**Any Given Sunday (1999)**

A Coach Tony D'Amato (Al Pacino) jacket from Oliver Stone's sports drama film Any Given Sunday. The coaching staff of the Miami Sharks had jackets featuring the team's logo, D'Amato was ultimately not seen wearing his. This lot consists of a gray nylon-blend zip-up collared jacket with two front pockets, button cuffs, a Dominic Gherardi custom tailoring label printed with the name "Al Pacino" and dated "January 1999," and white thread embroidery on the chest of a Miami Sharks logo and the name "Coach D'Amato." The embroidery exhibits a few loose threads.

**Estimate: \$1,500 - 3,000**



**557**  
Ceremonial Bone Knife  
**Apocalypse (2006)**

A hollow bone knife from Mel Gibson's action adventure Apocalypse. Zero Wolf (Raoul Trujillo) took the ceremonial knife offered to him and cut his palm with it after bringing the captives to the pyramid's apex. This lot consists of one hollow SFX knife. This resin knife features a sawtooth blade and decorative engraved designs lined and painted in blue-black ink. It also features a plastic reservoir for SFX blood inside the knife handle. This lot exhibits notable blood makeup residue, cracking, and pitting. Dimensions: 13" x 1.5" x 1.5" (33 cm x 4 cm x 4 cm)

**Estimate: \$1,000 - 2,000**

**558**  
Mayan Photo  
Double Costume  
**Apocalypto (2006)**

Mayan photo double costume from Mel Gibson's action adventure Apocalypto. The Mayan city was a hub that had many different indigenous people from all walks of life living there. This costume consists of a neck piece, a stole, a wrap, and shoes. Composed of a poly-blend, the neck piece, stole, and wrap feature colorful Mezo-American designs and braided fringes. The shoes feature rubber soles and tan leather uppers with adjustable straps. Also included is a production tag hand-marked with "K Son [sic] Photo Dbl." Production intentionally distressed this costume to appear worn and dirty. This costume exhibits discoloration, as well as snagged and loose threads.

**Estimate: \$700 - 1,400**



**559**  
Zero Wolf's (Raoul Trujillo) SFX Obsidian-Bladed Knife  
**Apocalypse (2006)**

Zero Wolf's (Raoul Trujillo) SFX obsidian-bladed knife from Mel Gibson's action adventure Apocalypto. Zero Wolf stabbed a raider after he showed cowardice for jumping off a waterfall. This lot consists of a single SFX blade. Cast in foam and painted to replicate the look of an obsidian blade with a wooden handle, the handle features engraved patterns across the surface. Two carved heads and a plume of artificial black hair make up the pommel. Production intentionally removed the end of the blade to expose the inner foam. This lot exhibits residual stickiness and SFX blood. Dimensions: 12" x 3" x 1.5" (30.5 cm x 7.75 cm x 4 cm)

**Estimate: \$800 - 1,600**

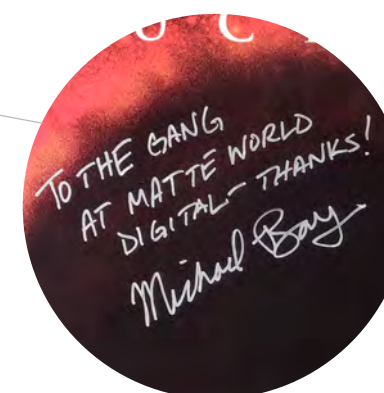

**560**  
Framed Michael Bay-Autographed One-Sheet  
**Armageddon (1998)**

A framed one-sheet autographed by Michael Bay from the promotion of Bay's sci-fi adventure Armageddon. Matte World Digital produced digital matte paintings and other VFX for the film. This original full-color one-sheet depicting an asteroid heading towards Earth was gifted by Bay to Matte World after production. It is signed "To the gang at Matte World Digital - thanks!" in silver-color marker by Bay and comes mounted behind glass in a brown wooden frame. The poster exhibits some creasing and the glass is grimy from exposure. Dimensions: 28" x 41" x 2" (71.25 cm x 104.25 cm x 5 cm)

**Estimate: \$500 - 1,000**



**561**  
Production-Made Remote Detonation Code  
**Armageddon (1998)**

A production-made remote detonation code from Michael Bay's sci-fi adventure Armageddon. After he was ordered to remotely detonate the nuke by the President, General Kimsey (Keith David) broke open the plastic container to retrieve the code. Printed on red cardstock, this production-made remote detonation code features "DBDEGGTZ" in black ink. This code was folded into thirds and displays two prominent production-made creases. This lot exhibits some fading of the letters across the creases, and gaps in the letters from printing. Dimensions: 6.5" x 3.5" (16.5 cm x 9 cm)

**Estimate: \$600 - 1,200**



69"  
(175.25  
cm)

**562**  
Full-Size Deadite Soldier Puppet  $\Delta$   
**Army Of Darkness (1992)**

A full-size deadite soldier puppet from Sam Raimi's comedy horror sequel Army of Darkness. In the climactic finale, Ash J. Williams (Bruce Campbell) led the forces of the living against Evil Ash's (Campbell) army of deadites. This large, static puppet is constructed from latex, foam, and resin, molded around a metal puppeteering rod, dressed with mesh garments, painted in earth tones to simulate rotted flesh and bone, and secured with a resin helmet, shoulder strap, and mixed media shield painted silver-color to appear metallic. It is intentionally distressed throughout by production with grime applied throughout and holes in the shield and face, and also exhibits cracking and torn foam from age. Dimensions: 69" x 14" x 9" (175.25 cm x 35.75 cm x 23 cm) Special shipping required; see notice in the Buyer's Guide.

**Estimate: \$2,500 - 5,000**



**563**  
Thea Queen's (Willa Holland)  
Speedy Bow  
**Arrow (2012-2020)**

Thea Queen's (Willa Holland) Speedy bow from the DC superhero series Arrow. Oliver Queen's (Stephen Amell) half-sister Thea wielded her signature bow as her superhero alter-ego Speedy throughout the series. This three-piece wooden and metallic bow is hand-painted in Speedy's signature maroon and black colorway. Each section screws together at its tip, but they are not equipped for a string, as the strings in the series were created with digital effects. The bow exhibits paint flaking, chipping, and exposed metal from production use. Dimensions: 51.5" x 2.5" x 5" (131 cm x 6.5 cm x 12.75 cm)

**Estimate: \$800 - 1,600**



**564**  
Ash Williams' (Bruce Campbell)  
Severed Hand  
**Ash Vs Evil Dead (2015-2018)**

Ash Williams' (Bruce Campbell) severed hand from horror comedy television series Ash vs Evil Dead. Amanda Fisher (Jill Marie Jones) cut off the Other Ash's hand after he attacked her and chopped it into pieces. This lot consists of one silicone severed hand appliance. It features sculpted fingernails and flesh-like details painted to appear like a rotten and pustule-covered hand. It has gone under sympathetic restoration to restore it to its uncut condition, and maintains the initial cut marks. This lot exhibits residual and flaking SFX make up. Dimensions: 4.5" x 9" x 2" (11.5 cm x 23 cm x 5.25 cm)

**Estimate: \$2,000 - 4,000**



115"  
(292.25  
cm)

**565**  
Austin Powers' (Mike Myers)  
Cryogenic Chamber  
**Austin Powers: International Man  
Of Mystery (1997)/Austin Powers:  
The Spy Who Shagged Me (1999)**

Austin Powers' (Mike Myers) cryogenic chamber from Jay Roach's Austin Powers films, International Man of Mystery and The Spy Who Shagged Me. Powers was awakened from cryogenic stasis to battle Dr. Evil (Myers) in the first film, then had his mojo stolen by Fat Bastard (Myers) while still frozen in the sequel. This large chamber is constructed from gray fiberglass, wood, plastic, and metal. It features openings for inserting a forklift; two front and back windows; two translucent inserts shaped like Powers' body; a cut-out "Austin Powers" name plate on top; and a translucent, paper-covered platform. The chamber exhibits cracking and paint chipping throughout the fiberglass with plastic elements cracking and breaking away around Powers' hands, part of the "U" missing from the nameplate, a section missing from the rear panel, and lighting effects which are no longer functional. Dimensions: 50" x 58" x 115" (127 cm x 147.5 cm x 292.25 cm) This lot, due to its size, weight, and/or nature will require specialist shipping service with additional cost. Bidders are strongly advised to contact Propstore for a shipping quote prior to bidding. Special shipping required; see notice in the Buyer's Guide. Contains electronic components; see notice in the Buyer's Guide.

**Estimate: \$3,000 - 6,000**



**566**  
Automan's (Chuck Wagner)  
Auto Suit with Breakaway  
AutoElectric Uniform  
**Automan (1983-1984)**

Automan's (Chuck Wagner) auto suit with breakaway AutoElectric uniform from the superhero series Automan. Automan donned his signature jumpsuit throughout early episodes of Season 1, as well as an electrician's uniform in the episode "Zippers," a white shirt in the episode "The Great Pretender," and a tan shirt in the episode "Unreasonable Facsimile."

These costumes were designed by Jean-Pierre Dorleac. They consist of a blue jumpsuit with boot stirrups, a rear zipper, and patches of special retroreflective sheeting applied throughout to appear luminescent; a pair of leather Fabrizio Los Angeles high-heeled boots with reflective patches; a tan polyester and cotton work shirt affixed with red and white electricity-themed graphics and concealed fastening strip enclosures for tearing quickly off the wearer; matching breakaway pants with fastening strip closures; a white cotton Bosweel After Six pleated long-sleeve dress shirt; and a tan H Bar C California Ranchwear permanent press western shirt with dark brown trim and a faux pearl snap closure. Silver-color synthetic material is sewn to each shirt collar. The jumpsuit is an early variant distinguished from Automan's primary suit by its ribbed sides.

Also included is a black and white promotional print featuring two photos from the series with a caption and 20th Century Fox copyright information. The lot exhibits wear from use and age, including staining, cracks in the adhered graphics, and rips and worn finish in some of the reflective patches.

**Estimate: \$2,000 - 4,000**

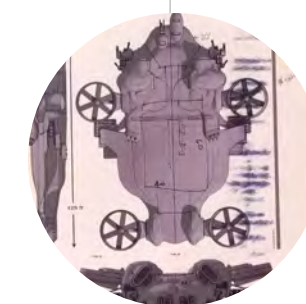

**567**  
Production Binder with Hand-  
Drawn Artwork, Production  
Paperwork, and Designs  
**Avatar (2009)**

A production binder with hand-drawn artwork, production paperwork, and designs from James Cameron's epic sci-fi film Avatar. Consisting of 59-pages, this black three-ring binder features a call sheet, concept art, sketches, scene breakdowns and set descriptions. It also features hand-marked annotations and sketches in graphite and black ink throughout. Also included is a tan envelope hand-marked with "AVATAR" and "PROJECT 880." This collection exhibits some water damage, discoloration, tearing on the edges, and creases. Dimensions: 10" x 12" x 2" (25.5 cm x 31.75 cm x 4 cm) Sold without copyright; please see notice in the Buyers Guide.

**Estimate: \$1,000 - 2,000**

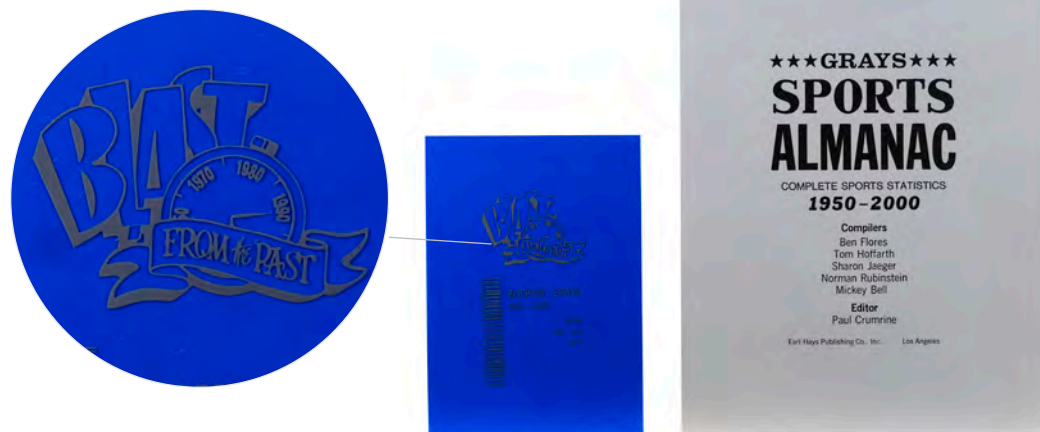

**568**  
 Production-Made Blast from the Past Receipt with Grays Sports Almanac Flyleaf  
**Back To The Future Part II (1989)**

A production-made Blast from the Past receipt with a Grays Sports Almanac flyleaf from the production of Robert Zemeckis' sci-fi sequel Back to the Future Part II. In 2015, Marty McFly (Michael J. Fox) purchased a vintage sports almanac from antique store Blast from the Past. This lot consists of two pieces made by Earl Hays Press: a black-and-white paper flyleaf labeled "Grays Sports Almanac" with a list of credits on front, including for real-world production printer Earl Hays Publishing Co., and a transparent blue plastic "Blast from the Past" receipt labeled "Almanac, Grays" and printed with a barcode and serial number in white. The plastic exhibits warping from handling. Dimensions: (largest) 8.5" x 11" (21.75 cm x 28 cm)

**Estimate: \$1,500 - 3,000**

**569**  
 Pair of Hoverboard Wire Bundles  
**Back To The Future Part II (1989)**

A pair of hoverboard wire bundles from the production of Robert Zemeckis' sci-fi sequel Back to the Future Part II. The illusion of hoverboards in flight was achieved through a number of different special effects techniques, including wire flying rigs that held the boards and riders in the air. This lot consists of two bundles of metal wires, bound with white plastic zip ties, each with a nail on one end and a D-ring-like loop on the other. The metal exhibits some discoloration from age and the nails are bent slightly. Dimensions: (each, bound) 6" x 6" x 1" (15.25 cm x 15.25 cm x 2.75 cm)

**Estimate: \$1,000 - 2,000**

**570**  
 Marty McFly's (Michael J. Fox) Termination Fax  
**Back To The Future Part II (1989)**

Marty McFly's (Michael J. Fox) termination fax from Robert Zemeckis' sci-fi adventure sequel Back to the Future Part II. McFly was terminated by Mr. Fujitsu (Jim Ishida) over the phone for making an illegal deal with Needles (Flea), causing termination faxes to appear throughout McFly's house. This yellow paper fax was originally gifted by co-writer/producer Bob Gale to unit publicist Michael Klasterin. It is labeled "YOU'RE FIRED" in black block text beneath a burgundy "CUSCO" logo. Also included is a Letter of Authenticity from Gale on Universal Pictures letterhead. The fax was hole-punched following production and exhibits light tearing. Dimensions: 8.5" x 11" (21.75 cm x 28 cm)

**Estimate: \$3,000 - 6,000**



**571**  
 Pair of Production-Made Biffco Currency Notes  
**Back To The Future Part II (1989)**

Two production-made Biffco currency notes from Robert Zemeckis' sci-fi adventure sequel Back to the Future Part II. After he stole the sports almanac, Biff Tannen (Thomas F. Wilson) used his knowledge of future sports events to build a gambling empire, which gave him a license to print his own money. This lot consists of two single-sided cream-color paper bills, in "1" and "10" dollar denominations, each bearing Tannen's face on the center with green and gray lettering. They exhibit minimal edge wear. Dimensions (each): 6.25" x 3" (16 cm x 7.75 cm)

**Estimate: \$1,000 - 2,000**



**572**  
 McFly Family Dehydrated Pizza Hut Wrapper  
**Back To The Future Part II (1989)**

A dehydrated Pizza Hut wrapper from Robert Zemeckis' sci-fi adventure sequel Back to the Future Part II. Lorraine McFly (Lea Thompson) brought a bag of rehydratable pizzas to a family dinner at her son Marty's (Michael J. Fox) house. This silver, red, and black foil "Half Pepperoni Half Green Pepper 15 inch" pizza wrapper features a printed Pizza Hut logo and instructions for how to prepare the meal. The wrapper exhibits visible scratching on both sides from production. Dimensions: 5.5" x 5.5" (14 cm x 14 cm)

**Estimate: \$1,200 - 2,400**



**573**  
 Biffco \$50 Currency Note  
**Back To The Future Part II (1989)**

A Biffco \$50 currency note from Robert Zemeckis' sci-fi adventure sequel Back to the Future Part II. After he stole the sports almanac, Biff Tannen (Thomas F. Wilson) used his knowledge of future sports events to build a gambling empire, which gave him a license to print his own money. This lot consists of a single-sided cream-color paper \$50 bill with green and dark gray lettering and bearing Tannen's face on the center. Small text printed on the note states that it is not valid and was made for motion picture use only. Dimensions: 6.25" x 2.75" (16 cm x 7 cm)

**Estimate: \$400 - 800**



**574**  
Michael J. Fox and Cast-  
Autographed Replica Hoverboard  
**Back To The Future Part II (1989)**

A Michael J. Fox and cast-autographed replica hoverboard from Robert Zemeckis' adventure sci-fi Back to the Future: Part II. Marty McFly (Fox) attempted to escape from Griff (Thomas F. Wilson) and his gang on a hoverboard, and pretended to be his son Marty Jr. This cast-autographed, hot pink plastic licensed replica features autographs in blue marker by Lea Thompson, Michael J. Fox, Thomas F. Wilson, and Christopher Lloyd, featuring two authenticity stickers below Lloyd's autograph. It exhibits minor decal creases and scuffing, with accompanying fully-readable Beckett Authentication Services sticker exhibiting a torn-away edge. The accompanying COA exhibits corner creasing and edgewear. Dimensions: 28" x 8.25" x 3 (71.25 cm x 21 cm x 7.75 cm)

**Estimate: \$2,000 - 4,000**

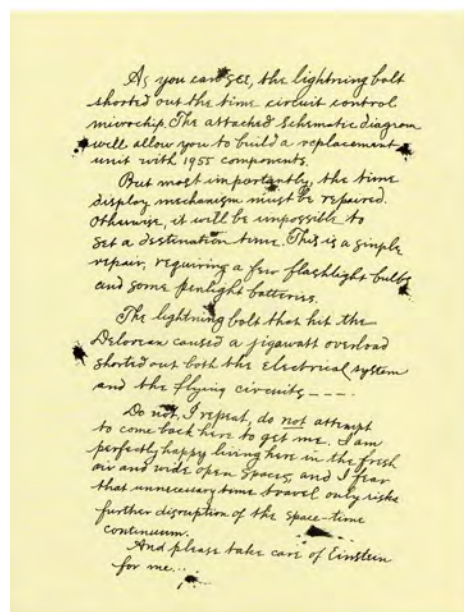

**575**  
Page from Doc's (Christopher  
Lloyd) 1885 Repair Letter to Marty  
(Michael J. Fox)  
**Back To The Future Part III (1990)**

A page from Doc's (Christopher Lloyd) 1885 repair letter to Marty (Michael J. Fox) from Robert Zemeckis' sci-fi adventure sequel Back to the Future Part III. While in 1955, McFly received a letter sent by Doc from 1885 informing him that he was alive and how to fix the DeLorean. This paper letter features cursive text printed in black ink. Although the text varies slightly from what is spoken and seen in the final cut, it contains several of the same phrases and elements McFly reads out loud. The letter exhibits several production-made ink blotches and minor discoloration from age. Dimensions: 11" x 8.5" (28 cm x 21.5 cm)

**Estimate: \$3,000 - 6,000**



**576**  
Hill Valley Telegraph  
**Back To The Future Part III (1990)**

A Hill Valley Telegraph newspaper from Robert Zemeckis' sci-fi adventure sequel Back to the Future Part III. After traveling back to 1885, Marty McFly (Michael J. Fox) encountered Buford "Mad Dog" Tannen (Thomas F. Wilson) in a saloon where a man was reading the newspaper behind them. This Hill Valley Telegraph newspaper is dated "September 2, 1885" and consists of 12 pages of black-and-white newsprint stock, with repeating content on the interior pages. The lot exhibits discoloration and curled edges. Dimensions: 16" x 12.25" (40.5 cm x 31 cm)

**Estimate: \$1,000 - 2,000**



**577**  
"B" Clapperboard and Bound Script  
**Basic Instinct (1992)**

A "B" clapperboard and bound script from the production of Paul Verhoeven's neo-noir thriller Basic Instinct. This brass brad-bound, 114-page script is dated March 6, 1991 and features a glossy beige cover. The clapperboard features an acrylic white slate with a striped wooden clapper dated "8/8/91." It is engraved in blue with the film's title, date, and the names of director Paul Verhoeven and cameraperson Jan DeBont. Also engraved are "Roll," "Scene," and "Take." This lot exhibits minor discoloration and edgewear on the script, and chipped paint on the clapper. Dimensions: 12" x 12" x 3" (30.5 cm x 30.5 cm x 7.75 cm)

**Estimate: \$1,500 - 3,000**



**579**  
Storyboard Copies and Production Paperwork  
**Batman (1989)**

Storyboard copies and production paperwork from Tim Burton's action-adventure film Batman. Production created copies of storyboards and documents to use during filming. This lot consists of a five-page packet of the direction of Joker's parade with printed annotations and nine pages of storyboard copies with printed and handwritten annotations. This lot exhibits staining on some of the pages, a torn page from production use, and fading ink on one of the storyboards. Dimensions: 8.5" x 11" (21.75 cm x 28 cm) Sold without copyright; see copyright notice in the Buyer's Guide.

**Estimate: \$600 - 1,200**



**578**  
Production Paperwork  
**Batman (1989)**

Production paperwork from Tim Burton's action-adventure film Batman. This lot consists of a 45-page Main Unit One Line Schedule dated October 6, 1988; four call sheets marked number 2, 4, 15, and 46 with dates ranging from October 1988 to December 1988; a partial 54-page pink script with a revision date of October 10, 1988; and a Batman logo cast and crew screening United Kingdom invitation dated August 6. This lot exhibits various fold creases from storage and age, a tear on the script, and light stains on the call sheets. Dimensions: 8.5" x 11" x 0.25" (21.75 cm x 28 cm x 0.75 cm)

**Estimate: \$1,000 - 2,000**



**580**  
Tucker Cobblepot's (Paul  
Reubens) Costume  
**Batman Returns (1992)**

Tucker Cobblepot's (Paul Reubens) costume from Tim Burton's action-fantasy film Batman Returns. Cobblepot wore his costume as he awaited his son's birth. This lot consists of a white poly-cotton button-down shirt (M 34-35) marked "MEL WB"; a black Warner Bros. Pictures vest (size 42) marked "Butler Chas Coleman Sam Ulson"; a monochromatic ascot with a faux pearl gem; a black jacket; black and gray stripe Warner Bros. Pictures trousers marked "T.B.S. W.B. DOUBLES"; white elastic suspenders marked "WB"; and a production tag labeled "For Visual Effects Silhouette For Penguin's Father." This lot exhibits discoloration and disintegrating material on the jacket's lining.

**Estimate: \$1,000 - 2,000**



**581**  
Red Triangle Gang Clown Overcoat  
**Batman Returns (1992)**

A Red Triangle Gang clown overcoat from Tim Burton's action film *Batman Returns*. Fat Clown (Travis McKenna) and Thin Clown (Doug Jones) wore their unique overcoats as they and their fellow members of the Red Triangle Gang attacked Gotham Square during the Christmas tree lighting ceremony. This variant of that style overcoat was ultimately unseen in the final cut. This lot consists of a hand-painted canvas oversized coat with a dark gray fur lining and wood and white nylon toggle buttons. The painted design on this coat is similar to Picasso's 2-dimensional abstract style. This lot exhibits holes in the canvas, detaching lining on the bottom, sticking material, and overall poor cleanliness.

**Estimate: \$1,200 - 2,400**



**582**  
Production-Made Batman  
(Michael Keaton) Cowl Cast  
Display and Mold  
**Batman Returns (1992)**

A production-made Batman (Michael Keaton) cowl cast display and mold from Tim Burton's superhero sequel *Batman Returns*. Production commissioned this bust for aid in the visualization of the cowl's design. The mold was created in the workshop during the time of production, but not in an official production capacity. Designed by costume designer Bob Ringwood and created by Vin Burnham and co-sculptor Alli Eynon, this plaster cast bust was made to visualize the look and fit of Batman's mask. It features Batman's head and shoulders, covered by the sculpted brow, pointy ears, and scalloped edges of the mask. It comes displayed on a wooden stand. Also included is a two-piece plaster cowl mold with a silicone detail insert. The casting exhibits clay remnants, notable paint marks, chipping along the edge, and pitting; while the mold exhibits discoloration, grime, and tearing to the edges of the silicone. Dimensions (largest): 25" x 26" x 15" (63.5 cm x 66.25 cm x 38.25 cm)

**Estimate: \$4,000 - 8,000**



**583**  
Production-Made Batman  
(Michael Keaton) Torso Armor  
**Batman Returns (1992)**

Production-made Batman (Michael Keaton) torso armor from Tim Burton's superhero sequel *Batman Returns*. Batman wore his iconic armored batsuit while fighting crime in Gotham City. This lot consists of a black foam rubber torso piece that covers the abdomen, chest, and partially the arms. The style of the abdominal armor is specific to *Batman Returns*, and while the chest has an oval-shape emblem cavity, the lack of mounting holes in the cavity indicates that this piece was likely never used in a fully assembled costume. The fragile foam rubber exhibits tearing and deterioration throughout, but has undergone preservation work, including being mounted to a fiberglass casting of Keaton's chest for stability.

**Estimate: \$1,500 - 3,000**



**584**  
Batmobile Batdisc  
**Batman Returns (1992)**

A Batmobile batdisc from Tim Burton's superhero sequel *Batman Returns*. Batman (Michael Keaton) fired discs out of the side of the Batmobile to knock two of the Penguin's henchmen off their motorcycles. Made from heavy plastic, this circular batdisc features Batman's iconic logo with a hole in the center for mounting to an FX rig and a gray ring around the outside edge of the top of the disc. It exhibits some wear from use and age, including scuffing throughout and some light staining on the outer ring. Dimensions: 8" x 8" x 1" (20.5 cm x 20.5 cm x 2.75 cm)

**Estimate: \$1,200 - 2,400**



**585**  
Hand-Drawn Batman Cape Illustration  
with Production Storyboards  
**Batman Returns (1992)**

A hand-drawn Batman cape illustration with production storyboards from the production of Tim Burton's superhero sequel *Batman Returns*. This lot consists of a graphite hand-drawn Batman cape on tracing paper taped to white paper, as well as nine printed storyboards and production paperwork with both printed and handwritten annotations. This lot exhibits minor discoloration, fading ink, correction fluid stains, and pin holes from production. Dimensions: 17" x 11" (43.25 cm x 28 cm) Sold without copyright; see notice in the Buyer's Guide.

**Estimate: \$600 - 1,200**



**586**  
Hollywood Wax Museum Catwoman (Michelle Pfeiffer) Display  
**Batman Returns (1992)**

A Catwoman (Michelle Pfeiffer) display from the promotion of Tim Burton's superhero sequel *Batman Returns*. After Max Shreck (Christopher Walken) attempted to murder her, Selina Kyle was reborn as Catwoman. This display was originally created by Hollywood Wax Museum curator Ken Horn for exhibition before entering private collections. It consists of a hand-painted fiberglass mannequin dressed with a latex replica cowl stitched throughout with Catwoman's iconic white thread; a matching padded cotton blend zip-up replica bodysuit; matching leatherette replica gloves; and matching lace-up stiletto replica boots. Sympathetic restoration was undertaken to seal the latex and repair the cowl's nose. However, the costume still exhibits significant signs of exposure and age, flaked and cracking latex, peeling leatherette, and white staining to the boots. Dimensions: 55" x 22" x 31" (140 cm x 56 cm x 79 cm)

**Estimate: \$4,000 - 8,000**



**587**  
Set of Two-Face's Stunt Makeup Appliances  
**Batman Forever (1995)**

Two-Face's stunt makeup appliances from Joel Schumacher's superhero sequel *Batman Forever*. Two-Face (Tommy Lee Jones) aligned with Edward Nygma (Jim Carrey) to get their revenge on Batman (Val Kilmer). This set of stunt makeup appliances for Two-Face's acid-burned head was created by special makeup designer Rick Baker's Cinovation Studios but ultimately unused onscreen. It consists of 18 foam latex peach-color appliances painted and hand-labeled to simulate various stages of burning as well as a clear plastic bust for stability. The set exhibits tape residue and some edge tearing to the latex from production and age. Dimensions: (largest) 14" x 9" x 6" (36 cm x 23 cm x 15 cm)

**Estimate: \$800 - 1,600**



**588**  
Light-Up Police Car Model Miniature Display  
**Batman Forever (1995)/Batman & Robin (1997)**

A display of a light-up police car model miniature from Joel Schumacher's superhero films *Batman Forever* and *Batman & Robin*. In both films, Gotham City police officers drove antique police cruisers in keeping with the series' uniquely timeless style. This lot consists of a plastic and metal model Studebaker painted black and blue with white and silver-color details, decals including a Gotham City Police shield crest, and red and blue lights on the top. It is displayed inside an acrylic case with a printed background of a cityscape and wires leading to the police lights from a switch on the back of the display powered by a 9V battery. The acrylic exhibits scratching. Dimensions: 9.5" x 5" x 4.25" (24.25 cm x 12.75 cm x 11 cm) Contains electronics; see electronics notice in the Buyer's Guide.

**Estimate: \$1,500 - 3,000**



**589**  
Limited-Edition ICONS Robin's Throwing Bird Replica Display  
**Batman & Robin (1997)**

A limited-edition ICONS replica of Robin's throwing bird from Joel Schumacher's superhero sequel *Batman & Robin*. Robin (Chris O'Donnell) kept his signature "Birdarang" on his utility belt. This limited-edition metal ICONS/Warner Bros. replica with extended wings is handmade from the original throwing bird in spun cast zinc with nickel plating. It is hand-painted in ruby and silver-color and housed in a custom lucite display case with plexibox above an ICONS plaque engraved with edition number "010." The plaque exhibits some wear and the Birdarang exhibits minor flaking paint and scuff marks from handling. Dimensions: 8.5" x 14" x 4" (21.75 cm x 35.75 cm x 10.25 cm)

**Estimate: \$1,000 - 2,000**



**590**  
Limited Edition Hand-Painted "Almost Got 'Im" Animation Cel with Background  
**Batman: The Animated Series (1992-1995)**

A limited edition hand-painted "Almost Got 'Im" animation cel with background from the series *Batman: The Animated Series*. In the Season 1 episode, "Almost Got 'Im," iconic Gotham villains gathered in a nightclub and shared moments they almost got Batman. This limited edition hand-painted acetate cel features the Gotham villains playing poker. It is taped to a foam board over a printed color background and marked "457/500" with a gray embossed Warner Brothers logo. Included is a Certification of Authenticity from Warner Brothers and care instructions. Dimensions: 18" x 11.5" x 0.5" (45.75 cm x 29.25 cm x 1.5 cm) Sold without copyright; see notice in the Buyer's Guide.

**Estimate: \$800 - 1,600**



**591**  
Lorne Peterson Collection: Production-Made Colonial Warrior Blaster and Holster  
**Battlestar Galactica (1978)**

Colonial warrior blaster components from the sci-fi TV movie *Battlestar Galactica*. Captain Apollo (Richard Hatch) blasted the Ovion Alien's elevator controls with his blaster. Made for production but ultimately unfinished, this resin blaster comes from the collection of miniature and optical effects unit model builder Lorne Peterson. It consists of two half-shells, a clear plastic barrel painted black, and a plastic holster. The blaster shell is finished in dark blue and the inside is hand-marked with "200 AMS" and "171 AMS." This lot exhibits pitting in the resin, discoloration, and notable adhesive residue. Dimensions: 10.75" x 7" x 1.25" (27.5 cm x 18 cm x 3.25 cm)

**Estimate: \$1,200 - 2,400**

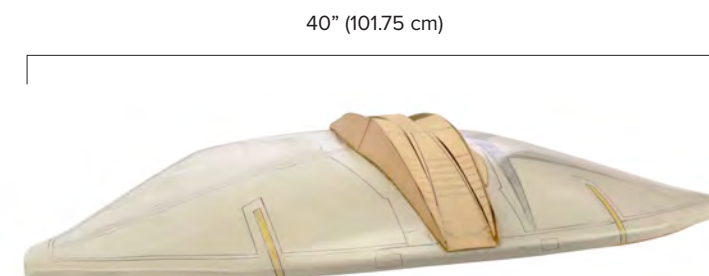

**593**  
Dave Jones Collection: Advanced Cylon A-B Raider Study Model and Wings with Hand-Drawn Sketch  
**Battlestar Galactica 1980 (1980)**

An advanced Cylon A-B Raider study model and wings with a hand-drawn sketch from Glen A. Larson's sci-fi series *Battlestar Galactica* 1980. In the Season 1 episode "The Night the Cylons Landed, Part 1," Cylon craft crashed on Earth. This lot comes from the collection of veteran model maker Dave Jones. It consists of a white plastic and paper study model with hand-drawn detailing; unfinished wings; and a paper sketch of model views rendered and annotated in pen and graphite. The components exhibit scuffs, scratches, edge wear, and creasing throughout. Dimensions: (largest) 40" x 14" x 3" (101.75 cm x 35.5 cm x 7.75 cm) Sold without copyright; see copyright notice in the Buyer's Guide.

**Estimate: \$1,000 - 2,000**



**592**  
Dave Jones Collection: Set of Colonial Viper Model Miniature Casting Components  
**Battlestar Galactica (1978)**

Colonial Viper model miniature casting components from the production of Glen A. Larson's sci-fi series *Battlestar Galactica*. Vipers were the human Colonials' signature starfighters in the protracted conflict against the genocidal mechanical Cylons. This set comes from the collection of veteran model maker Dave Jones. It consists of six production-made green and gold-color cast resin and fiberglass Viper miniature components: three wings; a fuselage; a bottom plate; and an engine. The components exhibit various states of distress with discoloration, snapped-off wing tips, and cracked fiberglass edges from production use. Dimensions: (largest) 15" x 15" x 4" (38.25 cm x 38.25 cm x 10.25 cm)

**Estimate: \$1,200 - 2,400**



**594**  
Hand-Painted Beavis and Butt-Head at Highland High School Animation Cels  
**Beavis And Butt-Head (1993-2011)**

Hand-painted Beavis and Butt-Head at Highland High School animation cels from Mike Judge's comedy-animation series *Beavis and Butt-Head*. MTV gifted cels from the series to Dino Entertainment, the German publisher of the *Beavis and Butt-Head* comic books. This lot consists of two clear acetate cels with Beavis marked "A1.C" and Butt-Head marked "B3.C" hand-painted and stapled to a photocopy image of Highland High School marked "#13 - SC 24." Embossed on the Butt-Head cel is the MTV logo in gold-color. This lot exhibits a torn corner on the Beavis cel. Dimensions: 14" x 11" (35.75 cm x 28 cm) Sold without copyright; see notice in the Buyer's Guide.

**Estimate: \$800 - 1,600**

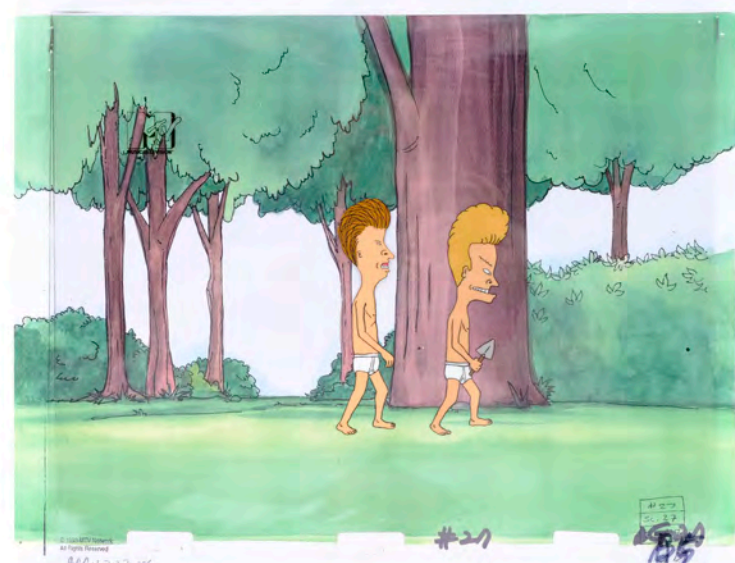

**595**  
Hand-Painted Beavis and Butt-Head in Underwear with Forest Background Animation Cels  
**Beavis And Butt-Head (1993-2011)**

Hand-painted Beavis and Butt-Head in underwear with a forest background animation cels from Mike Judge's comedy-animation series Beavis and Butt-Head. MTV gifted cels from the series to Dino Entertainment, the franchise's comic book publisher. These two clear acetate cels have Beavis marked "A5" and Butt-Head marked "B5" hand-painted in their underwear and Beavis holding a shovel stapled to a photocopy of a forest marked "#27." Embossed on Butt-Head's cel is the MTV logo in gold-color. This lot exhibits the Butt-head cel loose from the staple and Beavis sticks to the background. Dimensions: 14" x 11.5" (35.75 cm x 29.25 cm) Sold without copyright; see notice in the Buyer's Guide.

**Estimate: \$800 - 1,600**

**596**  
Set of Three Fireplace Animation Replacement Pieces  
**Beetlejuice (1988)**

Three fireplace animation replacement pieces from Tim Burton's horror comedy Beetlejuice. Beetlejuice (Michael Keaton) prepared to marry Lydia (Winona Ryder) by summoning a frightful minister from the fireplace after he saved the Maitlands. This lot consists of three fireplace frame pieces. Made of foam painted in shades of gray and teal, these frames feature three levels of increasing angular shapes. They have wood tabs and metal tubes inset in the back and are hand-marked with "1," "14," and "25" in red marker. This lot exhibits discoloration, notable adhesive residue, and notable paint marks. Dimensions: 9.25" x 8.25" x 2" (23.5 cm x 21 cm x 5 cm)

**Estimate: \$1,000 - 2,000**

**597**  
Matted Hand-Illustrated Jack Johnson-Signed "Afterlife" Concept Art  
**Beetlejuice (1988)**

A matted, hand-illustrated Jack Johnson-signed "Afterlife" concept art from Tim Burton's supernatural comedy Beetlejuice. Production used concept art such as this to help finalize designs, such as the Afterlife run by civil servants who committed suicide. This lot consists of one matted art wrapped in plastic with picture wire on the back. Hand-rendered on brown-tone paper, the bottom of the image is titled "Afterlife 'Beetle Juice'" and features Johnson's signature dated for "87." This lot exhibits some smudging, holes in the plastic wrap, discoloration on the matte board, and edgewear. Dimensions: 40" x 30.5" (101.75 cm x 77.5) Sold without copyright; see notice in the Buyer's Guide.

**Estimate: \$2,500 - 5,000**



**598**  
Cast- and Crew-Signed "Malkovich" Diner Menu  
**Being John Malkovich (1999)**

A cast- and crew-signed diner menu from Spike Jonze's surrealist comedy Being John Malkovich. Craig Schwartz (John Cusack) discovered a portal that led into the head of movie star John Malkovich. This lot consists of one folded "Malkovich" menu signed by cast and crew. The signatures include Cameron Diaz, Orson Bean, Charlie Sheen, Catherine Keener, John Cusack, John Malkovich, Mary Kay Place, and the director Spike Jonze with personalized messages to the recipient. The menu features "Malkovich" written as the information on both sides with the centerfold left blank. This lot exhibits crease lines, discoloration, and notable dark spots. Dimensions: 14" x 9" (35.75 cm x 23 cm)

**Estimate: \$800 - 1,600**



**599**  
Gus Fring's (as played by Giancarlo Esposito) Los Pollos Restaurant Suit  
**Better Call Saul (2015-2022)**

Gus Fring's (as played by Giancarlo Esposito) Los Pollos restaurant suit from Vince Gilligan's and Peter Gould's prequel series Better Call Saul. Fring wore his costume as he worked at his chain restaurant Los Pollos Hermanos which also served as a front for his meth distributions. This lot consists of a yellow button-up shirt; beige cotton straight fit pants (size 32 x 34); a brown leather belt (size 34); and a black polyester clip-on tie. Sony Pictures Television will be donating a portion of the sales proceeds from this lot to the Assistance League of Albuquerque and ABQ Mutual Aid of the SouthWest Organizing Project, two local charities located in Albuquerque, New Mexico where Better Call Saul was filmed.

**Estimate: \$2,500 - 5,000**



**600**  
Jimmy McGill's (as played by Bob Odenkirk) "World's 2nd Best Lawyer Again" Beverage Container  
**Better Call Saul (2015-2022)**

Jimmy McGill's (as played by Bob Odenkirk) "World's 2nd Best Lawyer Again" beverage container from Vince Gilligan's and Peter Gould's prequel series Better Call Saul. In Season 6, Kim Wexler (as played by Rhea Seehorn) gave Jimmy another "World's Best Lawyer" beverage container after he completed his probation. This yellow plastic beverage container labeled "World's Best Lawyer" with black decals features a steel base and "2nd" and "Again" added in red text by production to resemble handwriting. It was designed as a prop and is not intended to be used for consumption. The decals exhibit peeling. Dimensions: 4" x 4" x 8" (10.25 cm x 10.25 cm x 20.5 cm) Sony Pictures Television will be donating a portion of the sales proceeds from this lot to the Assistance League of Albuquerque and ABQ Mutual Aid of the SouthWest Organizing Project, two local charities located in Albuquerque, New Mexico where Better Call Saul was filmed.

**Estimate: \$3,000 - 6,000**



**601**  
Gene Takavic (as played by Bob Odenkirk)  
Shoebox of "Diamonds" and Mementos  
**Better Call Saul (2015-2022)**

Gene Takavic (as played by Bob Odenkirk) shoebox of "diamonds" and mementos from Vince Gilligan's and Peter Gould's prequel series Better Call Saul. In the Season 1 episode "Uno," Gene (aka Jimmy McGill and Saul Goodman) obtained a shoebox from a secret compartment in his pantry. This lot consists of a yellow cardboard shoebox with two rubber bands; two VHS tapes; a blue Stonehenge booklet; a green and white photo receipt; a "Best Quality Vacuum Repair" business card; a dark red telephone address book; and a metal band-aid box with faux diamonds. This lot exhibits bends, tears, and grime on the papers and the VHS tapes remain untested for functionality. Dimensions: (largest) 13" x 6.5" x 4" (33 cm x 16.5 cm x 10.25 cm); (smallest) 2.5" x 2" (6.5 cm x 5 cm) Sony Pictures Television will be donating a portion of the sales proceeds from this lot to the Assistance League of Albuquerque and ABQ Mutual Aid of the SouthWest Organizing Project, two local charities located in Albuquerque, New Mexico where Better Call Saul was filmed.

**Estimate: \$2,500 - 5,000**



**603**  
Saul Goodman's (as played by Bob Odenkirk)  
Main Cell Phone  
**Better Call Saul (2015-2022)**

Saul Goodman's (as played by Bob Odenkirk) main cell phone from Vince Gilligan's and Peter Gould's prequel series Better Call Saul. Throughout the series and in the Season 3 episode "Expenses," Goodman used his cell to conduct Saul Goodman Productions business as he served community service in between his law professions. This gray and silver-color plastic cell phone flips up to access the keypad and features a retractable antenna, display screen, and headphone jack. This cell phone exhibits scuffs and grime from production use. Dimensions: 6" x 2" x 1" (15.25 cm x 5 cm x 2.75 cm) Sony Pictures Television will be donating a portion of the sales proceeds from this lot to the Assistance League of Albuquerque and ABQ Mutual Aid of the SouthWest Organizing Project, two local charities located in Albuquerque, New Mexico where Better Call Saul was filmed. Contains electronics; see electronics notice in the Buyer's Guide.

**Estimate: \$1,000 - 2,000**



**602**  
Jimmy McGill's (as played by Bob Odenkirk)  
University of American Samoa Sweatshirt  
**Better Call Saul (2015-2022)**

Jimmy McGill's (as played by Bob Odenkirk) University of American Samoa sweatshirt from Vince Gilligan's and Peter Gould's prequel series Better Call Saul. McGill wore his sweatshirt touting his law degree from the University of American Samoa throughout the series. This gray cotton sweatshirt features a "University of American Samoa Law School 1979" logo printed on front with the Latin motto "Inveniam Viam Aut Faciam," or "I shall either find a way or make one." The sweatshirt exhibits intentional distressing by production to look well-worn and exhibits tears along the collar and sleeves, as well as fading to the logo. Sony Pictures Television will be donating a portion of the sales proceeds from this lot to the Assistance League of Albuquerque and ABQ Mutual Aid of the SouthWest Organizing Project, two local charities located in Albuquerque, New Mexico where Better Call Saul was filmed.

**Estimate: \$1,000 - 2,000**



**604**  
Kim Wexler (as played by Rhea Seehorn)  
and Saul Goodman's (as played by Bob Odenkirk)  
Revenge on Hamlin Components  
**Better Call Saul (2015-2022)**

Kim Wexler (as played by Rhea Seehorn) and Saul Goodman's (as played by Bob Odenkirk) components for their revenge on Hamlin from Vince Gilligan's and Peter Gould's prequel series Better Call Saul. Wexler and Goodman used various components, props, and costumes to end Howard Hamlin's (as played by Patrick Fabian) career and get the Sandpiper case to settle. This lot consists of 51 colored sticky notes with drawings and key words, and a navy cloth and white nylon arm sling with fastening strips. This lot exhibits creases and notable loss of adhesion on the sticky notes. Dimensions: (notes) 3" x 3" (7.75 cm x 7.75 cm) Sony Pictures Television will be donating a portion of the sales proceeds from this lot to the Assistance League of Albuquerque and ABQ Mutual Aid of the SouthWest Organizing Project, two local charities located in Albuquerque, New Mexico where Better Call Saul was filmed.

**Estimate: \$800 - 1,600**



**605**  
Jimmy McGill's (as played by Bob Odenkirk)  
Commercial Director's Shirt  
**Better Call Saul (2015-2022)**

Jimmy McGill's (as played by Bob Odenkirk) commercial director's shirt from Vince Gilligan and Peter Gould's prequel series Better Call Saul. Jimmy wore his director's shirt throughout the series when he directed small businesses' commercials under the guise of Saul Goodman Productions. This green fabric blend dress shirt features faux tortoiseshell buttons down the front and on the sleeves. It exhibits creasing on the collar and hem from production use. Sony Pictures Television will be donating a portion of the sales proceeds from this lot to the Assistance League of Albuquerque and ABQ Mutual Aid of the SouthWest Organizing Project, two local charities located in Albuquerque, New Mexico where Better Call Saul was filmed.

**Estimate: \$500 - 1,000**



**607**  
Sheldon Cooper's (Jim Parsons)  
T.V. Test Pattern Graphic T-Shirt  
**The Big Bang Theory (2007-2019)**

Sheldon Cooper's (Jim Parsons) T.V. test pattern graphic T-shirt from Chuck Lorre and Bill Prady's comedy series The Big Bang Theory. Cooper wore his shirt in various episodes, including at the university cafeteria and in his apartment, throughout the series.

This light blue cotton Hanes T-shirt (size M) with a multicolor T.V. test pattern graphic silk-screened on the front features a tag on the interior hand-marked "WR19." This lot exhibits fading colors from production use.

**Estimate: \$2,000 - 4,000**



**606**  
German Bearer Bond  
**Beverly Hills Cop (1984)**

A German bearer bond from Martin Brest's action comedy Beverly Hills Cop. Detroit detective Axel Foley (Eddie Murphy) flew to Los Angeles, CA after his friend Mikey Tandino (James Russo) was murdered for stealing German bearer bonds from smuggler Victor Maitland (Steven Berkoff). This paper bond is printed on heavyweight off-white stock with a decorative border, an orange eagle emblem, and the text "10,000 Mark" and "Die Banken Frankfurt" printed on the front and German-language disclaimers printed on the reverse. It exhibits a vertical fold line from production. Dimensions: 9.5" x 14.75" (24.25 cm x 37.5 cm)

**Estimate: \$1,000 - 2,000**

**608**  
Leonard Hofstadter's (Johnny Galecki)  
Holiday Pajamas  
**The Big Bang Theory (2007-2019)**

Leonard Hofstadter's (Johnny Galecki) holiday pajamas from the comedy series The Big Bang Theory. In behind-the-scenes photos, Leonard, Sheldon (Jim Parsons), Raj (Kunal Nayyar), Howard (Simon Helberg), and Penny (Kaley Cuoco) posed for photos in their holiday onesies.

This lot consists of a cotton holiday pajama onesie (size S) with a horizontal red-and-green striped Christmas-style pattern with white borders, a green hem, and a green button closure down the front. The inner tag features a hand-marked name that has since been blotted out. Also included is a holiday cap. The costume exhibits no discernable damage.

**Estimate: \$1,500 - 3,000**







**609**  
The Dude's (Jeff Bridges) Light-Up Answering Machine  
**The Big Lebowski (1998)**

The Dude's (Jeff Bridges) light-up answering machine from Joel and Ethan Coen's mystery comedy *The Big Lebowski*. The Dude received messages on his vintage answering machine throughout the film, including when Maude Lebowski (Julianne Moore) called him during an inspection by the LAPD. This lot consists of a wood-paneled Panasonic Easa-Phone automatic telephone answering system with steel and chrome-color plastic buttons and lightbulbs inset labeled "Powering" and "Calls." The lights illuminate red when plugged in via ethernet wiring to a control switch box labeled "Powered," "Blink," and "Steady." The system exhibits some scratching from production use, and its full functionality remains untested. Dimensions: 12" x 8.5" x 3" (30.5 cm x 21.75 cm x 7.75 cm) Contains electronics; see notice in the Buyer's Guide.

**Estimate: \$1,500 - 3,000**



**611**  
Dream Sequence Scissors  
**The Big Lebowski (1998)**

A pair of dream sequence scissors from Joel and Ethan Coen's mystery comedy *The Big Lebowski*. Jeff "The Dude" Lebowski (Jeff Bridges) dreamed of red bodystocking-clad nihilists running after him with oversize scissors. The lot consists of oversize fiberglass and resin left-handed sidebent scissors with a black painted handle and gray painted shears, hinged by a steel bolt covered by a saucer-shaped dome. It exhibits a missing dome as evidenced by the paint silhouette on the reverse side, scratched and chipped paint, oxidation on the bolt, cracking, dust, grime, and discoloration throughout. Dimensions: 60" x 18" x 3" (152.5 cm x 45.75 cm x 7.75 cm)

**Estimate: \$1,500 - 3,000**



**610**  
The Dude's (Jeff Bridges) Keys  
**The Big Lebowski (1998)**

The Dude's (Jeff Bridges) keys from Joel and Ethan Coen's mystery comedy *The Big Lebowski*. Teenager Larry Sellers (Jesse Flanagan) stole The Dude's car while The Dude bowled with his team. This lot consists of two metal Ford-branded keys, a Gino-branded key, and a Silca USA key all attached to the same metal ring. The ring is bent, the keys exhibit tarnishing and some grime from production use and age, and none remain functional as car keys. Dimensions: 2" x 2" x 2" (5 cm x 5 cm x 5 cm)

**Estimate: \$1,500 - 3,000**



**612**  
A Nihilist's (Peter Stormare) Bitten-Off Ear  
**The Big Lebowski (1998)**

A Nihilist's (Peter Stormare) bitten-off ear from Joel and Ethan Coen's mystery comedy *The Big Lebowski*. The leader of the Nihilists had part of his ear bitten off by Walter Sobchak (John Goodman) during the parking lot confrontation outside the bowling alley. This lot consists of a piece of an ear, made of foam with latex skin, painted peach color with red where it was bitten off. The latex exhibits minimal wear from use and age, including cracking along the edges. Dimensions: 2" x 1" x 0.5" (5.25 cm x 2.75 cm x 1.5 cm)

**Estimate: \$1,200 - 2,400**



**613**  
The Big Lebowski's (David Huddleston) Pen  
**The Big Lebowski (1998)**

The Big Lebowski's (David Huddleston) pen from Joel and Ethan Coen's mystery comedy *The Big Lebowski*. The Big Lebowski kept a pen on his desk during his discussion with The Dude (Jeff Bridges) about his urine covered rug. This maroon- and gold-color exterior pen is engraved "Jeffrey Lebowski" along the shaft in gold-color. The pen exhibits scuffing on the cap, the cap fits loose on the shaft, the engraving is fading, and the pen is low on ink. Dimensions: 5.5" x 0.5" x 0.5" (14 cm x 1.5 cm x 1.5 cm)

**Estimate: \$1,000 - 2,000**



**615**  
Maude Lebowski's (Julianne Moore) "Logjammin" VHS with Four Jackie Treehorn (Ben Gazzara) XXX VHS Covers  
**The Big Lebowski (1998)**

Maude Lebowski's (Julianne Moore) "Logjammin" VHS with four Jackie Treehorn (Ben Gazzara) XXX VHS covers from Joel and Ethan Coen's mystery comedy *The Big Lebowski*. Maude pulled her copy of Treehorn's porno "Logjammin" out of a set of other porno tapes to prove Treehorn's connection to her stepmom, Bunny (Tara Reid). This lot consists of a VHS cassette applied with a "Logjammin" decal featuring a "Treehorn Productions" logo and four explicit, production-made XXX VHS covers for films titled "Anus & Andy," "Shevann's Schvanz!," "Fist Fuck Inn," and "American Booty." The covers exhibit corner and edge wear throughout, and the cassette's contents and functionality remain untested. Dimensions: (largest) 9" x 5.75" x 2" (23 cm x 18 cm x 5 cm) Contains mechanical components; see notice in the Buyer's Guide.

**Estimate: \$800 - 1,600**

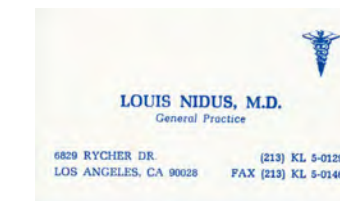
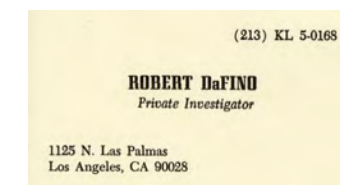

**614**  
Set of Three Production-Made Business Cards  
**The Big Lebowski (1998)**

Three business cards from the production of Joel and Ethan Coen's mystery comedy *The Big Lebowski*. The Dude (Jeff Bridges) met funeral director Francis Donnelly (Warren Keith) to claim Donny's (Steve Buscemi) ashes with Walter Sobchak (John Goodman); fought off nosy private snoop DaFino (Jon Polito); and visited the doctor (Marshall Manesh) on Maude Lebowski's (Julianne Moore) orders. This set consists of production-made business cards labeled for "Robert DaFino, Private Investigator," "Francis Donnelly, Director" of "Pappas & Swain Funeral Directors," and "Louis Nidus, M.D." Each is printed on off-white cardstock with addresses and phone numbers included. The cards exhibit uneven edges from production. Dimensions: (each) 2" x 3.5" (5 cm x 9 cm)

**Estimate: \$800 - 1,600**



**616**  
Set of The Dude's Landlord's (Jack Kehler) Dance Recital Flyers  
**The Big Lebowski (1998)**

Flyers for The Dude's landlord's (Jack Kehler) dance retail from Joel and Ethan Coen's mystery comedy *The Big Lebowski*. The Dude (Jeff Bridges) took Walter Sobchak (John Goodman) and Donny Kerabatsos (Steve Buscemi) to his landlord's dance recital, where attendees were given programs. This set consists of 14 matching black-and-white flyers for "A Dance of Life," each featuring biographical information, a story synopsis, a picture of the landlord, Martin Randahl-Davis, and a credits list with references to the film's real crew, including costume designer Mary Zophres and property master Ritchie Kremer. The flyers are folded by production, and some exhibit minor edge wear. Dimensions: (each) 11" x 4" (28 cm x 10.25 cm)

**Estimate: \$500 - 1,000**



**617**  
Set of Three Production-Made Bowling Name Tags  
**The Big Lebowski (1998)**

Three bowling name tags from the production of Joel and Ethan Coen's mystery comedy *The Big Lebowski*. The Dude (Jeff Bridges), Walter Sobchak (John Goodman), and their fellow bowlers wore name tags as they competed against Jesus Quintana (John Turturro) in the league championship at their favorite alley. This set of black-and-white plastic name tags for "Kate" was created by production, but ultimately unseen on screen. Two tags are bowling pin-shaped, and one is bowling ball-shaped. Metal pins are taped to the backs of all three. The tags exhibit scratching and adhesive residue from production.

**Estimate: \$800 - 1,600**



**618**  
Jesus Quintana (John Turturro) and Liam O'Brien's (James G. Hoosier) Bowling Ball Polishers  
**The Big Lebowski (1998)**

Jesus Quintana (John Turturro) and Liam O'Brien's (James G. Hoosier) bowling ball polishers from Joel and Ethan Coen's mystery comedy *The Big Lebowski*. Quintana and O'Brien enthusiastically polished their equipment while Jeff "The Dude" Lebowski (Jeff Bridges) discussed delivering ransom money to recover a gold-digging wife. This lot of cotton napped flannel cloths with built in handles features Quintana's mustard yellow with burgundy trim one and O'Brien's beige with light brown trim polisher featuring a printed "MASTER BUFF-A-BALL" logo on one side. They exhibit staining, loose threads, and dust from use and conveyance. Dimensions: 10" x 6" x 6" (25.5 cm x 15.25 cm x 15.25 cm)

**Estimate: \$800 - 1,600**



**619**  
Julianne Moore's Chairback  
**The Big Lebowski (1998)**

Julianne Moore's chairback from Joel and Ethan Coen's crime comedy *The Big Lebowski*. Moore portrayed Maude Lebowski, the missing wife of millionaire The Big Lebowski (David Huddleston). This lot consists of a midnight green canvas chairback featuring the film title embroidered in white with a black, green, and orange background. Moore's name is embroidered along the bottom in a white cursive font. This lot exhibits minor discoloration from age. Dimensions: 21.5" x 6.75" x 0.25" (54.75 cm x 17.25 cm x 0.75 cm)

**Estimate: \$500 - 1,000**

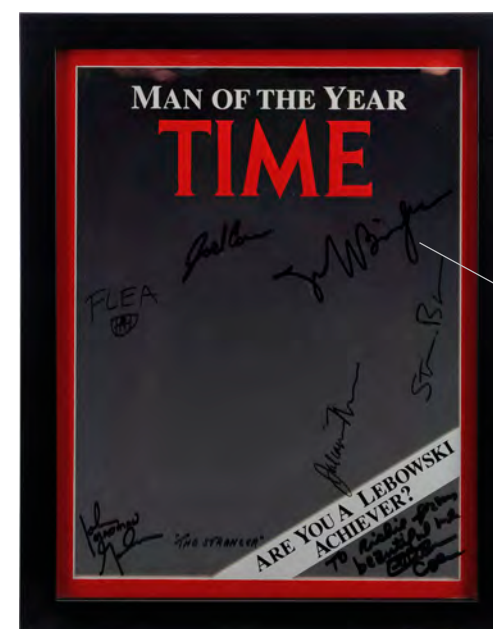

**620**  
Framed Cast-and Crew-Autographed Time Man of the Year Mirror  
**The Big Lebowski (1998)**

A framed cast- and crew-autographed Time Man of the Year mirror from Joel and Ethan Coen's crime-comedy film *The Big Lebowski*. The Big Lebowski (David Huddleston) hung a mirrored Time magazine in his study. This mirror features red and white text "Man of the Year," "Time" and "Are You a Lebowski Achiever?" decals and mounted in a custom-made black wooden frame with a hanging wire. It features signatures by Joel Coen, Julianne Moore, Sam Elliott, Flea, Steve Buscemi, John Goodman, and Jeff Bridges with an annotation "To Ritchie from beautiful me Ethan Coen." It exhibits frame scuffing. Dimensions: 12" x 15.5" x 0.75" (30.5 cm x 39.5 cm x 2 cm)

**Estimate: \$3,000 - 6,000**



**621**  
Bill (Alex Winter) and Ted's (Keanu Reeves) SFX Costume Components  
**Bill & Ted's Bogus Journey (1991)**

Bill (Alex Winter) and Ted's (Keanu Reeves) SFX costume components from Pete Hewitt's sci-fi comedy sequel *Bill & Ted's Bogus Journey*. The evil robot Bill and Ted unzipped their bodies to reveal they swapped their flesh suits in a deleted scene. These costumes consist of one red baseball hat cut in half; one green and black long-sleeve flannel shirt; one yellow cotton short-sleeve T-shirt with a single pocket (size L); one faded orange cotton long-sleeve zip up hoodie (size XL) hand-marked "KY" on its hem and interior tag; one brick-color denim vest with a happy face insignia on the reverse; and one faded red cotton muscle tank top. The hoodie and vest are split up the back and pinned together to keep closed. These costumes exhibit mild discoloration as well as loose and snagged threads from production wear.

**Estimate: \$3,000 - 6,000**



**622**  
Rebreather Prison Mask  
**Black Adam (2022)**

A rebreather prison mask from Jaime Collet-Serra's action fantasy *Black Adam*. Teth Adam (Dwayne Johnson) was captured by the Justice Society and placed underwater in suspended animation with a rebreather. This lot consists of a rubber mask featuring red, black, and clear rubber and nylon tubes extending from the front and secured in the back with fastening strips. This lot exhibits a tape residue on the largest tube around the connection portion.

**Estimate: \$1,500 - 3,000**



**623**  
**Tyrell Corporation**  
**Elevator Model Miniature**  
**Blade Runner (1982)**

A Tyrell Corporation elevator model miniature from Ridley Scott's sci-fi classic Blade Runner. Elevators ran along the futuristic exterior of the massive Tyrell building in 2019 Los Angeles. Created for the film by effects company EEG, this miniature is constructed from cast resin hand-painted charcoal on front with elevated lines around its face. Its reverse is unpainted and inset with a magnet for moving it by hand along the building's exterior. The miniature exhibits small chips to the resin, flaking paint, and white adhesive residue on the reverse. Dimensions: 2.75" x 1.25" x 0.5" (6.75 cm x 3.25 cm x 1.5 cm)

**Estimate: \$2,000 - 4,000**

**624**  
**Set of Four Los Angeles**  
**Cityscape Etching Masters**  
**Blade Runner (1982)**

A set of four Los Angeles cityscape etching masters from Ridley Scott's sci-fi classic Blade Runner. The film's depiction of 2019 Los Angeles was brought to life through compositing model-miniatures, matte paintings, and sets. This lot consists of four pairs of clear plastic sheets with printed black designs. They feature varied informational labels including "Photo Pairs" for "Blade Runner," "Return to Customer" labels, and labels for "Stetson Visual Services," an offshoot of model maker Mark Stetson's Entertainment Effects Group (EEG). This lot exhibits some mild discoloration. Dimensions: (each) 24.5" x 13.5" (62.25 cm x 34 cm)

**Estimate: \$3,000 - 6,000**

**625**  
**John Chambers Collection:**  
**Rutger Hauer Hand Cast**  
**Blade Runner (1982)**

A cast of Rutger Hauer's hand from the production of Ridley Scott's sci-fi classic Blade Runner. In a final act of rebellion against termination, Roy Batty (Rutger Hauer) drove a nail through his own hand while fighting Rick Deckard (Harrison Ford). This rare, original foam latex hand cast comes from the collection of legendary makeup artist John Chambers, who created it to design Batty's hand prosthetic. It is hand-painted with blue veins and ornately detailed knuckles, fingernails, and joints. The latex exhibits extensive cracking and splitting from age and exposure with exposed foam throughout the underside. Dimensions: 12" x 6" x 2" (30.5 cm x 15.25 cm x 5 cm)

**Estimate: \$800 - 1,600**

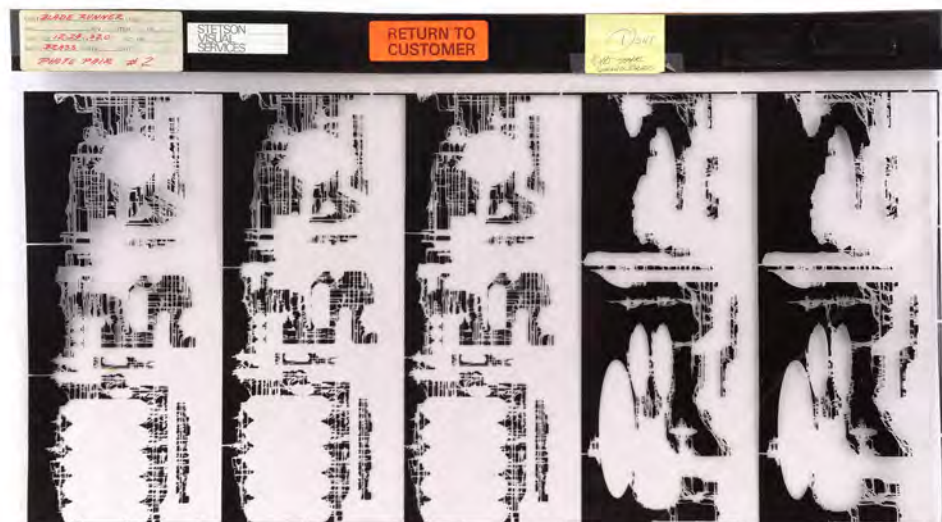

**626**  
**Production-Made Small-Scale**  
**Hades Refinery Etched Brass Sheet**  
**Blade Runner (1982)**

A small-scale Hades refinery etched brass sheet from the production of Ridley Scott's sci-fi classic Blade Runner. Model miniatures etched into brass were used to depict the hellish Los Angeles of 2019, including the flaming refineries that dotted its cityscape in the so-called "Hades landscape" sequence. Created by the EEG model shop for the production but ultimately unfinished, this brass sheet features 17 small-scale rows of brutalist design etchings in the distant shapes of towers, tanks, and buildings. The brass is hole-punched in two places and exhibits dents from use and handling. Dimensions: 24" x 12.25" (61 cm x 31.25 cm)

**Estimate: \$1,000 - 2,000**



**628**  
**Terry Rawlings' Crew Bomber Jacket**  
**Blade Runner (1982)**

Supervising editor Terry Rawlings' crew jacket from the production of Ridley Scott's sci-fi classic Blade Runner. Jackets of this style were gifted to crew members during production as mementos for their work on the film, with this jacket given to Rawlings by Scott himself. This black satin bomber jacket (size L) features the film's title in both English and Japanese embroidered on the back in silver-color and red thread. It exhibits some minor dirt marks on the knitted, ribbed cuffs.

**Estimate: \$500 - 1,000**

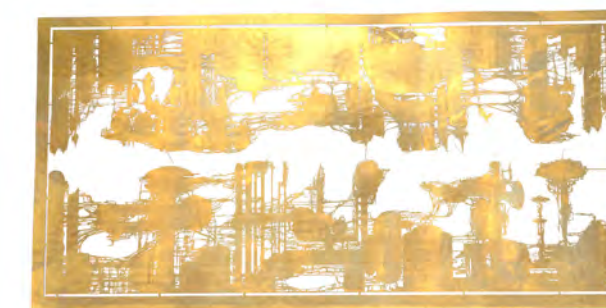

**627**  
**Production-Made Large-Scale**  
**Hades Refinery Etched Brass Sheet**  
**Blade Runner (1982)**

A large-scale Hades refinery etched brass sheet from the production of Ridley Scott's sci-fi classic Blade Runner. Model miniatures etched into brass were used to depict the hellish Los Angeles of 2019, including the flaming refineries that dotted its cityscape in the so-called "Hades landscape" sequence. Created by the EEG model shop for the production but ultimately unfinished, this brass sheet features two mirrored rows of brutalist design etchings of ornately detailed towers, tanks, and buildings. The brass is hole-punched in two places and exhibits dents from use and handling. Dimensions: 24" x 12.25" (61 cm x 31.25 cm)

**Estimate: \$1,000 - 2,000**



**629**  
**Cast-Autographed Limited Edition**  
**Light-Up Replica Rick Deckard Blaster**  
**Blade Runner 2049 (2017)**

A cast-autographed, limited-edition, light-up replica Rick Deckard blaster from Denis Villeneuve's sci-fi sequel Blade Runner 2049. Japanese toy company Tomenosuke manufactured a limited run of 100 metal blasters with fully operational firing mechanisms. This blaster features translucent amber resin grips, multicolor LED lights, and five replica silver- and brass-color bullets. Included is the original Tomenosuke box and printed manual in Japanese and English. The blaster was autographed by Sean Young, Johanna Cassidy, and Rutger Hauer in white marker. This lot exhibits minor box scuffing, a bend in the manual, and mild grime on the pistol. Dimensions: 12" x 8" x 3" (30.5 cm x 20.5 cm x 7.75 cm) Ownership may be restricted in some countries; see replica firearm notice in Buyer's Guide. Contains electronics; see electronics notice in the Buyer's Guide.

**Estimate: \$2,500 - 5,000**



**630**  
**Hannibal King's**  
**(Ryan Reynolds) SFX Pistol**  
**Blade: Trinity (2004)**

Hannibal King's (Ryan Reynolds) SFX pistol from David S. Goyer's action-thriller sequel Blade: Trinity. King wielded his pistol as he battled Drake (Dominic Purcell) and the Vampire Nation. This lot consists of a custom-made pistol cast in metal and plastic. Made to replicate the look of blued steel, the pistol features a small removable mounted scope camera and a holographic computer disc. Powered by three AAA batteries within the barrel, the disc spins continuously when the lower green button on the main body is pressed. This weapon exhibits minor scuffs, notable residue, notable paint marks, chipped paint on the buttons, and rust on the bolts. Dimensions: 11" x 8" x 2" (28 cm x 20 cm x 5 cm) Contains electronics: see electronics notice in the Buyer's Guide.

**Estimate: \$4,000 - 8,000**



**631**  
**Set of Chazz Michael Michaels**  
**(Will Ferrell) and Jimmy MacElroy's**  
**(Jon Heder) Olympic Ephemera**  
**Blades Of Glory (2007)**

Chazz Michael Michaels (Will Ferrell) and Jimmy MacElroy's (Jon Heder) Olympic ephemera from Josh Gordon and Will Speck's sports comedy Blades of Glory. Michaels and MacElroy were stripped of their Olympic medals and credentials after setting the games' mascot on fire. This lot consists of three gold-color medals, two with blue "Stockholm" lanyards and one with a purple "Montreal" lanyard; 23 vinyl buttons promoting Michaels and MacElroy; and four plastic and paper World Wintersport Games credentials labeled for Michaels and MacElroy. The "Montreal" lanyard exhibits tearing, and the credentials exhibit scratching. Dimensions: (largest) 4.5" x 7" x 0.25" (11.5 cm x 18 cm x 0.75 cm)

**Estimate: \$1,000 - 2,000**

**632**  
**Stuart Ziff Collection:**  
**Pair of Model Miniature Figures**  
**The Blob (1988)**

Two model miniature figures from Chuck Russell's sci-fi horror film The Blob. Model miniatures were created for when the Blob swung citizens off the ends of its tentacles. This lot comes from the collection of additional creature effects designer and creator Stuart Ziff. It consists of one foam and latex miniature citizen dressed in polyester clothing and affixed to a small wooden board; and one miniature citizen with a foam head molded around an articulated metal armature with polyester clothing and a plaster finish. Both are intentionally distressed by production to look damaged with cracking and splitting in the foam and plaster, fragility around the joints, and missing hands and feet. Dimensions: 13" x 8" x 6" (33 cm x 20.5 cm x 15.25 cm)

**Estimate: \$1,200 - 2,400**



13" (33 cm)



**633**  
**Rollergirl's (Heather Graham)**  
**Costume Components with Bowtie**  
**Boogie Nights (1997)**

Rollergirl's (Heather Graham) costume components with a bowtie from Paul Thomas Anderson's drama film Boogie Nights. Rollergirl wore her costume during Becky Barnett's (Nicole Ari Parker) and Jerome's (Michael Jace) wedding reception. This lot consists of a pair of black polyester tuxedo shorts; a pair of black and white Spandex roller skate covers with black carved resin buttons; a black and purple polyester bowtie; and four production tags. This lot exhibits stains on the covers and discoloration on the bowtie from age.

**Estimate: \$1,000 - 2,000**



**634**  
**Rollergirl's (Heather Graham)**  
**Costume Components with Shorts**  
**Boogie Nights (1997)**

Rollergirl's (Heather Graham) costume components with shorts from Paul Thomas Anderson's drama film Boogie Nights. Rollergirl wore her costume while working at the Hot Traxx Club. This lot consists of green cotton flower and butterfly embroidered shorts; a pair of brown, gold, and white wool thunderbolt long socks; a gold-colored metal chain necklace with a rainbow enamel charm; three production tags; and six wardrobe breakdown sheets in protector sleeves. This lot exhibits discoloration on the socks.

**Estimate: \$1,000 - 2,000**



**635**  
**Jack Horner's (Burt Reynolds)**  
**Brown Robe and Shorts**  
**Boogie Nights (1997)**

Jack Horner's (Burt Reynolds) brown robe and shorts from Paul Thomas Anderson's drama film Boogie Nights. Horner wore his costume when he joined Eddie Adams (Mark Wahlberg) and Reed Rothchild (John C. Reilly) in the jacuzzi. This lot consists of a rust orange polyester blend robe with a matching belt; a pair of rust orange polyester-blend shorts; and three production tags. This lot exhibits minor stains on the robe.

**Estimate: \$1,000 - 2,000**



**636**  
**Jack Horner's (Burt Reynolds) Costume**  
**Boogie Nights (1997)**

Jack Horner's (Burt Reynolds) costume from Paul Thomas Anderson's comedy-drama Boogie Nights. Horner wore his suit as he greeted Colonel James (Robert Ridgely) at his pool party. This costume consists of a cotton cream-color four-pocket button up shirt (size L) with colorful thread accents and wooden buttons; cream-color trousers with an internal tag on the waistband with "Burt Reynolds" printed on it; a gold-color chain bracelet; five production tags hand-marked "Boogie Nights," "Jack" "SC 49" and "SC 50-51." Also included are two pages of production printed wardrobe breakdown logs for Jack dated "6/27/96." This costume exhibits discoloration and notable rusting on the metal fasteners.

**Estimate: \$800 - 1,600**



**638**  
**Gold Dracula Coin**  
**Bram Stoker's Dracula (1992)**

A gold Dracula coin from Francis Ford Coppola's Gothic horror adaptation of Bram Stoker's Dracula. In deleted scenes, Jonathan Harker (Keanu Reeves) stole gold-color coins during his escape from Dracula's (Gary Oldman) castle, and offered them to nuns in a nearby cathedral. This gold-color metal coin features Vlad III/Dracula's face and ancient text on one side, and the Dracula family's dragon crest on the other side. Also included is a Columbia/Sony Pictures Certificate of Authenticity. The coin exhibits minimal scuffing from use and age. Dimensions: 1.25" x 1.25" x 0.25" (3 cm x 3 cm x 0.75 cm)

**Estimate: \$1,500 - 3,000**

76" (193 cm)



**637**  
**Hand-Painted Neighborhood Matte Painting**  
**The Boy Who Could Fly (1986)**

A hand-painted neighborhood matte painting from Nick Castle's fantasy drama The Boy Who Could Fly. Eric (Jay Underwood) and Milly (Lucy Deakins) flew into the sky and watched fireworks up in the clouds. This lot consists of one hand-painted matte painting of a neighborhood at night on a metal framed acrylic panel. The frame bottom features a plaque with the film's name. A piece of tape is faintly marked "DS 10." This lot exhibits scuffing, notable paint marks, chipped paint, and adhesive residue. Dimensions: 76" x 34" x 0.5" (193 cm x 86.5 cm x 1.25 cm) Special shipping required; see notice in the Buyer's Guide. Sold without copyright; see copyright notice in the Buyer's Guide.

**Estimate: \$1,000 - 2,000**



**639**  
**Printed Mentor Huebner**  
**Dracula's Castle Concept Illustration Brownline**  
**Bram Stoker's Dracula (1992)**

A printed brownline of a concept illustration of Dracula's castle made by production illustrator Mentor Huebner for Francis Ford Coppola's Gothic horror adaptation Bram Stoker's Dracula. Jonathan Harker (Keanu Reeves) raced to Dracula's (Gary Oldman) castle with Dr. Jack Seward's (Richard E. Grant) men shooting at him. This brownline depicting an early concept illustration of the castle shootout is labeled "Old Version No. 1 To Be Changed" and features Huebner's signature printed in the left corner. It comes mounted to a gray backing board. The brownline exhibits fading text and some discoloration, and the backing board exhibits extensive water damage. Dimensions: 22" x 28" (56 cm x 71.25 cm) Sold without copyright; see copyright notice in the Buyer's Guide.

**Estimate: \$300 - 600**

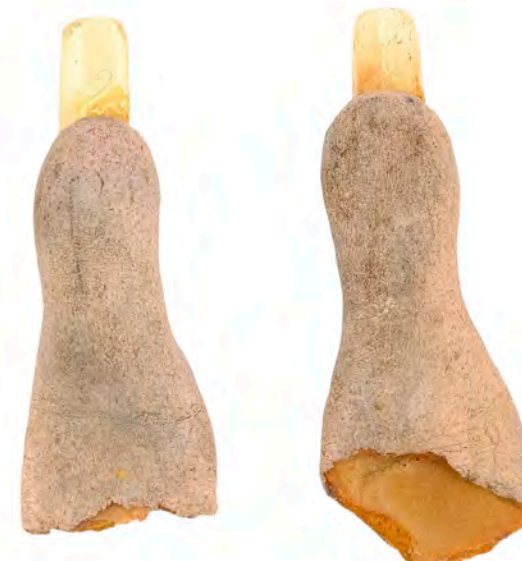

**640**  
**Dracula's (Gary Oldman)**  
**Finger Appliances**  
**Bram Stoker's Dracula (1992)**

Dracula's (Gary Oldman) finger appliances from Francis Ford Coppola's Gothic horror adaptation of Bram Stoker's Dracula. Prior to arriving in London, Dracula appeared as an old man while Jonathan Harker (Keanu Reeves) arranged his real estate affairs. This lot consists of two finger appliances. Made of foam latex with acrylic nails, these appliances feature a rounded knuckle joint painted in various shades of yellow and brown to appear sallow and aged. This lot features some cracking and flaking, notable adhesive residue, and lifted adhesive. Dimensions: (each) 1" x 2.5" x 0.5" (2.5 cm x 6.5 cm x 1.25 cm)

**Estimate: \$800 - 1,600**



**641**  
**William Wallace's**  
**(Mel Gibson) Screen-Matched**  
**Antler Hand Weapon**  
**Braveheart (1995)**

William Wallace's (Mel Gibson) screen-matched antler hand weapon from Mel Gibson's historical drama Braveheart. Distressing made by production to this weapon screen-matches it to when Wallace attacked English soldiers with an antler weapon. This antler hand weapon is made of brown painted, carved, and textured resin to resemble a real antler horn. The carvings create groves for the fingers and the palm of the hand. This lot exhibits minor sprays of stage blood, minor rough edges, and residue from molding. Dimensions: 8.5" x 7.5" x 2.5" (21.75 cm x 19 cm x 6.5 cm)

**Estimate: \$2,000 - 4,000**



**642**  
**Deed of Succession**  
**Braveheart (1995)**

A Deed of Succession from Mel Gibson's historical drama Braveheart. Robert the Bruce (Angus Macfadyen) was to be presented with a Deed of Succession to the Scottish Throne for the deliverance of William Wallace (Mel Gibson). This deed is printed on distressed cardstock with a detailed "Deed of Succession of the Scottish Throne" along the header and the remaining portion of the deed printed in Latin. The deed features three resin "wax" stamped seals over red nylon. This lot exhibits tears along the edges and grime on the seals. Dimensions: 24" x 19.5" (61 cm x 49.75 cm)

**Estimate: \$2,000 - 4,000**



**643**  
Murrion Wallace's (Catherine McCormack) Screen-Matched Animal Skin Message **Braveheart (1995)**

Murrion Wallace's (Catherine McCormack) screen-matched animal skin message from Mel Gibson's Oscar-winning medieval biopic *Braveheart*. The tears and drawing imperfections screen-match the animal skin message William Wallace (Mel Gibson) gifted Murrion during their courtship.

This lot consists of a drawing on real animal hide featuring a lined star, a crescent moon, and a couple holding hands while standing under a tree. This lot exhibits a grime, discoloration and chipping paint, and a red residue from age. Dimensions: 13" x 10.5" x 1.5" (33 cm x 26.75 cm x 4 cm)

**Estimate: \$3,000 - 6,000**



**644**  
Parchment Messages **Braveheart (1995)**

Parchment messages from Mel Gibson's Oscar-winning medieval biopic *Braveheart*. Prince Edward (Peter Hanly) read an urgent message from York informing the King (Patrick McGoohan) that William Wallace (Gibson) sacked York. This lot consists of two double-layered parchment messages featuring resin seals. They mention Wallace's victories over York and over a small cavalry he trapped in a bog. This lot exhibits tears and creases from production use, black residue from the seals, and one message with notable loss of adhesion between the layered parchment. Dimensions: (each) 10.25" x 7" (26.25 cm x 18 cm)

**Estimate: \$2,000 - 4,000**

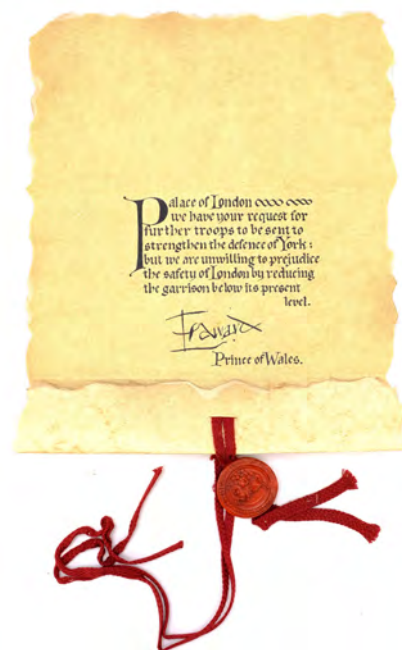

**645**  
Parchment Message with Letter Seals **Braveheart (1995)**

A parchment message with letter seals from Mel Gibson's historical drama *Braveheart*. The Governor of York (Richard Leaf) received a parchment message from the Prince of Wales (Peter Hanly) denying his request for soldiers to defend York. This lot consists of a paper message wrapped in a red polyester cord with a red resin seal and four burgundy resin stamped "wax" seals. This lot exhibits intentional creases and tears along the parchment and grime to the letter's seal. Dimensions: (parchment) 10.5" x 5.5" x 1" (26.75 cm x 14 cm x 2.75 cm); (seal) 1.25" x 1.25" (3.25 cm x 3.25 cm)

**Estimate: \$800 - 1,600**



**646**  
Stephen of Ireland's (David O'Hara) Screen-Matched Double-Bladed Buckler **Braveheart (1995)**

Stephen of Ireland's (David O'Hara) screen-matched double-bladed buckler from Mel Gibson's Oscar-winning medieval biopic *Braveheart*. The leather imperfections along the edge screen-match this buckler to the one Stephen wielded alongside fellow Scotsmen in the fight against English soldiers. This wooden buckler with dual wooden blades is applied with a leather cover and features metal details painted silver-color and black. It exhibits peeling leather on the front and grime from production use. Dimensions: 25.25" x 10" x 2.5" (64.25 cm x 25.5 cm x 6.5 cm)

**Estimate: \$2,000 - 4,000**



**648**  
Stephen of Ireland's (David O'Hara) Stunt Scottish War Hammer **Braveheart (1995)**

Stephen of Ireland's (David O'Hara) stunt Scottish war hammer from Mel Gibson's historical drama *Braveheart*. Stephen used his hammer in the Battle of Stirling Bridge against the English with William Wallace (Mel Gibson). This lot consists of a hammer made of a rubber hammerhead, metal braces, and a wooden handle. The hammerhead has four short prongs on one side and a spike on the other. Along the handle is a label from production marked "Stephen: - Stirling [sic]." It exhibits intentional distressing by production and restoration work post-production on the hammerhead and is very fragile. Dimensions: 31.25" x 10" x 1.25" (79.5 cm x 25.5 cm x 3.25 cm)

**Estimate: \$1,500 - 3,000**



**647**  
Stephen of Ireland's (David O'Hara) Metal Sword **Braveheart (1995)**

Stephen of Ireland's (David O'Hara) metal sword from Mel Gibson's historical drama *Braveheart*. Stephen of Ireland wielded his sword to protect William Wallace (Mel Gibson) from Faudron's (Jimmy Chisholm) sneak attack. This metal sword features a rounded wooden pommel painted silver-color and a leather covered handle. Along the blade is a label from production marked "Stephen 122A Onwards" on masking tape. This lot exhibits wear from age on the leather and chipping paint on the pommel. Dimensions: 22.5" x 5.75" x 2" (57.25 cm x 14.75 cm x 5 cm) Blade was dulled after production.

**Estimate: \$1,500 - 3,000**



**649**  
Stephen of Ireland's (David O'Hara) Dagger **Braveheart (1995)**

Stephen of Ireland's (David O'Hara) dagger from Mel Gibson's historical drama *Braveheart*. Stephen wielded his dagger in the Battle of Stirling against the English. This lot consists of a rubber dagger with a metal base featuring a flat, rounded hand guard and pommel. Attached to the blade is a label from production, "Stephen: - Stirling." This lot exhibits paint chipping and wear from production use. Dimensions: 15" x 2" x 2" (38.25 cm x 5.25 cm x 5.25 cm)

**Estimate: \$1,000 - 2,000**



**650**  
 Hamish's (Brendan Gleeson) Long-handled Stunt Ax  
**Braveheart (1995)**

Hamish's (Brendan Gleeson) long-handled stunt ax from Mel Gibson's historical drama Braveheart. Hamish carried and used his long-handled axe in the battle against the English with William Wallace (Mel Gibson). This lot consists of a long-handled ax made of a rubber blade and a wooden handle. Along the handle is a label from production marked "Double For Hamish." This lot exhibits distressing from production use. Dimensions: 32" x 9" x 1.75" (81.5 cm x 23 cm x 4.5 cm)

**Estimate: \$1,000 - 2,000**



**651**  
 Wooden Targe  
**Braveheart (1995)**

A wooden targe from Mel Gibson's Oscar-winning medieval biopic Braveheart. Scotsmen wielded wooden targes in the fight against the English soldiers. This lot consists of a wooden targe with metal bolts for detailing and leather straps on the reverse. This lot exhibits intentional distressing on the wood and metal from production. Dimensions: 24.5" x 24.5" x 3" (62.25 cm x 62.25 cm x 7.75 cm)

**Estimate: \$800 - 1,600**



**652**  
 Walter White's (Bryan Cranston) Black Jacket  
**Breaking Bad (2008-2013)**

Walter White's (Bryan Cranston) black jacket from Vince Gilligan's crime thriller series Breaking Bad. White wore a black jacket when he assumed his Heisenberg persona. This black polyester and nylon zip-front golf jacket (size Large) features long sleeves with adjustable cuffs and a polyester mesh inner liner. It is hand-marked "WALT" in black on the hang loop. The jacket exhibits scuffing at cuff buttons with off-white discolorations at the cuff and arm.

**Estimate: \$2,000 - 4,000**



**653**  
 Walter White's (Bryan Cranston)  
 Goggles and Respirator  
**Breaking Bad (2008-2013)**

Walter White's (Bryan Cranston) safety goggles and respirator from Vince Gilligan's crime thriller series Breaking Bad. As a science teacher at J.P. Wynne High School, White kept safety accessories in his classroom throughout the series until he was fired and brought them home in the Season 3 episode "Green Light." He also wore safety goggles and a respirator when he cut through the floor of his house in the Season 2 episode "Over." This lot consists of a gray rubber and plastic respirator mask with white elastic bands and a pair of clear safety goggles with a black elastic band. Production intentionally distressed this respirator and goggles. The mask and goggles exhibit visible scratches, scuffs, and discoloration.

**Estimate: \$3,000 - 6,000**



**654**  
 Walter White's (Bryan Cranston)  
 and Syklar White's (Anna Gunn) Burner Phones  
**Breaking Bad (2008-2013)**

Walter White's (Bryan Cranston) and Syklar White's (Anna Gunn) burner phones from Vince Gilligan's crime thriller series Breaking Bad. Walt used and destroyed several secret phones throughout the series to operate his crystal meth business as Heisenberg. This lot consists of one chrome-color flip phone and one navy-blue and chrome-color phone. Production purposefully removed and covered the mobile carrier names on the phones. The pair exhibits scratching and discoloration from production use, and both are currently nonfunctional. Dimensions: (each) 3" x 3" x 1" (7.75 cm x 7.75 cm x 2.75 cm) Contains electronic components; see notice in the Buyer's Guide.

**Estimate: \$1,000 - 2,000**



**655**  
 Yellow Radio-Controlled Toy Car  
**Breaking Bad (2008-2013)**

A yellow radio-controlled toy car from Vince Gilligan's crime thriller series Breaking Bad. Radio-controlled cars appeared throughout the series, including when Marie Schrader (as played by Betsy Brandt) accidentally destroyed one in the Season 2 episode "Seven Thirty-Seven." This plastic toy comes with two 9.6V battery packs, a charger, and a 9V battery-powered radio control that flashes red when charged and operating the car's four wheels. The toy's metal antenna is cut, its body exhibits black stains, and its wheels are sticky from production use. Dimensions: 16" x 17" x 8" (40.75 cm x 43.25 cm x 20.5 cm) Contains electronic components; see notice in the Buyer's Guide.

**Estimate: \$600 - 1,200**

**656**  
Walter White's (Bryan Cranston) White T-Shirt  
**Breaking Bad (2008-2013)**

Walter White's (Bryan Cranston) T-shirt from Vince Gilligan's crime thriller series Breaking Bad. White wore a variety of outfits throughout the series, often with a plain white T-shirt underneath. This lot consists of a white cotton Hanes crewneck T-shirt (size L) hand-marked "Walt" and a Sony Certificate of Authenticity. A studio-issued Certificate of Authenticity from Sony Pictures Television is included. The shirt exhibits minor signs of wear in the form of fabric pilling and hem wear.



**Estimate: \$500 - 1,000**

**658**  
Whitney's (Nicole Bilderback) Rancho Carne High Cheerleader Uniform  
**Bring It On (2000)**

Whitney's (Nicole Bilderback) Rancho Carne High cheerleader uniform from Peyton Reed's teen comedy Bring It On. Whitney and her fellow cheerleaders wore their uniforms while cheering for Rancho Carne High School and in national competition. This lot consists of a red polyester top with black-and-white striping and "RCH" on the chest, and a matching polyester skirt. Both are hand-marked "Whitney." They exhibit a few loose threads around the edges.



**Estimate: \$1,200 - 2,400**

**657**  
Walter White's (Bryan Cranston) Gray Pants  
**Breaking Bad (2008-2013)**

Walter White's (Bryan Cranston) gray pants from Vince Gilligan's crime thriller series Breaking Bad. White wore a variety of different formal outfits throughout the series. These gray polyester-cotton blend Dockers classic fit pants are hand-marked "WALT" in black ink on the waistband above the manufacturer's label. A studio-issued Certificate of Authenticity from Sony Pictures Television is included. The trousers exhibit minor discoloration marks on both the interior and exterior from production use.



**Estimate: \$500 - 1,000**

**659**  
Darcy's (Tsiarina Joelson) Rancho Carne High Cheerleader Uniform  
**Bring It On (2000)**

Darcy's (Tsiarina Joelson) Rancho Carne High cheerleader uniform from Peyton Reed's teen comedy Bring It On. Darcy and her fellow cheerleaders wore their uniforms while cheering for Rancho Carne High School and in national competition. This lot consists of a red acrylic top with black-and-white striping and "RCH" on the chest, a matching polyester skirt, a long-sleeve red nylon undershirt, and black nylon briefs with a red "Toros" logo. All four are hand-marked "Darcy." They exhibit a few loose threads around the edges.



**Estimate: \$1,500 - 3,000**



**660**  
Bruce Lee's Jeet Kune Do Yin-Yang Lapel Pin  
**Bruce Lee**

Bruce Lee's self-designed lapel pin, which he gifted to select senior students and instructors. The front of the metal pin features a red and yellow yin-yang symbol and Chinese script engraved in black. The script translates as "Using no way as way," and "Having no limitation as limitation." The lapel pin comes in the original paper packet of its Hong Kong manufacturer. Accompanying the pin is a 2015 letter of authenticity from Lee's student and best friend, the late Sifu Taky Kimura. The lot exhibits minor signs of wear, including a tear in the packet. Dimensions: (packet) 9" x 5" (3.5 cm x 2 cm); (pin) 0.75" x 0.75" x 0.5" (2 cm x 2 cm x 1 cm)

**Estimate: \$2,000 - 4,000**

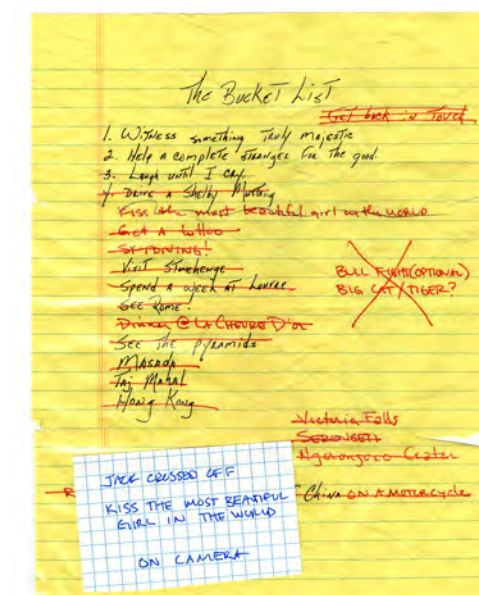

**661**  
Edward Cole (Jack Nicholson) and Carter Chambers' (Morgan Freeman) Handwritten Torn Bucket List Page  
**The Bucket List (2007)**

Edward Cole (Jack Nicholson) and Carter Chambers' (Morgan Freeman) handwritten and torn bucket list page from Rob Reiner's comedic drama The Bucket List. Terminally ill billionaire Cole tore up the bucket list he made with Chambers as the end of his life drew nearer. This sheet of lined yellow U.S. letter-sized paper is hand-titled "The Bucket List" and annotated in black and red ink, with lines crossed out to indicate a completed task. The page exhibits intentional tearing by production in several places, crumpling, and tape repaired. Dimensions: 8.5" x 11" (21.75 cm x 28 cm)

**Estimate: \$600 - 1,200**



**662**  
Bugsy Siegel's (Warren Beatty) Jacket  
**Bugsy (1991)**

Bugsy Siegel's (Warren Beatty) jacket from Barry Levinson biographical crime drama Bugsy. American gangster Siegel was a driving force behind the creation of the Las Vegas Strip. This classic houndstooth pattern woolen Eisenhower jacket (size 42) features a black satin lining with a hidden pocket, button front, and flap-pockets. A yellowed Western Costume tag sewn inside the hidden pocket features typewritten details: "2791-1," "WARREN BEATTY," chest "42," and sleeve "18 1/2." The lot includes six separate garment tags from previous owners, some hand-marked with notations relating to the actor and his role in the film. The jacket is not seen in the film's final cut. The jacket exhibits pilling and minor loose threads, and the garment tags exhibit minor edgewear and discoloration due to age.

**Estimate: \$3,000 - 6,000**





**663**  
Briefcase with Money and Gold Bar  
**Bullet Train (2022)**

A briefcase with money and a gold bar from David Leitch's comedy-thriller film *Bullet Train*. Five assassins killed each other over a money and gold-filled briefcase that was used as a ransom for the White Death's (Michael Shannon) son. This lot consists of a metal briefcase with a three-digit dial combination lock and two blue train stickers; 16 \$100 bundles; a gold-color painted and gold-color vinyl coated resin stamped gold bar; and a 12 \$100,000 certificates paperclipped and secured to the briefcase's pockets. This lot exhibits imperfections and minor grime to the gold bar. Dimensions: 16" x 13" x 3.5" (40.75 cm x 33 cm x 9 cm)

**Estimate: \$3,000 - 6,000**



**664**  
Set of Hitmen Accessories  
**Bullet Train (2022)**

Hitmen accessories from David Leitch's action comedy *Bullet Train*. Ladybug (Brad Pitt) beat ring-clad hitmen with several unusual weapons, including brass knuckles, off from a mysterious briefcase on a bullet train. This set consists of four faux gold and faux silver signet rings, one inset with a faux sapphire and three engraved with hitmen call signs, including a hornet and a lemon; faux brass brass knuckles with ridged details; and a non-functional Mercedes-Benz key fob. The fob exhibits a missing key and the metals exhibit tarnishing throughout from production. Dimensions: (largest) 4.5" x 2.5" x 0.5" (11.5 cm x 6.5 cm x 1.5 cm)

**Estimate: \$1,200 - 2,400**



**665**  
The Elder's (Hiroyuki Sanada)  
Solid Cane  
**Bullet Train (2022)**

The Elder's (Hiroyuki Sanada) screen-matched cane from David Leitch's action comedy *Bullet Train*. This cane screen-matches to when The Elder and Ladybug (Brad Pitt) found Lemon (Brian Tyree Henry) alive in the bullet train bathroom. This brown wooden cane features metal rivets, a scallop-textured metal collar and heel, and a urethane crane's head handle painted beige. It exhibits mild tarnished metal and chipping paint from production use. Dimensions: 35" x 6" x 1.25" (89 cm x 15.25 cm x 3.25 cm)

**Estimate: \$1,000 - 2,000**



**666**  
Set of 3 The Wolf's (Bad Bunny) Stunt Knives  
**Bullet Train (2022)**

Three of "The Wolf's" (Bad Bunny) stunt knives from David Leitch's action comedy *Bullet Train*. Assuming that Ladybug (Brad Pitt) was one of his wife's (Andrea Munoz) killers, Wolf engaged in a one-sided knife fight. This lot includes three knife variations: one resin and two wire-encased rubber blades with resin handles. All are painted silver-color, gray, ivory, and black to resemble metal and bone. The full resin and a rubber with resin knife exhibits a cut-off tip. The knives exhibit minor scratches, scuffs, and paint chipping. Dimensions: (largest) 12.25" x 2.5" x 1.75" (31.25 cm x 6.5 cm x 4.5 cm)

**Estimate: \$800 - 1,600**



**668**  
Lemon's (Brian Tyree Henry) Blue Train Stickers and Sticker Set with Train Card and Parking Placard  
**Bullet Train (2022)**

Lemon's (Brian Tyree Henry) blue train stickers and sticker set with train card and parking placard from David Leitch's action comedy *Bullet Train*. Hitman Lemon used stickers from his favorite children's show to teach his opponents valuable lessons and used a blue train sticker to mark the ransom briefcase. This lot consists of a sheet of color-printed, unpeeled Thomas the Tank Engine & Friends stickers; two production-made blue and white unpeeled train stickers; a multicolor plastic bullet train card dated "5-8-2021" with serial number "9676588"; and a multicolor plastic parking placard labeled "Bullet Train." The stickers exhibit some creasing from production. Dimensions: (largest) 7.5" x 10.5" (19.25 cm x 26.75 cm)

**Estimate: \$600 - 1,200**



**667**  
Ladybug's (Brad Pitt) Stabbed Phone with The Wolf's (Bad Bunny) Knife  
**Bullet Train (2022)**

Ladybug's (Brad Pitt) Stabbed Phone with The Wolf's (Bad Bunny) Knife from David Leitch's comedy-thriller film *Bullet Train*. The Wolf wielded his knife when he attacked Ladybug (Brad Pitt) and stabbed his phone by mistake. This lot consists of a silver-color painted rubber knife covered in stage blood with a brown-painted textured handle, a gold-color painted handguard and pommel with red and black vinyl details placed through a black glass digital phone with silver-color and bronze-color painted cellophane and secured with resin. It exhibits glue residue and peeling vinyl. Dimensions: 12" x 6" x 3" (30.5 cm x 15.25 cm x 7.75 cm) Contains electronics; see electronics notice in the Buyer's Guide.

**Estimate: \$800 - 1,600**



**669**  
Dick Miller's Crew Jacket  
**The 'Burbs (1989)**

Dick Miller's crew jacket from the production of Joe Dante's dark comedy *The 'Burbs*. Dick Miller, a regular in Dante's films, appeared as a garbageman in a cameo alongside fellow Dante regular Robert Picardo. This red, white, and blue bomber jacket (size M) is hand-marked "Dick Miller" on the interior and embroidered "The Burbs" on the front left chest. It features two front pockets, red metal snap buttons, and an elastic collar, sleeves, and hem. The jacket exhibits various signs of wear, including staining throughout and pilling to the elastic, but retains its vintage coloration.

**Estimate: \$500 - 1,000**



**670**  
**Production-Made "Recompensa! Bandidos Yanquis" Poster**  
**Butch Cassidy And The Sundance Kid (1969)**

A production-made poster headlined "Recompensa! Bandidos Yanquis" from the production of George Roy Hill's Western drama Butch Cassidy and The Sundance Kid. Posters calling for the arrest of Butch (Paul Newman) and Sundance (Robert Redford) lined a Bolivian bank wall they robbed. Created by Earl Hays Press for the production, this black-and-white Spanish-language paper poster dated "Julio 13 de 1903" features illustrations of Butch and Sundance labeled "Bandidos de Los Estados Unidos" with a message from the Governor of La Paz and an offer of "Mil Pesos Bolivianos" for their capture. It exhibits some discoloration and a pinhole in the top right corner from production. Dimensions: 10.25" x 18" (26.25 cm x 45.75 cm)

**Estimate: \$400 - 800**



**672**  
**Candyman/Daniel Robitaille's (Tony Todd) Stunt Hook**  
**Candyman: Farewell To The Flesh (1995)**

Candyman/Daniel Robitaille's (Tony Todd) stunt hook from Bill Condon's supernatural horror sequel Candyman: Farewell to the Flesh. The Candyman gutted Paul McKeever's (Timothy Carhart) from groin to gut, killing him. This lot consists of a resin hook painted and shaped to look like old, rusted wrought iron. This weapon features a plastic plate at the bottom attached with a screw for special effects capability. Production intentionally distressed this hook to give it an aged appearance. This lot exhibits scratching on the plastic plate, mild bending, some discoloration, and a cracked tip on the hook. Dimensions: 7" x 7" x 3.5" (18 cm x 18 cm x 9 cm)

**Estimate: \$2,000 - 4,000**



**671**  
**Ice Monster Maquette**  
**Cabin Boy (1994)**

A maquette of the ice monster from Adam Resnick's fantasy comedy film Cabin Boy. The crew of The Filthy Whore battled an ice monster and finally defeated it with a spray of hot coffee. The original maquette was deteriorating so a mold was created from it following production and a new casting was made to preserve the sculpt. This lot comes from the collection of Doug Beswick, an artist known for his stop-motion animation and creature effects work. It consists of a resin casting of a sculpture of the ice monster secured to a wooden base. The base bottom has some hand-written lettering ("hil") remaining from whatever it was cut out from. The figure exhibits rear staining. Dimensions: 7.25" x 10" x 8" (18.5 cm x 25.5 cm x 20.5 cm)

**Estimate: \$600 - 1,200**



**673**  
**Cast-Autographed Final Draft Script**  
**The Carol Burnett Show: A Reunion (1993)**

A cast-autographed final draft script from the documentary-musical television special The Carol Burnett Show: A Reunion. This copy of the final draft script is dated October 12, 1992 with 17 pages of filming schedules and notes and 85 pages of script following. The script features a blue cardstock cover with the title and autographs from Carol Burnett, Harvey Korman, Lyle Waggoner, and Tim Conway in black ink and an autograph from Vicki Lawrence in gold-color ink. This lot exhibits minor wrinkles to the back page from storage. Dimensions: 8.5" x 11" x 0.5" (21.75 cm x 28 cm x 1.5 cm)

**Estimate: \$800 - 1,600**



**674**  
**Set of Tangiers Chips**  
**and Casino Accessories**  
**Casino (1995)**

Tangiers chips and casino accessories from Martin Scorsese's mob drama Casino. Ace Rothstein (Robert De Niro) was assigned to manage the Chicago Outfit's interests at the Tangiers Hotel & Casino in Las Vegas. This lot consists of seven plastic casino chips in \$1, \$5, \$25, \$100, and \$500 increments; a plastic stirring stick; two sheets of cream-color hotel stationery; and two parking claim tickets, all printed with the Tangiers logo. The paperwork exhibits discoloration from age, while the chips exhibit stains and grime from production use. Dimensions: (largest) 8.5" x 11" (21.75 cm x 28 cm)

**Estimate: \$2,000 - 4,000**



**675**  
**Chuck Noland's (Tom Hanks) Knife**  
**Cast Away (2000)**

Chuck Noland's (Tom Hanks) knife from Robert Zemeckis' adventure drama Cast Away. Chuck Noland created tools when he crash landed on a deserted island. This lot consists of a sculpted resin knife between two pieces of wood and secured together by twine. This lot exhibits extensive glue residue throughout. Dimensions: 8.75" x 1.75" x 1" (22.25 cm x 4.5 cm x 2.75 cm)

**Estimate: \$800 - 1,600**

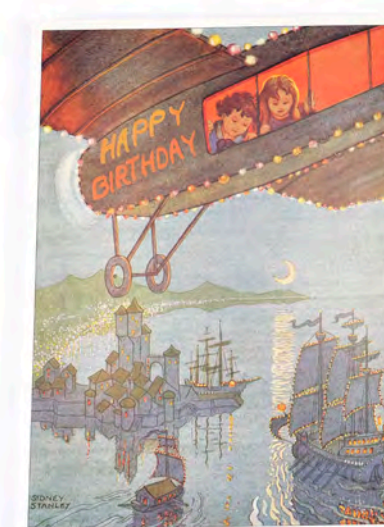

**676**  
**Handwritten Plane Crash**  
**Birthday Card**  
**Cast Away (2000)**

A handwritten plane crash birthday card from Robert Zemeckis' drama Cast Away. Chuck Noland (Tom Hanks) read the Wallace Stevens quote "The most beautiful thing in the world is, of course, the world itself" from a birthday card on the desert island where he crash-landed. This lot consists of a color greeting card printed with a Sidney Stanley illustration on front and Stevens' quote on the interior. It is hand-signed "Johnny, Have the happiest birthday ever! Score! Your Grandpa" in blue pen. Also included is a white envelope hand-labeled "Johnny" in matching script. Both exhibit edge wear and light creasing. Dimensions: 5" x 7" (12.75 cm x 18 cm)

**Estimate: \$1,200 - 2,400**



**677**  
Frank Abagnale, Jr.'s (Leonardo DiCaprio) Satchel  
**Catch Me If You Can (2002)**

Frank Abagnale, Jr.'s (Leonardo DiCaprio) satchel from Steven Spielberg's biographical crime caper *Catch Me If You Can*. Con artist Abagnale carried his satchel throughout the film as a vestige of his true identity. This empty brown canvas satchel with light brown leatherette detailing and a dark brown leather-bound handle features a paper tag hand-marked "FRANK ABAGNALE JR. 53 TRABER RD. NEW ROCHELLE, NY" and a locking brass buckle. It exhibits staining on the canvas and torn leatherette around the edges from production use. Dimensions: 14" x 12" x 1.5" (35.75 cm x 30.5 cm x 4 cm)

**Estimate: \$1,500 - 3,000**



**678**  
Set of Frank Abagnale, Jr.'s (Leonardo DiCaprio)  
"Frank Roberts" Blank Pan Am Checks  
**Catch Me If You Can (2002)**

Frank Abagnale, Jr.'s (Leonardo DiCaprio) "Frank Roberts" blank Pan Am checks from Steven Spielberg's biographical crime caper *Catch Me If You Can*. Carl Hanratty (Tom Hanks) traced Abagnale by following a trail of checks he cashed under a fraudulent name. This set consists of six matching blank checks with perforated edges, the Chase Manhattan Bank logo printed in their bottom left corners, and the Pan Am logo printed above and watermarked throughout each. The checks exhibit discoloration, creasing, and minor tears from production. Dimensions: (each) 8.5" x 3.5" (21.5 cm x 9 cm)

**Estimate: \$1,500 - 3,000**



**679**  
Frank Abagnale Jr.'s (Leonardo DiCaprio) Briefcase  
**Catch Me If You Can (2002)**

Frank Abagnale, Jr.'s (Leonardo DiCaprio) screen-matched briefcase from Steven Spielberg's biographical crime caper *Catch Me If You Can*. This briefcase screen-matches to when Abagnale met up with his father Frank (Christopher Walken). This briefcase is composed of an aluminum frame in brown synthetic leather with gold-color hardware. It features two top locks, hinge joints, and two interior pockets. The interior is lined in brown canvas with diamond patterns. This lot exhibits some loose threads, creases, scuffs, and discoloration on the metal. Dimensions: 18" x 13" x 4" (45.75 cm x 33 cm x 10.25 cm)

**Estimate: \$1,500 - 3,000**



**680**  
Set of Annotated Continuity Photos  
**Catch Me If You Can (2002)**

459 annotated continuity photos from the production of Steven Spielberg's biographical crime caper *Catch Me If You Can*. These photos depicted Frank Abagnale, Jr. (Leonardo DiCaprio), Carl Hanratty (Tom Hanks), and other key characters, costumes, props, and sets replete with hand-marked annotations denoting scene numbers and other continuity notes in the margins. The photos are hung on three metal binder rings. The set exhibits creasing, bending, edge wear, discoloration, and color fade. Dimensions: 4" x 4" x 5.5" (10.25 cm x 10.25 cm x 14 cm)

**Estimate: \$1,500 - 3,000**

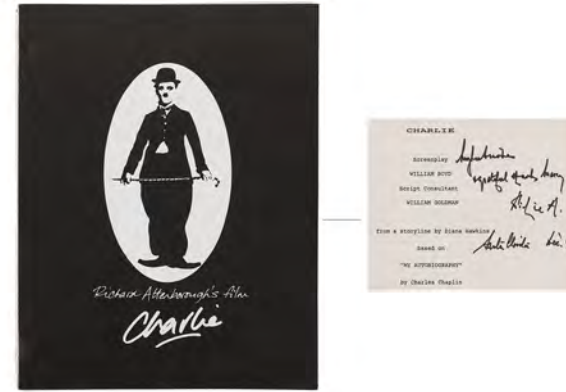

**681**  
Original Richard Attenborough-inscribed  
Shooting Script  
**Chaplin (1992)**

An original Richard Attenborough-inscribed shooting script from the production of Attenborough's biographical comedy-drama *Chaplin*. The 124-page script, dated "September 1991," is printed on white, blue, pink, and yellow paper. It has been studio bound and bradded in a black card cover featuring a graphic image of Chaplin as the "Little Tramp" and the film's working title, "Charlie." The title page includes an inscription from Attenborough reading, "Highest wishes & grateful thanks Marcy, Dickie A., Santa Clarita Dec. 91," handwritten in black pen. Accompanying this script is a behind-the-scenes, black-and-white production still of the movie set. The script exhibits minor staining and edge wear from production use. Dimensions: (script) 11" x 8.5" x 0.75" (28 cm x 21.5 cm x 2 cm)

**Estimate: \$2,000 - 4,000**



**683**  
Set of Four Wonka Bars  
**Charlie And The Chocolate Factory (2005)**

Four Wonka bars from Tim Burton's musical fantasy *Charlie and the Chocolate Factory*. Stacks of Wonka bars appeared in various locations around the globe as the world hunted for five elusive Golden Tickets. The injection-molded brown plastic bars feature a "Wonka" logo imprinted on each segment. Each is covered in silver-color foil and a colorful wrapper indicating its flavor. The front of each bar features a printed seal reading, "Win a trip to Wonka's Chocolate Factory," and nutritional information presented on the back. Some bars exhibit glue residue and minor staining. Dimensions: (each) 3.75" x 7.25" x 0.5" (9.5 cm x 18.5 cm x 1 cm)

**Estimate: \$1,000 - 2,000**



**682**  
Golden Ticket and Fudgemallow Delight Wonka Bar  
**Charlie And The Chocolate Factory (2005)**

A golden ticket and Fudgemallow Delight Wonka Bar from Tim Burton's fantasy adventure *Charlie and the Chocolate Factory*. Five lucky children toured Willy Wonka's (Johnny Depp) factory after finding elusive golden tickets in Wonka bar wrappers. The gold-color foil paper ticket displays an embossed stamp and black text. The Wonka bar is made of injection-molded brown plastic and covered in silver-color foil with a brown wrapper indicating its flavor. A printed seal on the rapper front reads, "Win a trip to Wonka's Chocolate Factory." The wrapper exhibits marks. Dimensions: (ticket) 3.25" x 7" (8 cm x 18 cm); (bar) 3.75" x 7.5" x 0.5" (9.5 cm x 19 cm x 1 cm)

**Estimate: \$2,000 - 4,000**

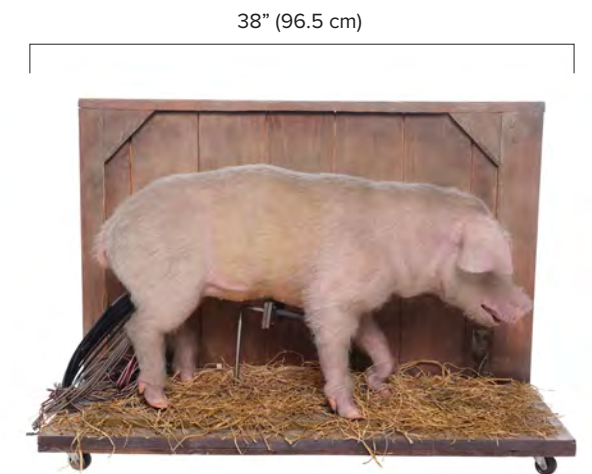

**684**  
Animatronic Wilbur Puppet Display  
**Charlotte's Web (2006)**

An animatronic Wilbur puppet from Gary Winick's fantasy comedy drama *Charlotte's Web*. Charlotte (Julia Roberts) wove webs with words to save Wilbur's (Dominic Scott Kay) life so he would live to old age. Originally made by Legacy Effects, this lot consists of one silicone puppet with hand-punched hair. It features a metal armature and wires for servo-control that extend outside the body. It comes with a custom-made display with hay to give the appearance of a barn. This puppet has undergone sympathetic repair. This lot exhibits silicone fragility from age with mild tearing and separation. Dimensions: 38" x 16" x 27" (96.5 cm x 40.75 cm x 68.5 cm) Contains mechanical components; see notice in the Buyer's Guide.

**Estimate: \$2,000 - 4,000**



**685**  
E. Johnson's (Melanie Griffith)  
Costume and Wig  
Cherry 2000 (1987)

E. Johnson's (Melanie Griffith) costume and wig from Steve De Jarnatt's action-comedy film Cherry 2000. Johnson wore her costume as she traveled with Sam Treadwell (David Andrews) to find him a new android wife. This lot consists of a pink suede fringe jacket; a dark green suede shirt; olive-green leather trousers; a red synthetic wig; and an 8" x 10" (20.32 cm x 25.40 cm) color movie still of Griffith in her costume and wig. This lot exhibits a tear in the trousers' waistband.

**Estimate: \$1,500 - 3,000**



**686**  
Production-Made  
Good Guys Doll Costume  
Child's Play 2 (1990)

A production-made Good Guys doll costume from John Lafia's horror sequel Child's Play 2. The Play Pals Corporation re-released its line of identical Good Guys dolls to recover from the damaging publicity caused by Chucky (Brad Dourif) in Child's Play. This costume was created for the production, but ultimately unseen in the final cut. It originated from the collection of Andy Barclay's (Alex Vincent) photo double, Joshua Krippner. The costume features a striped cotton blend onesie with blue corduroy overalls with two red plastic buttons and "Good Guys" embroidered on the front. Also included is a Letter of Authenticity from Krippner. The sleeves and ankles are pre-rolled, and the overalls exhibit intentional distressing with grime applied by production.

**Estimate: \$4,000 - 8,000**



**687**  
Set of The Fly, Arachnophobia,  
and Child's Play Promotional  
Transparencies  
Various Productions

Three color transparencies, one each from the promotional campaigns of The Fly, Arachnophobia, and Child's Play. Due to their ornate detail and vividness of color, transparencies were created during the proofing process for poster art. These textless cellulose acetate transparencies depict Richard Mahon's one-sheet art for The Fly, John Alvin's one-sheet art for Arachnophobia, and the one-sheet art for Child's Play. Each is numbered on the sides, and the Child's Play transparency features sprocket holes and a color bar in the margins. They exhibit print errors in the margins. Dimensions: (each) 8" x 10" (20.5 cm x 25.5 cm)

**Estimate: \$1,000 - 2,000**



**688**  
Mr. Tumnus' (James McAvoy) Scarf and Packages  
The Chronicles Of Narnia:  
The Lion, The Witch And The Wardrobe (2005)

Mr. Tumnus' (James McAvoy) scarf and packages from Andrew Adamson's fantasy-adventure film The Chronicles of Narnia: The Lion, the Witch and the Wardrobe. Mr. Tumnus wore his scarf when he carried packages home before meeting Lucy Pevensie (Georgie Henley). This lot consists of a crocheted red wool scarf with long fringe; one brown paper cylinder package with twine; two brown paper bottle packages attached together and decorated with twine; and one brown paper rectangular package wrapped in twine and red wax. This lot exhibits minor scuffs and dents from production use and age. Dimensions: 13.5" x 4" x 4" (34.5 cm x 10.25 cm x 10.25 cm)

**Estimate: \$2,500 - 5,000**

**690**  
Minotaur's Ax  
The Chronicles Of Narnia:  
The Lion, The Witch And  
The Wardrobe (2005)

A minotaur's ax from Andrew Adamson's fantasy adventure The Chronicles of Narnia: The Lion, the Witch and the Wardrobe. Minotaurs fought with the White Witch (Tilda Swinton) during the Battle of Beruna. This foam rubber ax was built over a metal internal structure to give it weight and stability and has been painted gray and brown to simulate metal and wood. The blade has intricate decorative designs and has been given some distressing from production to make it appear aged and battle-worn. It exhibits some scuffing to the foam finish from use. Dimensions: 59.5" x 11" x 2.5" (151.25 cm x 28 cm x 6.5 cm)

**Estimate: \$1,200 - 2,400**



**689**  
Minotaur Maquette  
The Chronicles Of Narnia:  
The Lion, The Witch And  
The Wardrobe (2005)

A minotaur maquette from the production of Andrew Adamson's fantasy film The Chronicles of Narnia: The Lion, The Witch and the Wardrobe. Visual effects artists used maquettes to design Narnia's many extraordinary creatures, including minotaurs. Created by KNB EFX Group, this ornately detailed cast resin maquette with a staff in its hands is painted in shades of gray and gold-color to resemble clay and metal, and mounted to a wooden display base. Its tail broke off following production and was since reconnected, exhibiting a visible fracture. Dimensions: 10" x 7" x 15" (25.5 cm x 18 cm x 38.25 cm)

**Estimate: \$600 - 1,200**



**691**  
Telmarine Soldier  
Costume  
The Chronicles Of Narnia:  
Prince Caspian (2008)

A Telmarine soldier's costume from Andrew Adamson's epic fantasy film The Chronicles of Narnia: Prince Caspian. Telmarines battled for the crown in uniforms. Made by legendary effects company Weta, this costume consists of a metal helmet with fiberglass mask; a gray leather and polyblend lace-up undershirt; a long-sleeve vinyl chainmail shirt; a gray canvas and navy blue velour studded coat; a gray studded leather vest; a chest plate; gauntlets; two leather belts; a leather pouch; gray polyester jodhpurs; black leather boots (size 10); and shin guards hand-marked for "Long R" and "Long L." This costume exhibits scuffing, discoloration, and fragile seams.

**Estimate: \$1,000 - 2,000**





**692**  
**Riddick's (Vin Diesel) Planet U.V.6 Costume**  
**The Chronicles Of Riddick (2004)**

Riddick's (Vin Diesel) Riddick's (Vin Diesel) Planet U.V.6 costume from David Twohy's sci-fi action sequel The Chronicles of Riddick. Riddick wore his costume while he escaped Toombs' (Nick Chinlund) mercenaries in the wasteland of Planet 6 in the U.V. System. This costume consists of a multicolor cloak made of synthetic fur pelts, leather, and a cotton and suede shoulder section; a multi-tone brown leather poncho; a brown leather jacket with neoprene accents; a brown cotton shirt with leather accents and a gray cotton mesh bib; brown leather gloves with straps and fur accents; brown cargo trousers marked "Vin" on the interior; black cotton and rubber boots with leather and plastic covers; and black rubber replica goggles with plastic lenses. It exhibits wear and white stage snow staining throughout, and missing fur sections on the cloak and gloves.

**Estimate: \$3,000 - 6,000**

**693**  
**Destroyed Rescue Helicopter**  
**Model Miniature Tail Section**  
**Cliffhanger (1993)**

A destroyed rescue helicopter model miniature tail section from Renny Harlin's action-adventure Cliffhanger. Ranger Gabe Walker (Sylvester Stallone) thwarted Eric Qualen (John Lithgow) by tying a winch line, which resulted in a crash. The tail section is fiberglass-backed resin, painted white and orange, with black tail numbers as well as "RES" and "CUE" on either side, and vinyl pinstriping with an aged appearance. The broken-off resin tail rotor is painted blue and silver, with metal armature attached to a rotor-box. The lot exhibits paint chipping, cracking, jagged edges, and a broken-off piece (included). Dimensions: (largest) 41" x 12" x 5.5" (104.25 cm x 30.5 cm x 14 cm)

**Estimate: \$1,500 - 3,000**

**694**  
**Dave Jones Collection:**  
**Rescue Helicopter Model Miniature Cockpit**  
**Cliffhanger (1993)**

A rescue helicopter model miniature cockpit from Renny Harlin's action thriller Cliffhanger. Ranger Gabe Walker (Sylvester Stallone) thwarted thief Eric Qualen (John Lithgow) by tying a winch line from the rescue helicopter Qualen attempted to escape in, resulting in a crash against the nearby rock face. This lot comes from the collection of veteran model maker Dave Jones. It consists of a 1/4-scale fiberglass and resin helicopter cockpit model miniature; 11 miniature cockpit pieces; two Cineflex booklets; 31 behind-the-scenes photographs; a wood base; and a smaller Huey helicopter model miniature. The cockpit was purposefully distressed by production. This lot exhibits scratches, scuffs, a buildup of grime, and discoloration. Dimensions: (largest) 12.5" x 13.5" x 10" (31.75 cm x 34.5 cm x 25.5 cm)

**Estimate: \$600 - 1,200**

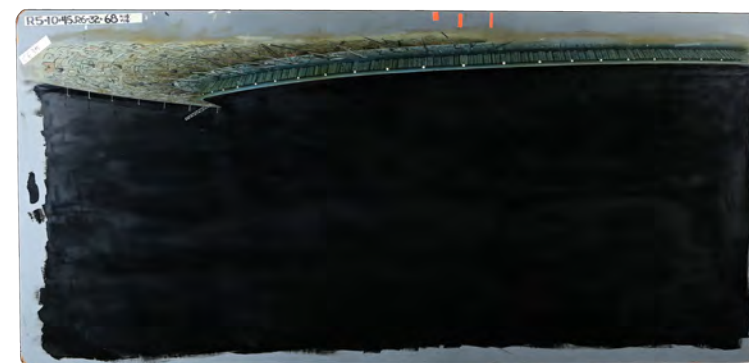

**695**  
**Hand-Painted Matthew Yuricich**  
**Mothership Top Finale Landing Matte Painting**  
**Close Encounters Of The Third Kind (1977)**

A hand-painted Matthew Yuricich Mothership Top finale landing matte painting from Steven Spielberg's sci-fi classic Close Encounters of the Third Kind. This matte painting was used when the alien mothership touched down at the military base on Devil's Tower. This painting features acrylic paints on masonite with a black wash for live-action photography overlap and is labeled "R5-10+45", "R6-32+68" and "H=6 V=6." It features the names of the crew hidden in the top panels, including Douglas Trumbull, Larry Albright, Richard Yuricich, and Stephen Spielberg. It exhibits minor chipping around the edges. Dimensions: 80.25" x 38" x 0.25" (204 cm x 96.5 cm x 0.5 cm) Sold without copyright; see notice in the Buyer's Guide. Special shipping required; see notice in the Buyer's Guide.

**Estimate: \$3,000 - 6,000**



**696**  
**Starry Sky and Muncie, Indiana Projection Plate**  
**Close Encounters Of The Third Kind (1977)**

Starry Sky and Muncie, Indiana projection plates from Steven Spielberg's sci-fi drama Close Encounters of the Third Kind. UFOs passed through Muncie, Indiana, and caused a power outage. Actors stood in front of images projected from the plates. This lot consists of a translucent film between two glass plates taped together, featuring an image of Muncie, Indiana, beneath a dark starry sky. The plate is marked "Aug. 1, 76 Plate - 8" and "Front." This lot exhibits marks on the glass and tape, fading, ripping on the edge, and smudging. Dimensions: 10" x 8" x 0.25" (25.5 cm x 20.5 cm x 0.75 cm)

**Estimate: \$1,000 - 2,000**



**697**  
**Three Matted Production Stills**  
**with Hand-Painted Overlays**  
**Close Encounters Of The Third Kind (1977)**

A set of three matted production stills with handpainted overlays from Steven Spielberg's sci-fi drama Close Encounters of the Third Kind. Roy Neary (Richard Dreyfuss) and others witnessed a group of small UFOs. This lot originates from the collection of Douglas Trumbull, the visual effects pioneer responsible for the film's effects. This lot features three production stills on black matboard, featuring various model miniatures depicting car-occupied roads and people-occupied park areas. Each piece features various hand-painted black and gray overlays, with one of the stills featuring a horizontal red linemark terminating mid-way. The lot exhibits minor edgewear. Dimensions: (each) 14.5" x 9.5" x 0.25" (37 cm x 24.25 cm x 0.75 cm)

**Estimate: \$1,500 - 3,000**

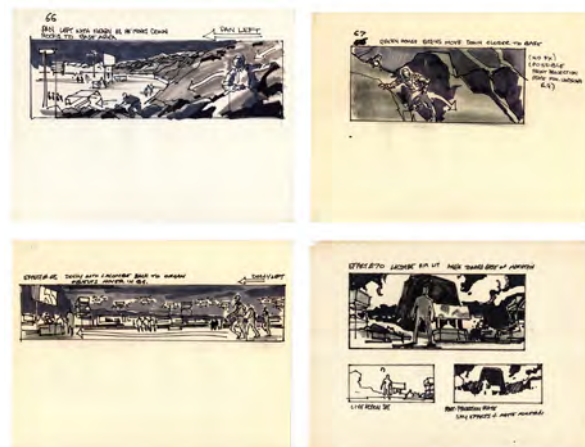

**698**  
Set of Four Hand-Drawn George Jenson Devil's Tower VFX Storyboards  
**Close Encounters Of The Third Kind (1977)**

Four Devil's Tower VFX storyboards hand-drawn by George Jenson for Steven Spielberg's sci-fi film Close Encounters of the Third Kind. Claude Lacombe (Francois Truffaut) awaited the Mothership as Roy Neary (Richard Dreyfuss) and Jillian Guiler (Melinda Dillon) scaled Devil's Tower. Created by Jenson to coordinate which VFX were needed in the landing sequence, this set consists of four storyboards numbered "66," "67," "Effect 68," and "Effect 70." Each is annotated and rendered in ink and watercolors on serrated drawing paper. The set exhibits torn corners and pinholes. Dimensions: 11.75" x 9" (30 cm x 23 cm) Sold without copyright. See notice in the Buyers Guide.

**Estimate: \$1,200 - 2,400**



**700**  
Dave Jones Collection: Production-Made Mothership Model Miniature Components  
**Close Encounters Of The Third Kind (1977)**

Mothership model miniature components made for the production of Steven Spielberg's sci-fi drama Close Encounters of the Third Kind. The alien mothership returned abductees at Devil's Tower in Wyoming. This lot comes from the collection of veteran model maker Dave Jones. It consists of one reddish-brown-painted foam and gel-layer upper-panel quarter-section; three silver-painted metallic components; a silver-painted resin component with red acrylic rods in holes; three clear acrylic rods with domed end-caps; a wood block with black masking tape; and an L-bent, U-shaped halogen bulb. The lot exhibits pitting, scratches, chipping, and cracking. Dimensions: (largest) 14" x 14" x 1.5" (35.5 cm x 35.5 cm x 4 cm)

**Estimate: \$800 - 1,600**

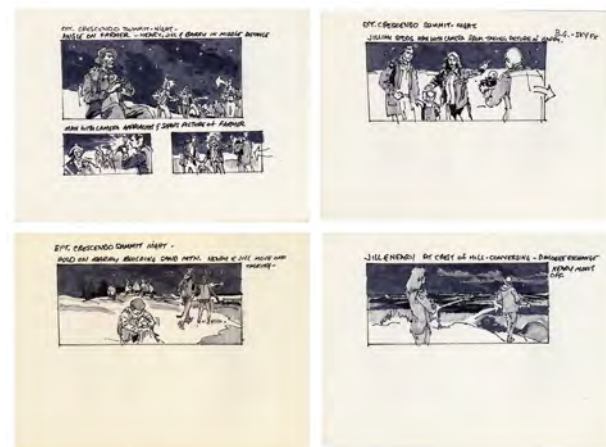

**699**  
Set of Four Hand-Drawn George Jenson Crescendo Summit Storyboards  
**Close Encounters Of The Third Kind (1977)**

Four Crescendo Summit storyboards hand-drawn by George Jenson for Steven Spielberg's sci-fi film Close Encounters of the Third Kind. Locals gathered at Crescendo Summit in hopes of seeing the extraterrestrial vessels that visited their town. This set consists of four sheets of illustration paper with effects storyboards hand-rendered in mixed media, including black ink and marker on sheets of thick white illustration paper, with brief handwritten descriptions throughout, and rough edges from where the pages were torn out of a spiral-bound drawing pad. This lot exhibits some discoloration, pin holes in the corners, and pencil smudging. Dimensions (each): 9" x 11.75" (23 cm x 30 cm) Sold without copyright; see copyright notice in the Buyer's Guide.

**Estimate: \$800 - 1,600**



**701**  
Dave Jones Collection: Advanced Space Shuttle Model Miniature with Ephemera  
**CN Tower**

An advanced space shuttle model miniature with related ephemera from the production of the Canadian National Tower's futuristic simulation ride Tour of the Universe. This lot comes from the collection of veteran model maker Dave Jones. It consists of a fiberglass model miniature shuttle labeled "CANADA," inset with electronic wiring, and painted gray and white; a "CP Air" Interplanetary pamphlet lanyard; a holographic boarding pass; two detached blaster panels; and a vinyl Canadian maple leaf sticker. The shuttle exhibits cracking and is currently non-functional. Dimensions: (largest) 19" x 18" x 3.5" (48.5 cm x 45.75 cm x 9 cm) Contains electronics; see electronics notice in the Buyer's Guide.

**Estimate: \$1,500 - 3,000**



**702**  
Ron Cobb Hand-Drawn Raider Commander Artwork  
**Conan The Barbarian (1982)**

A Ron Cobb hand-drawn artwork depicting the raider commander from John Milius' action adventure Conan the Barbarian. Production designer Cobb rendered the illustration, an early concept for the raiders who massacred Conan's (Arnold Schwarzenegger) village. Drawn with pastels and watercolors on illustration paper and custom-framed, the mixed media artwork depicts a helmeted warrior brandishing a sword and shield. Although the design for the raiders ultimately changed, the helmet design was kept for the raider commander. This lot exhibits pin holes at the corners and perimeter tape residue. Dimensions: 28" x 19.25" x 0.25" (71 cm x 49 cm x 1 cm) Sold without copyright; see notice in the Buyer's Guide.

**Estimate: \$1,500 - 3,000**

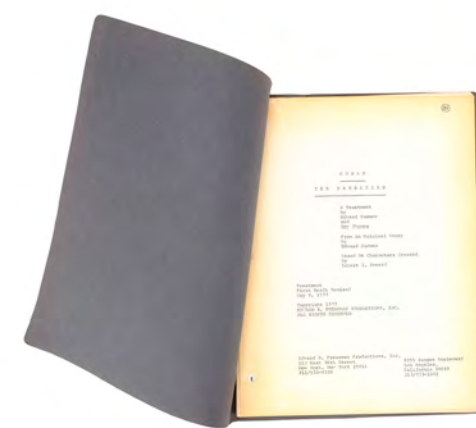

**704**  
First Draft Treatment  
**Conan The Barbarian (1982)**

A first draft treatment from John Milius' action-adventure film Conan the Barbarian. This 78-page revised first draft is a treatment by Edward Summer and Roy Thomas and based on the characters created by Robert E. Howard. The draft is dated May 9, 1977 and comes in a black plastic cover with the film title embossed in yellow and a black label "CONAN" along the spine. This lot exhibits major discoloration and fading ink throughout from age and loose pages from a missing cover pin. Dimensions: 9" x 11.5" x 0.5" (23 cm x 29.25 cm x 1.5 cm)

**Estimate: \$800 - 1,600**



**703**  
Hand-Drawn John Bloomfield Conan Costume Design  
**Conan The Barbarian (1982)**

A costume design for Conan the Barbarian (Arnold Schwarzenegger) hand-drawn by costume designer John Bloomfield for John Milius' fantasy adventure Conan the Barbarian. Bloomfield created this artwork of Conan in a red tasseled robe and gold-color gauntlets with collaged magazine and paper clippings applied to A3 paper and touched-up with graphite. It is hand-labeled "Conan, Costume 11, Arnold Schwarzenegger," backed with foam core, and signed and dated "John Bloomfield 1980" in the bottom right corner. The foam exhibits torn paper residue on tape around the margins. Dimensions: 13.5" x 18.5" (34.5 cm x 47 cm) Sold without copyright; see notice in the Buyer's Guide.

**Estimate: \$1,500 - 3,000**



**705**  
Adonis Creed's (Michael B. Jordan) Gloves with Stunt Boxing Costume Components  
**Creed (2015)**

Adonis Creed's (Michael B. Jordan) gloves with stunt boxing costume components from Ryan Coogler's sports drama Creed. Creed competed as "Donnie Johnson" in his first high-profile boxing match against Leo "The Lion" Sporno (Gabriel Rosado). This lot consists of two black Grant lace-up boxing gloves with ink markings on the left glove's interior; black-and-white satin stunt boxing shorts with patches emblazoned "JOHNSON" and "SHAMROCK MEATS INC."; a black foam-padded stunt groin guard; two black-and-white mesh and leather stunt boxing shoes (U.S. size 8); and a handwritten wardrobe tag labeled for a stunt performer. The gloves exhibit flaking from the removal of tape during production.

**Estimate: \$2,500 - 5,000**



**706**  
Hand-Drawn Ron Frenz Transition  
"Something to Tide You Over" Comic Artwork  
**Creepshow (1982)**

A hand-drawn Ron Frenz transition "Something to Tide You Over" comic artwork from George A. Romero's fantasy-horror film Creepshow. At the end of "The Lonesome Death of Jordy Verrill," the skeletal ghost Creep addressed the reader in transition to the next segment "Something To Tide You Over." This hand-drawn comic features Creep in black and blue lines making a sand castle with a printed comic panel and Creep's printed speech bubble. The comic panel and speech bubble are glued over the hand-drawn comic. Along the footer of the printed page are handwritten notes "1 5/5 1 5 3/4 WIDE" and "56 1/2." This lot exhibits white-out residue around the border and discoloration from glue residue. Dimensions: 12" x 18" (30.5 cm x 45.75 cm) Sold without copyright; see notice in the Buyer's Guide.

**Estimate: \$5,000 - 10,000**



**709**  
Hand-Painted "Father's Day" Ending Animation Cel  
**Creepshow (1982)**

A hand-painted "Father's Day" ending animation cel from George A. Romero's fantasy-horror film Creepshow. At the end of the segment "Father's Day," Cass Blaine (Elizabeth Regan) and Richard Grantham (Warner Shook) discover Nathan Grantham's corpse (John Amplas) with the severed head of their Aunt Sylvia Grantham (Carrie Nye). This acetate cel features printed comic book panels with the last panel hand-painted in reds, purples, and blues. This lot exhibits a minor tear along the top. Dimensions: 11.75" x 16.5" (30 cm x 42 cm) Sold without copyright; see notice in the Buyer's Guide.

**Estimate: \$1,500 - 3,000**



**710**  
Hand-Painted Opening Credits Creep  
Animation Cel with Background  
**Creepshow (1982)**

A hand-painted opening credits Creep animation cel from George A. Romero's fantasy-horror film Creepshow. The animated skeletal ghost Creep flew over Billy's (Joe Hill) house during the opening credits of the film. This hand-painted acetate animation cel features a blue and yellow skeletal ghost over a printed and hand-colored background. The cel is marked "S-67" and the background is taped to a paper with a handwritten "12." This cel exhibits sticking to the background in the painted section. Dimensions: 13" x 11.25" (33 cm x 28.75 cm) Sold without copyright; see notice in the Buyer's Guide.

**Estimate: \$2,000 - 4,000**



**707**  
Hand-Painted "The Lonesome Death of Jordy Verrill"  
Ending Animation Cel  
**Creepshow (1982)**

A hand-painted "The Lonesome Death of Jordy Verrill" ending animation cel from George A. Romero's fantasy-horror film Creepshow. At the end of the segment "The Lonesome Death of Jordy Verrill," Jordy Verrill (Stephen King) shot himself to stop the infectious spread from the meteor. This acetate cel features two printed comic book panels and two cut printed panels with the last panel hand-painted in blues, greens, and browns. This lot exhibits a minor tear along the top. Dimensions: 12" x 10.25" (26 cm x 30.5 cm) Sold without copyright; see notice in the Buyer's Guide.

**Estimate: \$2,500 - 5,000**



**711**  
Hand-Painted Animation Cel of  
Carnivorous Plants with Print Background  
**Creepshow 2 (1986)**

A hand-painted animation cel of carnivorous plants with a printed background from Michael Gornick's fantasy-horror film Creepshow 2. Billy (voiced by Domenick John) led his neighborhood bullies to his giant carnivorous venus flytrap plants. This hand-painted acetate cel features green-color plants with yellow teeth, swinging around a bully by his shirt. The cel is marked "SC 4.36" and "P 43" and taped to a red-color printed background. This lot exhibits a paper residue on the back of the cel. Dimensions: 17" x 13.5" (43.25 cm x 34.5 cm) Sold without copyright; see notice in the Buyer's Guide.

**Estimate: \$1,500 - 3,000**



**712**  
Hand-Drawn The Creep Animation Artwork  
**Creepshow 2 (1986)**

Hand-drawn animation artwork of The Creep from Michael Gornick's horror anthology sequel Creepshow 2. In the animated opening scene, The Creep (Tom Savini) delivered Creepshow comic books to a newsstand in Dexter, Maine. Created for the film's animated sequences by Anivision, LTD, this drawing is rendered in graphite and blue pencil on hole-punched paper hand-numbered "C-25." Also included is a Certificate of Authenticity from animation supervisor Rick Catizone. The paper exhibits creasing and folding to its left corners. Dimensions: 10.5" x 12.5" (26.75 cm x 31.75 cm) Sold without copyright; see notice in the Buyer's Guide.

**Estimate: \$400 - 800**



**708**  
Hand-Painted "The Lonesome Death of Jordy Verrill"  
Alternate Ending Animation Cel  
**Creepshow (1982)**

A hand-painted "The Lonesome Death of Jordy Verrill" alternate ending animation cel from George A. Romero's fantasy-horror film Creepshow. At the end of the segment "The Lonesome Death of Jordy Verrill," Jordy Verrill (Stephen King) shot himself to stop the infectious spread from the meteor. This acetate cel features printed comic book panels with the panels hand-painted in blues, greens, reds, and browns. This lot exhibits a minor tear along the top. Dimensions: 14.5" x 20" (37 cm x 51 cm) Sold without copyright; see notice in the Buyer's Guide.

**Estimate: \$1,500 - 3,000**



**713**  
Hand-Painted Boy Billy (Domenick John)  
Animation Cel with Printed Background  
**Creepshow 2 (1986)**

A hand-painted Boy Billy (Domenick John) animation cel with a printed background from the production of Michael Gornick's horror anthology sequel Creepshow 2. Boy Billy read the Creepshow comics The Creep (Tom Savini) delivered to his newsstand in Dexter, Maine. Created for the animated opening sequence by Anivision, LTD, this lot consists of a mixed media illustration of Billy Boy rendered on acetate, dated "4-30," numbered "23," and affixed to a color-printed red background. Also included is a Certificate of Authenticity from animation supervisor Rick Catizone. The acetate exhibits hole-punching by production. Dimensions: 11" x 17" (28 cm x 43.25 cm) Sold without copyright; see notice in the Buyer's Guide.

**Estimate: \$800 - 1,600**



**715**  
Hand-Drawn Rick Catizone  
The Creep Animation Drawing  
**Creepshow (2019-Present)**

An animation drawing of The Creep hand-drawn by animator Rick Catizone for Greg Nicotero's horror anthology series Creepshow. Catizone's hand-drawings of The Creep were inked, digitally scanned, painted, and composited for animated sequences seen throughout the series and in promotional bumpers. This drawing of The Creep is rendered in graphite on paper hand-numbered "3." The paper is hole-punched and exhibits some bending from production. Dimensions: 10.5" x 12.5" (26.75 cm x 31.75 cm) Sold without copyright; see notice in the Buyer's Guide.

**Estimate: \$400 - 800**



**714**  
Hand-Painted Red Demon Animation Cel  
**Creepshow 2 (1986)**

A hand-painted red demon animation cel from Michael Gornick's horror anthology sequel Creepshow 2. Red demons flew out of the Creepshow comics The Creep (Tom Savini) delivered to a newsstand in Dexter, Maine. Created for the animated opening sequence by Anivision, LTD, this painting of a red horned demon is rendered on acetate, numbered "S.58," labeled "Space," and backed with tissue paper. Also included is a Certificate of Authenticity from animation supervisor Rick Catizone. The acetate is hole-punched and the tissue exhibits tearing and crinkling at the bottom from production. Dimensions: 14" x 17" (35.75 cm x 43.25 cm) Sold without copyright; see notice in the Buyer's Guide.

**Estimate: \$800 - 1,600**



**716**  
Hand-Drawn Rick Catizone  
The Creep Animation Drawing  
**Creepshow (2019-Present)**

An animation drawing of The Creep hand-drawn by animator Rick Catizone for Greg Nicotero's horror anthology series Creepshow. Catizone's hand-drawings of The Creep were inked, digitally scanned, painted, and composited for animated sequences seen throughout the series and in promotional bumpers. This drawing of The Creep is rendered in graphite on paper hand-numbered "7." The paper is hole-punched and exhibits minor edge tears from production. Dimensions: 10.5" x 12.5" (26.75 cm x 31.75 cm) Sold without copyright; see notice in the Buyer's Guide.

**Estimate: \$400 - 800**



**717**  
Frank Ramsey's (Gene Hackman) Naval Officer Jacket  
**Crimson Tide (1995)**

Frank Ramsey's (Gene Hackman) naval officer jacket from Tony Scott's submarine thriller Crimson Tide. Ramsey wore USS naval uniforms as he led his crew in a conflict with Russian separatists who seized control of nuclear weapons. This custom-made black dress uniform jacket by costume designer George L. Little, was ultimately not featured in the film's final cut. It includes four gold-color stripes and a star on each cuff, gold-color painted metal eagle-and-anchor buttons and a "Weston Costume Co." label stitched inside the interior pocket which reads "No. 23826-1, Name Gene Hackman, Chest 47, Sleeve 18." The jacket is accompanied by a Disney Auctions certificate of authenticity.

**Estimate: \$2,000 - 4,000**



**719**  
SkekZok the Ritual Master's  
Decorative Staff Topper Prototype  
**The Dark Crystal (1982)**

SkekZok the Ritual Master's decorative staff topper prototype from Jim Henson's and Frank Oz's fantasy adventure film The Dark Crystal. Ritual Master skekZok features several crescent moon motifs throughout his ensemble. Derived from Brian Froud's concept art but ultimately unused, this topper prototype is painted to resemble gray metal with a green patina, featuring a textured scale-like finish, inlaid red faux crystal eyes, a claw holding a faux indigo translucent faux crystal, and yellow resin talons. It is mounted to a black painted wood base. The topper exhibits light scratching and minor chipping. Dimensions: 4.5" x 3" x 7" (11.5 cm x 7.75 cm x 18 cm)

**Estimate: \$1,500 - 3,000**



**718**  
SkekUng the Garthim-Master's Necklace Prototype  
**The Dark Crystal (1982)**

SkekUng the Garthim-Master's necklace prototype from Jim Henson's and Frank Oz's fantasy adventure The Dark Crystal. SkekUng vied to fill the power-vacuum after Emperor skekSo's death. This necklace features fiberglass and yellow foam, painted gray with a beak-like center element with yellow talons and a faux purple crystal, two attached bone-like pieces and two unattached bone-like pieces with talons. Part of the back side is unfinished and shows exposed yellow foam. The lot exhibits surface cracking and a broken piece of an unattached bone element. Dimensions: (largest) 11.5" x 14" x 3" (29.25 cm x 35.75 cm x 7.75 cm); (smallest): 2" x 1" x 0.5" (5.25 cm x 2.75 cm x 1.5 cm)

**Estimate: \$1,500 - 3,000**



**720**  
SkekUng the Garthim-Master's  
Production-Made Armor and Costume Components  
**The Dark Crystal (1982)**

SkekUng the Garthim-Master's production-made armor and costume components from Jim Henson's and Frank Oz's fantasy adventure The Dark Crystal. SkekUng wore his armor while commanding Garthim forces against the Gelfings. Made of fiberglass and resin, the set includes multi-color plates; a talon and beak; a Skeksis head with green patina; silver- and pewter-color painted simulated metal components and a faux orange crystal. A Polaroid photograph of unpainted and unfinished skekUng costume components is included. The armor and components exhibit wear, paint chipping, adhesive residue, and a missing talon. Dimensions: (largest) 19" x 7" x 7" (48.5 cm x 18 cm x 18 cm)

**Estimate: \$1,500 - 3,000**





**721**  
**SkekTek the Scientist's Brooch**  
**Prototype and Printed Concept Art**  
**The Dark Crystal (1982)**

SkekTek the Scientist's brooch prototype and printed concept art from Jim Henson's and Frank Oz's fantasy adventure *The Dark Crystal*. SkekTek wore different iterations of this brooch as he drained victims of their life essences. This scorpion-shaped resin brooch is painted with a green and copper patina, yellow talons, has an orange faux crystal, and a metal wire at its base. A printed copy of brooch concept sketches is included. The brooch exhibits chipping; the print exhibits folding and edgewear. Dimensions: (print) 16.5" x 12" (42 cm x 20.5 cm); (brooch): 9" x 5.5" x 2.5" (23 cm x 14 cm x 6.5 cm)

**Estimate: \$1,000 - 2,000**



**722**  
**Skeksil the Chamberlain's**  
**Cloak Pin Prototype**  
**The Dark Crystal (1982)**

Skeksil the Chamberlain's cloak pin prototype from Jim Henson's and Frank Oz's fantasy adventure *The Dark Crystal*. Chamberlain wore his cloak pin throughout the film as he schemed to become the Skeksis' Emperor. Created by The Jim Henson Company, this resin pin is hand-painted brown and yellow to resemble stone and bone. It features 10 bone spikes, seven faux rubies inset on the front, and an unfinished back. The lot exhibits missing and chipped pieces, and white staining to the resin from exposure. Dimensions: 4" x 2.25" x 1" (10 cm x 5.75 cm x 2.5 cm)

**Estimate: \$800 - 1,600**



**723**  
**Set of Production and**  
**Promotional Photos and Ephemera**  
**The Dark Crystal (1982)**

A set of production and promotional photos and ephemera from Jim Henson's and Frank Oz's fantasy adventure film *The Dark Crystal*. This lot consists of several portfolios with production photographs and printed copies from various projects, including Skeksis concept sketches by Brian Froud; photographs of printed dragon artwork; various Polaroid photographs; one Christmas card from crew member Dave Barclay featuring Brian Froud artwork; and one press kit with the film's title logo containing cast and crew credits, press releases, and a copy of *Cinefantastique* Volume 13 Number 4. Some of the paper elements exhibit staining, tape residue, and edgewear. Dimensions: (largest) 18" x 13" x 0.5" (45.75 cm x 33.25 cm x 1.5 cm); (smallest): 3.25" x 3.25" (8.25 cm x 8.25 cm)

**Estimate: \$4,000 - 8,000**



**724**  
**Framed Printed Harry Lange**  
**Wall of Destiny Concept Sketch**  
**The Dark Crystal (1982)**

A framed, printed concept sketch of the Wall of Destiny by production designer Harry Lange for Jim Henson and Frank Oz's adventure fantasy *The Dark Crystal*. Jen (Henson) and Kira (Kathryn Mullen) learned the prophecy of a Gelfling's search for a shard of the Dark Crystal from the Wall of Destiny. This production-made copy of Lange's sketch is printed in black-and-white on paper, backed with gray board, and mounted behind glass in a wooden frame. The artwork exhibits tape residue and staining from production. Dimensions: 18" x 24" x 1" (45.75 cm x 61 cm x 2.5 cm) Sold without copyright; see copyright notice in the Buyer's Guide.

**Estimate: \$500 - 1,000**



**725**  
**Mounted Oversize Production**  
**Stills from Marketing Displays**  
**The Dark Crystal (1982)**

Mounted oversize production stills from marketing displays from Jim Henson and Frank Oz's fantasy adventure *The Dark Crystal*. Production stills were created by the marketing team to promote the film's release. This lot consists of 14 colored, oversized production stills on thick cardboard and eight colored standard movie stills. Three of the production stills feature a list of the characters, cast, and crew and an image of the film title in black and white. This lot exhibits minor wear to the corners of the boards. Dimensions: (oversize) 16" x 12" x 0.25" (40.75 cm x 30.5 cm x 0.75 cm); (stills) 10" x 8" (25.5 cm x 20.5 cm)

**Estimate: \$600 - 1,200**



**726**  
**Autographed Dark Crystal**  
**Script and Trailer Video Cassette**  
**with Slipstream Production**  
**Notes and Script**  
**The Dark Crystal (1982)**

An autographed script and trailer video cassette from Jim Henson's fantasy *Dark Crystal*, with production notes and script from Steven Lisberger's sci-fi Slipstream, all used in Craig Miller's public relations work. This lot includes a 75-page, fourth draft *Dark Crystal* script with multicolor revision pages, David Odell's autograph in blue, and a red "G.K. 30" hand-mark; an untested *Dark Crystal* trailer cassette in a brown case; a 121-page Slipstream script with BIMA Productions cardstock pages; and a 79-page Slipstream information packet. The lot exhibits minor creasing, edge wear, and corner wear. Dimensions: 8.5" x 12" x 0.5" (21.75 cm x 30.5 cm x 1.25 cm)

**Estimate: \$400 - 800**



**727**  
Set of Gotham Law Enforcement Badges and Patches  
**The Dark Knight (2008)**

A set of Gotham law enforcement badges and patches from Christopher Nolan's superhero sequel *The Dark Knight*. Various law enforcement appeared throughout the film as they tried to stop Joker (Heath Ledger) from terrorizing Gotham City. This set consists of two iron-on cotton patches labeled "City of Gotham Police Department" and "City of Gotham Correction Department," as well as a plastic-backed resin "City of Gotham Police Department" badge with blue, red, and yellow rank bars painted to appear metallic. Each is applied with a fastening strip on the reverse for affixing to a uniform. The set exhibits minor fraying and paint scuffing from production use.

**Estimate: \$3,000 - 6,000**



**728**  
Joker's (Heath Ledger)  
Sealed Card Deck  
**The Dark Knight (2008)**

Joker's (Heath Ledger) sealed card deck from Christopher Nolan's action thriller sequel *The Dark Knight*. The psychotic Joker planted his customized calling cards throughout the film, including with the car bomb that killed Judge Surillo (Nydia Rodriguez Terracina). This complete, production-made deck of textured semi-gloss Joker cards remains sealed in its original clear plastic wrapping. Each card is printed with a distinct pattern on one side and a malevolent character image, such as gargoyles, dragons, and clowns, on the other. The deck's bottom right corners exhibit some bending from handling. Dimensions: 2.5" x 3.5" x 0.5" (6.5 cm x 9 cm x 1.5 cm)

**Estimate: \$1,000 - 2,000**



**729**  
Set of Gotham Law Enforcement Patches and Badge  
**The Dark Knight (2008)**

A set of Gotham law enforcement Patches and a badge from Christopher Nolan's superhero sequel *The Dark Knight*. Various branches of Gotham City's law enforcement wore their uniforms with accessories throughout the film, including during the Joker's (Heath Ledger) attack on Police Commissioner Loeb's (Colin McFarlane) memorial. This lot consists of two embroidered patches, one "City of Gotham State Courts" and one "SWAT," as well as a black and silver-color resin "City of Gotham Police Department" badge with a black plastic backing and four bars in green, orange, blue, and purple. All three have fastening strip backings. The patches exhibit thread pulling and the badge exhibits some scuffing to the finish. Dimensions: (largest) 5" x 5" x 0.25" (12.75 cm x 12.75 cm x 0.75 cm)

**Estimate: \$3,000 - 6,000**



**730**  
Hand-Painted Juan Ferreyra  
Peacemaker: Disturbing  
the Peace No. 1 Cover Artwork  
**DC Comics**

Artwork hand-painted by comic artist Juan Ferreyra for the cover of *Peacemaker: Disturbing the Peace* issue 1 published by DC Comics in March 2022. The one-shot was written by Garth Ennis with pencils and inks by Garry Brown and colors by Lee Loughridge. This artwork featuring Peacemaker (Christopher Smith) looking at his reflection in a pool of blood is rendered in mixed media on Bristol board. It exhibits some bending along its bottom edge. Dimensions: 17" x 11" (43.25 cm x 30.5 cm) Sold without copyright; see notice in the Buyer's Guide.

**Estimate: \$1,000 - 2,000**



**731**  
Mako Shark Jaws Display  
**Deep Blue Sea (1999)**

A production-made Mako shark jaw display from Renny Harlin's sci-fi action film *Deep Blue Sea*. Production built two smaller sharks known as "G1" which measured about six feet and were also used for the tiger shark seen in the beginning. This lot consists of one set of jaws for an animatronic. These foam jaws feature two rows of sculpted yellow-painted teeth with fleshy pink gums. It also features production-made holes for mounting, and has been mounted onto a black metal armature for display purposes. This lot exhibits cracks, rough edges, notable paint marks, residue, chipped paint, and left over metal rings. Dimensions: 16" x 13" x 15" (40.75 cm x 33 cm x 38 cm)

**Estimate: \$3,000 - 6,000**

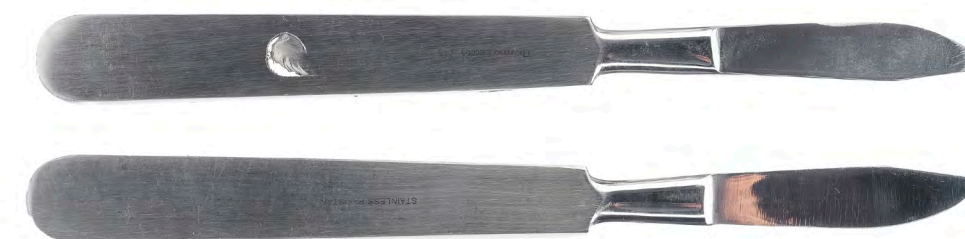

**732**  
Dexter Morgan's  
(Michael C. Hall) SFX Scalpels  
**Dexter (2006-2013)**

A pair of Dexter Morgan's (Michael C. Hall) SFX scalpels from James Manos, Jr.'s crime series *Dexter*. Dexter hunted fellow serial killers throughout the series, including when he tortured Mike Donovan (Jim Abele) with his scalpel in the series' premiere episode "Dexter." This lot comes from the collection of renowned special effects artist Tom "Brooklyn" Bellissimo. It consists of two hollowed stainless steel Thermo Electron 745 surgical scalpels. One scalpel is glued with a plastic SFX blood pipette. Both exhibit scratches and glue residue from production use. Dimensions (scalpel with pipette): 7" x 0.75" x 0.5" (18 cm x 2 cm x 1.5 cm); (scalpel without pipette): 7" x 0.75" x 0.25" (18 cm x 2 cm x 0.75 cm) Blades were dulled by production. This lot comes from the collection of renowned special effects artist Tom "Brooklyn" Bellissimo. A letter of authenticity from Bellissimo is included.

**Estimate: \$1,500 - 3,000**



**733**  
Set of MMPD's Doomsday Killer (Colin Hanks) Evidence  
**Dexter (2006-2013)**

The Miami Metro Police Department's Doomsday Killer (Colin Hanks) evidence from James Manos, Jr.'s crime series Dexter. In the Season 6 episode "A Horse of a Different Color," evidence against the Doomsday Killer was displayed in the MMPD briefing room. This lot consists of an enlarged photocopy of a passage from the Book of Revelation labeled "The Revelation to John" with "Alpha" and "Omega" highlighted by production; a color photograph of a horse painted by the Doomsday Killer; and a printed diagram with the killer's murder methods highlighted in blue marker. The set exhibits tearing and tape residue from hanging. Dimensions: (largest) 38" x 26" (96.5 cm x 66 cm)

**Estimate: \$600 - 1,200**

**734**  
Lon Chaney Jr, Head Cast with Pruneface Prosthetic  
**Dick Tracy Series Pilot (1967)**

A Lon Chaney Jr. head cast with Pruneface prosthetic from William Dozier's unfiled pilot for a live-action adaptation of Dick Tracy. Pruneface did not appear in the pilot, but a make-up test was prepared for a possible future episode with actor Lon Chaney Jr. in the role. This lot consists of a plaster head cast and a face prosthetic. Made of foam and painted in flesh tones, it features a heavily stylized, deeply lined face. It exhibits cracking in the foam, tears around the nose and edges, and cracks in the plaster and chipping. Dimensions: 13" x 10" x 13" (33.25 cm x 25.5 cm x 33.25 cm)

**Estimate: \$1,500 - 3,000**



**737**  
American Bearer Bond  
**Die Hard (1988)**

An American bearer bond from John McTiernan's action thriller Die Hard. Professional thieves led by Hans Gruber (Alan Rickman) posed as terrorists to steal millions of dollars in bearer bonds from the vault in the Nakatomi building. Dated "February 1979," this light green, double-sided \$100,000 bearer bond features black text and a red U.S. Treasury watermark stamp. It exhibits some staining and edge wear from use and age. Dimensions: 15" x 9.5" (38.25 cm x 24.25 cm)

**Estimate: \$2,000 - 4,000**



**738**  
Windsor 114 Airplane Model Miniature  
**Die Hard 2 (1990)**

A Windsor 114 airplane model miniature from Renny Harlin's action sequel Die Hard 2. After hijacking Dulles International Airport, William Stuart (William Sadler) forced Windsor 114 to crash-land, killing everyone aboard. Modeled after a Douglas DC-8-72 passenger jet, this ornately detailed miniature originated from the collection of producer Joel Silver. It is constructed from cast resin, vacuum-formed plastic, and metal hand-painted white with red and blue detailing and silver-color wings. "Windsor" decals are applied to both sides and its underside is taped with wiring. Also included is a Letter of Authenticity from Silver. The wiring was cut following production, and the miniature exhibits some cracking, staining, and flaking paint. Dimensions: 24.5" x 28" x 6" (62.25 cm x 71.25 cm x 15.25 cm) Contains electronics; see electronics notice in the Buyer's Guide.

**Estimate: \$2,500 - 5,000**



**735**  
Stunt Thompson Submachine Gun  
**Dick Tracy (1990)**

A stunt Thompson submachine gun from Warren Beatty's adaptation of Chester Gould's comic strip Dick Tracy. Thompson submachine guns, colloquially known as "Tommy Guns," were used by the eponymous hero (Warren Beatty) and his various criminal nemeses. This dense foam rubber M1928A1 Thompson stunt submachine gun features an attached drum magazine painted brown to resemble wood and cast in black to resemble metal, with manufacturer's engravings throughout. This non-firing gun exhibits minor scratching and uncut flashing at its seamlines. Dimensions: 35" x 6.5" x 7" (89 cm x 16.50 cm x 17.75 cm) Ownership may be restricted in some countries; see replica firearm notice in Buyer's Guide.

**Estimate: \$800 - 1,600**



**736**  
Production-Made Nakatomi  
Plaza Letterhead and Envelope  
**Die Hard (1988)**

Production-made Nakatomi Plaza letterhead and envelope from John McTiernan's action thriller Die Hard. John McClain (Bruce Willis) rescued his wife Holly (Bonnie Bedelia) from terrorist Hans Gruber (Alan Rickman), who held her hostage in Nakatomi Plaza. Created by Earl Hays Press for the production, this lot consists of a sheet of light green letterhead and a matching envelope, both printed with the Nakatomi Plaza logo in burnt umber. The stationery exhibits staining, minor discoloration, edge wear, and curving from storage and age. Dimensions: (largest) 9.5" x 11" (24.25 cm x 28 cm)

**Estimate: \$600 - 1,200**



**739**  
Set of Three Noid Puppet Claymation Heads  
**Domino's Pizza Commercials**

Three Noid Claymation puppet heads from a series of Domino's Pizza commercials. The mischievous Noid sought to sabotage pizzas before they could be delivered to customers and Domino's claimed customers could "Avoid the Noid" by ordering from them. Created by and originating from the collection of Claymation pioneer Will Vinton, each of these peg-registered clay puppet heads is hand-sculpted over a metal armature and hand painted red, white, and black with tan grimacing faces and rabbit-like ears attached via peg holes in the head. This set exhibits cracking clay from age and exposure, and exposed metal pegs beneath the necks for connecting to puppet bodies. Dimensions: (each) 3" x 2.5" x 4" (7.5 cm x 6.5 cm x 15 cm)

**Estimate: \$1,500 - 3,000**



**740**  
Script, Crew Shirts and Paperwork Set  
**Donnie Darko (2001)**

A script, crew shirts, and paperwork from the production of Richard Kelly's sci-fi mystery Donnie Darko. This set, collected during production by sound mixer Coleman Metts, consists of a 105-page yellow revision shooting script dated "June 27, 2000" and hand-marked "Coleman" along the bottom; two gray crew T-shirts; 270 pages of various paperwork, some of which is hand-annotated; a disk labeled "Donnie Darko trks 1-21" with a color image of Coleman's equipment; and color photographs of Metts with various key cast and crew members, including Kelly, Jake and Maggie Gyllenhaal, Drew Barrymore, Patrick Swayze, Jena Malone, Mary McDonnell, Holmes Osborne, and Noah Wyle. This lot exhibits tears in the paperwork from use. Dimensions: 8.5" x 14" x 0.5" (21.75 cm x 35.75 cm x 1.75 cm)

**Estimate: \$2,000 - 4,000**



**741**  
Goat's (Ben Daniels) Light-Up Shotgun  
**Doom (2005)**

Goat's (Ben Daniels) light-up shotgun from Andrzej Bartkowiak's action film *Doom*. Goat carried and used his shotgun until his death. This lot consists of one static shotgun designed from a shortened pump-action Benelli M3 Super 90. This black rubber shotgun is fitted with a light-up aluminum shroud, which features a green side panel that illuminates when activated via a switch on the opposite side. The panel reads "RNDS 065, Goat, 2/396" but is faint due to age. Attached is a non-functional scope and a flashlight beneath the barrel. Included is a hard plastic case. Production intentionally distressed this shotgun for a battle-worn appearance. This lot exhibits a cracked lens, notable residue, chipped and flaking paint, and pitting to the rubber. Dimensions: 23.5" x 10" x 2.5" (59.75 cm x 25.5 cm x 6.5 cm) Ownership may be restricted in some countries; see replica firearm notice in Buyer's Guide. Contains electronics; see electronics notice in the Buyer's Guide.

**Estimate: \$3,000 - 6,000**



**742**  
Hand-drawn Storyboards  
**Dragon: The Bruce Lee Story (1993)**

Storyboards from the production of Rob Cohen's biographical drama *Dragon: The Bruce Lee Story*. They depict a deleted sequence where Bruce Lee (Jason Scott Lee) was transported from his Oakland, CA studio to a wasteland where he encountered the Demon (Sven-Ole Thorsen). The 21 storyboards are drawn on hole-punched A4 paper and appended with sheets of tracing paper. Each storyboard features handwritten scene notes. Most are rendered in charcoal or pencil, but five feature color detailing. The lot exhibits minor edge wear and staining from production use. Dimensions: 11" x 8.75" x 0.25" (28 cm x 22 cm x 0.5 cm) Sold without copyright; see copyright notice in the Buyer's Guide.

**Estimate: \$1,000 - 2,000**



**743**  
Deena Jones (Beyonce Knowles), Effie White (Jennifer Hudson), and Lorrell Robinson's (Anika Noni Rose) Great Wall Costumes  
**Dreamgirls (2006)**

Deena Jones (Beyonce Knowles), Effie White (Jennifer Hudson), and Lorrell Robinson's (Anika Noni Rose) Great Wall costumes from Bill Condon's musical drama *Dreamgirls*. The *Dreamgirls* wore their costumes while visiting the Great Wall. This lot consists of a pink and yellow polyester Cheongsam dress (40); a blue and gold floral dress (XXL); a purple and gold rayon Peony Brand dress (38); a pair of leatherette sandals; a red-painted wood and cloth hand fan; three black-painted wood and cloth hand fans; two pairs of earrings; and four production tags. This lot exhibits loose threads and scuffs on the sandals. Dimensions: (fan) 16.5" x 9" x 1" (42 cm x 23 cm x 2.75 cm)

**Estimate: \$1,500 - 3,000**



**744**  
Gurney Halleck's (P.H. Moriarty) Dagger and Sheath  
**Dune (2000)**

Gurney Halleck's (P.H. Moriarty) dagger and sheath from the sci-fi mini-series *Frank Herbert's Dune*. Gurney carried and used his dagger throughout the film. This lot consists of a crescent-shaped dagger and sheath. It is constructed of a silver-color metal sheet with a wooden handle that features an inlaid metal embellishment on one side of the handle. It comes with a brown leather sheath that features a belt loop. This lot exhibits scratches on both the leather and dagger, as well as discoloration and some residue. Dimensions: 16" x 3" x 2" (40.75 cm x 7.75 cm x 5.25 cm) Blade was dulled by production.

**Estimate: \$700 - 1,400**



**745**  
Duncan Idaho's (Edward Atterton) Atreides-Style Retractable Dagger and Sheath  
**Frank Herbert's Children Of Dune (2003)**

Duncan Idaho's (Edward Atterton) Atreides-style retractable dagger and sheath from the sci-fi mini-series *Frank Herbert's Children of Dune*. The cloned Idaho carried and used his dagger throughout the film. This lot consists of a stunt dagger and sheath. This polished sheet metal dagger features a retractable blade, a wood handle, and a brass-color metal handguard and round pommel. The sheath features a belt loop, a silver-color metal embellishment and silver-color metal tip. This lot exhibits a loose tip on the sheath, pitting in the metal, discoloration, and scratches. Dimensions: 14" x 3.5" x 1" (35.75 cm x 9 cm x 2.75 cm) Blade was dulled by production.

**Estimate: \$500 - 1,000**

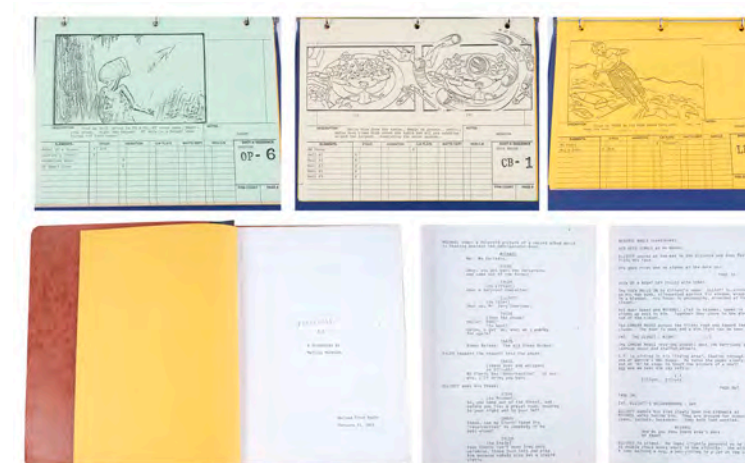

**746**  
Industrial Light & Magic (ILM) VFX Storyboard Set and Screenplay  
**E.T. The Extra-Terrestrial (1982)**

Industrial Light & Magic (ILM) VFX storyboards and a screenplay from Steven Spielberg's sci-fi classic *E.T. the Extra-Terrestrial*. Young suburban boy Elliott (Henry Thomas) befriended an alien marooned on Earth during an exploratory mission. This lot consists of a blue binder marked "E.T. ILM STORYBOARDS NO.4" containing 35 printed storyboards for several VFX sequences, and a brown folder-bound, 122-page copy of the revised first draft of Melissa Mathison's screenplay. The screenplay is dated February 11, 1981 with each page labeled "ETME 10041." The lot exhibits signs of wear from age and use. Dimensions: 12" x 10" x 1.75" (30.5 cm x 25.5 cm x 4.5 cm)

**Estimate: \$1,200 - 2,400**

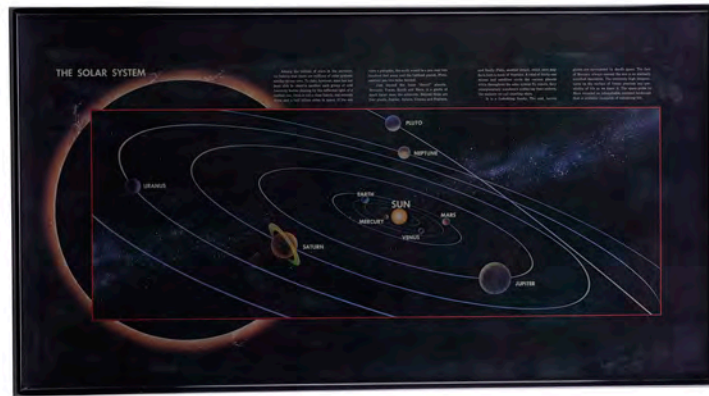

**747**  
 Elliott's (Henry Thomas) Framed  
 Production-Made Solar System Poster  
**E.T. The Extra-Terrestrial (1982)**

Elliott's (Henry Thomas) framed production-made solar system poster from the production of Steven Spielberg's sci-fi classic E.T. the Extra-Terrestrial. Elliott used a diagram of the solar system to help E.T. understand where in the universe he was stranded. Color-printed for the production by Earl Hays Press, this poster is labeled "The Solar System" with illustrations of the sun and its orbiting planets against a night sky. It comes mounted behind glass in a black plastic frame. The poster exhibits creases and fold lines from being closed and opened by production. Dimensions: 16" x 29.5" x 0.5" (40.75 cm x 75 cm x 1.5 cm)

**Estimate: \$1,200 - 2,400**



**748**  
 Replica Crockpot Monster  
**Elvira: Mistress Of The Dark (1988)**

A replica crockpot monster from James Signorelli's comedy horror Elvira: Mistress of the Dark. Elvira (Cassandra Peterson) made Bob Redding (Daniel Greene) a home-cooked dinner, but summoned a monster by accident that lunged at them from the crockpot. This lot consists of a replica monster cast of the puppet from Doug Beswick's original molds. Made of foam painted in shades of yellow and brown, this iguana-like monster features resin teeth and plastic spikes. It comes on a black-painted wooden display. This lot exhibits imperfections from the mold such as pitting and bumps. Dimensions: 17" x 12" x 22" (43.25 cm x 30.5 cm x 56 cm)

**Estimate: \$1,500 - 3,000**



**749**  
 Set of Aladdin and International  
 Casino Chips with International Ashtray  
**Elvis (2022)**

A set of Aladdin and International Casino poker chips with an International Ashtray from Baz Luhrmann's biographical drama Elvis. Colonel Tom Parker (Tom Hanks) accrued debt through gambling and then used Elvis Presley (Austin Butler) to alleviate it. This collection consists of 39 Aladdin chips, 29 International chips, and one black glass ashtray. These production-made chips feature the Aladdin and International Casino logos and range in denomination from \$1 up to \$1,000. This lot exhibits mild chipping and imperfections from production. Dimensions: 4.5" x 4.5" x 1.25" (11.5 cm x 11.5 cm x 3.25 cm)

**Estimate: \$600 - 1,200**



**750**  
 Jericho Cane's (Arnold  
 Schwarzenegger) Leather  
 Jacket Costume  
**End Of Days (1999)**

Jericho Cane's (Arnold Schwarzenegger) leather jacket costume from Peter Hyams' action horror film End of Days. Cane rescued Christine York (Robin Tunney) from attackers who wanted to kill her to prevent Satan (Gabriel Byrne) from conceiving the Antichrist. This ensemble consists of one black leather button-down, satin-lined jacket; one charcoal cotton sweater with intentionally shortened sleeves; one charcoal cotton long-sleeve sweater; dark green cotton cargo trousers (size 36/34); and one black leather belt (size 40). The lot exhibits piling, scuffing, leather cracking, frayed ends, and discoloration; the sweater exhibits chest holes.

**Estimate: \$2,500 - 5,000**



**751**  
 The Man/Satan's  
 (Gabriel Byrne) Costume  
**End Of Days (1999)**

The Man/Satan's (Gabriel Byrne) costume from Peter Hyams' action horror film End of Days. Satan possessed an unnamed banker (Byrne) in his pursuit of Christine York (Robin Tunney), to bring about the apocalypse. The lot consists of a black wool blazer, hand-marked "EC.C" in white on inside of inner liner pocket; a black rayon button-down shirt (size 16); black wool crepe trousers, hand-marked "#1" on the interior waistband; and a pair of black leather oxford dress shoes. The lot exhibits a broken button on the trousers and scuffing on the shoes along with dirtied soles.

**Estimate: \$1,200 - 2,400**



**752**  
 1982 Favorite New  
 Song People's Choice Award  
**Endless Love (1981)**

A People's Choice Award for Favorite New Song awarded to Lionel Richie's theme song "Endless Love" from Franco Zeffirelli's romantic drama Endless Love. The award was given at the 8th annual ceremony held March 18, 1992. This glass award is sculpted by Orrefors of Sweden with an image of hands clapping within a flame etched into the teardrop-shaped center and "The People's Choice Award 1982 ENDLESS LOVE Favorite New Song" etched into the square base. Four clear rubber covers are applied to the bottom. The award exhibits fingerprints and minor scratches throughout from handling. Dimensions: 5" x 4" x 14" (12.75 cm x 10.25 cm x 35.75 cm)

**Estimate: \$1,000 - 2,000**

48.5" (123.25 cm)



**753**  
Full-Size Light-Up Screen-Matched County General Hospital Emergency Room Sign  
ER (1994-2009)

A full-size, light-up screen-matched County General Hospital emergency room sign from Michael Crichton's medical drama series ER. County's staff and visitors passed by its exterior sign throughout the series, including the finale episode, to which grime and streaking on this sign screen-match. This wooden sign features four paper-covered blue and red plastic panels reading, from top down, "County General Hospital," "Emergency," "Main Entrance," and "Visitor Parking." AC power cords set into the reverse illuminates it. The sign exhibits extensive griminess from years of production use and exposure, and panel warping at the bottom and center. Dimensions: 48.5" x 72" x 12" (123.25 cm x 183 cm x 30.5 cm) Special shipping required; see notice in the Buyer's Guide. Contains electronic components; see notice in the Buyer's Guide.

**Estimate: \$1,500 - 3,000**

**754**  
Snake Plissken's (Kurt Russell) Costume  
Escape From L.A. (1996)

Snake Plissken's (Kurt Russell) costume from John Carpenter's action sequel Escape from L.A. Plissken wore his costume while traversing the perilous island that was once Los Angeles on a mission forced onto him by the United States government. This lot consists of a gray synthetic-blend sleeveless top with a black mesh overlay and sewn-in leotard to keep it tucked, and a matching pair of trousers with boot stirrups and fastening strip segments around the waist and thighs. Both elements are hand-marked "Kurt Hero" with the top additionally hand-marked "1/16/96." The lot exhibits some wear from use and age, including shoulder seams loosening and fading of the markings.

**Estimate: \$2,000 - 4,000**

**755**  
Ted Pikul's (Jude Law) Gristle Gun  
Existenz (1999)

Ted Pikul's (Jude Law) gristle gun from David Cronenberg's sci-fi thriller eXistenZ. A dog chewed the gun with which Ted shot his waiter in a Chinese restaurant. This otherworldly, custom-made resin gun was molded and affixed with latex detailing by special effects supervisor Bob Hall. It is hand-painted yellow, red, and white to resemble bits of skin, teeth, and gristle with a boney trigger jutting from the handle. Also included is a Certificate of Authenticity signed by Hall. The gun exhibits flaking latex and some chipping from production use and age. Dimensions: 8" x 4" x 3" (20.5 cm x 10.25 cm x 7.75 cm)

**Estimate: \$2,000 - 4,000**



**756**  
Toll Road's (Randy Couture) Stunt Heckler & Koch MP5K  
The Expendables (2010)

Toll Road's (Randy Couture) stunt Heckler & Koch MP5K from Sylvester Stallone's action film The Expendables. Toll Road wielded his Heckler & Koch MP5K when the Expendables recovered a besieged oil tanker. This dense rubber stunt submachine gun is painted black and silver-color with manufacturer labels throughout the body, a static flashlight attachment, a molded rubber Blast 2 laser sight attachment, and metal hook embedded on the back and side for a securing strap. The rubber exhibits some nicks from production. Dimensions: 13" x 11.5" x 4" (33 cm x 29.25 cm x 10.25 cm) Ownership may be restricted in some countries; see replica firearm notice in Buyer's Guide.

**Estimate: \$1,500 - 3,000**

**758**  
Prison Officer Jumpsuit  
Face/Off (1997)

A prison officer jumpsuit from John Woo's action thriller Face/Off. Officers wore jumpsuits as part of the uniform within the high-security prison, Erewhon, where Sean Archer (John Travolta) posed as Castor Troy to obtain information on the "Sinclair" bomb from Pollux Troy (Alessandro Nivola). The dark gray polycotton jumpsuit features an "Erewhon P4 Storage Facility" embroidered patch on each shoulder and an elasticated waist. A zipper runs down the front, and the costume is marked as a size 46. The lot exhibits several minor marks and some scuffing on the left leg.

**Estimate: \$800 - 1,600**



**757**  
Susie Diamond's (Michelle Pfeiffer) Shoes with Fabulous Baker Boys Business Card  
The Fabulous Baker Boys (1989)

Susie Diamond's (Michelle Pfeiffer) shoes with a Fabulous Baker Boys business card from Steve Kloves' musical drama The Fabulous Baker Boys. Diamond wore her pumps while singing "Makin' Whoopee" with Jack Baker (Jeff Bridges), who made new business cards with his brother Frank (Beau Bridges) to promote their growing musical act. This lot consists of two ruby-color high-heel pumps with leatherette insoles hand-marked "F6" and "P6," as well as an off-white production-made business card labeled "The Fabulous Baker Boys," "Jack Baker," and "Frank Baker" in blue. The shoes exhibit tearing and staining on their interiors from production wear. Dimensions: (card) 2.5" x 3.5" (6.5 cm x 9 cm)

**Estimate: \$600 - 1,200**

49.5" (125.75 cm)

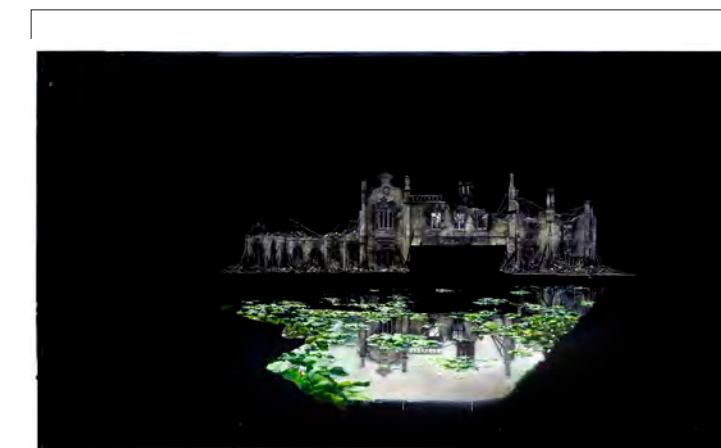

**759**  
Hand-Painted Michael Pangrazio Burned Mansion and Pool Matte Painting  
Far And Away (1992)

A hand-painted Michael Pangrazio burned mansion and pool matte painting from Ron Howard's epic western romance Far and Away. After the Christie's home was set ablaze, they decided to look for their daughter, Shannon (Nicole Kidman), in Boston. This lot consists of one oversize matte painting on a framed glass panel. It features a hand-painted image of remnants of a burned building and a pool of water with lily pads on a solid matte-black background. The back of the painting was painted white by production. This lot exhibits chipped paint, and scratches. Dimensions: 49.5" x 84" x 0.5" (125.75 cm x 213.5 cm x 2.5 cm) Sold without copyright; see copyright notice in the Buyer's Guide. Special shipping required; see notice in the Buyer's Guide.

**Estimate: \$2,000 - 4,000**



**760**  
**Unfinished Stunt Mangalore Rifle**  
**The Fifth Element (1997)**

An unfinished stunt Mangalore rifle from Luc Besson's sci-fi adventure The Fifth Element. Hired by Zorg (Gary Oldman), alien Mangalores wielded rifles throughout the film as they pursued Leeloo (Milla Jovovich) and Korben Dallas (Bruce Willis) in search of the Mondoshawan elemental stones. Custom-made for the production, this unfinished stunt rifle is constructed of dense rubber painted completely black with ribbed detailing along the sides and rail detailing along the stock and barrel. The weapon exhibits splitting on the barrel and grip from age, as well as grime throughout from exposure. Dimensions: 32" x 11.25" x 3" (81.5 cm x 28.75 cm x 7.75 cm)

**Estimate: \$3,000 - 6,000**



**761**  
**Zaltman G. Bleros Multi Pass**  
**The Fifth Element (1997)**

A Zaltman G. Bleros Multi Pass from Luc Besson's sci-fi adventure The Fifth Element. Multi Passes served as IDs in the film. Though he did not ultimately appear on screen, "Zaltman Bleros" was Besson's original name for Korben Dallas (Bruce Willis). This plastic Multi Pass features two photographs of creature design supervisor Nick Dudman with personal information, including his name, address, blood type, and height, printed in color on the front. "Class T" and four empty rows are printed on the reverse. It exhibits minor staining throughout and uneven edges from production. Dimensions: 3" x 2.25" x 0.25" (7.75 cm x 5.75 cm x 0.75 cm)

**Estimate: \$1,200 - 2,400**



**762**  
**Pair of Tyler Durden's**  
**(Brad Pitt) Boarding Passes**  
**Fight Club (1999)**

A pair of Tyler Durden's (Brad Pitt) boarding passes from David Fincher's comedic drama Fight Club. The Narrator stumbled across multiple boarding passes while rummaging through Durden's belongings. This lot consists of two custom-made, serrated boarding passes, one for an "Access Airlines" flight from "Bradford" to "Phoenix" and one for an "Escort Air" flight from "Bradford" to "Salt Lake City." Both are made out to "Durden/Tyler" and feature matching document numbers "00051331653891." The Salt Lake City pass features grime on the end stub from production. Dimensions (each): 8" x 3" (20.5 cm x 7.75 cm)

**Estimate: \$1,200 - 2,400**



**763**  
**Set of Three Paper**  
**Street Soap Company Wrappers**  
**Fight Club (1999)**

Three Paper Street Soap Company wrappers from David Fincher's comedic thriller Fight Club. Project Mayhem leader Tyler Durden (Brad Pitt) made and sold soap in the kitchen of his dilapidated house on Paper Street using fat stolen from liposuction clinics. This set consists of three different double-sided Paper Street Soap Co. wrappers for the "Oatmeal with Milk and Honey," "Oatmeal and Vanilla Bean," and "Mixed Herb and Tea Tree Oil" flavors printed with black text and logos on gray, tan, and brown textured cardstock. They are unfolded and exhibit minor staining and bending from production. Dimensions: (each) 7.5" x 3" (19 cm x 7.75 cm)

**Estimate: \$1,000 - 2,000**



**764**  
**Sir James Matthew Barrie's**  
**(Johnny Depp) Sword**  
**Finding Neverland (2004)**

Sir James Matthew Barrie's (Johnny Depp) sword from Marc Forster's biographical drama Finding Neverland. Barrie wielded his sword as he played pirates with the Llewelyn Davies family. This lot consists of one polyurethane sword. Designed after a cutlass, this sword features a rigid decorative handguard painted antique gold-color and an engraved hilt painted brown. It features an engraved decorative langet. The blade is painted dark gray with silver-color highlights to give the appearance of a metal blade. This sword exhibits cracking in the finish of the blade, notable knicks and lines, and notable paint marks. Dimensions: 37" x 6" x 5" (100 cm x 15.25 cm x 12.75 cm)

**Estimate: \$3,000 - 6,000**



**765**  
**Peter Davies' (Freddie Highmore)**  
**Fantasy Sequence Pirate Scarf**  
**Finding Neverland (2004)**

Peter Davies' (Freddie Highmore) fantasy sequence pirate scarf from Marc Forster's biographical drama Finding Neverland. Peter wore his scarf while he and his brothers played pirates with Sir James Matthew Barrie's (Johnny Depp). This lot consists of one blue cotton square scarf with unfinished edges. The scarf features a repeating pattern of light blue six-point stars. This scarf exhibits fading and discoloration.

**Estimate: \$400 - 800**



**766**  
**Forrest Gump's**  
**(Tom Hanks) Feather**  
**Forrest Gump (1994)**

Forrest Gump's (Tom Hanks) feather from Robert Zemeckis' historical drama Forrest Gump. During the film's opening scene, a feather fell at Forrest's feet before he picked it up and placed it inside a book. Though a computer-animated feather was created for shots showing motion, a real one was used for Hanks to interact with. This is a production feather, but does not match the one Forrest held in close up. This feather features a white rachis, fluffy white downy lower barbs, and gray-striped barbs near the tip. It exhibits a bit of bending to the middle barbs and pulling to the downy barbs. Dimensions: 4" x 2.5" x 0.25" (10.25 cm x 6.5 cm x 0.75 cm)

**Estimate: \$1,200 - 2,400**



**767**  
**Forrest Gump's**  
**(Tom Hanks) Hospital Robe**  
**Forrest Gump (1994)**

Forrest Gump's (Tom Hanks) hospital robe from Robert Zemeckis' historical drama Forrest Gump. Gump wore his robe while recovering in the army hospital after being shot in the buttocks in Vietnam. This blue corduroy collared button-up military bathrobe (size S) features three front pockets, with the top left pocket embroidered in white with a Caduceus symbol and "US" logo. It exhibits some wear from use and age, including a bit of discoloration.

**Estimate: \$3,500 - 7,000**

**768**  
**Binder of Production**  
**Ephemera Featuring**  
**Vietnam Battle Storyboards**  
**Forrest Gump (1994)**

A binder of production ephemera featuring Vietnam battle storyboards from Robert Zemeckis' historical drama Forrest Gump. Gump (Tom Hanks) saved Lt. Dan Taylor (Gary Sinise) during a Vietnamese ambush. This lot contains a blue-green nylon binder with approximately 300 pages, including pager lists, script pages, schedule memoranda, and staff and crew listings; 54-page bound storyboard copies of the Vietnam battle segment; 77 bound pages of green revisions prefaced by memoranda; and 14 salmon color third draft script pages. The lot exhibits grime, edge wear, creasing, bent corners, and liquid damage. Dimensions: 11" x 12" x 4.5" (28 cm x 30.5 cm x 11.5 cm)

**Estimate: \$1,000 - 2,000**

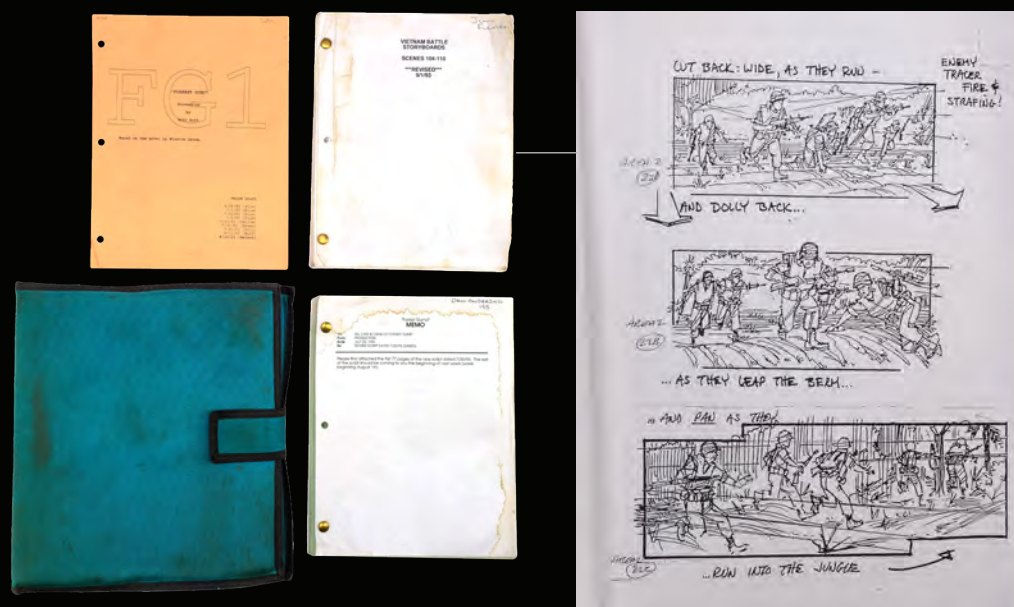

**769**  
**Mary "Mame" Carson's**  
**(Jane Russell) Leotard**  
**The French Line (1953)**

Mary "Mame" Carson's (Jane Russell) leotard from Lloyd Bacon's musical-romance film The French Line. Carson wore her leotard during her dinner performance aboard The French Line. Designed by Michael Wolfe, this red leotard features red sequins, a red tulle trim, black metal studs, clear acrylic rhinestones, boning, and a zipper closure. Included are three exhibition booklets in English and French; one 18-page booklet from The Costume Institute, one 48-page booklet from the Whitworth Gallery at the University of Manchester, and one 15-page booklet from Hollywood Au Marais. This leotard exhibits loose threads, discolored rhinestones, tape residue, and a torn groin.

**Estimate: \$1,000 - 2,000**

**770**  
**Mario Kirner Collection:**  
**First Draft Script**  
**Friday The 13th Part VI:**  
**Jason Lives (1986)**

A first draft script from the production of Tom McLoughlin's slasher sequel Friday the 13th Part VI: Jason Lives. The script originally belonged to special effects artist William Forsche. It is credited to McLoughlin, is 107 pages long, coincidentally dated "Fri. 13th Dec. 1985" and bound with three brass butterfly pins. The cover page features the film's working title "Jason Has Risen". The script has wear from production use including minor staining. Dimensions: 11" x 8.75" x 0.5" (28 cm x 22 cm x 1 cm) Additional Provenance: This lot comes from the personal collection of Friday the 13th collector and historian Mario Kirner.

**Estimate: \$700 - 1,400**

**771**  
**Mario Kirner Collection:**  
**Kane Hodder's Personal Script**  
**Friday The 13th Part VII:**  
**The New Blood (1988)**

Kane Hodder's personal script from the production of John Carl Buechler's slasher sequel Friday the 13th Part VII: The New Blood, in which Hodder starred as Jason Voorhees. This lot comes from the personal collection of Friday the 13th collector and historian Mario Kirner. Bound by brass fasteners, the 91-page script is dated "November 25, 1987" and the text "Friday 13th - VII, rev. 11/25/87" is printed along the top of each page. Hodder highlighted sections of the text in yellow referring to Jason, and "Friday VII, 11/25" is written along the spine. The date on the cover is underlined in red pen and some page corners exhibit folding over time from use. Dimensions: 11" x 8.5" x 0.5" (28 cm x 21.5 cm x 1.5 cm)

**Estimate: \$2,000 - 4,000**

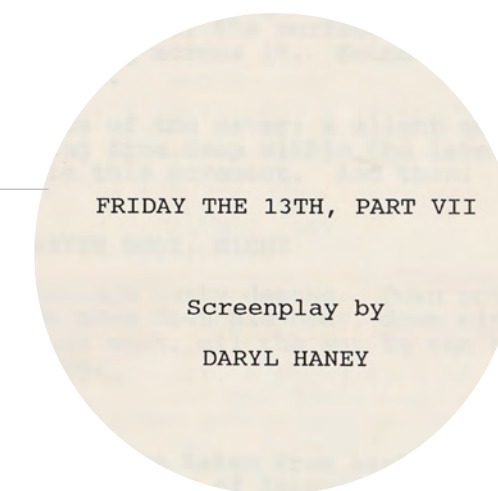
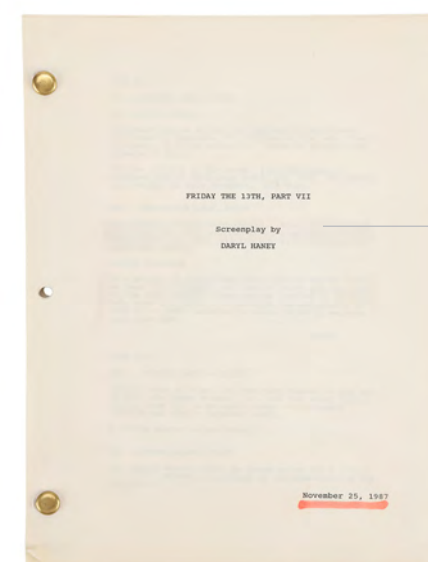
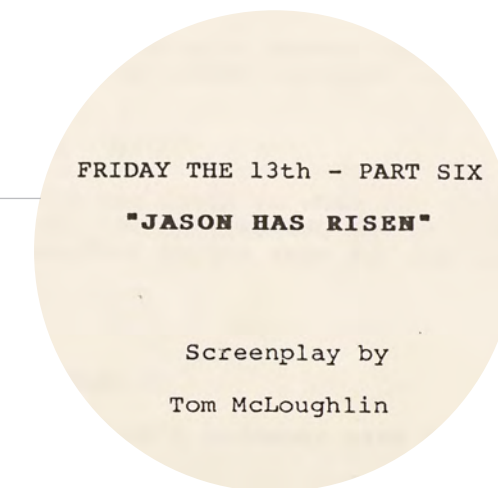





**772**  
**Mario Kirner Collection: Hero Kitchen Knife**  
**Friday The 13th Part VII: The New Blood (1988)**

A hero kitchen knife from John Carl Buechler's slasher sequel Friday the 13th Part VII: The New Blood. This lot comes from the personal collection of Friday the 13th collector and historian Mario Kirner. When David (Jon Renfield) rummaged through the cabin's refrigerator, a lightning flash illuminated Jason (Kane Hodder) holding a large kitchen knife. It was also used in the production of Dwight H. Little's Halloween 4: The Return of Michael Myers, which was filmed the same year and used the same effects company, Magical Media Industries. Four knives were made for production: a hero blade, a stunt version, and a set of retractable ones. This hero knife features a blunted silver-painted metal blade and a wooden handle engraved "44S CHICAGO CUTLERY." Its chrome-color blade was painted silver to be more visually striking on camera. The blade exhibits scuffs and scratches from production use revealing the chrome finish beneath. It comes with a letter of authenticity from the prop master Batia Grafka. Dimensions: 15.2" x 0.08" x 2.2" (38.5 cm x 2 cm x 5.5 cm)

**Estimate: \$2,000 - 4,000**

**774**  
**Julius Graw's**  
**(V.C. Dupree) Severed**  
**SFX Close-Up Head**  
**Friday The 13th**  
**Part VIII: Jason Takes**  
**Manhattan (1989)**



Julius Graw's (V.C. Dupree) severed SFX close-up head from Rob Hedden's slasher sequel Friday the 13th Part VIII: Jason Takes Manhattan. Julius fought Jason (Kane Hodder) before Jason punched his head clean off. Originating from a source close to production, this lot consists of one highly detailed severed head. Composed of a hardcast foam painted to resemble skin, this head features hand-glued crepe wool hair, a protruding inner rubber tube from the neck, and detailed sculpted neck viscera. Included is a 5" x 7" (12.75 cm x 18 cm) photo of SFX director Jamie Brown holding the head with actress Barbara Bingham. This lot exhibits foam cracking, chipping, and notable residue. Dimensions: 13" x 9" x 7" (33 cm x 23 cm x 18 cm)

**Estimate: \$1,200 - 2,400**

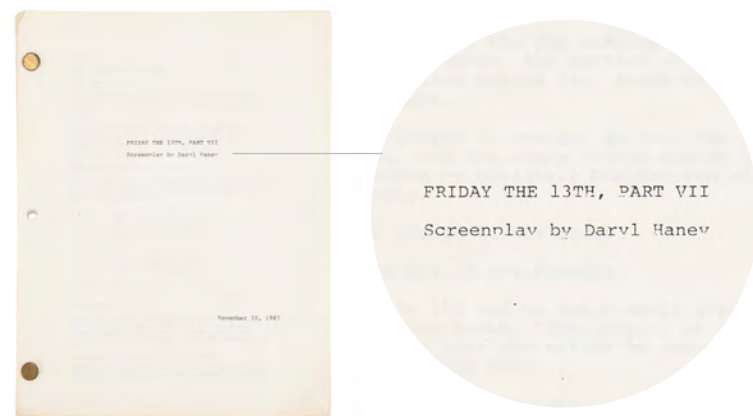

**773**  
**Mario Kirner Collection: Production-used Script**  
**Friday The 13th Part VII: The New Blood (1988)**

A production-used script from John Carl Buechler's slasher sequel Friday the 13th Part VII: The New Blood. This lot comes from the personal collection of Friday the 13th collector and historian Mario Kirner. The script - credited to Daryl Haney - is 91 pages long, held together with two brass butterfly fasteners, and dated "November 20, 1987." Each page has the header "partial revision 20/11/87." Page 54 has a line of dialogue circled and crossed out, and page 5 has "I don't want too [sic]" handwritten in the margin. Dimensions: 11" x 8.75" x 0.75" (28 cm x 22 cm x 2 cm)

**Estimate: \$800 - 1,600**

**775**  
**V.C. Dupree's**  
**Crew Jacket with**  
**Cast- and Crew-**  
**Autographed**  
**Annotated Script**  
**Friday The 13th**  
**Part VIII: Jason Takes**  
**Manhattan (1989)**



V.C. Dupree's crew jacket with cast- and crew-autographed annotated script from Rob Hedden's slasher sequel Friday the 13th Part VIII: Jason Takes Manhattan. Originating from a source close to production, the black wool and satin letterman-style jacket features embroidered patches and a plastic hockey mask pin. The 121-page script is bound by a blue three-ring binder with "VC" in the bottom right corner and is hand-annotated throughout. Included are 43 pages of production paperwork, some autographed by cast and crew. This lot exhibits fragility on the tag, discoloration, and ripped paper. Dimensions: (script) 11.5" x 10" x 2" (29 cm x 25 cm x 5 cm)

**Estimate: \$1,000 - 2,000**



**776**  
**Mario Kirner Collection: Crew Sweater**  
**Friday The 13th Part VIII: Jason Takes Manhattan**  
**(1989)**

A crew sweater from the production of Rob Hedden's slasher sequel Friday the 13th Part VIII: Jason Takes Manhattan. The black sweatshirt (size "L") features a printed image of a hockey mask and Manhattan's cityscape above the film's title with a red "Vancouver" cancel stamp across the word Manhattan. Custom crew sweaters like these were made for the crew due to the production mostly being filmed in Vancouver. Also included is a behind-the-scenes photograph and a letter of authenticity from a crew member who was gifted the sweater at the end of production. The sweatshirt exhibits fading and shrinkage from age and use.

**Estimate: \$300 - 600**

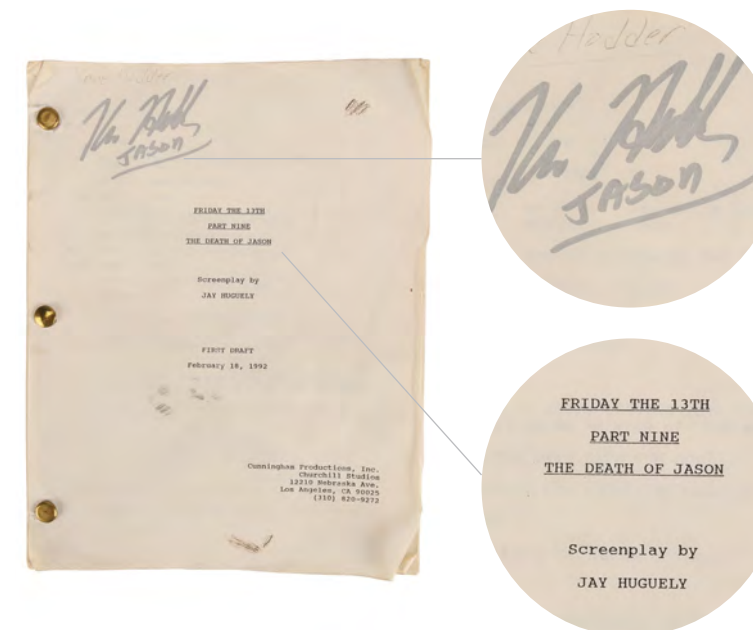

**777**  
**Mario Kirner Collection: Kane Hodder's Heavily**  
**Annotated and Autographed Personal Script**  
**Jason Goes To Hell: The Final Friday (1993)**

Kane Hodder's personal script from the production of Adam Marcus' horror sequel Jason Goes to Hell: The Final Friday. This lot comes from the personal collection of Friday the 13th collector and historian Mario Kirner. Hodder played the iconic villain Jason Voorhees in four films in the series, and was also the stunt coordinator on the film. The 90-page script - which is credited to Jay Huguely - is a first draft dated "February 18, 1992." It also features the film's original title "Friday the 13th - Part Nine - The Death of Jason." Hodder's name is written on the cover page alongside his autograph in silver-color ink. The script is heavily annotated, with notes on which scenes required stunt doubles and the final few pages are covered with production notes, including the sizes of and various phone numbers for stunt performers on the final page. Some pages exhibit tears and minor staining. Dimensions: 11" x 8.75" x 0.75" (28 cm x 22 cm x 1.5 cm)

**Estimate: \$3,000 - 6,000**

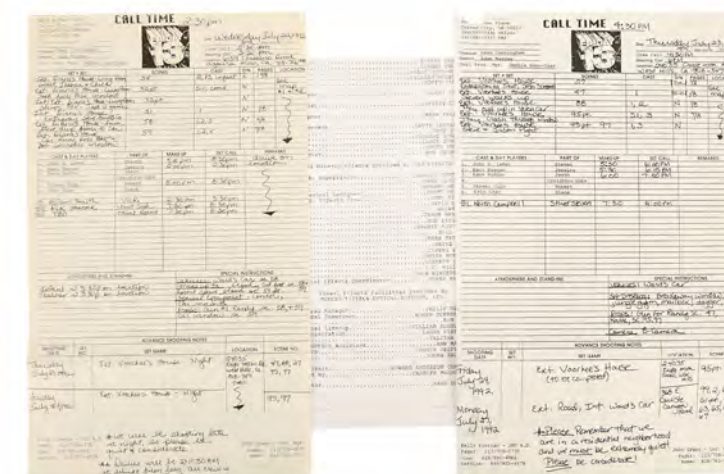

**778**  
**Mario Kirner Collection:**  
**Handwritten and Printed Call Sheets**  
**Jason Goes To Hell: The Final Friday (1993)**

A pair of call sheets from the production of Adam Marcus' slasher sequel Jason Goes to Hell: The Final Friday. This pair includes a handwritten "master" call sheet dated "Wednesday July 22, 1992" and a printed copy dated "Thursday July 23, 1992". The master copy would have been photocopied and distributed to the crew and actors. Both call sheets feature the original Friday the 13th film logo, in honour of the film's producer Sean Cunningham. Also in the lot is a printed page featuring a partial crew list, including Kane Hodder as the stunt coordinator. Dimensions: 10.5" x 6.75" (27 cm x 21.5 cm) Additional Provenance: This lot comes from the personal collection of Friday the 13th collector and historian Mario Kirner.

**Estimate: \$500 - 1,000**

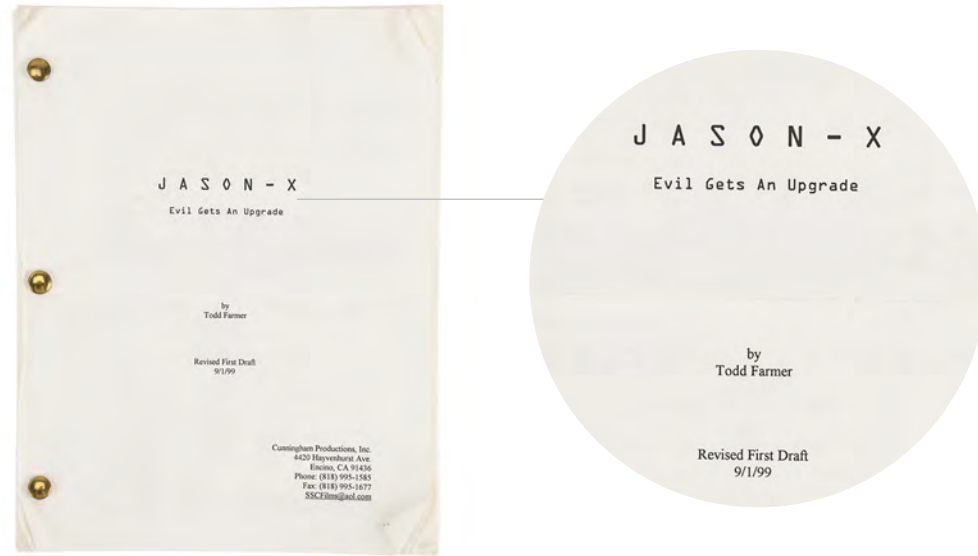

**779**  
 Mario Kirner Collection: Kane Hodder's Personal Highlighted First Draft Script  
**Jason X (2001)**

Kane Hodder's personal highlighted first draft script from the production of Jim Isaac's horror sequel Jason X. This lot comes from the personal collection of Friday the 13th collector and historian Mario Kirner. Hodder played the iconic villain Jason Voorhees in four films in the series. This early version of the script - which is credited to Todd Farmer - is 113 pages long and is held together with brass fasteners. Jason's directions are highlighted in the first half of the script. Many of the page corners exhibit having been folded over, and the script exhibits some minor staining. Dimensions: 11" x 8.75" x 0.75" (28 cm x 22 cm x 1.5 cm)

**Estimate: \$2,000 - 4,000**

**780**  
 Mario Kirner Collection:  
 Crew T-shirt and Fleece  
**Freddy Vs. Jason (2003)**

A crew T-shirt and fleece from the production of Ronny Yu's horror crossover Freddy vs. Jason. This lot consists of a black visual effects crew T-shirt (size M) with a red graphic design of the villain's key weapons; the glove and the machete surrounded by blood splatters printed on the front, and an unsized black Helly Hansen fleece which has the depictions of Freddy's (Robert Englund) burnt face and Jason's (Ken Kirzinger) hockey mask, striking a strong resemblance to the comedy and tragedy drama masks, embroidered on the left chest. The T-shirt exhibits fading from sun damage. Additional Provenance: This lot comes from the personal collection of Friday the 13th collector and historian Mario Kirner.

**Estimate: \$300 - 600**

**781**  
 Mario Kirner Collection:  
 Westin Hills Clinic Blueprint  
**Freddy Vs. Jason (2003)**

A Westin Hills Clinic blueprint from the production of Ronny Yu's horror crossover Freddy vs. Jason. Lori (Monica Keena), Kia (Kelly Rowland) and Will (Jason Ritter) frantically searched the kitchen of the Westin Hills clinic for Hypncil after realising they can use it to prevent dreams and protect themselves from Freddy (Robert Englund). This blueprint is titled "Cabinetry Details" and features several elevations with printed measurements and annotations. It is dated "9/13/02" and includes "SPFX" handwritten in black ink. The print comes folded and exhibits fold lines and minor edge tears. Dimensions (folded): 12.5" x 10" (32 cm x 25 cm) Additional Provenance: This lot comes from the personal collection of Friday the 13th collector and historian Mario Kirner.

**Estimate: \$500 - 1,000**



**782**  
 Mario Kirner Collection:  
 Storyboard File  
**Freddy Vs. Jason (2003)**

A storyboard file from the production of Ronny Yu's horror crossover Freddy vs. Jason. The file contains printed storyboards for multiple sequences, including the opening scene and the cornfield rave massacre. There are over 300 pages in total and they are held together in a black ring binder. Different sequences have been drawn by different artists. Some of the pages have been creating, very minor staining and the first page is loose. Dimensions (file): 11.5" x 11.5" x 3.25" (29.5 cm x 29 cm x 8 cm)

**Estimate: \$700 - 1,400**

**783**  
 Mario Kirner Collection:  
 Bear Trap and SFX Leg  
**Friday The 13th (2009)**

A bear trap and SFX leg from Marcus Nispel's horror reboot Friday the 13th. Richie (Ben Feldman) stepped into a bear trap while trying to rescue his girlfriend Amanda (America Olivo) from Jason Voorhees (Derek Mears). This lot comes from the collection of Friday the 13th collector and historian Mario Kirner. The metal trap features rubber-tooth jaws, dual springs, a circular plate, stock bar, and a chain. The flesh-colored foam latex leg features hand-stitched hair, an open wound, a rubber-soled sneaker, sock, and jean remnants. Included is a studio letter of authenticity. The trap exhibits production-added distressing, and the leg exhibits stage bloodstains. Dimensions: (leg) 27.5" x 12" x 6" (70 cm x 30 cm x 15 cm); (trap) 26.5" x 18.5" x 13.5" (67 cm x 47 cm x 34 cm)

**Estimate: \$3,000 - 6,000**

**784**  
 Mario Kirner Collection: Pamela Voorhees' (Nana Visitor) Locket  
**Friday The 13th (2009)**

Pamela Voorhees' (Nana Visitor) locket from Marcus Nispel's horror reboot Friday the 13th. This lot comes from the personal collection of Friday the 13th collector and historian Mario Kirner. As a child, Jason Voorhees (Derek Mears) retrieved his mother's locket from her decapitated body, and decades later, Jason was tossed into the lake with the locket at the end of the film. This lot is the locket that was thrown into the lake and used for underwater scenes. It is made of lightweight resin and has been hand-painted on both sides in an intricate floral design to match the locket version used for close-up shots. Tied to the bail of the locket is an olive green cotton necklace string with velvet inlay. The item exhibits deliberately added production wear to reflect its age. Dimensions: 17" x 1.5" x 0.75" (43 cm x 4 cm x 2 cm)

**Estimate: \$2,000 - 4,000**





**785**  
Mario Kirner Collection: Screwdriver Set  
**Friday The 13th (2009)**

A screwdriver set from Marcus Nispel's horror reboot Friday the 13th. Jason Voorhees (Derek Mears) killed Chewie (Aaron Yoo) by driving a screwdriver into his throat. This lot comes from the personal collection of Friday the 13th collector and historian Mario Kirner. The set consists of one hero metal screwdriver with rubber, retractable, and rubber-tipped versions. The handles feature grooved black grips and, apart from the full rubber screwdriver, are made of green plastic. They exhibit intentional distressing by production to appear used. Dimensions: (each) 13.5" x 1.5" x 1.5" (34 cm x 3 cm x 3 cm)

**Estimate: \$1,500 - 3,000**



**786**  
Mario Kirner Collection:  
Bear Trap and Crystal Lake Postcard  
**Friday The 13th (2009)**

A bear trap and Crystal Lake postcard from Marcus Nispel's horror reboot Friday the 13th. Bear traps featured throughout the film. This lot comes from the personal collection of Friday the 13th collector and historian Mario Kirner. This faux bear trap is made of metal, plastic and resin with dual spring levers and a circular plate. The postcard features an image of Crystal Lake. Both items were used as background decoration in the film and were supplied by the prop master. The trap exhibits production-added distressing. Dimensions: (trap) 12" x 9.5" x 5" (30 cm x 24 cm x 12.5 cm); (postcard) 7" x 5" (18 cm x 13 cm)

**Estimate: \$600 - 1,200**



**787**  
Three Skull Heads with Wall Sconce  
**From Dusk Till Dawn (1996)**

Three skull heads with a wall sconce from Robert Rodriguez's horror thriller From Dusk Till Dawn. The strip club, Titty Twister, was decorated with stone skulls and wall sconces as the apex of an Aztec pyramid. These three skulls and one metal wall sconce come from the collection of on-set dresser McPherson O. Downs. Made of foam, the skulls feature a stone-textured front, painted in various shades of brown and gray to resemble rock. Production distressed these skulls and sconce to give the appearance of age and wear. This lot exhibits discoloration, rust, minor chipping, and cracks in the foam. Dimensions: (each) 12" x 10" x 4" (30.5 cm x 25.5 cm x 10.24 cm)

**Estimate: \$1,500 - 3,000**



**788**  
Four Skull Heads with Wall Sconce  
**From Dusk Till Dawn (1996)**

Four skull heads with a wall sconce from Robert Rodriguez's horror thriller From Dusk Till Dawn. The strip club, Titty Twister, was decorated with stone skulls and wall sconces as the apex of an Aztec pyramid. These four skulls and one metal wall sconce come from the collection of on-set dresser McPherson O. Downs. Made of foam, the skulls feature stone-textured fronts painted in various shades of brown and gray to resemble rock. Production distressed these skulls and sconce to give the appearance of age and wear. This lot exhibits discoloration, rust, minor chipping, and cracks in the foam. Dimensions: (each) 12" x 10" x 4" (30.5 cm x 25.5 cm x 10.24 cm)

**Estimate: \$1,500 - 3,000**

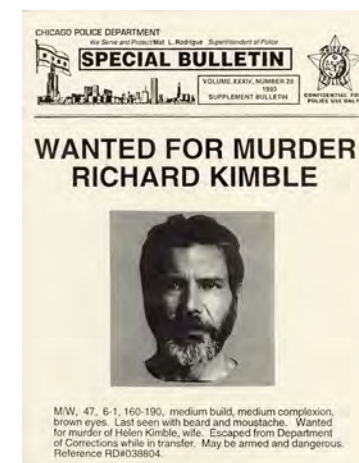

**789**  
Production-Made Richard Kimble  
(Harrison Ford) Wanted Poster  
**The Fugitive (1993)**

A production-made wanted poster for Dr. Richard Kimble (Harrison Ford) from Andrew Davis' action thriller The Fugitive. The Chicago Police Department distributed special bulletins calling for the arrest of Kimble, who was framed for murder. Created by Earl Hays Press for the production, this "Wanted for Murder" poster is printed in black-and-white on letter-sized Chicago Police Department letterhead and dated "1993" with a picture and description of Kimble and his alleged crimes. The paper exhibits minor discoloration from age. Dimensions: 8.5" x 11" (21.75 cm x 28 cm)

**Estimate: \$1,000 - 2,000**



**791**  
Nano-Mite Bomb  
**G.I. Joe: The Rise Of  
Cobra (2009)**

A nano-mite bomb from the Paramount Pictures action adventure G.I. Joe: The Rise of Cobra. MARS Industries' primary weapon throughout the film, the bombs were filled with nano-mites capable of breaking down metal compounds. This lot consists of a clear glass chamber with a metal pointed headpiece, frame, and handle. The chamber is filled with transparent liquid submerging metal components within. The liquid, formerly green, exhibits browning from age and a thin film has grown on the submerged components. Dimensions: 18" x 3.25" x 3.25" (45.75 cm x 8.5 cm x 8.5 cm)

**Estimate:  
\$2,500 - 5,000**



**790**  
Private Cowboy's (Arless Howard) Helmet Cover with  
Insect Repellent Bottle and Vietnam-Era Helmet  
**Full Metal Jacket (1987)**

Private Cowboy's (Arless Howard) helmet cover with an insect repellent bottle affixed to a Vietnam-era helmet from Stanley Kubrick's war-drama Full Metal Jacket. Pvt. Cowboy wore his helmet when his platoon was bombed during a patrol. This lot consists of an original fiberglass helmet wrapped in a green camouflage cloth; a dark green metal helmet; and a black rubber strip securing an empty white plastic insect repellent bottle to the side. The metal helmet and repellent were added to complete the lot. The helmet features a handwritten calendar from December to March, "SHORT" on the back, and "That'll be the Day" along the side. This helmet exhibits intentional distressing.

**Estimate: \$1,500 - 3,000**



**792**  
Storm Shadow's  
Stunt Paris Costume  
and Katanas  
**G.I. Joe: The Rise Of  
Cobra (2009)**

Storm Shadow's stunt Paris costume and katanas from Paramount Pictures' action adventure G.I. Joe: The Rise of Cobra. Storm Shadow wore his costume in Paris where he and the Baroness attempted to release the nanomites. This cream-color wool three-piece suit is accompanied by one white dress shirt hand-marked for the principal actor and "harness," three pairs light-color cotton socks, one cream-color leather belt, and glossy dress shoes with their original box. Included are two wooden katanas painted metallic with metal tsuba, red pattern decals, and white handle wraps; eight wardrobe tags with stunt markings, additional costume information, and one reading "Do Not Use - Stains." The vest's pocket label is hand-marked "Dark Sky." The costume exhibits staining. Dimensions: (larger katana) 37" x 3.5" x 3.5" (94 cm x 9 cm x 9 cm)

**Estimate:  
\$2,000 - 4,000**

**793**  
**Baroness' Stunt Convoy Ambush Costume**  
**G.I. Joe: The Rise Of Cobra (2009)**



Baroness' stunt convoy ambush costume from Paramount Pictures' action adventure G.I. Joe: The Rise of Cobra. Baroness wore her costume during the ambush of Duke and Ripcord's convoy. The lot consists of one custom-made black long-sleeve leather bolero with black metal studs marked with a sewn-in costumer's tag marked "harness" and for the stunt performer, one black leather corset with a rear zipper and an identically marked costumer's tag, one black long-sleeve thermal undershirt, black leatherette trousers with attached boots marked for the stunt performer, black leather gloves, and black leather cuffs marked for the stunt performer. The costume exhibits extensive flaking to the faux leather finish of the pants.

**Estimate:**  
**\$1,500 - 3,000**



**795**  
**Scarlett's Screen-Matched Stunt Pit Costume**  
**G.I. Joe: The Rise Of Cobra (2009)**

Scarlett's screen-matched stunt Pit costume from Paramount Pictures' action adventure G.I. Joe: The Rise of Cobra. Scarlett wore her costume in the G.I. Joe headquarters known as "The Pit." This costume screen-matches to shots in the early part of the fight against The Baroness in The Pit. This costume consists of one gray urban camouflage jumpsuit marked "Scarlett Stunt" with a zippered front; one matching balaclava marked for the principal performer; a pair of silver-color metal hoop earrings; a gray cotton-nylon blend tank top; a pair of black cotton socks; and six wardrobe tags marked for a stunt performer. The costume exhibits light staining from production wear and age.

**Estimate:**  
**\$1,000 - 2,000**



**794**  
**Snake Eyes' Costume Components and Wooden Katana**  
**G.I. Joe: The Rise Of Cobra (2009)**

Snake Eyes' costume components and wooden katana from Paramount Pictures' action adventure G.I. Joe: The Rise of Cobra. Snake Eyes donned various costumes depending on his environment, including his signature all-black costume as well as his white arctic costume, which he wore during the assault on the MARS base. This lot consists of one black long-sleeve polyester-blend athletic undershirt marked for a stunt performer, black cotton-blend cargo trousers with a wardrobe tag reading "Snake Eyes Backup - Too Large Do Not Use," one white fleece gaiter-style arctic facemask for covering the lower face, and one wooden katana painted to resemble metal with a metal tsuba, red pattern decals, and a black handle. The undershirt exhibits light staining while the katana exhibits cracking and scuffing in the paint. Dimensions: (katana) 36" x 3.5" x 3.5" (91.5 cm x 9 cm x 9 cm)

**Estimate:**  
**\$1,500 - 3,000**



**796**  
**Convoy Viper Costume**  
**G.I. Joe: The Rise Of Cobra (2009)**

A convoy viper costume from Paramount Pictures' action adventure G.I. Joe: The Rise of Cobra. Vipers wore their costumes during the ambush of Duke and Ripcord's convoy. This costume consists of one black long-sleeve zip-up tactical jacket; front and back torso armor with a rubber scale effect finished in black and metallic gray paint, padding, fastening strips, and plastic buckles; black rubber belt components; a padded neck piece; black leather-wrapped plastic shoulder armor components with fastening strip straps, matching forearm armor components with fastening strip straps; padded leather gloves; distressed gray-painted leather trousers with boot stirrups and rubber scale armor; and black leather and rubber boots. The costume exhibits staining and scuffing.

**Estimate:**  
**\$1,000 - 2,000**

**797**  
**Breaker's Pit Costume and ID Badge**  
**G.I. Joe: The Rise Of Cobra (2009)**

Breaker's pit costume and ID badge from Paramount Pictures' action adventure G.I. Joe: The Rise of Cobra. Breaker wore his costume in the G.I. Joe headquarters known as "The Pit." This costume consists of one gray camouflage zip-up cargo vest marked "Breaker" which screen-matches to The Pit scenes; matching fatigue trousers marked "Breaker #2"; a black and gray fabric blend long-sleeve zip-collared athletic top marked "Breaker" embroidered with an G.I. Joe eagle chest patch; a black woven nylon belt; black and brown rubber and nylon-blend elbow pads; matching black knee pads; and a gray plastic ID badge labeled "Breaker" with the G.I. Joe eagle logo and other fine print details. The ID exhibits finish scuffing.

**Estimate: \$500 - 1,000**



**798**  
**Fatu-Krey Pod Gun** Δ  
**Galaxy Quest (1999)**

A Fatu-Krey pod gun from Dean Parisot's sci-fi comedy Galaxy Quest. The warlord Roth'har Sarris' (Robin Sachs) and his Fatu-Krey soldiers wielded pod guns when they took over the NSEA Protector. This gun is constructed from cast resin and plastic with metal components, faux snakeskin covering, twin rope accents, and a rotating barrel operated by a switch. Also included is a custom black display base engraved with the film title. The gun is intentionally distressed to appear well-used. It has undergone sympathetic repair, and exhibits chipped paint and scratches. Dimensions: 19" x 12" x 16" (48.25 cm x 30.5 cm x 40 cm)

Contains electronics; see electronics notice in the Buyer's Guide.

**Estimate: \$2,000 - 4,000**



**799**  
**Sarris' Guard (Derrick Nugent) Costume** Δ  
**Galaxy Quest (1999)**

Sarris' guard (Derrick Nugent) costume from Dean Parisot's sci-fi dramedy Galaxy Quest. Sarris' (Robin Sachs) troops boarded the NSEA Protector in his quest for domination against the Thermians. This costume consists of a full-length army green cotton zip-front jumpsuit with painted spots to mimic a reptilian look and aged with brown and green textured plastic spaulders to resemble an animal's exoskeleton, hand-marked "7 DERRICK NUGENT" on the tag with black pen; a matching balaclava; a thigh-length brown and dark green rubber and latex vest with snap and hook-and-loop-laden straps and hand-marked "Derrick Front" and "Derrick Back"; and a resin brown aged codpiece attached to a green cotton fabric belt hand-marked "L" and "Derrick Nugent #7" on reverse. The lot exhibits surface wear, missing textures, and fraying.

**Estimate: \$600 - 1,200**



**800**  
**John Duncan Collection: NSEA Protector Separated Command Deck Model Miniature Components**  
**Galaxy Quest (1999)**

NSEA Protector separated command deck model miniature components from Dean Parisot's sci-fi comedy Galaxy Quest. Jason Nesmith (Tim Allen) led his crew aboard the NSEA Protector as they prepared to crash land on Earth. These three vacuum-formed plastic miniature components from the command deck's bottom panel and the NSEA Protector's top panels come from the collection of lead model maker John Duncan, who created them. Painted white and gray, they feature tape marked "Screws" to insert in the holes along the edges. The set exhibits grime, tape residue, and some missing screws. Dimensions: 24" x 8.75" x 1" (61 cm x 22.25 cm x 2.75 cm)

**Estimate: \$1,000 - 2,000**



**801**  
 Conrad Van Orton's  
 (Sean Penn) Costume  
**The Game (1997)**

Conrad Van Orton's (Sean Penn) costume from David Fincher's thriller *The Game*. Conrad wore his suit to his brother Nicholas' (Michael Douglas) birthday party. This costume consists of a black silk bow tie; a double-breasted, cream-color polyester blazer with three internal pockets; a white button-up shirt; black trousers with a black side stripe; two white silk cord cufflinks in an envelope; a white elastic strap with four buttons; three production tags hand-marked "Sean Penn" and "Take Clean Outfit" and an 8" x 10" (20.5 cm x 25.5 cm) wardrobe department inventory list of "Box 10" for "Conrad Sean Penn." This costume exhibits discoloration.

**Estimate:**  
**\$1,000 - 2,000**



**802**  
 Paul Brenner's  
 (John Travolta) Army  
 Dress Uniform  
**The General's  
 Daughter (1999)**

Paul Brenner's (John Travolta) army dress uniform from Simon West's crime-drama film *The General's Daughter*. Brenner wore his uniform when he approached General Joseph Campbell (James Cromwell) with his findings about his daughter's death. This lot consists of a dark army green jacket and trousers that are marked "John Travolta July 1998"; a light green button-down shirt labeled "JT Sep 1998"; a black nylon belt with a gold-color metal buckle; a dark army green cap (size 7 1/4) with a gold-color metal army pin; black dress shoes; a black polyester tie; and two black polyester epaulets. This lot exhibits deterioration on the shoes.

**Estimate:**  
**\$1,200 - 2,400**



**803**  
 Paul Brenner's  
 (John Travolta) Costume  
**The General's  
 Daughter (1999)**

Paul Brenner's (John Travolta) costume from Simon West's crime-drama film *The General's Daughter*. Brenner wore his costume when he examined a raped and tortured female corpse in a bomb squad training area. This lot consists of a beige jacket and matching trousers marked "John Travolta July 1998"; a white button-down shirt marked "JT July 1998"; a blue and gray tie; a red leather belt; red leather shoes with prescription insoles marked "Jack Smith"; beige socks; two sets of beige socks; and a beige cotton towel. This lot exhibits minor stains to the jacket and worn soles on the shoes.

**Estimate:**  
**\$1,000 - 2,000**



**804**  
 Paul Brenner's  
 (John Travolta)  
 Screen-Matched  
 Undercover Costume  
**The General's  
 Daughter (1999)**

Paul Brenner's (John Travolta) undercover costume from Simon West's crime drama *The General's Daughter*. Patterns on this costume screen-match to the one Brenner wore when he worked undercover to catch an arms dealer. This costume consists of a green camouflage cotton jacket featuring army patches and the name tag "WHITE" (size XL-Long) marked "WHITE 7 of 8"; matching camouflage trousers (size L) marked "JT"; a matching camouflage hat featuring an army patch (size 7 1/4 L); a brown cotton shirt; a black nylon belt with a black metal buckle; and black leather lace-up boots marked "11 1/2 WCC WS." This lot exhibits minor creases from folding.

**Estimate:** **\$600 - 1,200**



**805**  
 Temple of Gozer  
 Door Model Miniature  
**Ghostbusters (1984)**

A Temple of Gozer door model miniature from Ivan Reitman's supernatural comedy *Ghostbusters*. After possessing Dana Barrett (Sigourney Weaver) and Louis Tully (Rick Moranis), Zuul and Vinz Clortho completed their ritual and opened supernatural portal doors to reveal the Temple of Gozer. This resin door miniature is engraved with staircase and temple symbols with five figures on the front and painted turquoise over brown to resemble a patina from age. The lot exhibits pitting from the curing process, holes, chipped paint, and missing pieces. Dimensions: 25" x 21" x 1" (65 cm x 53.5 cm x 2.75 cm)

**Estimate:** **\$5,000 - 10,000**



**806**  
 Temple of Gozer Topper Art  
 Department Study Model  
**Ghostbusters (1984)**

A Temple of Gozer topper art department study model from Ivan Reitman's supernatural comedy *Ghostbusters*. The ancient, apocalypse-heralding Gozer (Slavitzta Jovan) appeared in her temple atop Dana Barrett's (Sigourney Weaver) apartment building after Zuul possessed Dana and Keymaster possessed Louis Tully (Rick Moranis) to complete their ritual. Designed by production designer John De Cuir, this study model is made from foam core with clay sculpted features painted tan and off-white to resemble stonework. This lot exhibits surface cracking, gashes, scratches, and paint chipping. Dimensions: (display) 17.75" x 13.75" x 12.5" (45 cm x 35 cm x 31.75 cm)

**Estimate:** **\$2,000 - 4,000**



**807**  
 Stuart Ziff Collection:  
 Set of Three Terror Dog Claws  
**Ghostbusters (1984)**

Three terror dog claws from Ivan Reitman's supernatural comedy *Ghostbusters*. A terror dog kidnapped Dana Barrett (Sigourney Weaver) to take her to become a servant of Gozer. This set comes from the collection of Ghost Shop creature effects supervisor Stuart Ziff. It consists of three textured and carved resin terror dog claws painted brown. One claw features a hole for attachment and one claw is hollow within. These claws exhibit rough edges and foam residue. Dimensions: (largest) 4.5" x 2" x 1.25" (11.5 cm x 5 cm x 3.25 cm)

**Estimate:** **\$1,500 - 3,000**

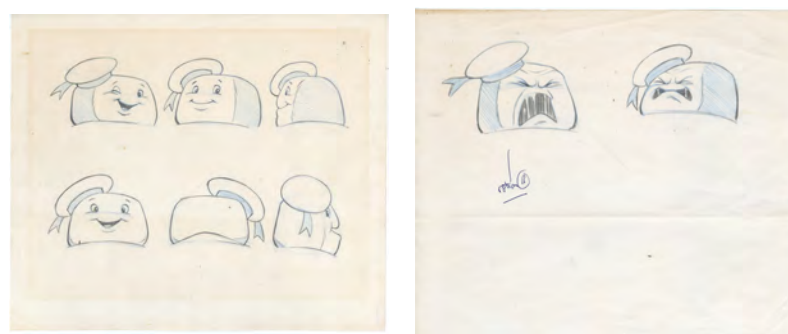

**808**  
Stuart Ziff Collection:  
Hand-Drawn Stay Puft Expression Concept Sketches  
**Ghostbusters (1984)**

Hand-drawn Stay Puft Marshmallow Man expression concept sketches from Ivan Reitman's supernatural comedy Ghostbusters. Concept sketches helped production finalize designs. These two pages of concept sketches come from the collection of Ghost Shop creature effects supervisor Stuart Ziff. Rendered in blue pencil and graphite, one page features six sketches of a character turnaround of the Stay Puft Marshmallow Man's head, and the second page features two sketches of an angry Stay Puft. The second page is hand-marked with "option B" and a line drawn to the left figure in black pen. This lot exhibits discoloration from age, faint fold lines, and notable marks. Dimensions: 11" x 8" (28 cm x 20.5 cm) Sold without copyright; see notice in the Buyer's Guide.

Estimate: \$1,200 - 2,400



**810**  
Stuart Ziff Collection: Stuart Ziff's Crew Jacket  
**Ghostbusters (1984)**

Ghost Shop creature effects supervisor Stuart Ziff's personal crew jacket from Ivan Reitman's supernatural comedy Ghostbusters. This silver-color, nylon-blend sportswear jacket comes from Ziff's collection. It features a mauve satin lining, zip-front closure, collar strap with snaps, front slit pockets, and elastic silver-color nylon cuffs and waistband. A single Ghostbusters "No Ghost" embroidered logo features atop the right chest. The jacket exhibits minor staining, a mostly detached neck tag, small holes in the back, and minor loose threads.

Estimate: \$600 - 1,200

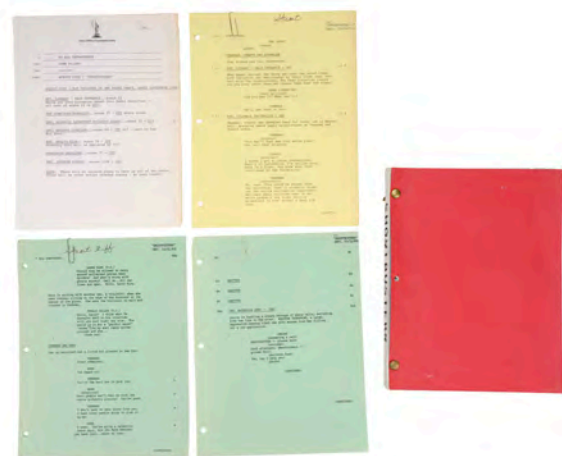

**809**  
Stuart Ziff Collection: Bound Revised  
Third Draft Script with Production Paperwork  
**Ghostbusters (1984)**

Ghost Shop creature effects supervisor Stuart Ziff's personal bound, revised third draft script with paperwork from the production of Ivan Reitman's supernatural comedy Ghostbusters. This lot comes from Ziff's collection. It consists of a brass brad-bound, 138-page script credited to Dan Aykroyd and Harold Ramis, dated "7 October 1983," hand-marked "1006 Stuart Ziff" on the cover, and enclosed in a red folder; eight yellow script revision pages handmarked "Stuart"; two white production memoranda handmarked "Stu"; and five green script revision pages. The paperwork exhibits edge wear, dog earring, and rodent bites from storage. Dimensions: (largest) 8.5" x 11" x 1" (21.5 cm x 28 cm x 2.5 cm)

Estimate: \$1,500 - 3,000



**811**  
Set of Behind-the-Scenes Stills and Studio Negatives  
**Ghostbusters (1984)**

Behind-the-scenes stills and studio negatives from the production of Ivan Reitman's sci-fi comedy Ghostbusters. This set consists of two black-and-white glossy production stills of Dana Barrett (Sigourney Weaver) and Louis Tully (Rick Moranis); four black-and-white glossy behind-the-scenes stills featuring Harold Ramis and the Terror Dog statues; and three Columbia Pictures lab negatives featuring the Ghostbusters and the Ecto-1, one of which is unpublished. Each still is hand-numbered and stamped with the Columbia Pictures copyright on the reverse. The set exhibits bending and edge wear throughout from handling. Dimensions: (each) 8.5" x 11" (21.75 cm x 28 cm)

Estimate: \$1,500 - 3,000



**812**  
Production-Made  
Ghostbusters Life Magazine Cover  
**Ghostbusters II (1989)**

A production-made Life magazine cover featuring the Ghostbusters from the production of Ivan Reitman's supernatural comedy sequel Ghostbusters II. Publications about the Ghostbusters' achievements hung in Peter Venkman's (Bill Murray) firehouse office throughout the film. Created by Earl Hays Press for the production, this uncut Life magazine cover featuring a picture of Venkman, Ray Stantz (Dan Aykroyd), Egon Spengler (Harold Ramis), and Winston Zeddemore (Ernie Hudson) beneath the headline "A Day in the Life of a Ghostbuster (A 4-Page Pictorial)" is color-printed on white paper. The paper exhibits smudging and staining throughout its margins. Dimensions: 13" x 19" (33 cm x 48.25 cm)

Estimate: \$800 - 1,600



**813**  
Set of Four  
Production-Made Ecto-1A Decals  
**Ghostbusters II (1989)**

Four production-made Ecto-1A decals from the production of Ivan Reitman's supernatural comedy sequel Ghostbusters II. The reunited Ghostbusters updated the Ecto-1A with a new two-fingered No-Ghost logo. Printed by Earl Hays Press for the Ecto-1A's door and tailgate, this set consists of two unpeeled black, white, and red two-fingered No-Ghost decals, a matching unpeeled sticker, and an unpeeled No-Ghost decal in the style of those created for the first film. They exhibit discoloration, creasing, and staining from production. Dimensions: (each) 18" x 20" (45.75 cm x 51 cm)

Estimate: \$1,000 - 2,000



**814**  
Bill Murray-Autographed  
Promotional Still  
**Ghostbusters (1984)**

A Bill Murray-autographed promotional still of Dr. Peter Venkman (Bill Murray) from Ivan Reitman's supernatural comedy Ghostbusters. This black-and-white still is printed on glossy photo stock featuring the Columbia Pictures copyright in the bottom white border and signed "Linda Take Tomorrow Off. Ok" in black marker by Murray. The reverse is blank and exhibits some smudging from handling. Dimensions: 10" x 8" (25.5 cm x 20.5 cm)

Estimate: \$800 - 1,600



**815**  
Set of Slimer and Scoleri Brothers Maquettes  
**Ghostbusters II (1989)**

Slimer and Scoleri Brothers maquettes from Ivan Reitman's action-comedy sequel Ghostbusters II. Slimer vexed Tully (Rick Moranis) throughout the film, while the ghoulish Scoleri Brothers ran amok during court proceedings against the Ghostbusters. These maquettes were created by Industrial Light & Magic (ILM) as design references for the character puppets. The Slimer maquette is made from brown resin mounted to a black base, while the white plaster Brothers maquettes are painted gray. ILM sculptor Mark Siegel and "10/88" are engraved on one Scoleri's back. Each maquette exhibits scratching and paint chipping. Dimensions: 17" x 5" x 8" (43.25 cm x 12.75 cm x 20.5 cm)

**Estimate: \$4,000 - 8,000**



**816**  
Set of Two Slimers and Scoleri Brother Maquettes  
**Ghostbusters II (1989)**

Two Slimers and a Scoleri Brother maquette from Ivan Reitman's action-comedy sequel Ghostbusters II. Slimer vexed Tully (Rick Moranis) throughout the film, while the ghoulish Scoleri Brothers ran amok during court proceedings against the Ghostbusters. These maquettes were created by Industrial Light & Magic (ILM) as design references for the character puppets. One Slimer maquette is made from brown resin mounted to a black base, while the other is a translucent amber resin also mounted to a black base. The Scoleri Brother maquette is composed of white plaster painted gray. All three maquettes exhibit scratching and paint chipping, while the Scoleri Brother has a broken base. Each Slimer also exhibits a missing finger. 17" x 5" x 8" (43.25 cm x 12.75 cm x 20.5 cm)

**Estimate: \$3,000 - 6,000**



**817**  
Kevin Beckman's Screen-Matched  
Hand-Painted Motorcycle Helmet  
**Ghostbusters (2016)**

Kevin Beckman's screen-matched hand-painted motorcycle helmet from Paul Feig's supernatural comedy Ghostbusters. Dots and incongruities on the lettering of this helmet screen-match it to when Beckman (as played by Chris Hemsworth) held his helmet while standing next to the "Echo-2", trying to convince the Ghostbusters to let him be a more active part of the team. This helmet features a black fiberglass shell, black padded interior with red thread, metal-buckled chin strap, metal snaps for visor attachments, and hand-painted details including the word "Ghostbuster" on the front and the iconic No-Ghost logo on the sides. The helmet exhibits some scuffing throughout. Dimensions: 12" x 11" x 10" (30.5 cm x 28 cm x 25.5 cm)

**Estimate: \$1,200 - 2,400**



**818**  
Light-Up Stunt Ghost Chipper  
**Ghostbusters (2016)**

A light-up stunt ghost chipper from Paul Feig's supernatural comedy Ghostbusters. After a conversation with Mayor Bradley (as played by Andy Garcia), Dr. Jillian Holtzmann (as played by Kate McKinnon) created several new weapons to combat New York City's ghosts, including a device which sucked in and shredded them. This gray rubber and plastic "chipper" features a pair of hand-grips and openings at the front and rear. Pressing a 9 volt battery-operated switch on the bottom of the device activates a pair of red lights on one side. It exhibits signs of wear and use. Dimensions: 14" x 7" x 7" (35.5 cm x 17.75 cm x 17.75 cm) Contains electronic components; see notice in the Buyer's Guide.

**Estimate: \$2,000 - 4,000**



**820**  
Stunt Proton Wand  
**Ghostbusters (2016)**

A stunt proton wand from Paul Feig's supernatural comedy Ghostbusters. The Ghostbusters wore their proton packs, specialized devices that used hand-held wands to wrangle ghosts into traps, throughout the film. This wand goes with the V-3 style proton pack. This rubber wand is painted to simulate metal, with three switches, one knob, and one button. A silver-color cable and wires run from the back of the wand's metal frame. A fastening strip panel hides a plug for a battery pack. The metal wand-end, wrapped in small lights with another light in the tip beneath a red gel, plugs into the barrel. The wand exhibits scuffing and tears. Dimensions (wand): 31.5" x 6.25" x 4.5" (80 cm x 16 cm x 11.5 cm); (wand-end): 13" x 1.5" x 1.5" (33.25 cm x 4 cm x 4 cm) Contains electronic components; see notice in the Buyer's Guide.

**Estimate: \$2,000 - 4,000**



**819**  
Proton Snare Glove  
**Ghostbusters (2016)**

A proton snare glove from Paul Feig's supernatural comedy Ghostbusters. After a conversation with Mayor Bradley (as played by Andy Garcia), Dr. Jillian Holtzmann (as played by Kate McKinnon) created several new weapons to combat New York City's ghosts, including a glove which dissolved ghosts by punching them. This black and silver-color plastic and resin "glove" features orange wire details and a black grip with a red button on the interior. The device separates into three pieces and reassembles via magnets. It exhibits extensive signs of wear from age and use. Dimensions: 10" x 6" x 4" (25.5 cm x 15.25 cm x 10.25 cm)

**Estimate: \$2,500 - 5,000**

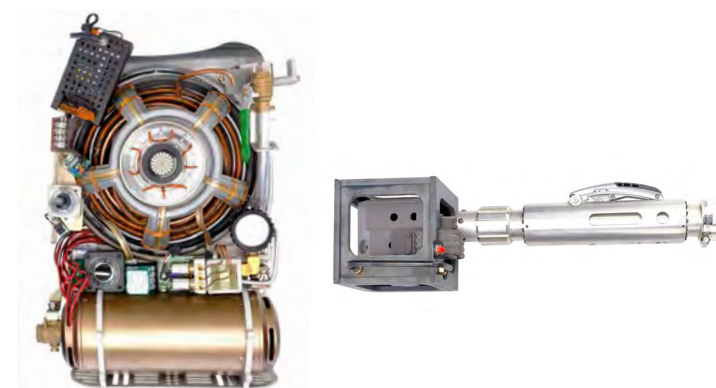

**821**  
Prototype Proton Pack and Wand  
**Ghostbusters (2016)**

A prototype proton pack and wand from Paul Feig's comedy-fantasy film Ghostbusters. The Ghostbusters team wielded proton wands connected to proton packs as they apprehended entities in New York. This lot consists of a silver-color metal proton wand with a gray-color resin casing and metal handles; a gray and orange canvas padded harness; and a metal, acrylic, and urethane proton pack with various metal cables and wires. This lot exhibits minor scuffs from production. Dimensions: 22" x 14" x 8.5" (56 cm x 35.75 cm x 21.75 cm) Contains electronics; see electronics notice in the Buyer's Guide.

**Estimate: \$2,000 - 4,000**



**822**  
Dr. Jillian Holtzmann's Stunt Upper Arm Remote Trigger and Light-Up Proton Pistol  
**Ghostbusters (2016)**

Dr. Jillian Holtzmann's stunt upper arm remote trigger and light-up proton pistol from Paul Feig's supernatural comedy Ghostbusters. Holtzmann (as played by Kate McKinnon) used her remote trigger to access her proton pistols during the battle in Times Square. This lot consists of a black and gray rubber trigger with cast details including non-functional knobs and switches, wiring running to a rubber control pad, and a foam-padded fastening strip arm strap. Also included is a foam rubber and resin pistol painted to simulate metal. It features red, yellow, and green lights illuminated by a small switch with a battery compartment hidden beneath a magnetically-attached panel. Both exhibit scuffing and tearing. Dimensions (trigger): 5" x 5" x 3" (12.75 cm x 12.75 cm x 7.75 cm); (pistol): 7" x 7.5" x 3" (18 cm x 19.25 cm x 7.75 cm) Ownership may be restricted in some countries; see replica firearm notice in Buyer's Guide. Contains electronic components; see notice in the Buyer's Guide.

**Estimate: \$1,500 - 3,000**



**824**  
Dr. Erin Gilbert's Proton Grenade Launcher with Holster  
**Ghostbusters (2016)**

Dr. Erin Gilbert's proton grenade launcher with a holster from Paul Feig's supernatural comedy Ghostbusters. Dr. Jillian Holtzmann (as played by Kate McKinnon) created several new weapons to combat New York City's ghosts, including a sidearm which fired proton grenades that Gilbert (as played by Kristen Wiig) used in the film's finale. This lot consists of a gray and black rubber pistol with a metal folding stock and an oversized barrel. It is affixed throughout with a series of red and yellow-color wires as well as decorative circuit boards. Also included is a black and gray nylon holster with a plastic clip. It exhibits signs of wear throughout from age and use including hot glue remnants. Dimensions: 12.5" x 10" x 7" (31.75 cm x 25.5 cm x 17.75 cm)

**Estimate: \$1,000 - 2,000**



**823**  
Light-Up Reel-to-Reel EVP Recorder  
**Ghostbusters (2016)**

A light-up reel-to-reel EVP recorder from Paul Feig's supernatural comedy Ghostbusters. The Ghostbusters used the recorder to capture and playback electronic voice phenomena (EVP) throughout the film. This Kudelski Nagra III recorder (with supply and take-up reels in place) is attached to a metal base with various switches and knobs, and adhered tech elements including circuit boards and computer fans. The base features red and green lights illuminated by a switch on the left side of the recorder with an attached power cord. While the lighting effects function, the recorder itself does not at this time. Various audio cables run from the recorder, two of which have been cut. Two additional cables are also included. The recorder exhibits some loose or unattached elements. Dimensions: 20" x 18" x 10" (51 cm x 45.75 cm x 25.5 cm) Contains electronic components; see notice in the Buyer's Guide.

**Estimate: \$1,200 - 2,400**



**825**  
Light-Up Proton Grenade  
**Ghostbusters (2016)**

A light-up proton grenade from Paul Feig's supernatural comedy Ghostbusters. Dr. Jillian Holtzmann (as played by Kate McKinnon) created a second variant of her proton grenade with three test-tube-like protrusions to use in battle against ghosts in Times Square. This grenade features a black resin body; three clear acrylic tubes wrapped in yellow and black striped tape, with red residue and white lights inside; a metal belt clip; an adhesive "1" label; and a red LED countdown timer. The countdown timer and the three tubes illuminate via a small switch on the side of the timer. A red button on the rear of the device starts and resets the timer. The grenade exhibits scuffing. Dimensions: 5.5" x 2.5" x 2" (14 cm x 6.5 cm x 2 cm) Contains electronic components; see notice in the Buyer's Guide.

**Estimate: \$400 - 800**



**826**  
Screen-Matched Proton Grenade Belt with Light-Up Grenades  
**Ghostbusters (2016)**

A screen-matched proton grenade belt with light-up grenades from Paul Feig's supernatural comedy Ghostbusters. This lot screen-matches to when Dr. Abby Yates (as played by Melissa McCarthy) wore her belt, which featured several proton grenades, during her final confrontation with a group of aggressive ghosts. This lot consists of a black and gray nylon belt with a black plastic clip affixed with three black and gray plastic and metal grenades with red wiring, LED lights, and red buttons on the top. Activating the light via a small switch causes the LEDs to illuminate and pressing the top button causes the lights to countdown. It exhibits signs of wear from age and use. Dimensions: 15.5" x 5" x 3" (39.5 cm x 12.75 cm x 7.75 cm) Contains electronic components; see notice in the Buyer's Guide.

**Estimate: \$700 - 1,400**



**828**  
Maximus Decimus Meridius' (Russell Crowe) Shoulder Straps  
**Gladiator (2000)**

Maximus Decimus Meridius' (Russell Crowe) shoulder straps from Ridley Scott's action epic Gladiator. This style of shoulder strap was unique to the cuirass that Roman general Maximus wore as he conversed with several of his soldiers after a decisive victory in Germania. These brown urethane straps feature metallic decorative accents on the ends. The underside of the straps include metal rings with leather cords which were used to anchor the shoulder straps to Maximus' breastplate. They exhibit minor signs of wear and discoloration on the top sections.

**Estimate: \$2,000 - 4,000**



**827**  
Dr. Jillian Holtzmann's Equipment Bag  
**Ghostbusters (2016)**

Dr. Jillian Holtzmann's equipment bag from Paul Feig's supernatural comedy Ghostbusters. Holtzmann (as played by Kate McKinnon) carried her ghostbusting equipment in her duffel bag throughout the film. This lot consists of a duffel bag with a silver-color blended-fabric exterior, zippered opening, fastening strip front flap with a black and yellow nuclear symbol patch; gray nylon straps; yellow plastic buckles; and gray metal carabiners. It exhibits signs of wear from use, including scuffing and staining throughout. Dimensions: 33" x 19" x 5" (84 cm x 48.5 cm x 12.75 cm)

**Estimate: \$700 - 1,400**



**829**  
Robert Duvall's "Tom Hagen" Title Card  
**The Godfather Part II (1974)**

Robert Duvall's "Tom Hagen" title card from Francis Ford Coppola's gangster sequel The Godfather Part II. Hagen was the Corleone crime family's consigliere and most trusted confidant throughout the franchise. The film's title cards and credits were produced by Pacific Title & Art Studio, where this card originated circa 1982. It consists of three black-and-white glossy paper cut-outs reading "Robert Duvall," "as," and "tom hagen" taped to sprocketed backing board hand-numbered "9," as Duvall's card was the ninth in the end credits. The tape exhibits yellowing from age and the board exhibits stains and folded corners. Dimensions: 12" x 15" (30.5 cm x 38.25 cm)

**Estimate: \$1,000 - 2,000**





**830**  
Opening and Closing Title Card Set  
**The Godfather (1972)**

Opening and closing title card set from Francis Ford Coppola's mafia drama *The Godfather*. Of note, the Paramount Gulf + Western title card first reportedly debuted in 1968's *The Odd Couple*. This lot features two production-used coated cardstock paper cards used in *The Godfather*'s final cut. The Paramount card features the printed logo and thicker typeface where curlicues are pronounced, and is mounted on a black cardstock. The *Godfather* card features an off-white printed logo on a black background. The lot exhibits tears, scuffing, edge wear, creasing, and residual tape residue. Dimensions: 22" x 14" x 0.25" (56 cm x 35.5 cm x 0.75 cm)

**Estimate: \$1,500 - 3,000**



**831**  
Cast-Autographed Pilot Script  
**The Golden Girls (1985-1992)**

A cast-autographed pilot script from Jay Sandrich's comedy-drama series *The Golden Girls*. Four women shared a home together in Miami, Florida through tough times and love. This 41-page pilot script written by Susan Harris and titled "Pilot" is bound in a goldenrod cardstock cover autographed by Bea Arthur, Rue McClanahan, Betty White, and Estelle Getty and is dated September 6, 1985. This lot exhibits minor red stains and fold creases from opening. Dimensions: 8.5" x 11" x 0.25" (21.75 cm x 28 cm x 0.75 cm)

**Estimate: \$3,000 - 6,000**

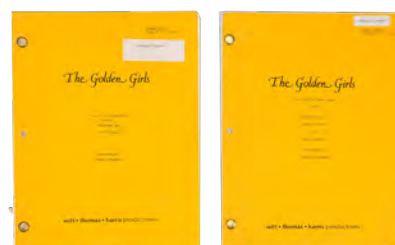

**832**  
Rich Weaver Collection: Blanche Devereaux's (Rue McClanahan) Gold Outfit, Autographed Book, and Two Scripts  
**The Golden Girls (1985-1992)**

Blanche Devereaux's (Rue McClanahan) gold outfit, autographed book, and two scripts from the comedy series *The Golden Girls*. In the Season 4 episode "You Gotta Have Hope," Devereaux wore her outfit during the charity benefit tryouts. This lot comes from the collection of Estelle Getty's personal assistant and friend, Rich Weaver. It consists of a gold-color silk button blouse (size M); matching trousers (size M); a ticket to see McClanahan at the Zachary Scott Theatre Center dated April 29, 2007; a McClanahan-autographed hardcover book of her memoir "My First Five Husbands...And the Ones Who Got Away;" and Estelle Getty's personal final draft scripts for the episodes "You Gotta Have Hope" and "Isn't It Romantic?" This lot exhibits minor loose threads on the trousers. Dimensions: (book) 6.25" x 9.5" x 1.25" (16 cm x 24.25 cm x 3.25 cm)

**Estimate: \$3,000 - 6,000**



**833**  
Rich Weaver Collection: Sonny Bono-Signed "Golden Girls Day in Palm Springs" Certificate and Script  
**The Golden Girls (1985-1992)**

A certificate proclaiming the commemoration of "Golden Girls Day" signed by Palm Springs Mayor Sonny Bono, and awarded to *Golden Girls* star Estelle Getty for her contributions to entertainment on November 2, 1990 and a script from the comedy series *The Golden Girls*. From the collection of Estelle Getty's personal assistant and friend, Rich Weaver, this fold-out certificate is printed on cream-color City of Palm Springs, California letterhead with red, black, and gold-color printed text and a gold-color ribbon applied to the interior. It is signed "Sonny Bono" in black ink. Also included is a final draft script for the Season 6 episode "Mrs. George Devereaux," in which Bono appeared, labeled for Estelle Getty. The certificate exhibits uneven edges, fold lines, and minor stains from handling. Dimensions: 9.25" x 16" (23.5 cm x 40.75 cm)

**Estimate: \$2,500 - 5,000**



**834**  
Rich Weaver Collection: Estelle Getty-Autographed Final Draft Scripts with Handwritten Wolfie's Letter  
**The Golden Girls (1985-1992)**

Estelle Getty-autographed final draft scripts with a handwritten Wolfie's letter from the comedy series *The Golden Girls*. This lot comes from the collection of Estelle Getty's personal assistant and friend, Rich Weaver. It consists of 13 brass brad-bound final draft scripts labeled "ESTELLE GETTY" with five featuring handwritten annotations and highlighter marks and two autographed by Getty; and one handwritten note from Wolfie's Restaurant to Getty on restaurant themed letterhead. This lot exhibits minor discoloration and edgewear from age. Dimensions: (each) 8.5" x 11" x 0.25" (21.75 cm x 28 cm x 0.75 cm)

**Estimate: \$2,500 - 5,000**



**835**  
Rich Weaver Collection: Estelle Getty-Autographed Script with Seven Additional Personal Scripts  
**The Golden Girls (1985-1992)**

An Estelle Getty-autographed script with seven additional personal scripts from comedy series *The Golden Girls*. This lot comes from the collection of Estelle Getty's personal assistant and friend, Rich Weaver. It consists of one 35-page final draft script from the Season 6 episode "Never Yell Fire in a Crowded Retirement Home: Part 2" autographed "Love and Laughter Estelle Getty" in ink; and seven final draft scripts featuring highlighter annotations and "Estelle Getty" on the covers. This lot exhibits minor stains. Dimensions: 8.5" x 11" x 0.25" (21.75 cm x 28 cm x 0.75 cm)

**Estimate: \$2,000 - 4,000**



**836**  
 Rich Weaver Collection: Estelle Getty-Autographed Script with Seven Additional Personal Scripts  
**The Golden Girls (1985-1992)**

An Estelle Getty-autographed script with seven additional personal scripts from comedy series The Golden Girls. This lot comes from the collection of Estelle Getty's personal assistant and friend, Rich Weaver. It consists of one 54-page final draft script from the Season 2 episode "Dorothy's Prized Pupil" autographed "Estelle" in black ink; and seven final draft scripts from Season 3, including a 54-page script from "Blanche's Little Girl" with paperclipped pages and a 45-page script from "Rose's Big Adventure" with handwritten notes. These scripts feature highlighter annotations and are labeled "Estelle Getty." This lot exhibits minor fold creases. Dimensions: 8.5" x 11" x 0.25" (21.75 cm x 28 cm x 0.75 cm)

**Estimate: \$2,000 - 4,000**



**837**  
 Rich Weaver Collection: Estelle Getty-Autographed Bound Script with Four Scripts and Ephemera  
**The Golden Girls (1985-1992)**

An Estelle Getty-autographed bound script with four scripts and ephemera from the comedy series The Golden Girls. This lot comes from the collection of Estelle Getty's personal assistant and friend, Rich Weaver, and consists of an autographed script for the third season episode "Larceny and Old Lace"; a spiral-bound Golden Girls-themed 1988 calendar autographed by Getty with a personal memo on the interior; six blank Golden Girls-themed Gibson greeting cards; and four additional brass-brad bound and annotated scripts for the first season's episodes "Transplant," and "Second Motherhood," and the second season's episodes "It's a Miserable Life," and "Before and After." This lot exhibits minor discoloration and edgewear from age. Dimensions: 8.5" x 11" x 0.25" (21.75 cm x 28 cm x 0.75 cm)

**Estimate: \$2,000 - 4,000**



**838**  
 Rich Weaver Collection: Set of Ten Final Draft Scripts and Three Estelle Getty Autographed Scripts  
**The Golden Girls (1985-1992)**

A set of ten final draft scripts and three Estelle Getty autographed scripts from the second and fourth seasons of the comedy series The Golden Girls. This lot comes from the collection of Estelle Getty's personal assistant and friend, Rich Weaver, and consists of three brass-brad bound autographed scripts for the episodes "'Twas the Nightmare Before Christmas," "Brother, Can You Spare That Jacket?," "The Impotence of Being Ernest," and 10 additional bound and annotated scripts for the episodes "Adult Education," "The Flu," "Big Daddy," "The Way We Met," "End of the Curse," "The Audit," "The Auction," "Love Me Tender," "Room 7," and "Old Boyfriends." This lot exhibits minor discoloration and edgewear from age. Dimensions: (each) 8.5" x 11" x 0.25" (21.75 cm x 28 cm x 0.75 cm)

**Estimate: \$2,000 - 4,000**



**839**  
 Rich Weaver Collection: Estelle Getty-Autographed Headshots, Crew Hat, Award Ephemera, and Two Scripts  
**The Golden Girls (1985-1992)**

Estelle Getty-autographed headshots, crew hat, award ephemera, and two scripts from the comedy series The Golden Girls. This lot comes from the collection of Estelle Getty's personal assistant and friend, Rich Weaver, and consists of one page of black-and-white headshots autographed by Getty; a black tuxedo tri-fold invitation for the 11th Annual American Comedy Awards dated February 9, 1997; Annual American Comedy Awards Honor Nominations for The Golden Girls (1987 and 1988); a black nylon Designer Award Headwear hat (FITS ALL) with "The Golden Girls" embroidered in gold-color thread on the front; and two scripts for "One Flew Out of the Cuckoo's Nest" Part I and Part II. This lot exhibits minor grime on the headshots and scripts. Dimensions: 8.5" x 11" x 0.25" (21.75 cm x 28 cm x 0.75 cm)

**Estimate: \$1,200 - 2,400**



**840**  
 Estelle Getty's Personal Cast-Gifted Paperweight  
**The Golden Girls (1985-1992)**

Estelle Getty's personal cast-gifted paperweight from the production of the comedy series The Golden Girls. The main cast gifted commemorative paperweights to those who worked on the series in 1985. This lot consists of a metal, star-shaped paperweight reading "The Golden Girls 1985 Love Bea Betty Rue Estelle" with a black felt bottom. It exhibits extensive scuffing and scratching throughout from use and age. Dimensions: 4" x 4" x 1.75" (10.25 cm x 10.25 cm x 4.25 cm)

**Estimate: \$1,000 - 2,000**



**841**  
 Rich Weaver Collection: Rue McClanahan's Wedding Invitation and Mail with TV Guide, Signed Scripts, and Autographed DVD Set  
**The Golden Girls (1985-1992)**

Rue McClanahan's wedding invitation and mail with a TV Guide, signed scripts, and an autographed DVD set of the comedy series The Golden Girls. This lot comes from the collection of Estelle Getty's personal assistant and friend, Rich Weaver. It consists of an invitation to McClanahan's wedding to Morrow Wilson with an envelope hand-addressed to Golden Girls co-star Estelle Getty; unopened letters addressed to McClanahan from Susan G. Komen For The Cure and the National Museum of African Art; a postcard-style flyer for McClanahan's production of Oklahoma, addressed to Getty from McClanahan; a small card to Getty from McClanahan; a TV Guide issue featuring The Golden Girls on the cover; final draft scripts for the episodes "Dorothy's New Friend" and "Foreign Exchange," both signed "Estelle," an "as broadcast" script for "Mother's Day," and a set of DVDs for The Golden Girls: Seasons 1 through 7, each signed on their boxes in black marker by McClanahan. Several autographs exhibit ink fade. Dimensions: (largest) 20" x 7.5" x 6" (51 cm x 19 cm x 15.25 cm)

**Estimate: \$800 - 1,600**

**842**  
 Rich Weaver Collection:  
 Betty White's Handwritten Letters to Estelle  
 Getty with Scripts and Promotional Ephemera  
**The Golden Girls (1985-1992)**



Betty White's handwritten letters to her *The Golden Girls* co-star Estelle Getty with scripts and various ephemera promoting the comedy series. This set comes from the collection of Estelle Getty's personal assistant and friend, Rich Weaver, and consists of two letters handwritten to Getty in ink on White's personal letterhead; a card from White to Getty featuring a photo of three dogs on the cover; a black-and-white photograph of Getty at the Guide Dogs for the Blind Holiday Luncheon; a "First Be Best Then Be First" NBC booklet with two pages of primetime audience estimates; a color-printed cast photo autographed by Getty, Rue McClanahan, and Bea Arthur; a color-printed headshot autographed by White; an issue of *Variety* promoting the 100th episode of *The Golden Girls*, an "as broadcast" script for the episode "Valentine's Day," and final draft scripts for the episodes "Scared Straight," "Till Death Do We Volley," "The Commitments," "Little Sister," "Questions & Answers," "Hey, Look Me Over," "Big Daddy's Little Lady," "Twice in a Lifetime," and "Never Yell Fire in a Crowded Retirement Home, Part I." The latter script doesn't have a traditional printed cover, but rather the cover is hand-marked "Clip Show #153". Four of the scripts are labeled for Getty and one is signed "Estelle." This lot exhibits minor discoloration, as well as corner and edge wear to the paper elements. Dimensions (scripts): 8.5" x 11" x 0.5" (21.75 cm x 28 cm x 1.5 cm)

**Estimate: \$800 - 1,600**

**843**  
 Rich Weaver Collection: One Estelle Getty-Signed  
 Script with Seven Additional Personal Scripts  
**The Golden Girls (1985-1992)**



One Estelle Getty-signed script with seven additional personal scripts from the comedy-drama series *The Golden Girls*. This lot comes from the collection of Estelle Getty's personal assistant and friend, Rich Weaver. It consists of one final draft script for the Season 2 episode "To Catch A Neighbor" signed "Estelle"; and seven final draft scripts from "Home Again Rose, Part I," "Home Again Rose, Part II," "Rose: Portrait of a Woman," and "Guess Who's Coming to the Wedding?" The scripts are labeled and marked for Getty with highlighting. This lot exhibits minor creases from handling and stains. Dimensions: (each) 8.5" x 11" x 0.25" (21.75 cm x 28 cm x 0.75 cm)

**Estimate: \$2,000 - 4,000**

**844**  
 Rich Weaver Collection: One Estelle Getty-Signed  
 Script with Seven Additional Personal Scripts  
**The Golden Girls (1985-1992)**



One Estelle Getty-signed script with seven additional personal scripts from the comedy-drama series *The Golden Girls*. This lot comes from the collection of Estelle Getty's personal assistant and friend, Rich Weaver. It consists of one final draft script for the Season 2 episode "A Piece of Cake" signed "Estelle"; and seven final draft scripts for the episodes "A Midwinter Night's Dream," "Diamond in the Rough," "The Stan Who Came to Dinner," and "The Actor." The scripts are labeled and marked for Getty with highlighting. This lot exhibits minor creases from handling and minor stains. Dimensions: (each) 8.5" x 11" x 0.5" (21.75 cm x 28 cm x 1.5 cm)

**Estimate: \$2,000 - 4,000**



**845**  
 Rich Weaver Collection: One Estelle Getty-Signed  
 Script with Seven Additional Personal Scripts  
**The Golden Girls (1985-1992)**

One Estelle Getty-signed script with seven additional personal scripts from the comedy-drama series *The Golden Girls*. This lot comes from the collection of Estelle Getty's personal assistant and friend, Rich Weaver. It consists of one final draft script for Season 3's "Three on a Couch" signed "Estelle"; and seven final draft scripts including "The President's Coming! The President's Coming! Part One," "The President's Coming! The President's Coming! Part Two," and "Once, in St. Olaf." The scripts are labeled and marked for Getty with highlighting. This lot exhibits minor creases from handling and minor stains. Dimensions: (each) 8.5" x 11" x 0.25" (21.75 cm x 28 cm x 0.75 cm)

**Estimate: \$2,000 - 4,000**



**847**  
 Rich Weaver Collection: One Estelle Getty-Signed  
 Script with Seven Additional Personal Scripts  
**The Golden Girls (1985-1992)**

One Estelle Getty-signed script with seven additional personal scripts from the comedy-drama series *The Golden Girls*. This lot comes from the collection of Estelle Getty's personal assistant and friend, Rich Weaver. It consists of one final draft script for Season 2's "Son-In-Law Dearest" signed "Estelle"; and seven final draft scripts for the episodes "Love Under the Big Top," "Love, Rose," "Family Affair," "Rose Fights Back," "Not Another Monday," "That Old Feeling," and "Dancing in the Dark." The scripts are labeled and marked for Getty with highlighting. This lot exhibits minor creases from handling and minor stains. Dimensions: (each) 8.5" x 11" x 0.5" (21.75 cm x 28 cm x 1.5 cm)

**Estimate: \$2,000 - 4,000**



**846**  
 Rich Weaver Collection: One Estelle Getty-Signed  
 Script with Seven Additional Personal Scripts  
**The Golden Girls (1985-1992)**

One Estelle Getty-signed script with seven additional personal scripts from the comedy-drama series *The Golden Girls*. This lot comes from the collection of Estelle Getty's personal assistant and friend, Rich Weaver. It consists of one final draft script for Season 6's "Snap Out of It" signed "Estelle"; and seven final draft scripts for the episodes including "The Monkey Show, Part I," "The Monkey Show, Part II," and "Girls Just Wanna Have Fun.. Before They Die." The scripts are labeled and marked for Getty with highlighting. This lot exhibits minor creases from handling and minor stains. Dimensions: (each) 8.5" x 11" x 0.5" (21.75 cm x 28 cm x 1.5 cm)

**Estimate: \$2,000 - 4,000**



**848**  
 Rich Weaver Collection: Three Estelle Getty-Signed  
 Scripts with Five Additional Personal Scripts  
**The Golden Girls (1985-1992)**

Three Estelle Getty-signed scripts with five additional personal scripts from the comedy-drama series *The Golden Girls*. This lot comes from the collection of Estelle Getty's personal assistant and friend, Rich Weaver. It consists of three final draft scripts: "Long Day's Journey Into Marinara," "In a Bed of Rose's," and "The Custody Battle" signed "Estelle"; and five final draft scripts. The scripts are labeled and marked for Getty with highlighting. This lot exhibits minor creases from handling, minor stains, and residue from a removed label on one. Dimensions: (each) 8.5" x 11" x 0.5" (21.75 cm x 28 cm x 1.5 cm)

**Estimate: \$2,000 - 4,000**



**849**  
 Rich Weaver Collection: One Estelle Getty-Signed Script with Seven Additional Personal Scripts  
**The Golden Girls (1985-1992)**

One Estelle Getty-signed script with seven additional personal scripts from the comedy-drama series The Golden Girls. This lot comes from the collection of Estelle Getty's personal assistant and friend, Rich Weaver. It consists of one final draft script for Season 2's "Forgive Me, Father" signed "Estelle"; and seven final draft scripts for the episodes "Great Expectations," "Have Yourself a Very Little Christmas," "Rose's Mother," "The Competition," "Clinton Avenue Memoirs," "Stan's Return," and "Nice and Easy." The scripts are labeled and marked for Getty with highlighting. This lot exhibits minor creases from handling and minor stains. Dimensions: (each) 8.5" x 11" x 0.25" (21.75 cm x 28 cm x 0.75 cm)

**Estimate: \$2,000 - 4,000**

**850**  
 Rich Weaver Collection: One Estelle Getty-Signed Script with Seven Additional Personal Scripts  
**The Golden Girls (1985-1992)**

One Estelle Getty-signed script with seven additional personal scripts from the comedy-drama series The Golden Girls. This lot comes from the collection of Estelle Getty's personal assistant and friend, Rich Weaver. It consists of one final draft script for Season 2's "Bedtime Story" signed "Estelle"; and seven additional final draft scripts for the episodes "Triple Play," "On Golden Girls," "Mary Has a Little Lamb," "An Illegitimate Concern," "The Triangle," "That Was No Lady...," and "Love For Sale." The scripts are labeled and marked for Getty with highlighting. This lot exhibits minor creases from handling and minor stains. Dimensions: (each) 8.5" x 11" x 0.5" (21.75 cm x 28 cm x 1.5 cm)

**Estimate: \$2,000 - 4,000**



**851**  
 Rich Weaver Collection:  
 Queen Mother 1988 Birthday Ephemera  
**Royal Performance**

A set of 1988 ephemera including Estelle Getty's invitation from the Golden Girls' cast performance at the Royal Variety Performance for The Queen Mother Elizabeth's 90th birthday. This lot consists of two newsprint pages from the 24 November 1988 issue of The Stage and Television Today reporting on the event, two copies of the gloss paper invitation for the 21 November 1988 event, and a set of four Queen Mother stamps celebrating The Queen Mother Elizabeth's 90th birthday. The lot features discoloration, tears, creasing, and edge wear. Dimensions: (largest) 26.5 cm x 22.75 cm (67 cm x 57.75 cm)

**Estimate: \$300 - 600**



**852**  
 Rich Weaver Collection: Season 1 DVD Set with  
 Eight Final Draft Scripts and Cast List  
**The Golden Girls (1985-1992)**

A Season 1 DVD set, eight final draft scripts, and a cast list from the comedy series The Golden Girls. This lot comes from the collection of Estelle Getty's assistant and friend, Rich Weaver. It features an unused Season 1 DVD box set; eight final draft scripts labeled for Getty; and a one-page cast list featuring the Golden Girls' contact information. Season 2's "Sisters" is autographed by Getty and features highlighted annotations. This lot exhibits edge wear and bent corners to the scripts and discoloration on the cast list. Dimensions: 12.75" x 9.75" x 4.5" (32.5 cm x 24.75 cm x 11.5 cm)

**Estimate: \$800 - 1,600**

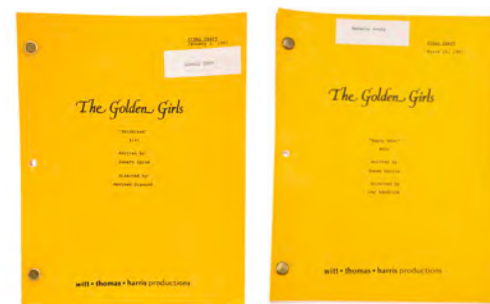

**853**  
 Rich Weaver Collection: Two Estelle  
 Getty-Signed Scripts with Six  
 Additional Personal Scripts  
**The Golden Girls (1985-1992)**

Two Estelle Getty-signed scripts with six additional personal scripts from the comedy-drama series The Golden Girls. This lot comes from the collection of Estelle Getty's personal assistant and friend, Rich Weaver, and consists of two final draft scripts for the Season 3 episode "Blanche's Little Girl" (featuring highlighter annotations) and the Season 6 episode "Miles To Go," both labeled for Getty and signed "Estelle"; and six final draft scripts for the episodes "Melodrama," "Older and Wiser," "Bringing Up Baby," "Mister Terrific," "Rose's Big Adventure," and "Empty Nest," with five labeled for Getty and three featuring highlighted and handwritten annotations. This lot exhibits minor fold creases from handling and minor stains. Dimensions (each): 8.5" x 11" x 0.25" (21.75 cm x 28 cm x 0.75 cm)

**Estimate: \$2,500 - 5,000**

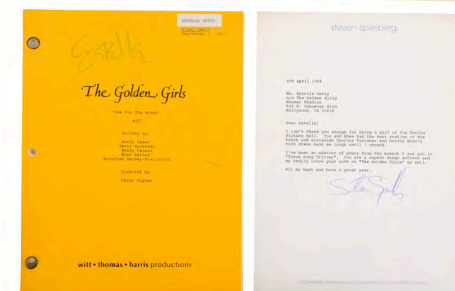

**854**  
 Rich Weaver Collection:  
 Set of Three Estelle  
 Getty-Autographed Scripts with  
 Steven Spielberg Signed Letter  
**The Golden Girls (1985-1992)**

Three Estelle Getty-autographed scripts with a Steven Spielberg signed letter from the comedy series The Golden Girls. This lot comes from the collection of Getty's assistant and friend, Rich Weaver, and consists of one script from Season 3's "One for the Money"; one from Season 4's "Yokel Hero"; one Season 4 script "Bang the Drum Stanley"; and a letter to Getty from Steven Spielberg, signed in blue ink on personal letterhead. Each script is a final draft labeled "ESTELLE GETTY," features Getty's autograph, and highlighted annotations. This lot exhibits minor discoloration and page creases. Dimensions: 8.5" x 11" x 0.25" (21.75 cm x 28 cm x 0.75 cm)

**Estimate: \$800 - 1,600**



**855**  
 Rich Weaver Collection: Melvin P.  
 Thorpe's (Dom DeLuise) Costume  
**The Best Little Whorehouse  
 In Texas (1982)**

Melvin P. Thorpe's (Dom DeLuise) costume from Colin Higgins' musical-comedy film The Best Little Whorehouse in Texas. Thorpe wore his costume during his report at City Hall. This lot comes from the collection of Estelle Getty's personal assistant and friend, Rich Weaver, and consists of a blue striped polyester-blend shirt with white embroidery and silver-color buttons labeled "2699-3 Dom DeLuise Collar 17 1/2"; matching stirrup trousers labeled "2699-3 Dom DeLuise 38 1/2 28 1/2"; a widescreen DVD; and a production tag. Included are two color photos of DeLuise's costume and a 2003 postcard from his cooking show autographed by him. Dimensions: 5.5" x 7.5" x 0.5" (14 cm x 19 cm x 1.5 cm)

**Estimate: \$1,000 - 2,000**



**856**  
**Rich Weaver Collection: Betty White's Christmas Sweater, "Rose Nyland" Autographed Note, Five Scripts, Cast Photo, and Magazine**  
**Betty White**

Betty White's Christmas sweater, "Rose Nyland" autographed note, five scripts, a cast photo, and a magazine. White wore her Christmas sweater in a 1995 Entertainment Tonight clip to remember White as an animal advocate where she showcased her story of a potential career with animals if she wasn't an actor while she fed a giraffe. This lot comes from the collection of Estelle Getty's personal assistant and friend, Rich Weaver, and consists of a farm-themed cotton blend Marris Christina Classics "The Christmas Collection 1992" knit Christmas sweater featuring gold-color metal bells, red and yellow bows originally made, but unseen, for The Golden Girls; and a White-autographed note identifying herself as "Rose Nyland" from Golden Girls, five final draft Golden Girls scripts (three of which are labeled for Estelle Getty) for the episodes "The Bloom is Off the Rose," "Where's Charlie?," "Joust Between Friends," "Rose the Prude," and "Blind Ambitions"; one black-and-white cast photo of White, Getty, and Rue McClanahan; and a copy of Bets' Pets Roundup 1997 25th Anniversary Issue. This lot exhibits minor loose threads and tags. Dimensions (scripts): 8.5" x 11" x 0.5" (21.75 cm x 28 cm x 1.5 cm)

**Estimate: \$2,000 - 4,000**

**858**  
**Rich Weaver Collection: The Thalians 1987 Gala Ball Dress and Ephemera**  
**Debbie Reynolds**

The Thalians 1987 gala ball dress and ephemera relating to actress and singer Debbie Reynolds, who wore this ensemble to perform at the charity event. This lot comes from the collection of Estelle Getty's personal assistant and friend, Rich Weaver, and features a black lace zip-back V-neck dress features black sequins, faux crystals, feathers, a black silk-blend lining and a sewn-in diamond metal necklace, all accompanied by a matching hat with ostrich feathers. Included are two 4" x 6" black-and-white photos from the event, a printed document with background information on the dress, sheet music, and a Thalians ball pop-up card, program, and catalog. The dress exhibits minimal wear, snagging, and minor discolorations; the sheet music exhibits staining, creasing, and cracking; and the ephemera exhibits minor edgewear.



**Estimate: \$1,000 - 2,000**

**857**  
**Rich Weaver Collection: Myrna Burwell's (Estelle Getty) Racing Jumpsuit with "Motherly Love" Scripts**  
**Brotherly Love (1995-1997)**

Myrna Burwell's (Estelle Getty) "Motherly Love" racing jumpsuit with scripts from Jonathan Schmock and Jim Vallely's sitcom Brotherly Love. Burwell participated in and won a contentious box car race. This lot comes from the collection of Estelle Getty's personal assistant and friend, Rich Weaver and features a red and orange poly-cotton jumpsuit with elastic cuffs and various competition and team patches; and two scripts from September 1996 that include: a pink and purple 67-page script labeled "Joe Lawrence" with handwritten notes, and a yellow bound 56-page script featuring handwritten annotations and pink highlights. The jumpsuit exhibits loose threads, patch edgewear, and collar fraying; the scripts exhibit edgewear, staining, and notable liquid damage. Dimensions: 8.5" x 11" (21.5 cm x 28 cm)



**Estimate: \$1,000 - 2,000**



**859**  
**Rich Weaver Collection: Various Dolly Parton Ephemera**  
**Dolly Parton**

Ephemera from Dolly Parton's musical career. This lot comes from the collection of Estelle Getty's personal assistant and friend, Rich Weaver, and consists of two "Dolly Parton...Home for Christmas" first draft scripts, one annotated; a 1987 T.V. Guide with Dolly on the cover; 54 color photos of Dolly with soldiers and from performances; a billing statement from dress designer Tony Chase; a 1992 Dolly Parton Tour Buena Vista Pictures Marketing memorandum; a 1987 "Dolly" final draft script; A Dollywood Smoky Mountain Christmas brochure from 1993; and three hand-drawn Tony Chase dress designs, two with fabric swatches. This lot exhibits minor stains, tears, and discoloration. Dimensions: 12" x 17.5" (30.5 cm x 44.5 cm) Sold without copyright; see notice in the Buyer's Guide.

**Estimate: \$600 - 1,200**

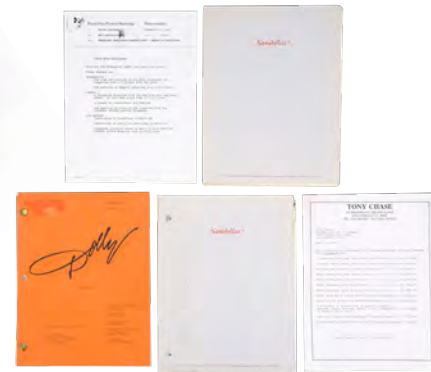

**860**  
**Rich Weaver Collection: Estelle Getty's Personal Director's Chair, Crew Jacket, and Seven Scripts**  
**Empty Nest (1988-1995)**

Estelle Getty's personal director's chair, crew jacket, and seven scripts from the comedy-drama television series Empty Nest. Getty kept this chair at home in her TV room and used it when she watched episodes of "The Golden Girls" and other series. This lot comes from the collection of Estelle Getty's personal assistant and friend, Rich Weaver, and includes one director's chair with a wooden frame, a blue canvas seat, and a blue canvas chairback labeled "Estelle Getty"; a brown leather and black wool crew jacket featuring the series title and the name "Estelle"; and seven final draft scripts from the Season 6 episodes "Bye-Bye, Baby...Hello Part One," "Bye-Bye, Baby...Hello Part Two," "Mom's The Word," "Half That Jazz," "Lordy, Lordy, Landlordy," "Best Friends," and "Absence Makes The Nurse Grow Weirder." These scripts feature various revision pages on colored paper, include shooting schedules, some handwritten notes and annotations, and are printed on recycled paper. Also included are two cast and crew photos from the series. The script exhibits minor stains and fold creases along the edges, the chairback exhibits minor stains as well. Dimensions (chair): 27" x 16.25" x 9" (68.75 cm x 41.5 cm x 23 cm)

**Estimate: \$1,500 - 3,000**



**862**  
**Rich Weaver Collection: Set of Five Scripts, Photo Album, and Crew Robe**  
**Empty Nest (1988-1995)**

Five scripts, a photo album, and a crew robe from the comedy series Empty Nest. This lot comes from the collection of Estelle Getty's personal assistant and friend, Rich Weaver, and consists of five final draft scripts from the episodes "The Girl Who Cried Baby," "Mama Todd The Sequel," "Under the Gun," "Mommy and Me," and "Superbaby"; a 12-page photo album embossed "Empty Nest Memories" dated March 28, 1988 to March 21, 1995 of the cast with the covers from the pilot script dated March 28, 1988 and the final script "Remembrance of Clips Past" dated March 17, 1995; and a white terry cloth crew robe featuring "Empty Nest" embroidered in red on the back. This lot exhibits worn material to the photo album cover. Dimensions: 20" x 20" x 6" (51 cm x 51 cm x 15.25 cm)

**Estimate: \$1,000 - 2,000**

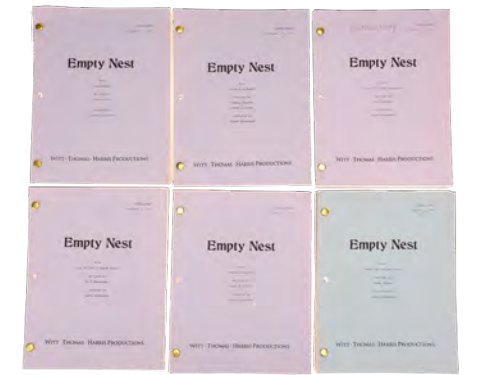

**861**  
**Rich Weaver Collection: Set of Estelle Getty's Bound Scripts and a Handwritten Note from Richard Mulligan**  
**Empty Nest (1988-1995)**

A set of Estelle Getty's bound scripts from the sixth season of the comedy series Empty Nest. This lot comes from the collection of Estelle Getty's personal assistant and friend, Rich Weaver, and consists of six brass-brad bound final draft scripts for the episodes "When the Rooster Dies," "Diary of a Mad Housewife," "Mother Dearest," "Love a la Mode," "Gesundheit," and "The Ballad of Shady Pines." Also included is one handwritten note from Richard Mulligan. This lot exhibits minor discoloration and edgewear from age. Dimensions: (each) 8.5" x 11" x 0.25" (21.75 cm x 28 cm x 0.75 cm)

**Estimate: \$1,000 - 2,000**

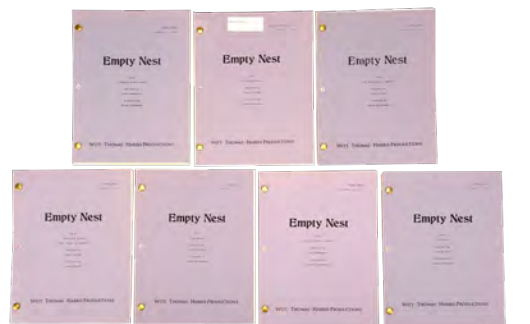

**863**  
**Rich Weaver Collection: Set of Estelle Getty's Scripts**  
**Empty Nest (1988-1995)**

A set of Estelle Getty's bound scripts from the sixth season of the comedy series Empty Nest. This lot comes from the collection of Estelle Getty's personal assistant and friend, Rich Weaver, and consists of seven brass-brad bound final draft scripts for the episodes "No Volunteers, Please," "Das Boob," "Brotherly Shove," "Hog Heaven," "Charley's Millions," "A Foreign Affair," and "The Devil and Dr. Westen." This lot exhibits minor discoloration and edgewear from age. Dimensions: (each) 8.5" x 11" x 0.25" (21.75 cm x 28 cm x 0.75 cm)

**Estimate: \$800 - 1,600**

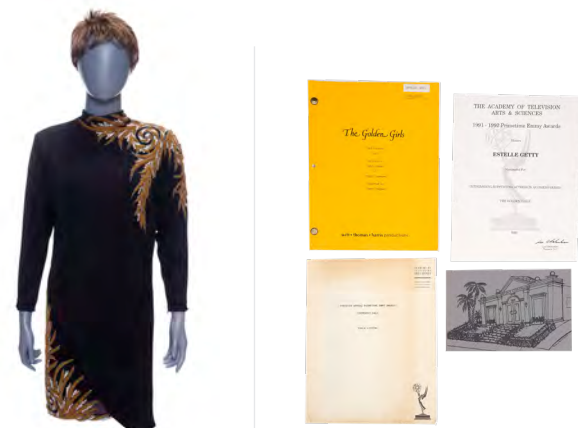

**864**  
Rich Weaver Collection: Estelle Getty's 1992 Emmy Awards® Memorabilia with Personal Script **The Golden Girls (1985-1992)**

Estelle Getty's 1992 Emmy Awards® memorabilia and a script from the comedy series The Golden Girls. Getty won Outstanding Supporting Actress in a Comedy Series at the 1992 Emmy Awards®. This lot comes from the collection of Estelle Getty's personal assistant and friend, Rich Weaver. It consists of a black nylon and tulle underskirt dress with gold- and pearl-color sequins designed by costume designer Tony Chase; a brown synthetic hair wig; a color photo of Getty wearing her dress at the ceremony; Getty's Emmy Awards® Nominee Certificate; three packets of Emmy Awards® paperwork; a final draft script for the Season 3 episode "Old Friends" labeled for Getty; and a Tony Chase Design Studio moving card. The dress exhibits minor loose threads. Dimensions (script): 8.5" x 11" (21.75 cm x 28 cm)

**Estimate: \$2,000 - 4,000**



**865**  
Rich Weaver Collection: Estelle Getty's Hand-Painted Disney Animation Cel and Disney Ephemera **The Golden Girls (1985-1992)**

Estelle Getty's hand-painted Disney animation cel and additional ephemera from Walt Disney Studios. Disney sent Getty a personalized cel to congratulate her for receiving a Golden Globe® for Best Actress for her performance in The Golden Girls. This lot comes from the collection of Estelle Getty's personal assistant and friend, Rich Weaver. It consists of a hand-painted cel of Getty and Mickey Mouse in a black-painted wooden frame; a folder labeled "Estelle Getty" featuring Mickey with Getty's award signed by Rich Frank and Jeffrey Katzenberg; a Walt Disney Studios letter; three photos of Getty; and "The Wonderful World of Disney Television A Complete History" autographed by Bill Cotter. This lot exhibits chipping and page creasing. Dimensions: 23" x 21.5" x 0.5" (58.5 cm x 54.75 cm x 1.25 cm) Sold without copyright; see copyright notice in the Buyer's Guide.

**Estimate: \$1,500 - 3,000**



**868**  
Rich Weaver Collection: Estelle Getty's Senior Yearbook and Autographed Scripts **Estelle Getty**

Estelle Getty's senior yearbook from Seward Park High School and autographed scripts from the comedy series The Golden Girls. This lot comes from the collection of Estelle Getty's personal assistant and friend, Rich Weaver. It consists of a beige and blue hardcover 56-page 1941 "The Almanac" senior yearbook featuring Getty as her maiden self Estelle Scher; and three final draft scripts. Two scripts are autographed "Estelle" and one has a printed label for Getty. This lot exhibits stains and discolorations. Dimensions (largest): 8" x 11" x 0.5" (20.5 cm x 28 cm x 1.5 cm)

**Estimate: \$800 - 1,600**



**869**  
Rich Weaver Collection: Set of Estelle Getty's Personal Cards with Signed Scripts **Estelle Getty**

A set of Estelle Getty's personal cards from various organizations and signed scripts from the comedy series The Golden Girls. This lot comes from the collection of Estelle Getty's personal assistant and friend, Rich Weaver, and consists of one health services card to Saint John's Hospital and Health Center; one Citibank credit card; one AAA Automobile Club card; one Screen Actors Guild card, two Screen Actors Guild Producers Health Plan cards, one American Federation of Television and Radio Artists card, one Actors' Equity Association card, one revised final draft script for the episode "Job Hunting," one final draft script for the episode "High Anxiety," one final draft script for the episode "Fiddler on the Ropes," and final draft scripts for "Sick and Tired" Part I and Part II. Three scripts are signed "Estelle" by hand and two solely have a printed label for Getty. The cards exhibit fading ink, stains, and warping. Dimensions (scripts): 8.5" x 11" x 0.5" (21.75 cm x 28 cm x 1.5 cm)

**Estimate: \$800 - 1,600**



**866**  
Rich Weaver Collection: Estelle Getty's Award Certificates and Los Angeles Birthday Declaration **Estelle Getty**

Estelle Getty's award certificates from various organizations and birthday declaration from the City of Los Angeles. Getty received awards and nominations for her work as an actress and for The Golden Girls. This lot comes from the collection of Estelle Getty's personal assistant and friend, Rich Weaver. It consists of six award certificates addressed to Getty; two award certificates addressed to The Golden Girls; ephemera from the American Comedy Honors; and a matted and framed 75th birthday declaration from the president of the Los Angeles City Council John Ferraro. This lot exhibits minor grime and discoloration. Dimensions: 18" x 21.5" x 1" (45.75 cm x 54.75 cm x 2.75 cm)

**Estimate: \$1,000 - 2,000**



**867**  
Estelle Getty's Driver's License and SAG Card **Estelle Getty**

Estelle Getty's personal California Driver's License featuring a picture of Getty numbered "C5697947," as well as her Screen Actors Guild card with membership number "0053553." Both of these cards have expired and the SAG card exhibits tape residue and bending. Dimensions: (each) 3.5" x 2.5" (8.75 cm x 6 cm)

**Estimate: \$800 - 1,600**



**870**  
Rich Weaver Collection: Set of Personal Letters and Cards Addressed to Estelle Getty and One Photo **Estelle Getty**

A set of personal letters and cards and one photo addressed to Estelle Getty. This lot comes from the collection of Estelle Getty's assistant and friend, Rich Weaver. It consists of one color photo featuring actress Betty White and 31 handwritten and printed letters and cards from various production studios, former president Bill Clinton, letters of appreciation and gratitude, and birthday wishes. The lot exhibits minor edge wear and discoloration. Dimensions: 8.5" x 11" (21.75 cm x 28 cm)

**Estimate: \$1,000 - 2,000**



**871**  
Rich Weaver Collection: Set of Six Headshots, Set of Six Scripts, and Credits **Estelle Getty**

Six Estelle Getty headshots, six scripts, and a credit list for casting directors. Headshots and credits lists were received and reviewed by casting directors for film and television productions. This lot consists of six black-and-white glossy photos of Getty: four headshots, and 2 featuring her headshot with photos of various character looks at the left and bottom margins. Stapled to the back of one headshot is a printed list of credits, noting her work on The Golden Girls series and the Sylvester Stallone film Stop! Or My Mom Will Shoot. Accompanying the lot are three scripts from the comedy series The Golden Girls, one script from the spin-off series The Golden Palace, one script from Empty Nest, and one script from the film Mannequin. This lot exhibits edge wear, bent corners, and creasing. Dimensions: 8.5" x 11" (21.5 cm x 28 cm)

**Estimate: \$800 - 1,600**



**872**  
 Rich Weaver Collection: Sophia's (Estelle Getty)  
 Embroidered Slippers and Robe with  
 Seven Personal Scripts  
**The Golden Palace (1992-1993)**

Sophia's (Estelle Getty) embroidered slippers and robe with seven personal scripts from the comedy series The Golden Palace. Getty wore her robe and slippers while on set. This lot comes from the collection of Estelle Getty's personal assistant and friend, Rich Weaver, and consists of a white terry cloth robe featuring "Sophia" and "The Golden Palace" in gold-color embroidery; white terry cloth heeled slippers with "Sophia" embroidered in gold-color thread; and seven final draft scripts labeled "Estelle Getty (collated)," including scripts for "Seems Like Old Times Part I" and "Seems Like Old Times Part II." This lot exhibits minor discoloration. Dimensions: 8.5" x 11" x 0.5" (21.75 cm x 28 cm x 1.5 cm)

**Estimate: \$1,000 - 2,000**

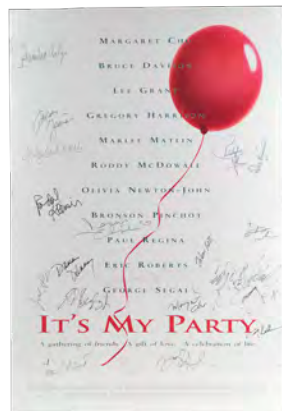

**874**  
 Rich Weaver Collection: Autographed Movie Poster  
**It's My Party (1996)**

An autographed movie poster from Randal Kleiser's romantic drama It's My Party. This poster on foam poster board depicts a red balloon. The poster comes from the collection of Estelle Getty's assistant and friend, Rich Weaver, autographed by director Randal Kleiser, cast members Marlee Matlin, Dennis Christopher, Gregory Harrison, Eric Roberts, Joel Polis, Salley Kellerman, Roddy McDowall, Dimitra Arliss, Bronson Pinchot, Margaret Cho, Lee Grant, Christopher Atkins, George Michael, Stephanie Zimbalist, Ed Begley Jr., Dana Delany, Daryl Hannah, and Jeff Conaway. This lot exhibits dents to the foam and minor scratches. Dimensions: 27" x 40" x 0.25" (68.75 cm x 101.75 cm x 0.75 cm)

**Estimate: \$600 - 1,200**



**873**  
 Rich Weaver Collection:  
 Set of 12 Estelle Getty's Bound Scripts  
**The Golden Palace (1992-1993)**

A set of 12 Estelle Getty's bound scripts from the comedy series The Golden Palace. This lot comes from the collection of Estelle Getty's personal assistant and friend, Rich Weaver, and consists of 12 brass-brad bound and hand-annotated scripts for the pilot, and the following episodes: "Promotional Considerations," "Ebbtide for the Defense," "Can't Stand Losing You," "Marriage on the Rocks, with a Twist," "It's Beginning to Look a Lot (Less) Like Christmas," "Rose and Fern," "Heartbreak Hotel," "Senior Stinky Learns Absolutely Nothing About Life," "Say Goodbye, Rose," "Tad," and "The Chicken and The Egg." This lot exhibits minor discoloration and edgewear from age. Dimensions: (each) 8.5" x 11" x 0.25" (21.75 cm x 28 cm x 0.75 cm)

**Estimate: \$1,000 - 2,000**



**875**  
 Rich Weaver Collection: Estelle Getty's Script,  
 Promotional Ephemera and a Cast and Crew  
 Autographed "Happy Birthday Estelle" Poster  
**Stop Or My Mom Will Shoot (1992)**

Estelle Getty's script, ephemera and cast and crew autographed "Happy Birthday Estelle" poster from Roger Spottiswoode's black comedy Stop! Or My Mom Will Shoot. This lot comes from the collection of Estelle Getty's personal assistant and friend, Rich Weaver. It consists of a gray plastic three-ring binder with 116-page script; an autographed "Happy Birthday Estelle" poster printed on white cardstock; a full-page newspaper advertisement; seven stapled PR packets and bios; eight black-and-white promotional photos; a behind-the-scenes photo of Getty; and a 110-page script copy with a red cardstock cover. The lot exhibits staining, edge wear, tearing and creasing. Dimensions: (poster) 28" x 44" (71.5 cm x 112 cm)

**Estimate: \$1,500 - 3,000**



**876**  
 Rich Weaver Collection: Aunt Estelle's  
 (Estelle Getty) Screen-Matched Costume  
**Stuart Little (1999)**

Aunt Estelle's (Estelle Getty) screen-matched costume from Rob Minkoff's family comedy Stuart Little. The patterns on this dress screen-match the costume to the one Aunt Estelle wore during Stuart (Michael J. Fox) and George Little's (Jonathan Lipnicki) boat race victory celebration. This lot comes from the collection of Estelle Getty's personal assistant and friend, Rich Weaver. It consists of a beige and blue floral polyester dress with pink embroidered flowers along the collar and cuffs; nine blue floral and two beige spare buttons; spare floral trim; and an extra off-white collar. Also included is a movie still printed on paper. This lot exhibits fraying material on the spare floral embroidery.

**Estimate: \$1,000 - 2,000**



**878**  
 Pirate Treasure Coin  
**The Goonies (1985)/Hook (1991)**

A pirate treasure coin from Richard Donner's adventure film The Goonies. Gold coins filled One-Eyed Willy's vast treasure hoard on the Inferno. Many of the coins were later reused in Steven Spielberg's film Hook. This uneven metal coin is hand-painted gold-color and engraved with cross patterns and bars on opposite sides. It exhibits some flaking to the paint and exposed silver-color metal underneath from production use and exposure. Dimensions: 1.5" x 1.5" x 0.25" (3.5 cm x 3.5 cm x 3.5 cm)

**Estimate: \$1,000 - 2,000**



**877**  
 Pair of Hand-Drawn Concept Sketches  
**The Goonies (1985)**

A pair of hand-drawn concept sketches from the production of Richard Donner's family adventure film The Goonies. The Goonies met and befriended Sloth (John Matuszak) while they searched for the hidden fortune of long-dead pirate One-Eyed Willy. The two hand-drawn concept illustrations are rendered in multicolor pastels on black paper. The sketches were done as part of the visual effects design work for the film and depict Sloth watching television and the Goonies in the Moss Garden Wishing Well. Both exhibit some smudges and bent edges to the paper. Dimensions: (each) 16.25" x 6.75" (41 cm x 17 cm) Sold without copyright; see notice in the Buyers Guide.

**Estimate: \$600 - 1,200**



**879**  
 Trans-Alpine Yodel Newspaper Cover  
**The Grand Budapest Hotel (2014)**

A Trans-Alpine Yodel newspaper cover from Wes Anderson's comedy film The Grand Budapest Hotel. Zero (Tony Revolori) showed Gustave (Ralph Fiennes) the news of Madame D.'s (Tilda Swinton) death. This lot consists of one newspaper cover. Printed on a newsprint, it features front and back covers with blank pages inside. The newspaper, dated "Monday, October 13, 1932," is a "Morning Edition" featuring the headline "Will There Be War? - Tanks at Frontier" with a small article on the death of the Dowager with an accompanying photo. This lot exhibits a prominent fold line, mild discoloration, and wear along the edges. Dimensions: 13" x 9.5" (33 cm x 24.25 cm)

**Estimate: \$1,000 - 2,000**



**880**  
Paul Edgecomb's (Tom Hanks) Pajama Bottoms  
**The Green Mile (1999)**

Paul Edgecomb's (Tom Hanks) pajama bottoms from Frank Darabont's fantasy-drama film *The Green Mile*. Edgecomb wore his pajama bottoms as he frantically ran to his outhouse to relieve himself with a discomfiting urinary tract infection. This lot consists of a pair of blue cloth thin plaid pajama bottoms (size Large) featuring a drawstring waistband, a straight leg fit, and one production tag. This lot exhibits a loose waistband.

**Estimate: \$1,000 - 2,000**



**881**  
Dismembered Gremlin Puppet Arms  
**Gremlins 2: The New Batch (1990)**

A pair of dismembered Gremlin arms from Jon Dante's black comedy horror sequel *Gremlins 2: The New Batch*. When a mob of Gremlins attacked Kate Peltzer through the elevator walls, it dropped and dismembered them. Designed by Rick Baker's team at Cinovation, these foam latex Gremlin arms are applied around rubber tubes and an interior metal armature. They include puppet cables and trigger mechanisms which control their hand movements. The foam latex is hand-painted in shades of green, brown, yellow, and red. They feature scales, veins, and rubber claws on each finger. The fingers and wrists on each piece exhibit cracks, splits, and dryness in the foam latex from age. Dimensions: (longest extended flat) 95" x 10" x 2.75" (241 cm x 25 cm x 7 cm). Contains mechanical components; see notice in the Buyer's Guide.

**Estimate: \$2,500 - 5,000**



**882**  
Murray Futterman's (Dick Miller) Jacket  
**Gremlins 2: The New Batch (1990)**

Murray Futterman's (Dick Miller) jacket from Joe Dante's horror comedy *Gremlins 2: The New Batch*. Futterman wore his jacket throughout the film as he helped Billy Peltzer (Zach Galligan) defeat the gremlins. This lot consists of a light khaki jacket. The jacket features front pockets and button closures, as well as a quilted design on the upper right shoulder. The jacket also includes a matching belt with a red buckle. This jacket exhibits missing buttons and loose threads from production.

**Estimate: \$1,000 - 2,000**



**883**  
Laurie Strode's (Scout Taylor-Compton) Bloodied Rocky Horror Picture Show Costume  
**Halloween II (2009)**

Laurie Strode's (Scout Taylor-Compton) bloodied Rocky Horror Picture Show costume from Rob Zombie's slasher film *Halloween II*. Strode wore her Rocky Horror Picture Show costume during *Halloween* and it became increasingly bloodied during the final confrontation with Michael Myers (Tyler Mane). This costume consists of a polyester black mini dress with a white pointed collar and a white cuff hem on the 3/4 sleeves, as well as a linen apron. The apron's straps button to the tie on the tie-back. Production intentionally distressed this costume to appear torn, dusty, and bloodied from the fight. This costume exhibits some discoloration and frayed fibers.

**Estimate: \$1,000 - 2,000**



**884**  
Deborah Myers' (Sheri Moon Zombie) Ghost Costume  
**Halloween II (2009)**

Deborah Myers' (Sheri Moon Zombie) ghost costume from Rob Zombie's slasher film *Halloween II*. In the final confrontation between Myers (Tyler Mane) and Laurie (Scout Taylor-Compton), Deborah appeared in her costume with Young Myers (Chase Vanek). This costume consists of one dress. Made of cream-color chiffon lined with polyester, this dress features a plunging neckline, draped sleeves, a full skirt with chiffon gussets, and a train. The dress has a hidden side zip and a hook-and-eye closure at the neck. This dress exhibits some discoloration, frayed fibers, and a hole in the lining of the skirt.

**Estimate: \$3,000 - 6,000**



**885**  
Young Michael Myers' (Chase Wright Vanek) Clown Costume  
**Halloween II (2009)**

Young Michael Myers' (Chase Wright Vanek) clown costume from Rob Zombie's slasher film *Halloween II*. In the final confrontation between Myers (Tyler Mane) and Laurie (Scout Taylor-Compton), young Myers appeared in his costume with Deborah Myers (Sheri Moon Zombie). This costume consists of a polyester slip-on jumpsuit. Featuring a tie at the back of the neck and short sleeves, this costume consists of blue and yellow legs, a red and golden-rod colored top with polka dot and fringe patterns, as well as a clown graphic on the front. This costume exhibits some fading of the graphic print on the jumpsuit and snapped threads.

**Estimate: \$1,500 - 3,000**





**886**  
Silverbeard's (Peter Elliott)  
Mechanical Ape Glove  
**Greystoke: The Legend Of Tarzan,  
Lord Of The Apes (1984)**

Silverbeard's (Peter Elliott) mechanical ape glove from Hugh Hudson's adventure film Greystoke: The Legend of Tarzan, Lord of the Apes. Silverbeard became Tarzan's (Christopher Lambert) primate father after his real parents died in the African jungle. Created by primate costume designer Rick Baker, this glove features jointed metal and plastic fingers connected to a fiberglass palm hand-labeled "-Ter -Liott" under brown-skinned foam residue. Its fingers open and close via a threaded pulley cord. The glove exhibits extensive cracking and missing foam, fraying cord, and some rust from production use and age. Contains mechanical components; see notice in the Buyer's Guide.

**Estimate: \$800 - 1,600**

**887**  
Cast-Autographed Hogwarts  
Acceptance Envelope  
**Harry Potter And The  
Sorcerer's Stone (2001)**

A cast-autographed Hogwarts acceptance envelope from Chris Columbus' fantasy adventure Harry Potter and the Sorcerer's Stone. Hundreds of envelopes containing acceptance letters flew down the Dursley family's chimney to reach Harry Potter (Daniel Radcliffe). The cream-color envelope has Potter's (Daniel Radcliffe) address printed in green on the front, with a faux wax seal and the Hogwarts crest printed on the back. The envelope is autographed in black pen by Radcliffe, Rupert Grint (Ron Weasley), and Tom Felton (Draco Malfoy). Dimensions: 5.25" x 7.25" (13.5 cm x 18.5 cm)

**Estimate: \$3,500 - 7,000**

**888**  
Daniel Radcliffe and Cast-  
Autographed Call Sheet  
**Harry Potter And The  
Sorcerer's Stone (2001)**

A Daniel Radcliffe and cast-autographed call sheet from the production of Chris Columbus' fantasy-adventure film Harry Potter and the Sorcerer's Stone. Dated "Friday 17th November 2000", this document is titled "Callsheet: 36" and concerns the external scenes set in the Dark Forest. It features a list of scheduled screen tests and call times for key cast members and doubles, and is autographed in black ink by the film's three stars, Daniel Radcliffe (Harry Potter), Rupert Grint (Ron Weasley) and Emma Watson (Hermione Granger). The sheet exhibits minor wear along the top edge. Dimensions: 11.75" x 8.25" (30 cm x 21 cm)

**Estimate: \$1,200 - 2,400**

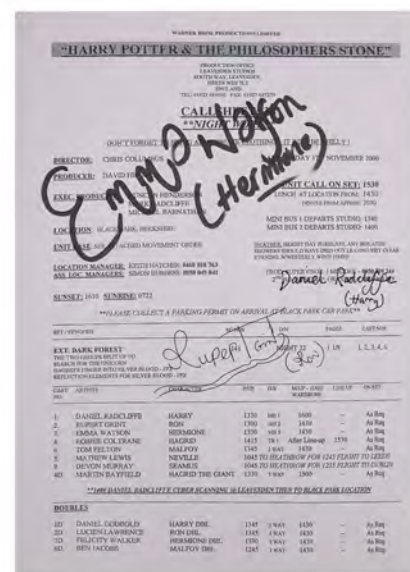
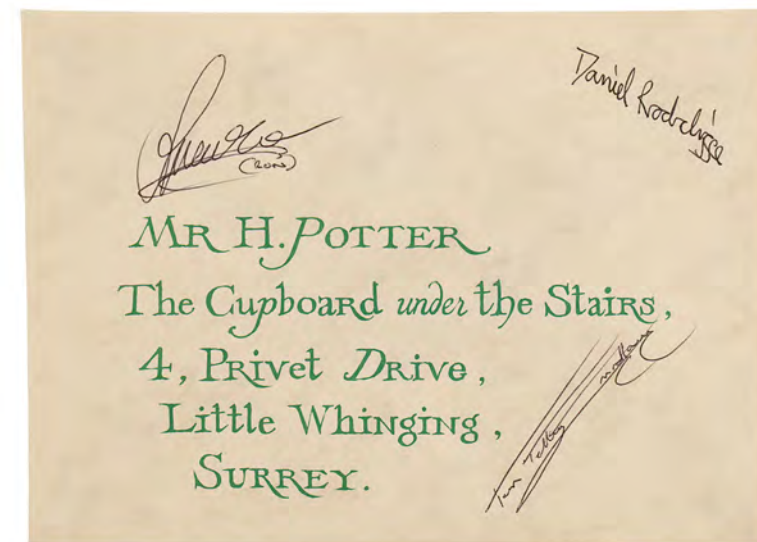

**889**  
Set of Five Hand-Drawn Doug Brode  
Harry Potter Concept Illustrations  
**Harry Potter And The Prisoner Of Azkaban (2004)**

A set of five Harry Potter concept illustrations hand-drawn by Doug Brode for the promotion of Alfonso Cuaron's fantasy sequel Harry Potter and the Prisoner of Azkaban. Warner Bros. had key sequences from the film drawn for licensing purposes to be used as promotional material. These concept illustrations depicting Harry in a quidditch match, fighting Boggarts, and exploring Hogwarts' corridors are rendered in pencil and ink on paper signed by Brode. Various annotations are handwritten throughout their margins. This set exhibits minor discoloration and wrinkles throughout. Dimensions: (each) 11" x 17" (28 cm x 43.25 cm) Sold without copyright; see notice in the Buyer's Guide.

**Estimate: \$1,000 - 2,000**



**891**  
Set of Four Hand-Drawn Doug  
Brode Harry Potter Concept Illustrations  
**Harry Potter And The Prisoner Of Azkaban (2004)**

A set of four Harry Potter concept illustrations hand-drawn by Doug Brode for the promotion of Alfonso Cuaron's fantasy sequel Harry Potter and the Prisoner of Azkaban. Warner Bros. had key sequences from the film drawn for licensing purposes for use as promotional material. These concept illustrations depicting Harry with Ron Weasley and Hermione Granger and fighting Dementors are rendered in pencil and ink on paper signed by Brode. This set exhibits minor discoloration, tape residue, and wrinkles throughout. Dimensions: (each) 11" x 17" (28 cm x 43.25 cm) Sold without copyright; see notice in the Buyer's Guide.

**Estimate: \$1,000 - 2,000**



**890**  
Five Hand-Drawn Doug Brode Harry Potter  
Dementors and Willow Concept Illustrations  
**Harry Potter And The Prisoner Of Azkaban (2004)**

Five Harry Potter concept illustrations hand-drawn by Doug Brode for the promotion of Alfonso Cuaron's fantasy sequel Harry Potter and the Prisoner of Azkaban. Warner Bros. had film sequences drawn for licensing purposes for use as promotional material. These concept illustrations depicting Harry with the Whomping Willow tree and fighting Dementors are rendered in pencil and ink on paper signed by Brode. Annotations are handwritten throughout their margins. This set exhibits minor discoloration, tape residue, and wrinkles throughout. Dimensions: 16.5" x 13.5" (42 cm x 34.5 cm) Sold without copyright; see notice in the Buyer's Guide.

**Estimate: \$1,000 - 2,000**

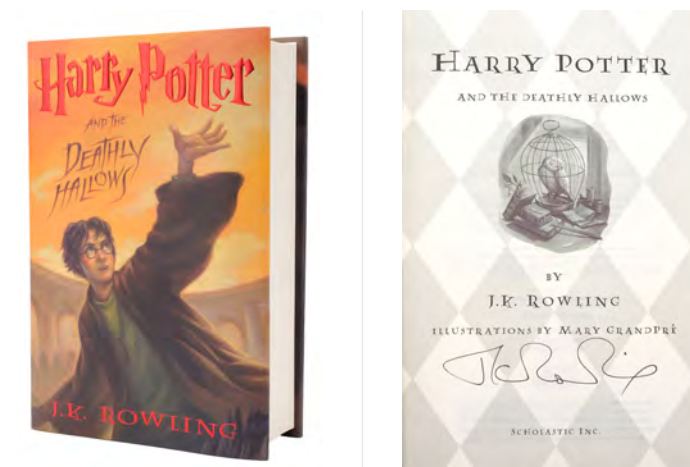

**892**  
J.K. Rowling-Signed Hardcover Edition of  
"Harry Potter and The Deathly Hallows" Δ  
**Harry Potter Franchise (1997-2007)**

A hardcover edition of "Harry Potter and The Prisoner of Azkaban" signed by author J.K. Rowling. The final installment in the popular fantasy series, this book was part of a limited edition set of autographed copies of the Harry Potter books produced by Scholastic. This hardcover book includes a color-printed dust jacket featuring the iconic artwork of Mary GrandPre and is signed by Rowling on the interior title page in black ink. The book exhibits minimal signs of handling. Dimensions: 6.25" x 9.25" x 2.25" (16 cm x 23.5 cm x 5.75 cm)

**Estimate: \$1,000 - 2,000**



**893**  
Hellboy's (Ron Perlman) Neck and Chest Makeup Appliance  
**Hellboy (2004)**

Hellboy's (Ron Perlman) neck and chest makeup appliance from Guillermo del Toro's supernatural adventure Hellboy. Hellboy worked to save humanity from Rasputin (Karel Roden) throughout the film. Created by special effects director Rick Baker's Cinovation Studios, this sculpted foam latex makeup appliance is painted dark red to match Hellboy's devilish appearance and carved with lines. Also included is a black plastic bust for stability. The appliance exhibits some tearing around its edges and stiffening from production wear and age, and the base exhibits scuffing throughout.

**Estimate: \$1,200 - 2,400**



**894**  
Screen-Matched Animatronic Engineer Head  
**Hellraiser (1987)**

A screen-matched animatronic Engineer head from Clive Barker's horror film Hellraiser. The distinctive hand-painted eyes screen-match, particularly in close-up shots. This head, made by Bob Keen and his team at Image Animation, consists of a fiberglass skull with cat-like eyes, menacing yellowed sharp teeth, and a moveable lower jaw. The skull houses cables and radio-controlled servos. The majority of the foam-latex skin has worn away. The head remains fragile and exhibits discoloration, scuffing, and the lower jaw section has warped slightly over time. Dimensions: 11" x 9" x 17" (28 cm x 23 cm x 44 cm) Contains electronics and mechanical components; see notice in the Buyer's Guide.

**Estimate: \$3,500 - 7,000**



**895**  
Colin's (Adam Faison) Bloodied Costume  
**Hellraiser (2022)**

Colin's (Adam Faison) bloodied costume from David Bruckner's supernatural horror film Hellraiser. After being marked for a sacrifice, Colin was tortured by a Cenobite. This lot consists of a pair of glasses in a green velvet wrap; a metal silver-color hoop earring; a gray and beige wide-striped button-up shirt; a brown braided belt; blue jeans; gray athletic shoes; and a set of three connected faux wire coils. Also included are three certificates of authenticity from Spyglass Media Group. Production intentionally distressed this costume to appear bloody. This costume exhibits notable residue on the SFX blood, creases on the shoes with rocks in the treads, and fabric stiffness.

**Estimate: \$1,500 - 3,000**



**896**  
Hercules' (Kevin Sorbo) Costume  
**Hercules: The Legendary Journeys (1995-1999)**

Hercules' (Kevin Sorbo) costume from the action-adventure series Hercules: The Legendary Journeys. In the Season 5 episode "Render Unto Caesar," Hercules was given his costume from the Celts after he helped defend them from Julius Caesar (Karl Urban). This lot consists of brown suede trousers with stirrups; brown leather wrap boots with fastening strips marked "Herc Left" and "Herc Right"; fur-lined brown leather bracers with gold-color painted metal Celtic embellishments; a brown leather belt with gold-color painted resin Celtic embellishments; a brown wool tunic labeled "Hercules Kevin Sorbo"; and a brown leather and nylon-lined vest labeled "Hercules Kevin Sorbo." This lot exhibits discoloration and chipping paint.

**Estimate: \$3,000 - 6,000**



**897**  
Pair of Hand-Drawn Rod Lord Production Cels  
**The Hitchhiker's Guide To The Galaxy (1981-1981)**

A pair of hand-drawn Rod Lord production cels from the sci-fi comedy series The Hitchhiker's Guide to the Galaxy. Throughout the show, segments that covered information from the Hitchhiker's Guide book were animated. This set consists of two Rod Lord hand-drawn transparent production cels of a Vogon and Ford Prefect (David Dixon). These production cels come with one film negative attached to each. This collection exhibits adhesive residue and mild discoloration on the film negative. Dimensions (each): 13" x 11.25" (33.25 cm x 28.75 cm) Sold without copyright; see notice in the Buyer's Guide.

**Estimate: \$1,500 - 3,000**

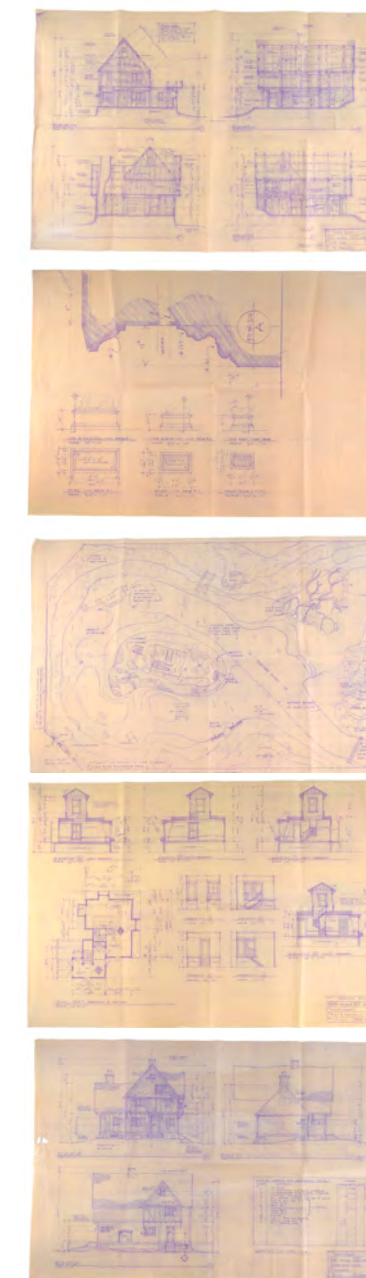

**898**  
Set of Five Blueprints with Cast and Crew Gifts  
**Hocus Pocus (1993)**

A set of five blueprints with cast and crew gifts from Kenny Ortega's fantasy-comedy Hocus Pocus. The witchy Sanderson sisters (Bette Midler, Sarah Jessica Parker, and Kathy Najimy) were resurrected on All Hallows' Eve.

This lot originated with a crew member. It consists of five blueprint copies labeled for key set pieces; a cotton black and purple crew jacket featuring three witches embroidered in black on the back and the film title embroidered in matching colors; two purple film booklets; and a polaroid of the Sanderson sisters and the bus driver inside the bus. This lot exhibits folding, rips, and stains from production and handling. Dimensions: 35.75" x 24" (90 cm x 61 cm)

**Estimate: \$1,200 - 2,400**



**899**  
Iris' (Kate Winslet) Bathing Suit  
**The Holiday (2006)**

Iris' (Kate Winslet) bathing suit from Nancy Meyers' romantic comedy *The Holiday*. Iris wore her bathing suit when she gave Arthur Abbott (Eli Wallach) swimming lessons. Customized for production, this black Lycra Calvin Klein one-piece bathing suit features wide straps and a padded, pleated chest inset with underwire. It exhibits crinkling, light staining, and fraying along the bottom from production wear.

**Estimate: \$400 - 800**



**900**  
"Wet Bandits" Chicago  
Sun-Times Newspaper Cover  
**Home Alone 2: Lost In  
New York (1992)**

A Chicago Sun-Times newspaper cover headlined "Wet Bandits" from Chris Columbus' Christmas comedy sequel *Home Alone 2: Lost in New York*. A newspaper blew onto the McCallister porch the night before Kevin's (Macaulay Culkin) trip to New York. This production-made, color-printed cover headlined "Wet Bandits' escape during prison riot" and featuring Harry (Joe Pesci) and Marv's (Daniel Stern) mugshots originated with Sun-Times marketing director Todd Galbate, who organized its printing by the Sun-Times' real presses for authenticity. Also included is a Letter of Authenticity from Galbate. The cover exhibits a vertical fold line, ink stains, and spine discoloration from production and age. Dimensions: 12" x 14.75" (30.5 cm x 37.5 cm)

**Estimate: \$2,000 - 4,000**



**901**  
Lost Boy's Screen-Matched Helmet  
**Hook (1991)**

A Lost Boy's screen-matched helmet from Steven Spielberg's comedy-adventure film *Hook*. The painted detailing and added accessories screen-match this helmet worn by a Lost Boy as he fought alongside Peter Pan against Captain Hook and the pirates. This lot consists of an orange fiberglass gourd-shaped helmet with red, black, white, yellow, and blue painted designs, features a gray resin animal's skull affixed to the front and decorated in faux green leaves and thin white nylon twine. The helmet includes a foam and cloth padding insert for the inside of the helmet. The padding exhibits crumbling and is fragile with handling.

**Estimate: \$2,000 - 4,000**



60" (152.5 cm)

**902**  
Cannon and Cannon  
Balls From Hook's Ship  
**Hook (1991)**

A cannon and cannon balls from Hook's ship from Steven Spielberg's comedy-adventure film *Hook*. Captain Hook kept a cannon and cannon balls aboard his ship throughout the film. This lot consists of five black-painted rubber foam balls; a black-painted fiberglass mold of nine balls; and a mobile brown-painted fiberglass cannon mounted on a wooden base featuring wooden wheels and brass metal embellishments throughout. This lot exhibits splitting wood on the cannon, a rough cracked edge around the ball mold, and flaking paint on the rubber. Dimensions: 60" x 31" x 30" (152.5 cm x 78.75 cm x 76.25 cm) Special shipping required; see notice in the Buyer's Guide.

**Estimate: \$1,500 - 3,000**



**903**  
Two Gold-Color  
Broken Alarm Clocks  
**Hook (1991)**

Two gold-color broken alarm clocks from Steven Spielberg's comedy-adventure film *Hook*. Captain Hook kept a collection of broken clocks in a museum to silence their ticking sounds. This lot consists of two gold-color metal alarm clocks with clear acrylic fronts, two gold-color metal handles, and two gold-color metal bell caps. One clock features a black metal hand and one clock features internal parts. This lot exhibits intentional damage from production. Dimensions: (each) 4.75" x 4.75" x 2.25" (12 cm x 12 cm x 5.75 cm) Contains mechanical components; see notice in the Buyer's Guide.

**Estimate: \$800 - 1,600**



**904**  
Bamboo Skateboard  
**Hook (1991)**

A bamboo skateboard from Steven Spielberg's comedy-adventure film *Hook*. Peter Banning rode a skateboard through the Lost Boys' hideout as he tried to escape them. This bamboo skateboard features red, blue, yellow, black, and white paint splatters, leather straps piecing the board together, brown wooden branches and metal rods on the underside for support, bamboo wheels, and leather and twine straps for support. This skateboard exhibits grime from age and chipped wood. Dimensions: 31" x 10" x 5" (78.75 cm x 25.5 cm x 12.75 cm)

**Estimate: \$800 - 1,600**



**905**  
 Reproduction Captain Hook  
 (Dustin Hoffman) Hook and Cuff  
**Hook (1991)**

Reproductions of Captain Hook's (Dustin Hoffman) hook and cuff from Steven Spielberg's fantasy-adventure film Hook. The notorious pirate captain had a large hook attached to his left arm to replace the hand he lost long ago. Created by the film's blacksmith, Tony Swatton, this metal hook is attached to a matching metal hand cover with a handle inside and decorative patterns engraved throughout the exterior, and a black leather lace-up cuff. The interior of the hand cover is engraved "Tony Swatton 2022" and is branded with the blacksmith's shop logo. The lot exhibits minor imperfections in the metal's grooves. Dimensions: 5" x 5" x 15" (12.75 cm x 12.75 cm x 38.25 cm)

**Estimate: \$3,000 - 6,000**

**906**  
 Cast-Autographed Pilot Script  
**Hot In Cleveland (2010-2015)**

A cast-autographed pilot script from Michael Lembeck's comedy series Hot In Cleveland. This script comes from the Season 1 episode pilot "Dead Is The New 90." This 55-page pilot script is bound in a pink cover as a shooting draft dated February 5, 2010. The script is autographed by Valerie Bertinelli, Wendie Malick, Jane Leeves, and Betty White in black marker. This lot exhibits a minor stain on the back cover. Dimensions: 8.5" x 11" x 0.25" (21.75 cm x 28 cm x 0.75 cm)

**Estimate: \$1,000 - 2,000**

**907**  
 Dr. Gregory House's (Hugh Laurie)  
 Commemorative Cane  
**House (2004-2012)**

Dr. Gregory House's (Hugh Laurie) commemorative cane from the production of David Shore's medical drama series House. Fox gifted a select number of the canes House used to walk throughout the series, taken from the recently deconstructed set, to executives in commemoration of the series finale. This brown wooden cane is finished with lacquer and features a black rubber ferrule. Also included is a Letter of Authenticity from Eric A. Candiani, former Fox Denver Vice President of Marketing and Creative Services and the cane's original recipient. It exhibits scratching along the body and scuffs to the ferrule from use. Dimensions: 36.5" x 5.25" x 1.5" (92.75 cm x 13.5 cm x 4 cm)

**Estimate: \$3,000 - 6,000**

**908**  
 Desiccated Corpse  
**House Of 1000  
 Corpses (2003)**

A desiccated corpse from Rob Zombie's black comedy film House of 1000 Corpses. Denise (Erin Daniels) walked down a corridor of desiccated corpses in Dr. Satan's (Walter Phelan) underground lair. This lot consists of one production-made desiccated skeleton. Composed of gray foam textured with fiber, it features articular hinge joints, adhered paper details to mimic mummified flesh, and polyester gray hair. This corpse exhibits extreme fragility with cracks in the foam, missing pieces, flaking paper, and Three missing fingers. Dimensions: 62" x 18" x 10" (157.5 cm x 45.75 cm x 25.5 cm)

**Estimate: \$600 - 1,200**



**909**  
 Vincent Sinclair's  
 (Brian Van Holt) Mask  
**House Of Wax (2005)**

Vincent Sinclair's (Brian Van Holt) mask from Jaime Collet-Serra's horror remake House of Wax. The young Vincent wore an assortment of wax face masks as he grew up. This plastic mask with differently sized eye holes, nostril holes, and a mouth slit is layered with latex "skin" painted to resemble human skin and finished with a life-like blush. It exhibits scuffing on the nose and small holes in the latex. Dimensions: 7" x 6" x 2" (18 cm x 15.25 cm x 5 cm)

**Estimate: \$2,000 - 4,000**

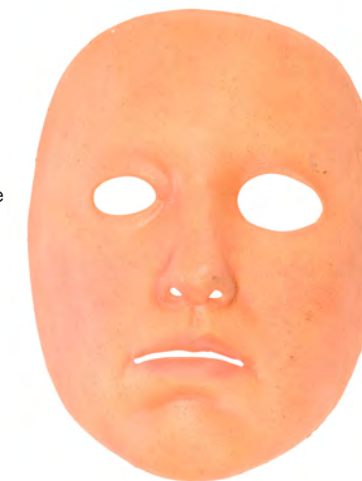

**910**  
 Grinch (Jim Carrey) Makeup Test Bust  
**How The Grinch Stole Christmas (2000)**

A Grinch (Jim Carrey) makeup test bust from Ron Howard's holiday comedy How the Grinch Stole Christmas. This pre-production bust was created by Rick Baker and his team during early tests to help design the prosthetics that turned Jim Carrey into the Grinch. Fixed to a biscuit foam bust, the foam latex appliances have been finished in green paint and feature an animal-like snout and wrinkles along the forehead and cheeks. The bust is mounted to a wooden base. This lot exhibits minor grime. Dimensions: 17.5" x 17.5" x 17" (44.5 cm x 44.5 cm x 43.25 cm)

**Estimate: \$1,000 - 2,000**

**911**  
 Del Spooner's (Will Smith) Pistol  
**I, Robot (2004)**

Del Spooner's (Will Smith) pistol from Alex Proyas' sci-fi action thriller I, Robot. Spooner used his sidearm throughout the film as he investigated the mysterious activity at US Robotics and the supposed robot murderer Sonny (Alan Tudyk). This lot consists of a static gun with an empty barrel shroud. The lower frame is made of resin, while the upper frame is machined metal, with plastic and hard rubber components to give it a detailed appearance. It features a circular accent on the rear by the hammer, all finished in black. This lot exhibits scratches and chipped paint. Dimensions: 8" x 6.5" x 2" (20.5 cm x 16.5 cm x 5 cm) Ownership may be restricted in some countries; see replica firearm notice in Buyer's Guide.

**Estimate: \$3,000 - 6,000**



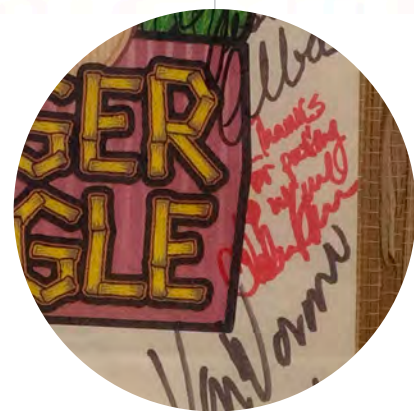

**912**  
Cast- and Crew-Autographed  
Bag Display  
**Idle Hands (1999)**

A cast- and crew-autographed bag display from Rodman Flender's horror-comedy Idle Hands. Burger Jungle was one of the locations for the serial killer's murders. This lot consists of a cast and crew autographed bag from Burger Jungle. The bag includes autographs from Jessica Alba, Dexter Holland, Katie Wright, Sean Whalen, Christopher Hart, Kelly Monaco, Fred Willard, and Seth Green, among others. It is mounted on bamboo behind a glass and bamboo wood frame with two bloodied and distressed ears partially inside the bag. This lot exhibits notable loss of adhesion on the bamboo frame. Dimensions: 15" x 23.5" x 2.75" (38.25 cm x 59.75 cm x 7 cm)

**Estimate: \$800 - 1,600**

**913**  
Hellenic Shield and Spear Pair  
**Immortals (2011)**

A Hellenic shield with spear pair from Tarsem Singh's fantasy action Immortals. This pewter-color painted plastic shield features engraved patterns with a center dome; and nylon straps with a leather-wrapped metal handle. The spears feature blue painted wood shafts; one has metal tips, the other has silver-color painted rubber tips. The shield exhibits a missing rivet, discoloration, scratches, and paint chipping; rubber tips exhibit curving and paint chipping; and the metal tips exhibit blunting and scratching. Dimensions: (spears) 84.5" x 2.5" x 1.5" (214.75 cm x 6.5 cm x 4 cm); (shield) 27" x 27" x 3" (68.75 cm x 68.75 cm x 7.75 cm)

**Estimate: \$600 - 1,200**



**914**  
Set of Robert Kurtzman-  
Autographed Production-Made  
Sutter Cane (Jurgen Prochnow)  
Novels  
**In The Mouth Of Madness (1994)**

Six Robert Kurtzman-autographed Sutter Cane (Jurgen Prochnow) novels from the production of John Carpenter's horror film In the Mouth of Madness. Trent (Sam Neill) discovered red lines on Cane's books that formed the outline of New Hampshire. This set of production-made paperback novels was previously exhibited at the Museum of Popular Culture (MoPOP) in Seattle. Each novel features an introduction page signed by Kurtzman in black marker with their first pages printed over every subsequent page. Also included is a Certificate of Authenticity from Kurtzman. The books exhibit mild edge and cover wear throughout. Dimensions: (each) 4.25" x 7" x 1" (11 cm x 18 cm x 2.5 cm)

**Estimate: \$3,500 - 7,000**

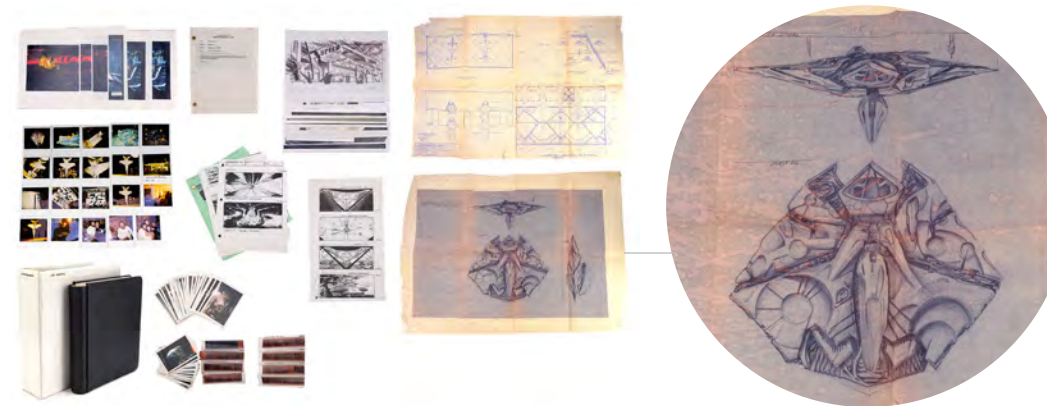

**915**  
Visual Effects  
Reference and Ephemera  
**Independence Day (1996)**

Visual effects reference and ephemera from Roland Emmerich's sci-fi action Independence Day. Originating from Joe Viskocil, this lot consists of one binder of 52 8.5" x 11" behind-the-scenes photos; 17 trading cards depicting SFX scenes from the film; two envelopes with 44 photos and accompanying film negatives; 20 behind-the-scenes Polaroid photos; one binder of approximately 400 storyboard copies with annotations, hand-written notes, and production memoranda; loose storyboard copy packets; and blueprints for attacker models. Pieces within the lot exhibit edgewear, tears, discoloration, staining, color fade, and corner dog-earring from use and age. Dimensions: 18" x 18" x 12" (45.75 cm x 45.75 cm x 30.5 cm)

**Estimate: \$1,200 - 2,400**

**916**  
Two Console-Bound  
Harvester Model Miniatures  
**Independence Day (1996)**

Two console-bound Harvester model miniatures from Roland Emmerich's sci-fi action film Independence Day. Captain Steven Hiller (Will Smith) and David Levinson (Jeff Goldblum) saw Harvester aliens at computer consoles when they flew into the Harvesters' Mothership. Constructed by effects company Cinema Production Services, these two ornately detailed cast resin models are hand-painted blue and green and come mounted to command stations inset with electronic wiring for powering lights. They exhibit chipped paint, exposing the resin, and have had their wires cut following production, rendering them non-functional. Dimensions: (each) 3" x 3" x 3" (7.75 cm x 7.75 cm x 7.75 cm) Contains electronics; see notice in the Buyer's Guide.

**Estimate: \$800 - 1,600**

**917**  
Nazi Soldier's Jacket  
**Indiana Jones And The Raiders Of  
The Lost Ark (1981)**

A Nazi soldier's jacket from Steven Spielberg's adventure film Raiders of the Lost Ark. Nazi soldiers wore their uniform jackets throughout the film as they sought to obtain the legendary Ark of the Covenant under the command of Oberst Herman Dietrich (Wolf Kahler). This green cotton blend button-up jacket features a Bermans & Nathans wardrobe tag hand-labeled "4C" sewn into the collar, silver-color metal buttons, and four front pockets. The jacket exhibits pilling fabric throughout, with tears in the top left pocket, collar, and left sleeve, partly from the removal of various patches.

**Estimate: \$3,000 - 6,000**





**918**  
**Framed Hand-Painted Gary Shipman "It Looks Like I'm Your Partner" Artwork Indiana Jones And The Raiders Of The Lost Ark (1981)**

Framed hand-painted artwork by comic artist Gary Shipman based on Steven Spielberg's action-adventure Raiders of the Lost Ark. In 2014, Shipman was licensed by Lucasfilm to create art from various company properties, including the Indiana Jones franchise. This artwork depicting Indy and Marion Ravenwood is titled "It Looks Like I'm Your Partner" in reference to Ravenwood's line, "I'm your goddamn partner!" It is rendered in mixed media on paper, signed by Shipman, and mounted behind glass in a brown wooden frame. The frame exhibits minor smudging. Dimensions: 26" x 20.5" x 1" (66 cm x 52.5 cm x 2.5 cm) Sold without copyright; see notice in the Buyer's Guide.

**Estimate: \$1,000 - 2,000**

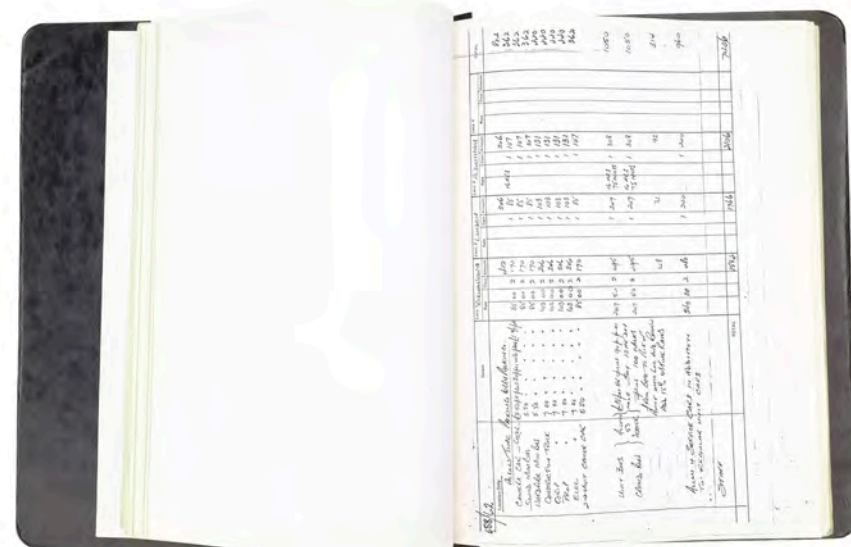

**919**  
**Production Budget Book Δ Indiana Jones And The Raiders Of The Lost Ark (1981)**

A production budget book from Steven Spielberg's action-adventure film Indiana Jones and the Raiders of the Lost Ark. Production budgets were used to track the expenses for filming in the United States and the United Kingdom. This 152-page production budget is dated "December 1, 1979" with revisions made "June 19, 1980." The budget book is bound in a black cover labeled "Raiders of the Lost Ark Budget and Key Code" with a red star sticker and printed annotations throughout. This lot exhibits a tear to the front cover and wear from handling and age. Dimensions: 9" x 11.5" x 1" (23 cm x 29.25 cm x 2.75 cm)

**Estimate: \$500 - 1,000**

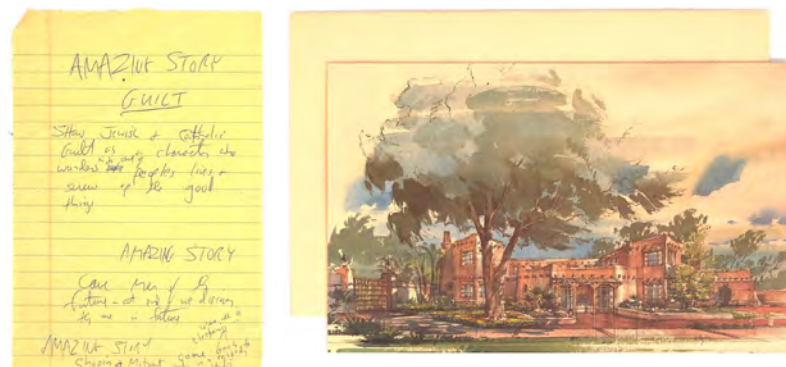

**920**  
**Steven Spielberg's Business Card with Stationery and Handwritten Amazing Stories Ideas Page Steven Spielberg**

Steven Spielberg's Amblin Entertainment business card with company stationery and a page of handwritten ideas for Amblin's anthology series Amazing Stories. This set consists of a cream-color card with the company's E.T. logo printed above the director's name and Universal City office address; a blank cream-color card with a printed illustration of Amblin's offices; an accompanying envelope with the office address printed on its back flap; and a sheet of unsigned lined yellow note paper with three story ideas for Amazing Stories episodes handwritten in blue pen. The set exhibits edge wear and bent corners. Dimensions: (largest) 8" x 11" (20.5 cm x 28 cm)

**Estimate: \$800 - 1,600**



**921**  
**Peruvian Temple Arrow Indiana Jones And The Raiders Of The Lost Ark (1981)**

A Peruvian temple arrow from Steven Spielberg's action-adventure film Raiders of the Lost Ark. Indiana Jones (Harrison Ford) set off many traps in his rush to escape the crumbling temple after obtaining the idol, including arrows fired out of the walls. This copper-color arrow features a dense rubber arrowhead for safety and a hollow plastic shaft allowing it to be fired out of an air cannon on set. It exhibits paint flaking and discoloration from production use and age. Dimensions: 9.5" x 1.25" x 0.75" (24 cm x 3 cm x 2 cm)

**Estimate: \$3,000 - 6,000**

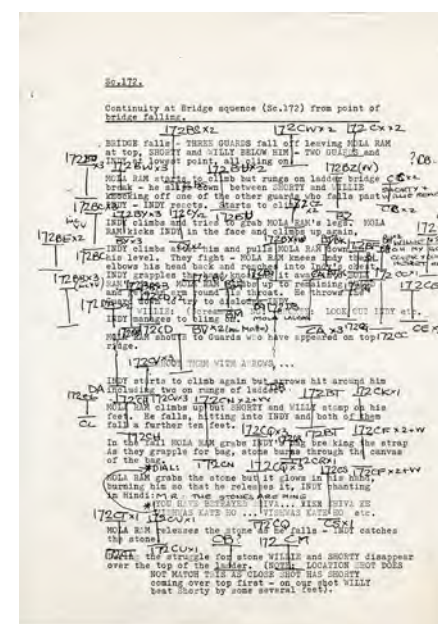

**922**  
**Continuity Photo and Notes Indiana Jones And The Temple Of Doom (1984)**

A continuity photo and notes from the production of Steven Spielberg's action-adventure prequel Indiana Jones and the Temple of Doom. This set originated with script supervisor Pamela Mann, who used the materials to track the appearance and placement of various costumes, props, and set dressing. This lot consists of one color photograph of Lao Che (Roy Chiao) and his men; one printed "Bridge sequence [sic]" continuity page with numbers written throughout; and an A5 size notebook of handwritten continuity notes. The photo exhibits staining around the edges, the paper exhibits corner creasing, and the notebook's cover exhibits scuffing. Dimensions: (largest) 8.5" x 11" (21.75 cm x 28 cm)

**Estimate: \$600 - 1,200**



**923**  
**Lorne Peterson Collection: Tank Side Door Model Miniature Indiana Jones And The Last Crusade (1989)**

A tank side door model miniature from Steven Spielberg's action-adventure sequel Indiana Jones and the Last Crusade. Indiana Jones (Harrison Ford) rescued his father, Henry (Sean Connery), and Marcus Brody (Denholm Elliott) from a tank before it crashed down a cliffside. Built for shots of the tank going over the cliff, this metal tank side door miniature comes from the collection of Industrial Light & Magic (ILM) model maker Lorne Peterson. It features a vinyl sticker of the Imperial standard of a fictionalized Hatay on the front and parts of a hinge on the left side. This lot exhibits rusting and lifted adhesive. Dimensions: 7.25" x 9.5" x 0.25" (18 cm x 24 cm x 0.5 cm)

**Estimate: \$1,500 - 3,000**

**924**  
 Bernie Pollack Collection:  
 Crew Satchel, Handbag, and Pouch  
**Indiana Jones And The Kingdom Of  
 The Crystal Skull (2008)**



A satchel, handbag, and pouch gifted by production to the crew of Steven Spielberg's action-adventure sequel Indiana Jones and the Kingdom of the Crystal Skull. The satchel is modeled after Indiana Jones' (Harrison Ford) signature bag.

This lot consists of a brown leather satchel created by Tony Nowak, who also created Indy's signature leather jacket for the film; a brown suede zip-up handbag emblazoned "Genre Productions"; a cream-color canvas pouch emblazoned "Indy IV"; and a printed note from Spielberg reading "Thanks for all your hard work!" The satchel is engraved "Indiana Jones Crew" and tagged for Ford's costume designer, Bernie Pollack. It exhibits white stains, and its tag is crumpled. Dimensions: (largest) 20" x 15" x 2" (51 cm x 38.25 cm x 5 cm)

**Estimate: \$1,500 - 3,000**

**925**  
 Young Murphy Cooper's (Mackenzie Foy)  
 Damaged Apollo Lunar Module Model  
**Interstellar (2014)**



Young Murphy Cooper's (Mackenzie Foy) damaged Apollo lunar module model from Christopher Nolan's sci-fi drama Interstellar. Murph asked her father Joseph (Matthew McConaughey) to fix her model after it mysteriously fell, only learning later that Joseph was the "ghost" responsible. This two-piece cast resin Apollo module model is hand-painted black, silver-, gold-, and copper-color and applied with "United States" and American flag decals. It is intentionally distressed by production to appear damaged with missing feet and cracks to its antennae, thrusters, and landing strut. It exhibits adhesive residue and paint chipping from age. Dimensions: 7" x 6" x 5" (17.75 cm x 15.25 cm x 12.75 cm)

**Estimate: \$1,200 - 2,400**

**926**  
 Set of Six Le Cercle Casino Plaques  
**James Bond: Dr. No (1962)**



Six Le Cercle casino plaques from Terence Young's Bond film Dr. No. MI6 agent 007 (Sean Connery) first uttered his name - "Bond, James Bond" - as he played baccarat chemin-de-fer against Sylvia Trench (Eunice Gayson) at Ken Adams' set based on the Le Cercle casino inside London's Les Ambassadeurs club. Le Cercle casino loaned £35,000 of its house plaques to EON Productions for the film under the supervision of two security guards. This lot consists of four £10, one £50, and one £100 plaques manufactured of glossy plastic composites engraved "Le Cercle" with serial numbers hot-stamped by the casino. £10 plaques of this style were later used in Richard Lester's A Hard Day's Night. Also included are b'bc 007 Autographs and Props Certificates of Authenticity for each plaque. The set exhibits some bubbling, bending, and discoloration along the edges. Dimensions: (largest) 4.5" x 3" x 0.5" (11.5 cm x 7.75 cm x 1.5 cm)

**Estimate: \$4,000 - 8,000**



**927**  
 Transition Model Scaramanga Golden Gun Replica  
**James Bond: The Man With The Golden Gun (1974)**

A transition model Scaramanga golden gun replica from Guy Hamilton's action-adventure film The Man with the Golden Gun. Francisco Scaramanga (Christopher Lee) wielded his gun as he targeted James Bond (Roger Moore). This replica gun, created by Steve Dymzso, posed as a transition model between the first and second generation replica models he later created. This lot consists of a gold-color brass gun in a wood and glass case features the "007" logo in white vinyl; a gold-color brass bullet, brass pen end cap; white cloth handling gloves; and two gold-color brass keys, one with a black tassel, to open the case. Included are a flier from SD Studios and a photo image of the replica gun, both signed by Steve Dymzso. This lot exhibits minor grime from handling. Dimensions: 14" x 9" x 4" (35.75 cm x 23 cm x 10.25 cm) Ownership may be restricted in some countries; see replica firearm notice in Buyer's Guide.

**Estimate: \$4,000 - 8,000**



**928**  
 Two Seats from James Bond's  
 (Roger Moore) Weaponized Speedboat  
**Moonraker (1979)**

Two seats from James Bond's (Roger Moore) weaponized speedboat from the James Bond spy-fi sequel Moonraker. Q (Desmond Llewelyn) provided this specialized craft during Bond's sojourn through the Amazon River, where he engaged in a fierce river battle against Jaws (Richard Keel). Used inside the converted Glastron CV23HT speedboat, these gray vinyl seats are backed by unpainted plywood. An attached metal hinge along the back edge exhibits rust and wear, and the seats exhibit discoloration, scratching, minor rips, and water staining. Dimensions: 30.5" x 76" x 4" (77.5 cm x 193 cm x 10.25 cm)

**Estimate: \$1,000 - 2,000**



**929**  
 Faberge Egg Replica  
**Octopussy (1983)**

A replica of a Faberge egg from John Glen's James Bond film Octopussy. MI6 sent James Bond (Roger Moore) to the London auction to ascertain the seller of the genuine Faberge egg after a counterfeit egg was discovered in East Berlin. This metal replica based on the production-made eggs features a gold-color lattice-work with faux gemstones inlaid in the design, and a surprise gold-color model miniature carriage inside, also decorated with inlaid faux gemstones. This lot exhibits very mild chipping of the gold-color finish and a loose hinge. Dimensions: 5.5" x 5.5" x 7.5" (14 cm x 14 cm x 19 cm)

**Estimate: \$4,000 - 8,000**



**930**  
 Pair of Production-Made  
 James Bond (Roger Moore)  
 Sharper Image Credit Cards  
**James Bond: A View To A Kill (1985)**

A pair of production-made James Bond (Roger Moore) Sharper Image credit cards from John Glen's action-adventure film A View to a Kill. Bond used his credit card when he loosened the lock on a window sill. This lot consists of two black- and gold-color The Sharper Image credit card faces with "007" printed in black and the card number and expiration date embossed; and two black- and white-color credit card backings with Bond's signature printed in black. This lot exhibits minor scratches from production use. Dimensions: 3.5" x 2.25" x 0.25" (9 cm x 5.75 cm x 0.75 cm)

**Estimate: \$1,500 - 3,000**



**931**  
 James Bond's (Pierce Brosnan)  
 Monte Carlo Casino Playing Cards  
**James Bond: Goldeneye (1995)**

James Bond's (Pierce Brosnan) Monte Carlo Casino playing cards from Martin Campbell's Bond film GoldenEye. Bond defeated Xenia Onatopp (Famke Janssen) with a 6 of Clubs and a King and Queen of Hearts during their game of baccarat at the Monte Carlo Casino. This set of playing cards consists of a 6 of Clubs and a King and Queen of Hearts, as well as a Jack of Spades and 5 of Diamonds. Each is printed on glossy white cardstock with light blue backs. The set exhibits minor edge wear throughout from production use. Dimensions (each): 3" x 4" (7.75 cm x 10.25 cm)

**Estimate: \$2,000 - 4,000**

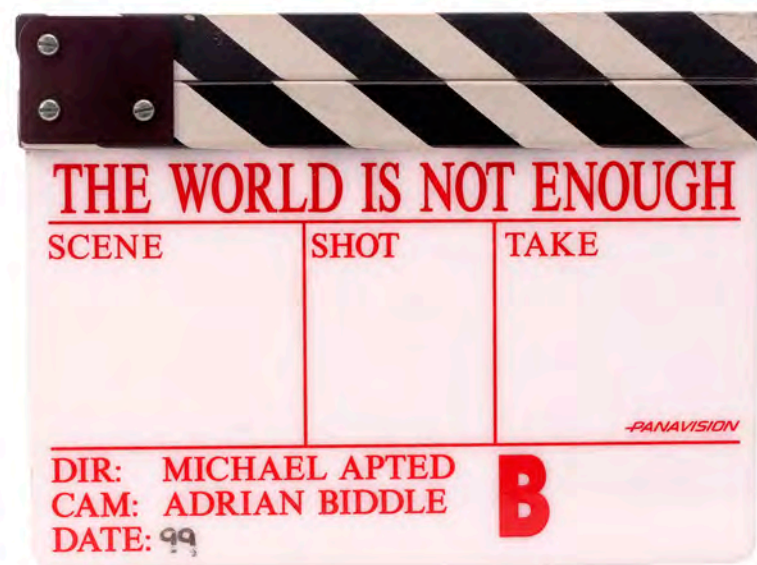

**932**  
 "B" Clapperboard  
**The World Is Not Enough (1999)**

A "B" clapperboard from the production of Michael Apted's Bond film The World is Not Enough. This clapperboard features an acrylic white slate with a magnetized black-and-white striped wooden clapper. It is engraved in red with the film's title, the names of director Michael Apted and cameraperson Adrian Biddle, and fields titled "Scene," "Shot," "Take," and "Date." The date features a hand-marked "99" in black marker. This clapperboard exhibits scratches in the acrylic, black scuffing, and chipped paint. Dimensions: 11" x 1" x 9.5" (28 cm x 2.75 cm x 24.25 cm)

**Estimate: \$2,000 - 4,000**



**933**  
 Set of Three Ocean Club Chips  
**James Bond: Casino Royale (2006)**

Three Ocean Club chips from Martin Campbell's Bond film Casino Royale. Stacks of chips appeared in the poker game that James Bond (Daniel Craig) joined at the Bahamas' One & Only Ocean Club. Custom-made for the production, each of these two-toned pink, green, and blue plastic poker chips in increments of \$5, \$25, and \$500, respectively, features the Ocean Club Bahamas "One & Only" logo printed in gold. Each chip exhibits scratching and scuffing from production use. Dimensions (each): 1.5" x 1.5" x 0.25" (4 cm x 4 cm x 0.75 cm)

**Estimate: \$2,000 - 4,000**



**934**  
 Kincade's (Albert Finney) Knife  
**Skyfall (2012)**

Kincade's (Albert Finney) knife from Sam Mendes' Bond film Skyfall. James Bond (Daniel Craig) threw Kincade's knife into Raoul Silva's (Javier Bardem) back to stop him from killing M (Judi Dench). This steel knife, one of two hero-style Kincade knives made for the film, features a hooked bolster with a matching butt and a curved grip painted black. The blade exhibits minor tarnishing from production use. Dimensions: 10" x 1.75" x 0.75" (25.5 cm x 4.5 cm x 2 cm) Blade was dulled by production.

**Estimate: \$2,000 - 4,000**



**935**  
 Set of Three Ape  
 City Building Model Miniatures  
**Jay And Silent Bob  
 Strike Back (2001)**

Three Ape City building model miniatures from Kevin Smith's satirical comedy Jay and Silent Bob Strike Back. Ape buildings appeared in Jay's (Jason Mews) vision of a Planet of the Apes-inspired future in which he and Silent Bob (Smith) were replaced by apes. Created by Matte World Digital, these resin and foam miniatures are hand-painted brown and yellow and textured to resemble stone. The set exhibits cracking and chipping from use, age, and conveyance. Dimensions: (largest) 12" x 26" x 20" (30.5 cm x 66 cm x 51 cm)

**Estimate: \$800 - 1,600**





**936**  
Jonathan Breck-Autographed Creeper Costume  
**Jeepers Creepers 2 (2003)**

A Jonathan Breck-autographed Creeper costume from Victor Salva's horror films Jeepers Creepers and Jeepers Creepers 2. The Creeper (Jonathan Breck) wore his hat, shirt, and trousers throughout both films and later wore his signature coat in Jeepers Creepers 2. This costume consists of a brown felt hat; a black synthetic wool coat with an attached capelet; a brown cotton shirt with snap closures; and dark brown cotton trousers. The interior of the coat features an autograph by Jonathan Breck dated for "1-8-05" and has been faintly hand-marked with "Creeper Hero." Also included is a letter of authenticity from Paul Davis, Chief Editor of Celluloid Shockers and three certificates of authenticity from Brian Penikas, creature and make-up effects artist. Production intentionally distressed this costume, which exhibits fragile seams.

**Estimate: \$3,000 - 6,000**



**937**  
Framed Production-Made TurboMan Cereal and Action Figure Boxes  
**Jingle All The Way (1996)**

Framed production-made TurboMan cereal and action figure boxes from the production of Brian Levant's classic Christmas comedy Jingle All The Way. Howard Langston (Arnold Schwarzenegger) could not find a TurboMan figure for Christmas, though his son Jamie (Jake Lloyd) loved TurboMan breakfast cereal. Created by Earl Hays Press for the production, this lot consists of a color-printed, flattened cardboard "TurboMan Cereal" box and a matching hollow cardboard and plastic TurboMan action figure box. The cereal box comes encased in a blue plastic frame which exhibits paint chips and scuffs, while the figure box exhibits fold lines from production. Dimensions: (largest) 15" x 24.25" x 0.5" (38 cm x 61.75 cm x 1.25 cm)

**Estimate: \$600 - 1,200**



**938**  
James Woods-Autographed Screen-Matched Jack Crow Leather Jacket  
**John Carpenter's Vampires (1998)**

A James Woods-autographed screen-matched Jack Crow leather jacket from John Carpenter's neo-Western horror film Vampires. Jack Crow (James Woods) wore his leather jacket throughout the film. Blood and distressing on the upper left shoulder of this screen-match to when Tony Montoya (Daniel Baldwin) confronted Crow over being bitten by his vampire girlfriend Katrina (Sheryl Lee). Obtained from an L.A. charity auction following production, this satin-lined leather jacket features a front zip closure and zip pockets with James Woods' signature in silver-color marker. It exhibits leather stiffness, discoloration, and mildew residue.

**Estimate: \$3,000 - 6,000**



**939**  
Zodanga Warrior Costume  
**John Carter (2012)**

A Zodanga warrior costume from Andrew Stanton's sci-fi-adventure film John Carter. Zodanga warriors wore their costumes as they chased Princess Dejah Thoris (Lynn Collins). This lot consists of red poly-cotton trunks marked "W 14"; a red poly-cotton neck wrap and arm wraps; a dark red leather skirt marked "MZ 107"; red- and black-painted rubber shin guards marked "MZ MR 121"; a bronze-color painted urethane and red leather vambrace labeled "132"; a bronze-color elbow cover and urethane shoulder covering and marked "MR ZS 9"; black leather boots with brown-painted rubber covers marked "45 MZ S 34"; brown leather, metal, and urethane body armor with a red poly-cotton cape and shoulder covering marked "MR" and "MB B MZ S-35"; and a red leather and rubber armor skirt marked "Ray Nicholas." The shoulder cover and rubber exhibit cracking.

**Estimate: \$2,500 - 5,000**



**940**  
Jojo Rabbit's (Roman Griffin Davis) Screen-Matched Wehrmacht Jacket  
**Jojo Rabbit (2019)**

Jojo Rabbit's (Roman Griffin Davis) screen-matched Wehrmacht jacket from Taika Waititi's comedy drama Jojo Rabbit. Jojo wore his jacket during the Allies' siege on Falkenheim before Captain Klenzendorf (Sam Rockwell) ripped it off him. Made of "bottle green" wool, this jacket features two front flap pockets, two button-down breast pockets, enlisted field service gorget patches, and an embroidered breast eagle. Screen-matched details include the two-tipped tear on the collar, the distress pattern around the right breast pocket, and the pulled thread on the left gorget patch. The jacket interior features a label for "Hero Collection." Production purposefully distressed this jacket to make it appear battle-worn. It exhibits loose threads and a raw edge on the sleeve hems.

**Estimate: \$3,000 - 6,000**

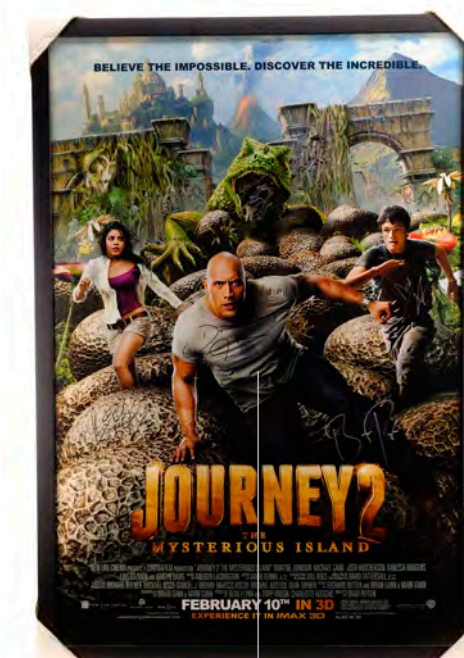

**941**  
Framed Cast- and Crew-Autographed One-Sheet Poster  
**Journey 2: The Mysterious Island (2012)**

A framed cast- and crew-autographed one-sheet poster from Brad Peyton's fantasy adventure Journey 2: The Mysterious Island. Hoping to find his grandfather, Sean Anderson (Josh Hutcherson) followed a signal to a mysterious island, accompanied by his step-father, Hank Parsons (Dwayne Johnson). This black wood-framed one-sheet features the autographs of director Brad Peyton and cast members Dwayne Johnson, Josh Hutcherson, Vanessa Hudgens, and Luis Guzman in black and silver-color ink. Included is a Warner Bros' signed letter of authenticity on the company's stationery. The lot exhibits minor scratching from storage. Dimensions: 29" x 42" x 1" (73.75 cm x 106.75 cm x 2.5 cm)

**Estimate: \$500 - 1,000**



**942**  
Full Battle-Damaged Blackstar Stunt Suit with Extra Hands  
**Jupiter's Legacy (2021)**

A complete battle-damaged Blackstar stunt suit from Steven S. DeKnight's television adaptation of Mark Millar's Jupiter's Legacy. The lot features full armor components, including two extra pairs of hands. The helmet, spaulders, full torso, arm, leg, and foot armor are rubberized foam painted silver-color, gray, bronze-color, rust, and green-gray atop a hammered texture to resemble metal. Three nylon, silicone, and rubber hand pairs (one set includes plastic hand inside) emulate fingerless gloves with knuckle- and backhand-mounted armor plates. The lot exhibits paint cracking, pitting, melting marks, paint chipping, scuffing, and scratching from use. Measures: 90" x 40" x 12" (228.75 cm x 101.75 cm x 30.5 cm) Special shipping required; see notice in the Buyer's Guide.

**Estimate: \$1,500 - 3,000**



**943**  
Blackstar's Clone Autopsy Body  
**Jupiter's Legacy (2021)**

Blackstar's clone autopsy body from Episode 5, "What's the Use?" of Steven S. DeKnight's television adaptation of Mark Millar's Jupiter's Legacy. The yellow-cast silicone body is painted in shades of purple, red, and blue. Its face emulates impact damage with stage-blood spattered viscera. A resin centerpiece with multicolor painted clips feature a light orange cast inset acrylic embedded in the chest. A "T"-shape abdomen cut displays stage blood and is hand-sewn closed. The back features four plug holes and remains mostly unpainted. The lot exhibits cracking, paint scuffing, sweating, and loose resin components. Dimensions: 72" x 18" x 12" (183 cm x 45.75 cm x 30.5 cm)

**Estimate: \$1,000 - 2,000**

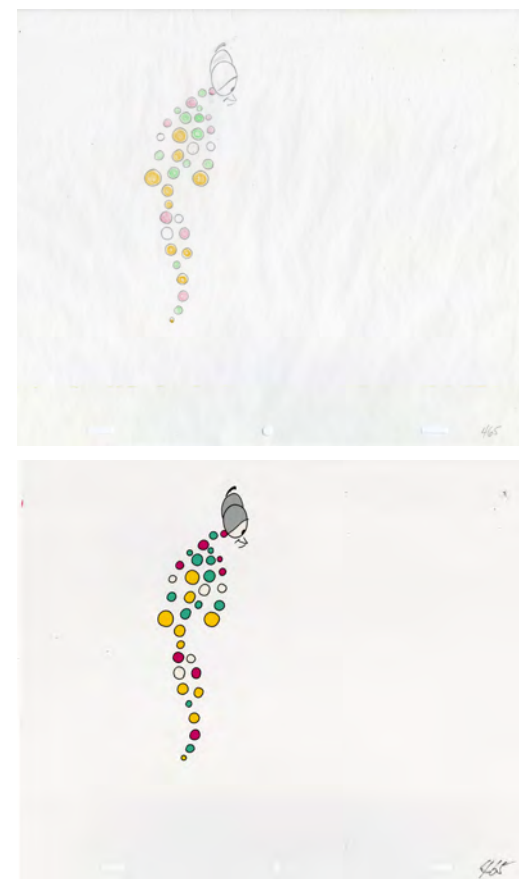

**944**  
Mr. DNA Hand-Painted Animation Cel and Hand-Drawn Layout Drawing  
**Jurassic Park (1993)**

A Mr. DNA hand-painted animation cel and hand-drawn layout drawing from the production of Steven Spielberg's sci-fi adventure Jurassic Park. Mr. DNA was created for the educational film that Mr. John Hammond (Richard Attenborough) presented to Dr. Alan Grant (Sam Neill) and his team. This lot consists of an acetate cel hand-painted with the profile image of Mr. DNA in white, gray, teal, yellow, and magenta colors and a hand-drawn layout drawing of the same image in graphite and colors. The cel and drawing are hand marked with "465." This lot exhibits minor wrinkling to the drawing. Dimensions: (each) 12.5" x 10.5" (31.75 cm x 26.75 cm) Sold without copyright; see notice in the Buyer's Guide.

**Estimate: \$2,500 - 5,000**



**945**  
Pair of Two Production Storyboard Binders and Production Paperwork  
**Jurassic Park (1993)**

Two production storyboard binders and production paperwork from Steven Spielberg's sci-fi-adventure film Jurassic Park. Production created copies of storyboards and documents to use during filming. This lot consists of 70 pages of a staff and crew list; partial scripts with handwritten annotations from Dan Ondrejko and J.M. Kenny; a 30-page booklet of Kauai Location Scout Information; a 53-page booklet of Kauai Information for shooting dates during August to September of 1992; one 438-page storyboard binder; and one 316-page storyboard binder. This lot exhibits minor grime and discoloration. Dimensions: 11.5" x 11.5" x 3.5" (29.25 cm x 29.25 cm x 9 cm)

**Estimate: \$2,500 - 5,000**



**947**  
Velociraptor Footprint Makers  
**Jurassic Park (1993)**

Velociraptor footprint makers from the production of Steven Spielberg's Academy Award®-winning sci-fi action-adventure Jurassic Park. Robert Muldoon (Bob Peck) used the distinctive footprints of the deadly velociraptors to track them after they escaped from their paddock. This lot consists of a pair of black nylon and rubber sandals with the toe area cut into dinosaur toe shapes, fastened to unpainted cast foam soles of velociraptor feet over hard resin interior structures. The foam exhibits some wear from use and age, including staining on the underside where it walked across the ground. Dimensions: (each) 10.5" x 7" x 4" (26.75 cm x 18 cm x 10.25 cm)

**Estimate: \$800 - 1,600**



**946**  
Set of Three Binders of Storyboards and Reference Images with Production Paperwork  
**The Lost World: Jurassic Park (1997)**

Three binders of storyboards, reference images, and production paperwork from Steven Spielberg's sci-fi adventure sequel The Lost World: Jurassic Park. Two binders contain 709 pages of printed storyboards; one contains 132 pages of reference images; one folder contains a 76-page shooting script, an 11-page contact list, 15-page crew list with 38 5" x 7" (13 cm x 18 cm) photos, 69 8.5" x 11" (21 cm x 30 cm) photos of location scouting; and 13 packets of 390 reference photos. This lot exhibits some residue, folder corners, and loose components. Dimensions: 11.5" x 12" x 11.5" (29.25 cm x 30.5 cm x 29.25 cm)

**Estimate: \$1,000 - 2,000**



**948**  
Hand-Drawn Jack Johnson Artwork and Concept Art Copies  
**Jurassic Park III (2001)**

Hand-drawn Jack Johnson artwork and concept art copies from Joe Johnston's sci-fi-adventure film Jurassic Park III. Johnson, illustrator for the film, created these drawings and concept art for various scenes. This lot consists of graphite and color hand-drawn perspective drawing signed by Johnson in black ink; four color concept art illustrations featuring Johnson's printed signature; and an enlarged copy of Johnson's perspective drawing spanning over three taped pages. This lot exhibits wrinkles, tears, and tape residue from production. Dimensions: 38.5" x 12" (98 cm x 30.5 cm) Sold without copyright; see notice in the Buyer's Guide.

**Estimate: \$1,000 - 2,000**



**949**  
Jeep Rearview Mirror Tag  
**Jurassic World (2015)**

A jeep rearview mirror tag from Colin Trevorrow's sci-fi-adventure film Jurassic World. Zach (Nick Robinson) and Gray (Ty Simpkins) fixed up an old Jeep to return to the theme park. This lot consists of a yellow and red card featuring the Jurassic Park logo and "029" in black. The card is laminated and has a brass-color No. 10 beaded ball chain with a connector. This lot exhibits production distressing and fold creases. Dimensions: 3.75" x 5.25" (9.75 cm x 13.5 cm)

**Estimate: \$2,000 - 4,000**



**950**  
Light-Up Mosasaurus Exhibit Light  
**Jurassic World (2015)**

A light-up Mosasaurus exhibit light from Colin Trevorrow's sci-fi action sequel Jurassic World. The Mosasaurus left from its illuminated lagoon on Isla Nublar to consume first a shark, and later, Indominus rex. This lot consists of a resin light box painted silver-color with a red plastic light screwed to the front and wiring extending from the base. The light illuminates when the wires are connected to a 9V battery. The box exhibits chipping resin and flaking paint in places from production use and age. Dimensions: 13" x 5" x 12" (33 cm x 12.75 cm x 30.5 cm) Contains electronics; see electronics notice in the Buyer's Guide.

**Estimate: \$600 - 1,200**



**951**  
The Motherfucker's (Christopher Mintz-Plasse) Stunt Pistols  
**Kick-Ass 2 (2013)**

The Motherfucker's (Christopher Mintz-Plasse) stunt pistols from Jeff Wadlow's superhero sequel Kick-Ass 2. The son of a deceased mafia boss, Chris D'Amico wielded a pair of custom pistols while in costume as the criminal mastermind The Motherfucker. This lot consists of a pair of static polyurethane stunt pistols designed after the 1911-style Para-Ordnance Nite-Tac handgun. The barrels are engraved with intricate designs while one gun is engraved with "MY WAY" and the other with "THE HIGHWAY." This lot exhibits discoloration, notable paint marks, and chipped paint. Dimensions: (each) 8.5" x 5.25" x 1.25" (22 cm cm x 13.5 cm x 3.5 cm) Ownership may be restricted in some countries; see replica firearm notice in Buyer's Guide.

**Estimate: \$3,000 - 6,000**



**952**  
Roy Munson's (Woody Harrelson) Amish Disguise Costume  
**Kingpin (1996)**

Roy Munson's (Woody Harrelson) Amish costume from Peter and Bobby Farrelly's sports comedy Kingpin. Munson wore his Amish disguise costume when he infiltrated the Amish community to convince Ishmael to enter the Reno bowling contest. The costume consists of black socks, a cream shirt (16-37 TALL) featuring "Roy Hand" handwritten inside the collar band, and black jeans accompanied by black webbing harness straps which fasten to metal buttons at the waistband. Also included is a small red heart-shaped "Las Vegas Rabies" vaccination tag that was found in one of the jean pockets. The shirt exhibits areas of brown staining on the front and around the cuffs.

**Estimate: \$800 - 1,600**



**953**  
Gary "Eggsy" Unwin's (Taron Edgerton) Kingsman Pistol  
**Kingsman: The Golden Circle (2017)**

Gary "Eggsy" Unwin's (Taron Edgerton) Kingsman pistol from Matthew Vaughn's spy sequel Kingsman: The Golden Circle. Eggsy, as with all Kingsman agents, carried the standard issue Kingsman pistol, which featured a secondary shotgun barrel for close-range use. This urethane pistol is cast off of a modified TT-30 with upper and lower barrels, painted black with a silver-color barrel detail and a brown grip. It exhibits scuffing to the finish from use. Dimensions: 8.75" x 5" x 1" (22.25 cm x 12.75 cm x 2.75 cm) Ownership may be restricted in some countries; see replica firearm notice in Buyer's Guide.

**Estimate: \$1,500 - 3,000**



**955**  
Preston Packard's (Samuel L. Jackson) Screen-Matched Helmet  
**Kong: Skull Island (2017)**

Preston Packard's (Samuel L. Jackson) screen-matched helmet from Jordan Vogt-Roberts' monster film Kong: Skull Island. Packard wore his helmet while flying to Kong Island. The details of this helmet's distressing match to shots of Packard wearing his helmet in the helicopter. This helmet consists of a fiberglass shell, two layers of foam, a pair of mesh-covered earphones, an adjustable mic, and a plastic eyeshield that can be raised or lowered by a knob on the top. The helmet comes in a nylon drab olive-green bag, and features a loose piece of hand-marked tape "P2." This helmet exhibits lifted adhesive, adhesive residue, some discoloration, and foam fragility. Contains electronics; see electronics notice in the Buyer's Guide.

**Estimate: \$1,500 - 3,000**



**954**  
Pair of Sculpted Hand Castings  
**King Kong (1976)**

A pair of sculpted hand castings from John Guillermin's adventure-horror film King Kong. These master sculpts were used to create the makeup effects for King Kong's hands. This lot consists of two hand sculpts made of brown-painted foam and mounted to plaster bases. These hands were sculpted to resemble the shape and texture commonly seen with gorilla hands. This lot exhibits cracking material along the fingers and discoloration on the base. Dimensions: 9.5" x 11" x 16.5" (24.25 cm x 28 cm x 42 cm)

**Estimate: \$800 - 1,600**



**956**  
Limited-Edition LAIKA Stop-Motion Puppet Faces Crew Gift  
**Kubo And The Two Strings (2016)**

Limited-edition stop-motion puppet faces from the production of Travis Knight's fantasy-adventure film Kubo and the Two Strings. Stop-motion animation studio LAIKA created 3D-printed resin Kubo (Art Parkinson), Monkey (Charlize Theron), and Beetle (Matthew McConaughey) puppet faces as gifts for crew members and press. These faces come backed with magnets inside a wooden box featuring the film's title and logos for LAIKA and distributor Focus Features. Also included is a LAIKA Certificate of Authenticity numbered "149/275" and a sheet of display instructions. The box exhibits minor scuffs from opening and handling. Dimensions: 12" x 6" x 4" (30.5 cm x 15.25 cm x 10.25 cm)

**Estimate: \$1,500 - 3,000**

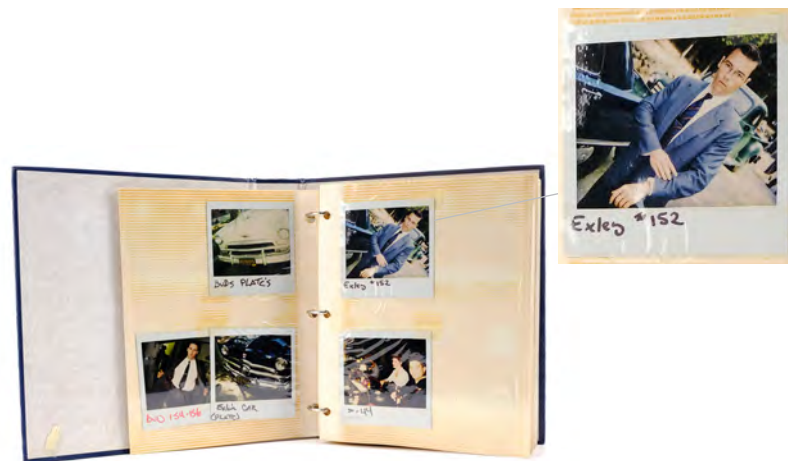

**957**  
Continuity Photo Binder  
**L.A. Confidential (1997)**

A continuity binder from Curtis Hanson's crime noir L.A. Confidential. Three policemen with different investigative tactics dove into a series of murders with links to corruption. This continuity binder features 65 plastic-sheeted pages of behind-the-scenes photography featuring various cast, including Russell Crowe and Guy Pearce, in costume and makeup; and set pieces and props. Many photos feature annotations with screen numbers and other production notes hand-marked in black and red ink. Included are 25 loose Polaroid photographs and 27 vellum color photograph copies hand-selected by the prop master as key reference from the production. They exhibit minor border staining and yellowing from age, while the binder features edge wear, creasing, and bent corners from use. Dimensions: 10.75" x 11.75" x 2.5" (27.5 cm x 30 cm x 6.5 cm)

**Estimate: \$800 - 1,600**



**959**  
Fire Nation  
Soldier Uniform  
**The Last  
Airbender (2010)**

A Fire Nation soldier uniform from M. Night Shyamalan's action-adventure film The Last Airbender. Fire Nation soldiers wore uniforms as they raided the Northern Water Tribe. This lot consists of a black robe (size 40) with red and goldenrod trim marked "#147 Kuno"; black trousers (size S) labeled "D. Manizot 3"; a black padded collar; a dark red sash; a black leather belt (size 32) with gold-color designs; a pair of black cords; embossed black leather boots (size 10); and a two-piece black urethane cuirass marked "1112" on the front piece and "1133" on the back. This lot exhibits deterioration on the boots.

**Estimate: \$800 - 1,600**



**958**  
Goblin Helmet  
**Labyrinth (1986)**

A goblin helmet from Jim Henson's fantasy adventure Labyrinth. Servants in the army of Goblin King Jareth (David Bowie) wore their armor as they attempted to prevent Sarah (Jennifer Connelly) from reclaiming her baby brother. This dark gray resin helmet features a pair of upward-facing horn accents on the sides and an asymmetrical cone-like detail protruding from the front. The ear sections feature a pair of beige leather decorative details. It exhibits some scuffing and rust-like marks deliberately added by production, as well as some glue residue on the interior. Dimensions: 17" x 13" x 12.5" (43 cm x 33 cm x 31.75 cm)

**Estimate: \$2,000 - 4,000**



**960**  
Kate Andrich's (Emilia  
Clarke) Elf Coat  
**Last Christmas (2019)**

Kate Andrich's (Emilia Clarke) elf coat from Paul Feig's romantic comedy Last Christmas. Andrich wore her elf coat while working as an "elf" at a London Christmas shop open year-round. This lot consists of a green velveteen coat with a hook-and-bar and snap front enclosure, cream-color faux fur trimming, a matching unattached faux fur collar with a black ribbon tie, and a white silken lining with a printed floral pattern. Also included is a paper production tag labeled "Best Neckline for Use Without Collar" and "1. Kate Elf Hero 1." The lining exhibits minimal thread pulling.

**Estimate: \$1,000 - 2,000**



**961**  
Miranda North's  
Flight Suit Δ  
**Life (2017)**

Miranda North's flight suit from Daniel Espinosa's sci-fi horror Life. North became embroiled in a hostile alien discovery aboard the International Space Station. This brown polyester, one-piece jumpsuit features a full-length double zipper, open and zip pockets, screw-on brass and copper painted metal "sensor" studs, and hook-and-loop strips on the legs. A navy blue namepatch in English and Cyrillic and flight wings, in yellow-gold embroidery are sewn to the left chest. An embroidered Union Jack flag patch is sewn to the left bicep. "NORTH," "HERO," "NO VELCRO," and a circled "1" are hand-marked in black on an interior white tag. The lot exhibits minor fraying of front pocket stitching and minor marks.

**Estimate: \$800 - 1,600**

**963**  
Pair of Light Wands Δ  
**Life (2017)**

Light wands from Daniel Espinosa's sci-fi horror Life. Dr. David Jordan and Miranda North used light wands to lure the hostile "Calvin" alien. The two wands feature off-white painted resin handles housing batteries (not included), orange paint pinstriping, a power indicator decal, a silver-color and black "MADE IN UK" embossed inlay, and a clear acrylic tube with interior strip LEDs. The gray polyester holster features sewn-on orange nylon straps with hook-and-loop adjustments. The wands exhibit discoloration and minor scratching. Dimensions: 13.5" x 9.5" x 1.5" (34.5 cm x 24.25 cm x 4 cm) Contains electronics; see electronics notice in the Buyer's Guide.

**Estimate: \$800 - 1,600**



**962**  
David Jordan's  
Flight Suit Δ  
**Life (2017)**

David Jordan's flight suit from Daniel Espinosa's sci-fi horror Life. Jordan became embroiled in a hostile alien discovery aboard the International Space Station. This brown polyester, one-piece jumpsuit features a full-length double zipper, pockets, painted metal "sensor" studs, and hook-and-loop strips on the legs. A navy-blue fabric namepatch in English and Cyrillic and flight wings in yellow-gold embroidery are sewn to the left breast. An embroidered Russian Space Agency assignment patch is sewn to the right chest. The left arm features an embroidered American flag, the right arm features two embroidered assignment patches, all sewn-on. The lot exhibits minor fraying around the neck and arm openings.

**Estimate: \$800 - 1,600**

**964**  
Nicky's (Adam Sandler)  
Hell Costume  
**Little Nicky (2000)**

Nicky's (Adam Sandler) Hell costume from Steven Brill's supernatural comedy Little Nicky. Nicky wore his costume while he was in Hell before he changed clothes on Earth. This costume consists of a black textured poly-blend robe with a red lining, decorative front button closures, and embroidered designs on the back; a black cotton T-shirt; black athletic shorts; white cotton tube socks with red bands; and four patches. The robe features an interior label printed with "Mr. Adam Sandler 2" and the shorts also feature an interior label printed with "Mr. Adam Sandler." The patches consist of one Pantera patch, two Iron Maiden patches, and one production-made patch. This costume exhibits snagged threads and edgewear on the decorative buttons.

**Estimate: \$1,500 - 3,000**





**965**  
Old Joe's (Bruce Willis)  
Bloodied Jacket Costume  
**Looper (2012)**

Old Joe's (Bruce Willis) bloodied jacket costume from Rian Johnson's sci-fi-action film *Looper*. Old Joe wore his costume when he used the dead body of one of Abe's (Jeff Daniels) men as a shield. This lot consists of a stage blood-stained brown leather jacket with a polyester lining; a white cotton shirt (size M); and dark blue cotton denim jeans (32 x 32). This lot exhibits a rip on the left back side and right front pocket and discoloration on the collar of the jacket.

**Estimate: \$4,000 - 8,000**



**966**  
Jacques Grande's  
(Justin Timberlake) Hockey Jersey  
**The Love Guru (2008)**

Jacques Grande's (Justin Timberlake) hockey jersey from Marco Schnabel's romantic comedy *The Love Guru*. "Le Coq" Grande wore a hockey jersey while keeping goal for the Los Angeles Kings. The long-sleeve polyester-nylon Spandex athletic-knit white jersey (size 56) features various sewn-on patches and indicia relating to the Los Angeles Kings in purple, black, and silver-color team colors. A NHL Stanley Cup 2008 patch is sewn above the right breast, a tri-color "1" patch sewn to each bicep, and a larger tri-color "1" sewn at the back, beneath the "GRANDE" sewn-on patch. The lot is hand-marked "JT" on the reverse of the neck tag. It exhibits discolorations across the front and lower sleeves.

**Estimate: \$800 - 1,600**



**967**  
MASH Helicopter Panel  
**M\*A\*S\*H (1972-1983)**

A MASH helicopter panel from the war comedy-drama series *M\*A\*S\*H*. The doctors and other medical staff working at the 4077th Mobile Army Surgical Hospital had patients airlifted to them in helicopters from the frontlines during the Korean War. This lot consists of a helicopter side panel, made of wood, painted olive green with white and black stenciled lettering reading "4077th Mobile Army Surgical Hospital" with a white caduceus. It exhibits signs of wear from use and age, including scuffing, chipping, cracking, adhesive residue, and holes drilled around the edges. Dimensions: 32.75" x 30.25" x 0.5" (83.25 cm x 77 cm x 1.5 cm)

**Estimate: \$1,500 - 3,000**



**968**  
Father Mulcahy's (William Christopher)  
Chaplain Vestments  
**M\*A\*S\*H (1972-1983)**

Father Mulcahy's (William Christopher) chaplain vestments from Larry Gelbart's comedy drama *MASH*. As the 4077th Mobile Army Surgical Hospital U.S. Army chaplain, Mulcahy wore chaplain vestments as he performed his duties. The white plastic tab collar black nylon apron fastens with ties. The ivory poly-cotton stole features an embroidered crucifix and crown; and off-white cotton socks feature a black embroidered crucifix. A metal ball-chain necklace with crucifix exhibits edgewear and scuffing. The ties exhibit discoloration; the stole exhibits heavy deterioration of the outer shell, separating embroidery, and a partially detached tassel corded end. The socks exhibit minor discoloration and fabric pilling, and the necklace exhibits edgewear and scuffing.

**Estimate: \$800 - 1,600**



**970**  
Framed "Sand Pirates of  
the Sahara" Poster  
**The Majestic (2001)**

A framed "Sand Pirates of the Sahara" poster from Frank Darabont's drama *The Majestic*. Blacklisted writer Peter Appleton (Jim Carrey) was shocked out of amnesia when *The Majestic* promoted his film "Sand Pirates of the Sahara." This color-printed poster depicting stars Brett Armstrong (Bruce Campbell) and Ramon Jamon (Cliff Curtis) features the headline "Raging Passions and Clashing Swords in the Pitiless Desert Wastes..." at top with the title, credits, and copyright date "1951" printed beneath. It comes mounted behind glass in a brown wooden frame. The frame exhibits a ding on its lower front edge. Dimensions: 42" x 29" x 1" (106.75 cm x 73.75 cm x 2.5 cm)

**Estimate:  
\$1,500 - 3,000**



**969**  
The Swamp's Ammo-Crate Lounge Chair  
**M\*A\*S\*H (1972-1983)**

The Swamp's ammo-crate lounge chair from the legendary comedy drama *MASH*. The 4077th Mobile Army Surgical Hospital's (MASH) Benjamin "Hawkeye" Pierce (Alan Alda) and compatriots retired to the tent known as The Swamp, which had a chair like this adorning its exterior. This wood chair features black paint stenciled markings of names, warnings, and serial numbers, and slats with blue painted blocks. It is constructed of wood slats of varying thickness nailed together to emulate salvage from multiple crates. It exhibits nicks, scratches, worn down edges, and rusted nail heads. Dimensions: 24" x 34" x 42" (61 cm x 86.5 cm x 106.75 cm) Special shipping required; see notice in the Buyer's Guide.

**Estimate: \$800 - 1,600**



**971**  
Framed Frank  
Darabont-Autographed  
One-Sheet  
**The Majestic (2001)**

A framed one-sheet autographed by Frank Darabont from the promotion of Darabont's drama *The Majestic*. Matte World Digital produced digital matte paintings and other VFX for the film. This original full-color one-sheet depicting amnesiac Peter Appleton (Jim Carrey), Adele Stanton (Laurie Holden), and the Majestic Theater was gifted by Darabont to Matte World after production. It is signed "To the geniuses at Matte World, with deepest thanks for making our world...love and awe" in black marker by Darabont and comes mounted behind glass in a brown wooden frame. The poster exhibits minor edge wear. Dimensions: 28" x 41" x 2" (71.25 cm x 104.25 cm x 5 cm)

**Estimate: \$500 - 1,000**

**972**  
**Majestic Ticket Display**  
**The Majestic (2001)**

A Majestic ticket display from Frank Darabont's drama The Majestic. After amnesiac Peter Appleton (Jim Carrey) helped restore The Majestic to its former glory, the citizens of Lawson bought tickets to such films as Appleton's own "Sand Pirates of the Sahara." This display consists of a production-made orange paper 25-cent ticket labeled "Majestic Theatre Lawson, California," numbered "174047," and mounted beneath two color-printed stills and a poster for the film behind glass in a bracketed black wooden frame. The back of the frame is applied with tape and exhibits scratching. Dimensions: 22.5" x 18" x 1 (57.25 cm x 45.75 cm x 2.5 cm)

**Estimate: \$800 - 1,600**



**973**  
**Hand-Painted Michael Pangrazio**  
**House on a Cliff Matte Painting**  
**Malice (1993)**

A hand-painted Michael Pangrazio house on a cliff matte painting from Harold Becker's neo-noir thriller Malice. After Andy (Bill Pullman) confronted Tracy (Nicole Kidman) about the scheme, back at their home, Jed (Alec Baldwin) told Tracy to give Andy what he wanted so they could leave the country. This lot consists of one oversize matte painting on a framed glass panel. It features a hand-painted image of a lone house on a seaside cliff during twilight hours with an unpainted ocean area. It also features a hand-marked "MZ" on the upper right corner, and hand-marked numbers on the painting's periphery. This lot exhibits chipped paint, scratches, and lifted tape. Dimensions: 49.5" x 61" x 1" (125.75 cm x 155 cm x 2.5 cm) Special shipping required; see notice in the Buyer's Guide. Sold without copyright; see copyright notice in the Buyer's Guide.

**Estimate: \$1,500 - 3,000**



**974**  
**Animatronic Buck the Dog**  
**Married... With Children (1987-1997)**

An animatronic Buck the Dog from the sitcom Married.. with Children. The Bundys' dog, Buck, was a part of the family throughout the series' run. This animatronic dog was crafted to appear identical to the live briard that often portrayed the character. It features faux multicolor fur, brown glass eyes, yellowed teeth, and a pink tongue. The battery-operated dog is mounted to a black wooden base and is designed to open its mouth and turn its head with an included controller. Also included is a photo of Buck. It exhibits signs of wear from use and age, including cracking to its nose, scuffing, paint chipping to the base, and difficulty turning its head to the right due to worn gears. Dimensions: 46" x 16" x 25" (117 cm x 40.75 cm x 63.5 cm) Contains electronics and mechanics; see electronics notice in the Buyer's Guide.

**Estimate: \$3,000 - 6,000**



**975**  
**Green Incinerated Skeleton**  
**Mars Attacks! (1996)**

A green incinerated skeleton from Tim Burton's sci-fi comedy Mars Attacks! Green skeletons littered the ground after Martians incinerated humans with their ray guns. This partial cast resin skeleton extending from skull to pelvis and missing its left arm and legs is hand-painted neon green with black and white teeth. It is textured by production to mimic bones and applied with grime to appear burned. Several screws used to secure the bones have come loose, and the resin exhibits chipping and small fractures throughout, most visibly in the face. Dimensions: 16" x 38" x 9" (40.75 cm x 96.5 cm x 23 cm)

**Estimate: \$1,500 - 3,000**

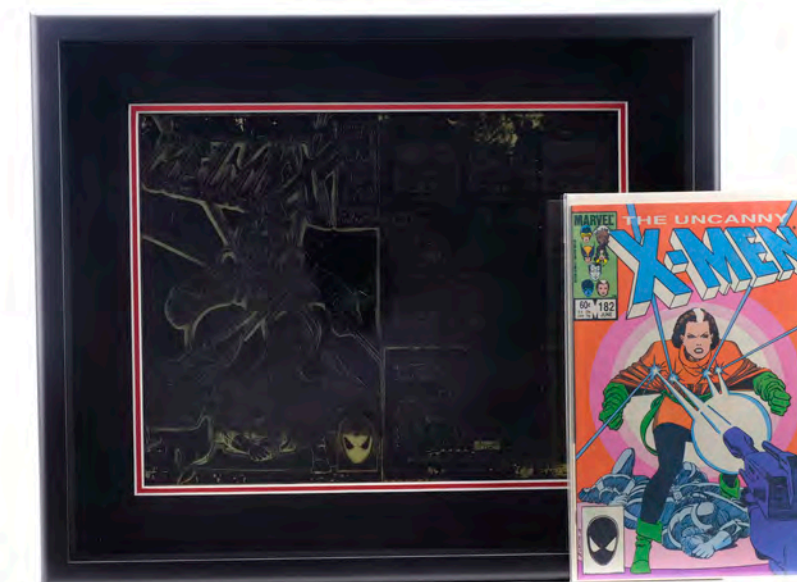
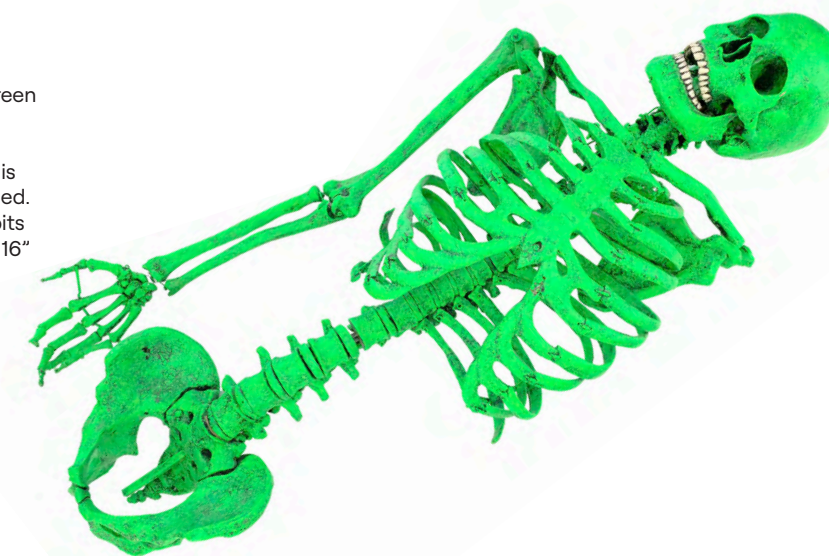

**976**  
**Framed Uncanny X-Men No. 182**  
**Cover Printing Plate with Comic Book**  
**Marvel Comics**

A framed printing plate for the cover of Uncanny X-Men issue 182 published by Marvel Comics in June 1984 with a copy of the issue. Known for having one of the highest print circulations of any comic book of the era, the issue was written by Chris Claremont with pencils and cover art by John Romita, Jr., inks by Dan Green, and colors by Glynis Wein. Created specifically for the direct sales version of the comic, this metal black plate featuring Rogue was originally curved from being stretched around a printing drum, but has since been matted behind plexiglass in a black wooden frame in order to flatten it. The comic book exhibits minor edge wear. Dimensions: (largest): 18.5" x 15.5" x 2.25" (47 cm x 39.5 cm x 5.75 cm)

**Estimate: \$2,000 - 4,000**

**977**  
**Giant-Size X-Men No. 1, Captain**  
**America No. 117, and Amazing Spider-**  
**Man No. 101 with 16 Silver and Bronze**  
**Age Comic Books [Qty. 19]**  
**Marvel Comics**

A Giant-Size X-Men no. 1, Captain America no. 117, Spider-Man no. 101, and 16 other Silver and Bronze Age-era Marvel superhero issues. See full description online.

**Estimate: \$1,000 - 2,000**





**978**  
Giant-Size X-Men No. 1 and Star Wars No. 1 with 17 First Bronze Age Comic Books [Qty. 19]  
**Marvel Comics**

A Giant-Size X-Men no. 1, Star Wars no. 1, and 17 other first Bronze Age-era Marvel superhero issues. See full description online.

**Estimate: \$1,000 - 2,000**



**981**  
Thor's (Chris Hemsworth) T-Shirt and Jeans  
**Thor (2011)**

Thor's (Chris Hemsworth) T-shirt and jeans from Kenneth Branagh's superhero film Thor. The Asgardian god of thunder wore his T-shirt and jeans in the diner when he overheard locals discussing a satellite crash while sitting with Jane (Natalie Portman), Darcy (Kat Dennings) and Erik (Stellan Skarsgård) and when he attempted to retrieve his hammer Mjolnir. The lot consists of a navy blue T-shirt and a pair of black Levi's® 501 straight-leg jeans (waist size 36 and length 34). A label attached to the care label within the T-shirt reads "Thor."

**Estimate: \$2,000 - 4,000**



**982**  
Set of Three Asgard Tours Posters  
**Thor: Love And Thunder (2022)**

A set of three Asgard Tours posters from Taika Waititi's action-adventure film Thor: Love and Thunder. Asgard Tours ran in New Asgard as a sightseeing attraction for tourists. This lot consists of three Asgard Tours posters: one displays the aerial sightseeing layout on each ship; one displays the ticket prices, including day passes and family packs, and the hours of operation; and one graphic illustration poster promotes the attraction. These posters are mounted in acrylic and metal frames. This lot exhibits minor scuffing to the frame and minor bends to the poster sheets. Dimensions: 24" x 34" x 0.5" (61 cm x 86.5 cm x 1.5 cm)

**Estimate: \$2,000 - 4,000**



**979**  
Dr. Arnim Zola's (Toby Jones) Camera  
**Captain America: The First Avenger (2011)**

Dr. Arnim Zola's (Toby Jones) camera from Joe Johnston's superhero film Captain America: The First Avenger. Dr. Zola calibrated his machines for the experiment to harness the Tesseract. This lot consists of one camera. Composed of a vented and tiered resin base painted silver-color with a viewfinder made of plastic and metal, this camera features decorative dials, cables, and glass transistor tubes. This lot exhibits some scuffing, chipping in the finish, and mild discoloration on the cables. Dimensions: 28" x 13" x 24" (71.25 cm x 33 cm x 61 cm)

**Estimate: \$1,500 - 3,000**



**980**  
Mordo's (Chiwetel Ejiofor) Sling Ring  
**Doctor Strange (2016)**

Mordo's (Chiwetel Ejiofor) sling ring from Scott Derrickson's action-fantasy film Doctor Strange. Mordo kept his sling ring attached to his robe and wore it as he trained Dr. Strange. This lot consists of a gold-color sculpted metal sling ring featuring carved foreign language and two ring slots. This lot exhibits grime throughout from use and minor tarnishing from age. Dimensions: 3.5" x 0.5" x 1.5" (9 cm x 1.5 cm x 4 cm)

**Estimate: \$2,000 - 4,000**

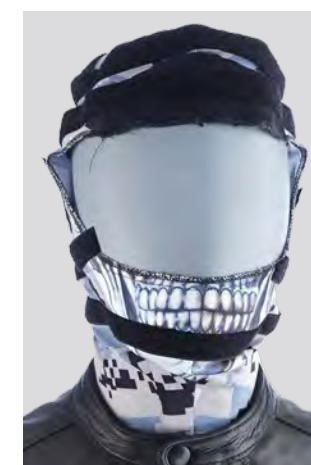

**983**  
Robbie Reyes' Screen-Matched Ghost Rider Jacket with SFX Hood and Costume Components  
**Marvel's Agents Of S.H.I.E.L.D. (2013-2020)**

Robbie Reyes' screen-matched Ghost Rider jacket with an SFX hood and additional costume components from Marvel's Agents of S.H.I.E.L.D. Patterns on the jacket screen-match to when Ghost Rider wore his signature costume when he emerged from an interdimensional portal in the Season 4 episode "The Return." This costume consists of a winter camo poly-blend zip-up pyro effects hood with fastening strips and a SFX bonnet; a black leather jacket with white accents; a burgundy cotton T-shirt; black leather gloves; a black neoprene rig belt; dark gray cotton jeans, and black-and-white cotton and rubber sneakers. The hood is hand-marked with "Stunt Robbie" in black ink. This costume exhibits scuffing on the jacket and shoes.

**Estimate: \$2,500 - 5,000**



**984**  
The Bus Model Miniature with Five S.H.I.E.L.D. Patches  
**Marvel's Agents Of S.H.I.E.L.D. (2013-2020)**

"The Bus" model miniature with five S.H.I.E.L.D. patches from Marvel's Agents of S.H.I.E.L.D. A model CXD 23215 Airborne Mobile Command Station, aka "The Bus," sat in Phil Coulson's office and S.H.I.E.L.D. headquarters in Seasons 1 through 3; and agents wore patches throughout the series. This cast resin and acrylic six-engine jet model is painted charcoal and chrome with a white S.H.I.E.L.D. logo. Included is a metal screw-on display stand with a matching logo, and five sewn-fabric multisized and multicolor embroidered logo patches. The cockpit was removed following production, the nose exhibits splitting, and a patch exhibits minor staining. Dimensions: (largest) 15" x 14" x 4" (38.25 cm x 35.75 cm x 10.25 cm)

**Estimate: \$1,500 - 3,000**



**985**  
**Tactical Vest, I.C.E.R. and A.T.C.U. Pistols, and Machine Gun**  
**Marvel's Agents Of S.H.I.E.L.D. (2013-2020)**

A tactical vest, I.C.E.R. and A.T.C.U. pistols, and a machine gun from Marvel's Agents of S.H.I.E.L.D. Agents donned vests, specialty pistols, and weapons. This lot consists of one padded black nylon tactical vest; one black plastic pistol holster; two modified black and silver-color urethane and metal airsoft pistols; one modified black, silver-color, and blue modified airsoft machine gun. A blaze orange plug was affixed to the end of each gun after production for sale as a collectible. The guns exhibit scuffing. Dimensions: (largest) 23" x 22" x 1" (58.5 cm x 56 cm x 2.75 cm) Ownership may be restricted in some countries; see replica firearm notice in Buyer's Guide.

**Estimate: \$2,500 - 5,000**

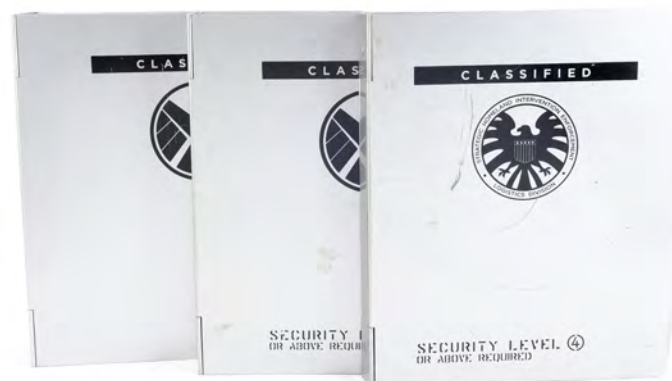

**987**  
**Set of Three S.H.I.E.L.D. Classified Binders with Paperwork and Stark Industries Schematics**  
**Marvel's Agents Of S.H.I.E.L.D. (2013-2020)**

Three S.H.I.E.L.D. classified binders with paperwork and Stark Industries schematics from Marvel's Agents of S.H.I.E.L.D. Classified documents were stored in binders throughout the series. This lot consists of three gray binders, each with the S.H.I.E.L.D. emblem and "Classified" printed in black on the front. One binder is labeled "Security Level 4" and another "Security Level 7." They contain paperwork, including polygraph examination files and service records. Five pages of Stark Industries schematics printed on cream-color paper are also included. The binders' exteriors exhibit scuffing and staining. Dimensions: (each) 12" x 12" x 3" (30.5 cm x 30.5 cm x 7.75 cm)

**Estimate: \$1,500 - 3,000**



**986**  
**Set of Nine Key Cast Chairbacks**  
**Marvel's Agents Of S.H.I.E.L.D. (2013-2020)**

Chairbacks for nine key cast members from Marvel's Agents of S.H.I.E.L.D. This set consists of black canvas chairbacks emblazoned "M.I.N.G. N.A.," "E.L.I.Z.A.B.E.T.H.," "H.E.N.R.Y.," "N.A.T.A.L.I.A.," "P.A.T.T.O.N.," "C.H.L.O.E.," "C.L.A.R.K.," "N.I.C.K.," and "I.A.I.N." in white text with matching color-printed production logos on their fronts. They exhibit some white staining and scuffing from production use. Dimensions: (each) 20.5" x 6.5" x 0.5" (52.25 cm x 16.5 cm x 1.5 cm)

**Estimate: \$1,500 - 3,000**



**988**  
**Phil Coulson's Badges, Eyeglasses, and Armband**  
**Marvel's Agents Of S.H.I.E.L.D. (2013-2020)**

Phil Coulson's badges, eyeglasses, and armband from Marvel's Agents of S.H.I.E.L.D. Agent Coulson wore glasses and different badges under his own name and aliases throughout the series. His robotic hand was attached at a metal band partway up his arm. This lot consists of one white and yellow plastic S.H.I.E.L.D. badge featuring Coulson's name and photo; one blue and white plastic clip-on Advocates for Mutual Justice badge with Coulson's photo and the name "Eric Greene"; dark brown and clear plastic eyeglasses with a tan leather case; and one urethane armband painted with chrome-color to simulate metal. The armband exhibits wear to its finish. Dimensions: (largest) 7" x 3" x 3" (17.75 cm x 7.75 cm x 7.75 cm)

**Estimate: \$1,500 - 3,000**



**989**  
**Set of Melinda May's S.H.I.E.L.D. Accessories**  
**Marvel's Agents Of S.H.I.E.L.D. (2013-2020)**

Melinda May's S.H.I.E.L.D. accessories from Marvel's Agents of S.H.I.E.L.D. Agent May wore her high-tech watch, goggles, and clip-on IDs throughout the series. This set consists of a non-functional rubber watch painted gray to appear metallic; black reflective plastic goggles with a matching case; an orange plastic "Level 7" S.H.I.E.L.D. ID featuring a picture of May and a metal waist clip; a red plastic S.H.I.E.L.D. access card; and a color photograph of May at the beach in a ribbed metallic frame. It exhibits scratching and scuffing throughout. Dimensions: (largest) 10" x 3" x 10" (25.5 cm x 7.75 cm x 25.5 cm)

**Estimate: \$1,500 - 3,000**



**991**  
**Five Sets of Phil Coulson's Captain America Cards with Alphonso "Mack" Mackenzie's Shotgun-Axe Accessories**  
**Marvel's Agents Of S.H.I.E.L.D. (2013-2020)**

Five sets of Phil Coulson's Captain America cards with Alphonso "Mack" Mackenzie's shotgun-axe accessories from Marvel's Agents of S.H.I.E.L.D. Mack wielded his shotgun-axe starting in Season 3, and Coulson collected vintage Captain America trading cards throughout the series. This lot consists of five sets of plastic-sealed color-printed trading cards; a black nylon shotgun-axe holster metal clips, a wedge cushion with fastening strips; five fake shotgun shells with fastening strips; a urethane blade with a metal clip and hard plastic cover; and nine silver-color and translucent blue Incapacitating Cartridge Emitting Railguns shells. The blade exhibits cracking and the I.C.E.R. shells exhibit adhesive residue. Dimensions: (largest) 16.5" x 16" x 4" (42 cm x 40.75 cm x 10.25 cm)

**Estimate: \$1,500 - 3,000**



**990**  
**Set of Melinda May's Leather Jackets and Boots**  
**Marvel's Agents Of S.H.I.E.L.D. (2013-2020)**

A set of Melinda May's leather jackets and boots from Marvel's Agents of S.H.I.E.L.D. May, one of S.H.I.E.L.D.'s most skilled agents, wore a variety of different leather jackets and boots when out of uniform throughout the series. This lot consists of one padded black zip-up leather jacket; one black leather and polyester-blend zip-up jacket; one dark red zip-up leather jacket marked "May 1 Cut"; black leather equestrian-style boots; and one pink production tag. The red jacket exhibits scuffing throughout from production.

**Estimate: \$1,500 - 3,000**



**992**  
**Lorelei's Battle-Damaged Asgardian Necklace with Broken Berserker Staff**  
**Marvel's Agents Of S.H.I.E.L.D. (2013-2020)**

Lorelei's battle-damaged Asgardian necklace with a broken Berserker staff from Marvel's Agents of S.H.I.E.L.D. In the Season 1 episode "Yes Men," Asgardian criminal Lorelei used her necklace to seduce Earth's men. Later, in "The Well," Norse paganists attempted to steal an ancient Asgardian staff. This lot consists of a 3-D-printed resin collar necklace painted gold-color, gilded with Asgardian patterns, and intentionally cracked by production to appear battle-damaged, as well as three steel- and gold-color resin staff pieces engraved with Norse runes and intentionally distressed to appear shattered. The necklace exhibits paint scuffing and exposed resin. Dimensions: (largest) 27" x 7" x 4" (68.75 cm x 18 cm x 10.25 cm)

**Estimate: \$2,000 - 4,000**



31" (78.75 cm)

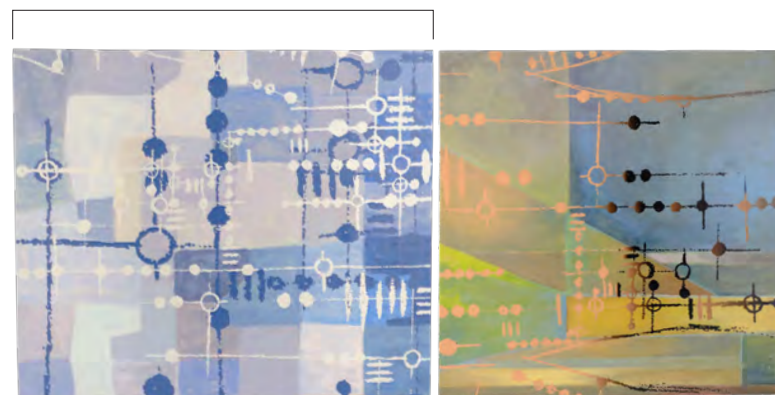

**993**  
 Pair of Janice Robbins' "T.A.H.I.T.I." Paintings  
**Marvel's Agents Of S.H.I.E.L.D. (2013-2020)**

Two of Janice Robbins' "T.A.H.I.T.I." paintings from Marvel's Agents of S.H.I.E.L.D. In the Season 2 episode "The Writing on the Wall," brainwashed former S.H.I.E.L.D. agent Robbins painted the same cryptic imagery Phil Coulson saw after Loki stabbed him. These paintings - one with blue and white runes and one with multicolor runes - are rendered in mixed media on wood-backed canvases. They exhibit some grime and edge wear from production use. Dimensions: (each) 30" x 31" x 1.5" (76.25 cm x 78.75 cm x 4 cm) Sold without copyright; see notice in the Buyer's Guide.

**Estimate: \$1,500 - 3,000**



**995**  
 Phil Coulson's Season 2 Finale Costume  
**Marvel's Agents Of S.H.I.E.L.D. (2013-2020)**

Phil Coulson's Season 2 finale costume from Marvel's Agents of S.H.I.E.L.D. In the episode "S.O.S. Part Two," Coulson wore his costume while retaking the Iliad from Jiaying's Inhumans. This lot consists of a gray wool-blend blazer marked "Coulson Hero"; matching trousers; a white cotton-blend button-up dress shirt monogrammed "CG"; a navy and white striped silk-blend necktie; black leather stunt dress shoes; a production-made, non-functional silver-color metal watch; a plastic Coulson S.H.I.E.L.D. ID; a gray and black urethane phone cover; a urethane armband painted with a chrome-color finish to resemble metal; and metalized sunglasses. This lot exhibits scuffs, scratches, and fraying from production.

**Estimate: \$2,000 - 4,000**

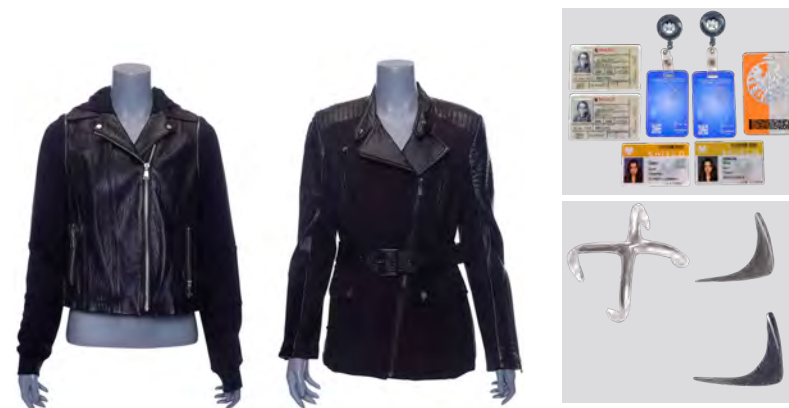

**994**  
 Pair of Daisy Johnson's  
 Leather Jackets and Accessories  
**Marvel's Agents Of S.H.I.E.L.D. (2013-2020)**

Daisy Johnson's leather jackets and accessories from Marvel's Agents of S.H.I.E.L.D. Johnson wore her leather jackets as vigilante "Quake" in Season 3 and used various IDs throughout the series. This lot consists of two black leather zip-up jackets, one with fleece sleeves; silver-color metal earrings; one X-shaped ring; multicolor plastic ID cards featuring the name "Skye," the S.H.I.E.L.D. logo, a color photo of Johnson, and basic information; four various multicolor ID cards; two nameless blue plastic S.H.I.E.L.D. logo ID cards; two laminated Department of Defence IDs with Johnson's photo and the alias "Maria Hill"; and two pink production tags. The lot exhibits production wear, including minor discoloration to the jewelry finish.

**Estimate: \$2,500 - 5,000**



**996**  
 Set of HYDRA and S.H.I.E.L.D. Accessories  
**Marvel's Agents Of S.H.I.E.L.D. (2013-2020)**

HYDRA and S.H.I.E.L.D. accessories from Marvel's Agents of S.H.I.E.L.D. Throughout the series, members wore outfits with accessories featuring the logos of their respective organizations. This lot consists of two plastic ID cards with color images of Grant Ward and Daisy Johnson and their names, Johnson using the name "Skye"; three metal HYDRA logo lapel pins; six embroidered HYDRA patches in two colors; and one sewn-fabric and two embroidered multicolor and multisize patches with the S.H.I.E.L.D. logo. The lot exhibits wear, loose threads in the patches, a tear in the sewn-fabric S.H.I.E.L.D. patch, and adhesive residue on the pinbacks.

**Estimate: \$2,500 - 5,000**



**997**  
 Set of Jemma Simmons and Leo Fitz's  
 S.H.I.E.L.D. IDs with Wedding Ring  
**Marvel's Agents Of S.H.I.E.L.D. (2013-2020)**

A set of Jemma Simmons and Leo Fitz's S.H.I.E.L.D. IDs with a wedding ring from Marvel's Agents of S.H.I.E.L.D. Both agents carried their IDs throughout the series, and eventually married each other. This lot consists of two orange and white plastic ID cards (one for Simmons and one for Fitz) featuring the S.H.I.E.L.D. logo, color photos of the agents, and basic information, housed in plastic carriers with metal clips; one blue and white S.H.I.E.L.D. Academy of Science and Technology ID card labeled for Simmons in a plastic case; an unmarked orange and white ID with a holographic logo; and a plain metal wedding band. The IDs exhibit some scuffing and staining from production. Dimensions: (largest) 4" x 2" (10.25 cm x 5.25 cm)

**Estimate: \$1,500 - 3,000**



**998**  
 Mike 'Deathlok' Peterson's  
 Light-Up Season 5 Costume  
**Marvel's Agents Of S.H.I.E.L.D. (2013-2020)**

Mike 'Deathlok' Peterson's light-up Season 5 costume from Marvel's Agents of S.H.I.E.L.D. Peterson aided Phil Coulson's sealing of the Fear Dimension portal. This costume features a multicolor zip-up compression suit with gray rubber shoulder and arm armor; a distressed gray and burgundy urethane and rubber vest marked "Stunt"; a battery-powered light-up belt; a resin left gauntlet painted silver-color and gray, affixed with magnets and battery-powered lights; black leather gloves with gray rubber accents marked "H"; and a black nylon belt. The lot includes a light blue wardrobe tag and two wardrobe bags. The costume exhibits scuffing on the gauntlet and vest, staining to the compression suit, and holes in the gloves, with the fingers removed from the right glove. Contains electronics; see electronics notice in the Buyer's Guide.

**Estimate: \$1,500 - 3,000**



**999**  
 Grant Ward's HYDRA Badge, Watch, and Phil Coulson  
 and Melinda May's S.H.I.E.L.D. IDs  
**Marvel's Agents Of S.H.I.E.L.D. (2013-2020)**

Grant Ward's HYDRA badge, watch, and Phil Coulson and Melinda May's S.H.I.E.L.D. IDs from Marvel's Agents of S.H.I.E.L.D. In Season 1's "The Magical Place," a watch-like device administered a neutralizing agent to soldiers; in Season 4's "What If...," Ward's Framework simulation operated as a double-agent; Coulson and May carried badges throughout the series. This lot consists of a black leatherette wallet featuring a HYDRA insignia and ID featuring a picture of Ward and biographical information; one silver-color metal watch-like piece with multicolor details and a rubber magnetic strap; and two plastic multicolor S.H.I.E.L.D. logo ID cards, color photos, and information in plastic, metal-clipped carriers. The HYDRA badge was ultimately unseen on screen. Included are detail pieces for the watch. The lot exhibits wear, including the leatherette cracking along its spine. Dimensions: (largest) 4.5" x 3.5" x 0.5" (11.5 cm x 9 cm x 1.5 cm)

**Estimate: \$3,000 - 6,000**



**1000**  
**Kitson Casino Sign and Poker Paraphernalia**  
**Marvel's Agents Of S.H.I.E.L.D. (2013-2020)**

A Kitson casino sign with poker paraphernalia from Marvel's Agents of S.H.I.E.L.D. In Season 6's episode "Fear and Loathing on the Planet of Kitson," Leo Fitz and Enoch gambled at a Kitson casino. This lot consists of one multicolor circular vinyl sign with Kitson's profile with edge holes for hanging, 200 multicolor urethane poker chips with holographic decals of Kitson's face; 25 multicolor cardstock betting slips; 46 multicolor acrylic alien chips; three numbered dice with foil accents; and a black cardboard box with a S.H.I.E.L.D. symbol on the front containing Kitson City playing card decks as crew gifts. The lot exhibits scratching, peeling decals, and edge denting. Dimensions: (largest) 44" x 44" (111.75 cm x 111.75 cm)

**Estimate: \$1,500 - 3,000**

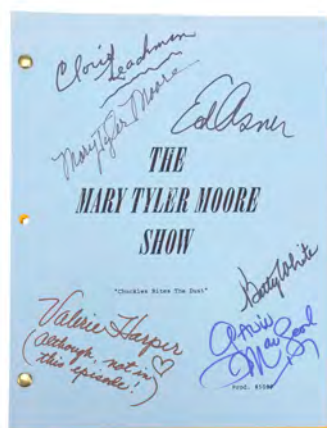

**1002**  
**Cast-Autographed "Chuckles Bites The Dust"**  
**Bound Script**  
**The Mary Tyler Moore Show (1970-1977)**

A cast-autographed "Chuckles Bites The Dust" bound script from the long running television sitcom, The Mary Tyler Moore Show. This brass brad-bound 43-page script was used in the making of the famous Season 6 episode "Chuckles Bites The Dust," which won a Primetime Emmy Award. This lot consists of one script featuring a blue cover with the show's title printed in black and "Prod. 5009." It features the autographs of Mary Tyler Moore, Cloris Leachman, Ed Asner, Gavin MacLeod, Betty White, and Valerie Harper. This lot exhibits staple holes, scratches on the page, and edgewear. Dimensions: 8.5" x 11" x 1" (22 cm x 28 cm x 2.5 cm)

**Estimate: \$1,200 - 2,400**



**1001**  
**Set of Daniel Sousa's Accessories**  
**Marvel's Agents Of S.H.I.E.L.D. (2013-2020)**

Daniel Sousa's accessories from Marvel's Agents of S.H.I.E.L.D. Agent Sousa, Peggy Carter's former flame, carried his accessories through time throughout Season 7. This set consists of a wooden cane with a gold-color grip; a brown classified 1950s-era S.H.I.E.L.D. personnel record folder with a black-and-white photograph of Sousa; two matching folders; and a brown leatherette wallet containing a metal S.H.I.E.L.D. badge and plastic ID labeled "Daniel Sousa." The paperwork exhibits creasing and edge wear, and the cane exhibits scuffing throughout from production. Dimensions: (largest) 35" x 10" x 2" (89 cm x 25.5 cm x 5 cm)

**Estimate: \$1,500 - 3,000**



**1003**  
**Eternian Soldier Uniform**  
**Masters Of The Universe (1987)**

An Eternian soldier uniform from Gary Goddard's fantasy adventure Masters of the Universe. Eternian soldiers wore their uniforms in the aftermath of the battle with Skeletor's (Frank Langella) army. This costume consists of a black-painted fiberglass helmet with an acrylic visor; black- and red-painted plastic chest armor marked "#15" with padded straps; a gray and navy cotton, suede, and leather jacket labeled "2113-1 Stock 45 36"; matching trousers labeled "2048-1 Stock 36 33"; gray suede gloves (8 1/2) with gray and blue plastic accents; a gray nylon belt with gray-painted resin details, and a urethane holster wrapped in gray leather; and gray-painted Adidas (11 1/2) with production added details. The costume exhibits major discoloration, a broken visor, and broken armor accessories.

**Estimate: \$2,000 - 4,000**



**1004**  
**Skeletor Trooper Blaster**  
**Masters Of The Universe (1987)**

A Skeletor trooper blaster from Gary Goddard's superhero film Masters of the Universe. Skeletor's (Frank Langella) troopers used blasters to seize control of Eternia and Castle Grayskull. This molded urethane pistol features a black plastic buckle component on one side next to a pair of circular details. Painted in dark gray with silver-color highlights, it also features bright red painted details and dark brown coloring along the barrel. Production intentionally distressed this weapon. It exhibits some broken molding, notable seams, notable paint marks, and some discoloration. Dimensions: 16" x 7" x 2" (40.75 cm x 18 cm x 5 cm)

**Estimate: \$1,000 - 2,000**



**1006**  
**Sentinel Claw**  
**The Matrix Reloaded (2003)**

A sentinel claw from Lana and Lilly Wachowski's sci-fi sequel The Matrix Reloaded. Dangerous machines known as sentinels served the Matrix in the real world by patrolling the ravaged planet in search of humans. This sentinel claw is constructed of foam and painted black and silver-color over a metal armature. It exhibits paint chipping and cracking in the foam. Dimensions: 20" x 22" x 5" (51 cm x 56 cm x 12.75 cm)

**Estimate: \$1,000 - 2,000**



**1005**  
**Big Cop's (Bernie Ledger) SFX Broken Arm Rig**  
**The Matrix (1999)**

Big Cop's (Bernie Ledger) SFX broken arm rig from the Wachowskis' sci-fi action film The Matrix. Trinity (Carrie-Ann Moss) viciously broke the arm of a police officer who attempted to handcuff her in the Matrix. Created for the SFX insert of the arm breaking, this rig consists of a hard rubber hand-painted peach mounted to a foam rubber arm molded around a metal armature inlay dressed with a white Spandex sleeve. The arm is affixed with a contoured, swiveling plastic shoulder rig with black nylon straps alternately labeled "A" and "B" which raise and lower the hand independently from the arm. The rig exhibits aging to the foam rubber elements, tears in the sleeve, and frayed nylon from production use. Dimensions: 26" x 20" x 8" (66 cm x 51 cm x 20.5 cm) Contains mechanical components; see mechanical notice in the Buyer's Guide.

**Estimate: \$2,000 - 4,000**



**1007**  
**Pair of L. Dean Jones, Jr.'s Bound Shooting Scripts**  
**The Matrix Reloaded (2003)/The Matrix Revolutions (2003)**

Pair of L. Dean Jones, Jr.'s bound shooting scripts from the production of the Wachowskis' sci-fi sequels The Matrix Reloaded and The Matrix Revolutions. This lot comes from the collection of The Matrix Reloaded and Revolutions production manager L. Dean Jones, Jr. The 133-page numbered shooting script for Reloaded is dated "October 27, 2001," bound with brass brads, and watermarked throughout for Jones. The 133-page Revolutions script is dated "October 27, 2000," bound with brass brads, watermarked throughout for Jones, and hand-marked "Rec'd 11/17/00" on the front cover. Both exhibit minor edge wear from handling. Dimensions: (each) 11" x 9" x 1" (28 cm x 23 cm x 2.5 cm)

**Estimate: \$800 - 1,600**



**1008**  
Set of Five Production Binders  
**The Matrix Trilogy (1999-2003)**

Five production binders from the production of the Wachowskis' The Matrix trilogy. The binders in this lot contain digital prints of concept designs hand-annotated by concept illustrator George Hull during production. This lot comes from the collection of The Matrix Reloaded and Revolutions production manager L. Dean Jones, Jr. These five plastic binders labeled "Sentinels" and "Armored Personnel Units" contain 145 pages of production paperwork watermarked for Jones and 25 continuity photos taped to manila folders. Both the binders and paperwork exhibit grime from age and production use, as well as bent and torn pages. Dimensions: (largest) 19" x 12" x 1.5" (48.5 cm x 30.5 cm x 4 cm)

**Estimate: \$2,000 - 4,000**



**1010**  
Set of Three Model Production Binders  
**The Matrix Trilogy (1999-2003)**

Three model production binders from the production of the Wachowskis' The Matrix trilogy. The binders contain print-outs of digital artwork, photographs, and reference imagery regarding the creation of physical sets and models. This lot comes from the collection of The Matrix Reloaded and Revolutions production manager L. Dean Jones, Jr. These three plastic binders with such labels as "Physical Models: APV/Digger," "Physical Models: Sentinel," and "Door," among others, contain 550 pages of paperwork watermarked throughout for Jones. The paperwork exhibits grime from age and production use. Dimensions: (largest) 11.5" x 11.5" x 3.5" (29.25 cm x 29.25 cm x 9 cm)

**Estimate: \$2,000 - 4,000**

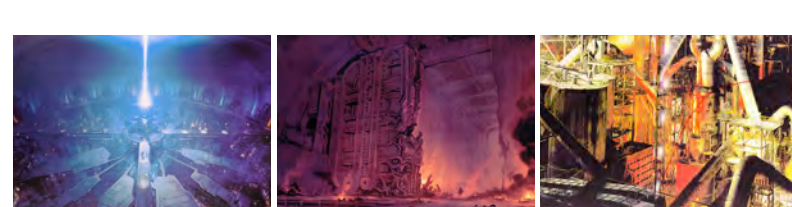

**1009**  
Set of 19 Production Binders  
**The Matrix Trilogy (1999-2003)**

19 binders from the production of the Wachowskis' The Matrix trilogy. The binders contain digital prints of reference images and set and concept designs by concept illustrator George Hull, concept artist Marc Gabbana, concept artist Brian Flora, and CA foreman Aaron Haye. This lot comes from the collection of The Matrix Reloaded and Revolutions production manager L. Dean Jones, Jr. These 19 plastic binders with such labels as "Digger 2," "Mjolnir Crash Landing Platforms," and "Control Tower," among others, contain 925 pages of production paperwork watermarked for and hand-annotated by Jones. Both the binders and paperwork exhibit grime, bending, and tearing from age and use. Dimensions: (largest) 19" x 12" x 1.5" (48.5 cm x 30.5 cm x 4 cm)

**Estimate: \$1,500 - 3,000**



**1011**  
Set of Three Annotated Storyboard and Previsualization Production Binders  
**The Matrix Trilogy (1999-2003)**

Three annotated storyboard and previsualization binders from the production of the Wachowskis' The Matrix trilogy. The binders contain print-outs of digitally-rendered storyboards of the Zion siege sequence, previsualization cut orders, and mini-boards. This lot comes from the collection of The Matrix Reloaded and Revolutions production manager L. Dean Jones, Jr. These three plastic labeled binders contain 518 pages watermarked for and hand-annotated throughout by Jones. Both the binders and paperwork exhibit grime from age and use. Dimensions: (largest) 11.5" x 11.5" x 3.5" (29.25 cm x 29.25 cm x 9 cm)

**Estimate: \$2,000 - 4,000**

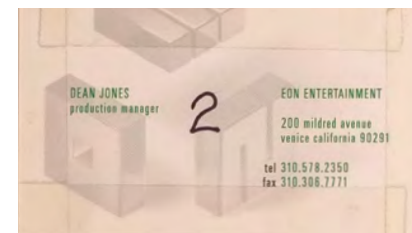

**1012**  
Set of Three "Dog and Pony" Production Binders  
**The Matrix Trilogy (1999-2003)**

Three "Dog and Pony" binders from the production of the Wachowskis' The Matrix trilogy. Binders featuring printed digital concept designs by concept artist Marc Gabbana were created for "Dog and Pony" presentations held to showcase conceptual ideas to various departments and VFX houses. This lot comes from the collection of The Matrix Reloaded and Revolutions production manager L. Dean Jones, Jr. These three plastic binders labeled "Dog and Pony Show and Tell," "Conceptuals, Omits," and "II and III Concept" contain 423 pages of paperwork watermarked for Jones, and two compact discs of EFX shots and jpegs. The paperwork exhibits grime, bending, and minor tears. Dimensions: (largest) 11.5" x 11.5" x 3.5" (29.25 cm x 29.25 cm x 9 cm)

**Estimate: \$2,000 - 4,000**



**1013**  
Mikey's (John Alexander)  
Alien Hand and Foot Appliances  
**Men In Black (1997)**

Mikey's (John Alexander) alien hand and foot appliances from Barry Sonnenfeld's sci-fi action comedy Men in Black. Agent K (Tommy Lee Jones) exposed Mikey when the alien tried to sneak over the U.S./Mexico border. Created by Rick Baker and his team, this lot consists of two hand-painted foam rubber hand appliances, each with an armatured thumb and a metal and fiberglass interior mechanism designed to articulate three oversize fingers, as well as two matching foam-padded rubber and cotton shoes appliances with added heel extensions and three oversize toes. Each appliance exhibits cracking to the foam and flaking paint from production use. Contains mechanical components; see notice in the Buyer's Guide.

**Estimate: \$1,000 - 2,000**



**1014**  
Pair of Fin Blasters  
**Men In Black II (2002)**

A pair of fin blasters from Barry Sonnenfeld's action comedy Men in Black II. Agent Kay and Agent Jay went to Agent Kay's former apartment to acquire weapons to rescue Laura from Serleena. This lot consists of two static, futuristic-looking rubber foam blasters. Painted a silver-color, these blasters feature a top holed ridge and vents at the back of the frame painted bright green. This lot exhibits notable marks, cracking and pitting, and notable paint marks. Dimensions: (each) 23" x 7" x 2" (58.5 cm x 18 cm x 5 cm)

**Estimate: \$3,000 - 6,000**

# Day 3

Lots 1015 - 1487.  
June 30, 2023

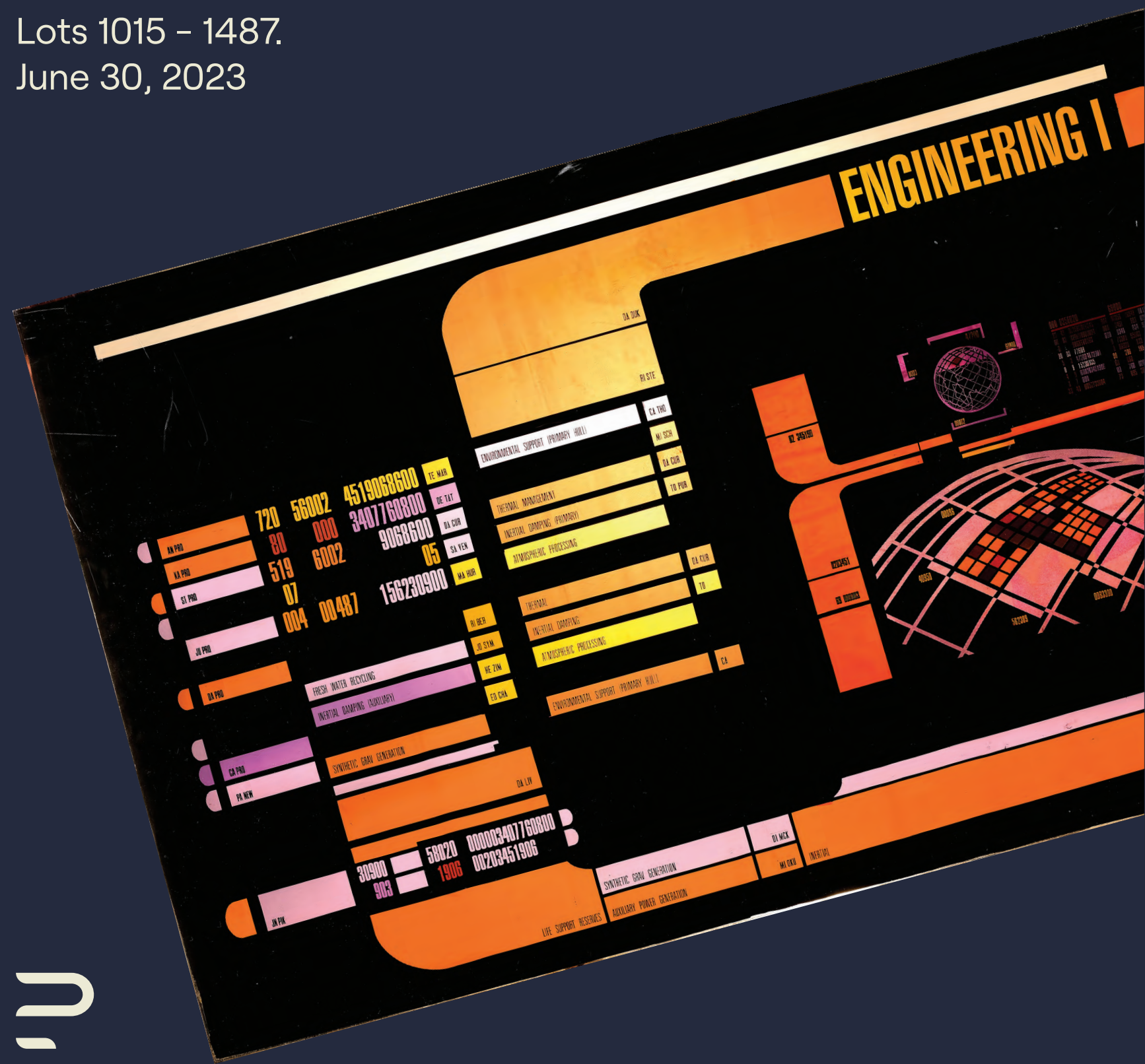

**1015**  
Set of Eight Clear Folders  
with Logo  
**Men In Black II (2002)**

A set of eight clear folders with logos from Barry Sonnenfeld's action comedy Men in Black II. Throughout the Men in Black agency, agents used file folders for the various alien cases they encountered. This lot consists of eight clear polypropylene folders featuring a sticker of the organization's logo in black and a black plastic secure clip. One of the folders features 10 pages of astronomical study, and one folder features 15 pages of study. This lot exhibits minor wear from production use and age. Dimensions: (each) 11.75" x 9" x 0.25" (30 cm x 23 cm x 0.75 cm)

**Estimate: \$600 - 1,200**



**1016**  
Goldar Alien Cowl  
**Men In Black 3 (2012)**

A Goldar alien cowl from Barry Sonnenfeld's sci-fi comedy-action sequel Men in Black 3. The black and gold-skinned alien, Goldar, was seen in the Men in Black headquarters early in the film. Designed by legendary makeup artist Rick Baker, this lot consists of one cowl. It is made of foam latex painted gold-color with flecks of black and brown to create dimension. This appliance features a nylon neck lining and an extended neck sculpt painted in shades of black to appear like clothing. This lot exhibits mild tearing, discoloration, minor flaking, and foam fragility. Dimensions: 13" x 17" x 12.5" (33 cm x 43.25 cm x 31.75 cm)

**Estimate: \$1,500 - 3,000**



**1017**  
Red Fish Alien Mask and Gloves  
**Men In Black 3 (2012)**

A red fish alien mask and gloves from Barry Sonnenfeld's sci-fi comedy-action sequel Men in Black 3. Agent J (Will Smith) encountered many alien species in MIB's 1969 Headquarters as he partnered with a younger version of Agent K (Josh Brolin). Designed by legendary makeup artist Rick Baker, this lot consists of one mask and a pair of gloves. Made of rubber, silicone, and nylon, this appliance features a fish-like design with bulging squinted eyes painted in shades of red and orange. The gloves feature three large digits. This lot exhibits minor flaking, and foam fragility. Dimensions: 13" x 17" x 12.5" (33 cm x 43.25 cm x 31.75 cm)

**Estimate: \$1,500 - 3,000**



\*Certain films and shows have Lots offered on more than one day of the Auction; see Index on page 706 for a complete listing of available Lots by film or show title



**1018**  
The Sphinx, St. Basil's Cathedral and Taj Mahal Model Miniatures  
**Michael Jackson:**  
**Black Or White (1991)**

The Sphinx, St. Basil's Cathedral, and Taj Mahal model miniatures from Michael Jackson's music video Black or White. Jackson sang and danced at exotic locales with the assistance of compositing. These landmarks are made in scaled-model form by effects house Matte World Digital. The miniatures are made of resin, fiber board, and plastic, each painted in the style and color schemes of the actual architectural landmarks. This lot exhibits paint chipping, and the Taj Mahal model exhibits loose and missing pieces. Dimensions: (largest) 36" x 36" x 40" (91.5 cm x 91.5 cm x 101.75 cm)

**Estimate: \$1,000 - 2,000**

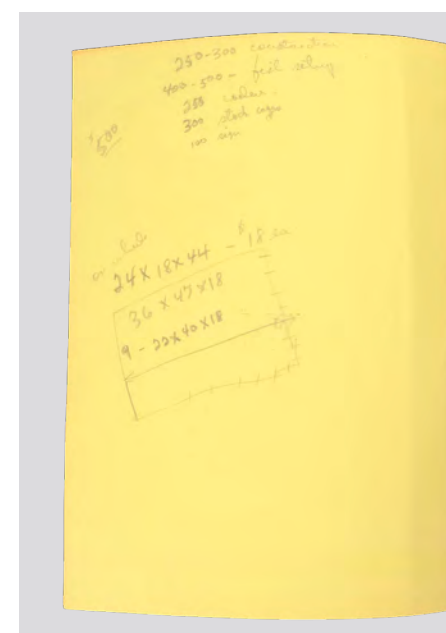
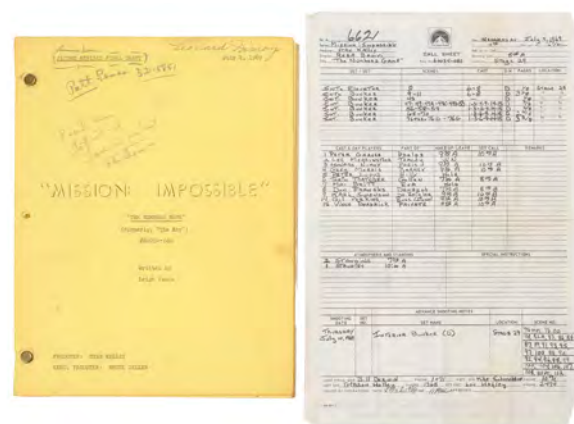

**1019**  
Leonard Nimoy's Personal Annotated Second Revised Final Draft Script with Two Call Sheets  
**Mission: Impossible (1966-1973)**

Leonard Nimoy's personal, annotated second revised final draft script with two call sheets from Season 4's episode "The Numbers Game" of the series Mission: Impossible. This lot, originally sourced from Leonard Nimoy's assistant Teresa Victor, consists of a brass brad-bound, 56-page second revised final draft script hand-marked for Nimoy in the top right corner, dated "July 2, 1969," and annotated throughout in pencil; and two white printed call sheets hand-marked "Mission Impossible" and dated for shoot days in July 1969. Nimoy marked the script cover with his name and made notes throughout the script. It exhibits staining and the call sheets exhibit corner creasing and fold lines. Dimensions: 8.5" x 11" x 0.5" (21.75 cm x 28 cm x 1.5 cm)

**Estimate: \$2,000 - 4,000**



**1020**  
Owen Davians' (Philip Seymour Hoffman) Charge Gun With Case  
**Mission: Impossible III (2006)**

Owen Davians' (Philip Seymour Hoffman) charge gun with a case from J.J. Abrams 2006 spy sequel, Mission: Impossible III. Davian planted an explosive charge in Ethan Hunt's (Tom Cruise) head. Housed in an aluminum briefcase with custom foam inserts, this lot consists of one stainless steel gun. The case also contains one hollow needle; a two-pronged attachment; two additional attachments; five resin charges; and a resin vial. This lot exhibits scuffing on the case and gun, and a yellowing of the resin components. Dimensions: 14" x 12" x 4" (35.5 cm x 30.5 cm x 10.25 cm)

**Estimate: \$3,000 - 6,000**



**1021**  
David Drayton's (Thomas Jane) Screen-Matched License Plate Display  
**The Mist (2007)**

David Drayton's (Thomas Jane) license plate display from Frank Darabont's 2007 sci-fi horror The Mist. This plate screen-matches to the back of Drayton's van when the mist's survivors attempted to gather medical supplies. This white aluminum Maine license plate numbered "M8 270Q" is affixed with "DEC" and "MAINE 08" decals on front and labeled "David" on the reverse with metal screws glued into its top holes. It comes inside a custom-made wood display case with an acrylic cover and two stills from the film. The plate exhibits intentional red grime applied by production. Dimensions: 21.75" x 20" x 3" (55 cm x 50.5 cm x 7.25 cm)

**Estimate: \$1,000 - 2,000**



**1022**  
Colonel Jason Grant's (Walter Koenig) Spacesuit Costume  
**Moontrap (1988)**

Colonel Jason Grant's (Walter Koenig) spacesuit from Robert Dyke's sci-fi film Moontrap. Jason wore his spacesuit while he explored the moon and space. This costume consists of a soft padded helmet made of white canvas with a clear acrylic visor and two non-functional resin lights; a plastic and foam collar with canvas covering and metal hardware; a padded canvas long-sleeve torso top with a patch on each arm; padded canvas bottom trousers; canvas gloves with a leather palm and rubber fingertips hand marked "Walter"; and shoes with canvas boot covers. The costume interior and boots feature tags from Center Theatre Group with "Moontrap Walter Koenig" hand-marked in black ink. This lot exhibits a build up of grime, discoloration, and fragile components due to age.

**Estimate: \$3,500 - 7,000**



**1023**  
Lunar Roving Vehicle with Ray Tanner (Bruce Campbell) Model Miniature  
**Moontrap (1988)**

A lunar roving vehicle with a Ray Tanner (Bruce Campbell) model miniature from Robert Dyke's sci-fi film Moontrap. This model miniature was used when Tanner drove the lunar rover to explore the moon's surface. This lot consists of a red-, white-, black- and gray-painted plastic roving vehicle with painted foam wheels, metal mesh accessories, foil covered styrofoam details, and a black-and-white painted foam Tanner figurine in his spacesuit. This lot exhibits falling off pieces and the figurine is missing its head. Dimensions: 22" x 13" x 12" (56 cm x 33 cm x 30.5 cm)

**Estimate: \$1,500 - 3,000**



**1024**  
Colonel Jason Grant (Walter Koenig)  
and Mera (Leigh Lombardi) Model Miniatures  
**Moontrap (1988)**

Colonel Jason Grant (Walter Koenig) and Mera (Leigh Lombardi) model miniatures from Robert Dyke's sci-fi film Moontrap. Mera clung to Jason as they jettisoned out of the Kaalium ship. This lot consists of two foam model miniatures attached to each other. They feature hollowed bodies with limb armatures, and house a small battery pack that powered the miniatures' head movements. The Jason miniature is without a head. This lot exhibits missing components, cut wires, fragile foam, and chipped and peeling paint. Dimensions: 7" x 11.5" x 5.5" (18 cm x 29.25 cm x 14 cm) Contains electronics; see electronics notice in the Buyer's Guide.

**Estimate: \$1,000 - 2,000**



**1026**  
Colonel Jason Grant (Walter Koenig)  
with MMU Model Miniature  
**Moontrap (1988)**

A Colonel Jason Grant (Walter Koenig) with MMU model miniature from Robert Dyke's sci-fi film Moontrap. Grant used his Manned Maneuvering Unit (MMU) to investigate a derelict ship found floating in space. This lot consists of a hollow-bodied foam and resin model miniature with armatures in the limbs and a small battery pack designed to power the miniature's head movements inside. Also included are two threaded metal bars for mounting the MMU to the model. This lot exhibits chipping, peeling paint, and fragile foam. Dimensions: 12" x 5.5" x 8.5" (30.5 cm x 14 cm x 21.5 cm) Contains electronics; see electronics notice in the Buyer's Guide.

**Estimate: \$1,000 - 2,000**



**1025**  
Space Shuttle Camelot Model Miniature  
**Moontrap (1988)**

Space Shuttle Camelot model miniature from Robert Dyke's sci-fi film Moontrap. It was used when Colonel Jason Grant (Walter Koenig) and Ray Tanner (Bruce Campbell) flew in space. This lot consists of a white- and black-painted plastic space shuttle featuring the USA flag on and "United States NASA Camelot" in vinyl and black vinyl detailing. A metal bolt in the engines allowed the model to spin on set and the top detaches exposing the wood interior and electrical wires. It exhibits peeling vinyl and grime. Dimensions: 19.5" x 13" x 8" (49.75 cm x 33 cm x 20.5 cm) Contains electronics; see electronics notice in the Buyer's Guide.

**Estimate: \$1,000 - 2,000**



**1027**  
Kaalium Model Miniature  
**Moontrap (1988)**

A Kaalium model miniature from Robert Dyke's sci-fi film Moontrap. The Kaalium descended from the ceiling and prepared to dismember Colonel Jason Grant (Walter Koenig) and Mera (Leigh Lombardi). This lot consists of one model miniature made of foam, resin, wood, wires, and metal armature painted in metallic colors for mechanical parts and off-white and red-tones for the raw organic parts. This miniature features a detailed spine sculpt. This miniature comes on a square wooden stand. It has undergone sympathetic repair. This lot exhibits flaked paint, exposed foam, and fragility. Dimensions: 9" x 6.5" x 4" (23 cm x 16.5 cm x 10.25 cm)

**Estimate: \$800 - 1,600**



**1028**  
Ray Tanner's (Bruce Campbell) Model Miniature  
**Moontrap (1988)**

A Ray Tanner's (Bruce Campbell) model miniature from Robert Dyke's sci-fi film Moontrap. Ray rode around on his rover on the moon for a search-and-destroy mission. This lot consists of one model miniature astronaut made from a 3.75" G.I. Joe Lightfoot action-figure that was modified with sculpting clay and painted in white, red, blue, and black. Featuring articulate joints for easy posing, this miniature has metal screws. This lot exhibits chipped and peeling paint. Dimensions: 4.25" x 4.25" x 2" (10.5 cm x 10.5 cm x 5 cm)

**Estimate: \$200 - 400**

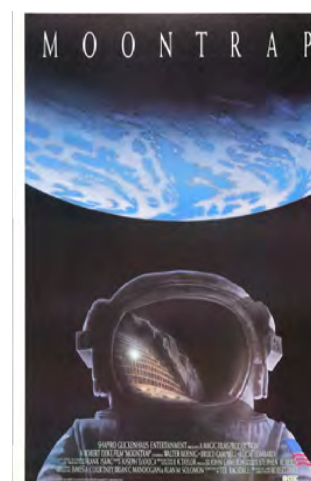

**1030**  
Poster  
**Moontrap (1988)**

A poster from the promotion of Robert Dyke's sci-fi film Moontrap. Shapiro Glickenhau Entertainment commissioned posterist Tom Jung, best known for designing promotional art for Raiders of the Lost Ark and the Star Wars franchise, to create this poster with art referencing spacesuits seen in the film. Only four original full-size posters of this style are still known to exist.

This poster depicting an astronaut facing a community on the moon is printed with Jung's signature and the credits list at the bottom. It exhibits minor stains along the edges and creasing from being rolled for storage. Dimensions: 27" x 41" (68.75 cm x 104.25 cm)

**Estimate: \$800 - 1,600**



**1029**  
Colonel Jason Grant (Walter Koenig) Model Miniature  
**Moontrap (1988)**

A Colonel Jason Grant (Walter Koenig) model miniature from Robert Dyke's sci-fi film Moontrap. The Kaalium took Jason and Mera (Leigh Lombardi) prisoner while they were trapped on the moon. This lot consists of one foam and resin model miniature. It features a hollowed body with armatures in the limbs and houses a small battery pack that powered the miniature's head movements. It features a clear space helmet visor to see Jason's face. This lot exhibits fragile foam, exposed armatures, chipped and peeling paint, and signs of minor restoration where the hand was reattached. Dimensions: 12" x 6" x 4.5" (30.5 cm x 15.25 cm x 11.5 cm) Contains electronics; see electronics notice in the Buyer's Guide.

**Estimate: \$600 - 1,200**

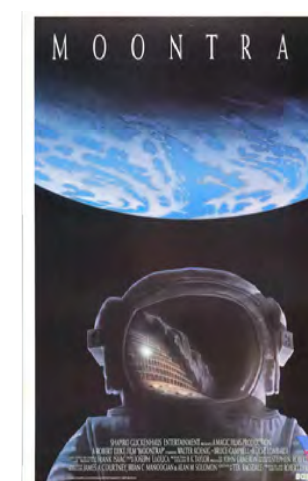

**1031**  
Poster  
**Moontrap (1988)**

A poster from the promotion of Robert Dyke's sci-fi film Moontrap. Shapiro Glickenhau Entertainment commissioned posterist Tom Jung, best known for designing promotional art for Raiders of the Lost Ark and the Star Wars franchise, to create this poster with art referencing spacesuits seen in the film. Only four original full-size posters of this style are still known to exist.

This poster depicting an astronaut facing a community on the moon is printed with Jung's signature and the credits list at the bottom. It exhibits minor stains along the edges and creasing from being rolled for storage. Dimensions: 27" x 41" (68.75 cm x 104.25 cm)

**Estimate: \$800 - 1,600**



**1032**  
Collection of Fighters' Accessories  
**Mortal Kombat (1995)**

Fighters' accessories from Paul W. S. Anderson's fantasy action film *Mortal Kombat*. Sonya Blade (Bridgette Wilson), Johnny Cage (Linden Ashby), Scorpion (Chris Casamassa), and Reptile (Keith Cooke) competed against each other in mortal combat. This lot consists of a two-piece metal and plastic Sonya Blade Glock 17L applied with clear resin resembling ice; a rubber Reptile mask attached to a black nylon balaclava; a foam Scorpion spear tip painted to resemble a creature's head with an internal metal rod; and a tabloid newspaper cover headlined "Johnny Cage a Fake!" with an image of Cage in front of a bluescreen. This lot exhibits chipping, folded corners, minor rips and tears, and blemishes on the gun barrel. Dimensions: 12" x 10" x 12" (30.5 cm x 25.5 cm x 30.5 cm)

**Estimate: \$3,000 - 6,000**



**1033**  
John Smith's (Brad Pitt) Headpiece  
**Mr. & Mrs. Smith (2005)**

John Smith's (Brad Pitt) headpiece from Doug Liman's action comedy *Mr. & Mrs. Smith*. John wore his headpiece while he crawled through the pipes on his way to kidnap Danz (Adam Brody). This lot consists of one plastic headset with a rubber ear piece and a polyurethane camera. The camera features metal components and static multicolored buttons. This lot exhibits worn elastic and a buildup of grime, as well as scratches and divots in the plastic. Dimensions: 8" x 6" x 3" (20.5 cm x 15.25 cm x 7.75 cm)

**Estimate: \$1,500 - 3,000**



**1034**  
Jane Smith's (Angelina Jolie)  
"Jesus Rocks" Jacket  
**Mr. & Mrs. Smith (2005)**

Jane Smith's (Angelina Jolie) "Jesus Rocks" jacket from Doug Liman's action comedy *Mr. & Mrs. Smith*. John (Brad Pitt) and Jane Smith stole the Colemans' minivan to escape their assassins and wore clothes found in the vehicle to meet with Eddie (Vince Vaughn) at a diner, with Jane donning the stolen jacket of Suzi Coleman (Rachael Huntley). This lot consists of a black satin letterman-style jacket with knit hems and neon pink piping on the jacket and sleeves on a dry cleaner's hanger. The jacket features embroidery on the chest with the name "Suzi" in calligraphy on one side and "Jesus Rocks" with an image of Jesus beneath it on the other. The back features "Jesus Rocks 2001 U.S. Tour" also in embroidery. This lot exhibits minor thread snagging on the embroidery, tearing on the paper cover, and rips on the plastic bag.

**Estimate: \$1,200 - 2,400**



**1035**  
John Smith's (Brad Pitt)  
"Jesus Rocks" Jacket  
**Mr. & Mrs. Smith (2005)**

John Smith's (Brad Pitt) "Jesus Rocks" jacket from Doug Liman's action comedy *Mr. & Mrs. Smith*. John and Jane Smith (Angelina Jolie) stole the Colemans' minivan to escape their assassins and wore clothes found in the vehicle to meet with Eddie (Vince Vaughn) at a diner, with John donning the stolen jacket of Martin Coleman (Chris Weitz). This lot consists of a black satin letterman-style jacket with knit hems and neon pink piping on the jacket and sleeves on a dry cleaner's hanger. The jacket features embroidery on the chest with the name "Martin" in calligraphy on one side and "Jesus Rocks" with an image of Jesus beneath it on the other. The back features "Jesus Rocks 2001 U.S. Tour" also in embroidery. This lot exhibits minor thread snagging on the embroidery, tearing on the paper cover, and rips on the plastic bag.

**Estimate: \$1,200 - 2,400**



**1036**  
Book of Amun-Ra Lock  
**The Mummy (1999)**

A Book of Amun-Ra lock from Stephen Sommers' action-adventure *The Mummy*. Known as the "Book of the Living," it was discovered by Rick O'Connell (Brendan Fraser), Jonathan Carnahan (John Hannah) and Ardeth Bay (Oded Fehr). A locking mechanism adorns the book's cover. This cast resin lock is painted dark gray with bits worn revealing a gold-color underlayer, has an intricately patterned border, an embedded sun-shaped emblem where a key would be inserted, and an eye insignia. The underside exhibits cracking. Dimensions: 7" x 7" x 0.5" (18 cm x 18 cm x 1.5 cm)

**Estimate: \$1,000 - 2,000**



**1037**  
Rick O'Connell's  
(Brendan Fraser) Shoes  
**The Mummy Returns (2001)**

Rick O'Connell's (Brendan Fraser) shoes from the production of Stephen Sommers' action-adventure sequel *The Mummy Returns*. Rick wore his shoes in London and Egypt to rescue his son. This lot consists of custom-made ankle boots. Made of brown leather with rubber soles and brown eyelets, these lace-up boots feature hand-marked tags near the ankles: an encircled "1" in black marker, and the letter "B." Hand-marked in red ink is "4304" and "Mr. Fraser." This lot exhibits scuffing on the leather; creasing along the toe; worn out soles; pitting and damage on the heel and midsole; notable glue residue; and discoloration. Dimensions: 17" x 17" x 8" (43.25 cm x 43.25 cm x 20.5 cm)

**Estimate: \$2,000 - 4,000**



**1038**  
**The Emperor's (Jet Li) Sword and Sheath**  
**The Mummy: Tomb Of The Dragon Emperor (2008)**

The Emperor's (Jet Li) sword and sheath from Rob Cohen's action-adventure sequel The Mummy: Tomb of the Dragon Emperor. Han, the Dragon Emperor raised from the dead as a mummy, wielded his signature sword throughout the film. This lot originated from Cohen's personal collection. It consists of a two-tone metal sword engraved with dragon emblems, featuring an ornate faux gold handle wrapped with rust-color twine, inset with faux rubies, and a dragon-patterned green fiberglass and resin sheath wrapped with brown leather cord. The blade exhibits scratching, nicks, and a stain on the handle from production use. Dimensions: (sheathed) 33" x 4" x 4" (84 cm x 10.25 cm x 10.25 cm) Blade was dulled by production.

**Estimate: \$3,000 - 6,000**



**1039**  
**John Chambers Collection: Olga the Dancing Bear's**  
**(Janos Prohaska) Head**  
**The Munsters (1964-1966)**

Olga the Dancing Bear's (Janos Prohaska) head from the family sitcom The Munsters. In Season 2's "Herman's Child Psychology," Herman Munster (Fred Gwynne) brought home a bear that escaped from the circus. This foam head comes from the collection of makeup artist John Chambers, who created prosthetics throughout the series. It is dressed with synthetic mesh, applied with synthetic black bear fur with a neck opening, and a nose and teeth hand-painted black and white. It exhibits internal discoloration and fraying hair from production use and age. Dimensions: 10" x 10" x 11" (25.5 cm x 25.5 cm x 28 cm)

**Estimate: \$600 - 1,200**



**1040**  
**Sam the Eagle's (Frank Oz) Alarm Clock**  
**Muppets From Space (1999)**

Sam the Eagle's (Frank Oz) alarm clock from Tim Hill's sci-fi comedy Muppets from Space. Sam turned off his alarm when he pushed down the eagle upon waking. Originating from a source close to production, this mechanical gold-color alarm clock is made of metal and glass, and features a blue clock face with two gold-color hands, a gold-color resin eagle poised on top, and various knobs on the back to wind up the clock and set the time. This lot exhibits flaked paint and some scratches. Dimensions: 5" x 3.5" x 9" (12.75 cm x 9 cm x 23 cm) Contains mechanical components; see notice in the Buyer's Guide.

**Estimate: \$1,000 - 2,000**

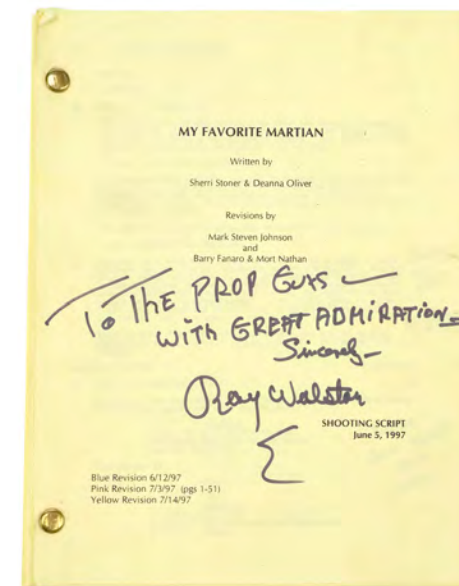

**1041**  
**Ray Walston-Autographed**  
**Annotated Bound Script with**  
**Spaceship Model Miniature**  
**My Favorite Martian (1999)**

A Ray Walston-autographed annotated bound script with spaceship model miniature from Donald Petrie's sci-fi comedy My Favorite Martian. The Martian (Christopher Lloyd) shrunk his spaceship to keep it concealed from Tim O'Hara (Jeff Daniels). This lot consists of one script and one model miniature spaceship with an aluminum display. The epoxy resin and wood model spaceship was painted in reds and shades of metallic silver-color. The 115-page shooting script dated "June 5, 1997" features Ray Walston's autograph in black marker and hand-marked annotations throughout. The model has undergone sympathetic repair. This lot exhibits chips, cracks, and creased corners. Dimensions: 12" x 11" x 11" (30.5 cm x 28 cm x 28 cm)

**Estimate: \$1,500 - 3,000**



**1042**  
**Book of Secrets'**  
**Papers and Articles**  
**National Treasure:**  
**Book Of Secrets (2007)**

Book of Secrets' papers and articles from Jon Turteltaub's action-adventure film National Treasure: Book of Secrets. Ben Gates (Nicholas Cage) located the President's Book of Secrets at the Library of Congress filled with articles and entries from previous presidents. This lot consists of various page inserts for the President's Book: four torn newspaper articles; nine black-and-white and color images of the moon landing and President Kennedy with handwritten notes; three blue FBI Wanted flyers; 25 paper and vellum White House letterheads; one map; and 10 top secret documents. This lot exhibits production made distressing on the pages throughout and fold creases. Dimensions: (extended) 18" x 10.5" (45.75 cm x 26.75 cm)

**Estimate: \$1,500 - 3,000**



**1043**  
**Cibola Knife**  
**National Treasure:**  
**Book Of Secrets (2007)**

A Cibola knife from Jon Turteltaub's action-adventure sequel National Treasure: Book of Secrets. Mitch Wilkinson (Ed Harris) took a knife from a stabbed skeleton when he scouted ahead in the Cibola ruins to later use against Abigail Chase (Diane Kruger). This lot consists of a teal resin carved knife featuring a red-painted tip and a gold-color painted sculpted handle with brown leather wrapped around it. This lot exhibits distressing, glue residue to the leather, and minor paint chipping. Dimensions: 13" x 2.5" x 2.5" (33 cm x 6.5 cm x 6.5 cm)

**Estimate: \$3,000 - 6,000**





**1044**  
Crew Jacket, Call Sheets, and Production Paperwork  
**THE NATURAL (1984)**

A crew jacket with call sheets and production paperwork from Barry Levinson's sports drama *The Natural*. The letterman-style jacket (hand-marked size 2XL) features a navy blue wool shell with contrasting tan leather sleeves with two front pockets; a blue and orange New York Knights logo embroidered and sewn to the left breast; "The Natural" embroidered in orange and white on the reverse; a snap-button closure; and wrist, waist, and neck stretch bands. The paperwork is divided between a green paper folder and a white legal-size envelope. The folder includes 20 call sheets; a 17-page De Forest Research report on the original novel; a 4-page photocopy of wardrobe notes; a photocopy of New York Knights' emblem embroidery instructions; a photocopied magazine article page; and a black-and-white photo of a young boy. The envelope includes a production budget hand-printed in blue with four lined yellow pages itemizing the expenditures in pencil and stapled with a white accounting receipt. The jacket exhibits minor discoloration and scuffs, while the ephemera exhibits staining, edge wear, crinkling, discoloration, and creasing from wear and age.

**Estimate: \$600 - 1,200**



**1046**  
Framed Roy Hobbs (Robert Redford) Baseball Card  
**The Natural (1984)**

A framed Roy Hobbs (Robert Redford) baseball card from Barry Levinson's sports drama *The Natural*. Sheets of vintage cards were printed out after baseball rookie Hobbs became a star player for the New York Knights. This glossy Playball-style "Roy Hobbs" card is printed in full color on cardstock with blue borders and text. It comes mounted behind glass in a custom-made laser-cut mount board featuring a movie still and the film title. The card and frame both exhibit minor edge wear. Dimensions: 14.75" x 12.75" x 1" (37 cm x 32 cm x 2 cm)

**Estimate: \$700 - 1,400**



**1045**  
Set of Hand-Drawn Barbara Black-Sterne  
Character Costume Design Illustrations  
**The Natural (1984)**

15 character costume design illustrations hand-drawn by costume artist Barbara Black-Sterne for Barry Levinson's sports drama *The Natural*. These illustrations depicting various secondary characters' costumes and a baseball glove with "The Natural Bernie Pollack" printed in two places are rendered in graphite and marker on paper. Five illustrations are backed with brown matte boards, including one labeled "The Natural Designed by Bernie Pollack Illustrated by Barbara Black-Sterne" and another labeled "Phillies 9 Boston Bees (Home)." The set exhibits grime, folds, discoloration, and adhesive loss from age. Dimensions: (each) 22" x 17" (56 cm x 43.5 cm) Sold without copyright; see notice in the Buyer's Guide.

**Estimate: \$1,500 - 3,000**



7.5" (19.25 cm)

**1047**  
Meat Hook  
**Night Of The Living Dead (1968)**

A meat hook from George A. Romero's horror film *Night of the Living Dead*. The human survivors wielded meat hooks and other weapons against the shambling dead. This J-shaped metal boning hook comes from the collection of Bill Hinzman, the first cemetery zombie seen in the film. It is welded to a hollow metal dowel grip and applied with patina and rust by production to appear aged. Also included is a Letter of Authenticity from Hinzman's widow, Bonnie Hinzman. The hook exhibits some rust flaking. Dimensions: 7.5" x 4" x 4.25" (19.25 cm x 10.25 cm x 11 cm)

**Estimate: \$1,000 - 2,000**



9.75" (25 cm)

**1048**  
Screen-Matched Christmas Town  
House Facade Model Miniature  
**The Nightmare  
Before Christmas (1993)**

A screen-matched Christmas Town house facade model miniature from Henry Selick's stop-motion fantasy musical *The Nightmare Before Christmas*. This house screen-matches to when Jack Skellington (Danny Elfman) saw the residents of Christmas Town preparing for Christmas while he sang "What's This?"

This ornately detailed house is constructed from foam core and balsa wood with a sculpted clay roof and windows used to display lights hand-painted with red, white, and green Christmas patterns. The cardboard back is taped and hand-marked "AA" by production, likely to indicate its position on the Christmas Town set. This miniature exhibits glue residue from mounted lights, a broken chimney top, missing wood, and scuffing throughout from production use. Dimensions: 3.5" x 3" x 9.75" (9 cm x 7.75 cm x 25 cm)

**Estimate: \$4,000 - 8,000**



**1049**  
Jack Skellington's (Chris Sarandon)  
Miniature Scissors and Skull Mug  
**The Nightmare  
Before Christmas (1993)**

Jack Skellington's (Chris Sarandon) miniature scissors and skull mug from Henry Selick's fantasy musical *The Nightmare Before Christmas*. Skellington removed a pair of scissors from a skull mug on his desk to cut out a paper spider snowflake. The miniature silver-color metal scissors are also seen in the foreground on page 50 of Frank Thompson's reference book "Tim Burton's Nightmare Before Christmas: The Film, the Art, the Vision." The miniature resin mug is painted silver-color, gray, and black to emulate dark hammered iron features and skull detailing with rough teeth-like features in black-and-white paint. The scissors exhibit wear at the hinge point and edges; the mug features a white bottom with black paint splatter and minor paint chipping. Dimensions: (scissors) 3.75" x 1.5" x .25" (9.5 cm x 3.75 cm x 0.75 cm); (cup) 1.75" x 1.75" x 1.5" (4.5 cm x 4.5 cm x 3.75 cm)

**Estimate: \$4,000 - 8,000**

**1050**  
Dr. Finkelstein's (William Hickey)  
Animatable Microscope and Lock's (Paul Reubens)  
Gas Can  
**The Nightmare  
Before Christmas (1993)**

Dr. Finkelstein's (William Hickey) animatable microscope and Lock's (Paul Reubens) gas can from Henry Selick's fantasy musical *The Nightmare Before Christmas*. Finkelstein's microscope was in his laboratory, while Lock's gas can was poured into a soup as they planned Santa Claus' capture. The microscope is black painted brass-color and resin with wire running up the armature. The resin gas can is painted silver-color and gray to resemble metal, with a painted-on poison skull-and-bones symbol in black paint outline and white-gray fill. The backside of the can has two drilled holes, with a drilled out hole at the spout. The lot exhibits minor paint chipping and scuffing. Dimensions: (microscope) 10" x 5.5" x 2.75" (25.5 cm x 14 cm x 7 cm); (can) 2.75" x 1.75" x 1" (7 cm x 4.5 cm x 2.5 cm)

**Estimate: \$3,000 - 6,000**



**1051**  
Screen-Matched Christmas Town Tree Model Miniature  
**The Nightmare Before Christmas (1993)**

A screen-matched Christmas Town tree model miniature from Henry Selick's stop-motion fantasy musical *The Nightmare Before Christmas*. This model screen-matches to when Jack Skellington (Danny Elfman) danced past snow-covered trees while singing "What's This?" after discovering Christmas Town. This sculpted styrofoam tree is hand-painted green, white, and blue, wrapped with a strand of silver-color tinsel wire around its base, and hand-labeled "#0" on the back. It exhibits visible glue residue on the base for mounting to set as well as on its body from the removal of bulbs and other pieces of tinsel, some loose threads of which remain. Dimensions: 9.5" x 6.5" x 11" (24.25 cm x 16.5 cm x 28 cm)

**Estimate: \$3,000 - 6,000**



**1052**  
Christmas Town House Facade Model Miniature  
**The Nightmare Before Christmas (1993)**

A Christmas Town house facade model miniature from Henry Selick's stop-motion fantasy musical *The Nightmare Before Christmas*. Jack Skellington (Danny Elfman) saw the residents of Christmas Town preparing for Christmas in their houses while he sang "What's This?" This foam core house facade is hand-painted with red, white, and green Christmas patterns on front and yellow on the reverse with multiple holes for inserting lights and at bottom for mounting to the Christmas Town set. It exhibits glue and torn fabric residue on its base and liquid streaking on front from production use. Dimensions: 3" x 3.5" x 6" (7.75 cm x 9 cm x 15.25 cm)

**Estimate: \$3,000 - 6,000**



**1053**  
Sally's (Catherine O'Hara) Whisk  
**The Nightmare Before Christmas (1993)**

Sally's (Catherine O'Hara) whisk from Henry Selick's fantasy-animation *The Nightmare Before Christmas*. Sally kept a whisk in her cooking set above her kitchenette. This black painted metal whisk is twisted and molded together to represent the quirky animation style of the film. This whisk exhibits glue residue on the handle's end and chipping paint from age. Dimensions: 8" x 1.5" x 0.5" (20.5 cm x 4 cm x 1.5 cm)

**Estimate: \$600 - 1,200**



**1054**  
Lock's (Paul Reubens) Devil Halloween Mask  
**The Nightmare Before Christmas (1993)**

Lock's (Paul Reubens) devil Halloween mask from Henry Selick's fantasy musical *The Nightmare Before Christmas*. Dressed in a red devil costume, Lock led the Oogie's Boys at Jack Skellington's (Chris Sarandon and Danny Elfman) behest to kidnap Santa Claus (Ed Ivory). This production-made resin mask is post-production painted mauve pink on front, with paint overspray on the reverse. Its teeth are painted white with darker inset discolorations between the teeth. The lot exhibits minor edge wear and paint chipping. Dimensions: 4.5" x 2" x 1" (11.5 cm x 5 cm x 2.5 cm)

**Estimate: \$800 - 1,600**



**1055**  
Set of Sally's (Catherine O'Hara) Utensils  
**The Nightmare Before Christmas (1993)**

A set of Sally's (Catherine O'Hara) utensils from Henry Selick's animation-fantasy film *The Nightmare Before Christmas*. Sally stored her utensils in her cooking set above her kitchenette. This lot consists of a black painted metal whisk twisted and molded together; a gray- and white-painted spatula with a metal shaft and handle; and a pair of gray- and white-painted three-prong tongs. This lot exhibits chipping paint, glue residue, and rust from age. Dimensions: 8" x 1.5" x 0.5" (20.5 cm x 4 cm x 1.5 cm)

**Estimate: \$800 - 1,600**



**1056**  
Allie Hamilton's (Rachel McAdams) Screen-Matched Date Costume  
**The Notebook (2004)**

Allie Hamilton (Rachel McAdams) screen-matched date costume from Nick Cassavetes' romantic drama *The Notebook*. Allie wore her costume when she met Noah's (Ryan Gosling) father after they started to date, and the upper butterfly pattern can be screen-matched from this scene. This lilac polyblend dress has a butterfly pattern on the top with a solid-color collar, and the bodice features a lace-up decorative detail on either side. Paired with Hessian wedge shoes with lilac color flowers and ribbon, these shoes feature a brown faux leather ankle strap and sisal rope accents. Also included are purple resin clip-on rose earrings. This lot exhibits some snagged threads and scuffing on the shoes.

**Estimate: \$4,000 - 8,000**



**1057**  
Production-Made Freddy Krueger (Robert Englund)  
Chest of Souls Appliance Display  
**Nightmare On Elm Street 3, A: Dream Warriors (1987)**

A display of a production-made Freddy Krueger (Robert Englund) Chest of Souls appliance from Chuck Russell's horror sequel Nightmare on Elm Street 3: Dream Warriors. Krueger revealed in the film that he kept the souls of his victims trapped inside him to give him power, and their pained faces bulged horrifically from his chest. This lot consists of a rubber chest appliance sculpted with the appearance of faces emerging from a web of burnt flesh and painted in shades of pink and orange to match Krueger's unique skin tone. The faces feature detailed acrylic eyes. The piece was made by production but ultimately unused and has been affixed to a torn-open red and green striped wool replica Freddy Krueger sweater on a black Spandex-lined mannequin torso for display. The appliance exhibits minimal paint wear from age.

**Estimate: \$2,000 - 4,000**



**1059**  
Dan's (Danny Hassel) Motorcycle Transformation Leg  
**Nightmare On Elm Street 5, A: The Dream Child (1989)**

Dan's (Danny Hassel) motorcycle transformation leg from Stephen Hopkins' gothic slasher A Nightmare on Elm Street 5: The Dream Child. While in a dream, Dan drove a motorcycle before it began to meld itself to him. This lot consists of one foam leg covered in rubber and an internal wooden armature. The leg features foam appliances and rubber tubing to appear as though it is being enmeshed with parts of a motorcycle. Production intentionally distressed this leg. This lot exhibits pitting in the rubber, fragile foam, and loose threads. Dimensions: 23.5" x 18" x 6" (59.75 cm x 45.75 cm x 15.25 cm)

**Estimate: \$1,500 - 3,000**



**1058**  
Crave Inn Menu and  
Lisa Wilcox-Autographed Promotional Still  
**Nightmare On Elm Street 4, A: The Dream Master (1988)**

Crave Inn menu and Lisa Wilcox-autographed promotional still from Renny Harlan's horror sequel A Nightmare on Elm Street 4: The Dream Master. Menus at Crave Inn were displayed on the tables diner-style. From the collection of actress Lisa Wilcox, this lot consists of one laminated menu and one promotional still. The menu features the Crave Inn design on the back and a menu on the front for "Hot Cakes," "Eggs Ranchero," "Side Orders," and "Chilled Juices and Fruits." The still features an image of an old Alice from her dream sequence and was autographed by Lisa Wilcox. This lot exhibits minor corner wear and notable adhesive residue. Dimensions: 11" x 8.5" (28 cm x 21 cm)

**Estimate: \$1,200 - 2,400**



**1060**  
Set of Three Mark Gray (Joe Seely)  
Dream Sequence Full-Body Puppets  
**Nightmare On Elm Street 5, A: The Dream Child (1989)**

Three Mark Gray (Joe Seely) dream sequence full-body puppets from Stephen Hopkins' gothic slasher film A Nightmare on Elm Street 5: The Dream Child. Freddy Krueger (Robert Englund) attacked Mark in a comic book-like dream, where he turned him into paper and cut him up. This lot consists of three full-body paper puppets. Multicolored over three different portions of the body, these puppets feature a metal sheet backing and tab at the bottom with two production-made holes. The tabs are hand-marked with "19," "55," and "62" in black ink. These puppets exhibit some discoloration, creasing, and fold lines. Dimensions: (each) 13" x 8.5" (33 cm x 21.5 cm)

**Estimate: \$1,000 - 2,000**



**1061**  
Set of Three Mark Gray (Joe Seely)  
Dream Sequence Close-Up Puppets  
**Nightmare On Elm Street 5, A: The Dream Child (1989)**

Three Mark Gray (Joe Seely) dream sequence close-up puppets from Stephen Hopkins' gothic slasher film A Nightmare on Elm Street 5: The Dream Child. Freddy Krueger (Robert Englund) attacked Mark in a comic book-like dream, where he turned him into paper and cut him up. This lot consists of three close-up paper puppet busts. Uncolored and showing Mark in the process of passing out, these puppets feature metal sheet backing and two production-made holes at the bottom. The metal sheets are hand-marked with "1," "17," and "29" in black ink. These puppets exhibit discoloration, creasing, and fold lines. Dimensions: (each) 11.25" x 7.5" (28.5 cm x 19 cm)

**Estimate: \$800 - 1,600**



**1063**  
Set of Seven Bank Bags  
**O Brother, Where Art Thou? (2000)**

Seven bank bags from the Coen Brothers' crime comedy O Brother, Where Art Thou? Ulysses Everett McGill (George Clooney), Delmar O'Donnell (Tim Nelson), and Pete (John Turturro) met George Nelson (Michael Badalucco) on the road, while he fled from police for robbing banks. The canvas cotton bank bags feature "Farmers and Merchants Bank of Meridian," "The Commercial Exchange Bank and Trust Co.," and "Member - I.J.B.C." They have serged edges and braided cotton ties. Production intentionally distressed the bags, which exhibit some print fading and some ink discoloration. Dimensions: 10" x 14" x 3" (25.5 cm x 35.5 cm x 7.75 cm)

**Estimate: \$1,000 - 2,000**



**1062**  
Cast-Autographed Bank Bag  
**O Brother, Where Art Thou? (2000)**

A cast-autographed bank bag from the Coen Brothers' crime comedy O Brother, Where Art Thou? Ulysses Everett McGill (George Clooney), Delmar O'Donnell (Tim Nelson), and Pete (John Turturro) met George Nelson (Michael Badalucco) on the road, while he fled from police for robbing banks. This canvas cotton bank bag features "Farmers and Merchants Bank of Meridian Member - I.J.B.C" in black ink and is signed by cast members, including George Clooney, Tim Blake Nelson, Del Pentecost, Quinn Gasaway, Ed Gale, J.R. Horne, Brian Reddy, Daniel von Bargen, Frank Collison, Michael Badalucco, Charles Durning, Holly Hunter, John Locke, Stephen Root, Ray McKinnon, Wayne Duvall, and John Goodman. Production intentionally distressed this bag, which exhibits print fading. Dimensions: 10" x 14" x 1" (25.5 cm x 35.5 cm x 2.75 cm)

**Estimate: \$1,500 - 3,000**



**1064**  
Pomade Pick  
**O Brother, Where Art Thou? (2000)**

A pomade pick from Joel and Ethan Coen's crime comedy O Brother, Where Art Thou? Ulysses Everett McGill (George Clooney) demanded that a convenience store employee use his vintage pick to pull down Everett's prized Dapper Dan's Pomade. This pick consists of a metallic clamp with a hand-operated lever screwed into a long wooden staff. It is intentionally distressed by production to appear aged with rust tarnishing, and faded varnish applied to the wood. The pick exhibits some nicks from use, and its clamping mechanism remains untested. Dimensions: 6" x 5" x 50" (15.25 cm x 12.75 cm x 127 cm) Contains mechanical components; see notice in the Buyer's Guide.

**Estimate: \$600 - 1,200**



**1065**  
Set of Continuity Photos  
**Ocean's Eleven (2001)**

Continuity photos from Steven Soderbergh's heist comedy Ocean's Eleven. Danny Ocean (George Clooney) violated his parole to meet his friend and partner in crime Rusty Ryan (Brad Pitt) for a heist that set the rest of the events in motion. This set consists of three binder rings with 403 behind-the-scenes photographs featuring photos of cast members in costume and makeup, locations, set pieces, and props. Their borders are hand-marked with scene numbers and other continuity information in black, blue, and red ink. They exhibit some minor staining on the borders and bending on the hole-punched corner. Dimensions: (each) 4" x 4" x 5.5" (10 cm x 10 cm x 15 cm)

**Estimate: \$1,500 - 3,000**

**1066**  
Oscar Madison's (Walter Matthau)  
Suit with Promotional Photos  
**The Odd Couple II (1998)**

Oscar Madison's (Walter Matthau) suit with promotional photos from Neil Simon's comedy sequel The Odd Couple II. Madison reunited with Felix Ungar (Jack Lemmon) after discovering that their kids were marrying. This costume includes one polyester maroon blazer jacket with button closures and flap-pockets; one cream cotton button-down dress shirt featuring chest pockets and brown square patterning; a white cotton tank top; beige poly-cotton dress trousers hand-marked "OSCAR"; a brown leather belt with brass buckle; and beige cotton socks. Two glossy black-and-white promotional photos are included. It exhibits minor holes, loose threads, and pilling; the photo has a torn, missing corner. Dimensions: (photos) 8" x 10" (20.25 cm x 25.5 cm)

**Estimate: \$600 - 1,200**

**1067**  
Underwater Clapperboard  
**Orca (1977)**

An underwater camera clapperboard from the production of Michael Anderson's thriller Orca. Sequences from the perspective of the whale hunting Captain Nolan (Richard Harris) required special underwater photography. This wooden clapperboard with a black-and-white striped clapper is labeled for underwater cinematographer J. Barry Herron, production name "Orca," and roll number "3031" in black marker on tape with additional details in the "Scene" and "Take" fields written in faded chalk. The reverse is applied with additional pieces of production-used tape. The clapperboard exhibits scuffed edges with peeling and chipped paint from production. Dimensions: 11.25" x 9.75" x 1" (28.5 cm x 25 cm x 2.5 cm)

**Estimate: \$2,000 - 4,000**

**1068**  
Vincent Griffith's  
(Yusuf Gatewood) Instruction  
Grimoire for Sacrificial Magic  
**The Originals (2013-2018)**

Vincent's instruction grimoire for Sacrificial Magic from the drama fantasy television series The Originals. In the Season 4 episode "Haunter of Ruins," Vincent Griffith (Yusuf Gatewood) explained to Marcel Gerard (Charles Michael Davis) that he created a grimoire of Sacrificial Magic without remembering doing so. This lot consists of a leather-bound book featuring a serpent embossed on the cover and two page inserts marked with a ribbon containing print and handwritten spells and diagrams for Sacrificial Magic in a foreign language. This lot exhibits notable loss of adhesion and fold creases on the one page insert. Dimensions: 8.5" x 12" x 1" (21.75 cm x 30.5 cm x 2.75 cm)

**Estimate: \$1,500 - 3,000**

**1069**  
Kaylon Costume Components  
from "Identity"  
**The Orville (2017)**

Kaylon costume components from Seth MacFarlane's sci-fi comedy-drama The Orville. Upon returning to Isaac's (Mark Jackson) home Kaylon-1 in the two-parter "Identity," Orville's crew discovered the Kaylon's mass extermination of their organic creators, and became unwilling pawns in their plan to do the same throughout the galaxy. This silver-color costume consists of a foam, vinyl and mesh collar with a zipper closure and a strip of self-fastener; a foam jumper covered in polyester and vinyl with a front zip closure and foam and resin accents; and zip-up rubber boots with foam padding and a polyester cover. The jumper is hand-marked with "Chris," "Lily" and tagged "L"; it's lined with red and black wires that convene at the back and exit through a small seam opening. The boots are hand-marked "Primary" and other illegible crossed-out markings. This costume exhibits faking vinyl and chipped paint. Contains electronics; see electronics notice in the Buyer's Guide.

**Estimate: \$2,000 - 4,000**

**1070**  
Collection of Production Design  
Artwork, Maquettes, and Paperwork  
**Out Of Africa (1985)**

Production design artwork, maquettes, and paperwork from the production of Sydney Pollack's romantic drama Out of Africa. This collection consists of five concept artworks hand-drawn and hand-painted in mixed media by production designer Stephen Grimes and labeled "Nairobi 1984 Out of Africa"; 14 faux clay African villager maquettes; a contact sheet; six production folders; 52 black-and-white production photos; 200 color-printed production image sheets; 130 pages of production paperwork; and a 144-page script dated "January 1985." The collection exhibits discoloration, grime, and stray markings throughout. Dimensions: (largest) 15.5" x 21.5" (39.5 cm x 54.75 cm) Sold without copyright; see notice in the Buyer's Guide.

**Estimate: \$2,000 - 4,000**



44.5" (113 cm)

**1071**  
 Dave Jones Collection:  
 Pyrotechnic Land Rover Model Miniature  
**Outbreak (1995)**

A pyrotechnic Land Rover model miniature from Wolfgang Petersen's medical disaster film *Outbreak*. Donald McClintock (Donald Sutherland) and William Ford (Morgan Freeman) ordered the bombing of a camp to keep a deadly virus secret. This metal pyro miniature comes from the collection of veteran model maker Dave Jones. It features a canvas top, foam wheels, a metal barrel, and acrylic windshields, all intentionally distressed by production and affixed to a wooden base. Also included are three boxes of additional loose materials, including spare wheels, body panels, roof canopies, wooden masters for shaping metal panels, and silicone molds for casting smaller parts. The model has undergone sympathetic repair and exhibits grime buildup. Some lead sheeting was used in its build, and it should therefore be handled with caution. Dimensions: 44.5" x 17" x 21" (113 cm x 43.25 cm x 53.5 cm)

**Estimate: \$1,000 - 2,000**



**1072**  
 Con-Am 27 Miner's Spacesuit Helmet  
**Outland (1981)**

A Con-Am 27 miner's spacesuit helmet from Peter Hyams' sci-fi thriller *Outland*. Con-Am 27 workers wore space suit helmets in various scenes as they mined for titanium on Jupiter's moon Io. Marshal William T. O'Neil (Sean Connery) wore a helmet during the film's climax. Created by costume designer John Mollo, this helmet consists of a vacuum-formed plastic shell with affixed non-functioning lights, a clear acrylic visor, and a cushioned PVC interior. This helmet exhibits signs of wear from production use, including paint chipping and cracking on several elements.

**Estimate: \$3,000 - 6,000**



**1073**  
 Suitcase of Kaiju Organs with Pamphlet Crew Gift  
**Pacific Rim (2013)**

A suitcase of Kaiju organs with pamphlet crew gift from Guillermo Del Toro's 2013 monster movie *Pacific Rim*. Hannibal Chau (Ron Perlman) controlled the black market on Kaiju parts and remedies. This suitcase contains six organs and one paper pamphlet. The brightly colored, textured silicone organs are encased in a silver-color, vacuum-formed pull with a clear acrylic pane. The two-fold pamphlet features a list of "Kaiju Remedies" with a small caricature, a diagram of a Kaiju body and organs, and a hyperlink to Chau's website. This lot exhibits some wear to the silicone. Dimensions: 14" x 16" x 6" (35.5 cm x 40.75 cm x 15.25 cm)

**Estimate: \$800 - 1,600**

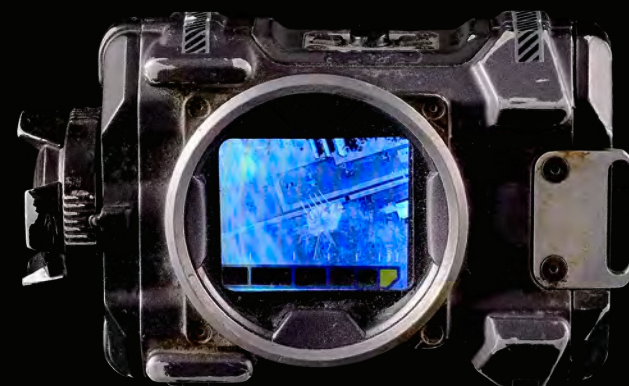

**1074**  
 Jake Pentecost's (John Boyega)  
 Screen-Matched Light-Up Tracker  
**Pacific Rim: Uprising (2018)**

Jake Pentecost's (John Boyega) screen-matched light-up tracker from Steven S. DeKnight's sci-fi sequel *Pacific Rim: Uprising*. This tracker screen-matches to the beginning of the film when Jake used it to find a disabled power core. This black plastic tracker with a metal frame, LCD screen, and a camera lens is battery powered. A side button toggles the tracker and features images of the junkyard, a moving red dot, and a distance range. "HGM 1013" is printed on a rear sticker. Production intentionally distressed this tracker to appear well-used. It exhibits chipped paint and discolored metal. Dimensions: 5.5" x 3" x 2" (14 cm x 7.75 cm x 5 cm) Contains electronics; see electronics notice in the Buyer's Guide.

**Estimate: \$2,000 - 4,000**



**1076**  
 Meg Altman's (Jodie Foster) Stunt Sledgehammer  
**Panic Room (2002)**

Meg Altman's (Jodie Foster) stunt sledgehammer from David Fincher's thriller *Panic Room*. Meg used her sledgehammer to attack Raoul (Dwight Yoakam) and caused him to fall into the stairwell. This lot consists of a stunt sledgehammer. Made of foam with a wooden handle, this sledgehammer was painted black to look resemble iron. This lot exhibits cracking, chipped wood, and discoloration. Dimensions: 35.25" x 6.5" x 3" (90 cm x 16.5 cm x 7.75 cm)

**Estimate: \$800 - 1,600**



51.5" (131 cm)

**1075**  
 Miniature Amphibious Vehicle  
**The Pacific (2010-2010)**

A miniature amphibious vehicle from Tom Hanks' and Steven Spielberg's action drama television mini-series *The Pacific*. Six men fought in the United States Marine Corp. in the brutal Pacific theater during World War II. This lot consists of a miniature fiberglass amphibious vehicle with a metal base and detailing and six plastic figurines dressed in USMC uniforms and plastic helmets. Some of the figurines have accessories attached to them, such as holsters and backpacks. This lot exhibits extensive damage to the vehicle on the top and a crack on the left side that was repaired. Dimensions: (vehicle) 51.5" x 21.5" x 13" (131 cm x 54.75 cm x 33.25 cm); (figurine) 13" x 5" x 3.5" (33.25 cm x 12.75 cm x 9 cm)

**Estimate: \$3,000 - 6,000**



**1077**  
 Satan's (Rosalinda Celentano) Burnt  
 Costume  
**The Passion Of The Christ (2004)**

Satan's (Rosalinda Celentano) burned costume from Mel Gibson's drama *The Passion of the Christ*. Satan wore dark robes as they burned from failing to tempt Jesus (Jim Caviezel) to doubt his faith. This lot consists of a black cloth and silver-color thread tunic featuring silver-color painted rubber pieces throughout to resemble burn marks and a matching design black wool hooded robe. The robe exhibits dried grass stuck to the material of the robe from production use.

**Estimate: \$1,500 - 3,000**

**1078**  
**Veil of the Temple**  
**The Passion Of**  
**The Christ (2004)**



A Veil of the Temple from Mel Gibson's drama *The Passion of the Christ*. The Veil of the Temple, which separated the High Priests from the world, tore when Jesus (Jim Caviezel) was crucified. This tapestry is sewn from black wool and cloth with layered materials of metallic and iridescent threads, embroidered designs, stiff metal plates with embossed and detailed designs, and metal rings that allow the tapestry to hang. It exhibits loose threads and materials, including round and flat metal pieces detached from the tapestry. Dimensions: 74" x 115" x 1" (188 cm x 292.25 cm x 2.75 cm) Special shipping required; see notice in the Buyer's Guide.

**Estimate:**  
**\$1,500 - 3,000**



**1079**  
**Satan's (Rosalinda**  
**Celentano) Costume**  
**The Passion Of**  
**The Christ (2004)**

Satan's (Rosalinda Celentano) costume from Mel Gibson's drama *The Passion of the Christ*. Satan wore their dark robes throughout the film as they tempted Jesus (Jim Caviezel) to doubt his faith. This lot consists of a black and red cloth ribbed tunic to resemble snake skin; a matching design black cloth and wool hooded robe with a ribbed black cloth lining to resemble snake skin; and a production tag. The robe exhibits dried grass stuck to the material of the robe from production use.

**Estimate:**  
**\$1,000 - 2,000**

**1080**  
**Porter's (Mel Gibson)**  
**Costume and Jacket**  
**Payback (1999)**



Porter's (Mel Gibson) costume from Brian Helgeland's crime-action film *Payback*. Porter wore his costume and jacket when he was run over by Pearl's (Lucy Liu) men and when Rosie (Maria Bello) patched him up afterwards. This lot consists of a gray cotton, button-down shirt; a black-and-white striped cotton button-down shirt; gray trousers (size 36); a black leather jacket with a zipper-attached interior lining; a white cotton tank undershirt (size M) with a production tag marked "Blood Stain"; black leather ankle boots (size 11 1/2); and one production tag. This lot exhibits grime, a broken interior zipper on the jacket, and discoloration on the undershirt.

**Estimate:**  
**\$2,500 - 5,000**



**1081**  
**Porter's (Mel**  
**Gibson) Costume**  
**Payback (1999)**

Porter's (Mel Gibson) costume from Brian Helgeland's crime-action film *Payback*. Porter bought a new suit after he pickpocketed another man's wallet. This lot consists of a gray wool blend two-piece suit (38 regular) marked "4B" on the jacket's interior pocket production label; a gray stripe cotton button down (16 1/2 32-33); a white tank undershirt; a black and gray motif silk-wool tie; a black leather belt (36); black leather ankle boots (11 1/2); one production tag; one costume breakdown page with handwritten notes in pencil; and three continuity photos. This lot exhibits minor scuffing to the boots.

**Estimate:**  
**\$1,500 - 3,000**



**1082**  
**Doris "Dorie" Miller's**  
**(Cuba Gooding Jr.)**  
**Screen-Matched**  
**Life Vest**  
**Pearl Harbor (2001)**

Doris "Dorie" Miller's (Cuba Gooding Jr.) screen-matched life vest from Michael Bay's historical war drama *Pearl Harbor*. Miller wore his life vest while rescuing survivors. This vintage blue cotton life vest features a lace-up front and filled neck ring. A manufacturer's yellowed tag features a faded "NOV 18 1943," an inspection mark stamped in red ink, and a removed back tie strap. The clothespin-attached manila tag reads "Pearl Harbor Costume Dept. Holds" with various hand-markings, including "CUBA GOODING JR.," "DORIE MILLER," and "CH. 3 B Sc 212." The vest exhibits water staining, discoloration, a missing collar tie, and rust spotting where a rusted clothespin was attached. \$800 - 1,600

**Estimate:**  
**\$1,000 - 2,000**



**1084**  
**Bloodied Silicone Piranha Puppet**  
**Piranha 3DD (2012)**

A bloodied silicone piranha puppet from John Gulager's horror comedy sequel *Piranha 3DD*. Flesh-eating piranhas besieged customers and staff at The Big Wet Water Park. This ornately detailed static fish puppet is constructed of silicone molded around an internal metal armature and painted blue, green, and yellow with red accents around the gills and fins, glowing yellow eyes, and sharpened white fangs. Blood stains are applied throughout by production, most visibly on the underside. It exhibits spikes on the tail and dorsal fin having snapped off from age and use, and the puppet remains fragile. Dimensions: 21" x 9" x 4" (53.5 cm x 23 cm x 10.25 cm)

**Estimate: \$2,000 - 4,000**



**1083**  
**Peter Pan's (Jeremy**  
**Sumptner) Costume**  
**Peter Pan (2003)**

Peter Pan's (Jeremy Sumpter) costume from P.J. Hogan's fantasy-adventure film *Peter Pan*. Peter Pan wore his costume throughout the film as he traveled to Never Never Land with the Darlings. Designed by Janett Patterson, this green mesh bodysuit features a sewn label marked "H 8" in black marker with green, red, and purple leaves and brown latex animal skin textured patches and a pair of matching green cloth shorts marked "Jeremy Harness Shorts" and "F Jeremy" on the interior and holes on the sides for the harness. Included is a Letter of Authenticity signed by Jeremy Sumpter and his manager. This costume exhibits fraying threads, a broken zipper, and stains.

**Estimate:**  
**\$1,500 - 3,000**



**1085**  
**John Duncan Collection:**  
**Long Deck Cannon Model Miniature**  
**Pirates Of The Caribbean:**  
**The Curse Of The Black Pearl (2003)**

A long deck cannon model miniature from Gore Verbinski's adventure film *Pirates of the Caribbean: The Curse of the Black Pearl*. Used throughout the first film, production constructed deck cannons for scenes involving the 1/6th scale shooting model of the *Black Pearl*. This cannon miniature comes from the collection of model maker John Duncan. Made of resin with a wood carriage, the model features movable wheels, resin pulleys, braided twine, and small metal screw hooks. This lot exhibits paint flaking and chipping, as well as missing pieces. Dimensions: 14.24" x 5" x 6" (36.25 cm x 12.75 cm x 15.25 cm)

**Estimate: \$1,200 - 2,400**



**1086**  
Set of Four Spanish Coins  
**Pirates Of The Caribbean:  
The Curse Of The Black Pearl (2003)**

A set of four Spanish coins from Gore Verbinski's fantasy-adventure film *Pirates of the Caribbean: The Curse of the Black Pearl*. Captain Jack Sparrow (Johnny Depp) and Elizabeth Swan (Keira Knightley) raced the hidden Spanish treasure to stop Captain Barbossa (Geoffrey Rush) from killing William Turner (Orlando Bloom) to lift his crew's curse. This lot consists of four gold- and silver-color painted pressed metal Spanish coins with crests on either side, one side reading "Philippus V D Grat" and "Hispaniarvm Rex 1701" on the other. Also included in this lot is a Letter of Authenticity signed by a crew member on production letterhead. This lot exhibits minor chipping paint around the edges. Dimensions: (largest) 1.5" x 1.5" (4 cm x 4 cm); (smallest) 1.25" x 1.25" (3.25 cm x 3.25 cm)

**Estimate: \$1,200 - 2,400**



**1087**  
Captain Hector Barbossa's (Geoffrey Rush) Earring  
**Pirates Of The Caribbean:  
The Curse Of The Black Pearl (2003)**

Captain Hector Barbossa's (Geoffrey Rush) earring from Gore Verbinski's adventure film *Pirates of the Caribbean: The Curse of the Black Pearl*. Barbossa wore his earring throughout the film. This resin earring features a textured metal hoop attached to a red-tipped dangle with brown thread. The earring is intentionally distressed by production to appear well-worn and aged. Also included is a Disney Auctions Certificate of Authenticity. The earring exhibits chips, discoloration, and frayed fibers. Dimensions: 3" x 1.5" x 0.5" (7.75 cm x 4 cm x 1.5 cm)

**Estimate: \$600 - 1,200**



27" (68.75 cm)

**1088**  
John Duncan Collection:  
Davy Jones Design  
Reference Bust  
**Pirates Of The  
Caribbean: Dead Man's  
Chest (2006)**

A Davy Jones design reference bust from Gore Verbinski's fantasy swashbuckler sequel *Pirates of the Caribbean: Dead Man's Chest*. Made by visual effects sculptor Richard Miller, this bust was used to finalize the design of Davy Jones and to be used as reference for computer graphics. This foam bust comes from the collection of model maker John Duncan. It is hand-painted gray and overlaid with textured plaster. This bust exhibits cracks throughout, most notably on the tentacles. Dimensions: 15" x 27" x 11" (38.25 cm x 68.75 cm x 28 cm)

**Estimate:  
\$2,000 - 4,000**



**1089**  
"B" Camera  
Clapperboard  
**Pirates Of The  
Caribbean: On Stranger  
Tides (2011)**

A "B" camera clapperboard from the production of Rob Marshall's swashbuckling sequel *Pirates of the Caribbean: On Stranger Tides*. This clapperboard with an acrylic slate and a striped brown wooden clapper is dated "9/10/10" and affixed with tape hand-labeled in black marker for second unit director and stunt coordinator "George Marshall Ruge," cameraman "Patrick Loungway," slate number "X221," take number "1," and camera "B-Flat." Additional tape is applied throughout the reverse. The clapperboard exhibits scratches in the acrylic, faded writing, a loose clapper, and minor paint chipping. Dimensions: 11" x 11" x 9.5" (28 cm x 2.75 cm x 24.25 cm)

**Estimate:  
\$1,200 - 2,400**



**1090**  
Light-Up DARPA Light Cannon  
**Pixels (2015)**

A light-up DARPA light cannon from Chris Columbus' comedy-fantasy film *Pixels*. DARPA soldiers and Brenner wielded light cannons as they fought against alien video games. This lot consists of a black nylon strap, a gray- and black-painted urethane cannon featuring a clear acrylic panels at the front of four barrels, two black flashlights, two gray-painted urethane handles with one featuring a red-painted start button, and artificial buttons and panels. This cannon lights up when the flashlights are powered. This lot exhibits minor scuffs and a bent back piece from production use. Dimensions: 40" x 9" x 10" (101.75 cm x 23 cm x 25.5 cm) Contains electronics; see electronics notice in the Buyer's Guide.

**Estimate: \$1,500 - 3,000**



**1091**  
DARPA Wrist Light Cannon  
**Pixels (2015)**

A DARPA wrist light cannon from Chris Columbus' comedy-fantasy film *Pixels*. DARPA soldiers and Brenner wielded light cannons as they fought against the alien video games. This lot consists of a gray and black painted urethane cannon featuring a clear acrylic etched panel at the front of the barrel with lights, chrome-color painted urethane batteries with vinyl stickers, a caution-designed vinyl sticker along the back, and two black nylon fastening straps. This lot is non-functional and exhibits scuffs along the left side, including a detaching piece from the barrel. Dimensions: 12" x 7.5" x 6" (30.5 cm x 19 cm x 15.25 cm) Contains electronics; see electronics notice in the Buyer's Guide.

**Estimate: \$1,200 - 2,400**



**1092**  
Gorilla Soldier Rifle  
**Beneath The Planet  
Of The Apes (1970)**

A gorilla soldier rifle from Ted Post's sci-fi sequel *Beneath the Planet of the Apes*. Ape soldiers carried crude brown rifles that resembled modified M1 Carbines throughout the film. This rifle features a sculpted, solid wood body painted reddish-brown with a dowel added at front and painted black to resemble a barrel, a separate midsection bolt and sight element painted black, and two metal brackets with a black nylon shoulder strap affixed are screwed into the wood. It exhibits various nicks, scuffs, and scratches throughout its finish from production use and handling. Dimensions: 35" x 6" x 2" (89 cm x 15.25 cm x 5 cm)

**Estimate: \$2,500 - 5,000**



**1093**  
Hero Gorilla Costume  
**Planet Of The Apes (1968)**

A gorilla soldier costume from Franklin J. Schaffner's sci-fi classic Planet of the Apes. Astronaut George Taylor (Charlton Heston) encountered groups of super intelligent apes after he landed on a futuristic version of Earth. This costume consists of a dark brown ribbed leather vest (size 40) with snap buttons marked "2954-1"; brown canvas trousers (size 30x31) marked "2954-3"; and a brown, black leather, and canvas shoulder sling with pouches. This lot exhibits discoloration from age.

**Estimate: \$5,000 - 10,000**



**1094**  
Chimp Mask  
**Planet Of The Apes (1968)**

A chimp mask from Franklin J. Schaffner's sci-fi classic Planet of the Apes. Astronaut George Taylor (Charlton Heston) encountered groups of super intelligent apes after he landed on a futuristic version of Earth. This chimp mask is made of black painted latex rubber with white painted teeth and black synthetic hair. The mask features a slit opening in the back for easier wear access. This lot exhibits glue residue around the chin and neck and sympathetic repair done to the synthetic hair.

**Estimate: \$2,000 - 4,000**



**1095**  
Background Gorilla  
Soldier Uniform  
**Planet Of  
The Apes (1968)**

A background gorilla soldier uniform from Franklin J. Schaffner's sci-fi classic Planet of the Apes. After landing on a futuristic version of Earth, astronaut George Taylor (Charlton Heston) encountered groups of super intelligent apes, including gorillas who served as soldiers. This costume consists of a dark brown faux leather vest with snap buttons, a purple button-up canvas long-sleeve shirt, and matching trousers. It includes a brown canvas sash with faux leather pouches, and green gloves with dark brown synthetic leather cuffs. The Western Costume tag in the vest displays the production number "2431-1," and is marked for chest "42." The inside of the vest is also hand-marked with "42." The lot exhibits scuffing in the leather and discoloration to the shirt and trousers.

**Estimate: \$2,000 - 4,000**



**1097**  
Background Orangutan Mask  
**Planet Of The Apes (1968)**

A background orangutan mask from Franklin J. Schaffner's sci-fi film Planet of the Apes. After landing on a futuristic version of Earth, George Taylor (Charlton Heston) encountered super intelligent apes, including orangutans who served as political and religious leaders. This mask is made of latex with brown-painted skin, orange hair applied throughout, and fastening strips in the rear to close it on the wearer. It exhibits some hardening to the latex and a few scuffs in the painted finish of the face.

**Estimate: \$1,000 - 2,000**



**1096**  
Zira's (Kim Hunter) Facial Appliance  
**Planet Of The Apes (1968)**

Zira's (Kim Hunter) facial appliance from Franklin J. Schaffner's sci-fi film Planet of the Apes. Doctor Zira was an animal psychologist who helped George Taylor (Charlton Heston) and Nova (Linda Harrison) escape. This lot consists of a foam latex facial appliance for the brow, nose, cheeks, and chin, painted brown with yellow teeth, with a white vacuum-formed plastic lifecast labeled "New Kim." The appliance exhibits dried and cracked edges, and has come loose from the lifecast. Dimensions: 7" x 11" x 5.5" (18 cm x 28 cm x 14 cm)

**Estimate: \$1,500 - 3,000**



**1098**  
Background Gorilla Mask  
**Planet Of The Apes (1968)**

A background gorilla mask from Franklin J. Schaffner's sci-fi film Planet of the Apes. After landing on a futuristic version of Earth, George Taylor (Charlton Heston) encountered super intelligent apes, including gorilla soldiers. This mask is made of latex with brown-painted skin, black hair applied throughout, and fastening strips in the rear to close it on the wearer. It exhibits some hardening to the latex and cracking throughout the painted finish of the face.

**Estimate: \$1,000 - 2,000**



**The John Chambers Collection:** See page 282 for an overview of John Chambers.



**1099**  
John Chambers Collection:  
Planet of the Apes Ephemera  
**Planet Of The Apes Movies (1968-1973)**

A collection of ape hair with ephemera from legendary makeup artist John Chambers for Franklin J. Schaffner's sci-fi classic Planet of the Apes. This lot contains a stack of production-made crepe wool ape hair of various colors; 37 color production stills; 113 black-and-white production stills; an orange cover-bound 45-page script and a 60-page script; two large format video film reels to promote Battle for the Planet of the Apes; one gray fabric and gold-color painted framed black-and-white behind-the-scenes photo of Chambers styling an ape; and one brown synthetic leather photo book with 46 pages of black-and-white photos. This lot exhibits edge wear, discoloration, and scuffing. Dimensions: 18" x 15" x 13" (45.75 cm x 38.25 cm x 33 cm)

**Estimate: \$1,200 - 2,400**



**1101**  
John Chambers Collection:  
Film and Television Career Photos  
**John Chambers Collection**

A collection of career-spanning ephemera from legendary makeup artist John Chambers, including content from Planet of the Apes, Cleopatra, and others. This lot contains 525 behind-the-scenes production photos over numerous productions; 102 behind-the-scenes production slides; three booklets; four binders containing 132 photos; and four framed photos from Planet of the Apes. Also included is a collection of production ephemera paperwork, such as two paper masks, a call sheet, and a contact sheet. This lot exhibits edge wear, creasing, tears, rips, discoloration, and paper fragility. Dimensions: (packaged) 57" x 36" x 10" (145 cm x 91.5 cm x 25.5 cm)

**Estimate: \$1,000 - 2,000**

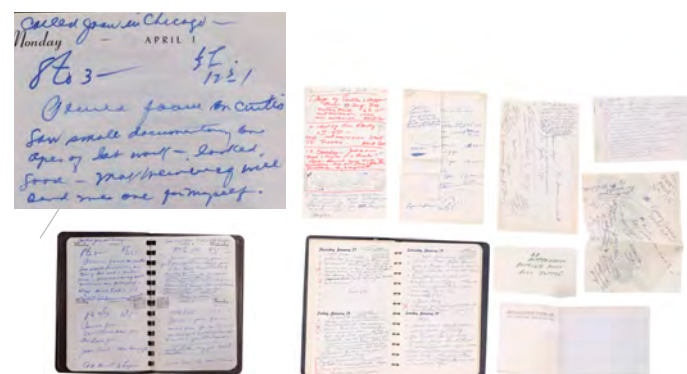

**1100**  
John Chambers Collection:  
John Chambers' Handwritten Diaries  
**Various Productions**

Legendary makeup artist John Chambers' handwritten diaries, spanning multiple productions undertaken between 1966 and 1968. Both come from the personal collection of Chambers. This lot consists of two black and brown vinyl-covered notebooks: one labeled "1966" with 97 pages of bound entries, 24 loose pages, and a napkin detailing Chambers' work creating makeup for the Star Trek franchise; and one labeled "1968" in gold-color text with 84 bound entries, including details regarding his work on the Planet of the Apes franchise. The notebooks exhibit discoloration and ink smears. Dimensions: (each) 5.5" x 8.25" x 0.5" (14 cm x 21 cm x 1.5 cm)

**Estimate: \$2,000 - 4,000**



**1102**  
John Chambers Collection: Emmy, Oscar, and Awards  
Documentation and Ephemera  
**John Chambers Collection**

A collection of Emmy®, Oscar®, and Academy Awards® ephemera and documentation from legendary makeup artist John Chambers. This lot contains one brown scrapbook with 21-pages featuring Oscar® congratulation notes and cards; two Emmy® honors; three Emmy programs; one Academy membership invitation packet; two "Member-at-Large" letters from Gregory Peck; one letter from Don Post Studios; one Island of Dr. Moreau honors folder; and one 1967 Academy Awards® illustrated book with "Victor Beaumont" stamped on the sides. Included is a variety of correspondence, photography, and miscellaneous ephemera enclosed in envelopes relating to the awards Chambers received. The lot exhibits edge wear, discoloration, creasing, and scuffing. Dimensions: 19" x 17" x 6" (48.25 cm x 43.25 cm x 6 cm)

**Estimate: \$1,200 - 2,400**



**1103**  
John Chambers Collection:  
The Island of Dr. Moreau Collection  
**John Chambers Collection**

John Chambers' makeup appliances and ephemera from Don Taylor's sci-fi horror The Island of Dr. Moreau. Chambers oversaw makeup effects for Moreau's animal-human creatures. This lot consists of an orange foam latex mask, unpainted resin horn castings, rubber latex gloves with hair; an unpainted foam latex appliance for Michael York's conversion; two dental appliances; brown foam latex ear pieces; blonde hair appliances in a tin container; a foam finger casting; two Virgin Islander magazine issues; and seven behind-the-scenes photos. The lot exhibits chipped paint, latex cracking and crinkling, and missing nails from gloves. Dimensions: (overall) 12" x 12" x 14" (30.5 cm x 30.5 cm x 35.5 cm)

**Estimate: \$1,000 - 2,000**



**1105**  
John Chambers Collection:  
John Chambers Face and Hand Casts  
**John Chambers Collection**

Face and hand casts of legendary makeup artist John Chambers. Chambers received an Honorary Academy Award® for his groundbreaking prosthetics work in classic films like Planet of the Apes and television series such as Star Trek. These rare, original plaster casts of Chambers' face and hands come from his own collection. The face cast is molded around a wooden handle wrapped with tape and rope, while the right hand cast's base is engraved "Chambers '55." Also included is a color-printed photograph of the casts. The casts exhibit some scuffing and adhesive residue. Dimensions: (largest) 17" x 12" x 5" (43.25 cm x 30.5 cm x 12.75 cm)

**Estimate: \$600 - 1,200**



**1104**  
John Chambers Collection: Kirk Douglas Face Cast  
**The List Of Adrian Messenger (1963)**

A Kirk Douglas face cast from the production of John Huston's mystery film The List of Adrian Messenger. George Brougham (Kirk Douglas) wore realistic masks to hide his identity as he committed his crimes. This yellow plaster face cast comes from the collection of legendary makeup artist John Chambers, who created it to design the make-up of Douglas' character's masks. It exhibits scuffing and minimal chipping from age. Dimensions: 9" x 6" x 4" (23 cm x 15.25 cm x 10.25 cm)

**Estimate: \$800 - 1,600**



**1106**  
John Chambers Collection: Set of Edgar Bergen and  
Charlie McCarthy Hand Casts, Molds, and Photos  
**John Chambers Collection**

Hand casts, molds, and photographs of ventriloquist Edgar Bergen and his signature dummy Charlie McCarthy. This set comes from the collection of legendary makeup artist John Chambers, who sculpted hand molds for Bergen's elaborate vaudevillian dummies before working extensively in classic film and television. It consists of two rare, original plaster hand casts; four plaster hand molds applied with red tape; and four color-printed photos of Bergen, McCarthy, and the casts dated "11/7/55." Holes are punched in the centers of one cast and two molds, and each mold exhibits adhesive residue. Dimensions: (largest) 7" x 7" x 5" (18 cm x 18 cm x 12.75 cm)

**Estimate: \$400 - 800**



**1107**  
John Chambers Collection:  
Personalized Framed Illustration Collection  
**John Chambers Collection**

Framed illustrations from makeup artist John Chambers. This framed lot consists of Dick Tracy artwork with a note signed by Chester Gould; a 1973 MAD magazine cover and letter signed by associate editor Jerry De Fuccio; 1962 Interlandi artwork for the Below Olympus comic with a hand-marked note and artwork photograph; Gahan Wilson artwork; uncredited artwork with apes working on Chambers in a makeup chair; a 1964 Moon Mullins comic strip and handwritten note from Ferd Johnson; and an admirer's drawing and message. The lot exhibits minor scratches, paint chipping, and scuffing. Dimensions: 24" x 16" x 6" (61 cm x 40.75 cm x 15.25 cm) Sold without copyright; see copyright notice in the Buyer's Guide.

**Estimate: \$1,000 - 2,000**



**1109**  
John Chambers Collection:  
Collection of John Chambers' Military Memorabilia  
**John Chambers Collection**

John Chambers' military memorabilia from the 1930's onward. Chambers documented his life with scrapbooks and other ephemera. This lot consists of one red 40-page binder with 17 loose photos of Chambers' prosthetic work with Disabled Veterans; four paper- and/or leather-bound scrapbooks of varying page counts; 118 personal letters; 29 postcards; 64 unmailed postcards; 55 pieces of received mail; 16 travel brochures; six books; miscellaneous paper items; one framed black and white photo; and one framed Army of the United States certificate. The scrapbooks feature collections of military insignias and badges, as well as photographs from World War II, maps and paper clippings. This lot exhibits extreme paper fragility, grime buildup, rips, tears, and residue. Dimensions: 24" x 19" x 12" (61 cm x 48.35 cm x 30.5 cm)

**Estimate: \$1,500 - 3,000**



**1108**  
John Chambers Collection: Faux Hair with Styling Tools  
**John Chambers Collection**

Faux hair with styling tools from the collection of legendary makeup artist John Chambers. This set consists of a gray and black hairpiece; a chrome-color plaster and foam bald cap with elongated sides and back mounted on a metal pole and screwed into a plywood base; a metal puncturing tool; a telescoping cylindrical curling tool; a heated styling tool with four insulated rods; two bundles of yarn; and 13 faux hair bundles of varying colors. The hair exhibits frayed edges and loose strands, while the tools and forms exhibit discoloration, scratching, scuffing, and nicks. Dimensions: (packaged) 45" x 20" x 16" (114.5 cm x 50.75 cm x 40.75 cm)

**Estimate: \$600 - 1,200**



**1110**  
John Chambers Collection:  
Chambers Family Photo Portfolios  
**John Chambers Collection**

Family photos and ephemera from the legendary makeup artist John Chambers. This lot comes from the personal collection of John Chambers. It consists of eight photo albums, with seven albums each placed within brown and gold-color textured protective boxes, replete with Polaroid color pictures and handwritten annotations; 265 Ektachrome transparency slides featuring handwritten annotations; a blue and black paper origami star; 25 loose photos; and multiple personal handwritten and typed correspondences circa 1930 to 1969. Ephemera exhibits edge wear, creasing, color fade, tears, rips and staining from use, age, and conveyance. Dimensions: (largest photo album) 16" x 10.5" x 16" (51 cm x 40.75 cm x 40.75 cm)

**Estimate: \$800 - 1,600**



**1111**  
Jack Barron-Signed Final Shooting  
Script with Call Sheet  
**Conquest Of The Planet Of The Apes (1972)**

A final shooting script from the production of J. Lee Thompson's sci-fi sequel Conquest of the Planet of the Apes. The film, written by Paul Dehn, was the fourth in the franchise. This lot consists of a black three-ring binder containing a 99-page final shooting draft script dated "January 18, 1972" with an orange cover page signed by makeup artist Jack Barron. Also included is a call sheet for "2/10/72." The script exhibits edge wear, corner creasing, torn hole punches in the last page, and staining from use and age. Dimensions: 10" x 11.5" x 1.5" (25.5 cm x 29.25 cm x 4 cm)

**Estimate: \$700 - 1,400**



**1113**  
Man Hunt Ape (Chad  
Bannon) Make-Up  
Test Head  
**Planet Of  
The Apes (2001)**

A Man Hunt Ape (Chad Bannon) makeup test head from Tim Burton's action-sci-fi film Planet of the Apes. Man Hunt Ape tracked down Leo Davidson (Mark Wahlberg) and other humans he freed as they escaped ape custody. This lot consists of four bundles of dark-brown synthetic hair; a black-painted foam bust with carved eyes and teeth labeled "CHAD B" and "CHAD BANNON HAIR COWL"; a dark-brown synthetic hair cowl with snap buttons and foam padding; and a black-painted latex foam face covering adhered to the bust. It exhibits grime and label adhesion loss. Dimensions: 25" x 13.5" x 22" (63.5 cm x 34.5 cm x 56 cm)

**Estimate:  
\$1,000 - 2,000**

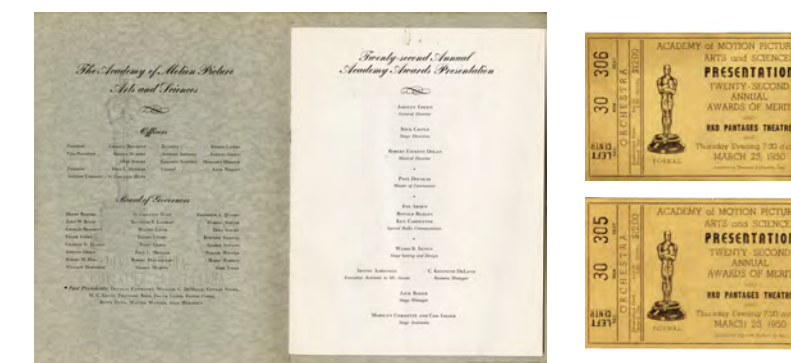

**1112**  
22nd Annual Academy Awards®  
Program with Two Tickets  
**Academy Awards**

A program and two tickets from the 22nd Annual Academy Awards®. The ceremony took place at the RKO Pantages Theatre on March 23, 1950. This lot consists of one gray paper program with gold-color inlays of the event title, location, date and an image of an Oscar® statuette on the cover and additional information printed inside, and two gold-color paper tickets with the event's information, an image of an Oscar® statuette, and seating assignments. The program exhibits some discoloration from age and corner creasing, and the tickets exhibit some edge wear. Dimensions: 9.25" x 12" x 0.25" (23.25 cm x 30.5 cm x 0.75 cm)

**Estimate: \$500 - 1,000**



**1114**  
Betty Parker's (Joan  
Allen) Costume  
**Pleasantville (1998)**

Betty Parker's (Joan Allen) costume from Gary Ross's fantasy comedy-drama Pleasantville. Betty wore her dress at David (Tobey Maguire) and Bill's (Jeff Daniels) trial. This costume consists of a yellow rayon button-up V-neck jacket with a gray and yellow polka-dot hem; a sleeveless yellow rayon sheath dress also hemmed with gray and yellow polka-dot trim; a yellow belt; and three production tags. The dress features an interior tag reading "Ms. Joan Allen." The production tags are hand-marked "55," "53," "Betty," and "Joan Allen" for scenes "197-200" change "7" along with additional notes. This costume exhibits snagged threads and discoloration at the hem.

**Estimate: \$600 - 1,200**



**1115**  
Two "Believe" Tickets  
**The Polar Express (2004)**

Two train tickets from Robert Zemeckis' animated adventure film *The Polar Express*. Tickets were carried by children who traveled aboard the *Polar Express*, and had to be punched by the Conductor (Tom Hanks). Physical props were created for the film and used by motion-captured, live-performing actors. The actors and props were then overlaid with computer-generated 3D models. The lot comprises one large ticket and one smaller ticket, both made of card paper and numbered "0001225". The tickets display an image of the train on one side, and the words "Round Trip" on the other. The word "Believe" - which featured on the Hero Boy's (also Hanks) ticket - is printed on both sides, as if it has been punched into the ticket. Dimensions (largest): 2.75" x 7.5" x 0.25" (7 cm x 19 cm x 0.75 cm)

**Estimate: \$6,000 - 12,000**



**1117**  
Large Stand-In Punch  
Puppet Display  
**The Polar  
Express (2004)**

A displayed stand-in punch puppet from Robert Zemeckis' animated adventure film *The Polar Express*. Hero Boy (Tom Hanks) played with a punch puppet on Christmas morning when his younger sister Sarah handed him a present containing his lost bell from Santa. Physical props were used by live-performing actors, who dressed in Lycra suits covered in sensors for the purposes of motion capture. The actors and the props they held were then overlaid with computer-generated 3D models. This puppet features a resin head, painted wooden hands and legs, and is dressed in a deep red velvet costume decorated with gold-color trim. It comes with a custom-made display featuring the film title. Dimensions (displayed): 12" x 11.75" x 28.25" (30.5 cm x 30 cm x 72 cm)

**Estimate:  
\$2,000 - 4,000**



**1116**  
Train Engineer (Michael Jeter) Striped Cap  
**The Polar Express (2004)**

A train engineer (Michael Jeter) striped cap from Robert Zemeckis' animated adventure film *The Polar Express*. Smokey and Steamer, the fireman and engineer of the *Polar Express* (both played by Jeter) wore striped hats as they worked tirelessly to prevent the train from crashing. Physical props and costume components were used by live-performing actors, who dressed in Lycra suits covered in sensors for the purposes of motion capture. The actors and the props they held were then overlaid with computer-generated 3D models. The blue-and-white striped peaked cap features a round embroidered patch at the front with the letters "PE" attached. The hat has been intentionally distressed with dirt stains and marks.

**Estimate: \$2,000 - 4,000**



**1118**  
Baby Swee'pea's (Wesley  
Ivan Hurt) Costume  
**Popeye (1980)**

Baby Swee'pea's (Wesley Ivan Hurt) costume from Robert Altman's musical comedy *Popeye*. Baby Swee'pea wore his costume as he was abducted by Bluto (Paul Smith) to bait his surrogate parents, Popeye (Robin Williams) and Olive Oyl (Shelley Duvall). This costume includes a red woolen infant-size onesie jumpsuit with frilly sleeves and a white and blue collared opening for the neck. The onesie is labeled "Swee'pea" on the interior and features a second white and blue collar attached over the original with fastening snaps. The costume exhibits signs of wear, including discoloration on the collar and other small stains throughout.

**Estimate:  
\$2,000 - 4,000**



**1119**  
Hand-Painted Michael Pangrazio  
Moon over Night Landscape Matte Painting  
**Prancer (1989)**

A hand-painted Michael Pangrazio moon over night landscape matte painting from John D. Hancock's fantasy drama film *Prancer*. Jessica Riggs (Rebecca Harrell) chased Prancer (Boo) through the woods to the cliff overlooking the town. This lot consists of one oversize matte painting on a framed glass panel. It features a hand-painted image of a forested area at night with a full moon in the sky and an illuminated town in the background. It also features a hand-marked "MP-1" on the upper right corner. This lot exhibits scratches and lifted tape. Dimensions: 49.5" x 61" x 1" (125.75 cm x 155 cm x 2.5 cm) Special shipping required; see notice in the Buyer's Guide. Sold without copyright; see notice in the Buyer's Guide.

**Estimate: \$1,500 - 3,000**



**1121**  
Dutch's (Arnold Schwarzenegger) 40mm Grenade  
**Predator (1987)**

Dutch's (Arnold Schwarzenegger) 40mm grenade from John McTiernan's sci-fi action film *Predator*. Dutch took apart his two remaining 40mm grenades to salvage the gunpowder while building traps for the *Predator*. Split in two pieces by production, this metal 40mm grenade features a gold-color projectile with a flattened end and an intact primer on its green casing. The round exhibits mild denting, scuffed and chipped paint, scratches in the finish, and discoloration. Dimensions: 2" x 2" x 4" (5 cm x 5 cm x 10 cm)

**Estimate: \$2,000 - 4,000**



**1120**  
Hand-Painted Michael Pangrazio  
Neighborhood in Snow Matte Painting  
**Prancer (1989)**

A hand-painted Michael Pangrazio neighborhood in snow matte painting from John D. Hancock's fantasy drama film *Prancer*. Jessica Riggs (Rebecca Harrell) and Carol Wetherby (Ariana Richards) walked on the snowy hill and talked as they pulled their sled. This lot consists of one oversize matte painting on a framed glass panel. It features a hand-painted image of a snow-covered town with a matte-black area over the lower half of the painting. The back features production-applied tape and paper with light blue and beige paint. This lot exhibits scratches and lifted tape. Dimensions: 49.5" x 61" x 1" (125.75 cm x 155 cm x 2.5 cm) Special shipping required; see notice in the Buyer's Guide. Sold without copyright; see copyright notice in the Buyer's Guide.

**Estimate: \$1,500 - 3,000**



**1122**  
Hand-Drawn Predator Concept Art  
**Predator 2 (1990)**

A piece of hand-drawn concept art of the *Predator* from Stephen Hopkins' sci-fi action sequel *Predator 2*. The *Predator* (Kevin Peter Hall) hunted the citizens of Los Angeles, with only Lieutenant Mike Harrigan (Danny Glover) to stop him. Rendered in pencil on drawing paper, this hand-drawn artwork of the Yautja hunter's front and side profiles is annotated "top knot". It has been stored rolled and exhibits some signs of wear from use and age, including pin holes, creasing, tape remnants on the back, and a rip in the top left corner. Dimensions: 24" x 19" (61 cm x 48 cm) Sold without copyright; see notice in the Buyer's Guide

**Estimate: \$2,500 - 5,000**



**1123**  
Set of Three Ampules Δ  
**Prometheus (2012)**

Three ampules from Ridley Scott's sci-fi prequel Prometheus. Extraterrestrial engineers stored terraforming biochemicals in ampules which the Prometheus crew found in cavernous chambers. Taking inspiration from delicate Roman glass, Raku pottery specialist Rob Sollis crafted three different sizes of urn for the chamber sequence, with each size represented in this set. Each consists of a lid and base constructed from hard biscuit foam dressed with resin skin, painted copper-color, and etched vertically with alien text along curved bodies. The ampules exhibit streaking and scratching throughout with chipping to the paint finish on the smallest urn. Dimensions: (largest) 31" x 11" x 11" (79 cm x 28 cm x 28 cm)

**Estimate: \$3,000 - 6,000**

**1124**  
Dr. Elizabeth Shaw's  
(Noomi Rapace) Stunt Ax  
**Prometheus (2012)**

Dr. Elizabeth Shaw's (Noomi Rapace) stunt ax from Ridley Scott's sci-fi prequel Prometheus. Shaw wielded an ax as she boarded the crashed lifeboat and discovered her alien progeny had grown to massive size. Shaw was seen battling the xenomorph with her ax in a deleted scene in the film. The lot features a stunt ax with an inner metal armature. Made of rubber foam, this ax features a curved handle and a sawtooth edge on the ax head's beard, as well as a spiked throat and knob. Production intentionally distressed this ax. This lot exhibits discoloration, notable adhesive residue, cracks in the rubber, and pitting. Dimensions: 36" x 11.5" x 2" (93 cm x 30 cm x 7 cm)

**Estimate: \$2,000 - 4,000**

30" (76.25 cm)



**1125**  
Large Ampule  
**Prometheus (2012)**

A large ampule from Ridley Scott's sci-fi prequel Prometheus. Extraterrestrial engineers stored terraforming biochemicals in ampules which the Prometheus crew found in cavernous chambers. Taking inspiration from delicate Roman glass, Raku pottery specialist Rob Sollis crafted three different sizes of alien urn for the chamber sequence, with this piece representing the largest size. This particular version is constructed from hard biscuit foam dressed with a resin skin, painted a shiny copper-color, and etched vertically with alien text along its gently curved body. It exhibits streaking, black smudging, scratching, and minor scuffs from production use and handling. Dimensions: 9" x 7" x 30" (23 cm x 18 cm x 76.25 cm)

**Estimate: \$1,500 - 3,000**



**1126**  
Big Kahuna Burger Paper Bag  
and Burger Wrapper  
**Pulp Fiction (1994)**

A Big Kahuna Burger paper bag and burger wrapper from Quentin Tarantino's crime film Pulp Fiction. Big Kahuna Burger products appeared in the scene where Jules Winnfield (Samuel L. Jackson) and Vincent Vega (John Travolta) visited Brett (Frank Whaley) at his apartment to collect a briefcase for their boss Marsellus Wallace (Ving Rhames). This lot consists of one white paper bag and one yellow paper wrapper from the collection of on-set dresser McPherson O. Downs. Both feature the colorful Big Kahuna Burger logo. The bag also features a black logo reading "Stone 12" and is printed on one side towards the top, with a recycling logo and serial number printed on the bottom. The wrapper is single-sided. This lot exhibits creasing, discoloration, and small tears from age and usage. Dimensions: 7" x 14" (18 cm x 35.5 cm)

**Estimate: \$2,000 - 4,000**



**1127**  
Brett's (Frank Whaley)  
Apartment Wall Sconce  
**Pulp Fiction (1994)**

Brett's (Frank Whaley) apartment wall sconce from Quentin Tarantino's crime film Pulp Fiction. When Hitmen Vincent Vega (John Travolta) and Jules Winnfield (Samuel L. Jackson) visited Brett to recover Marcellus Wallace's (Ving Rhames) briefcase, a sconce was seen next to the bedroom door. This metal sconce comes from the collection of the film's on-set dresser McPherson O. Downs. It is painted black and features a push button toggle switch with an orange glass filament bulb. The rear features a wire secured by black gaffer's tape. It exhibits paint chipping and edge wear exposing metal, and its functionality remains untested. Dimensions: 15" x 5.5" x 4.5" (38 cm x 14 cm x 11.5 cm) Contains electronics; see electronics notice in the Buyer's Guide.

**Estimate: \$1,000 - 2,000**

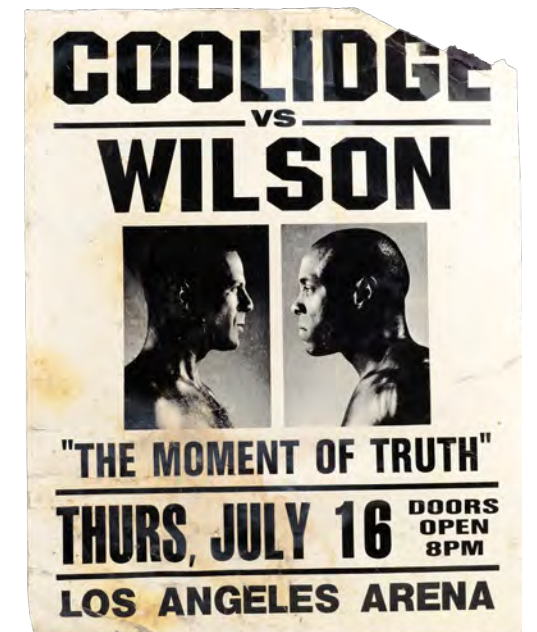

**1128**  
Butch Coolidge (Bruce Willis)  
Fight Poster Prototype  
**Pulp Fiction (1994)**

A Butch Coolidge (Bruce Willis) fight poster prototype from the production of Quentin Tarantino's crime drama Pulp Fiction. Marsellus Wallace (Ving Rhames) displayed a poster for the fight he paid Coolidge to throw against rival Floyd Wilson (Carl Allen), but Butch instead won the fight by killing Wilson. This production-made, black-and-white prototype headlined "Coolidge vs Wilson" with pictures of the boxers and information about their fight's date and location comes from the collection of the film's on-set dresser McPherson O. Downs. It exhibits significant signs of production use, including tape residue, grime, staining on both sides, and a torn top right corner. Dimensions: 22" x 28" (56 cm x 71.25 cm)

**Estimate: \$600 - 1,200**



**1129**  
Zombie Andre Toulon (Udo Kier) Costume  $\Delta$   
**Puppet Master: The Littlest Reich (2018)**

A zombie Andre Toulon (Udo Kier) costume from Sonny Laguna's and Tommy Wiklund's horror comedy Puppet Master: The Littlest Reich. After Toulon was reanimated as a zombie, he attacked Ashley (Jenny Pellicer) then disappeared into the wilderness. This costume consists of one head, one bodysuit, a pair of hands, and a pair of feet. Composed of foam latex, this costume features a desiccated zombie sculpt with sculpted roots and mushrooms, as well as added plastic twigs, faux stones, and moss. The bodysuit features a mesh interior and back zip. Painted in shades of earthy tones, the head features purple highlights. This costume exhibits rips and tears, as well as missing and loose components.

**Estimate: \$4,000 - 8,000**

**1130**  
Leonard Smalls' (Randall "Tex" Cobb) Chain Weapon  
**Raising Arizona (1987)**

Leonard Smalls' (Randall "Tex" Cobb) Chain Weapon from Joel and Ethan Coen's crime comedy Raising Arizona. The biker Smalls fought H.I. "Hi" McDunnough (Nicolas Cage) with his chain weapon as he tried to forcefully take back Nathan Jr. for money. This lot consists of one black plastic chain with two black-painted foam rubber "weights." The weights feature small rings on their ends to allow for attachment to the chain. This lot exhibits worn, flaked, and peeled paint from production and age. Dimensions: 10.25" x 5.25" x 5.25" (26 cm x 13.5 cm x 13.5 cm)

**Estimate: \$600 - 1,200**



**1131**  
Gil Hibben-Signed Prototype John Rambo (Sylvester Stallone) Knife  
**Rambo III (1988)**

A prototype of John Rambo's (Sylvester Stallone) knife from Peter MacDonald's action sequel Rambo III signed by knifemaker and designer Gil Hibben. After his mentor Col. Trautman (Richard Crenna) was captured by Soviet forces in Afghanistan, Rambo wielded his knife on a mission to free him at any cost. Hibben created a custom bowie knife for the film, with this hand-carved wooden prototype originating from Stallone's personal collection. It is dated "1-17-87," marked "Rambo III," and signed in ink by Hibben along with annotations regarding the final weapon's design. Also included is a padded black leatherette knife case labeled "Rambo III Hibben Knives" in gold print. The wood exhibits discoloration and flaking to its varnish, and the case is punctured along its edges. Dimensions: 17" x 4" x 1" (43.25 cm x 10.25 cm x 2.5 cm)

**Estimate: \$3,000 - 6,000**



**1132**  
Hand-Drawn Bob Mackie Raquel Welch Costume Design Sketch  
**Raquel (1970)**

A sketch for a costume design for Raquel Welch hand-drawn by costume designer Bob Mackie for Welch's 1970 television special Raquel. Welch donned a variety of Mackie's elaborate gowns and costumes throughout the special as she danced, sang, and performed sketches with fellow celebrities. This sketch of Welch in polka-dotted boot-leg jumpsuit is labeled "Raquel," numbered "1251-2," and signed by Mackie in mixed media on Crescent illustration board. The board is stapled in its top corners and exhibits liquid streaking and putty residue from production. Dimensions: 14" x 19" (35.75 cm x 48.25 cm) Sold without copyright; see notice in the Buyer's Guide.

**Estimate: \$300 - 600**



**1133**  
Ivan Danko's (Arnold Schwarzenegger) Costume  
**Red Heat (1988)**

Ivan Danko's costume from Walter Hill's action adventure Red Heat. Danko wore his Moscow Militsiya uniform while on an operation against Georgian drug kingpin Viktor Rostavili (Ed O'Ross). This costume consists of a charcoal-gray faux fur ushanka with a band and a hammer and sickle pin; a black silk tie; a charcoal-gray wool trench coat with red insignias on the collar and metal buttons; a charcoal-gray rayon blazer with medals and metal buttons; a beige cotton long-sleeve button-up shirt; an off-white cotton-blend cable-knit cap-sleeve thermal shirt; charcoal-gray trousers with six buttons on the interior; and black lace up loafers (size 12) with rubber soles. Included are four production tags, hand marked for "Arnold," "Scene 61A - 61B," "Change 1A," "Too Small Emergency Only," and "Needs to be Cleaned." This costume exhibits discoloration, fabric holes, and dented buttons.

**Estimate: \$2,000 - 4,000**



**1134**  
Denton Van Zan's (Matthew McConaughey) Stunt Shotgun  
**Reign Of Fire (2002)**

Denton Van Zan's (Matthew McConaughey) stunt shotgun from Rob Bowman's post-apocalyptic fantasy Reign of Fire. Van Zan carried his signature shotgun throughout his dragonslaying campaign across the British Isles. This stunt fiberglass Mossberg 500 Cruiser shorty is painted brown and black to appear metallic and modified with a Tacstar foregrip and a vertical grip. Also included is a matching leatherette holster with a green nylon clip-on shoulder strap. The lot exhibits scuffed and scratched paintwork and some cracks in the fiberglass from production use. Dimensions: 22.5" x 2" x 7" (57 cm x 5 cm x 17 cm) Restricted ownership; see replica firearm notice in the Buyer's Guide.

**Estimate: \$1,500 - 3,000**



**1135**  
Dr. Alexander Isaacs' Tyrant Costume Display  
**Resident Evil: Extinction (2007)**

Dr. Alexander Isaacs' Tyrant costume from Russell Mulcahy's action horror sequel Resident Evil: Extinction. The zombie-bitten Isaacs (Iain Glen) turned himself into the monstrous Tyrant by overdosing on antivirus. This costume consists of a foam latex and elastic cowl with a snap-button closure; a matching zip-up muscle suit with hook-and-eye closure, snap buttons on the collar and hem, and waist stirrups hand-marked "Hero"; an oversize stunt right Tyrant hand molded around a fiberglass puppeteering glove inset with plastic tips for structure and marked "stunt"; an SFX glove with resin claws painted blue; and green cotton trousers internally hand-marked "Dr. Isaacs." The lot has undergone sympathetic repair and is presented on a gray fiberglass mannequin with a glass display base. It exhibits mold, rust, interior staining, and foam fragility. Dimensions: 76" x 28.5" x 28" (193 cm x 72.5 cm x 71.25 cm) Special shipping required; see notice in the Buyer's Guide.

**Estimate: \$3,000 - 6,000**



**1136**  
Jane Russell-Autographed Hand-Painted Travilla Costume Design Artwork  
**The Revolt Of Mamie Stover (1956)**

Costume design artwork hand-painted by costume designer William Travilla, aka Travilla, for Raoul Walsh's classic drama The Revolt of Mamie Stover and autographed by Jane Russell. Former prostitute Mamie Stover (Russell) donned her iconic blue dress to perform as "Flaming Mamie" and in promotional material for the film. This artwork depicting Mamie's blue dress is painted in mixed media, labeled "Jane Russell in 'The Revolt of Mamie Stover,'" signed by Travilla, and autographed "To Bob - God Bless!" by Russell on board. The board exhibits cord holes, a liquid stain, and residue along its edges. Dimensions: 15" x 20" (38.25 cm x 51 cm) Sold without copyright; see notice in the Buyer's Guide.

**Estimate: \$300 - 600**



**1137**  
Robin Hood's (Kevin Costner) Production-Made Hood  
**Robin Hood: Prince Of Thieves (1991)**

Robin Hood's (Kevin Costner) production-made hood from Kevin Reynolds' action-adventure Robin Hood: Prince of Thieves. Robin wore his hood throughout the film as he and his fellow outlaws fought the corrupt and villainous Sheriff of Nottingham (Alan Rickman). This hood was custom-made by the costume house "Angels" and includes its namesake label sewn into the interior. It is made of textured mauve cotton embellished with metal studs, red velvet applique and gold-color trimmings. This decorative design differs slightly from the screen-used hood, indicating that this was most likely a production-made backup. It exhibits minor areas of rust and oxidation on and around the metal studs.

**Estimate: \$2,500 - 5,000**



**1138**  
Robin Hood's (Kevin Costner) Arrow  
**Robin Hood: Prince Of Thieves (1991)**

Robin Hood's (Kevin Costner) arrow from Kevin Reynolds' action-adventure Robin Hood: Prince of Thieves. Robin fired his signature arrows throughout the film as he and his fellow outlaws fought the corrupt and villainous Sheriff of Nottingham (Alan Rickman). The wooden arrow features white fletching and a resin nock painted in the same color as the wooden shaft. It exhibits a missing arrow tip, and one side of the nock has broken off from production use. Dimensions: 28.25" x 1.25" x 1.25" (71.5 cm x 3 cm x 3 cm)

**Estimate: \$1,000 - 2,000**



**1139**  
Azeem's (Morgan Freeman) Tunic  
**Robin Hood: Prince Of Thieves (1991)**

Azeem's (Morgan Freeman) tunic from Kevin Reynolds' action-adventure Robin Hood: Prince of Thieves. Azeem wore his tunic under his blue cloak throughout the film, and maintained his oath of accompanying Robin Loxely (Kevin Costner) and one day saving his life in return for freeing him from the Moorish prison. The tunic is made from a brown oilcloth with a cotton lining and blue woven trimmings on the sleeves. It is missing the matching blue woven neck detailing seen on screen. An Angels label is sewn to the interior featuring the name "Azlam" [sic] handwritten in black pen. The piece has been intentionally distressed to look aged and worn, and also exhibits gold-color paint marks and stage blood stains from production use.

**Estimate: \$1,500 - 3,000**



**1140**  
Sheriff of Nottingham's (Alan Rickman) Cape  
**Robin Hood: Prince Of Thieves (1991)**

Sheriff of Nottingham's (Alan Rickman) cape from Kevin Reynolds' action-adventure Robin Hood: Prince of Thieves. The Sheriff wore his dark cape throughout the original theatrical version as he attempted to capture Robin Hood (Kevin Costner) and his band of outlaws and continue to corruptly rule the land. However, this cloak does not appear in subsequent cuts. The cloak is made of patchworked black leather and features two studded straps that are worn across the chest and fastened at the back. Custom-made for production by the costumier house Angels, it includes an inventory tag that reads "Alan Rickman, Robin Hood Prince of, Black Leather Cape."

**Estimate: \$1,500 - 3,000**

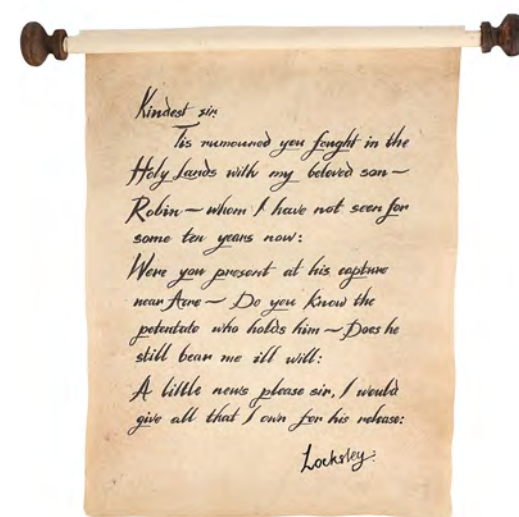

**1141**  
Mortianna's (Geraldine McEwan)  
Dagger and Sheath  
**Robin Hood:**  
**Prince Of Thieves (1991)**

Mortianna's (Geraldine McEwan) dagger and sheath from Kevin Reynolds' action-adventure Robin Hood: Prince of Thieves. Mortiana, the gruesome mother of the Sheriff of Nottingham (Alan Rickman), used her dagger to feed meat to her pet crow.

This dagger, believed to be the only one made for production, originated with a crew member. It features a slim steel blade with metal twisting snakes forming the cross-guard, a black-painted, ridged resin grip, and a resin skull pommel. Accompanying it is a minimalistic aluminum sheath with a cut-out midsection. The pommel exhibits significant paint wear from production use. Dimensions: 17.75" x 4.50" x 1.50" (45 cm x 11.5 cm x 4 cm)

**Estimate: \$1,500 - 3,000**

**1142**  
Lord Loxley's (Brian Blessed) Robes  
**Robin Hood:**  
**Prince Of Thieves (1991)**

Lord Loxley's (Brian Blessed) robes from Kevin Reynolds' action-adventure Robin Hood: Prince of Thieves. Loxley wore his robes as he wrote a letter hoping to secure the safe release of his son, Robin (Kevin Costner), who had been taken prisoner in Jerusalem. The robes are made of heavy blue cotton and feature open sides, a square neckline, woven trimmings, and metal studs across the chest. An Angels costumers label is sewn into the interior, which displays a handwritten note reading "Brian Blessed Sept 1990." The robes have been intentionally distressed to appear old and well-worn, and they exhibit minor staining from production use.

**Estimate: \$1,000 - 2,000**

**1143**  
Lord Loxley's (Brian Blessed) Scroll  
**Robin Hood:**  
**Prince Of Thieves (1991)**

Lord Loxley's (Brian Blessed) scroll from Kevin Reynolds' action-adventure Robin Hood: Prince of Thieves. Loxley wrote a letter enquiring about the whereabouts and well-being of his son, Robin (Kevin Costner), who had been taken prisoner in Jerusalem. This scroll features said letter printed in black cursive on vellum paper, which rolls around the scroll bar glued to the top of the sheet. Loxley's signature has been handwritten in black ink. Dimensions: (rolled) 15.50" x 2" x 2" (39 cm x 5 cm x 5 cm)

**Estimate: \$1,000 - 2,000**



**1144**  
Script, Production Paperwork,  
and Promotional Banner  
**Robin Hood:**  
**Prince Of Thieves (1991)**

A script, production paperwork, and a promotional banner from Kevin Reynolds' action-adventure Robin Hood: Prince of Thieves. The majority of the paperwork came from stunt coordinator and performer Paul Weston. The lot includes a 133-page proofing copy script; 30 printed storyboard pages; nine call sheets; four pages of headed paper; three compliment slips; four behind-the-scenes photos; six blank and one typed interoffice memos; a stuntman crew list; printed and handwritten lyrics for the song "Love is the Outlaw"; and a large vinyl banner. Some script pages exhibit highlighted dialogue and handwritten annotations. The banner exhibits several small marks. Dimensions: (banner) 119.75" x 46.75" (304 cm x 118.5 cm)

**Estimate: \$1,000 - 2,000**



**1145**  
EM-208 Head  
and Torso Display  
**RoboCop (2014)**

An EM-208 head and torso display from Jose Padilha's sci-fi action remake RoboCop. Numerous droid parts hung from the ceiling during Alex Murphy's (Joel Kinnaman) escape from OmniCorp labs. This lot consists of a 3D-printed resin EM-208 head painted silver and a resin torso display painted black. The display is inset with metal cords on both sides for hanging, while the head sits on the display, which features a decal displaying the film's title. This display exhibits paint chipping and striation lines with noticeable paint bubbling, cracking and chipping, and scuff marks to the head. It has undergone sympathetic restoration. Dimensions: 17" x 18" x 42" (43.25 cm x 45.75 cm x 106.75 cm)

**Estimate: \$1,500 - 3,000**



**1146**  
Detective Badge  
**RoboCop (2014)**

A detective badge from Jose Padilha's sci-fi action remake RoboCop. Alex Murphy (Joel Kinnaman) and other police officers carried their badges throughout the film. This lot consists of a metal badge engraved with "Police Detective OPD Detroit," painted brass-color, and inset into a leather holster with a metal waist clip, and a metal ball-chain necklace. This lot exhibits minor tarnishing of the necklace and snagged threads on the leather. Dimensions: 4" x 3" x 1" (10.25 cm x 7.75 cm x 2.5 cm)

**Estimate: \$600 - 1,200**

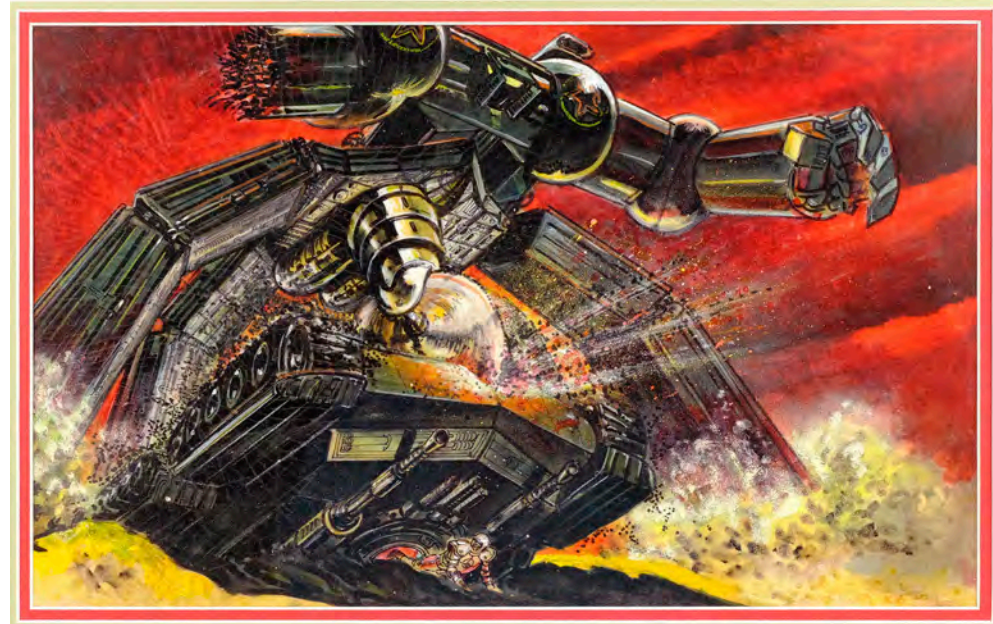

**1147**  
**Framed Hand-Painted**  
**Nikita Knatz Robot Gladiator**  
**Concept Illustration**  
**Robot Jox (1989)**

A framed robot gladiator concept illustration hand-painted by visual consultant Nikita Knatz for Stuart Gordon's sci-fi thriller Robot Jox. In their climactic fight, robot gladiator Achilles (Gary Graham) destroyed Confederation fighter Alexander's (Paul Koslo) robot. This illustration depicting Alexander's robot looming over a fellow fighter is rendered in mixed media on paper and signed by Knatz in the bottom right corner. It comes mounted behind glass in a custom black wooden frame. The illustration exhibits visible crinkling. Dimensions: 17" x 11" x 1" (43.25 cm x 28 cm x 2.5 cm) Sold without copyright; see notice in the Buyer's Guide.

**Estimate: \$400 - 800**

**1148**  
**Prototype Cliff Secord**  
**(Billy Campbell) Rocket Pack with**  
**Stunt Flying Guideline Storyboards**  
**The Rocketeer (1991)**

A prototype of Cliff Secord's (Billy Campbell) rocket pack with stunt flying guideline storyboards from Joe Johnston's action adventure film The Rocketeer. Cliff and Peevy (Alan Arkin) discovered a duffle bag containing a Cirrus X3 rocket pack in the seat of their "Miss Mabel" aircraft. This lot consists of a carved foam rocket pack prototype created by production as a mold for the final fiberglass versions of the rocket pack and painted silver, as well as a packet of storyboards depicting Cliff operating the rocket pack printed in black-and-white by production. This lot exhibits various dents and chipped paint from production use. Dimensions: 18.5" x 16.5" x 6" (47 cm x 42 cm x 15.25 cm)

**Estimate: \$5,000 - 10,000**



**1149**  
**James Garner's Goodyear Racing Jacket**  
**Rockford Files (1974-1980)**

James Garner's Goodyear racing jacket promoting Steven J. Cannell's detective drama television series The Rockford Files. Outside of acting, Garner was an avid racing enthusiast known for driving his Oldsmobile 442 "Goodyear Grabber," and often wore various apparel promoting his sponsor during races. This steel blue, nylon quilted-pattern, polyester-filled racing jacket features two waist pockets, a sewn-on embroidered "THE ROCKFORD FILES" and "JIM" patch in a two-tone yellow and black motif atop the left snap-button pocket, and a sewn-on blue twill fabric patch atop the right breast with a white embroidered Goodyear logo. It exhibits minimal signs of discoloration, including yellowing to the logo, minor interior staining, and loose threads from use.

**Estimate: \$2,000 - 4,000**



**1151**  
**Padded Chairback**  
**Rocky Balboa (2006)**

A padded chairback from the production of Sylvester Stallone's sports drama sequel Rocky Balboa. Directors chairs with custom chairbacks were provided by production for cast, crew, and guests. This lot consists of a navy blue canvas chairback with internal padding for comfort as well as the film's title logo with an image of Stallone as Balboa on one side and the name "Balboa" on the other, both in yellow font. It exhibits some wear from use and age, including loose stitches and cracking in the lettering. Dimensions: 22" x 8" x 2" (56 cm x 20.5 cm x 5.25 cm)

**Estimate: \$700 - 1,400**



**1150**  
**Set of Three Hand-Drawn Fred Lucky**  
**"Balboa vs. Lang" Storyboards**  
**Rocky III (1982)**

Three "Balboa vs. Lang" storyboards hand-drawn by storyboard illustrator Fred Lucky from the production of Sylvester Stallone's sports sequel Rocky III. Under the coaching of Apollo Creed (Carl Weathers), Rocky Balboa (Stallone) faced off against Clubber Lang (Mr. T) for the title of World Champion. These storyboards for the iconic final fight sequence are rendered in mixed media on bordered drawing paper and vellum. Shot descriptions, scene numbers, and dialogue samples are also handwritten throughout the margins. The storyboards exhibit ink smudging and small pinholes from hanging. Dimensions: (each) 8.5" x 11" (21.75 cm x 28 cm) Sold without copyright; see notice in the Buyer's Guide.

**Estimate: \$400 - 800**

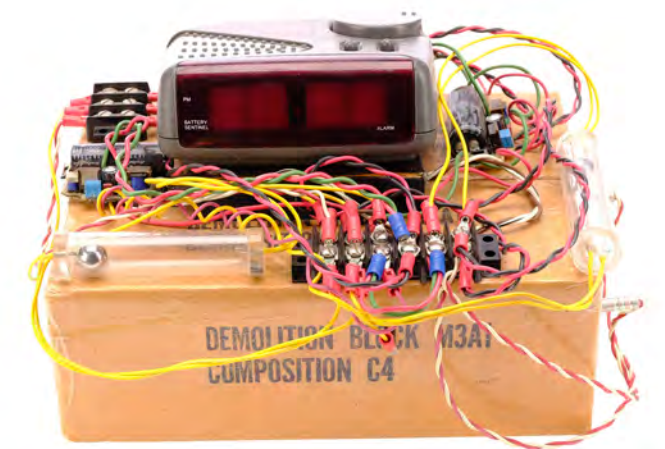

**1152**  
**Time Bomb**  
**Rush Hour (1998)**

A time bomb from Brett Ratner's action-comedy Rush Hour. Johnson (Elizabeth Pena) practiced disarming a bomb when Carter (Chris Tucker) and Lee (Jackie Chan) approached her for help. This lot consists of a time bomb with two wooden C4 blocks, multicolor cables connecting the C4 blocks to a plastic digital clock, and clear acrylic tubes with metal balls. Included is a photo image of the bomb and other bombs used during the film. This lot exhibits grime from age, two holes in one of the C4 blocks from production use, and a nonfunctional digital clock. Dimensions: 10" x 7.5" x 6" (25.5 cm x 19 cm x 15.25 cm)

**Estimate: \$1,500 - 3,000**





**1153**  
James Carter's (Chris Tucker) Driver's License with Solon Han's (Tzi Ma) Business Cards and Soo Yung Han (Julia Hsu) Photos  
**Rush Hour (1998)**

James Carter's (Chris Tucker) driver's license with Solon Han's (Tzi Ma) business cards and Soo Yung Han (Julia Hsu) photos from Brett Ratner's action comedy Rush Hour. LAPD detective Carter took Consul Han's business card when he and Chief Inspector Lee (Jackie Chan) investigated the kidnapping of Han's daughter. This lot consists of a plastic California driver's license with a color-printed picture of Carter, biographical information, and number "791379"; four English-language cream, red, and black business cards for "Solon Han"; two matching Chinese-language cards; and four color photographs of Soo Yung. The lot exhibits some bending throughout from production. Dimensions: (largest) 2.75" x 4" (7 cm x 10.25 cm)

**Estimate: \$1,200 - 2,400**



**1155**  
Jackie Chan's Chairback  
**Rush Hour (1998)**

Jackie Chan's chairback from Brett Ratner's action film Rush Hour. This red canvas hairback is embroidered "Rush Hour" in white thread and "Jackie Chan" in gold-color thread over the production's dragon logo, which is printed in black on front. It exhibits white stains on the top and bottom edges from being affixed to a director's chair during production. Dimensions: 8" x 21.5" x 0.25" (20.5 cm x 54.75 cm x 0.75 cm)

**Estimate: \$600 - 1,200**



**1154**  
Pair of Foo Chow Menus  
**Rush Hour (1998)**

A pair of Foo Chow menus from Brett Ratner's action comedy Rush Hour. Menus appeared in the Foo Chow restaurant where Juntao (Tom Wilkinson) hid his criminal enterprise. Both of these glossy red and goldenrod paper menus feature the Foo Chow restaurant logo on the front with vinyl Chinese text and two pages of menu options on their interior. The pair exhibit grime from age and various stains from production use. Dimensions: 15" x 9.5" (38.25 cm x 24.25 cm)

**Estimate: \$300 - 600**



**1156**  
Confederate States of America Gold Case  
**Sahara (2005)**

A Confederate States of America gold case from Breck Eisner's action adventure Sahara. At the beginning of the film, Members of the Confederate States of America (CSA) loaded the Ironclad with cases of gold which Al Giordino (Steve Zahn) later found in a cave. This sealed rubber case is hand-painted silver-color and red to resemble metal, affixed on both sides with rope and wooden handles, and stenciled "CSA" in black text on the top and front. It exhibits paint scuffing, fraying rope, and fading stenciling from production use and age. Dimensions: 23" x 13" x 6.5" (58.5 cm x 33 cm x 16.5 cm)

**Estimate: \$600 - 1,200**



**1157**  
Screen-Matched Sidney Prescott (Neve Campbell) Police File  
**Scream 3 (2000)**

A screen-matched Sidney Prescott (Neve Campbell) police file from Wes Craven's slasher sequel Scream 3. Sidney discovered her police file while she waited at the police station. This lot consists of one folder with three inner tabs filled with paperwork. Bound by brass brads, this file features an assortment of print photographs in color and black-and-white; news article clippings; sticky notes; and hand-written annotations in ink and highlighter that screen-match to the file as Prescott flips through it. This lot exhibits fading, some discoloration, mild tears and fragile components. Dimensions: 19.5" x 12" x 0.5" (49.5 cm x 30.5 cm x 1.25 cm)

**Estimate: \$800 - 1,600**



**1159**  
Set of Sacred Heart Hospital Staff Badges  
**Scrubs (2001)**

Sacred Heart Hospital staff badges from Bill Lawrence's medical comedy series Scrubs. Medical personnel at Sacred Heart wore staff badges throughout the series. This set consists of 18 plastic badges in clear plastic cases with metal clips labeled for the following: "John Dorian", aka JD (Zach Braff); "Taylor Maddox" (Courteney Cox); "Kim Wyatt" (Elizabeth Banks); "Todd Quinlan" (Robert Maschio); "Lucy Bennett" (Kerry Bishe); "Cole Aaronson" (Dave Franco); "Keith Dudemeister" (Travis Schuldt); "Derek Hill" (Lee Thompson Young); "Drew Suffin" (Michael Mosley); "Jimmy Groper" (Taran Killam); "Milos Radovichovnicivsik" (Benjamin King); "Bob Bencomo," aka Colonel Doctor (Bob Bencomo); "Phillip Wen" (Charles Rahi Chun); "D. Murphy" (Johnny Kastl); "Lisa Bolton" (Jordan Zucker); "Collins Genesis"; "Joyce Papsen"; and "Stu Peedo." They exhibit scratching and scuffing throughout. Dimensions: (each) 4.25" x 3" (11 cm x 9 cm)

**Estimate: \$1,500 - 3,000**



**1158**  
Scarecrow Ghostface Mask  
**Scream 4 (2011)**

A scarecrow Ghostface mask from Wes Craven's slasher sequel Scream 4. During the Stabathon movie marathon, audience members dressed up in Father Death costumes and masks. Originating from a crew member, this lot consists of one mask displayed on a black flocked styrofoam head. Commemorating Scream 4's release, filmmakers produced a small line of masks for extras to wear. This mask features a burlap-covered Ghostface-shaped mask attached to a brown burlap hood. The back of the hood features an open seam and white strips of self-fasteners. It also features two twine ties. The eyes were modified with dark mesh fabric. This lot exhibits notable snagged and loose threads and some fiber fragility.

**Estimate: \$800 - 1,600**



**1160**  
River Tam's (Summer Glau) Costume  
**Serenity (2005)**

River Tam's (Summer Glau) costume from Joss Whedon's sci-fi adventure film Serenity. River wore her costume when a heist went bad. This lot consists of a pair of black rubber goggles with glass lenses; an underdress made from segments of tie-dyed material assembled in a patchwork design; a brown spandex blend top with a long left sleeve and multicolor mesh netting; and two pairs of personal undergarments. The goggles' band exhibits four small holes.

**Estimate: \$3,000 - 6,000**



**1161**  
River's (Summer Glau) Screen-Matched Funeral Costume  
**Serenity (2005)**

River's (Summer Glau) screen-matched funeral costume from Joss Whedon sci-fi adventure movie Serenity. River wore her funeral costume towards the end of the film, when they finally mourned the loss of their friends who fell in the fight against the Alliance. This piece can be screen-matched by its distinctive patterning as worn in the funeral scenes. This costume consists of a dusty pink chiffon halter neck dress (size 4) with a tiered skirt and black polka dot pattern, and pink and silver-color flats with an ankle strap. Also included is a production-tag featuring hand-marked information relating to scene and character information. This costume exhibits some mild discoloration and scuffing on the shoes.

**Estimate: \$3,000 - 6,000**



**1162**  
Wash's (Alan Tudyk) Hawaiian Shirt and T-Shirt  
**Serenity (2005)**

Wash's (Alan Tudyk) Hawaiian shirt and T-shirt from Joss Whedon sci-fi adventure Serenity. Wash, the ship's pilot, wore his shirts beneath his flight suit while onboard Serenity until the crew left for the Maidenhead Bar. This cotton Hawaiian short-sleeve shirt features colorful palm trees, surfing, and hula dancing motifs. The interior collar is hand-marked with a "W." The polyblend orange T-shirt (size L) also features a hand-marked "W" on the interior collar. Also included is a production tag hand-marked with scene references and character information. This lot exhibits snagged threads as the seams.

**Estimate: \$1,000 - 2,000**



**1163**  
Inara Serra's (Morena Baccarin) Costume  
**Serenity (2005)**

Inara Serra's (Morena Baccarin) costume from Joss Whedon's sci-fi adventure film Serenity. Inara wore her black and gold-color costume when she accompanied the crew of Serenity to the hidden planet Miranda. This costume consists of a shawl with gold-color swirl patterns and small metallic gold-color stitching throughout; a black velvet bodice featuring ribbing on the front and back, and a zip closure; a strapless black bra (size 32 B) with a hand-marked interior label "Inara" in black ink; a brown silk waist wrap featuring leaf and branch designs; black chiffon culottes with a zipper closure; black cotton underwear (size M); and a pair of shoes (size 37 1/2) made of gold-color synthetic leather. Included with the lot is an original wardrobe tag from production, which notes the articles of the costume and scene information. This costume exhibits snagged and loose threads, and scuffing on the shoes.

**Estimate: \$3,000 - 6,000**



**1164**  
Funeral Ceremony Model Rocket  
**Serenity (2005)**

A funeral ceremony model rocket from Joss Whedon's space western Serenity. The crew of the titular spaceship used a model rocket in the funeral ceremony of the fallen friends near the end of the film. This lot consists of a black metal rocket decorated with black and gold-color decals and orange and red cards with gold-color foil featuring handwritten messages. Some of the paper elements exhibit bending. Dimensions: 19" x 4" x 4" (48.5 cm x 10.25 cm x 10.25 cm)

**Estimate: \$1,000 - 2,000**

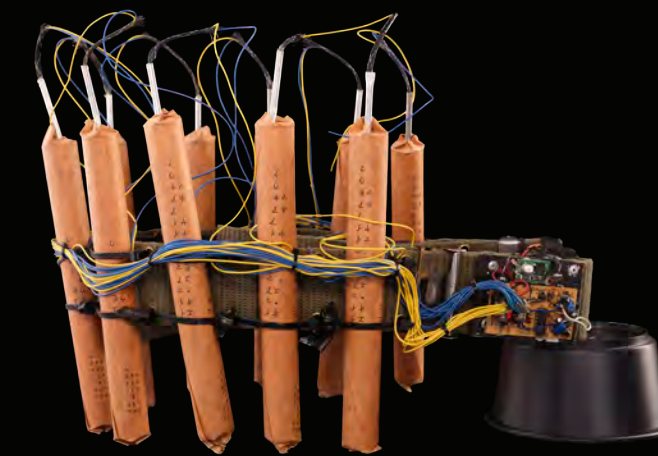

**1165**  
Light-Up Bomb Belt  
**Seven Psychopaths (2012)**

A light-up bomb belt from Martin McDonagh's crime-comedy Seven Psychopaths. Vietnamese priest "Psychopath No. 4" (Long Nguyen) kept a bomb belt beside him when he met with a prostitute. This dark green nylon belt features dynamite wooden sticks wrapped in paper with Asian characters and is secured to the belt with zip ties. They have various yellow and blue cables connecting to a battery operated light-up panel that functions by a small toggle near the battery. This lot exhibits grime on the paper coverings and restoration. Dimensions: 17" x 12" x 6" (43.25 cm x 30.5 cm x 15.25 cm) Contains electronics; see electronics notice in the Buyer's Guide.

**Estimate: \$800 - 1,600**



**1166**  
Marilyn Monroe Limited Edition Print - George Barris  
**The Seven Year Itch (1955)**

A limited edition portrait of Marilyn Monroe from the production of Billy Wilder's romantic comedy The Seven Year Itch. The photograph was taken and signed by acclaimed photojournalist George Barris and captures a smiling Monroe posing while wearing a white robe. The framed portrait is presented behind glass within a cream-color photo mount. It comes with a Certificate of Authenticity from One West Publishing confirming that it is one of 50 that were printed. Dimensions: 29.25" x 23" x 1.5" (74 cm x 58 cm x 4 cm) Sold without copyright; see copyright notice in the Buyer's Guide.

**Estimate: \$1,000 - 2,000**



**1167**  
Carrie's (Sarah Jessica Parker) Autographed Shoes  
**Sex And The City (2008)**

Carrie's (Sarah Jessica Parker) autographed shoes from the HBO sitcom Sex and the City. This pair of silver-color kitten heels (size 38) include long leather ankle straps and a silver-color embellishment on the silk toe straps. Each shoe features Jessica Parker's autograph signed on the soles in black pen. Accompanying the shoes is a HBO certificate of authenticity dated "12/10/07" and signed by the production's costume designer. The shoes exhibit minor wear and discolorations from production use and age, and there is a small stain on the COA. Dimensions: (each shoe) 9.75" x 3.5" x 2.25" (24.5 cm x 9 cm x 5.5 cm)

**Estimate: \$800 - 1,600**

61" (155 cm)

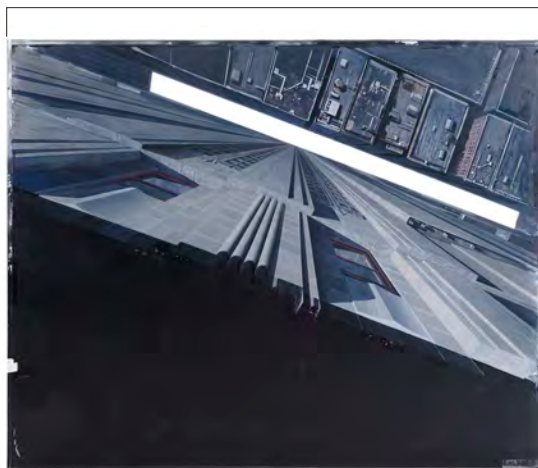

**1168**  
Double-Sided Hand-Painted  
City View Matte Painting  
**The Shadow (1994)**

A double-sided, hand-painted city view matte painting from the production of Russell Mulcahy's superhero film *The Shadow*. Shiwan Khan (John Lone) used his psychic abilities to compel a sailor (Patrick Fischler) to jump off the Empire State Building. This lot consists of two matte paintings rendered in mixed media on opposite sides of a single oversize framed glass panel hand-labeled "MP 10." One depicting an overhead perspective of the Empire State Building is hand-painted by matte artist supervisor Christopher Evans, while the other depicting a street-level view of nearby buildings is painted by special visual effects supervisor Michael Pangrazio. This lot exhibits notable paint marks and flaking. Dimensions: 49.5" x 61" x 0.5" (125.75 cm x 155 cm x 1.5 cm) Special shipping required; see notice in the Buyer's Guide. Sold without copyright; see copyright notice in the Buyer's Guide.

**Estimate: \$1,500 - 3,000**



**1170**  
Silent Hill  
Nurse Costume  
**Silent Hill (2006)**

A *Silent Hill* nurse costume from Christophe Gans' horror film *Silent Hill*. Rose Da Silva (Radha Mitchell) discovered monstrous nurses as she escaped from the hospital in *Silent Hill*. This white spandex dress is covered in sculpted latex painted to resemble flesh, a matching nurse's hat made of latex, and a foam head mask sculpted to resemble a featureless face. The dress fastens at the front using self-fastening strips, and features a hand-marked label for "Sylvia." The nurse's hat features a hand-marked tag for "Nadia." Production intentionally distressed this costume to give it a bloodied, grungy appearance. It exhibits tears and ripping in the foam and latex.

**Estimate:**  
**\$2,000 - 4,000**



**1169**  
Screen-Matched Shot Bald Eagle  
**Shameless (2011-2021)**

A screen-matched shot bald eagle from Paul Abbott and John Wells' comedy-drama series *Shameless*. The paint imperfections on the feet screen-match this bald eagle from the Season 2 episode "Just Like the Pilgrims Intended" where Carl Gallagher (Ethan Cutkosky) shot a bald eagle, thinking it was a duck, for Thanksgiving. This styrofoam bald eagle has a feather coating, painted resin feet and beak, a metal tracker, a bullet wound to the left shoulder, and is covered in stage blood. Included with the bald eagle is a wooden display case with a turf grass lining, metal trim and an acrylic panel for viewing. This lot exhibits chipping paint on the feet and beak. Dimensions: 32" x 14" x 8" (81.5 cm x 35.75 cm x 20.5 cm)

**Estimate: \$2,000 - 4,000**



**1171**  
Pat's (Bradley Cooper)  
Costume  
**Silver Linings Playbook (2012)**

Pat's (Bradley Cooper) costume from David O. Russell's romantic-comedy *Silver Linings Playbook*. Pat wore his costume when he walked Tiffany (Jennifer Lawrence) home from her sister Veronica's (Julia Stiles) house. This lot consists of a white polyester NFL Eagles Jackson 10 jersey (size 50) with team and midnight green patches; one white (size XL) and one gray (size L) cotton shirt; brown cotton (33x32) trousers; a brown leather belt; a black bound Academy Award Nominee booklet with disks for Best Adapted Screenplay and *The Making of Silver Linings Playbook*; an 8.5" x 11" color continuity photo; and a production tag. This lot exhibits stains on the jersey from production use.

**Estimate:**  
**\$800 - 1,600**



**1172**  
Bughuul Bust Display  
**Sinister 2 (2015)**

A Bughuul bust display from Ciaran Foy's horror sequel *Sinister 2*. The Bughuul (Nicholas King) possessed children, who then murdered their families. Professionally applied to a resin bust for display purposes, this lot consists of a mask and a black synthetic wig glued on for stability. The mask is made of foam latex and painted to resemble mottled flesh with dark eye sockets, exaggerated eyebrows, and dark shading where the mouth would be. Both the mask and wig are screen used while the suit is a replica piece added for display. It's dressed in a salmon-color cotton button up and black wool suit jacket. This lot exhibits frayed fibers and pilling. Dimensions: 12" x 9.5" x 24" (30.5 cm x 24.25 cm x 61 cm)

**Estimate: \$3,000 - 6,000**



**1173**  
Production-used Clapperboard  
**Sleepy Hollow (1999)**

A production-used clapperboard from Tim Burton's fantasy horror *Sleepy Hollow*. Used by the "A" camera unit during filming, the clapperboard is an acrylic slate with a wooden clapper fixed to the top. It features the production title "Sleepy Hollow" and the names of director Tim Burton and director of photography Peter Hannan, all engraved in red. Outlined boxes divide the piece into fields titled "roll," "scene," and "take," all of which contain handwritten details in black marker pen. A strip of tape is adhered along the bottom edge and reads "17-4-99, Night Exterior." It exhibits notable scuffing on the arm, and the edges of the tape have begun to peel. Dimensions: 9.5" x 11.25" x 1.5" (24 cm x 28.5 cm x 4 cm)

**Estimate: \$3,000 - 6,000**



**1174**  
Jack-O'-Lantern  
**Sleepy Hollow (1999)**

A jack-o'-lantern from Tim Burton's fantasy horror *Sleepy Hollow*. The village of *Sleepy Hollow* was decorated with jack-o'-lanterns, including at the home of Baltus (Michael Gambon) and Lady Mary Van Tassel (Miranda Richardson), when Ichabod Crane (Johnny Depp) first arrived. This lot consists of a fiberglass jack-o'-lantern, painted orange with yellow inside the cut-out face, with a removable top featuring a small black stem. The pumpkin and top are marked "17." It exhibits scuffing throughout the painted finish. Dimensions: 13" x 12" x 8" (33.25 cm x 30.5 cm x 20.5 cm)

**Estimate: \$2,500 - 5,000**



**1175**  
Ichabod Crane's  
(Johnny Depp) Scythe Δ  
**Sleepy Hollow (1999)**

Ichabod Crane's (Johnny Depp) scythe from Tim Burton's fantasy horror Sleepy Hollow. Ichabod used his scythe when he and Brom (Casper Van Dien) fought off the Horseman after he killed the Killian family. This lot consists of a scythe with a metal blade fixed to a lightweight straight snath made of foam finished with a faux wood wrapping. The base of the snath remains incomplete and reveals the interior of the piece. This scythe has undergone sympathetic repair. It exhibits scratching and discoloration on the metal finish. Dimensions: 53" x 10.5" x 1.5" (134.75 cm x 26.75 cm x 4 cm) Blade was dulled by production.

**Estimate:**  
**\$2,000 - 4,000**



**1176**  
Headless Horseman's  
(Craig Branham)  
Costume and Ax  
**Sleepy Hollow  
(2013-2017)**

Headless Horseman's (Craig Branham) costume and ax from the adventure-crime series Sleepy Hollow. The ax-wielding Headless Horseman wore his costume as he rode his horse through Sleepy Hollow. Designed by Kristin M. Burke, this lot consists of a black-painted dense rubber ax; gray trousers with black nylon suspenders and gold-color metal buttons; a red and blue wool overcoat with gold-color metal buttons and coiled wire epaulets; a beige linen long-sleeve blouse; a gray and purple rayon vest with gold-color buttons; a beige ascot; black leather boots; a brown leather harness; one black and brown leather glove with silver-color painted rubber covers; a black-painted leather ammo belt with foam shotgun shells; a green nylon mask, a black leather holster belt; a long-sleeve (size L) and tank (size XL) shirts; and nine production tags. All are marked "Stunt DBL Riding." This lot exhibits intentional distressing from production with black paint. Dimensions: (ax) 47" x 12" x 2" (119.5 cm x 30.5 cm x 5 cm)

**Estimate:**  
**\$3,000 - 6,000**



76" (193 cm)

**1177**  
Hand-Painted Tire Town  
Matte Painting  
**Solarbabies (1986)**

A hand-painted Tire Town matte painting from Alan Johnson's sci-fi film Solarbabies. Orphans arrived at Tire Town in search of the alien orb Bodhi that Darstar (Adrian Pasdar) took. This lot consists of one hand-painted matte painting on a metal-framed acrylic panel. The hilly desertscape features three smokestacks and an unpainted town. The frame bottom features a plaque with the film's name and hand-marked strips of tape: one is marked "1," the others, illegible. It exhibits notable paint marks, scuffs, and adhesive residue. Dimensions: 76" x 34" x 0.5" (193 cm x 86.5 cm x 1.25 cm) Special shipping required; see notice in the Buyer's Guide. Sold without copyright; see copyright notice in the Buyer's Guide.

**Estimate: \$1,000 - 2,000**



80" (203.25 cm)

**1178**  
Hand-Painted Gorge Jump  
Matte Painting  
**Solarbabies (1986)**

A hand-painted gorge jump matte painting from Alan Johnson's sci-fi film Solarbabies. The orphans jumped the gorge to evade the E-Police as they chased after Daniel (Lukas Haas). This lot consists of one hand-painted matte painting on particle board. It features the image of a desert gorge with a broken bridge on one side. This lot exhibits scuffing, chipped edges, notable paint marks, and blue tape. Dimensions: 80" x 38" (203.25 cm x 96.5 cm) Special shipping required; see notice in the Buyer's Guide. Sold without copyright; see copyright notice in the Buyer's Guide.

**Estimate: \$1,000 - 2,000**



**1179**  
Framed Cast-Autographed  
Make-A-Wish Foundation Plate  
**The Sopranos (1999-2007)**

A framed plate autographed by the cast of HBO's landmark drama series The Sopranos. Custom-made for the Make-A-Wish Foundation, this white porcelain plate with gold-color rimmed borders and the series logo printed in red is signed, annotated, and speckled with pink and blue dots in various inks by James Gandolfini, Edie Falco, Michael Imperioli, Lorraine Bracco, Tony Sirico, Drea de Matteo, Steven Van Zandt, Jamie-Lynn Sigler, Dominic Chianese, Aida Turturro, Robert Iler, and Federico Castelluccio. The plate comes mounted behind glass above a label reading "Cast of The Sopranos" inside a black wooden frame. The plate exhibits minor scratching. Dimensions: 16" x 17" x 2.5" (40.75 cm x 43.25 cm x 6.5 cm)

**Estimate: \$3,500 - 7,000**



**1180**  
Serververse White Walker Mask  
**Space Jam: A New Legacy (2021)**

A Serververse White Walker mask from Malcolm D. Lee's comedy sequel Space Jam: A New Legacy. White Walkers from Game of Thrones, a Warner Bros. property, appeared in the audience when Al G. Rhythm (Don Cheadle) challenged LeBron James to a basketball game in the Warner Bros. Serververse. Created by KNB EFX Group, this foam latex mask is hand-painted white and gray and punched with synthetic white hair. It features a fastening strip closure on the reverse and a production tag hand-labeled for "Peter Juffer." The mask comes mounted to a foam bust for stability. It exhibits minor tears at the neck, and the bust exhibits some stains from production use.

**Estimate: \$600 - 1,200**



**1181**  
Yogurt's (Mel Brooks)  
Schwartz Ring and Lone Starr's  
(Bill Pullman) Medallion Necklace  
**Spaceballs (1987)**

Yogurt's (Mel Brooks) Schwartz ring and Lone Starr's (Bill Pullman) medallion necklace from Mel Brooks' sci-fi-comedy film Spaceballs. Yogurt wore his Schwartz ring when Lone Starr asked about his medallion necklace from his childhood. This lot consists of a 3-tiered metal oval ring featuring a black resin filling and rhinestones forming an "S" and a circular metal medallion with a hammered texture and embossed foreign language lettering. The medallion, which differs slightly from the version seen onscreen, is attached to a 20" long silver-colored metal chain. This lot exhibits tarnishing from age throughout.

**Estimate: \$2,000 - 4,000**



**1182**  
DARPA Armor  
**Spectral (2016)**

DARPA armor from Nic Mathieu's paranormal action film Spectral. DARPA (Defense Advanced Research Projects Agency) soldiers wore armor to battle hyperspectral anomalies. This lot consists of one nylon, leather, and polyester jacket; matching trousers; one polyester-elastane blend undershirt; Spandex-polyester blend compression trousers; one armored vest made of resin, urethane, polyester, and nylon; one set of leg armor made of resin, urethane, polyester, and leather; urethane, leather, and cotton gloves; and leather, nylon, polyester, and rubber boots. The costume has been marked throughout for "Ga'spa'r Szabo." It was intentionally distressed by production, but exhibits some additional wear from use, including scuffing and staining.

**Estimate: \$3,000 - 6,000**



**1183**  
Set of Five  
Daily Bugle Newspaper Covers  
**Spider-Man (2002)**

Five Daily Bugle newspaper covers from Sam Raimi's superhero film Spider-Man. J. Jonah Jameson's (J.K. Simmons) Daily Bugle critiqued Spider-Man's (Tobey Maguire) every move throughout the film. This set consists of five production-made, color-printed newspaper covers headlined "Who is Spider-Man?," "Spider-Man: Super-Hero or Super-Zero?," "Police Seek Spider-Man!," "Enough!," and "Vigilante Evades Police!" alongside pictures of Spider-Man. The interior and back pages feature unrelated filler stories and advertisements. The set exhibits vertical fold lines and edge wear throughout from production use. Dimensions: (each) 15" x 11.5" (38.25 cm x 29.25 cm)

**Estimate: \$2,000 - 4,000**



**1184**  
Pair of Daily Bugle Newspaper Covers  
**Spider-Man (2002)**

Two Daily Bugle newspaper covers from Sam Raimi's superhero film Spider-Man. After he embraced the mantle of Spider-Man, a despondent Peter Parker (Tobey Maguire) saw Daily Bugle papers that urged the superhero's capture. These production-made, color-printed Daily Bugle newsstock covers are headlined "Wanted! Citizens Call for Wall-Crawler's Arrest" alongside a picture of Spider-Man credited to Parker and "Spider-Man's Reign of Terror!" with a picture of Spider-Man confronting a criminal, respectively, with filler text on both sides. Both exhibit vertical fold lines and minor edge wear from production. Dimensions: (each) 11.5" x 15" (29.25 cm x 38.25 cm)

**Estimate: \$1,000 - 2,000**



**1185**  
Spider Box Prop and Crew Screening Invitation  
**Spider-Man (2002) / Spider-Man 2 (2004)**

A spider box prop and crew screening invitation from Sam Raimi's Spider-Man and Spider-Man 2. Peter Parker (Tobey Maguire) visited a local university where they created genetically designed super spiders stored in display boxes. Production distributed private screening invitations to the cast and crew of Spider-Man 2. This lot consists of a clear acrylic box containing a black plastic spider, faux spider webs, and a wooden stick. Included is a crew screening invitation card to Spider-Man 2 dated June 28, 2004. This lot exhibits grime from age and creases to the invitation. Dimensions: (card) 5" x 7" (12.75 cm x 18 cm); (box) 4" x 4" x 5" (10.25 cm x 10.25 cm x 12.75 cm)

**Estimate: \$600 - 1,200**



**1186**  
Doc Ock's (Alfred Molina) Tentacle Claw  
**Spider-Man 2 (2004)**

Doc Ock's (Alfred Molina) tentacle claw from Sam Raimi's action-sci-fi film Spider-Man 2. After a failed science experiment, Dr. Otto Octavius was fused with mechanical tentacles that earned him the villain name of Doc Ock as he tried to recreate his experiment. This metal tentacle claw features three closed prongs with two having yellow paint at the base. The base of the tentacle claw is marked "Closed Heavy Weight 1 Head" in black marker. This tentacle claw exhibits intentional distressing from production along the prong seams to resemble rust and light welding. Dimensions: 15" x 5.5" x 5.5" (38.25 cm x 14 cm x 14 cm)

**Estimate: \$3,000 - 6,000**



**1187**  
Set of Three Daily Bugle Newspaper Covers  
**Spider-Man 2 (2004)**

Three Daily Bugle newspaper covers from Sam Raimi's superhero sequel Spider-Man 2. Run by editor J. Jonah Jameson (J.K. Simmons), the Bugle ran story after story criticizing Spider-Man's (Tobey Maguire) crime-fighting spree. This set consists of three color-printed, production-made newspaper covers, one each with the headlines "Spidey's Tribute," "Doc Ock' Still At Large," and "Spider-Man No More." Two covers feature pictures of Spider-Man attributed to "Peter Parker" and "Eddie Brock," while one features a printed illustration of Otto Octavius (Alfred Molina). The covers exhibit fold corners and vertical fold lines from production. Dimensions (each): 15" x 11.5" (38.25 cm x 29.25 cm)

**Estimate: \$1,500 - 3,000**

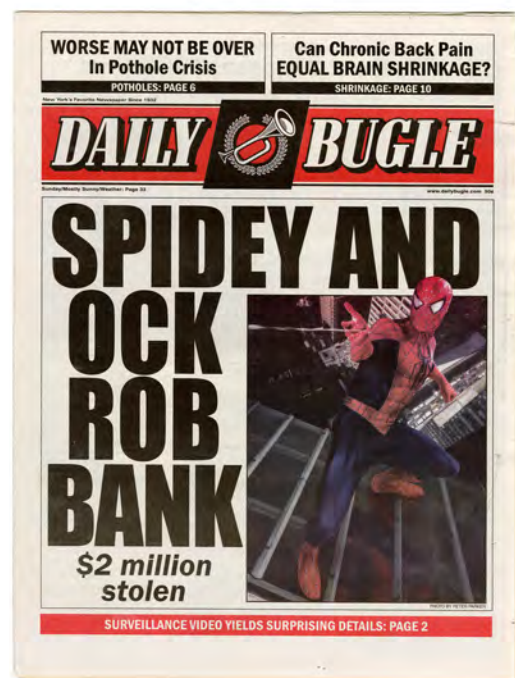

**1188**  
 "Spidey and Ock Rob Bank"  
 Daily Bugle Newspaper  
 Spider-Man 2 (2004)

A Daily Bugle newspaper headlined "Spidey and Ock Rob Bank" from Sam Raimi's superhero sequel Spider-Man 2. Spider-Man (Tobey Maguire) attempted to stop a bank robbery by Doctor Octopus (Alfred Molina), but his deeds were misrepresented in the Daily Bugle newspaper. This lot consists of a production-made, color-printed newspaper cover headlined "SPIDEY AND OCK ROB BANK" along with a color image of Spider-Man. The cover is applied over a pre-existing newspaper interior by production. The cover exhibits tearing in multiple places along the edges, and the other pages exhibit various tears as well. Dimensions: 15" x 11.5" (38.25 cm x 29.25 cm)

**Estimate: \$1,000 - 2,000**



**1189**  
 "Why NY Loves Spidey"  
 New York Magazine  
 Spider-Man 3 (2007)

A New York Magazine headlined "Why NY Loves Spidey" from Sam Raimi's superhero sequel Spider-Man 3. Spider-Man (Tobey Maguire) appeared on the covers of several famous publications at a New York City newsstand. This lot consists of a production-made glossy color-printed magazine cover headlined "WHY NY LOVES (heart) SPIDEY" next to a color image of Spider-Man applied over a pre-existing magazine. It exhibits bending to the cover and edge wear throughout from production and handling. Dimensions: 11" x 8.5" (28 cm x 21.75 cm)

**Estimate: \$800 - 1,600**



**1190**  
 Hikaru Sulu's (George Takei)  
 Helm Station Control Panel  
 Star Trek: The Motion Picture (1979)

Hikaru Sulu's (George Takei) helm station control panel from Robert Wise's sci-fi film Star Trek: The Motion Picture. As the Enterprise helmsman, Sulu helped fly the ship with his control panel. This lot consists of a black acrylic panel designed to appear illuminated when backlit. It features 38 clear buttons and a yellow half-cylindrical light cover. When illuminated from behind, the panel shows labels for "Neural Command Override" and "Comp Monitor In Put." The rear has an acrylic box held in place with metal screws and a metal spring attached to a tab. Included is a 10" x 7" (25.5 cm x 18 cm) production photography sheet. This lot exhibits adhesive residue and scratches on the panel's finish. Dimensions: 9.25" x 7" x 1" (23.5 cm x 18 cm x 2.75 cm)

**Estimate: \$3,000 - 6,000**

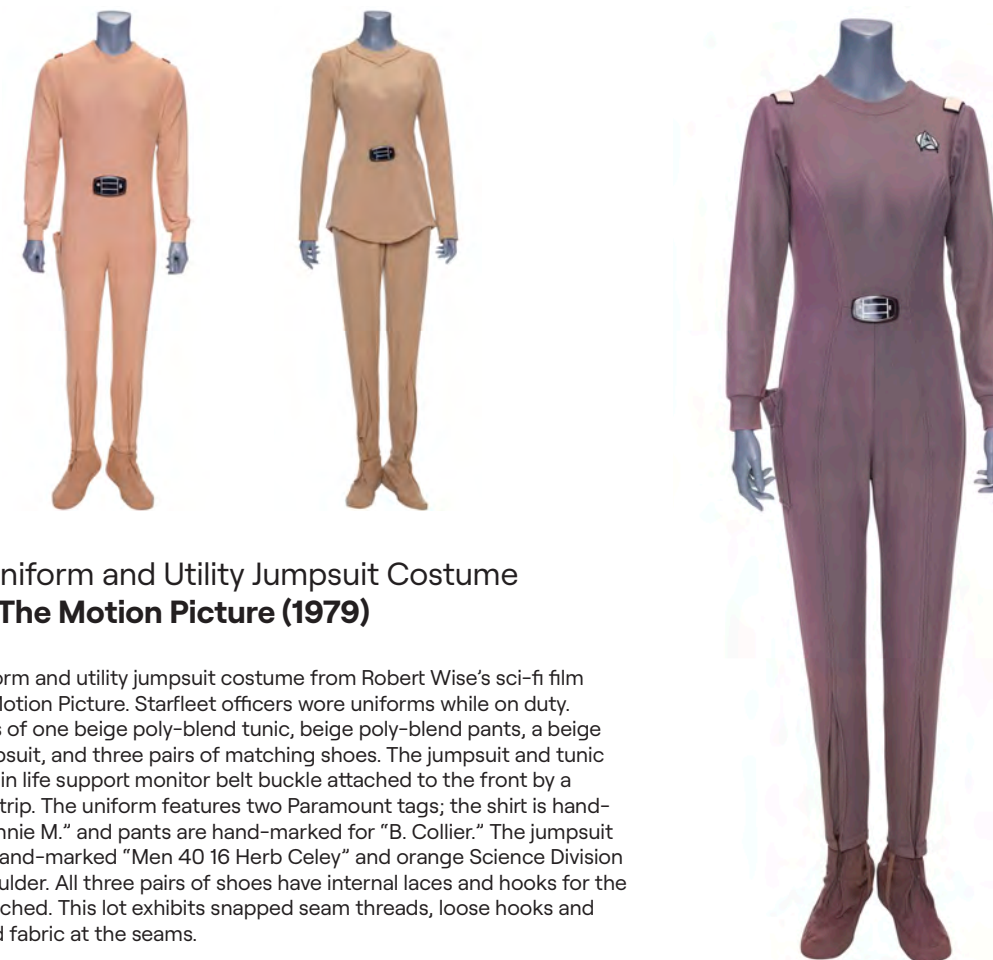

**1191**  
 Starfleet Uniform and Utility Jumpsuit Costume  
 Star Trek: The Motion Picture (1979)

A Starfleet uniform and utility jumpsuit costume from Robert Wise's sci-fi film Star Trek: The Motion Picture. Starfleet officers wore uniforms while on duty. This lot consists of one beige poly-blend tunic, beige poly-blend pants, a beige poly-blend jumpsuit, and three pairs of matching shoes. The jumpsuit and tunic have a black resin life support monitor belt buckle attached to the front by a self-fastening strip. The uniform features two Paramount tags; the shirt is hand-marked for "Winnie M." and pants are hand-marked for "B. Collier." The jumpsuit features a tag hand-marked "Men 40 16 Herb Celey" and orange Science Division tabs on the shoulder. All three pairs of shoes have internal laces and hooks for the pants to be attached. This lot exhibits snapped seam threads, loose hooks and eyes, and frayed fabric at the seams.

**Estimate: \$2,500 - 5,000**



**1193**  
 Starfleet Operations-Division Uniform  
 Costume  
 Star Trek:  
 The Motion Picture (1979)

A Starfleet Operations division uniform costume from Robert Wise's sci-fi film Star Trek: The Motion Picture. Starfleet officers wore uniforms while on duty. This costume consists of one brown wool tunic with small side slits and matching trousers. The tunic features a gold-color Starfleet insignia patch sewn onto the chest, and the belt on the front has a small self-fastening strip. The tunic also features weights sewn into the lining. Paramount tags sewn into the trousers and tunic have hand-marked "8's." This lot exhibits intense fraying of the fabric at the seams, loosened threads on the snaps, and mildly stretched elastic.

**Estimate: \$1,500 - 3,000**



**1194**  
 Klingon Warrior's  
 Costume Components  
 Star Trek:  
 Various Productions

A Klingon warrior's costume components used across Star Trek movies and television episodes, including Star Trek: The Motion Picture. This lot consists of a black leather and vinyl gorget, two black leather and vinyl gauntlets, a gray leather and metal Disruptor holster, black leather fingerless gloves, a gray foam rubber spine piece, two Klingon emblems, and a black leather belt with a gray resin buckle and an ammo case. The names of various performers are handwritten in black pen on interior labels. The collection exhibits wear from production use and age, including cracks, staining, and hardening of the leather.

**Estimate: \$1,200 - 2,400**

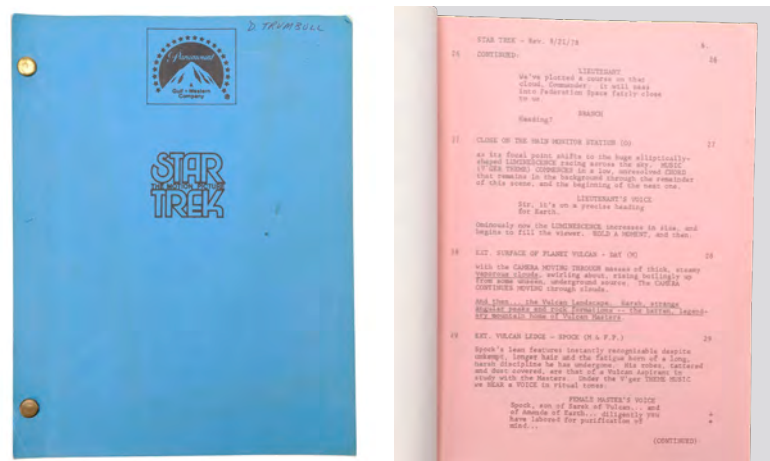

**1195**  
Douglas Trumbull's Personal Shooting Script  
**Star Trek: The Motion Picture (1979)**

Douglas Trumbull's personal shooting script from Robert Wise's sci-fi film Star Trek: The Motion Picture. Visual effects pioneer Douglas Trumbull served as the special photographic effects director for the film. This lot consists of a brass brad-bound, 161-page shooting script dated "July 19, 1978" with a blue cover page featuring the film's title, the Paramount Pictures logo, and "D. Trumbull" handwritten in the top-right corner. It contains many color-coded revision pages from the various changes the script went through over time. It exhibits some corner creasing, edge wear, staining. Dimensions: 8.5" x 11" x 1" (21.75 cm x 28 cm x 2.75 cm)

**Estimate: \$1,500 - 3,000**



**1197**  
Pair of Storyboards and Effects Sequences Binders  
**Star Trek: The Motion Picture (1979)**

Storyboards and effects sequences paperwork from Robert Wise's sci-fi film Star Trek: The Motion Picture. These were used to plan and document the film's special effects. This collection consists of two white vinyl three-ring binders containing 504 storyboard page copies; a paperclip-bound 35-page effect sequences packet; and three production photographs. The storyboards span the film's entirety with printed margin annotations. Two full-color images are hand-marked "X164A 4," and "XMF 2NC 3" in black and red ink. This collection exhibits discoloration, paperclip rust residue, and notable pen marks on the backs of the photographs. Dimensions: 12" x 12.5" x 8" (30 cm x 31.75 cm x 20.5 cm)

**Estimate: \$1,000 - 2,000**

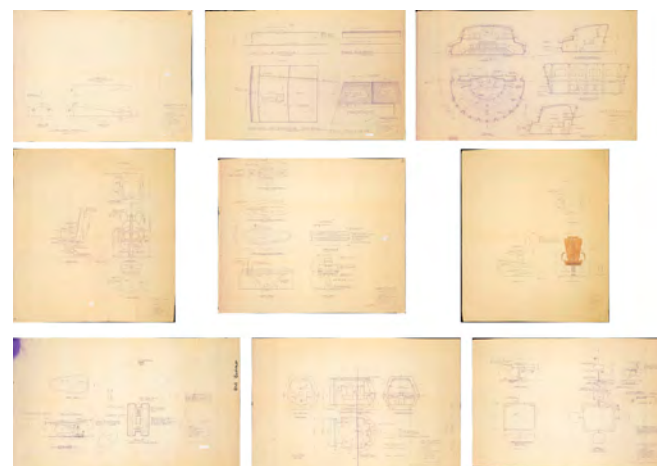

**1196**  
Set of Nine Production Blueprints  
**Star Trek: The Motion Picture (1979)**

A set of nine blueprints from the production of Robert Wise's sci-fi film Star Trek: The Motion Picture. Blueprints were used in the design and construction in many of the film's futuristic sets. This lot consists of a nine blueprint pages for set pieces including the captain's chair, bridge seating for navigation and engineering, tables and chairs for Kirk's quarters, a taxi pod, a sick bay bed, a sick bay examination table, the Epsilon IX station interior, and an Enterprise "Wing Walk" exterior. One of the bridge chair images has been colored in brown and gray. They exhibit varying degrees of yellowing, tearing, and creasing, having been stored rolled with some previously folded. Dimensions: (largest) 42" x 50" (106.75 cm x 127 cm)

**Estimate: \$1,500 - 3,000**



**1198**  
James Kirk, Spock, and Leonard McCoy  
Prototype Decanter  
**Star Trek: The Motion Picture (1979)**

Prototype decanter of James Kirk, Spock, and Leonard McCoy created during the promotion of Robert Wise's sci-fi film Star Trek: The Motion Picture. Grenadier Spirits Co. designed a number of different Cielo Liqueur decanters for the promotion of the film. The Kirk, Spock, and McCoy decanter sculpt was ultimately not chosen for production and release. This lot consists of a fully-painted ceramic decanter in the shape of Kirk sitting with Spock and McCoy standing on either side of him, with the spout's placement on the rear, and a Gotto Enterprises label on the bottom hand-labeled "Sample 8-8-79 Never Produced Grenadier." It exhibits minor scuffing to the base. Dimensions: 5.5" x 6" x 9" (14 cm x 15.25 cm x 23 cm)

**Estimate: \$1,500 - 3,000**



**1199**  
James Kirk Prototype Decanter with Spock Decanter  
**Star Trek: The Motion Picture (1979)**

A prototype decanter of James Kirk and a decanter of Spock created during the promotion of Robert Wise's sci-fi film Star Trek: The Motion Picture. Grenadier Spirits Co. designed a number of different Cielo Liqueur decanters for the promotion of the film. While the Spock decanter was widely produced, the Kirk decanter sculpt was ultimately not chosen for production and release. The two fully-painted ceramic decanters feature removable heads for filling and pouring. The Spock decanter features a "Mr. Spock" label on the bottom with copyright information, while Kirk's is hand-marked "To Jim Proto Type [sic] #1 Captain Kirk" and signed by the artist with the date "2-17-80." Both exhibit minor scuffing, mostly to the bases. Dimensions: 8.5" x 5" x 9.5" (21.75 cm x 12.75 cm x 24.25 cm)

**Estimate: \$1,500 - 3,000**

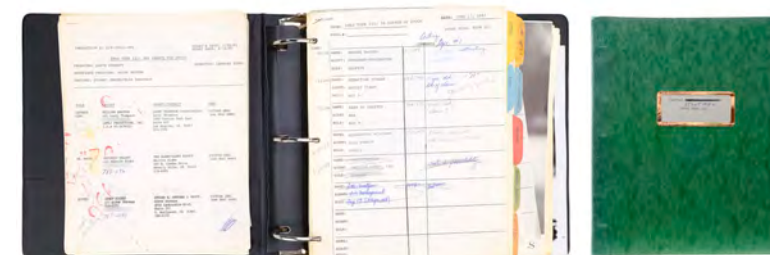

**1201**  
Leonard Nimoy's Annotated Casting Binders with  
Production Ephemera  
**Star Trek III: The Search For Spock (1984)**

Leonard Nimoy's annotated casting books with ephemera from Nimoy's directorial debut Star Trek III: The Search for Spock. Nimoy had a say in the casting, and was keyed into production needs. This lot, originally sourced from Leonard Nimoy's assistant Teresa Victor, consists of two binders: one black plastic three-ring binder organized by character, featuring headshots of performers under consideration, script portions by character, and annotations on decisions regarding their casting; and a second green color patterned three-ring binder with stunt performer headshots, portfolios, and annotations. The lot includes prolific annotated memoranda and other production ephemera, some issued by his personal assistant, Teresa Victor. The lot exhibits edgewear and discoloration from age. Dimensions: 12" x 11.5" x 4.5" (30.5 cm x 29.25 cm x 11.5 cm)

**Estimate: \$2,500 - 5,000**

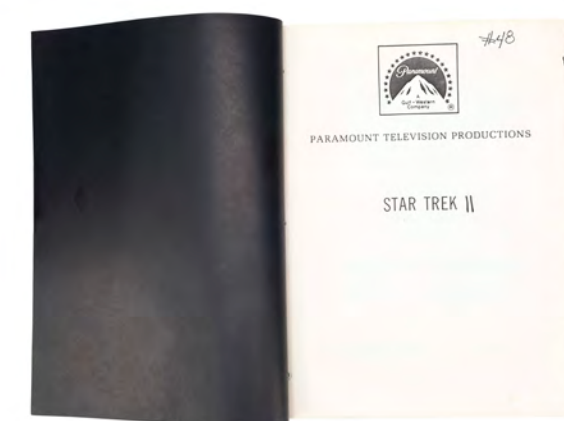

**1200**  
Final Draft Script  
**Star Trek II: The Wrath Of Khan (1982)**

A final draft script from Nicholas Meyer's sci-fi-adventure film Star Trek II: The Wrath of Khan. This 133-page script, written by Jack B. Sowards and Harve Bennett, is titled "Star Trek: The Genesis Project" and dated April 10, 1981. The script comes bound in a black plastic cover featuring a "Star Trek II" sticker on the front and also has "#48" marked on the first page. This script exhibits minor stains and fading ink throughout from age. Dimensions: 8.5" x 11" x 0.5" (21.75 cm x 28 cm x 1.5 cm)

**Estimate: \$600 - 1,200**



**1202**  
Production-Made Kruge (Christopher Lloyd)  
Klingon Makeup Appliances  
**Star Trek III: The Search For Spock (1984)**

Production-made Kruge (Christopher Lloyd) Klingon makeup appliances from Leonard Nimoy's sci-fi sequel Star Trek III: The Search for Spock. Commander Kruge and his crew battled against the crew of the Enterprise in an attempt to steal information on the Genesis Device. This lot consists of four unpainted foam latex appliances, including one large appliance for around the eyes, a full nose, and two alternate nose pieces. The appliances exhibit cracking, staining, and tears along the edges. Dimensions: (largest) 4" x 4" x 1" (10.25 cm x 10.25 cm x 2.75 cm)

**Estimate: \$800 - 1,600**

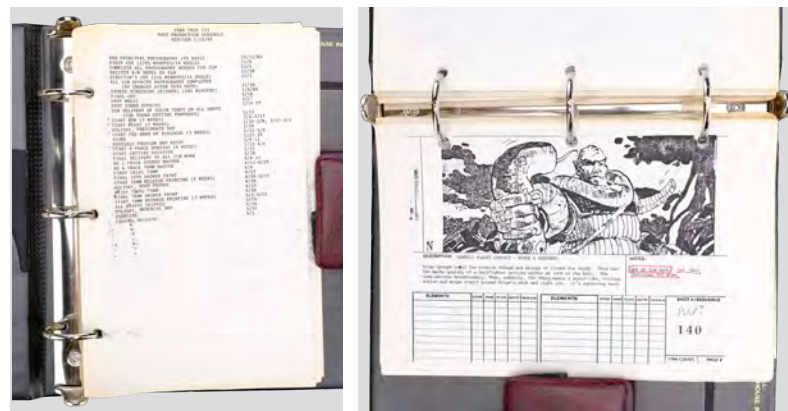

**1203**  
**Binder of Production-Made Storyboard Copies**  
**Star Trek III: The Search For Spock (1984)**

A binder of production-made storyboard copies from Leonard Nimoy's sci-fi sequel Star Trek III: The Search for Spock. Industrial Light & Magic (ILM) used storyboards to plan many complex visual effects sequences. This lot, originally sourced from Leonard Nimoy's assistant Teresa Victor, consists of a brown leather three-ring binder containing 127 pages of photocopied storyboards and supplementary information, with a cover page featuring the film's title logo and the names Nilo Rodis, Dave Carson, and Phil Norwood, with the date "June 1983" and the hand-written marking "Only ILM Boards." The pages exhibit some staining, sticking, corner creasing, and scuffing to the binder. Dimensions: 8.25" x 9" x 2" (21 cm x 23 cm x 5.25 cm)

**Estimate: \$1,000 - 2,000**



**1204**  
**Teresa Victor's Original Shooting Script**  
**with Four Revision Packets**  
**Star Trek III: The Search For Spock (1984)**

Teresa Victor's original shooting script with four revision packets from Leonard Nimoy's Star Trek III: The Search for Spock. Nimoy's personal assistant for 18 years participated behind-the-scenes and as a bit player. This lot consists of scripts from 1983: a 125-page multicolor shooting script with dialogue circled in black ink; 61-page, 23-page, 10-page and 4-page revision packets printed on multicolor paper; and one hand-written note on Paramount stationery in graphite. Scripts are red-stamped "042" throughout, with cover pages featuring Victor's name either hand-written or labeled. The lot exhibits edge wear, creasing, minor staining, and discoloration. Dimensions: 8.5" x 11" x 3" (21.5 cm x 28 cm x 7.75 cm)

**Estimate: \$1,000 - 2,000**



**1205**  
**Klingon Bird of Prey Damage Control**  
**Monitor Transparency Display**  
**Star Trek IV: The Voyage Home (1986)**

A display of a Klingon bird of prey damage control monitor transparency from Leonard Nimoy's sci-fi sequel Star Trek IV: The Voyage Home. The crew of the destroyed Enterprise assessed damage control on the monitors of their commandeered bird of prey, which they renamed the Bounty. This lot consists of an unused, production-made plastic sheet transparency featuring a silhouetted overview of a bird of prey surrounded by grids and other details and Klingon lettering, mounted to glass with a black finish and red gel backings taped in place along with one graphic of the film's title logo and another that describes the piece. The corners of the glass have holes for mounting, and the surface exhibits scratching throughout. Dimensions: 13" x 22" x 0.5" (33.25 cm x 56 cm x 1.5 cm)

**Estimate: \$1,000 - 2,000**



**1206**  
**William Shatner-Autographed**  
**Paradise City Pre-Production Model**  
**Star Trek V: The Final Frontier (1989)**

A William Shatner-autographed pre-production model of Paradise City from William Shatner's sci-fi sequel Star Trek V: The Final Frontier. A simplified model was used to plan out the large set that would portray Paradise City, the settlement on Nimbus III that was taken over by Sybok (Laurence Luckinbill) and his followers. This white foam board model of the settlement was originally won in a charity auction in 1989 and features printed details, hand-written labels including building height revisions, clay embellishments, and a clear plastic dome on one of the buildings. It has been autographed in the center by director and star William Shatner with the note "My Best." The model exhibits light staining, clay cracking, and loose pieces. Dimensions: 29" x 39.5" x 5" (73.75 cm x 100.5 cm x 12.75 cm)

**Estimate: \$3,000 - 6,000**



**1207**  
**Cast- and Gene Roddenberry-Autographed Photo**  
**Star Trek V: The Final Frontier (1989)**

A photo autographed by Gene Roddenberry and the cast of William Shatner's sci-fi sequel Star Trek V: The Final Frontier. The photo, taken for the promotion of the fifth film, depicted the cast in the iconic maroon uniforms they famously wore in Star Trek II through Star Trek VI. This lot consists of a color-printed photo of the main cast on the bridge of the Enterprise-A, and has been signed by Gene Roddenberry, William Shatner, Leonard Nimoy, James Doohan, George Takei, Nichelle Nichols, Walter Koenig, and DeForest Kelley. The photo's glossy finish exhibits a bit of light scratching. Dimensions: 8" x 10" (20.5 cm x 25.5 cm)

**Estimate: \$2,000 - 4,000**

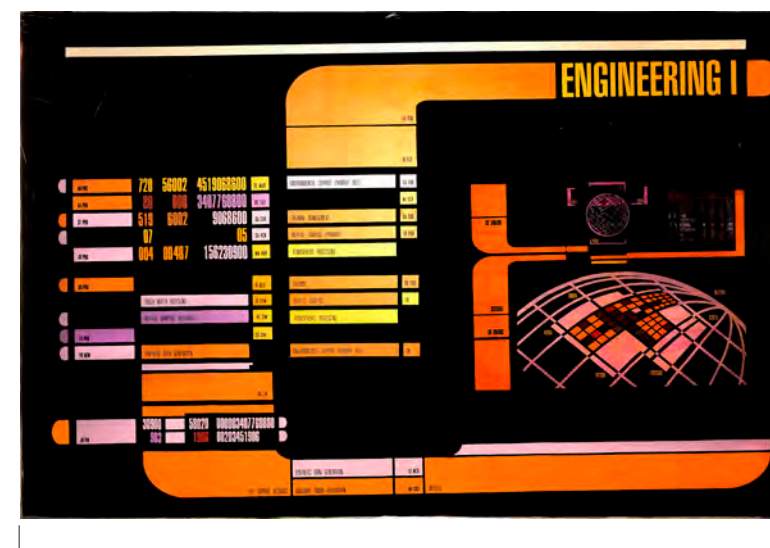

**1208**  
**Engineering I LCARS Panel**  
**Star Trek: Generations (1994)**

An Engineering I LCARS panel from David Carson's sci-fi sequel Star Trek: Generations. The LCARS (Library Computer Access and Retrieval System) panels of the Engineering station on the bridge of the Enterprise D allowed Chief Engineer Geordi La Forge (LeVar Burton) to monitor and control certain operations without needing to go down to Main Engineering. This lot consists of an acrylic panel with a black surface featuring orange, yellow, and purple graphics simulating numbered touch screen buttons with a globe-like diagram and the words "Engineering I." It exhibits some wear from use and age, including scratching in the acrylic. Dimensions: 28" x 45" x 0.25" (71.25 cm x 114.5 cm x 0.75 cm)

**Estimate: \$3,000 - 6,000**

45" (114.5 cm)





**1209**  
**Set of Seven**  
**Cast-Autographed Photos**  
**Star Trek: Various Productions**

A set of seven photos autographed by the cast of Gene Roddenberry's Star Trek. The photos depict the cast in the iconic maroon uniforms they famously wore in Star Trek II through Star Trek VI. This lot consists of seven color-printed photographs, each of a single character and autographed by their actor, including William Shatner, Leonard Nimoy, James Doohan, George Takei, Nichelle Nichols, Walter Koenig, and DeForest Kelley. Some of the photos exhibit minimal scratching to their glossy finish. Dimensions: (each) 8" x 10" (20.5 cm x 25.5 cm)

**Estimate: \$1,500 - 3,000**

**1210**  
**"Star Trek The Inventory"**  
**Production Binder Set**  
**Star Trek Franchise (1966-Present)**

"Star Trek The Inventory" production binder set from the Star Trek franchise. Production kept inventory logs of their props, models, make-up tests, and costumes for all their television series. This lot consists of five 3-ring binders. Each binder features a list of items that were placed within storage containers and photo images and copies, in color and black and white, within the binders that are labeled with the item name and its associated television series. This lot exhibits a sticky residue between the indexes from age. Dimensions: (largest) 11.5" x 11.5" x 4" (29.25 cm x 29.25 cm x 10.25 cm); (smallest) 10" x 11.5" x 1" (25.5 cm x 29.25 cm x 2.75 cm)

**Estimate: \$3,000 - 6,000**

**1211**  
**Set of Starfleet Insignia Badges**  
**Star Trek (2009)**

Four Starfleet Insignia badges from J. J. Abrams' sci-fi action film Star Trek. Starfleet Officers wore badges corresponding to their departments. This set consists of four arrowhead-shaped 3D-printed and metal-plated resin badges, one each from the Command, Science, Operations, and Medical departments. 3M double-stick tape is applied to the backs of three badges for affixing cleanly to uniforms. The set exhibits some scratching on the finish and discoloration. Dimensions (each): 4" x 2" x 0.25" (10.25 cm x 5.25 cm x 0.75 cm)

**Estimate: \$5,000 - 10,000**



**1212**  
**Set of Three Prop Reference Photo Books with Notes**  
**Star Trek: Deep Space Nine (1993-1999)**

Three prop reference photo books with notes from the production of sci-fi series Star Trek: Deep Space Nine. This lot consists of a blue binder labeled "DS9 Prop Pic Season 1-7" containing 184 photographs and 16 printed and four handwritten pages of prop department notes; a green binder labeled "DS9 Prop Pic 1-7 Seasons Book 2" containing 129 photographs and three printed and two handwritten note pages; and a blue album containing 242 photographs from various Star Trek series and 17 printed note pages. The notes exhibit crumpling throughout. Dimensions: (largest) 10" x 14" x 2" (25.5 cm x 35.75 cm x 5.25 cm)

**Estimate: \$4,000 - 8,000**

**1213**  
**Light-Up Medical Tricorder**  
**Star Trek (2009)**

A light-up medical tricorder from J.J. Abrams' 2009 sci-fi film Star Trek. A medical officer used her medical tricorder on Captain Christopher Pike (Bruce Greenwood) as he was helped aboard the Enterprise. This lot consists of a white medical tricorder that lights up with white light and remains lit when a button is pressed. Another button lights up the screen with a pale blue light but only while pressed. This tricorder takes three AAA batteries. It exhibits mild scratching and discoloration from production. Dimensions: 7.75" x 4" x 2" (19.75 cm x 10.25 cm x 5.25 cm) Contains electronics; see electronics notice in the Buyer's Guide.

**Estimate: \$3,000 - 6,000**



**1214**  
**Light-Up Replica Studio-Scale Refit**  
**U.S.S. Enterprise NCC-1701 Model**  
**Star Trek II: The Wrath Of Khan (1982)**

A light-up replica studio-scale model of the refit U.S.S. Enterprise NCC-1701 from Nicholas Meyer's sci-fi sequel Star Trek II: The Wrath of Khan. Created for Quantum Mechanix, this light-up 1:350 scale replica features a composite resin and fiberglass body over a steel endoskeletal frame; the vessel's distinctive Aztec hull plating pattern painted on through meticulous masking and airbrushing; applied ship lettering and graphics; and extensive lighting effects designed to include white LED interior lighting visible through the windows, blue LED warp-engine illumination, blinking formation and anti-collision lights, and lighting in the deflector dish, all of which are powered by a 12-volt power adapter and controlled through a three-function remote control. Internal details visible through the windows including the officers' lounge, botanical garden, recreation deck, and a shuttle bay visible by removing a cover piece on the stern of the starship. The model is displayed on an adjustable metal mount attached to a black wooden base with a gold-color metal plaque featuring the ship's information, a quote, and the logo for "The FX Company". The lot exhibits minimal wear from use and age. Dimensions: 36" x 17" x 18" (91.5 cm x 43.25 cm x 45.75 cm) Contains electronics; see electronics notice in the Buyer's Guide.

**Estimate: \$8,000 - 16,000**





**1215**  
**QMx Replica Studio-Scale USS Akira Model Prototype**  
**Star Trek: First Contact (1996)**

A studio-scale model prototype of the USS Akira from Jonathan Frakes' sci-fi action Star Trek: First Contact. It was made by Quantum Mechanix (QMx) as a proof-of-concept. This resin and polystyrene model is painted blue gray with various blue-gray shades of Aztec patterns; dark gray and antique gold-color painted facets to resemble metal; black paint fill for window slots; acrylic nacelle inlays; decals of the ship's name, registry, Starfleet pennants, and escape pods; mounted on a black acrylic base. This lot exhibits paint chipping with minor scratching and scuffing. Dimensions: (on display) 18" x 12" x 4.5" (45.75 cm x 31.75 cm x 11.5 cm)

**Estimate: \$2,500 - 5,000**



**1216**  
**History of Starflight Wright Flyer, Spirit of St. Louis,**  
**V-2 Rocket, and Ares V Rocket Models**  
**Star Trek Into Darkness (2013)**

History of Starflight Wright Flyer, Spirit of St. Louis, V-2 rocket, and Ares V rocket models from J. J. Abrams' sci-fi sequel Star Trek Into Darkness. Fourteen models depicting vessels representing major milestones in humanity's journey to the stars, from the Wright Flyer to the U.S.S. Vengeance, lined the office of Admiral Alexander Marcus (Peter Weller). Created by Quantum Mechanix's artisan prop and model shop, QMx FX Cinema Arts, these models are made of mixed media, including plastic and resin, with detailed lettering and graphics on the rockets and black strings in the wings of the Wright Flyer. All models include black bases with felt bottoms. The finish exhibits minimal scratching. Dimensions: (largest) 8" x 24.5" x 7" (20.5 cm x 61.75 cm x 18 cm)

**Estimate: \$4,000 - 8,000**



**1217**  
**History of Starflight Enterprise XCV-330,**  
**U.S.S. Kelvin, and U.S.S. Vengeance Models**  
**Star Trek Into Darkness (2013)**

History of Starflight Enterprise XCV-330, U.S.S. Kelvin, and U.S.S. Vengeance models from J. J. Abrams' sci-fi sequel Star Trek Into Darkness. Fourteen models depicting vessels representing major milestones in humanity's journey to the stars, from the Wright Flyer to the U.S.S. Vengeance, lined the office of Admiral Alexander Marcus (Peter Weller). Created by Quantum Mechanix's artisan prop and model shop, QMx FX Cinema Arts, these models are made of mixed media including resin and plastic, painted with intricate panel detailing and lettering (except for the Vengeance, which featured no hull lettering due to its secrecy). Each model includes a black base with a felt bottom. The Enterprise exhibits minimal paint chipping and the Kelvin exhibits decals peeling. Dimensions (largest): 18" x 11" x 10" (45.75 cm x 28 cm x 25.5 cm)

**Estimate: \$4,000 - 8,000**



**1218**  
**History of Starflight Phoenix, NX Alpha,**  
**and Enterprise NX-01 Models**  
**Star Trek Into Darkness (2013)**

History of Starflight Phoenix, NX Alpha, and Enterprise NX-01 models from J. J. Abrams' sci-fi sequel Star Trek Into Darkness. Fourteen models depicting vessels representing major milestones in humanity's journey to the stars, from the Wright Flyer to the U.S.S. Vengeance, lined the office of Admiral Alexander Marcus (Peter Weller). Created by Quantum Mechanix's artisan prop and model shop, QMx FX Cinema Arts, these models are made of mixed media, including resin and plastic, and painted with intricate hull detailing and lettering. Each model includes a black base with a felt bottom. They exhibit minimal scratching to the finish. Dimensions: (largest) 20" x 16" x 10" (51 cm x 40.75 cm x 25.5 cm)

**Estimate: \$4,000 - 8,000**



**1219**  
**History of Starflight Vostok, Gemini Capsule,**  
**North American X-15 Rocket Plane,**  
**and Space Shuttle Enterprise Models**  
**Star Trek Into Darkness (2013)**

History of Starflight Vostok, Gemini capsule, North American X-15 rocket plane, and Space Shuttle Enterprise models from J. J. Abrams' sci-fi sequel Star Trek Into Darkness. Fourteen models depicting vessels representing major milestones in humanity's journey to the stars, from the Wright Flyer to the U.S.S. Vengeance, lined the office of Admiral Alexander Marcus (Peter Weller). Created by Quantum Mechanix's artisan prop and model shop, QMx FX Cinema Arts, these models are made primarily of resin and plastic, painted with intricate hull detailing, lettering, and additional sculpted details on the Vostok including wiring, spherical tanks, and antennas. Each includes a black base with a felt bottom. They exhibit minimal scratching to the finish, and the Vostok's antennas are unattached. Dimensions: (largest) 18" x 13.5" x 9" (45.75 cm x 34.5 cm x 23 cm)

**Estimate: \$4,000 - 8,000**



**1220**  
**Lieutenant Uhura's (Zoe Saldana)**  
**Communications Earpiece**  
**Star Trek Into Darkness (2013)**

Lieutenant Uhura's (Zoe Saldana) communications earpiece from J. J. Abrams' sci-fi sequel Star Trek Into Darkness. Uhura wore her earpiece while serving as communications officer on the bridge of the Enterprise. This lot consists of a ribbed silver-color metal main body with a matching metal stem and a clear rubber ear insert. The rubber insert is unattached from the earpiece, and exhibits some yellowing and cracking. Dimensions: 2.5" x 0.75" x 0.75" (6.5 cm x 2 cm x 2 cm)

**Estimate: \$2,000 - 4,000**



**1221**  
**Women's "Where No Man Has Gone Before"**  
**Science-Division Tunic**  
**Star Trek: The Original Series (1966-1969)**

A women's science-division tunic from the second pilot of Gene Roddenberry's Star Trek: The Original Series. Starfleet officers wore tunics while on duty aboard the Enterprise. In the second pilot episode "Where No Man Has Gone Before," introducing William Shatner's Captain James T. Kirk, women's tunics featured gathered, folded-fabric necklines color-matched to the tunic, not the solid black ribbed plunging necklines featured in later conversions of women's tunics briefly used in early episodes, like "Charlie X." This version appears to be an incomplete conversion following later costuming revisions when the series was formally commissioned by NBC. This velour top was originally blue, indicating that it was worn by science officers, but turned mauve after repeated cleanings. A metal zipper runs up the back with the instruction "Iron Like Nylon, Avoid Hot Iron" printed alongside it inside. This lot exhibits split seams on the arms from the wrist up and both shoulders, and the collar has been reinforced with extra material but this has started to come away.

**Estimate: \$3,000 - 6,000**



**1222**  
**Hand-Painted Spock Costume Concept Artwork**  
**Star Trek: The Original Series (1966-1969)**

A hand-painted Spock costume concept artwork from the production of Gene Roddenberry's Star Trek: The Original Series. Pre-dating costume designer William Ware Theiss' involvement, Western Costume Company created various costume concepts, thus making this an early piece of Star Trek history. This lot consists of a full-bodied Spock stylized akin to Buck Rogers and Flash Gordon, in a brown uniform with ringed shoulder embellishments and a yellow and blue lightning bolt chest emblem; and is rendered in watercolor paint on illustration board, with handwritten notations and a small fabric swatch; and a paper wrapping for the piece with additional handwriting on it discussing the piece. The artwork is featured inside of a white double mat board with a brown inner edge. This lot exhibits wear from age, including yellowing, ripping, and staining. Dimensions: 16" x 20" x 0.25" (40.75 cm x 51 cm x 0.75 cm) Sold without copyright; see notice in the Buyer's Guide.

**Estimate: \$3,000 - 6,000**

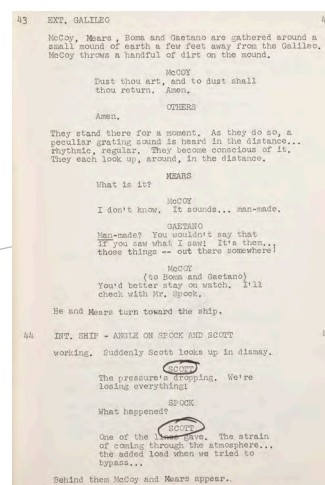

**1223**  
**James Doohan's Autographed Personal**  
**"The Galileo Seven" Final Draft Script with Call Sheet**  
**Star Trek: The Original Series (1966-1969)**

James Doohan's autographed personal final draft script with a call sheet from the Season 1 episode "The Galileo Seven" of Gene Roddenberry's Star Trek. The brass brad-bound, 66-page final draft script is autographed "Best Wishes" by Doohan in black marker and "Joan you didn't blind me at all" in gold-color marker, dated "September 15, 1966," and annotated throughout. The blue Desilu Productions call sheet is dated "9/29/1966 and hand-marked "James Doohan." The script exhibits a missing cover, and the call sheet's edges exhibit some yellowing and tearing from age. Dimensions: 8.5" x 11" x 0.5" (21.75 cm x 28 cm x 1.5 cm)

**Estimate: \$3,000 - 6,000**



**1224**  
**Set of 10 Vintage Season 1 Scripts**  
**Star Trek: The Original Series (1966-1969)**

10 vintage, brass brad-bound scripts from Season 1 of Gene Roddenberry's Star Trek. This set consists of original production scripts for the episodes "Arena," "Dagger of the Mind," "The Alternative Factor," and "The Return of the Archons," as well as late 1960s-to-early 1970s-era Lincoln Enterprises reproductions of scripts for "The Naked Time," "The Devil in the Dark," "Shore Leave," "The Conscience of the King," "Court Martial," and "This Side of Paradise." Seven scripts feature red Desilu Productions covers, two feature white covers, and one features a yellow cover, all of which are labeled "STAR TREK." Several scripts are hand-annotated. They exhibit creasing, edgewear, discoloration, and staining from use and age throughout. Dimensions: 8.5" x 11" x 5" (21.5 cm x 28 cm x 12.75 cm)

**Estimate: \$2,000 - 4,000**



**1226**  
**Vintage NBC Ephemera**  
**Star Trek: The Original Series (1966-1969)**

Vintage National Broadcasting Company (NBC) ephemera from Gene Roddenberry's sci-fi series Star Trek. This material was used to solicit support from affiliates and advertisers during the series' first-run. This assemblage of rare promotional items includes a 12-page Advance Information Programming brochure, a colorized three-fold Advance Information Programming brochure on Star Trek for foreign markets, a 6-page brochure advertising Season 2, a 16-page Season 2 "Mail Call" brochure sent to advertisers, 25 typewritten original NBC press releases from all three seasons, a rare black-and-white Enterprise cutout standee for NBC affiliate meetings, and other ephemeral paperworks including note-sized pages with form-letter responses to Star Trek's cancellation sent to impassioned fans. The lot exhibits discoloration, staining, creasing and edgewear, with further protection afforded through protective plastic sleeves. Dimensions: 8.5" x 11" x 0.5" (21.75 cm x 28 cm x 1.25 cm)

**Estimate: \$2,500 - 5,000**



**1225**  
**Robert Sabaroff's Autographed "The Immunity Syndrome"**  
**Scripts and Original Writer's Guide**  
**Star Trek: The Original Series (1966-1969)**

Robert Sabaroff's autographed "The Immunity Syndrome" scripts and original writer's guide from Gene Roddenberry's sci-fi series Star Trek. Sabaroff wrote the Season 2 episode depicting Enterprise's encounter with a threatening massive space-dwelling amoeboid about to spawn. This lot features two teleplay drafts, all brad-bound and signed on their front cover pages by Robert Sabaroff in 2000. A photocopied 62-page first draft features all-white pages. A gray-covered 66-page final draft script with multicolor pages features his father's "S. Sabaroff" hand-mark. The 31-page typewritten series writer's guide, issued to Sabaroff upon acquiring the writing assignment, is included. A notarized 11 December 2000 letter of authenticity signed by Robert Sabaroff is stapled to a printout of the original online auction listing. The lot exhibits minor creasing, edge wear, and staining. Dimensions: 8.5" x 11" x 1" (21.5 cm x 28 cm x 2.5 cm)

**Estimate: \$3,000 - 6,000**



**1227**  
**Cast- and Gene Roddenberry-Autographed Photo**  
**Star Trek: The Original Series (1966-1969)**

A photo autographed by Gene Roddenberry and the cast of Star Trek: The Original Series. The cast photo was taken for the promotion of the third and final season, and is one of the sets of photos that includes Majel Barrett, Roddenberry's future wife, with the Enterprise's primary crew. This lot consists of a color-printed photo of the main cast on the bridge of the Enterprise, and has been signed by Gene Roddenberry, Majel Barrett, William Shatner, Leonard Nimoy, James Doohan, George Takei, Nichelle Nichols, Walter Koenig, and DeForest Kelley. The photo's glossy finish exhibits a bit of light scratching. Dimensions: 8" x 10" (20.5 cm x 25.5 cm)

**Estimate: \$2,000 - 4,000**



**1228**  
Complete Set of 1967 Leaf Trading Cards with Box and Wrapper  
**Star Trek: The Original Series (1966-1969)**

A complete set of 1967 Leaf trading cards with a box and wrapper based on Gene Roddenberry's Star Trek: The Original Series. The very first trading card set based on the now-iconic sci-fi franchise, Leaf's Star Trek trading cards were released within a limited distribution area (Ohio and Illinois) and quickly recalled due to a licensing issue, making the cards extremely rare. This lot consists of a complete set of 72 black-and-white trading cards, one wax Leaf Star Trek gum wrapper, and an empty blue Leaf Star Trek bubblegum cardboard box. The wrapper exhibits minimal crinkling, and the box exhibits edge wear from age. Dimensions: (largest) 11" x 9.25" x 2" (28 cm x 23.5 cm x 5.25 cm)

**Estimate: \$2,500 - 5,000**



**1230**  
Complete Set of 1997-1998 Skybox Trading Cards and Paraphernalia  
**Star Trek: The Original Series (1966-1969)**

A complete set of 1997-1998 Skybox trading cards and paraphernalia based on Gene Roddenberry's Star Trek: The Original Series. In the late 1990s, Skybox released a number of different card sets based on various Star Trek series, including the Original Series. This lot consists of 104 sleeves of trading cards including all Seasons 1 - 3 common cards, all 85 autograph cards, 59 out of 62 autograph game cards (with three voided cards to complete the set), 80 Gold Plaque cards, all seven Season 2 mirror cards (only 200 of each were made), and Season 3 Captain's Card #28 of 1200. Also included are three wrappers, two collection posters, insert fliers including a checklist, and one empty Star Trek: The Original Series Season 1 card box. The box exhibits minimal edge wear from age. Dimensions: (largest) 9" x 11.25" x 5" (23 cm x 28.75 cm x 12.75 cm)

**Estimate: \$4,000 - 8,000**



**1229**  
Complete Set of 1976 Topps Bubble Gum Cards with Two Wrappers and One Full Box  
**Star Trek: The Original Series (1966-1969)**

A complete set of 1976 Topps bubble gum cards with two wrappers and one full box based on Gene Roddenberry's Star Trek: The Original Series. Topps, famous for its bubble gum cards, released cards based on the original Star Trek television series in 1976. This lot consists of a complete set of 88 cards with 22 stickers, two wax Star Trek wrappers, and a full Topps Star Trek bubble gum box containing 36 unopened packs. The wrappers and box exhibit edge wear from age. Dimensions: (largest) 5" x 7" x 2" (12.75 cm x 18 cm x 5.25 cm) The gum is no longer safe for consumption.

**Estimate: \$1,500 - 3,000**

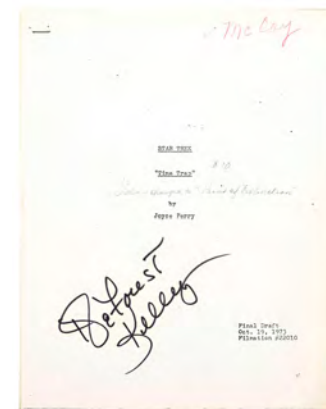

**1231**  
DeForest Kelley's Signed Personal "Time Trap" Final Draft Script  
**Star Trek: The Animated Series (1973-1974)**

DeForest Kelley's signed personal final draft script from the Season 1 episode "Time Trap" of the animated sci-fi series Star Trek: The Animated Series. Printed by production company Filmation, this stapled, 42-page final draft script is numbered "Filmation 22010," dated "Oct. 19, 1973," hand-marked "McCoy," and signed in black marker by Kelley on its title page. It is hand-marked "#10" and "Later changed to 'Point of Extinction,'" in graphite, referring to an unproduced episode title. The script exhibits staple holes, corner creasing, and edge wear throughout. Dimensions: 8.5" x 11" x 0.5" (21.75 cm x 28 cm x 1.5 cm)

**Estimate: \$1,200 - 2,400**



**1232**  
Light-Up Master Replicas Signature Edition 40th Anniversary Studio-Scale Enterprise Model  
**Star Trek: The Original Series (1966-1969)**

A light-up Master Replicas signature edition 40th anniversary studio-scale model of the Enterprise from Gene Roddenberry's classic sci-fi series Star Trek. The series followed the adventures of the starship Enterprise as its crew explored space, the final frontier. This injection-molded ABS plastic, 1/350th scale model lies over an internal metal armature painted like the screen-used model miniature, and features illuminated elements. Its display stand base is shaped like the command-division delta and features a power switch on the side. Included are a power adapter; a commemorative plaque numbered 116 of 250 and signed by principal actors Shatner, Nimoy, Takei, Nichols, and Koenig, with printed signatures of the late DeForest Kelley and James Doohan; a plaque stand; an information pamphlet; an instruction packet; two mail forms; an envelope; and its original shipping box. The box exhibits denting, taping, and remnants of multiple shipping labels. Dimensions: 33" x 15" x 14" (84 cm x 38.25 cm x 35.75 cm) Contains electronics; see notice in the Buyer's Guide.

**Estimate: \$4,000 - 8,000**



**1233**  
USS Enterprise NCC-1701-D Pyrotechnic Model Miniature Components  
**Star Trek: The Next Generation (1987-1994)**

USS Enterprise NCC-1701-D pyrotechnic model miniature components from the sci-fi series Star Trek: The Next Generation. In the Season 5 episode "Cause and Effect," the Enterprise repeatedly collided with the USS Bozeman while in a time loop. These ornately detailed components, ranging in size from small hull fragments, two nacelles split into four pieces, two bussard collector end caps, and the near-complete saucer with "NCC-1701-D" decals applied, are remains from the exploded pyrotechnic Enterprise model. Each is constructed from fiberglass and Bondo-like synthetic filler, hand-painted light blue and gray, and layered with tin sheets to produce an explosive effect. They exhibit intentional distressing with fractures, cracks, and rough edges by production to appear destroyed, and the decals are flaking off from age. Dimensions: (largest) 35" x 28" x 10" (89 cm x 71.25 cm x 25.5 cm)

**Estimate: \$4,000 - 8,000**

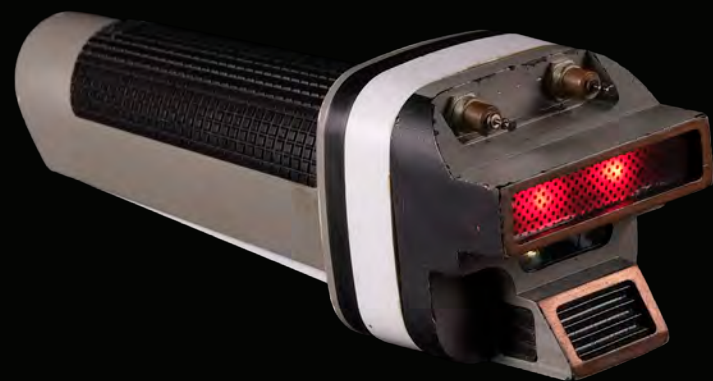

**1234**  
Lt. Cmdr. Data's (Brent Spiner) Cranial Cybernetic Tool  
**Star Trek: The Next Generation (1987-1994)**

Data's (Brent Spiner) cranial cybernetic tool featured in "Deja Q" from Gene Roddenberry's series Star Trek: The Next Generation. After Data saved a mortal Q's (John de Lancie) abduction by vengeful energy beings, Geordi LaForge (LeVar Burton) repaired him. This modified black-and-white plastic flashlight with a black rubber toggle is painted battleship gray. It features a custom-made black, gray, and copper-color painted resin adapter with a diffused red gel acrylic rectangular lens; two small bulbs behind blue plastic gel; two metal triplex-head nails emulating probes; and inset grills. It exhibits scratching, scuffing, chipping, discoloration, staining, and glue residue. Dimensions: 7" x 3" x 3" (17.75 cm x 7.75 cm x 7.75 cm) Contains electronics; see electronics notice in the Buyer's Guide.

**Estimate: \$2,000 - 4,000**



**1235**  
Ambassador Sarek's (Mark Lenard) Vulcan Ears  
**Star Trek: The Next Generation (1987-1994)**

Ambassador Sarek's (Mark Lenard) Vulcan ears from the sci-fi series Star Trek: The Next Generation. Sarek, the Vulcan father of Spock (Leonard Nimoy), appeared in the Season 3 episode "Sarek" and the Season 5 episode "Unification I." This lot consists of a pair of ear tip appliances. With a foam base covered in a layer of latex painted a flesh-tone, these ear tips feature a sculpted helix ridge and a pronounced antihelix. Also included is a Letter of Authenticity from artist Doug Drexler, who was working as a lead artist in the makeup department at that time and made the life cast of Mark Lenard himself. These ears exhibit discoloration and pitting in the foam, notable adhesive residue, and uneven paint coverage. Dimensions: (each) 3" x 2.25" x 1" (7.75 cm x 5.75 cm x 2.75 cm)

**Estimate: \$2,000 - 4,000**

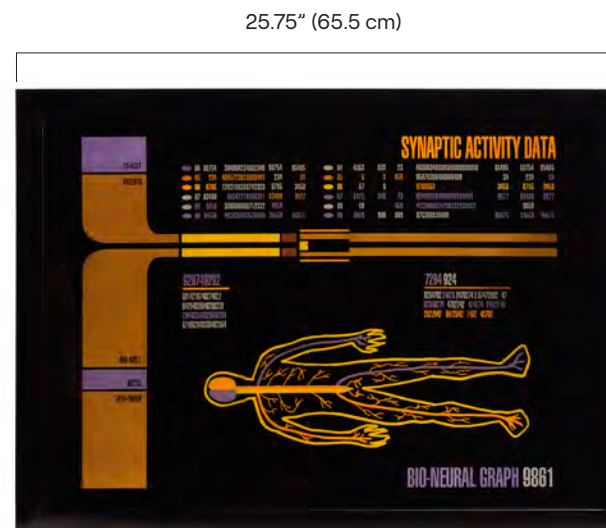

**1238**  
Framed Light-Up Medical LCARS Panel  
**Star Trek: The Next Generation (1987-1994)**

A framed light-up medical LCARS panel from the sci-fi television series Star Trek: The Next Generation. In Season 6's episode six, "True Q," Q (John de Lancie) and Amanda Rogers (Olivia d'Abo) discussed her situation in the medical lab. This light-up, custom-framed LCARS panel with an adapter is designed to appear illuminated when backlit. The black film panel features colored plastic gels adhered to the back and backed with white tissue paper acting as a light diffuser. The frame is topped with smoke-colored plexiglass. When illuminated, it shows "Synaptic Activity Data," "Bio-Neural Graph 9861" with a simulated yellow and purple body showing the circulatory system. It exhibits imperfections on the frame corners and mild scratching on the surface. Dimensions: 25.75" x 19" x 1" (65.5 cm x 48.25 cm x 2.5 cm) Contains electronics; see electronics notice in the Buyer's Guide.

**Estimate: \$2,000 - 4,000**

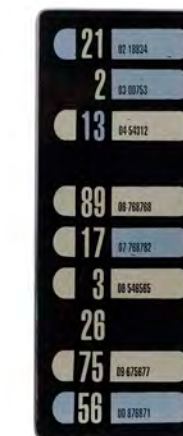

**1239**  
LCARS Door Panel  
**Star Trek: The Next Generation (1987-1994)**

A LCARS door panel from the sci-fi series Star Trek: The Next Generation. The starship Enterprise crew used keypad-like panels placed throughout the ship to access its computer system, with panels of this size often placed near doorways to open, lock, and request entrance. This lot consists of a black acrylic panel with light blue and cream-color graphics made to appear like numbered touch-screen buttons in the iconic LCARS (Library Computer Access and Retrieval System) style seen in Starfleet technology of the era. The acrylic exhibits scratching, including through some of the graphics. Dimensions: 3" x 7.5" x 0.25" (7.75 cm x 19.25 cm x 0.75 cm)

**Estimate: \$800 - 1,600**



**1236**  
Command Division  
Starfleet Uniform  
Costume  
**Star Trek: The Next  
Generation (1987-1994)**

A Command division Starfleet uniform costume from the sci-fi series Star Trek: The Next Generation. Updated Starfleet uniforms were worn from Season 3 onwards by high-ranking crew members of the USS Enterprise. This costume consists of a black and maroon wool tunic lined with black satin, black pants, and a pair of boots. The tunic features a raised collar with red piping, a rear zipper, a fastening strip on the chest for attaching a combadge, and two tags sewn onto the waistband hand-marked with "Koko RO4 46." The pants feature two fastening strips and a printed "Star Trek VII Irving Lewis" tag, suggesting use by LeVar Burton's stunt double in Star Trek: Generations. This costume exhibits discoloration on the pants, and scuffed boots.

**Estimate:  
\$2,000 - 4,000**



**1237**  
Guinan's (Whoopi  
Goldberg) Sleeves  
**Star Trek: The Next  
Generation (1987-1994)**

Guinan's (Whoopi Goldberg) sleeves from the sci-fi television series Star Trek: The Next Generation. Guinan was the bartender on the Enterprise, and offered sage advice to the crew. These sleeves have a shimmering, copper-color mesh, red trim, and a loop for the thumb. They are hand-labeled "Right" and "Left."

**Estimate: \$500 - 1,000**



**1240**  
Engineering Master Systems Display Table Console  
**Star Trek: The Next Generation (1987-1994)**

A main engineering master systems display table console from the sci-fi series Star Trek: The Next Generation. Geordi La Forge (LeVar Burton) and his team used the master systems display in Main Engineering to investigate Enterprise-D issues. This lot consists of one console with one intact LCARS screen made of gel sheets and white tissue paper with three attached black plexiglass plates. Composed of plastic and painted a beige color, this console features a mirrored design. This lot exhibits chipped paint, scratches, residual adhesive, and notable grime. Dimensions: 22" x 22.25" x 8.5" (51 cm x 56.5 cm x 21.6 cm)

**Estimate: \$1,500 - 3,000**



**1241**  
Geordi La Forge's (LeVar Burton)  
Lt. Commander Rank Pips  
**Star Trek: The Next Generation (1987-1994)**

Geordi La Forge's (LeVar Burton) Lt. Commander rank pips from the sci-fi television series Star Trek: The Next Generation. Chief Engineering Officer La Forge wore rank pips on the collar of his uniform to show his rank as Lieutenant Commander. The metal pips originated from the CBS/Paramount archives and exhibit some scuffing. Dimensions: 1.25" x 0.5" x 0.25" (3 cm x 1 cm x 0.75 cm)

**Estimate: \$800 - 1,600**



**1242**  
**Light-Up Computer**  
**Star Trek: The Next Generation (1987-1994)**

A light-up computer from the sci-fi series Star Trek: The Next Generation. Small silver-color computers were used throughout the series, appearing as Klingon computers in Season 5's "Redemption II" and "Unification II," and as a Federation computer in Season 6's "Descent." This lot consists of an acrylic computer painted silver-color with a black acrylic screen, a small black rubber ribbed embellishment on the front, and black decals throughout. A blue button on the base makes two small green lights blink, powered by a 9V battery. It exhibits some scratching to the acrylic and the bottom panel is loose. Dimensions: 11.5" x 8.5" x 10.5" (29.25 cm x 21.75 cm x 26.75 cm) Contains electronics; see electronics notice in the Buyer's Guide.

**Estimate: \$3,000 - 6,000**



**1243**  
**Pair of Science and Operations Divisions**  
**23rd Century Starfleet Uniform Tunics**  
**Star Trek: Deep Space Nine (1993-1999)**

A pair of Science and Operations divisions 23rd Century Starfleet uniform tunics from the sci-fi television series Star Trek: Deep Space Nine. In the Season 5 episode "Trials and Tribble-ations," the Deep Space 9 crew wore 23rd Century uniforms to blend in amongst the crew of the Enterprise when they traveled back in time to the 2200s. This lot consists of two Spandex-blend tunics, one in blue with a gold-color Science division assignment patch and one in red with a gold-color Operations division assignment patch, both with hidden shoulder-seam zippers. The tunics exhibit minimal signs of wear from production, including loose threads in the collars.

**Estimate: \$4,000 - 8,000**

**1244**  
**Romulan Disruptor Rifle**  
**Star Trek: Deep Space Nine (1993-1999)**

A Romulan disruptor rifle from the sci-fi series Star Trek: Deep Space Nine. Romulan soldiers carried their signature rifles throughout the series, including when Enabran Tain's (Paul Dooley) men took Elim Garak (Andrew J. Robinson) and Odo (Rene Auberjonois) hostage in the Season 3 episode "Improbable Cause." This otherworldly resin rifle is painted metallic gray with a matte black textured grip, static blue paneling, and copper-color detailing on the body and barrel. It exhibits adhesive residue on the left side and various minor chips to the paint from production use, exposing the resin throughout. Dimensions: 19" x 9" x 3" (48.25 cm x 23 cm x 7.75 cm)

**Estimate: \$3,000 - 6,000**



**1245**  
**Light-Up Bajoran Tricorder**  
**Star Trek: Deep Space Nine (1993-1999)**

A light-up Bajoran tricorder from Rick Berman and Michael Piller's sci-fi series Star Trek: Deep Space Nine. Major Kira Nerys (Nana Visitor) used a Bajoran tricorder in her search for survivors of a crashed Cardassian prison transport in Season 4's episode "Indiscretion." The resin hollow-cast tricorder features burgundy, red, gold, and bronze-color paint to resemble metal; black painted side and bottom grips; and small red and green acrylic button insets. A round black button powers a backlit acrylic translite to emulate a digital read-out and insets. The underside features a removable plate to access electronics and battery via six Phillips-head screws. Exhibits chipping, scratching, scuffing, pitting, and a missing screw. Dimensions: 6" x 3.5" x 2" (15.25 cm x 9 cm x 5 cm) Contains electronics; see electronics notice in the Buyer's Guide.

**Estimate: \$3,000 - 6,000**



**1246**  
**Stunt One-Piece TR-590 Mark IX**  
**Tricorder Molded in Holster**  
**Star Trek: Deep Space Nine (1993-1999)/Star Trek: Voyager (1995-2001)**

A stunt one-piece TR-590 Mark IX tricorder molded in holster from the Star Trek series Deep Space Nine and Voyager. The Mark IX generation of tricorder was used by Starfleet for various diagnostic purposes throughout both series, and was first introduced in Star Trek: First Contact. This stunt tricorder is constructed from rubber molded and painted to appear concealed inside a textured black leather holster. It features multicolor decals applied on the front and bottom and rubber-tipped metal clips for securing to a costume on the reverse. A Letter of Authenticity from franchise propmaker Michael Moore is included. The rubber exhibits visible cracking throughout from age and production use. Dimensions: 3.5" x 4.25" x 1.5" (9 cm x 11 cm x 4 cm)

**Estimate: \$2,500 - 5,000**



**1247**  
**Set of Gold-Pressed Latinum**  
**Star Trek: Deep Space Nine (1993-1999)**

A set of gold-pressed latinum from Rick Berman and Michael Piller's sci-fi series Star Trek: Deep Space Nine. Gold-pressed latinum was the favored currency of the Ferengi, and consisted of a rare liquid metal element encased in "worthless" gold. This assortment consists of five pieces, exemplifying the different denominations used in the series: a slip, a strip, two bars of different sizes, and a brick. Each set is painted varying shades of gold-color and cast in resin, with unique engravings in the center. They exhibit minimal scuffs, scratching, chipping, pitting and edge wear. Dimensions: (packaged) 8" x 4" x 4" (20.5 cm x 10.25 cm x 10.25 cm)

**Estimate: \$2,000 - 4,000**



**1248**  
 USS Defiant Door Panel  
**Star Trek: Deep Space Nine**  
 (1993-1999)

A USS Defiant door panel from the sci-fi series Star Trek: Deep Space Nine. The crew aboard the prototype vessel Defiant, as well as its replacement of the same name, used door panels to open, lock, and request entrance to doors throughout the ship. This lot consists of a black acrylic rectangular panel with numbered yellow button graphics and a purple Starfleet logo graphic. It exhibits scuffing and scratching from use and age, including some through the buttons. Dimensions: 1.75" x 5.25" x 0.25" (4.5 cm x 13.5 cm x 0.75 cm)

**Estimate: \$800 - 1,600**

**1249**  
 One-Piece Type II Phaser  
 Molded in Holster  
**Star Trek: Voyager (1995-2001)**

A one-piece Type II phaser molded in holster from the sci-fi series Star Trek: Voyager. Type II phasers were standard-issue weapons for Starfleet crew and were seen in various episodes of the series. This lot consists of the one-piece static phaser molded into its holster. The phaser portion is made of resin with a handle that features black ridges on the bottom. Painted a silver-color, the phaser has three buttons on the back. The holster is painted black to emulate textured plastic. This lot exhibits discoloration, scratching, and chipped and flaked paint. Dimensions: 8" x 3" x 2" (20.5 cm x 7.75 cm x 5.25 cm)

**Estimate: \$3,000 - 6,000**

**1250**  
 Holodeck Eryops Model  
**Star Trek: Voyager (1995-2001)**

A holodeck Eryops model from the sci-fi series Star Trek: Voyager. In the Season 3 episode "Distant Origin," Captain Kathryn Janeway (Kate Mulgrew) and the Doctor (Robert Picardo) used holodeck models of Earth's earliest lifeforms, including the Eryops, to try to trace the evolutionary path of the reptilian Voth. This model was sculpted in clay by creature effects artist Jordu Schell and painted green with yellow eyes by visual effects producer Dan Curry. It features a black foam, wood, and blue fabric base with a placard featuring information about the episode, model, and its creators. The model exhibits cracking throughout, most notably in the legs and toes. Dimensions: 24" x 13.5" x 7.5" (61 cm x 34.5 cm x 19.25 cm)

**Estimate: \$3,000 - 6,000**



**1251**  
 Stunt One-Piece Type 2  
 "Boomerang" Phaser  
 Molded in Holster  
**Star Trek:  
 Voyager (1995-2001)**

A stunt one-piece Type 2 "Boomerang"-style phaser molded in holster from the sci-fi series Star Trek: Voyager. Starfleet officers used curved "boomerang"-style phasers throughout the Star Trek franchise, beginning with Star Trek: First Contact. This stunt phaser is constructed from soft foam rubber molded and painted to appear concealed inside a textured black leather holster. It features three static buttons on top painted white and silver-color to match the body and a fastening strip for securing to a costume glued onto the bottom. The phaser exhibits visible cracking and adhesive residue from production. Dimensions: 8" x 2" x 2" (20.5 cm x 5 cm x 5 cm)

**Estimate:  
 \$2,500 - 5,000**

**1253**  
 Light-Up Alien  
 Scanning Device  
**Star Trek:  
 Voyager (1995-2001)**

A light-up alien scanning device from the sci-fi series Star Trek: Voyager. The starship Voyager crew encountered different alien species during its journey through the Delta Quadrant. This lot consists of a cast resin textured handle painted black with a copper-color circle on the bottom and metal embellishments. Frontal lights are powered by two N-size 1.5 volt batteries inserted beneath a battery cover. It exhibits scuffing to the painted finish from use and age, and current electronic functionality remains untested. Dimensions: 7" x 4.75" x 2" (18 cm x 12.25 cm x 5.25 cm) Contains electronics; see electronics notice in the Buyer's Guide.

**Estimate:  
 \$1,000 - 2,000**



**1252**  
 B'Elanna Torres (Roxann  
 Dawson) Distressed  
 Operations-Division  
 Starfleet Uniform  
 Costume  
**Star Trek:  
 Voyager (1995-2001)**

B'Elanna Torres (Roxann Dawson) distressed Operations division Starfleet uniform costume from the sci-fi series Star Trek: Voyager. Torres wore her uniform throughout the series. This costume consists of a black and gold-color cotton-blend jumpsuit that includes a triangle patch of hook-and-loop fastener for a combadge, and a waistband with compartments to hold phasers and other devices. This jumpsuit also features a hand-marked tag for "C Roxann Dawson." Production intentionally distressed the jumpsuit to give it the appearance of grime and frayed fabric. It exhibits mild broken seam threads.

**Estimate:  
 \$2,000 - 4,000**



**1254**  
 Daelen's Jumpsuit  
 and Belt  
**Star Trek:  
 Voyager (1995-2001)**

Daelen's jumpsuit and belt from the sci-fi series Star Trek: Voyager. Steth (Dan Butler), the Imposter, shifted back into Daelen's (Mary Elizabeth Mc Glynn) form wearing his jumpsuit throughout the season four episode, "Vis à Vis." This costume consists of a maroon cotton-blend, long-sleeve jumpsuit with a front zip-closure, a cream-colored cotton-blend dickie, and maroon leather belt with a hook-and-loop fastener at the back. They are hand-marked with "Sandra Rascon" on the tags, and the dickie features a second tag with "Rob McNeill" hand-written on it. This costume exhibits fabric fraying on the seam edges of the dickie, the belt exhibits puckering, and separation on the underside.

**Estimate: \$800 - 1,600**



**1255**  
**Light-Up QMx Replica Studio-Scale**  
**Enterprise NX-01 Promotional Model**  
**Star Trek: Enterprise (2001-2005)**

A light-up QMx replica studio-scale promotional model of the Enterprise NX-01 from the sci-fi series Star Trek: Enterprise. Captain Jonathan Archer (Scott Bakula) and his crew forged alliances and engaged in missions aboard Enterprise. This lot consists of the 1:350 scale model Quantum Mechanix (QMx) convention display and sales page photography model constructed of polystyrene, acrylic, and polyresin. It features a metallic enamel painted exterior. 150 LED lights emulate functioning engines, formation signals, and windows; backed by sound features for phasers and torpedoes, controlled via a keyless fob attached to a clear acrylic "Starfleet" logo. The miniature mounts via metal pole to an MDF base featuring two aluminum Starfleet logo plaques, one unsigned, the other featuring "QMx FX Cinema Arts" and "O of 100." An egg crate-padded wood shipping crate is included. The lot exhibits scuffing, scratching, and edge wear. Dimensions: (on base) 28" x 18" x 9" (71.25 x 45.75 cm x 23 cm) Contains electronics; see electronics notice in the Buyer's Guide.

**Estimate: \$6,000 - 12,000**



**1258**  
**Chateau Picard Bourgogne Wine Crate and Bottle**  
**Star Trek: Picard (2020-2023)**

A Chateau Picard Bourgogne wine crate and bottle from Paramount Plus' hit series Star Trek: Picard. In the Season 2 episode "The Star Gazer," Jean-Luc Picard's (Patrick Stewart) Romulan housekeeper Laris (Orla Brady) supervised the boxing and labeling of bottles of Chateau Picard Bourgogne. This lot consists of one packing straw-filled wooden crate with a removable cover engraved "Appellation Labarre Controle Chateau Picard Bourgogne Franche-Comte" and dated "2386," as well as a black wax-sealed bottle filled with red wine-color liquid and wrapped with a faux silver label with engravings matching the cover. The liquid is not safe for consumption, and the lot exhibits some missing straw. Dimensions: (boxed) 21.25" x 14" x 7.25" (54 cm x 35.75 cm x 18.5 cm)

**Estimate: \$2,500 - 5,000**



**1259**  
**Raffi Musiker's (Michelle Hurd)**  
**Confederation Combadge**  
**Star Trek: Picard (2020-2023)**

Raffi Musiker's (Michelle Hurd) Confederation combadge from the sci-fi series Star Trek: Picard. In the Season 2 episode "Penance," Raffi wore her combadge in an alternate timeline where she was a Confederation security chief fighting the rebels. Designed by property master Jeffrey Lombardi, this metal combadge features curved edges and a red and silver-color rank column at center. It exhibits scuffs and scratching from production wear.

**Estimate: \$2,000 - 4,000**



**1256**  
**Travis Mayweather's (Anthony Montgomery)**  
**Starfleet Costume**  
**Star Trek: Enterprise (2001-2005)**

Travis Mayweather's (Anthony Montgomery) Starfleet costume from the series Star Trek: Enterprise. Ensign Mayweather wore his standard-issue Starfleet uniform throughout the series. This blue jean Starfleet jumpsuit features gold-color trim around the shoulders and a Starfleet patch sewn on the left arm. The jumpsuit features zippered pockets and a front zipper extending from the collar to the waist. The arm and leg cuffs feature a zipper and fastening strip flap. The jumpsuit also features an Enterprise tag hand-marked with "Anthony Montgomery 3rd. Season 1" and "Anthony L," along with an unmarked production tag. This costume exhibits bleach discoloration on the back.

**Estimate: \$2,500 - 5,000**



**1260**  
**Frankie Banali's "Force Field"**  
**Framed Art Print from Chateau Picard Library**  
**Star Trek: Picard (2020-2023)**

Frankie Banali's "Force Field" framed art print from Chateau Picard's Library from the sci-fi drama Star Trek: Picard. The late Banali, drummer for the heavy metal band Quiet Riot, created abstract paintings. Featured within Chateau Picard's library bookshelves, this framed painting is printed on archival paper and enclosed in a metal-sheathed wood frame. Hand-numbered "4/25," it features the artist's signature and initials, plus a red stamp. The frame back features a hanging wire, is hand-marked with "61" in black marker on white backing board, with "Library" hand-marked on blue painter's tape affixed to the back. It exhibits minor edgewear on the frame from on-set use. Dimensions: 23" x 35" x 1.5" (58.5 cm x 89 cm x 4 cm) All proceeds from this lot benefit the Pancreatic Cancer Foundation.

**Estimate: \$1,500 - 3,000**



**1261**  
**John Duncan Collection: Detonated Naboo N-1**  
**Starfighter Model Miniature Pieces**  
**Star Wars: Episode I - The Phantom Menace (1999)**

Detonated Naboo N-1 starfighter model miniature pieces from George Lucas' Star Wars: The Phantom Menace. The N-1 was the high-speed, single-pilot fighter used by Naboo's forces in space combat. This set comes from the collection of concept model maker John Duncan. It consists of five cast resin model miniature components: two engine nose cones; an R2-D2 head; a foam-filled engine spike; and an exploded pyrotechnics model fragment. The fragment is painted yellow on one side and gray on the other. They exhibit chipped paint, notable seams from the curing process, and mild discoloration from production. Dimensions: 14" x 7" x 3" (35.5 cm x 18 cm x 7.75 cm)

**Estimate: \$2,000 - 4,000**



**1257**  
**USS Defiant Chair from "In a Mirror, Darkly, Part II"**  
**Star Trek: Enterprise (2001-2005)**

A USS Defiant chair from the Season 4 episode "In a Mirror, Darkly, Part II" of the sci-fi drama series Star Trek: Enterprise. Terran Empire's Jonathan Archer (Scott Bakula) seized command of a Tholian-captured Defiant. This modified Burke-style tulip chair features gray blue paint over sky blue paint suggesting previous usage; a custom black leather foam-padded back topper; a black foam-padded seat cushion; three flat triangle plant-ons at the lower back; and a black painted metal X-shaped swivel base. A worn "Lot No. 186179 Piece No. 038" sticker is affixed to a leg. It exhibits scratching, paint chipping, scuffing, and rips and creases in the leather from age and conveyance. Dimensions: 22" x 18" x 41" (56 cm x 45.75 cm x 104.25 cm) Special shipping required; see notice in the Buyer's Guide.

**Estimate: \$2,000 - 4,000**





**1262**  
 Production-Made Qui-Gon Jinn  
 (Liam Neeson) Lightsaber Hilt  
**Star Wars: Episode I - The Phantom Menace (1999)**

A Qui-Gon Jinn (Liam Neeson) lightsaber hilt from the production of George Lucas' Star Wars: The Phantom Menace. Jedi Master Jinn used his signature lightsaber throughout the film, including in his fateful duel with Darth Maul (Ray Park). This lightsaber is made of cast resin with a white glossy finish and sculpted details throughout. It exhibits some wear from handling and age, including cracking, chipping, and a small purple mark. Dimensions: 11.5" x 2" x 2" (29.25 cm x 5.25 cm x 5.25 cm)

**Estimate: \$2,000 - 4,000**



**1264**  
 Nick Gillard Collection: Issue "001" Script  
**Star Wars: Episode II - Attack Of The Clones (2002)**

An issue "001" script from the production of George Lucas' Star Wars: Episode II - Attack of the Clones that comes from the collection of stunt coordinator and sword master Nick Gillard. The 110-page script is brass brad-bound between blue card covers, with Gillard's name handwritten on the front. The title page features "JAK 001," the working title "Jar Jar's Great Adventure," and Gillard's name handwritten inside a red "No Unauthorized Distribution" stamp. Included are 11 paperclipped amendment pages and a cover page. This is a very rare untouched iteration of the script, before any amendments and changes. Those changes usually resulted in the original pagers being shredded. It exhibits crease lines in the card cover and paper clip rust marks. Dimensions: 11.75" x 8.25" x 0.75" (30 cm x 21 cm x 2 cm)

**Estimate: \$2,000 - 4,000**

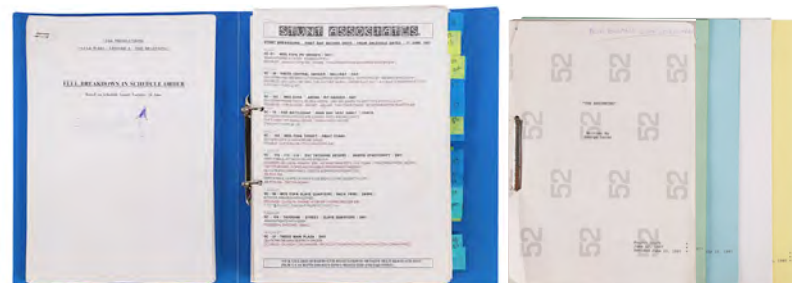

**1263**  
 Nick Gillard Collection Ephemera  
**Star Wars: Episode I - The Phantom Menace (1999)**

Ephemera from George Lucas' Star Wars: The Phantom Menace. This lot comes from the collection of celebrated stunt coordinator and sword master Nick Gillard. The lot consists of an 82-page filming schedule breakdown; a 119-page fourth draft script; four sets of revision pages printed on multicolored paper, and a blue binder labeled "Lovely Stunts" containing stunt breakdowns and a third draft script. Each script page is watermarked with issue number "52" and both documents feature the film's working title "The Beginning." The set exhibits minor tears, metal script clip corrosion, and minor marks. Dimensions: (binder) 12.25" x 10" x 1.5" (31 cm x 25.5 cm x 3.5 cm)

**Estimate: \$1,000 - 2,000**



**1265**  
 Nick Gillard Collection: FX Live Action Reshoot Binder  
**Star Wars: Episode III - Revenge Of The Sith (2005)**

A special effects (FX) live action reshoot binder from the production of George Lucas' Star Wars: Episode III - Revenge of the Sith. This lot comes from the personal collection of celebrated stunt coordinator and sword master Nick Gillard. The gray binder holds 369 pages detailing all the FX live action reshoots needed throughout the film. Most pages feature an image of the FX shot, a short printed description, names of the characters, and their lines, if any. It includes a few handwritten annotations and sticky notes throughout the letter pages. The pages exhibit minor creasing and marks from handling. Dimensions: 13.75" x 11.5" x 3.25" (35 cm x 29 cm x 8 cm)

**Estimate: \$800 - 1,600**

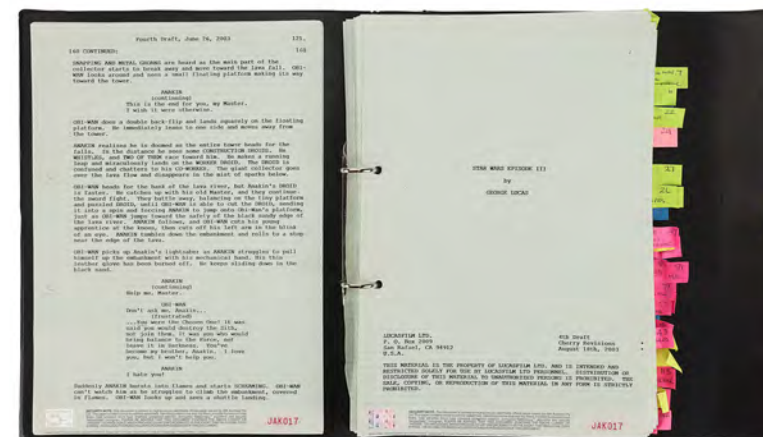

**1266**  
 Nick Gillard Collection: Personal Shooting Script  
**Star Wars: Episode III - Revenge Of The Sith (2005)**

Nick Gillard's personal shooting script from the production of George Lucas' Star Wars: Episode III - Revenge of the Sith. This lot comes from the collection of stunt coordinator and sword master Nick Gillard. This 130-page, fourth draft script is housed in a black plastic ring binder with Gillard's name handwritten in white pen. It features numerous sticky notes with handwritten annotations, and the page displays issue number "JAK 017." Included are 10 alternate revision pages in a separate plastic wallet. The script exhibits minor creasing and a few tears near the hole punches. Dimensions: (binder) 12.25" x 10.25" x 1.75" (31cm x 26 cm x 4.5 cm)

**Estimate: \$1,000 - 2,000**



**1267**  
 John Duncan Collection: Production-Made Kachirho  
 Command Center Support Strut Model Miniature  
**Star Wars: Episode III - Revenge Of The Sith (2005)**

A production-made Kachirho Command Center support strut model miniature from George Lucas' Star Wars: Revenge of the Sith. Yoda (Frank Oz) oversaw Kachirho's defense from its command center when Emperor Palpatine (Ian McDiarmid) wiped out the Jedi and established the Galactic Empire. This miniature comes from the collection of concept model maker John Duncan. Assembled from backup pieces manufactured during the larger model's construction, it is made of machined aluminum and laser-cut steel painted black, gray, copper and gold with CNC-finished teak wood in the Wookiee aesthetic. It exhibits minor edge wear and paint chipping. Dimensions: 18" x 2" x 9" (45.75 cm x 5.25 cm x 23 cm)

**Estimate: \$1,500 - 3,000**



**1268**  
 Production-Made Mace Windu  
 (Samuel L. Jackson) Lightsaber Hilt  
**Star Wars: Prequel Trilogy (1999-2005)**

A Mace Windu (Samuel L. Jackson) lightsaber hilt from the production of George Lucas' Star Wars prequel trilogy. Jedi Master Windu wielded his signature lightsaber throughout the series, including when he dueled with Jango Fett (Temuera Morrison) on Kamino. This lightsaber is made of cast resin with a white glossy finish and sculpted details throughout. This lightsaber also features an intricately patterned texture engraved into select areas of the handle. It exhibits some wear from handling and age, including cracking and chipping. Dimensions: 10.5" x 2" x 2" (26.75 cm x 5.25 cm x 5.25 cm)

**Estimate: \$2,000 - 4,000**



**1269**  
 Rebel Trooper Ceremonial  
 Uniform Costume  
**Star Wars:**  
**Episode IV - A New Hope (1977)**

A Rebel Trooper ceremonial uniform costume from George Lucas' Star Wars: A New Hope. Rebel Troopers gathered in the Great Temple on Yavin 4 to honor and reward Luke Skywalker (Mark Hamill), Han Solo (Harrison Ford), and Chewbacca (Peter Mayhew) in their success of destroying the Death Star. This uniform consists of a dark green polyester jacket labeled "40c 5'10 792" and "Harry Daly Tom Keane" and a pair of matching trousers labeled "32 W 32L 747" and "747." Included is a loose tag from Angels and Bermans marked "1993 32" L." This lot exhibits fraying and loose threads.

**Estimate: \$3,000 - 6,000**



**1270**  
 Production-Made Tantive IV  
 Corridor Wall Panel  
**Star Wars:**  
**Episode IV - A New Hope (1977)**

A production-made Tantive IV corridor wall panel from George Lucas' Star Wars: A New Hope. Panels lined the interior walls of Princess Leia's (Carrie Fisher) Tantive IV corvette starship in the film's opening sequence. This gray, vacuum-formed plastic panel features two large raised circular emblems, three medium-sized raised circles in its center, four small protruding circles adorning each corner, and one small raised rectangle. The panel exhibits tape and adhesive residue on the back and cracking along the edges and in one of the large circles. Dimensions: 9" x 18" x 1.5" (23 cm x 45.75 cm x 4 cm)

**Estimate: \$1,000 - 2,000**

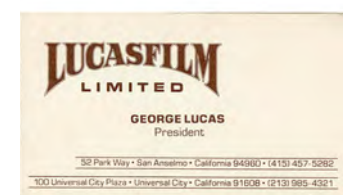

**1271**  
 George Lucas' Business Card and  
 Subsidiary Letterheads  
**Lucasfilm**

George Lucas' business card and subsidiary letterheads from Lucasfilm Ltd. This lot consists of George Lucas' Lucasfilm Limited business card on cardstock; one Star Wars Revenge of the Jedi subsidiary; one Star Wars The Empire Strikes Back subsidiary; one Radio Pictures Inc. subsidiary; one Raiders of The Lost Ark subsidiary; one Industrial Light & Magic (ILM) subsidiary; one Black Falcon Ltd. subsidiary; and two Star Wars subsidiaries. This lot exhibits minor discoloration from age. Dimensions: (card) 3.5" x 2" (9 cm x 5 cm); (subsidiary) 8.5" x 11" (21.75 cm x 28 cm)

**Estimate: \$800 - 1,600**



**1272**  
 Kit Kat-Style High-Altitude Death  
 Star Surface Model Miniature Panel  
**Star Wars:**  
**Episode IV - A New Hope (1977)**

A high-altitude Death Star surface model miniature panel from George Lucas' Star Wars: A New Hope. This kit kat-style panel, so known for its distinctive shape, was designed and constructed by Industrial Light & Magic (ILM) as part of the vast miniature Death Star set, specifically for shots where Rebel fighters flew high above its massive surface. This biscuit foam panel is decorated with cast greeblies and finished in industrial gray paint. Its paint has discolored from age and its underside features a splotch of paint from production. Dimensions: 3" x 3" x 1.25" (7.75 cm x 7.75 cm x 3 cm)

**Estimate: \$2,000 - 4,000**



**1273**  
 Dave Jones Collection: Death  
 Star Surface Model Miniature  
 Component  
**Star Wars:**  
**Episode IV - A New Hope (1977)**

A Death Star surface model miniature component from Star Wars: A New Hope. Panels of this style were made in several different patterns, cast in bulk, then painted by hand and assembled to create the overall surface of the Death Star. This dense foam panel comes from the collection of veteran model maker Dave Jones. Designed and constructed by Industrial Light & Magic's (ILM) model miniature department, it is hand-painted gray and carved in a grid-like pattern to simulate paneled construction. This lot exhibits chipped paint and a buildup of grime. Dimensions: 3" x 3" x 0.75" (7.75 cm x 7.75 cm x 2 cm)

**Estimate: \$1,500 - 3,000**

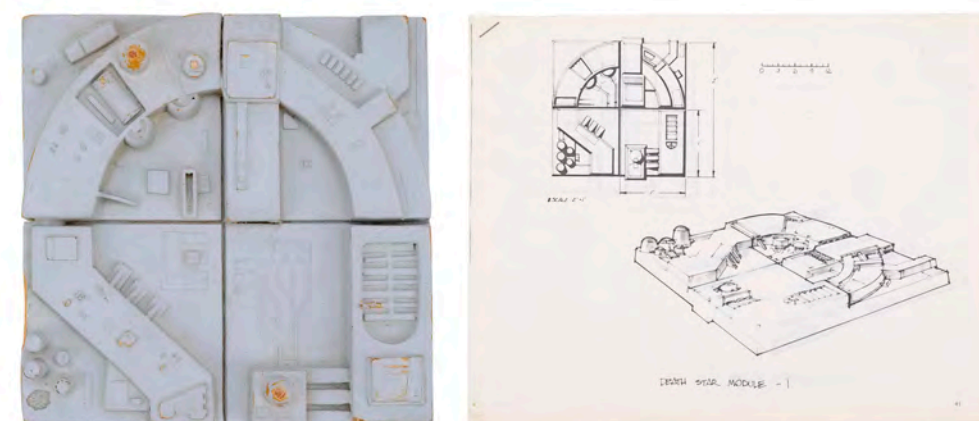

**1274**  
 Low Altitude Death Star Surface  
 Model Miniature with Printed  
 Design Reference Packet  
**Star Wars:**  
**Original Trilogy (1977-1983)**

A low altitude Death Star surface model miniature from George Lucas' Star Wars: A New Hope with a printed design reference packet. This panel was designed and constructed by Industrial Light & Magic (ILM) as part of the vast miniature Death Star set for shots where Rebel fighters flew close to its massive surface. This lot consists of a biscuit foam panel decorated with cast greeblies and finished in industrial gray paint, as well as a stapled five-page packet of printed design illustrations labeled "Death Star Module." The panel exhibits brown stains on the top. Dimensions: 6" x 6" x 1" (15.25 cm x 15.25 cm x 2.5 cm)

**Estimate: \$3,000 - 6,000**



**1275**  
 Dave Jones Collection:  
 Imperial TIE Fighter Pyro Model Miniature Wing Strut  
**Star Wars: Episode IV - A New Hope (1977)**

An Imperial TIE fighter pyro model miniature wing component from the production of George Lucas' Star Wars: A New Hope. TIE fighters were the standard combat ships of the Galactic Empire. This wing strut, an incomplete section of a TIE fighter's solar array support frame, comes from the collection of veteran model maker Dave Jones. Designed and constructed by Industrial Light & Magic's (ILM) miniature department for SFX shots of TIE fighters being shot down by Rebel fighters, it is cast from epoxy resin with detailed greebles and an industrial black paint finish. Its base exhibits fracturing and discoloration from being exploded during production, and it exhibits a hole at top. Dimensions: 9.5" x 2.5" x 0.5" (24.25 cm x 6.5 cm x 1.25 cm)

**Estimate: \$1,000 - 2,000**



**1277**  
 Alderaan Rock Debris  
**Star Wars: Episode IV - A New Hope (1977)**

A piece of Alderaan rock debris from George Lucas' Star Wars: A New Hope. When the Millennium Falcon arrived at the coordinates of Alderaan, Luke Skywalker (Mark Hamill) and his companions found nothing but debris because the planet was destroyed by the Death Star. This lot consists of one piece of debris, made out of foam and painted gray to simulate stone with a rough textured surface covered in bumps and craters. It exhibits some minor chipping to the painted finish. Dimensions: 4" x 5" x 5" (10.25 cm x 12.75 cm x 12.75 cm)

**Estimate: \$2,500 - 5,000**



**1276**  
 Dave Jones Collection:  
 Production-Made R2-D2 Model Miniature  
**Star Wars: Episode IV - A New Hope (1977)**

An R2-D2 model miniature from the production of George Lucas' Star Wars: A New Hope. R2 (Kenny Baker) aided Luke Skywalker (Mark Hamill) in his assault on the Death Star from the back of his X-wing. This lot comes from the collection of veteran model maker Dave Jones. Created by Industrial Light & Magic's (ILM) miniatures team but ultimately unfinished, this static resin model of R2's upper body is ornately cast with his signature greebles and panels. The resin exhibits fractures throughout and exhibits discoloration from age. Dimensions: 1" x 1" x 1.5" (2.5 cm x 2.5 cm x 3.75 cm)

**Estimate: \$1,000 - 2,000**



**1278**  
 Dave Jones Collection: Production-Made Imperial TIE  
 Fighter Model Miniature Components  
**Star Wars: Episode IV - A New Hope (1977)**

Imperial TIE fighter model miniature components from the production of George Lucas' Star Wars: A New Hope. Imperial TIE fighters were the standard combat ships of the Galactic Empire. This set of unfinished resin components cast by Industrial Light & Magic's (ILM) miniatures team for the TIE models comes from the collection of veteran model maker Dave Jones. It consists of two bottom hatch sections painted black and silver, an unpainted wing collar, and a gray blaster light with its bulb painted orange. The set exhibits paint flaking throughout, and the hatch sections are scratched from production. Dimensions: (largest) 3" x 3" x 1" (7.75 cm x 7.75 cm x 2.5 cm)

**Estimate: \$1,200 - 2,400**



**1279**  
 Dave Jones Collection: 14 Original  
 Visual Effects 35mm Film Clips  
**Star Wars:  
 Episode IV - A New Hope (1977)**

14 original visual effects 35mm film clips from George Lucas' Star Wars: A New Hope. These were used in test shots when compositing live action scenes with visual effects. This lot comes from the collection of veteran model maker Dave Jones. It includes clips of the Death Star, Millennium Falcon, Darth Vader's Star Destroyer, and Han Solo (Harrison Ford) and Luke Skywalker (Mark Hamill) in gunner seats, as well as a tin hand-labeled "STAR WARS TESTS, NEGS, ETC." The tin exhibits scuffs and scratches with tape residue and edge wear on film. Dimensions: (tin) 3" x 3" x 1.5" (7.75 cm x 7.75 cm x 3.75 cm)

**Estimate: \$800 - 1,600**



**1280**  
 Stuart Ziff Collection: "TIE Tie"  
 (TIE Fighter Necktie) Gag Gift  
**Industrial Light & Magic (ILM)**

A "TIE Tie" gag gift given by Industrial Light & Magic (ILM) co-founder Richard Edlund to Academy Award®-winning effects artist Stuart Ziff. Known jokingly as a "TIE tie" due to being both tied to resemble a wearable tie and printed throughout with black TIE fighter graphics, this clear celluloid tie comes from Ziff's collection. The celluloid exhibits yellowing and staining, most visibly around the knot, and several graphics have flaked off from age.

**Estimate: \$400 - 800**

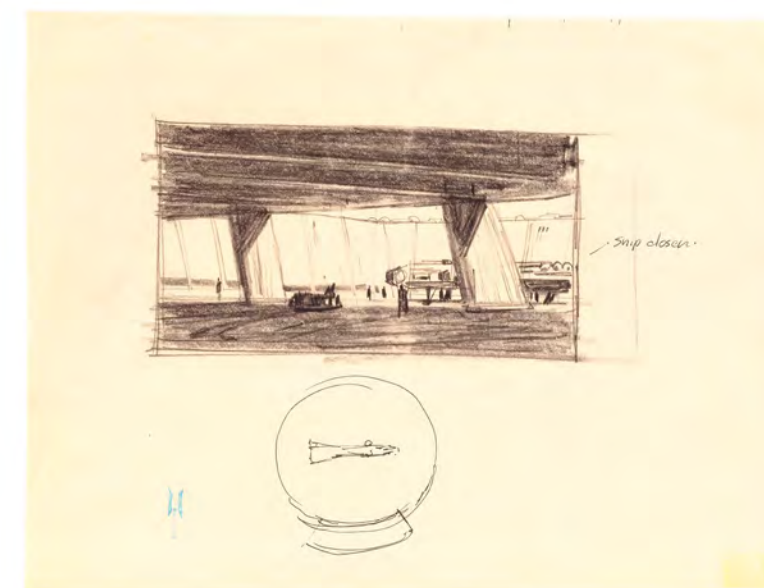

**1281**  
 Hand-Drawn Ralph McQuarrie  
 Mos Eisley Spaceport Docking Area  
 Concept Sketch  
**Star Wars:  
 Episode IV - A New Hope (1977)**

A concept sketch of the Mos Eisley spaceport docking area hand-drawn by concept artist Ralph McQuarrie for George Lucas' Star Wars: A New Hope. Han Solo (Harrison Ford) parked the Millennium Falcon, originally called the Pirate Ship in Lucas' early script, in a Mos Eisley spaceport. This sketch featuring the Falcon is rendered and labeled "Ship closer" in graphite and blue pencil on drawing paper. It is also featured on page 107 of the Abrams publication Star Wars Art: Ralph McQuarrie. The paper exhibits edge wear and some discoloration from age. Dimensions: 8.5" x 11" (21.75 cm x 28 cm) Sold without copyright; see notice in the Buyer's Guide.

**Estimate: \$4,000 - 8,000**



**1282**  
 Framed Hand-Drawn Ralph McQuarrie Female Luke Skywalker Hanging from Tree Concept Sketch  
**Star Wars: Episode IV - A New Hope (1977)**

A framed concept sketch of a female Luke Skywalker hanging from a tree hand-drawn by production illustrator Ralph McQuarrie for George Lucas' Star Wars: A New Hope. McQuarrie drew this sketch in between the second and third drafts of Lucas' screenplay, during which time the director considered using a female Luke. In the second draft, Luke's lifepod crashed into a tree. This sketch is rendered in graphite on paper. It comes framed behind glass in a brown wooden frame with a hanging wire on the reverse. This drawing is also featured on page 76 of the Abrams publication Star Wars Art: Ralph McQuarrie. It exhibits crinkling. Dimensions: 19" x 23" x 1" (48.25 cm x 58.5 cm x 2.5 cm) Sold without copyright; see notice in the Buyer's Guide.

**Estimate: \$2,500 - 5,000**

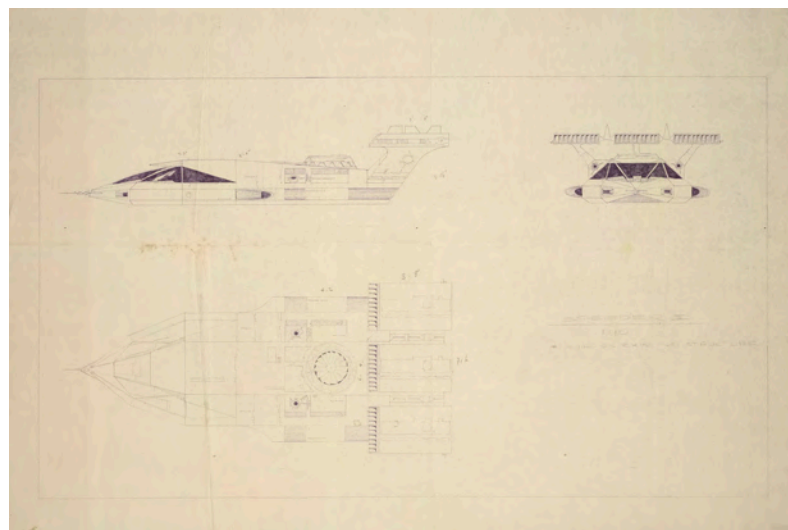

**1283**  
 Matted Printed Harry Lange Landspeeder Design  
**Star Wars: Episode IV - A New Hope (1977)**

A matted and printed Harry Lange landspeeder blueprint from the production of George Lucas' Star Wars: A New Hope. V-35 landspeeders floated through the desert streets of Mos Eisley and the Lars family kept one in the garage at their homestead. This printed copy of a design depicting bird's-eye, front, and side views of a landspeeder was originally rendered and labeled "Speeder II 1:10" by pioneering designer and concept artist Lange. Production distributed copies of this style as reference for the construction of VFX model miniatures. This print comes framed behind plastic with white matte board. It exhibits fold lines and brown staining from production use. Dimensions: 32" x 44" (81.5 cm x 111.75 cm)

**Estimate: \$2,000 - 4,000**

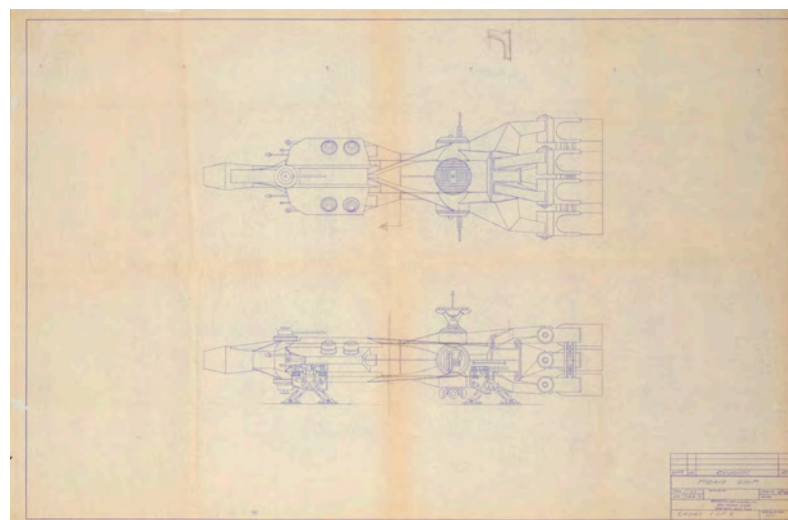

**1284**  
 Matted Printed Joe Johnston Pirate Ship (Millennium Falcon) Production Dyeline  
**Star Wars: Episode IV - A New Hope (1977)**

A matted and printed Joe Johnston dyeline of the Pirate Ship (Millennium Falcon) from the production of George Lucas' Star Wars: A New Hope. Han Solo (Harrison Ford) piloted the Falcon, originally called the Pirate Ship in Lucas' early script, throughout the franchise. This dyeline is a printed copy of two drawings of the ship rendered, dated "13Aug75," and initialed by Industrial Light & Magic (ILM) visual effects artist Johnston for reference for the construction of VFX model miniatures during production. It comes framed behind plastic with white matte board. The dyeline exhibits liquid streaks, visible crinkling, and some stray sketches. Dimensions: 32" x 44" (81.5 cm x 111.75 cm)

**Estimate: \$3,000 - 6,000**



**1285**  
 Charles Lippincott Collection:  
 Production Used Cantina Alien Design Prints  
**Star Wars: Episode IV - A New Hope (1977)**

Production used cantina alien design prints from George Lucas' Star Wars: A New Hope. Various aliens lounged in the cantinas throughout the film. This lot comes from the collection of the film's advertising and publicity supervisor Charles "Charley" Lippincott. It consists of 24 copies of various alien types that appear within the cantina. These copies come in a manilla folder marked "Artwork-Production" with an official "Charles Lippincott" stamp on the front, handwritten notes in red pen, and a note paperclipped to the inside. This lot exhibits fading ink and minor stains to the folder. Dimensions: 9" x 15" x 0.25" (23 cm x 38.25 cm x 0.75 cm)

**Estimate: \$800 - 1,600**

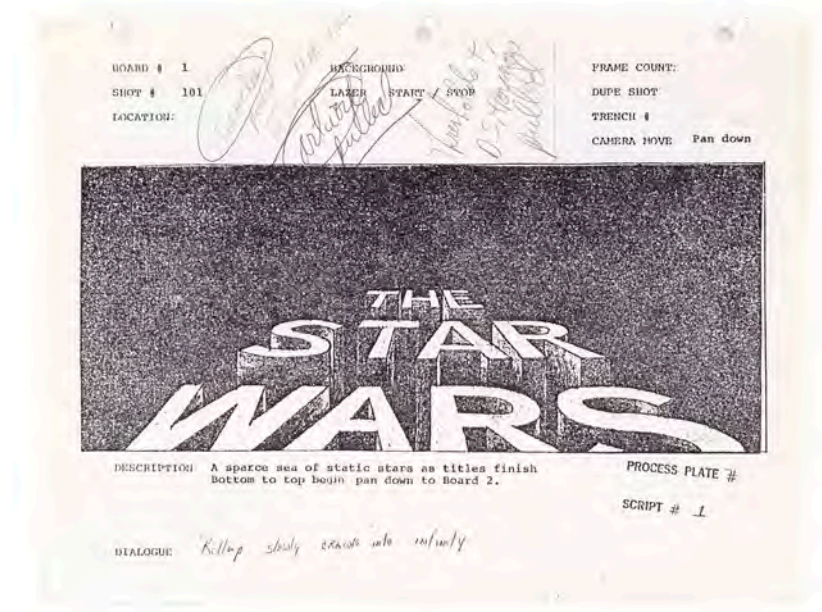

**1286**  
 Annotated Opening Crawl Storyboard Copy  
**Star Wars: Episode IV - A New Hope (1977)**

An annotated opening crawl storyboard copy from George Lucas' Star Wars: A New Hope. This crawl was created by Industrial Light & Magic (ILM) as a visual test before locking the final in-camera version added to prints in lusophone theatrical markets. This opening crawl storyboard copy is labeled "BOARD #1" and from "SCRIPT #1." The storyboard features handwritten notes along the top in pen and graphite. This lot exhibits creases, folds, and minor tears along the edges. Dimensions: 8.5" x 11" (21.75 cm x 28 cm)

**Estimate: \$600 - 1,200**

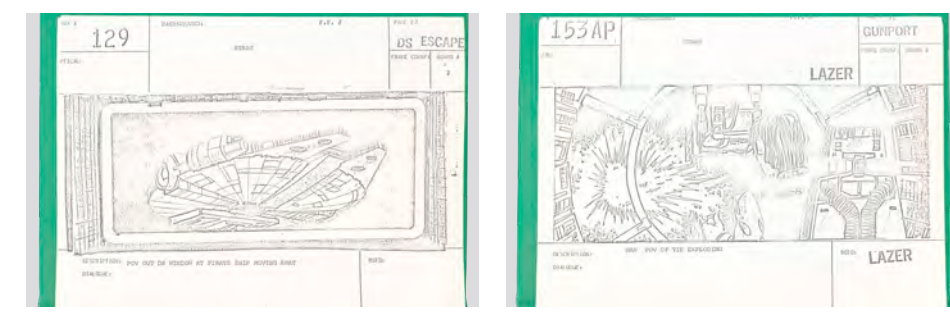

**1287**  
 Charles Lippincott Collection:  
 Production Storyboard Binder with Negative Element Reports  
**Star Wars: Episode IV - A New Hope (1977)**

A production storyboard binder with negative element reports from George Lucas' Star Wars: A New Hope. This binder was created by production to explain the usage of the optical and control functions from Industrial Light & Magic (ILM). This lot comes from the collection of the film's advertising and publicity supervisor Charles "Charley" Lippincott. It consists of a green three-ring binder featuring 90 pages of storyboard copies and corresponding negative element reports with printed annotations, including the binder's objective page from ILM. This lot exhibits grime and ink residue to the cover and a broken sheet lifter. Dimensions: 11" x 12" x 3" (28 cm x 30.5 cm x 7.75 cm)

**Estimate: \$3,000 - 6,000**

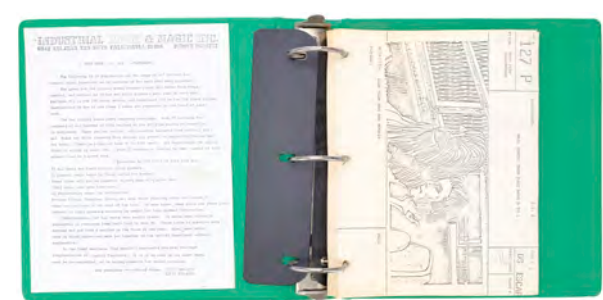



**1288**  
 Extensive Production Budget and Cost Binder Set  
**Star Wars: Episode IV - A New Hope (1977)**

An extensive production budget and cost binder set from George Lucas' Star Wars: A New Hope. Production made budget expenses for filming in the United States and the United Kingdom. This lot consists of a 263-page black three-ring binder with handwritten and printed annotations and dividers labeled "UK Prelim. Budget 4/25/78" and "US 4/27/ 78"; a blue cloth-covered three-ring binder with 94 pages and dividers labeled "Star Wars #1 Budget 3/15/76" and "12/17/77 F03/F04 Totals"; and an 80-page blue folder with handwritten and printed annotations. This lot exhibits discoloration. Dimensions: 10.5" x 11.5" x 2" (26.75 cm x 29.25 cm x 5 cm)

**Estimate: \$2,500 - 5,000**



**1290**  
 Charles Lippincott Collection:  
 Pair of Printed Leia Hologram Diagram Packets  
**Star Wars: Episode IV - A New Hope (1977)**

Two printed packets of diagrams from George Lucas' Star Wars: A New Hope. Luke Skywalker (Mark Hamill) happened across a hologram of Princess Leia (Carrie Fisher) while cleaning up droids his uncle purchased on Tatooine, and later played back the entire message after being saved by Obi-Wan Kenobi (Alec Guinness). This lot comes from the collection of Charles "Charley" Lippincott. Each contains five stapled black-and-white diagrams of shots from the hologram sequence with Industrial Light and Magic (ILM) annotations printed in the margins and one page stamped "Charles Lippincott Used This Item Marketing & Promoting Star Wars." They exhibit minor staining and wear. Dimensions: (each) 13" x 8" (33 cm x 20.5 cm)

**Estimate: \$600 - 1,200**

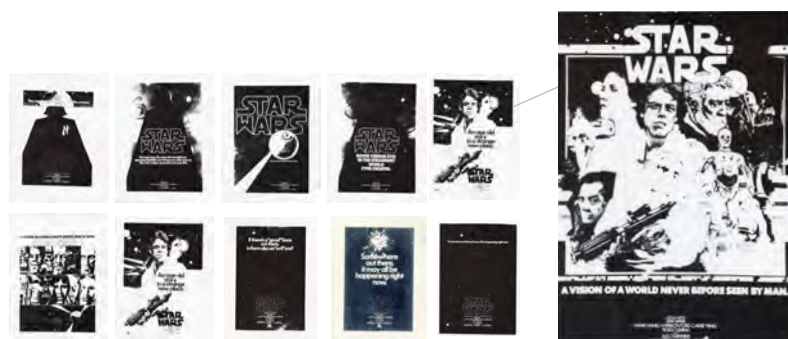

**1289**  
 Charles Lippincott Collection:  
 Set of 17 Poster Concept Prints  
**Star Wars: Episode IV - A New Hope (1977)**

17 poster concept prints from the promotion of George Lucas' Star Wars: A New Hope. 20th Century Fox workshoped a variety of promotional designs and taglines, including "Somewhere out there, it may all be happening right now" and "An age old story in a strange new place," before settling on "A long time ago, in a galaxy far, far away." This lot comes from the collection of the film's advertising and publicity supervisor Charles "Charley" Lippincott. It consists of 17 studio-printed black-and-white copies of 12 distinct poster concepts, of which none were ultimately used. They exhibit minor edge wear throughout. Dimensions: (each) 8.5" x 11" (21.75 cm x 28 cm)

**Estimate: \$800 - 1,600**



**1291**  
 Charles Lippincott Collection:  
 Marcia Lucas' Editorial Crew T-Shirt  
**Star Wars: Various Productions**

A crew T-shirt from the production of George Lucas' Star Wars: A New Hope. T-shirts of this style featuring artwork by celebrated sci-fi concept artist Ralph McQuarrie were issued to the production staff, including Lucas' wife and editor Marcia Lucas, though it remains unknown if she ever wore this shirt. This gray cotton T-shirt (size S) comes from the collection of the film's advertising and publicity supervisor Charles "Charley" Lippincott. It features a graphic depicting a TIE fighter chasing an X-wing, a red planet, and a blue "Star Wars" logo. The reverse is emblazoned "Editorial Marica [sic]" in blue velvet. The shirt exhibits some discoloration and frayed fabric.

**Estimate: \$1,000 - 2,000**



**1292**  
 Charles Lippincott Collection:  
 "Star Wars" X-Wing Crew T-Shirt  
**Star Wars: Episode IV - A New Hope (1977)**

A "Star Wars" X-wing crew shirt from the production of George Lucas' Star Wars: A New Hope. Given to Industrial Light & Magic (ILM) crew members early in production, this style of shirt came to be known as the "Star Wars" shirt due to the letter "W" being cut off. This beige cotton crew-cut T-shirt (size L) comes from the collection of the film's advertising and publicity supervisor Charles "Charley" Lippincott. It features the words "STAR WARS" in bold red and black block letters behind an early illustration of an X-wing. The shirt exhibits mild discoloration and a stretched hem.

**Estimate: \$1,000 - 2,000**



**1293**  
 Charles Lippincott Collection:  
 Printed John Van Hamersveld Logo Proof Sheet  
**Star Wars: Episode IV - A New Hope (1977)**

A printed proof sheet of graphic artist John Van Hamersveld's logo designs for the promotion of George Lucas' Star Wars: A New Hope. After joining Lucasfilm in 1975, advertising and publicity supervisor Charles "Charley" Lippincott commissioned early logo designs from John Van Hamersveld Design Studio which were later replaced. This printed proof sheet featuring four sizes of an early concept design for the film's logo in black text comes from the collection of Lippincott. It exhibits creased and discolored edges with minor staining. Dimensions: 11" x 14.25" (28 cm x 36.25 cm)

**Estimate: \$600 - 1,200**



**1294**  
 Framed Ralph McQuarrie Vintage Supersnipe  
 Laser Duel Production Illustration Print  
**Star Wars: Episode IV - A New Hope (1977)**

A vintage Supersnipe print of a laser duel production illustration drawn by production illustrator Ralph McQuarrie for the production of George Lucas' Star Wars: A New Hope. Part-owned by Lucas at the time of A New Hope's release, New York comic art gallery Supersnipe specialized in illustrations by famous comics artists. McQuarrie drew the original production illustration depicting the "laser duel" between Darth Vader and Luke Skywalker circa February 14, 1975. This vintage full-color print comes mounted behind glass in a wooden frame. The frame exhibits minor scuffing from handling. Dimensions: 21" x 27" x 1" (53.5 cm x 68.75 cm x 2.5 cm)

**Estimate: \$800 - 1,600**



**1295**  
Dave Jones Collection: "Chaykin"  
Comic-Con Special Poster  
**Star Wars:**  
**Episode IV - A New Hope (1977)**

A "Chaykin" Comic-Con special poster made for the promotion of George Lucas' Star Wars: A New Hope. Howard Chaykin was commissioned by 20th Century Fox to illustrate a Star Wars-centric comic book series, which led to his designing this colorful vintage poster featuring characters such as Luke Skywalker, Han Solo, Princess Leia, and Darth Vader. Though not the official theatrical poster, this style of poster—now known as the "Chaykin"—is considered the first-ever Star Wars poster, with copies sold for around a dollar at San Diego Comic-Con in 1976. The poster comes from the collection of veteran model maker Dave Jones. It exhibits pinholes in the corners, some creasing and edge tears from being rolled for storage, and tape residue on the reverse. Dimensions: 29" x 20" (74 cm x 51 cm)

**Estimate: \$3,000 - 6,000**



**1296**  
International Style "A"  
First Print One-Sheet  
**Star Wars:**  
**Episode IV - A New Hope (1977)**

An international style "A" first print one-sheet from the promotion of George Lucas' Star Wars: A New Hope. The poster features art by Tom Jung depicting Luke Skywalker (Mark Hamill) raising his lightsaber above Princess Leia (Carrie Fisher) with Darth Vader (David Prowse) and the Death Star looming behind. 20th Century Fox released four separate print runs of this style. This full-color one-sheet has no "PG" Rating Box and features a "77/21-0" National Screen Services reference number, demarcating it as a true First Printing example. It is flat-folded, as issued, and exhibits minor creasing along the fold lines. Dimensions: 41" x 27" (104.25 cm x 68.75 cm)

**Estimate: \$1,000 - 2,000**



**1297**  
International Style "C"  
One-Sheet  
**Star Wars:**  
**Episode IV - A New Hope (1977)**

An international style "C" one-sheet from the promotion of George Lucas' Star Wars: A New Hope. The poster features art by Tom Chantrell depicting Luke Skywalker (Mark Hamill), Leia (Carrie Fisher), and Han Solo (Harrison Ford) at the center with Darth Vader (David Prowse) and the Death Star hovering ominously above. Other characters and scenes from the film encompass the main characters' borders. This original, full-color one-sheet also features the credits list and the 20th Century Fox copyright at the bottom. It is flat-folded, as issued, and exhibits minor creasing along the fold lines. Dimensions: 41" x 27" (104.25 cm x 68.75 cm)

**Estimate: \$1,500 - 3,000**

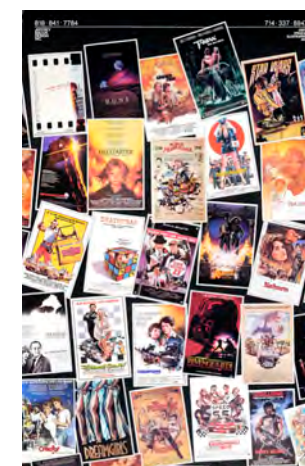

**1298**  
Promotional Poster Collage of Drew Struzan's  
and Jeffrey Bacon's One Sheets  
**Various Productions**

A promotional poster collage of Drew Struzan's and Jeffrey Bacon's one sheets from various productions circa 1987. Both were responsible for many 1980s film posters used as advertising and home-video box artworks. Originating from Bacon's personal collection, this full-color poster is printed on glossy paper used for self-promotion for client acquisition. Featured in this collage are one-sheet art samples for various film posters, notably those from the Indiana Jones, Muppets, and Star Wars franchises. The lot exhibits edgewear, creasing, cracking, and curling from rolled-up storage. Dimensions: 27" x 41" (68.5 cm x 104.25 cm)

**Estimate: \$1,200 - 2,400**



**1300**  
David Prowse and Alec Guinness—Autographed Still  
**Star Wars: Episode IV - A New Hope (1977)**

A black-and-white still from behind-the-scenes of George Lucas' Star Wars: A New Hope. The still features David Prowse and Alec Guinness in their Darth Vader and Obi-Wan Kenobi costumes, respectively. It is autographed "I am the master now Obi Wan! Dave Prowse Darth Vader" in blue marker by Prowse and "Good wishes, Alec Guinness - Pompous Ass?" with an arrow pointed towards Prowse in red marker by Guinness. The still exhibits minor smudges and edge wear from handling. Dimensions: 8.5" x 10" (21.75 cm x 25.5 cm)

**Estimate: \$2,000 - 4,000**

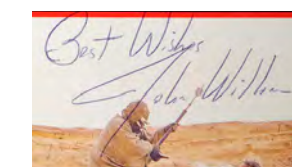

**1299**  
Promotional Copy of Dual-LP Soundtrack with Poster  
and Insert Hand-Signed by John Williams  
**Star Wars: Episode IV - A New Hope (1977)**

A promotional copy of a dual-LP soundtrack from George Lucas' Star Wars: A New Hope with a poster and insert hand-signed by composer John Williams. This lot consists of a black-and-white gatefold cover labeled "Demonstration Not For Sale" with 12 color-printed stills and a vintage signature by Williams in black ink on the interior. Included are two black vinyl records, a double-sided liner notes sheet with track descriptions, and a fold-out color promotional poster designed by artist John Berkey. The lot exhibits ring wear on the cover and edge wear throughout. Dimensions: 12.5" x 12.5" x 2.5" (31.75 cm x 31.75 cm x 6.5 cm)

**Estimate: \$2,000 - 4,000**

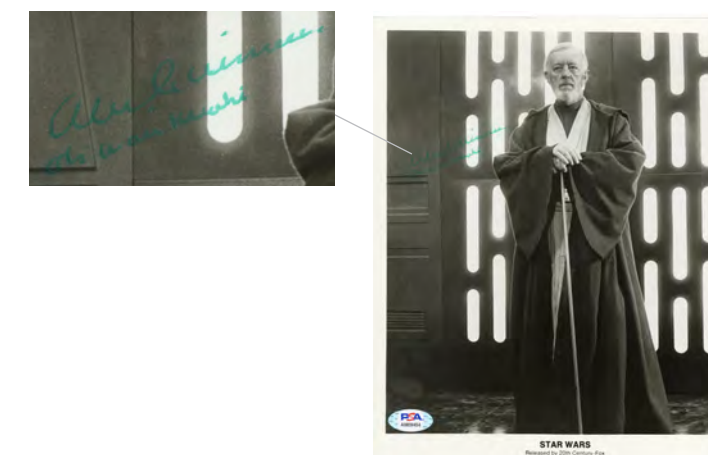

**1301**  
Alec Guinness—Autographed Obi-Wan Kenobi Still  
**Star Wars: Episode IV - A New Hope (1977)**

A promotional still of Obi-Wan Kenobi (Alec Guinness) from George Lucas' Star Wars: A New Hope autographed by Guinness. This black-and-white still labeled "Star Wars: Released by 20th Century Fox" at bottom is signed "Alec Guinness, Obi-Wan Kenobi." Also included are a protective plastic sleeve and a Letter of Authenticity from PSA/DNA Authentication Services. The ink exhibits some color fading from age. Dimensions: 8.5" x 11" (21.75 cm x 28 cm)

**Estimate: \$2,000 - 4,000**



**1302**  
 Editor-Autographed Academy Awards® Photo  
**Star Wars: Episode IV - A New Hope (1977)**

An editor-autographed Academy Awards® photo from the ceremony that awarded George Lucas' Star Wars: A New Hope. The film won the Film Editing award at the 50th Academy Awards® held on April 3, 1978 at L.A.'s Dorothy Chandler Pavilion. This lot consists of a color printed landscape-oriented photo of Richard Chew, Marcia Lucas, and Paul Hirsch holding their statuettes at the ceremony, with their names, the year, and the category they won, with the Star Wars title logo and Academy Awards® logo. It is signed in silver-color ink by the three editors. It exhibits very minimal wear to the corners. Dimensions: 11" x 14" (28 cm x 35.75 cm)

**Estimate: \$800 - 1,600**



**1303**  
 Joe Viskocil's Personal Portfolio Album  
**Various Productions**

Joe Viskocil's personal portfolio album from various genre productions, including but not limited to Star Wars: A New Hope, Battlestar Galactica, Ghostbusters, Apollo 13, Terminator, and Independence Day. This lot features a black binder consisting of Viskocil's personal portfolio numbering 38 double-sided pages, containing large format color photos of special effect shots Viskocil oversaw, each organized by production title. Also included are business cards, unused stickers, and a large embroidered patch for his production company, Viskocil Effects. The lot exhibits minor edge wear, scuffing, color fade, and discoloration marks. Dimensions: 12.5" x 15" x 2.5" (31.75 cm x 38.25 cm x 6.5 cm)

**Estimate: \$800 - 1,600**



**1304**  
 Dave Jones Collection:  
 ICONS Replica X-Wing Starfighter Model  
**Star Wars: Episode IV - A New Hope (1977)**

An ICONS replica X-wing fighter model miniature from the promotion of George Lucas' Star Wars: A New Hope. X-wings were instrumental to the Rebel attack on the Death Star. This ornately detailed resin model, one of a 1,977-piece release in 1997, comes from the collection of veteran model maker Dave Jones. It is aged, hand-painted, and mounted with clear plastic pipe to a gray resin base molded to resemble the Death Star's surface and affixed with a plaque engraved "X-wing Fighter." Also included are an ICONS/Lucasfilm Certificate of Authenticity; a booklet, pamphlet, and mail card; four instructional pages; a plaque; a case, and the original box. The model exhibits minor imperfections and grime buildup. Dimensions: 25" x 27.5" x 18" (63.5 cm x 70 cm x 45.75 cm)

**Estimate: \$2,000 - 4,000**



**1305**  
 Dave Jones Collection:  
 ICONS Imperial TIE Fighter Replica Model  
**Star Wars: Episode IV - A New Hope (1977)**

An ICONS imperial TIE fighter replica model from the promotion of George Lucas' Star Wars: A New Hope. Imperial TIE fighters engaged in space warfare with Rebel X-wings attempting to destroy the Death Star. This ornately detailed resin model, one of a 1,977-piece release, comes from the collection of veteran model maker Dave Jones. It is hand-painted gray and mounted via clear plastic pipe to a gray resin base molded to resemble the Death Star's surface on top of a glossy black base. Also included are an ICONS/Lucasfilm Certificate of Authenticity; four instructional pages; a booklet, pamphlet, mail card, and plaque; and the original box. The model exhibits minor imperfections from the manufacturing process. Dimensions: 21.5" x 21.5" x 26.5" (54.75 cm x 54.75 cm x 67.5 cm)

**Estimate: \$3,000 - 6,000**



**1306**  
 Charles Lippincott Collection:  
 Han Solo Small Head SW12A AFA 80 NM Action Figure  
**Star Wars Toys**

A Han Solo small head SW12A AFA 80 NM action figure from Kenner's Star Wars toy line. Released in 1978 following George Lucas' Star Wars: A New Hope, this AFA 80-graded, acrylic-encased figure stands 3.75" in its original bubble with a punched SW12A cardback and C90, B75, and F80 subgrades, and also includes a black blaster pistol. This lot comes from the collection of the film's advertising and publicity supervisor Charles "Charley" Lippincott. It exhibits minor grime on the case. Dimensions: 10.75" x 8.25" x 2" (21 cm x 27.5 cm x 5.25 cm) Included with this lot is an original brochure printed for the 2016 convention MidAmeriCon 2 ("MAC II") which re-united Gary Kurtz, Alan Dean Foster, and Marc Pevers. The brochure, titled "Kismet or The Force Awakens," was written by Ken Keller, who was the original Chairman of MidAmeriCon when Lippincott put together a Star Wars display in September 1976. The article recalls details of that pre-release convention, and sets the stage for the 2016 MAC II reunion.

**Estimate: \$3,000 - 6,000**



**1307**  
 Charles Lippincott Collection:  
 Boba Fett Large Size Action Figure - Sealed  
**Star Wars Toys**

A sealed Boba Fett large size action figure from Kenner's Star Wars toyline. Released in 1979 following George Lucas' Star Wars: A New Hope and before the release of the sequel, this figure is sealed in its original box and comes from the collection of the film's advertising and publicity supervisor Charles "Charley" Lippincott. The box exhibits wear along the edges, creasing in the front flap, and scuffing to its window. Dimensions: 16" x 5" x 4" (40.75 cm x 12.75 cm x 10.25) Included with this lot is an original brochure printed for the 2016 convention MidAmeriCon 2 ("MAC II") which re-united Gary Kurtz, Alan Dean Foster, and Marc Pevers. The brochure, titled "Kismet or The Force Awakens," was written by Ken Keller, who was the original Chairman of MidAmeriCon when Lippincott put together a Star Wars display in September 1976. The article recalls details of that pre-release convention, and sets the stage for the 2016 MAC II reunion.

**Estimate: \$400 - 800**

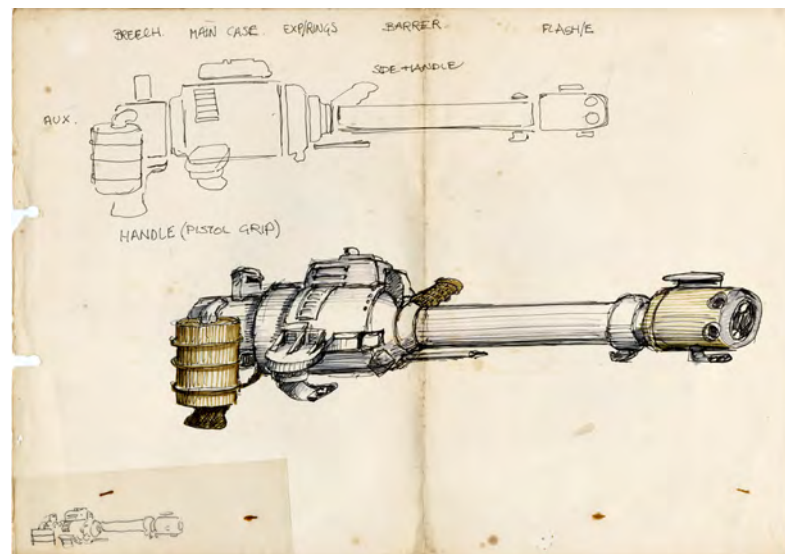

**1308**  
 Hand-Drawn Michael Ford  
 Hoth Rebel Blaster Cannon Concept Sketch  
**Star Wars: Episode V - The Empire Strikes Back (1980)**

A concept sketch of a Hoth Rebel blaster cannon hand-drawn by set decorator Michael Ford for the production of Irvin Kershner's *Star Wars: The Empire Strikes Back*. The Rebels used mounted medium repeating blaster cannons to protect Echo Base from Imperial forces during the Battle of Hoth. This sketch depicting side views of a cannon and two other weapons components is rendered in mixed media on sketch paper and vellum with several components, such as "Breach" and "Flash," annotated in pen by Ford. It exhibits tearing, staining, fold lines, and pinholes. Dimensions: 17" x 12" (43.25 cm x 30.5 cm) Sold without copyright; see notice in the Buyer's Guide.

**Estimate: \$600 - 1,200**

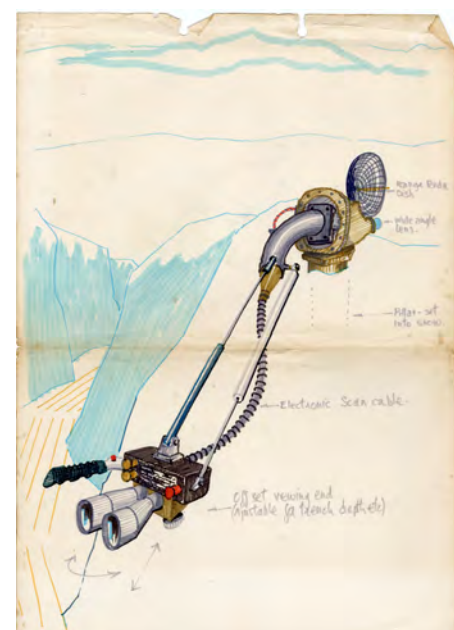

**1309**  
 Hand-Drawn Michael Ford  
 Hoth Rebel Periscope Concept Sketch  
**Star Wars: Episode V - The Empire Strikes Back (1980)**

A concept sketch of a Hoth Rebel periscope hand-drawn by set decorator Michael Ford for the production of Irvin Kershner's *Star Wars: The Empire Strikes Back*. Rebels used electronic periscopes stationed in Echo Base to monitor the Imperial invasion of Hoth. This sketch of a periscope in an ice cave is rendered in marker on sketch paper with several components, such as "Range Rada Dish" (sic) and "electronic scan cable," annotated by Ford. The paper exhibits tearing along its edges, staining, and fold lines from production. Dimensions: 17" x 12" (43.25 cm x 30.5 cm) Sold without copyright; see notice in the Buyer's Guide.

**Estimate: \$600 - 1,200**

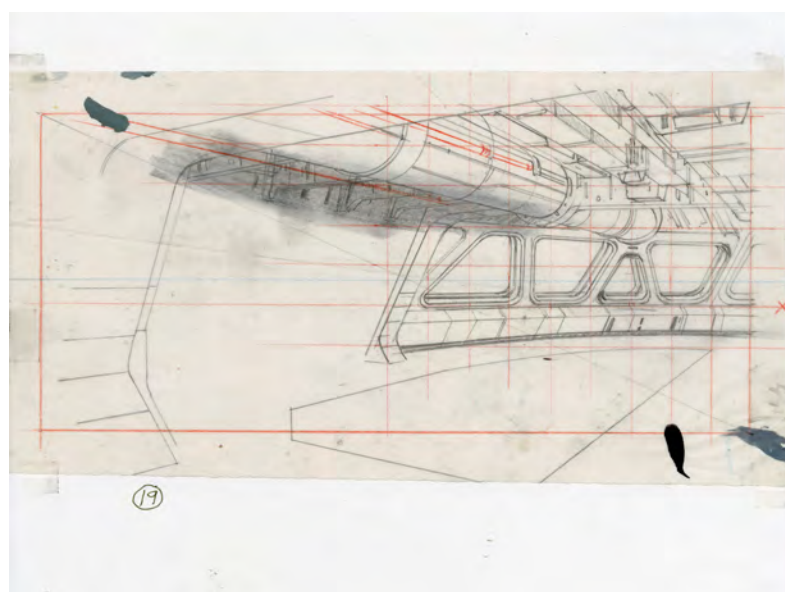

**1310**  
 Hand-Drawn Ralph McQuarrie  
 Star Destroyer Bridge Production Illustration Prelim  
**Star Wars: Episode V - The Empire Strikes Back (1980)**

A prelim for a production illustration of a Star Destroyer Bridge hand-drawn by design consultant and conceptual artist Ralph McQuarrie for Irvin Kershner's *Star Wars: The Empire Strikes Back*. McQuarrie created multiple production illustrations of Darth Vader on the Star Destroyer's bridge during pre-production in July 1978. This prelim depicting the interior left side of the bridge is rendered in graphite and orange pencil on bordered vellum. It is also featured on page 337 of the Abrams publication *Star Wars Art: Ralph McQuarrie*. The vellum exhibits ink smudging and paint stains throughout. Dimensions: 11" x 5.75" (28 cm x 14.75 cm) Sold without copyright; see notice in the Buyer's Guide.

**Estimate: \$3,000 - 6,000**



**1311**  
 Hand-Drawn Ralph McQuarrie  
 Cloud City and Dagobah Thumbnail Sketches  
**Star Wars: Episode V - The Empire Strikes Back (1980)**

A sheet of thumbnail sketches of Cloud City and Dagobah hand-drawn by Ralph McQuarrie for the production of Irvin Kershner's *Star Wars: The Empire Strikes Back*. McQuarrie worked on the film in multiple capacities, including designing key locations during pre-production. Three of these thumbnail sketches depict views of the Millennium Falcon gunfight in Cloud City and Dagobah's marshy treeline, while one is incomplete. They draw from illustrations created by McQuarrie during pre-production in 1979. They are rendered in graphite and ink on paper which exhibits smudging and staining throughout. Dimensions: 8.5" x 11.25" (21.75 cm x 28.75 cm) Sold without copyright; see notice in the Buyer's Guide.

**Estimate: \$2,000 - 4,000**

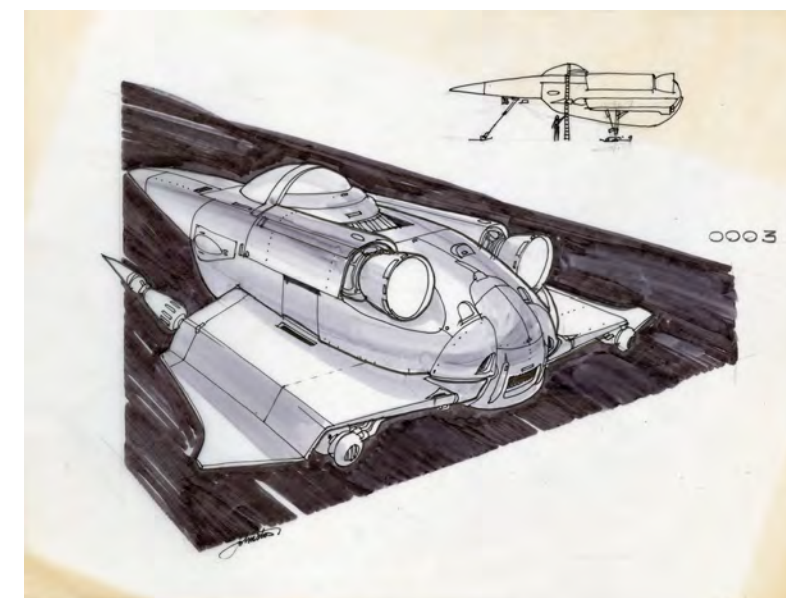

**1312**  
 Hand-Drawn Joe Johnston  
 Early Snowspeeder Concept Sketch  
**Star Wars: Episode V - The Empire Strikes Back (1980)**

An early snowspeeder concept sketch hand-drawn by visual effects art director Joe Johnston for the production of Irvin Kershner's *Star Wars: The Empire Strikes Back*. Rebel pilots flew their snowspeeders throughout the Battle of Hoth, including when Luke Skywalker (Mark Hamill) used his to take down an Imperial AT-AT. This early sketch depicting back and side views of a snowspeeder is rendered in mixed media on paper labeled "0003" and signed by Johnston in the bottom left corner. The paper exhibits discolored and bent corners from age and handling. Dimensions: 8.5" x 11" (21.75 cm x 28 cm) Sold without copyright; see notice in the Buyer's Guide.

**Estimate: \$1,500 - 3,000**



**1313**  
 Framed Hand-Drawn Joe Johnston  
 Hoth Battle Storyboard  
**Star Wars: Episode V - The Empire Strikes Back (1980)**

A framed Battle of Hoth storyboard hand-drawn by visual effects art director Joe Johnston for the production of Irvin Kershner's *Star Wars: The Empire Strikes Back*. Rebel and Imperial forces faced off in the trenches of the ice planet Hoth. This storyboard for the Battle of Hoth is rendered in mixed media on paper, numbered "0208," dated "2/78," and initial "J" by Johnston. It comes mounted behind glass in a black wooden frame. The frame exhibits dings and scratching from handling. Dimensions: 10" x 15" x 1" (25.5 cm x 38.25 cm x 2.5 cm) Sold without copyright; see notice in the Buyer's Guide.

**Estimate: \$2,000 - 4,000**



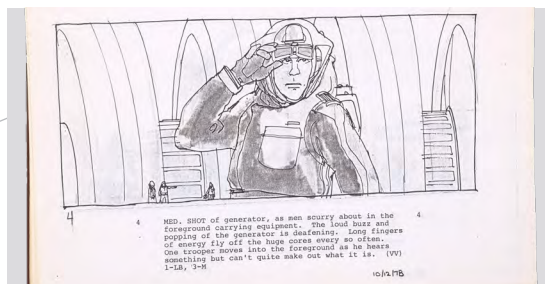

**1314**  
Lorne Peterson Collection:  
Imperial Walker Sequence  
Storyboard Binder  
Star Wars: Episode V -  
The Empire Strikes Back (1980)

An Imperial Walker sequence storyboard binder from Irvin Kershner's Star Wars: The Empire Strikes Back. This brown binder marked "Model Shop" on the front and spine and "Lorne Peterson" labeled on the spine comes from the collection of chief model maker Lorne Peterson. It features 136 pages of storyboards printed on white pages with dates, numbers, and notes, and an abbreviation key. This lot exhibits grime on the exterior from age, discoloration, and sticking pages. Dimensions: 10" x 11.5" x 1.5" (28 cm x 29.25 cm x 10.25 cm)

**Estimate: \$4,000 - 8,000**



**1315**  
Set of Three Yoda Puppet  
Production Reference Photographs  
Star Wars: Episode V -  
The Empire Strikes Back (1980)

Three Yoda (Frank Oz) puppet reference photographs from the production of Irvin Kershner's Star Wars: The Empire Strikes Back. The puppet was constructed by Nick Maley and Stuart Freeborn, with these images taken as visual references for its appearances in the Dagobah sequence. These rare color-printed behind-the-scenes Polaroids depict the fully-dressed and completed puppet seated as seen from right, left, and front views. Each exhibits scratching from production and handling. Dimensions: (each) 4" x 5" (10.25 cm x 12.75 cm)

**Estimate: \$1,200 - 2,400**



**1316**  
Set of 21 Hoth Prop  
Production Photographs  
Star Wars: Episode V -  
The Empire Strikes Back (1980)

21 photographs of Hoth-related props from the production of Irvin Kershner's Star Wars: The Empire Strikes Back. These rare, color-printed, behind-the-scenes Polaroids depict the construction of such recognizable props as Luke Skywalker's (Mark Hamill) electrobinoculars, an A280 Rebel blaster rifle, and a frontal view on an under-construction X-wing model miniature. Several of the photographs are hand-annotated in ink, including one labeled "Power Trench," one labeled "Fields Electric," and a third dated "Peter Thornton. 22.10." The set exhibits light bending, staining, and fading ink throughout from age and production. Dimensions: (each) 4" x 5" (10.25 cm x 12.75 cm)

**Estimate: \$2,000 - 4,000**



**1317**  
Set of Nine  
Cloud City Set  
Production Photographs  
Star Wars:  
Episode V - The Empire  
Strikes Back (1980)

Nine photographs of the Cloud City set from the production of Irvin Kershner's Star Wars: The Empire Strikes Back. These rare, color-printed behind-the-scenes Polaroids depict set decoration created for several key Cloud City locations, including the adorned dining room where Han Solo (Harrison Ford) was delivered to Darth Vader (David Prowse) and several otherworldly statues. They exhibit light bending and staining throughout from age and handling. Dimensions: (each) 4" x 5" (10.25 cm x 12.75 cm)

**Estimate: \$600 - 1,200**

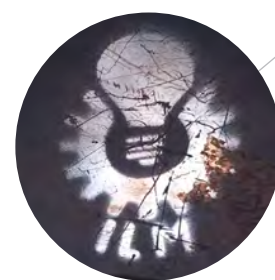

**1319**  
Mole-Richardson Stage Light with ILM Logos  
Industrial Light & Magic (ILM)

A Mole-Richardson stage light from Industrial Light & Magic (ILM). The visual effects company used a number of different stage lights in the creation of many iconic motion picture sequences over the years, and often marked their equipment with their logo. This stage light, built by Mole-Richardson, is made of cast aluminum with maroon enamel, sheet steel, and features a three-pronged house plug, a knob for switching from spot to flood, attachable barn doors, and an Industrial Light & Magic information label. The light itself and the barn doors feature the ILM lightbulb logo stenciled on. The light exhibits scuffing throughout from use and age, and is currently non-functional. Dimensions: 14" x 8" x 10" (35.75 cm x 20.5 cm x 25.5 cm) Contains electronics; see electronics notice in the Buyer's Guide.

**Estimate: \$1,500 - 3,000**



**1318**  
Framed Norway  
Tracked Vehicle  
"Vader in Flames" Decal  
Star Wars:  
Episode V - The Empire  
Strikes Back (1980)

A framed "Vader in Flames" vehicle decal from Irvin Kershner's Star Wars: The Empire Strikes Back. Trac-Master snow vehicles used to tow and support vehicles on the Norway set were emblazoned with the film's production logo. Screen-printed on vinyl, this white-bordered decal features Darth Vader looming through flames before a blue field surrounding the film's title. Its red background was designed to help it blend in with the Trac-Masters' predominantly red paint schemes. This decal comes mounted behind glass in a black wooden frame. It remains attached to its backing paper and unused. Dimensions: 6.5" x 10" x 1" (16.5 cm x 25.5 cm x 2.5 cm)

**Estimate:  
\$1,500 - 3,000**



**1320**  
Set of Three AT-AT Reference  
and Shipment Contact Sheets  
Star Wars: Episode V - The Empire Strikes Back (1980)

Three AT-AT reference and shipment contact sheets from the production of Irvin Kershner's Star Wars: The Empire Strikes Back. Industrial Light & Magic (ILM) produced contact sheets of photos taken throughout the film's production. This lot consists of three contact sheets: one with 38 images of an elephant to reference for the AT-AT's walking movement, one with 33 images of an AT-AT model's foot and a cat, and one labeled "8/78 Blue Screen & Starfields Shipments" with 38 images of a transport truck. They exhibit bending and scratching from use and age, and a stain near the top of the elephant sheet. Dimensions: (each) 11" x 14" (28 cm x 35.75 cm)

**Estimate: \$800 - 1,600**



**1321**  
Set of Five Tauntaun Contact Sheets  
**Star Wars: Episode V - The Empire Strikes Back (1980)**

A set of five tauntaun contact sheets from the production of Irvin Kershner's Star Wars: The Empire Strikes Back. Industrial Light & Magic (ILM) produced contact sheets of the photos taken throughout the production of the film. This lot consists of five contact sheets featuring images of tauntaun models, Phil Tippett and other ILM team members, and a visit to a beach with a camera set up. Two sheets have 36 images, two have 35 images, and one has 37 images. The sheets exhibit bending and scratching from use and age. Dimensions: (each) 11" x 14" (28 cm x 35.75 cm)

**Estimate: \$800 - 1,600**



**1323**  
16mm Film Print of SPFX:  
The Making of ESB Documentary  
**Star Wars: Episode V - The Empire Strikes Back (1980)**

A 16mm film print of SPFX: The Making of ESB documentary from Irvin Kershner's Star Wars: The Empire Strikes Back. Hosted by Mark Hamill, the documentary aired on CBS on September 22, 1980 and detailed the creation of the film's special effects. This 16mm photographic film print is enclosed in a brown-painted metal film canister. Film canister lid features gray tape hand-marked "THE MAKING OF THE EMPIRE STRIKES BACK" in black ink. The film reel has not been tested for playback. The canister exhibits paint chipping, rust staining, tape residue, and scuffing. Measures: 15.25" x 15.25" x 1" (38.75 cm x 38.75 cm 2.5 cm)

**Estimate: \$800 - 1,600**



**1322**  
Doug Beswick-Autographed  
Medium Stop-Motion Surface Gauge Δ  
**Various Productions**

A medium-size stop-motion surface gauge autographed by Doug Beswick. Beswick worked as a stop-motion artist and animator on several of history's most popular films, including Star Wars: The Empire Strikes Back, The Terminator, and Aliens. Beswick used this metal gauge, essential in stop-motion animation, to map scale and distance between puppets and models in animation sequences. It consists of two adjustable rods mounted to an elevated base, which in turn is screwed into a large base. The higher base is signed in silver-color marker by Beswick and exhibits some scratching; the metal rods exhibit some discoloration. Dimensions: 9.5" x 5" x 3.5" (24.25 cm x 12.75 cm x 9 cm)

**Estimate: \$1,000 - 2,000**



**1324**  
26 Production-Used Hand-Drawn and Printed  
George Hull Bispin Cloud City Storyboards  
**Star Wars: Episode V - The Empire Strikes Back (1980)**

26 hand-drawn and printed George Hull Bispin Cloud City storyboards from Irvin Kershner's Star Wars: The Empire Strikes Back. Ephemera was generated during the production of the 1997 re-release celebrating the franchise's 20th anniversary.

This lot consists of 26 production-used storyboards and design copies. They were created by Industrial Light & Magic (ILM) visual effects art director George Hull. One of the storyboards is a rough layout adhered to a board. Some of these designs and storyboards feature handwritten notes in pencil and color. This lot exhibits tears, pin holes, fold creases, and edgewear from production use and storage. Dimensions: 20" x 8" (51 cm x 20.5 cm)

**Estimate: \$800 - 1,600**



**1325**  
Kenner Yoda Action Figure Retailer  
Master Carton and Carded Yoda Figure Δ  
**Star Wars: Episode V - The Empire Strikes Back (1980)**

A Kenner Yoda action figure retailer master pack box and carded Yoda figure from Irvin Kershner's Star Wars: The Empire Strikes Back. This lot consists of an empty cardboard master carton printed with Kenner's logo and informational data. The box exhibits creasing, corner impact damage, and tape removal damage. The ungraded and carded Yoda action figure #38310 exhibits edgewear and warpage within an acrylic case that exhibits minor scuffing. Dimensions: (box) 14" x 9.75" x 6.25" (35.5 cm x 24.75 x 16 cm); (figure) 7" x 10" x 1.5" (17.75 cm x 25.5 cm x 3.75 cm)

**Estimate: \$1,000 - 2,000**



80.5" (204.5 cm)

**1326**  
Illusive Concepts Replica Han Solo  
(Harrison Ford) in Carbonite  
**Star Wars: Episode V - The Empire Strikes Back (1980)**

An Illusive Concepts replica Han Solo (Harrison Ford) in carbonite from Star Wars: The Empire Strikes Back. Created by Illusive Concepts, this replica was produced using the original molds from the Lucasfilm archives to be retailed as a collectible in 1997. This lot consists of one replica statue. Constructed of a cast fiberglass shell with a particle board backing, this collectible piece of art features five intricately designed side control-panel vents. The bottom of this replica features a brass-color metal plaque engraved with "Han Solo in Carbonite" and is numbered "378 of 2,500." This lot exhibits mild cracks and pitting from the molding process and mild separation of the backboard from age. Dimensions: 31.5" x 80.5" x 12" (80 cm x 204.5 cm x 30.5) Special shipping required; see notice in the Buyer's Guide.

**Estimate: \$4,000 - 8,000**



**1327**  
Stuart Ziff Collection: Large Sarlacc Wart  
**Star Wars: Episode Vi - Return Of The Jedi (1983)**

A large sarlacc wart from Richard Marquand's Star Wars: Return of the Jedi. Jabba the Hutt sentenced Luke Skywalker (Mark Hamill) and his friends to die by being cast into the Great Pit of Carkoon, where the sarlacc digested its victims over 1,000 years. This foam wart comes from the collection of chief articulation engineer Stuart Ziff. Constructed by Industrial Light & Magic (ILM), it is applied with a thin urethane skin painted red, orange, and brown and hand-labeled "April" and "Yuma, AZ" - where the Jabba's Palace sequence was filmed - in black marker. It exhibits bubbling and tears around the urethane's edges. Dimensions: 4.5" x 4.5" x 2.5" (11.5 cm x 11.5 cm x 6.5 cm)

**Estimate: \$800 - 1,600**

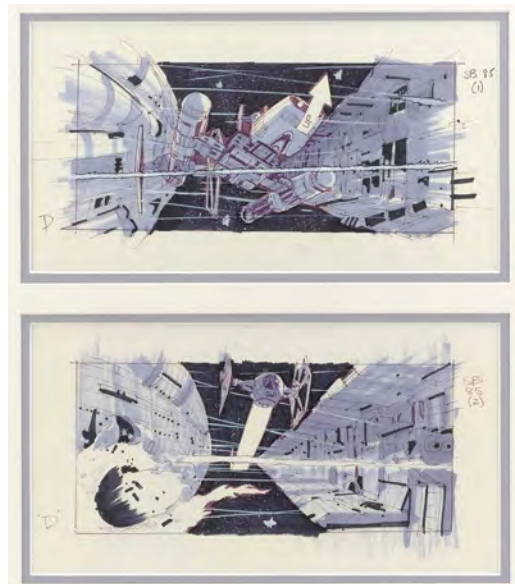

**1328**  
Framed Pair of Hand-Drawn Dave Carson "Space Battle" Storyboards  
**Star Wars: Episode VI - Return Of The Jedi (1983)**

Two framed "Space Battle" storyboards hand-drawn by Industrial Light & Magic (ILM) artist and sculptor Dave Carson for Richard Marquand's Star Wars: Return of the Jedi. In the climactic finale, TIE fighters pursued the Rebel fleet as it fought to destroy the Death Star II. These storyboards - one depicting a Y-wing labeled "SB85 (1)" and one depicting a TIE fighter labeled "SB85 (2)," with "SB" meaning "Space Battle" - are rendered in mixed media on drawing paper signed "D." They come mounted behind glass in a black wooden frame. Both exhibit minor stains. Dimensions: 18" x 20" x 1" (45.75 cm x 51 cm x 2.5 cm) Sold without copyright; see copyright notice in the Buyer's Guide.

**Estimate: \$2,500 - 5,000**

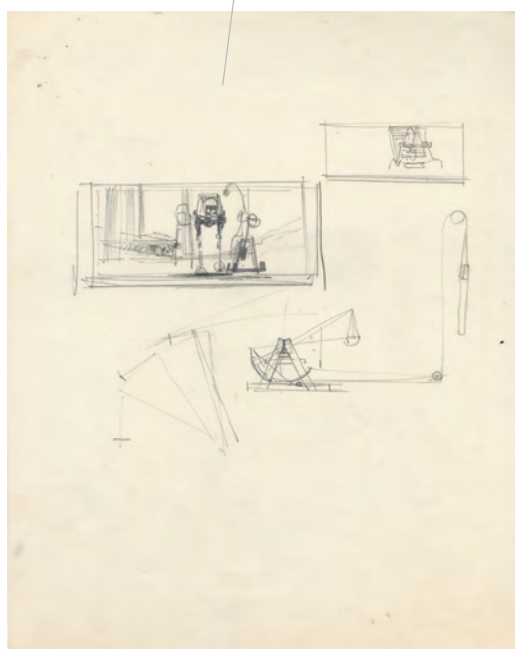
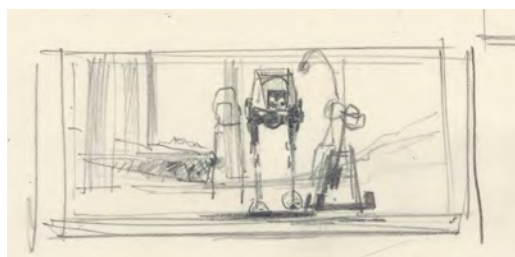

**1329**  
Hand-Drawn Ralph McQuarrie Portfolio Battle of Endor Thumbnail Sketches  
**Star Wars: Episode VI - Return Of The Jedi (1983)**

Battle of Endor thumbnail sketches hand-drawn by concept artist Ralph McQuarrie for his Return of the Jedi Portfolio, a set of production illustration art prints published in conjunction with Richard Marquand's Star Wars: Return of the Jedi. In the film, the Rebels faced off against the Galactic Empire on the forest moon of Endor. McQuarrie created these thumbnails of AT-ATs roaming the forest and an Ewok trebuchet immediately after production as concept sketches for the final portfolio artwork. Rendered in graphite on paper, they are also featured on page 267 of the Abrams publication Star Wars Art: Ralph McQuarrie. The paper exhibits some smudging. Dimensions: 11.5" x 14.5" (29.25 cm x 37 cm) Sold without copyright; see notice in the Buyer's Guide.

**Estimate: \$2,500 - 5,000**

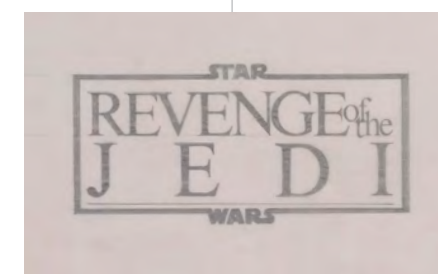

**1330**  
Hand-Drawn Jay Vigon "Revenge of the Jedi" Logo Concept Artwork  
**Star Wars: Episode VI - Return Of The Jedi (1983)**

"Revenge of the Jedi" logo concept artwork hand-drawn by graphic designer Jay Vigon for Richard Marquand's Star Wars: Return of the Jedi. Vigon created this artwork and other promotional materials before the film's title was changed from "Revenge" to "Return." This artwork depicting a "Revenge of the Jedi" logo with "Star" above it and "Wars" below is rendered and signed by Vigon in graphite on tracing paper. It exhibits wear around the edges, including small tears. Dimensions: 13.5" x 17" (34.5 cm x 43.25 cm) Sold without copyright; see notice in the Buyer's Guide.

**Estimate: \$2,000 - 4,000**

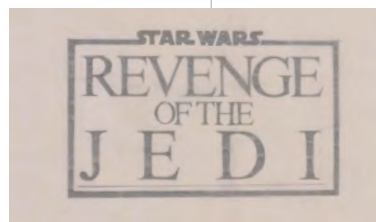

**1331**  
Hand-Drawn Jay Vigon "Revenge of the Jedi" Logo Concept Artwork  
**Star Wars: Episode VI - Return Of The Jedi (1983)**

"Revenge of the Jedi" logo concept artwork hand-drawn by graphic designer Jay Vigon for Richard Marquand's Star Wars: Return of the Jedi. Vigon created this artwork and other promotional materials before the film's title was changed from "Revenge" to "Return." This artwork depicting a "Revenge of the Jedi" logo with "Star Wars" written above it is rendered and signed by Vigon in graphite on tracing paper. It exhibits wear around the edges, including small tears. Dimensions: 13.5" x 17" (34.5 cm x 43.25 cm) Sold without copyright; see notice in the Buyer's Guide.

**Estimate: \$2,000 - 4,000**

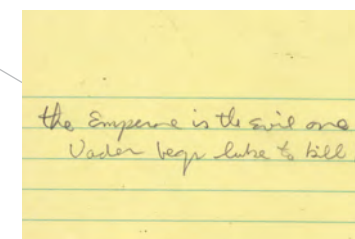
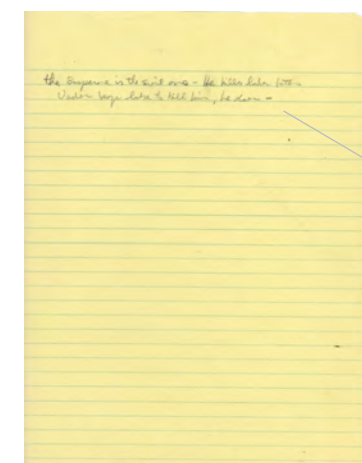

**1333**  
George Lucas' Handwritten Darth Vader and Emperor Story Notes  
**Star Wars: Episode VI - Return Of The Jedi (1983)**

A page of story notes from pre-production on Richard Marquand's Star Wars: Return of the Jedi. George Lucas hand wrote these notes while still in the early draft stage of his and Lawrence Kasdan's script. Written in pencil in Lucas' distinctive handwriting on U.S. letter-size lined paper, these notes consist of two points: "The Emperor is the evil one - he kills Luke's father" and "Vader begs Luke to kill him, he does." The paper's top left right corner is torn, and the notes exhibit some eraser smudges. Dimensions: 8.5" x 11" (21.75 cm x 28 cm)

**Estimate: \$1,500 - 3,000**



**1332**  
Luke Skywalker (Mark Hamill) Lightsaber Hilt from Production Molds  
**Star Wars: Episode VI - Return Of The Jedi (1983)**

A Luke Skywalker's (Mark Hamill) lightsaber hilt from Richard Marquand's Star Wars: Return of the Jedi. This resin casting for the lightsaber Skywalker built after losing his father's lightsaber in The Empire Strikes Back was made from original molds created by Industrial Light & Magic (ILM) during production on the prequel trilogy. It features a white glossy finish and sculpted details. It exhibits some cracking and chipping from handling and age. Dimensions: 11.5" x 2" x 2" (29.25 cm x 5.25 cm x 5.25 cm)

**Estimate: \$2,000 - 4,000**



**1334**  
Collection of Jabba the Hutt-Related Production Paperwork  
**Star Wars: Episode VI - Return Of The Jedi (1983)**

Jabba the Hutt-related paperwork from the production of Richard Marquand's Star Wars: Return of the Jedi. Jabba employed skiff guards, bounty hunters, and various henchmen from his palace on Tatooine. This collection consists of 10 pages of Lucasfilm memos and printed Telex messages dated September 28 and 30, 1981, with notes regarding Jabba's skiff guards' weapons and costumes, some of which are handwritten by art director James Schoppe; four color wardrobe continuity Polaroids of a Gamorrean guard hand-annotated with waist measurements; and eight photocopied concept sketches of various guards' weapons. The paperwork exhibits edge wear throughout. Dimensions: (largest) 12" x 15" (30.5 cm x 38.25 cm)

**Estimate: \$2,000 - 4,000**

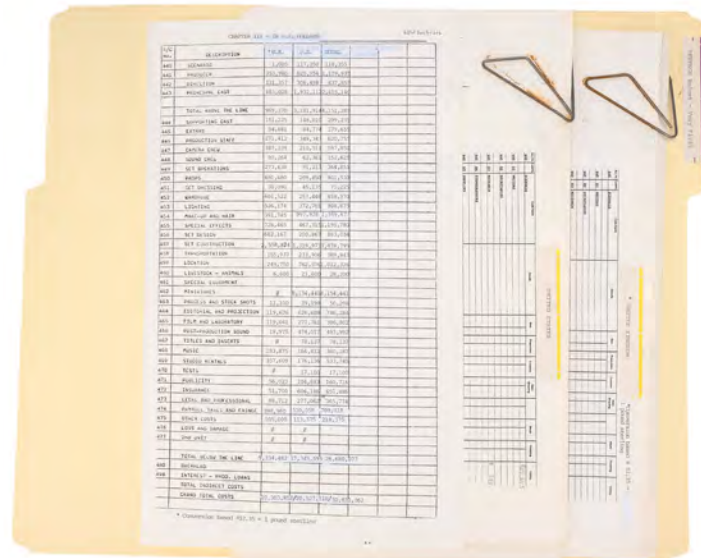

**1335**  
 U.S. and U.K. Production Budget Documents Δ  
**Star Wars: Episode VI – Return Of The Jedi (1983)**

U.S. and U.K. production budget documents from Richard Marquand's Star Wars: Return of the Jedi. Production budgets tracked filming expenses in the United States and the United Kingdom. This lot consists of a one-page expenses total for the U.S. and U.K. with white-out corrections; a paperclipped packet of 63 pages labeled "United Kingdom" with handwritten annotations and white-out corrections; and a 43-page packet labeled "United States" with handwritten annotations. They come in a production manila folder labeled "Revenge Budget - Very First." This lot exhibits rust stains and minor tears. Dimensions: 15" x 9.5" x 0.5" (38.25 cm x 24.25 cm x 1.5 cm)

**Estimate: \$600 - 1,200**



**1336**  
 Jeremy Bulloch's UK Premiere One-Sheet  
**Star Wars: Episode VI – Return Of The Jedi (1983)**

Jeremy Bulloch's one-sheet from the U.K. premiere of Richard Marquand's Star Wars: Return of the Jedi. This poster was originally owned by Bulloch's half-brother, Star Wars producer Robert Watts, before being gifted to the Boba Fett actor. The full-color, US Style A one-sheet paper print is mounted on a hardboard with string on the back for hanging. A print marking on the bottom denotes "RETURN OF THE JEDI ONE SHEET 830013." Also included is a Certificate of Authenticity from Bulloch's estate. The lot exhibits edge wear, surface marking, and grime. Dimensions: 41" x 27" (104 cm x 68.5 cm)

**Estimate: \$1,500 - 3,000**

**1337**  
 Hand-Drawn Ralph McQuarrie Cover Concept Sketches  
**Lando Calrissian And The Mindharp Of Sharu (1983)**

Cover concept sketches hand-drawn by Ralph McQuarrie for L. Neil Smith's Star Wars Legends novel Lando Calrissian and the Mindharp of Sharu. Considered the foremost artist for the Star Wars film franchise, McQuarrie created concept artwork for the book, though none was ultimately utilized. These two sketches of Calrissian playing his Mindharp and wielding his blaster are rendered and annotated in graphite and ink on paper. They were also featured on page 298 of the Abrams publication Star Wars Art: Ralph McQuarrie. The paper exhibits a fold line and crinkling throughout. Dimensions: 17" x 13" (43.25 cm x 33 cm) Sold without copyright; see notice in the Buyer's Guide.

**Estimate: \$4,000 - 8,000**



**1338**  
 Charles Lippincott Collection: Haslab Jabba's Sail Barge  
 (Khetanna) Toy – Sealed  
**Star Wars: Episode VI – Return Of The Jedi (1983)**

A sealed Jabba's Sail Barge (Khetanna) toy produced by Hasbro's HasLab crowd-sourcing program based on Richard Marquand's Star Wars: Return of the Jedi. Released in 2019, this ornately detailed vehicle comes from the collection of longtime Lucasfilm publicist Charles "Charley" Lippincott. It remains sealed inside its original shipping box along with its original box, Jabba the Hutt figure, and Yak Face figure. The shipping box exhibits scuffing and punctures on the sides from age and handling. Dimensions: 18" x 53.5" x 18" (45.75 cm x 136 cm x 45.75 cm)

**Estimate: \$1,500 - 3,000**

**The William Plumb Collection:** See page 335 for an overview of William Plumb



26" (66cm)



**1339**  
 William Plumb Collection: Hand-Painted Star Wars  
 Monthly No. 166 Cover Artwork  
**Marvel Comics**

Cover artwork hand-painted by John Higgins for Star Wars Monthly no. 166 published February 1983 in the UK by Marvel Comics. The issue was written by David Michelinie with pencils by Walt Simonson, inks by Tom Palmer, and letters by Janice Chiang. This painting of Luke Skywalker surrounded by TIE fighters and X-wing starfighters comes from the personal collection of William Plumb. It is rendered in mixed media on washboard. The artwork was later reused on the back of Star Wars Galaxy Series 2 card no. 158. Also included is a letter about the painting written by Higgins circa 1993 and a copy of Star Wars Monthly no. 166. This lot exhibits minor edge wear throughout. Dimensions: 26" x 20" x 3" (66 cm x 51 cm x 7.75 cm) Sold without copyright; see notice in the Buyer's Guide.

**Estimate: \$3,000 - 6,000**



**1340**  
 William Plumb Collection: Set of Three Hand-Painted  
 Star Wars Comic Book Color Guides  
**Star Wars: Episode IV – A New Hope (1977)**

A set of three hand-painted Star Wars comic book color guides from George Lucas' Star Wars: A New Hope. Color guides are resized hand-colored copies of original inked and drawn artworks for use as a color reference for mass publication. This lot consists of three comic strip pages, each hand-painted with two featuring a vellum page cover with handwritten annotations in black ink for coloring guides and one featuring handwritten annotations throughout. These comic strips are labeled "5-4 #61," "#2" and "26" as their issue numbers. #2 was signed by Russ Manning at the 1979 San Diego Comic-Con. This lot exhibits discoloration and tape grime. Dimensions: 15" x 10.75" (38.25 cm x 27.5 cm) Sold without copyright; see notice in the Buyer's Guide.

**Estimate: \$1,000 - 2,000**



**1341**  
 William Plumb Collection: Set of Hand-Drawn Luke Skywalker's Activity Book Character and Vehicle Sketches  
**Star Wars: Episode IV - A New Hope (1977)**

Character and vehicle sketches hand-drawn by illustrator Patricia Wynne for James Razzi's children's coloring book Luke Skywalker's Activity Book. Random House published the book as a merchandising tie-in with George Lucas' Star Wars: A New Hope in 1979. This set comes from the personal collection of William Plumb. It consists of eight sketches depicting Luke in Jedi training, X-wings, TIE Fighters, and various Tatooine characters rendered in graphite and applied throughout with printed paper cut-outs. Also included is a copy of Luke Skywalker's Activity Book. The sketches are unevenly cut and exhibit staining throughout, and the book exhibits edge wear from age. Dimensions: (largest) 9" x 10" (23 cm x 25.5 cm) Sold without copyright; see notice in the Buyer's Guide.

**Estimate: \$1,000 - 2,000**



**1342**  
 William Plumb Collection: Set of Hand-Drawn Darth Vader's Activity Book Sketches  
**Star Wars: Episode IV - A New Hope (1977)**

Character and vehicle sketches hand-drawn by illustrator Patricia Wynne for James Razzi's children's coloring book Darth Vader's Activity Book. Random House published the book as a merchandising tie-in with George Lucas' Star Wars: A New Hope in 1979. This set comes from the personal collection of William Plumb. It consists of eight sketches depicting Darth Vader, Obi-Wan Kenobi, Stormtroopers, and various activities from the book rendered in graphite and applied throughout with printed paper cut-outs. Also included is a copy of Darth Vader's Activity Book. The sketches are unevenly cut and exhibit staining throughout, including intentional paint finish applied to their reverses. Dimensions: (largest) 15" x 12" (38.25 cm x 30.5 cm) Sold without copyright; see notice in the Buyer's Guide.

**Estimate: \$1,200 - 2,400**

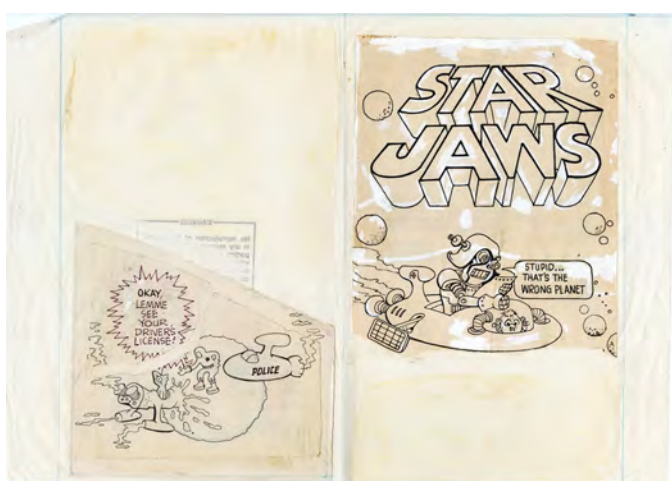

**1343**  
 William Plumb Collection: Pair of Hand-Drawn Will Eisner Cover Artworks with Autographed Edition  
**Star Jaws (1978)**

Two cover artworks hand-drawn by comic artist Will Eisner with an autographed copy of his parody graphic novel Star Jaws. Eisner published his collection of one-page "gags" that mashed up characters from Jaws and Star Wars in 1978. This lot comes from the personal collection of William Plumb. It consists of two Star Jaws cover artworks headlined "Star Jaws" and "A Galaxy of Space Cartoons" rendered in mixed media on paper; a copy of the collection signed "To Bill" in gold ink by Eisner; a letter from Eisner to Plumb about Star Jaws dated 1989; and a color-printed picture of Eisner. The artworks exhibit discoloration and correction fluid stains. Dimensions: (largest) 9" x 10" (23 cm x 25.5 cm) Sold without copyright; see notice in the Buyer's Guide.

**Estimate: \$1,500 - 3,000**

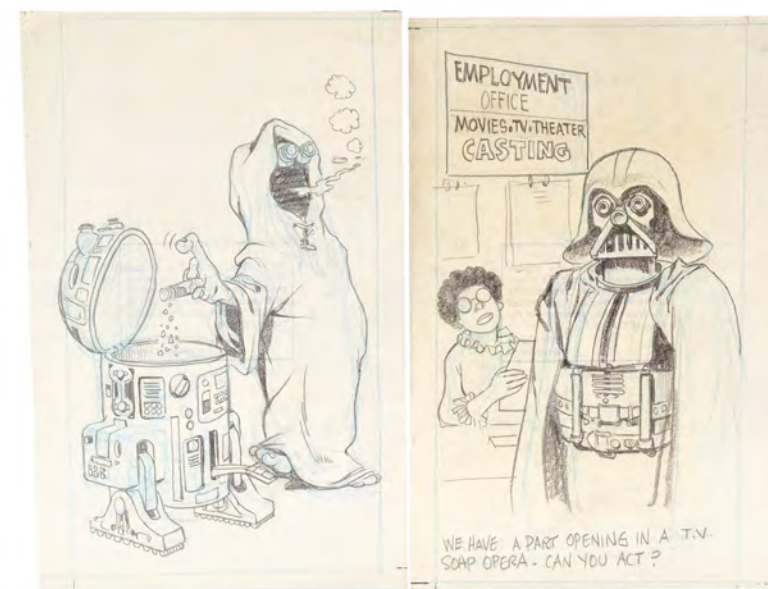

**1344**  
 William Plumb Collection: Pair of Hand-Drawn Will Eisner Comic Page Interior Sketches  
**Star Wars: Episode V - The Empire Strikes Back (1978)**

A pair of hand-drawn Will Eisner comic page interior sketches from Will Eisner's parody graphic novel Star Wars. Cartoonist Eisner, assisted by Keith Diaczun and Barry Caldwell, published a collection of one-page "gags" that featured Star Wars characters. This lot comes from the personal collection of William Plumb. Hand-rendered in blue pencil and graphite, these two pages feature Darth Vader as a hiring middle manager, and a Jawa using R2-D2 as an ashtray. These sketches correspond to pages 33 and 25 of the novel. This lot exhibits some discoloration from age. Dimensions: (each) 14" x 12" (35.5 cm x 30.5 cm) Sold without copyright; see notice in the Buyer's Guide.

**Estimate: \$800 - 1,600**



**1345**  
 William Plumb Collection: Hand-Drawn Pop-Up Book Production Artwork  
**Star Wars: Episode V - The Empire Strikes Back (1980)**

Artwork hand-drawn by illustrator Patricia Wynne for the production of Star Wars: The Empire Strikes Back: A Pop-Up Book, a children's book published by Random House and Lucasfilm in conjunction with the theatrical release of ESB in 1980. This set of three large and three small artworks depicting Luke on Hoth, Dagobah, and Cloud City with Darth Vader comes from the personal collection of William Plumb. The artwork is rendered in mixed media on illustration board and hand-cut paper. Also included is a July 1979 letter about the book from Lucasfilm printed on Black Falcon stationery. The paper is unevenly cut and the artworks exhibit staining throughout. Dimensions: (largest) 12" x 15" (30.5 cm x 38.25 cm) Sold without copyright; see notice in the Buyer's Guide.

**Estimate: \$1,000 - 2,000**

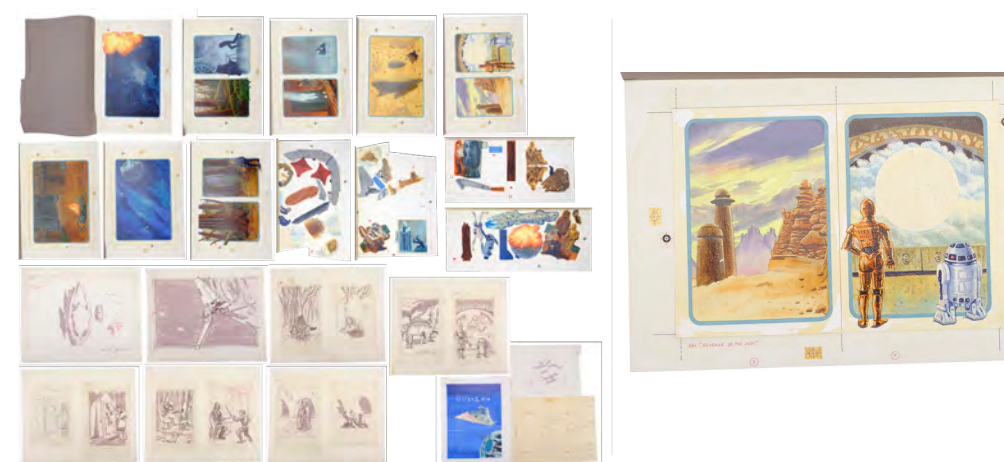

**1346**  
 William Plumb Collection: Hand-Drawn Pop-Up Book Production Artwork  
**Star Wars: Episode VI - Return Of The Jedi (1983)**

Artwork hand-drawn by illustrator John Gampert for the production of Star Wars: Return of the Jedi: A Pop-Up Book, a children's book published by Random House and Lucasfilm in conjunction with the theatrical release of ROTJ in 1983. This mixed media artwork comes from William Plumb's personal collection. It consists of five hand-drawn, annotated interior book pages; three annotated concept sketches; a cover concept drawing; a jacket layout; and 11 collaged illustration boards. This lot exhibits discoloration, loose illustration boards, and tearing. Dimensions: (largest) 10.25" x 21" (26 cm x 53.5 cm) Sold without copyright; see notice in the Buyer's Guide.

**Estimate: \$2,000 - 4,000**



**1347**  
William Plumb Collection: Set of Four Hand-Illustrated Random House Heroes Bookmark Artworks  
**Star Wars: Episode VI - Return Of The Jedi (1983)**

Four bookmark artworks hand-illustrated by artist Patricia Wynne for Richard Marquand's Star Wars: Return of the Jedi. Random House distributed bookmarks to promote its release. These cardstock bookmarks, from William Plumb's personal collection, depict Leia Organa, Han Solo, Luke Skywalker, and Obi-Wan Kenobi in mixed media with colorful backgrounds. Also included are original 1983 bookmarks for each character, with production notes for three of the four. The artworks' backs, "Luke," and "Leia" exhibit staining, residue, and corner wear. Dimensions: (each) 7.25" x 2.5" (18.5 cm x 6.5 cm) Sold without copyright; see notice in the Buyer's Guide.

**Estimate: \$2,000 - 4,000**



**1348**  
William Plumb Collection: Set of Four Hand-Illustrated Random House Villains Bookmark Artworks  
**Star Wars: Episode VI - Return Of The Jedi (1983)**

Four bookmark artworks hand-illustrated by artist Patricia Wynne for Richard Marquand's Star Wars: Return of the Jedi. Random House distributed bookmarks to promote its release. These cardstock bookmarks, from William Plumb's personal collection, depict Darth Vader, a stormtrooper, Boba Fett, and a royal guard in mixed media with colorful backgrounds. Also included are original 1983 bookmarks for each character and a style guide reference sheet for the Royal Guard. The artworks' backs exhibit staining, and "Darth Vader" exhibits edge staining. Dimensions: (each) 7.25" x 2.5" (18.5 cm x 6.5 cm) Sold without copyright; see notice in the Buyer's Guide.

**Estimate: \$2,000 - 4,000**



**1349**  
William Plumb Collection: Set of Four Hand-Illustrated Random House Character Bookmark Artworks  
**Star Wars: Episode VI - Return Of The Jedi (1983)**

Four bookmark artworks hand-illustrated by artist Patricia Wynne for Richard Marquand's Star Wars: Return of the Jedi. Random House distributed bookmarks to promote its release. These cardstock bookmarks, from William Plumb's personal collection, depict Jabba the Hutt with Salacious Crumb, Lando Calrissian, Wicket, and Admiral Ackbar in mixed media with colorful backgrounds. Also included are original 1983 bookmarks for each character, with production notes for three of the four. The artworks' backs exhibit staining with "Jabba" exhibiting tearing and white tape. Dimensions: (each) 7.25" x 2.5" (18.5 cm x 6.5 cm) Sold without copyright; see notice in the Buyer's Guide.

**Estimate: \$2,000 - 4,000**

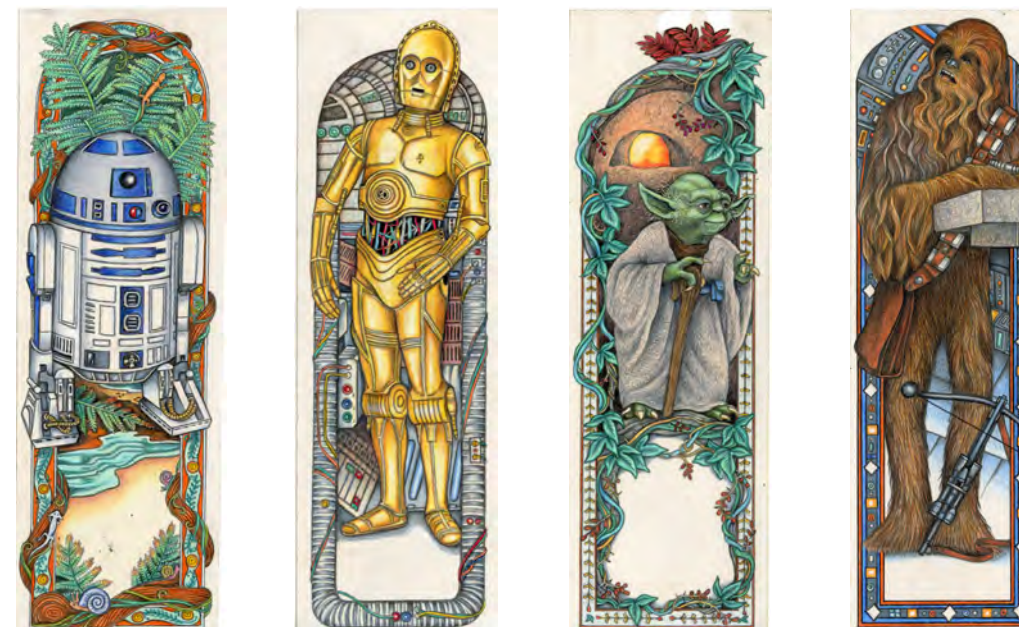

**1350**  
William Plumb Collection: Set of Four Hand-Illustrated Random House Character Bookmark Artworks  
**Star Wars: Episode VI - Return Of The Jedi (1983)**

Four bookmark artworks hand-illustrated by artist Patricia Wynne for Richard Marquand's Star Wars: Return of the Jedi. Random House distributed bookmarks to promote its release. These cardstock bookmarks, from William Plumb's personal collection, depict R2-D2, C-3PO, Yoda, and Chewbacca in mixed media with colorful backgrounds. Also included are original 1983 bookmarks for each character, with production notes for two of the four. The artworks' backs exhibit staining. Dimensions: (each) 7.25" x 2.5" (18.5 cm x 6.5 cm) Sold without copyright; see notice in the Buyer's Guide.

**Estimate: \$2,000 - 4,000**



**1351**  
William Plumb Collection: Hand-Drawn ABC Readiness Workbook Cover and Interior Artwork  
**Star Wars: Episode VI - Return Of The Jedi (1983)**

Cover and interior artwork hand-drawn by illustrator Ken Barr for Judith Conaway's Star Wars: Return of the Jedi: ABC Readiness: A Kindergarten Workbook, released by Happy House Books in 1983. This lot consists of eight illustration boards rendered in black ink with annotations and three covered with tracing paper; an R2-D2 silhouette completed word search; a hand-painted cover illustration on illustration board; and a 48-page copy of the Workbook in an acrylic sleeve. This lot exhibits discoloration and minor grime. Dimensions: (largest) 18" x 22.5" (45.75 cm x 57.25 cm) Sold without copyright; see notice in the Buyer's Guide.

**Estimate: \$1,200 - 2,400**



**1352**  
William Plumb Collection: Hand-Painted C-3PO's Book About Robots Artwork  
**Star Wars: Various Productions**

Hand-painted artwork by John Gampert for Star Wars: C-3PO's Book About Robotics. Random House published the book in 1983 in conjunction with the theatrical release of the film. This lot comes from William Plumb's personal collection. The six hand-painted illustrations, three sketches, and one 32-page mini booklet, feature hand-marked annotations in red and black ink. This lot exhibits some edge warping. Dimensions: 29" x 24" (73.75 cm x 61 cm) Sold without copyright; see notice in the Buyer's Guide.

**Estimate: \$2,000 - 4,000**

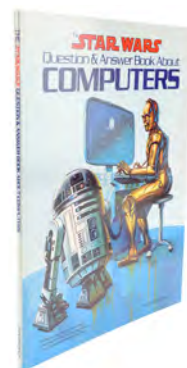

**1353**  
William Plumb Collection: Hand-Painted Questions & Answer Book About Computers Cover Artwork  
**Star Wars: Various Productions**

Cover artwork hand-painted by Ken Barr for Fred D'Ignazio's The Star Wars Question & Answer Book About Computers, and a copy of the book. Random House published the book in 1983 in conjunction with the theatrical release of the film. This lot comes from William Plumb's personal collection. It consists of one illustration featuring C-3PO and Barr's signature rendered in mixed media on paper and one 61-page book. The artwork exhibits mild edgewear. Dimensions: 30" x 23" x 2" (76.25 cm x 61 cm x 5 cm) Sold without copyright; see notice in the Buyer's Guide.

**Estimate: \$1,200 - 2,400**

**1354**  
William Plumb Collection: Set of Hand-Painted Question & Answer Book About Computers Interior Page Illustrations  
**Star Wars: Various Productions**

Interior page illustrations hand-painted by Kenn Barr for Fred D'Ignazio's The Star Wars Question & Answer Book About Computers, and a copy of the book. Random House published the book in 1983 in conjunction with the film's release. These 19 illustrations of C-3PO and R2-D2 engaging with various electronics come from William Plumb's personal collection. They are rendered in mixed media on paper hand-marked with page numbers and other information for publishing purposes. This lot exhibits minor discoloration. Dimensions: (each) 14" x 12" (35.5 cm x 30.5 cm) Sold without copyright; see notice in the Buyer's Guide.

**Estimate: \$2,000 - 4,000**



**1355**  
William Plumb Collection: Hand-Drawn Tim Hildebrandt Ewok Adventure Video Game Cover Concept Sketch  
**Star Wars: Episode VI - Return Of The Jedi (1983)**

A concept sketch hand-drawn by Tim Hildebrandt for the cover of Atari's unreleased Return of the Jedi tie-in video game Ewok Adventure. This sketch features schematic illustrations. The film was not finalized at the time of drawing. This sketch depicting a hang-gliding Ewok and AT-ST comes from William Plumb's personal collection. It is rendered and signed by Hildebrandt in graphite on vellum. Included is a trading card of the cover and a photograph of the sketch. The sketch exhibits corner tearing and discoloration from age. Dimensions: 30" x 25" (76.25 cm x 63.5 cm) Sold without copyright; see notice in the Buyer's Guide.

**Estimate: \$1,200 - 2,400**



**1356**  
William Plumb Collection: Hand-Drawn Word Puzzles Book Illustrations  
**Star Wars: Original Trilogy (1977-1983)**

Hand-drawn illustrations by Ken Barr for Linda Quinton's children's book Star Wars Word Puzzles. Random House published the booklet, a collection of word games based on the original Star Wars trilogy, in 1984. This lot comes from the personal collection of William Plumb. It consists of 29 illustrations rendered in black ink on illustration boards covered with taped vellum featuring handwritten annotations. Also included is a Star Wars Word Puzzles booklet. This lot exhibits minor discoloration and minor stains on the booklet. Dimensions: (largest) 10" x 11" (25.5 cm x 28 cm) Sold without copyright; see notice in the Buyer's Guide.

**Estimate: \$2,000 - 4,000**

**1357**  
William Plumb Collection: 1978 Hand-Painted Dave Dorman Han and Chewy Portfolio Painting  
**Star Wars: Various Productions**

A Han Solo and Chewbacca painting hand-painted by Star Wars artist Dave Dorman. Created as a portfolio piece circa 1978, this painting featuring Han and Chewy in front of the Millennium Falcon was among Dorman's first-ever Star Wars paintings, and preceded his work as an acclaimed illustrator for Star Wars-related books, comics, and magazines. The oil painting rendered on canvas board comes from the personal collection of William Plumb. Also included are two letters from Dorman to Plumb. The canvas exhibits minor staining and edge wear. Dimensions: 26" x 20" x 1" (66.25 cm x 51 cm x 2.5 cm) Sold without copyright; see notice in the Buyer's Guide.

**Estimate: \$2,500 - 5,000**



**1358**  
William Plumb Collection: Hand-Painted Ewok Adventure Book Production Artwork  
**Star Wars: Episode VI - Return Of The Jedi (1983)**

Production artwork hand-painted by illustrator Pat Paris for Melinda Luke's Wicket Finds a Way: An Ewok Adventure, a children's book released in conjunction with Star Wars: Return of the Jedi. This lot comes from William Plumb's personal collection. It consists of 15 hand-painted illustrations on illustration bristol board featuring handwritten annotations; 14 sketches rendered in ink on tracing paper; and a 16-page Wicket Finds a Way: An Ewok Adventure children's book in an acrylic sleeve This lot exhibits minor stains. Dimensions: 8" x 10" (20.5 cm x 25.5 cm) Sold without copyright; see notice in the Buyer's Guide.

**Estimate: \$2,000 - 4,000**



26.5" (67.5cm)



**1359**  
 William Plumb Collection: Matted Hand-Drawn Ewok Poster Prelim  
**Star Wars: Various Productions**

A matted prelim for an Ewok poster hand-drawn by Pat Paris. Paris illustrated Ewok-themed posters and children's books for various Lucasfilm projects, including The Baby Ewoks' Picnic Surprise. This prelim headlined "Friends Come In All Shapes And Sizes" comes from William Plumb's personal collection. It is rendered and signed in pencil on paper, applied with cut-outs, and framed behind plastic with rust-color mat board. The lot exhibits eraser marks and stains to the mat board. Dimensions: 26.5" x 22" x 0.5" (67.5 cm x 56 cm x 1.5 cm) Sold without copyright; see notice in the Buyer's Guide.

**Estimate: \$1,500 - 3,000**



**1360**  
 William Plumb Collection: Matted Hand-Painted Ewok Artwork  
**Star Wars: Various Productions**

Matted Ewok artwork hand-drawn by Pat Paris. Paris illustrated Ewok-themed posters and children's books for various Lucasfilm projects, including The Baby Ewoks' Picnic Surprise. This art piece was later printed as a Spanish sticker. This artwork depicting two Ewoks comes from the personal collection of William Plumb. It is hand-painted on paper and mounted within an orange-colored mat with a clear sleeve to protect the illustration, Paris' signature, and a "Pat Paris Productions" stamp on the back. This lot exhibits minor bent corners and the illustration is susceptible to moving in the mat. Dimensions: 14.75" x 15.25" (37.5 cm x 38.75 cm) Sold without copyright; see notice in the Buyer's Guide.

**Estimate: \$1,500 - 3,000**

**1361**  
 William Plumb Collection: Pair of Hand-Drawn Poster Prelims  
**EWOKS: THE BATTLE FOR ENDOR (1985)**

Two hand-drawn poster prelims for Jim and Ken Wheat's sci-fi TV movie Ewoks: The Battle for Endor. Both prelims depict Cindel (Aubree Miller), Noa (Wilford Brimley), and Wicket (Warwick Davis) with Charal (Sian Phillips) featured in only one. These sketches come from the personal collection of William Plumb. Each is rendered in graphite on vellum taped to bordered paper. Also included are two color-printed poster proofs for Caravan of Courage: An Ewok Adventure labeled for illustrator Kazuhiko Sano. This lot exhibits discoloration and minor rips and fraying along the edges. Dimensions: 24" x 19" (61 cm x 48.25 cm) Sold without copyright; see notice in the Buyer's Guide.

**Estimate: \$2,500 - 5,000**

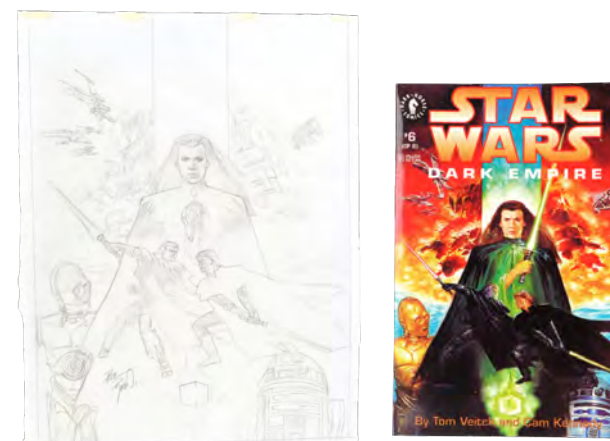

**1362**  
 William Plumb Collection: Matted Hand-Painted Dave Dorman Star Wars: Dark Empire No. 6 Cover Sketch  
**Dark Horse Comics**

A matted sketch hand-drawn by artist Dave Dorman for the cover of Star Wars: Dark Empire no. 6, published by Dark Horse Comics with an October 1992 cover date. This sketch depicting Luke Skywalker, Emperor Palpatine, and a lightsaber-wielding Leia Organa comes from the personal collection of William Plumb. It is rendered and signed by Dorman in graphite on paper and matted with marbled gray board along with a copy of the Dark Empire No. 6 cover. It exhibits eraser marks and the board exhibits staining. Dimensions: 26" x 21" x 0.5" (66 cm x 53.5 cm x 1.5 cm) Sold without copyright; see notice in the Buyer's Guide.

**Estimate: \$800 - 1,600**



**1364**  
 William Plumb Collection: Framed Pair of Hand-Drawn Lawrence Noble Darth Vader Bronze Statue Concept Sketches  
**Lucasfilm**

Two framed concept sketches for a Darth Vader bronze statue hand-drawn by Star Wars artist Lawrence Noble. These sketches depicting front and side views of a Vader statue come from William Plumb's personal collection. Both are rendered and signed by Noble in mixed media on paper stamped with the Noble Studio insignia and mounted behind glass in a black board-backed frame. They exhibit smudging and minor creasing. Dimensions: 47" x 26" x 3" (119.5 cm x 66.25 cm x 7.75 cm) Sold without copyright; see notice in the Buyer's Guide.

**Estimate: \$800 - 1,600**



**1363**  
 William Plumb Collection: Set of Three Lawrence Noble Ewok Statues  
**Star Wars: Episode VI - Return Of The Jedi (1983)**

Three Lawrence Noble Ewok statues from Richard Marquand's Star Wars: Return of the Jedi. Noble created these statues after the film release. This lot comes from the personal collection of William Plumb. It consists of one Ewok carved wax statue with a wooden staff on a brown resin base; one artist proof cold cast statue; and one bronze Ewok statue mounted on a stone and wooden base with a gold-color metal plaque. The wax and artist proof statues are signed by Noble. This lot exhibits a broken hand and staffs and bent staff on the bronze statue. Dimensions: 10.5" x 5" x 5" (26.75 cm x 12.75 cm x 12.75 cm)

**Estimate: \$2,000 - 4,000**



**1365**  
 William Plumb Collection: Framed Limited-Edition Drew Struzan "America's Movies for the World's Athletes" Poster Artwork Print  
**1984 Summer Olympics**

A framed limited-edition print designed by Drew Struzan for competing athlete poster gifts at the 1984 XXIII Olympic Games in Los Angeles. Produced by Struzan, Jane Firstenburg, and Steven Spielberg, the "America's Movies for the World's Athletes" posters depicted iconic characters from cinema, including Charles Foster Kane, E.T., and Darth Vader. This glossy, signed, limited-edition print comes from William Plumb's personal collection. Numbered "18/20," it comes mounted behind glass in a brown wooden frame. They exhibit minor edge wear. Dimensions: 31" x 29" x 1" (78.75 cm x 73.75 cm x 2.5 cm)

**Estimate: \$1,000 - 2,000**





**1366**  
 William Plumb Collection: Hand-Drawn  
 Ralph McQuarrie Concept Sketches  
 Isaac Asimov's Inferno

Hand-drawn Ralph McQuarrie concept sketches from Roger MacBride Allen's robot novel Isaac Asimov's Inferno. McQuarrie created various sketches for the cover of Allen's book featuring Asimov's robots. This lot comes from the personal collection of William Plumb. It consists of four prints of the cover, the artwork, and sketches with handwritten annotations; a cover proof with McQuarrie's hand-drawn "Inferno" secured to the front; and a hand-drawn robot with "Inferno" on tracing paper secured over white paper. This lot exhibits minor wrinkling and discoloration. Dimensions: 17" x 11" (43.25 cm x 28 cm) Sold without copyright; see notice in the Buyer's Guide.

**Estimate: \$800 - 1,600**



**1367**  
 William Plumb Collection: Hand-Drawn  
 Ralph McQuarrie Preliminary  
 Concept Sketches  
 Robot Visions (1990)

Hand-drawn Ralph McQuarrie preliminary concept sketches from Isaac Asimov's Robot Visions. McQuarrie created various sketches for the cover of Asimov's book which were later used for Roger MacBride Allen's robot novel Isaac Asimov's Inferno. This lot comes from the personal collection of William Plumb. It consists of one page of hand-drawn thumbnail sketches rendered in graphite and color; and a hand-drawn robot with outstretched arms on tracing paper secured over white paper. This lot exhibits minor wrinkling and discoloration. Dimensions: 17" x 11" (43.25 cm x 28 cm) Sold without copyright; see notice in the Buyer's Guide.

**Estimate: \$1,500 - 3,000**

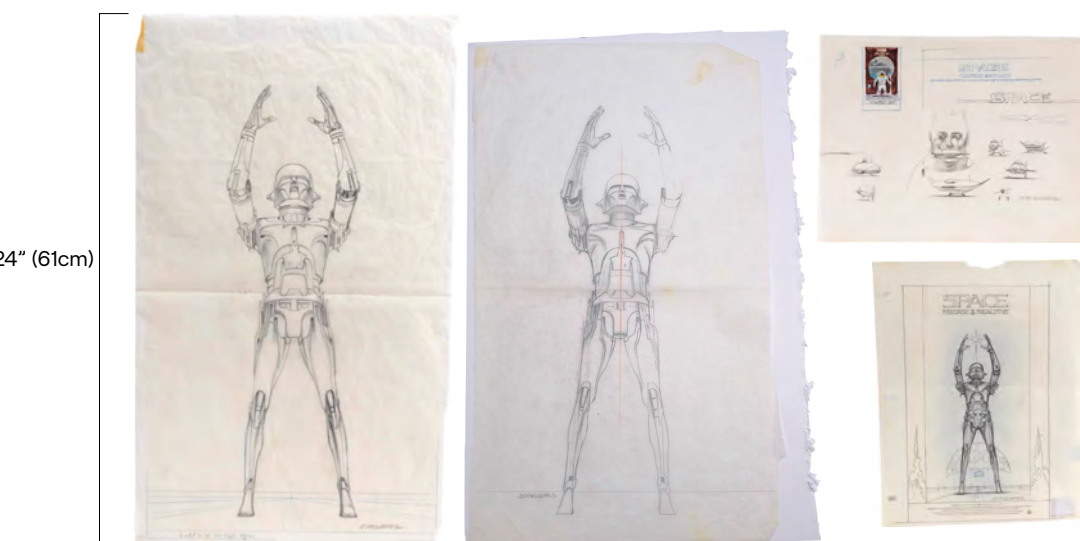

24" (61cm)

**1368**  
 William Plumb Collection: Hand-Drawn  
 Ralph McQuarrie "Space: Fantasy and  
 Reality" Poster Concept Sketches  
 Space: Fantasy And Reality

Hand-drawn poster concept sketches by Ralph McQuarrie promoting the Space: Fantasy & Reality art expo. William Plumb brought revered artists McQuarrie, Drew Struzan, and Lawrence Noble to the fundraiser at the Maturango Museum in 1986. This set from Plumb's personal collection consists of five robot sketches and one thumbnail sketch page labeled "Space: Fantasy & Reality," including a head resembling unmasked Darth Vader in Star Wars: Return of the Jedi rendered and signed by McQuarrie in graphite with mixed media touch-ups on vellum and paper. The vellum exhibits tears and edge stains. Dimensions: (largest) 24" x 16" (61 cm x 40.75 cm) Sold without copyright; see notice in the Buyer's Guide.

**Estimate: \$1,000 - 2,000**



**1369**  
 John Dykstra-Autographed 3D-Printed Luke Skywalker  
 Prototype Lightsaber Hilt  
 Star Wars: The Complete Saga

A 3D-printed prototype of Luke Skywalker's (Mark Hamill) lightsaber hilt as seen in George Lucas' Star Wars saga autographed by Industrial Light & Magic (ILM) co-founder and A New Hope lead SFX designer John Dykstra. Based on a prototype design made during production on the original trilogy, this gray 3D-printed resin lightsaber hilt is one of only 250 created circa 2015 as a promotional item for donors to Omaze/Make-A-Wish Foundation. Dykstra's signature is rendered in black marker. The piece exhibits some fractures in the resin. Dimensions: 12" x 3" x 3 (30.5 cm x 7.75 cm x 7.75 cm)

**Estimate: \$1,000 - 2,000**

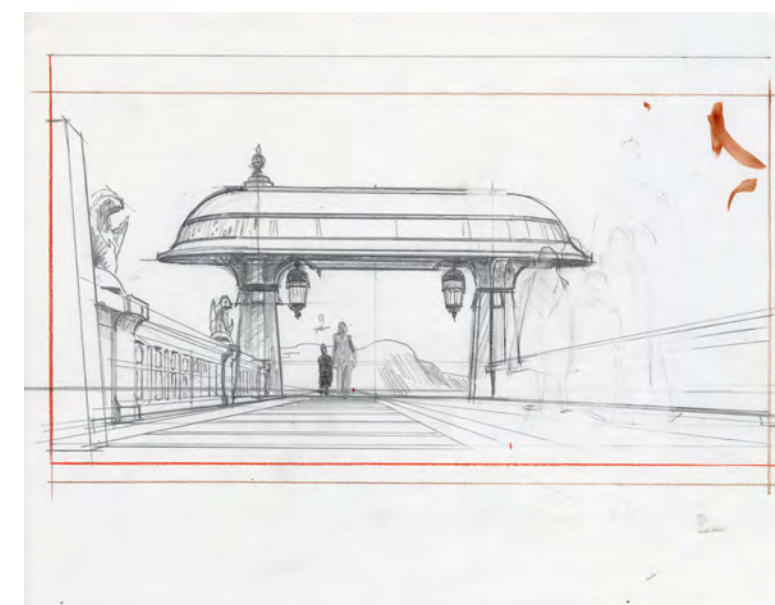

**1370**  
 Hand-Drawn Ralph McQuarrie Jabba's Palace Gate  
 Concept Sketch  
 The Illustrated Star Wars Universe (1995)

A concept sketch of Jabba the Hutt's Tatooine palace gate hand-drawn by Ralph McQuarrie for Kevin J. Anderson's book The Illustrated Star Wars Universe. Considered the foremost artist from the franchise, McQuarrie contributed art for the book. Select McQuarrie illustrations were developed during production on the original trilogy, with designs for Jabba's palace gate first seen in Return of the Jedi-era artworks. The gate was later used as a key set piece in J.J. Abrams' The Force Awakens. This sketch is rendered in graphite on paper with a red pencil border. It exhibits folded corners and a paint color test in the top right corner. Dimensions: 8.5" x 11" (21.75 cm x 28 cm) Sold without copyright; see notice in the Buyer's Guide.

**Estimate: \$5,000 - 10,000**

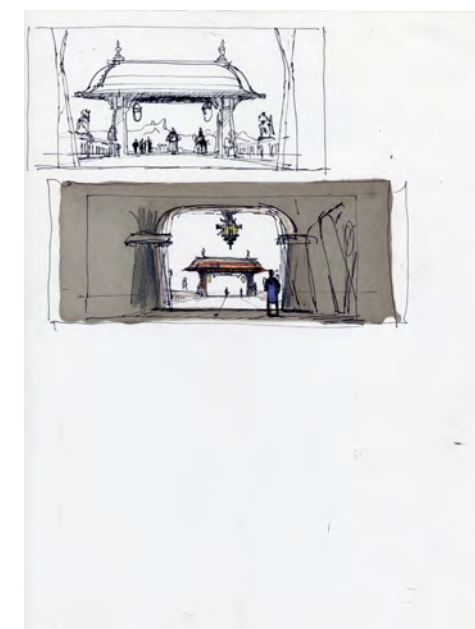

**1371**  
 Hand-Drawn Ralph McQuarrie "Jabba's Palace North  
 Gate Bridge" Thumbnail Sketches for Illustration  
 The Illustrated Star Wars Universe (1995)

Thumbnail sketches of the north gate bridge leading to Jabba the Hutt's Tatooine palace hand-drawn by Star Wars artist Ralph McQuarrie for Kevin J. Anderson's book The Illustrated Star Wars Universe. Select McQuarrie illustrations were developed during production on the original trilogy, with designs for Jabba's north gate first seen in Return of the Jedi-era artworks. These two preliminary sketches were also featured on page 298 of the Abrams publication Star Wars Art: Ralph McQuarrie, with the gate later used as a key set piece in J.J. Abrams' The Force Awakens. Thumbnails are rendered in ink and marker on illustration paper. The paper exhibits smudges and stains. Dimensions: 8.5" x 11" (21.75 cm x 28 cm) Sold without copyright; see notice in the Buyer's Guide.

**Estimate: \$1,500 - 3,000**



**1372**  
Hand-Drawn Lawrence Noble Rey Sculpture Study  
**Star Wars: Episode VII - The Force Awakens (2015)**

A sculpture study of Rey (Daisy Ridley) from J.J. Abrams' Star Wars: The Force Awakens hand-drawn by Star Wars artist Lawrence Noble for a proposal to Lucasfilm. Noble also designed the Yoda statue in Lucasfilm's courtyard, though the sculpture in this study was ultimately not produced. This study depicting Rey with her quarterstaff before a scale is rendered in graphite on thick art paper hand-marked "Star Wars Episode VII Sculpture Study Drawing No. 4 Rey 24' Figure," dated "9-10-15," signed by Noble, and stamped with his studio's seal. The paper exhibits edge wear and smudge marks in the margins. Dimensions: 18" x 12" (45.75 cm x 30.5 cm) Sold without copyright; see copyright notice in the Buyer's Guide.

**Estimate: \$1,200 - 2,400**



**1374**  
First Order Dreadnought Model with Promotional  
Ephemera  
**Star Wars: Episode VIII - The Last Jedi (2017)**

A First Order Dreadnought model with promotional ephemera for Rian Johnson's Star Wars: The Last Jedi. These were given out at the film's premiere to promote an augmented reality experience presented by Topps and Verizon. This lot includes a resin model painted gray with a weighted black resin display stand and armature; a stapled, 6-page "Star Destroyer 360" AR Experience Guide"; a printed model assembly instruction page; two AR instructional cards; and one paper mat with an outline for the model's base placement. The ephemera exhibits minor edge wear; the model exhibits minor scuffing from storage. Dimensions: 18" x 8.5" x 7.5" (45.75 cm x 21.75 cm x 19 cm)

**Estimate: \$800 - 1,600**



**1373**  
Cast-Autographed Sealed Blu-Ray DVD  
**Star Wars: Episode VII - The Force Awakens (2015)**

A cast-autographed sealed Blu-Ray DVD from J.J. Abrams' Star Wars: The Force Awakens. The cast autographed the film's digital versatile disk shortly after its release. This sealed Blu-Ray DVD is autographed by Mark Hamill, Carrie Fisher, Daisy Ridley, John Boyega, Oscar Isaac, and Adam Driver on the DVD's cardboard sleeve in silver-color marker. Included is a Letter of Authenticity signed by Lucasfilm Ltd. President Kathleen Kennedy on Lucasfilm Ltd. letterhead and dated May 4, 2016. This lot exhibits minor tears to the sleeve from age and handling. Dimensions: 5.5" x 6.75" x 0.5" (14 cm x 17.25 cm x 1.5 cm)

**Estimate: \$800 - 1,600**



**1375**  
Col. Jack O'Neil's (Kurt  
Russell) Costume  
**Stargate (1994)**

Col. Jack O'Neil's (Kurt Russell) costume from Roland Emmerich's sci-fi adventure Stargate. O'Neil wore his costume as he led military specialists through an ancient portal to a planet on the other side of the galaxy, culminating in a fight with Anubis (Carlos Lauchu). This lot consists of a black T-shirt hand-marked "#1 Kurt" on the tag with a snap-fastened strap between the legs to keep the shirt tucked in; green button-fly cargo trousers hand-marked "ONEIL," and a black woven nylon belt with a metal buckle. The costume exhibits some light staining and the marking on the T-shirt is very faded.

**Estimate:**  
**\$2,000 - 4,000**



**1376**  
Light-Up Jaffa Serpent Guard  
Helmet  
**Stargate SG-1 (1997-2007)**

A light-up Jaffa serpent guard helmet from the sci-fi series Stargate SG-1. Genetically-engineered Jaffa warriors wore their signature serpent helmets throughout the series. This ornately detailed headpiece is constructed from padded and etched dense rubber molded around a plastic helmet, inset with two resin faux ruby eyes, and taped with wood backing and a battery pack. The two 9V batteries power internal lights which illuminate the eyes when activated. The helmet is hand-marked "3" and "Scott" in multiple places on the interior and painted silver-color with gold-color detailing. It exhibits splitting at the neck and flaking paint throughout. Contains electronics; see electronics notice in the Buyer's Guide.

**Estimate: \$3,000 - 6,000**



**1377**  
Adria's (Morena Baccarin) Costume  
with Screen-Matched Choker  
**Stargate: The Ark Of Truth (2008)**

Adria's (Morena Baccarin) costume with a screen-matched choker from Robert C. Cooper's sci-fi adventure Stargate: The Ark of Truth. Adria wore her costume when she revealed herself as an ascended being to Vala (Claudia Black) in the City of Celestis. The choker in this costume screen-matches to when she and Vala sparred about the Ark of Truth. This colorful costume consists of a floor-length orange faux silk dress with chiffon layering and beaded and embroidered embellishments on the skirt; a red polyester bell-sleeved cloak with gold-color yellow and orange lining and beaded details; a multicolor bead choker; a pair of patent terracotta heels (size 7.5 M); and a wardrobe tag. The costume exhibits some loose threads and frayed fabric throughout.

**Estimate: \$3,000 - 6,000**



**1378**  
Tigers Jump Ball Player and  
Cheerleader Costumes  
**Starship Troopers (1997)**

Tigers jump ball player and cheerleader costume from Paul Verhoeven's sci-fi satire Starship Troopers. Cheerleaders encouraged the Tigers when they played jump ball against the Giants. This lot consists of a foam-padded black plastic Tigers-branded ice hockey helmet; a matching Lycra jersey numbered "14"; matching lace-up trousers (size M) with crash pads on the shins and an interior tag labeled "Starship Troopers Jump Ball"; matching sneakers; a black and orange Lycra cheerleading tank-top; and a matching Lycra skirt hand-marked "Sony W." Also included are two replica Tigers gloves and matching replica pom poms added to complete both costumes. They exhibit some loosening Lycra from age and staining throughout from production wear.

**Estimate: \$2,500 - 5,000**



**1379**  
**Morita MK I Rifle**  
**Starship Troopers (1997)**

A Morita MK I rifle from Paul Verhoeven's science fiction film *Starship Troopers*. Federation pilots and mobile infantry officers battled Arachnids with rifles. This detailed fiberglass rifle is painted olive green with black and silver-color detailing and ridging on the barrel, receiver, and magazine. The barrel's tip is made of metal painted black. A black nylon sling is hooked onto a metal shackle on the left side. Components of this rifle, including its flash suppressor, have undergone sympathetic restoration. It exhibits paint flaking, scratches, and loose components. Dimensions: 40" x 11" x 3" (101.5 cm x 25.5 cm x 7.75 cm) Ownership may be restricted in some countries; see replica firearm notice in Buyer's Guide.

**Estimate: \$2,500 - 5,000**



**1380**  
**Hand-Painted Michael Pangrazio**  
**Iraqi Air Base Matte Painting**  
**Steal The Sky (1988)**

An Iraqi air base matte painting hand-painted by Michael Pangrazio for John D. Hancock's war romance *Steal the Sky*. This matte was created for the scene in which Munir Redfa (Ben Cross) walked through the airbase while discussing transferring. This oversize matte painting depicting an Iraqi air base with the majority of the canvas blacked out is rendered in mixed media on a framed glass panel. Its upper right edge is hand-marked "M-76" and "Dotto 118250" is handwritten in yellow marker on the reverse. The painting exhibits scratches and lifted tape. Dimensions: 49.5" x 61" x 1" (125.75 cm x 155 cm x 2.5 cm) Special shipping required; see notice in the Buyer's Guide. Sold without copyright; see copyright notice in the Buyer's Guide.

**Estimate: \$1,500 - 3,000**



**1381**  
**Hand-Painted Michael Pangrazio**  
**Train Station Matte Painting**  
**Steal The Sky (1988)**

A hand-painted Michael Pangrazio train station matte painting from John D. Hancock's war romance film *Steal the Sky*. Helen Mason (Mariel Hemingway) rushed to the train station to stop Munir Redfa's (Ben Cross) family as they planned to go on vacation. This lot consists of one oversize hand-painted matte painting of the inside of a train station with a darkened area along the left platform and an unpainted section at the building's end. The back features tape layers. It exhibits scratches and lifted tape. Dimensions: 49.5" x 61" x 1" (125.75 cm x 155 cm x 2.5 cm) Special shipping required; see notice in the Buyer's Guide. Sold without copyright; see copyright notice in the Buyer's Guide.

**Estimate: \$1,000 - 2,000**



**1382**  
**Sweet Pea's (Abbie Cornish) Light-Up Jetpack**  
**Sucker Punch (2011)**

Sweet Pea's (Abbie Cornish) light-up jetpack from Zack Snyder's action-fantasy film *Sucker Punch*. Rocket (Jena Malone) activated Sweet Pea's jetpack to save her sister from the bomb. This lot consists of a nylon and canvas backpack with an attached resin jetpack. Featuring metal hardware, and rubber nozzles with LED light panels, the strap also has a light-up escape button. It features two hand-marked tape labels on the back for number "2" and "Abbie" in marker. This lot exhibits chipped rubber, scratches to the finish, and mild discoloration. Dimensions: 18" x 11" x 9" (45.75 cm x 28 cm x 22 cm) Contains electronics; see electronics notice in the Buyer's Guide.

**Estimate: \$3,000 - 6,000**



**1383**  
**June Moone's (Cara Delevingne) Spelunking Helmet**  
**Suicide Squad (2016)**

June Moone's (Cara Delevingne) spelunking helmet from David Ayer's superhero film *Suicide Squad*. June wore her helmet on her expedition before she became lost in the caves and found a doll-shaped container that contained the Enchantress' spirit. This lot consists of one helmet with an attached headlight. Composed of a red plastic shell with dark gray inner foam and padding with matching nylon straps and clips, this helmet features "2nd Hero" hand-written in black marker on the inside, and a label hand-marked "DMX 002" in black marker. The headlamp has a battery pack attached to the back of the helmet and is secured in place by a black and gray band. Production intentionally distressed this helmet. This lot exhibits scratches, loose threads, and adhesive residue. Contains electronics; see electronics notice in the Buyer's Guide.

**Estimate: \$1,500 - 3,000**



**1384**  
**Eyes of the Adversary Mask and Arms**  
**Suicide Squad (2016)**

An Eyes of the Adversary mask and arms from David Ayer's superhero film *Suicide Squad*. The Enchantress (Cara Delevingne) transformed Midway City's residents into creatures known as the Eyes of the Adversary for her personal army. This lot consists of one dark gray painted rubber mask and two rubber foam arms that feature numerous sculpted eyes painted a glossy black. This lot exhibits rough seams and very minor holes on the mask. Dimensions (mask): 18" x 10" x 8" (45.75 cm x 25.5 cm x 20.5 cm); (arms): 17" x 7" x 4.5" (43.25 cm x 18 cm x 11.5 cm).

**Estimate: \$1,500 - 3,000**



**1385**  
Starro Spore Background Mask  
**The Suicide Squad (2021)**

A Starro spore background mask from James Gunn's superhero sequel The Suicide Squad. After Starro escaped from imprisonment, it shed spores that latched onto unsuspecting people from Corto Maltese. Designed specifically for background performers, this gray plastic mask features holes for leather cording, a pink and blue starfish pattern with a single eyeball at the center, and "BG024" labeled on the interior. The bottom has been cut and filled with plastic mesh for visibility. The mask exhibits scratches from production and wear, and glue residue on the mesh.

**Estimate: \$2,500 - 5,000**

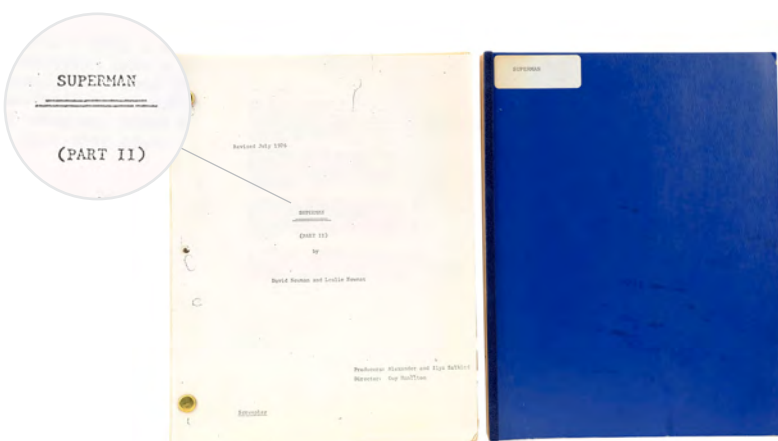

**1387**  
Superman Bound Revised Shooting Script and  
Superman II Bound Revised Screenplay  
**Superman (1978)/Superman II (1980)**

A Superman bound revised shooting script and a Superman II bound revised screenplay from Richard Donner's and Richard Lester's action-adventure films Superman and Superman II. The 142-page Superman bound revised shooting script, dated March 30 and April 6 1977, has printed annotations and a blue plastic cover with a sticker labeled "SUPERMAN." The bound revised screenplay for Superman II is written by David and Leslie Newman, dated July 1976 and is 171 pages in length. This lot exhibits a loose cover for Superman, stains to both, and wrinkles and discoloration to Superman II. Dimensions: (each) 8.5" x 11" x 0.75" (21.75 cm x 28 cm x 2 cm)

**Estimate: \$2,000 - 4,000**



**1386**  
Mole Man Head Appliance  
**Superman And The Mole Men (1951)**

A Mole Man head appliance from Lee Sholem's superhero film Superman and the Mole Men. Superman (George Reeves) encountered a group of Mole Men whose underground dwelling was disturbed by the drilling of the world's deepest oil well. The lot consists of a latex bald cap painted in pink flesh tones with thick brown hair around the sides and back, a black velveteen mannequin display head, and a matching black plaque engraved "Actual Headpiece from the 1951 film, 'Superman and the Mole Men,' starring George Reeves." It is fragile, and exhibits wear from age and production use with scuffing and flaking to the paint, loose hairs, and tearing latex around the appliance's edges. Dimensions: 9" x 8" x 6" (22.75 cm x 20.25 cm x 15.25 cm)

**Estimate: \$2,000 - 4,000**



**1388**  
Framed Hand-Drawn Harry Lange Apollo Module  
Concept Artwork  
**Superman II (1980)**

Apollo module concept artwork hand-drawn by astronautics consultant Harry Lange for the production of Richard Donner's superhero sequel Superman II. General Zod (Terence Stamp) and his minions attacked the Apollo lunar module. This module concept artwork originated from Lange's estate. It is rendered in pen, ink, paint, and pastels on black card signed by Lange and labeled "Superman: Apollo." The artwork comes mounted on tan card behind glass in a cream-color wooden frame hand-marked "SM-16." It exhibits scratching across its center and staining to the frame. Dimensions: 16" x 19" x 2" (40.75 cm x 48.25 cm x 5 cm) Sold without copyright; see notice in the Buyer's Guide.

**Estimate: \$1,000 - 2,000**



**1389**  
Collection of 321 Promotional Slides, Photographs, and  
Press Ephemera  
**Superman II (1980)**

Promotional slides, photographs, and other ephemera from the promotion of Richard Lester's superhero sequel Superman II. Distributed by Warner Bros. to the press, this collection consists of 321 individually numbered film slides contained in plastic slide pages; a press binder with typewritten film credits, biographies, production details, and featurettes; and 16 black-and-white promotional photos with an accompanying typewritten document detailing captions. The ephemera exhibits minor edge wear, discolorations, creasing, and color fading. Dimensions: 10" x 12" x 1" (25.5 cm x 30.5 cm x 2.5 cm)

**Estimate: \$1,000 - 2,000**



**1390**  
Pair of Daily Planet Newspaper Covers  
**Superman (1978)/Superman III (1983)**

Two Daily Planet newspaper covers from Richard Donner and Richard Lester's superhero films Superman and Superman III. In Superman, Otis (Ned Beatty) handed Lex Luthor (Gene Hackman) a Daily Planet regarding upcoming missile tests. Superman (Christopher Reeve) later blew out the Olympic flame while corrupted with bad Kryptonite in a deleted scene from Superman III. This lot consists of two black-and-white, production-made Daily Planet covers, one headlined "Twin Nuclear Missiles Test Confirmed" and one headlined "Superman Extinguishes Flames" alongside a picture of Superman. Additional unrelated stories are printed throughout both covers. They exhibit horizontal fold lines and folded corners from production. Dimensions: 24" x 17" (61 cm x 43.25 cm)

**Estimate: \$1,500 - 3,000**

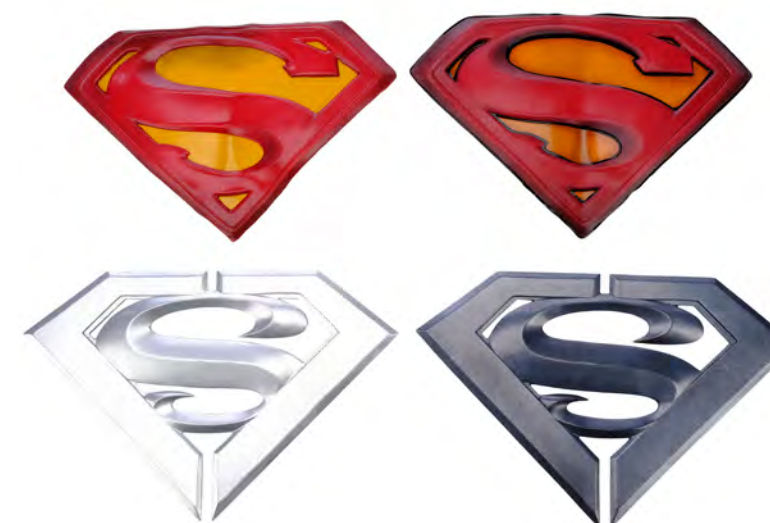

**1391**  
Set of Four Production-Made Chest Emblems  
**Superman Lives (C. 1990S)**

Four production-made chest emblems from Tim Burton's abandoned film Superman Lives. These emblems were made during the film's pre-production phase circa the late 1990s. This lot consists of four emblems, each depicting pectoral muscles and the superhero's signature "S" symbol. The pectoral piece is made of yellow rubber, which has "YS-1" handwritten on the back of one, and the other features a blue strip through the center. The "S" emblems have three different finishes; a bright silver-color, a gunmetal gray color, and red, but one red was shaded to appear darker. The back of the gray emblems feature a piece of tape handmarked Extra Br Alum Blk Bck[sic] 242" and "Gun Metal Blk Bck[sic] 115." Each exhibits residual adhesive worn edges and discoloration. Dimensions: 13" x 9" x 1" (33 cm x 23 cm x 2.5 cm)

**Estimate: \$3,500 - 7,000**



**1392**  
Tom Greer's (Bruce Willis) Light-Up Tranquilizer Gun  
**Surrogates (2009)**

Tom Greer's (Bruce Willis) light-up tranquilizer gun from Jonathan Mostow's sci-fi action film Surrogates. Greer pursued Miles Strickland (Jack Noseworthy) with his tranquilizer gun. This lot consists of a metal and rubber air rifle equipped with a light-up laser sight; a foam-lined metal case with two keys; three CO2 cartridges; a tool bag; a cleaning cloth; booklets; and a scope cap. It exhibits loose components and dents and grime on the case. Dimensions: 36" x 12" x 5" (91.5 cm x 30.5 cm x 12.75 cm) Ownership may be restricted in some countries; see replica firearm notice in Buyer's Guide. Firearm deactivated; see firearm deactivation notice in the Buyer's Guide. Contains electronics; see electronics notice in the Buyer's Guide.

**Estimate: \$400 - 800**



**1393**  
Set of Six Continuity Photo Binders  
**Tales From The Crypt (1989-1996)**

Six continuity photo binders from the horror anthology series Tales from the Crypt. Hosted by the Cryptkeeper, a wisecracking corpse, this horror anthology ran from 1989 to 1995 with a total of 93 episodes. This set consists of six photo albums of 204 pages of behind-the-scenes photographs featuring photos of cast members in costume and makeup, as well as locations, set pieces, and props. The photographs' borders are hand-marked with scene numbers and other continuity information in black ink by production. Also included are continuity photos from The Wonder Years. The set exhibits minor staining on the borders, and yellowing due to age. Dimensions: (each) 11" x 12" x 3" (28 cm x 30 cm x 6.5 cm)

**Estimate: \$3,000 - 6,000**

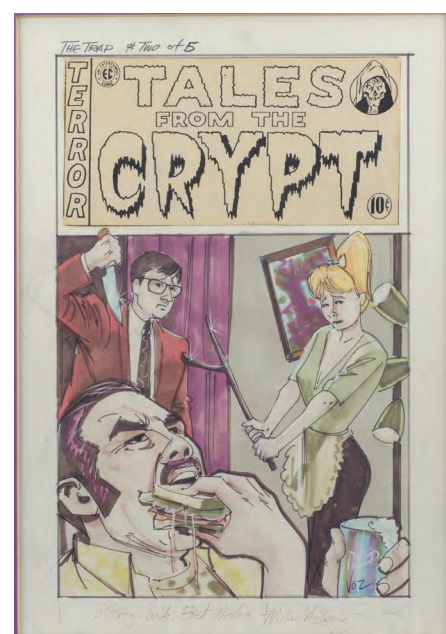
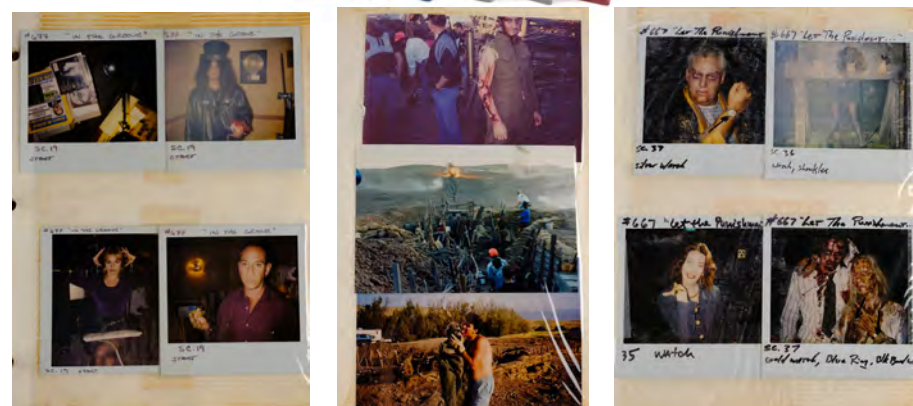

**1394**  
Framed Hand-Illustrated Mike Vosburg "The Trap" Preliminary Cover Artwork  
**Tales From The Crypt (1989-1996)**

Framed preliminary cover artwork hand-illustrated by Mike Vosburg for the horror anthology series Tales from the Crypt. Crypt Keeper (John Kassir) introduced Season 3's "The Trap" with an illustration of Billy and Irene Paloma scheming against Lou Paloma. This comic-style artwork, one of many preliminaries created prior to the selection of a final layout, for the final onscreen cover, is rendered in mixed media on paper, labeled "The Trap #Two of 5," and signed "To Greg with Best Wishes Mike Vosburg" and is mounted behind glass in a custom frame. The handwriting exhibits fading from age. Dimensions: 12" x 15" x 1" (30.5 cm x 38.25 cm x 2.5 cm) Sold without copyright; see notice in the Buyer's Guide.

**Estimate: \$600 - 1,200**



**1395**  
Framed Mike Vosburg "About Face" Cover Artwork Print  
**Tales From The Crypt (1989-1996)**

Framed printed cover artwork by book cover designer Mike Vosburg for the horror anthology series Tales from the Crypt. In the Season 7 episode "About Face," Crypt Keeper (John Kassir) turned to an illustration of a priest, his victim, and a corpse to introduce the episode. This comic-style artwork is printed on specialty paper featuring Vosburg's printed signature. It comes mounted behind glass in a wooden frame. The paper is intentionally burned and stained throughout by production to emulate aging, and it features tape residue along the left edge. Dimensions: 12" x 17" x 1" (30.5 cm x 43.25 cm x 2.5 cm) Sold without copyright; see notice in the Buyer's Guide.

**Estimate: \$800 - 1,600**



**1397**  
Lillith's (Angie Everheart) Metal Pyro Skull  
**Tales From The Crypt Presents: Bordello Of Blood (1996)**

Lillith's (Angie Everheart) metal pyro skull from Gilbert Adler's horror comedy Tales from the Crypt Presents: Bordello of Blood. After her heart was removed, Lillith burst into flames and burned down to her skeletal frame. This lot consists of one metal skull with a metal jaw rod for pyrotechnic scenes. It features an articulated jaw attached to a rod by a strip of metal that allows for the jaw to open and close by moving the rod through the open hole in the back. This skull exhibits discoloration, rust, bent metal, and a loose jaw hinge. Dimensions: 26" x 6" x 7" (66 cm x 15.25 cm x 18 cm)

**Estimate: \$800 - 1,600**



**1396**  
Vincent Prather's (Phil Fondacaro) Framed Treasure Map  
**Tales From The Crypt Presents: Bordello Of Blood (1996)**

Vincent Prather's (Phil Fondacaro) framed treasure map from Gilbert Adler's horror comedy Tales from the Crypt Presents: Bordello of Blood. Prather followed his treasure map to a cave containing Lilith (Angie Everhart), the mother of all vampires. This color-printed map of the Tierra del Fuego archipelago features a trail marked with a red "X." It comes mounted behind glass in a custom wooden frame painted gold-color and black and affixed with a metal hanging wire on the reverse. The map is intentionally distressed by production to appear burned and torn from age and use. Dimensions: 16" x 15" x 1" (40.75 cm x 38.25 cm x 2.5 cm)

**Estimate: \$600 - 1,200**



**1398**  
Tank Girl's (Lori Petty) Screen-Matched Paint-Covered Costume  
**Tank Girl (1995)**

Tank Girl's (Lori Petty) screen-matched paint-covered costume from Rachel Talalay's sci-fi film Tank Girl. Tank Girl wore her paint-covered costume after escaping Water and Power and modified the tank. Paint patterning can be screen-matched throughout. This costume consists of a blue canvas button-up shirt and matching shorts with an elastic waistband, a beige sateen bra, and beige cotton-blend boxers. Included are three hand-marked production tags and one character card in a plastic sleeve. The character card features a still from the film and a character biography. Production purposefully distressed this costume to cover it in paint and make it appear damaged. It exhibits snagged and loose threads and mild discoloration.

**Estimate: \$1,000 - 2,000**



**1399**  
Tank Girl's (Lori Petty) Costume  
**Tank Girl (1995)**

Tank Girl's (Lori Petty) costume components from Rachel Talalay's sci-fi film Tank Girl. Tank Girl wore her costume while on guard duty. This costume consists of a padded red lace bra; gray denim Lip Service zip-up overalls; floral-patterned purple poly-blend shorts with garter clips and black elasticated Calvin Klein pantyhose; a candy necklace; a black elastic armband with red reflector; padded striped tube socks cut off at the toe; 26 loose garter clips; and three United Artists production tags with scene numbers and notes hand-labeled "Lori Petty" and "Tank Girl." The costume is intentionally distressed throughout with slashes, paint splotching, and tears to appear well-worn and fixed by hand. It exhibits discoloration and loose threads. The necklace exhibits mold and is unsafe for consumption.

**Estimate:**  
**\$1,000 - 2,000**



**1400**  
Tank Girl's (Lori Petty) Bra and Skirt  
**Tank Girl (1995)**

Tank Girl's (Lori Petty) bra and skirt from Rachel Talalay's sci-fi film Tank Girl. Tank Girl wore her bra and skirt while eating and dancing with the Rippers after they captured weapon shipments. This lot consists of a black lace bra embroidered with red star appliques on each pad and a matching tulle skirt secured with metal baby pins. Both garments are intentionally distressed by production to appear well-worn and fixed by hand. They exhibit discoloration and snagged threads.

**Estimate:**  
**\$1,000 - 2,000**



**1403**  
Screen-Matched Tank Console  
**Tank Girl (1995)**

A screen-matched tank console from Rachel Talalay's sci-fi film Tank Girl. Tank Girl modified the tank she stole from Water and Power. This piece is screen-matchable at multiple points in the film due to its distinct facets throughout. This lot consists of a tank console portion. It features a metal base and an assortment of knobs and buttons with status lights and decorative decals. It comes with an oil pressure gauge, gold-color plastic trophy toppers, keys, a cylinder case keyway, three more knobs, status lights, and a headless vinyl toy figurine. The back displays cut wire casings. This lot exhibits broken pieces, grime, chipped paint and decals, and notable residue. Dimensions: 12" x 19" x 5" (30.5 cm x 48.25 cm x 12.75 cm)

**Estimate: \$600 - 1,200**



**1404**  
Tank Girl's (Lori Petty) Backpack and Hat  
**Tank Girl (1995)**

Tank Girl's (Lori Petty) backpack and hat from Rachel Talalay's sci-fi film Tank Girl. Tank Girl carried her backpack scavenging and wore her hat as she dressed for the sex club. This lot consists of a canvas and faux leather backpack, hat, and accessories. The backpack's attached bag has a reflective disk, charms, keychains, silver-color foil around one strap, a canteen, spoon, broken toothbrush, map, feather, and gold-color lantern. Included is a ukulele. The hat features dangling cork stoppers. The lot exhibits cracked, peeling leatherette, discoloration, scratches, and production-added distressing to appear aged and dirty. Dimensions: (backpack) 20" x 17" x 12" (51 cm x 43.25 cm x 30.5 cm)

**Estimate: \$800 - 1,600**



**1401**  
Set of Three Continuity Photo Binders  
**Tank Girl (1995)**

Three continuity photo binders from the production of Rachel Talalay's sci-fi film Tank Girl. Tank Girl fought against Water and Power after she joined with mutant kangaroos, The Rippers. These three binders feature white hand-marked labels for "Tank Girl" of 102 pages of behind-the-scenes photographs of cast members including Lori Petty, Naomi Watts, and Malcolm McDowell in costume and makeup, and set pieces and props. Their borders feature scene numbers and continuity information hand-marked in red, blue, and black ink by production. They exhibit some minor staining on the borders, and yellowing due to age. Dimensions: (each) 11" x 12" x 3" (28 cm x 30 cm x 6.5 cm)

**Estimate: \$1,000 - 2,000**



**1402**  
Pair of Missiles  
**Tank Girl (1995)**

A pair of missiles from Rachel Talalay's sci-fi film Tank Girl. Tank Girl (Lori Petty) heavily modified the tank she stole with an assortment of weapons, including a missile launcher. This lot consists of two missiles. Composed of aluminum with cardboard interiors, these missiles feature wood spaces for stability, a wooden warhead, and metal nose cone. They also feature two sets of fins, glossy red paint, and a checkered band behind the warhead. This lot exhibits notable glue marks; chipped and flaked paint; loose and broken components; bent fins; and missing screws. Dimensions: 31" x 10" x 12" (78.75 cm x 25.5 cm x 30.5 cm)

**Estimate: \$500 - 1,000**



**1405**  
Tank Girl's (Lori Petty) "Blow Off" Costume Components with Screen-Matched Apron  
**Tank Girl (1995)**

Tank Girl's (Lori Petty) "Blow Off" costume components with screen-matched apron from Rachel Talalay's sci-fi film Tank Girl. Tank Girl wore her "Blow Off" shirt while being held captive by the Rippers, and sometimes wore the chest apron that is screen-matched to scenes when she is sleeping amongst bowling balls due to the leather's distinctive distressed pattern. This costume consists of one pink cotton shirt with "Blow Off" stenciled onto the front in black; one apron chest-piece made of clear vinyl and black and brown leather with green canvas straps; seven multi-colored, multi-shaped plastic rings; and one yellow plastic chain bracelet with a red urchin ball pendant. The shirt features a half placket with snap closures and serged hems. This costume exhibits discoloration, loose threads, and broken urchin spines.

**Estimate: \$800 - 1,600**



**1406**  
Tank Girl's Stunt Costume Components  
**Tank Girl (1995)**

Tank Girl's stunt costume components from Rachel Talalay's sci-fi film Tank Girl. Tank Girl wore her costume components while she modified the tank and infiltrated the sex club. This lot consists of two seed beaded headbands with feathers, a pair of black cable socks, and a pair of brown leatherette gloves. The gloves feature a hand-marked label for "STUNT" in black ink inside, and a hand-marked production tag listing the scene "A11b, 118, 119, 121, 123," and change as "9C." Also included is a promotional trading card. This lot exhibits notable discoloration, flaked vinyl, fold lines, and fragility of the feathers.

**Estimate: \$800 - 1,600**



**1407**  
Tank Girl's (Lori Petty)  
Straitjacket and Boots  
**Tank Girl (1995)**

Tank Girl's (Lori Petty) straitjacket and boots from Rachel Talalay's sci-fi film Tank Girl. Kesslee (Malcolm McDowell) put Tank Girl in a straitjacket as he tortured her to break her spirit. This costume consists of a beige canvas straitjacket with metal hardware and a pair of black leather boots with buckles. The straitjacket features a center panel with a built-in bra and 12 belts on the front with double D-ring buckles. The boots feature a rubber sole with platform bottom. Production intentionally distressed this costume to appear used. It exhibits snagged and loose threads, discoloration, and cracking on the boots.

**Estimate: \$800 - 1,600**



**1408**  
Tank Girl's (Lori Petty)  
Production-Made Blue  
Safety Helmet  
**Tank Girl (1995)**

Tank Girl's (Lori Petty) production-made blue safety helmet from Rachel Talalay's sci-fi film Tank Girl. Tank Girl wore her helmet during the final raid on Water and Power. This production-made helmet consists of one blue plastic safety hardhat that features a packaged green condom on the front with "Safety First!" hand-marked above it in black marker. The inside features tan plastic and nylon straps. This lot exhibits scratches and faded writing.

**Estimate: \$500 - 1,000**



**1410**  
Brian Moreland's (Timothy Hutton) Siege Costume  
Components  
**Taps (1981)**

Brian Moreland's (Timothy Hutton) siege costume components from Harold Becker's drama film Taps. Moreland wore his uniform while commanding the siege of Bunker Hill. This lot consists of a pair of camouflage trousers marked "MORELAND"; a black nylon belt with a black metal buckle; a pair of green long socks; and an 8" x 10" black-and-white movie still of Hutton in his costume. This lot exhibits minor pilling on the socks and minor loose threads on the belt.

**Estimate: \$1,500 - 3,000**



**1411**  
Brian Moreland's (Timothy Hutton)  
Bunker Hill Costume  
**Taps (1981)**

Brian Moreland's (Timothy Hutton) Bunker Hill costume from Harold Becker's drama film Taps. Moreland wore his Bunker Hill uniform during his commencement. Designed by Eddie Marks, this lot consists of a black polyester blend long-sleeve button down (size 15/34) with gold-color and silver-color pins marked "Tim Hutton"; a black nylon belt with a gold-color brass buckle; light blue wool trousers (size 32 Regular) with black nylon stripes marked "Valley Forge Military Academy" and "TH #2"; a matching hat with yellow trim and gold-color metal buttons; and a pair of black long socks. This lot exhibits minor stains to the hat.

**Estimate: \$1,500 - 3,000**

**1412**  
General Harlan Bache's (George C.  
Scott) Military Dress Uniform  
**Taps (1981)**

General Harlan Bache's (George C. Scott) military dress uniform from Harold Becker's drama film Taps. General Bache wore his military dress uniform during a baccalaureate service in a church. Created by costume supervisor Eddie Marks, this uniform consists of a black wool tie; black trousers with a set of goldenrod-color stripes down the sides; a matching jacket with gold-color metal U.S. seal buttons and goldenrod-color straps around the cuffs. Included with this lot is an 8" x 10" black-and-white movie still of Scott in his costume. This lot exhibits minor stains on the photo.

**Estimate: \$1,500 - 3,000**



**1413**  
262 Unpublished Behind-the-  
Scenes Production Reference Slides  
**The Terminator (1984)**

Unpublished behind-the-scenes production reference slides from James Cameron's sci-fi film The Terminator. Kyle Reese (Michael Biehn) had a nightmare of the future war between Skynet and the human resistance. The binder consists of 262 color slides featuring the Terminators and various future war scenes stored in 18 plastic slide pages. Each slide features a sticker with hand-written "JV" initials followed by a unique 2- to 3-digit identification number. Select slides feature various annotations in the margins, including attribution to Joe Viskocil as photographer on the reverse. The lot exhibits tape residue, grime, and edge wear. Dimensions: 10.5" x 11.5" x 1.5" (26.75 cm x 29.25 cm x 3.75 cm)

**Estimate: \$1,200 - 2,400**



**1409**  
Tank Girl's (Lori Petty) Accessories  
**Tank Girl (1995)**

Tank Girl's (Lori Petty) accessories from Rachel Talalay's sci-fi film Tank Girl. Tank Girl wore dog tags, a necklace and sunglasses during the film. This lot consists of plastic chrome sunglasses; metal dog tags debossed with "Buck, Rebecca 2437265 A POS AUSTRALIAN"; and a necklace with assorted charms. The dog tags and necklace come with original production tags hand-marked for "Lori Petty" in "Tank Girl," "Baby doll arm necklace with silver heart," and "Tank Girl dog tags." Included is a brown leather belt and four Tank Girl postcards. This lot exhibits discoloration, chipped paint, and scratches. Dimensions: 12" x 2" x 5.5" (30.5 cm x 5 cm x 14 cm)

**Estimate: \$600 - 1,200**



**1414**  
License Plate  
**The Terminator (1984)**

A license plate from James Cameron's sci-fi film *The Terminator*. After telling the police officer at the front desk "I'll be back," the T-800 Terminator crashed a car through the front of the police station.

This lot consists of one metal license plate featuring a black background with the embossed "WWX 239" and "California" in yellow. This license plate has four screw holes for a frame, and one center hole at the top. The number "63" is imprinted on the upper right corner. It exhibits some denting to the metal, chipped paint, and notable rust. Dimensions: 12" x 6" (30.5 cm x 15.25 cm)

**Estimate: \$1,200 - 2,400**

**1415**  
The Terminator's (Arnold Schwarzenegger) Faux Leather Trousers  
**Terminator 2: Judgment Day (1991)**

The Terminator's (Arnold Schwarzenegger) faux leather trousers from James Cameron's sci-fi action sequel *Terminator 2: Judgment Day*. The T-800 wore his faux leather trousers, which he stole from a disgruntled biker, throughout the film. The black faux leather trousers are unsized, feature ankle zippers, and intentional distressing by production. They exhibit substantial flaking of the faux leather from age.

**Estimate: \$2,000 - 4,000**

**1416**  
Binder of Production Storyboards  
**Terminator 2: Judgment Day (1991)**

A binder of production storyboards from James Cameron's sci-fi sequel *Terminator 2: Judgment Day*. This binder outlined and coordinated the special effects needed for the film. From the collection of Joe Viskocil, this black plastic binder features approximately 400 pages of storyboard copies, copied and watermarked script segments, schedules, line lists, and various ephemera, all tab-divided by scene and topic. The "Meeting" and "Contacts" tabs are void of content. This lot exhibits bent corners, creasing, and edge wear. Dimensions: 11.5" x 11.5" x 3.5" (29.25 cm x 29.25 cm x 9 cm)

**Estimate: \$1,000 - 2,000**



**1417**  
T-600 M203 Grenade Launcher and Ammo Backpack  
**Terminator Salvation (2009)**

A T-600 M203 grenade launcher and ammo backpack from McG's sci-fi sequel *Terminator Salvation*. T-600 Terminators carried M203 grenade launchers as they hunted Marcus Wright (Sam Worthington) and Kyle Reese (Anton Yelchin). This lot consists of a black rubber gun attached to a metal ammo backpack via a black and blue plastic ribbed tube. The backpack also features padded nylon straps. Production intentionally distressed the metal backpack to appear rusted with age. This lot exhibits some discoloration, cracks, and pitting. Dimensions: 24" x 15" x 7" (60 cm x 38 cm x 18 cm)

**Estimate: \$2,500 - 5,000**



**1419**  
John Connor's (Christian Bale) Screen-Matched Makeshift Electronic Key with Light-Up Moto-Terminator Optic Sensor  
**Terminator Salvation (2009)**

John Connor's (Christian Bale) screen-matched makeshift electronic key with a light-up Moto-Terminator optic sensor from McG's sci-fi action sequel *Terminator Salvation*. This lot screen-matches when Connor retrofitted a Moto-Terminator's optical sensor with electronic components to gain access to Skynet headquarters. This lot features a metal and plastic light shaped like a Terminator eyeball, mounted to an electronic circuit board. The battery-operated eye is activated by a metal switch on the circuit board's underside. The item's blue light was ultimately changed to red in post-production. It exhibits some discoloration, component fragility, cut wires, and flaked paint. Dimensions: 6" x 3.5" x 3.75" (15.25 cm x 9 cm x 9.5 cm) Contains electronics; see electronics notice in the Buyer's Guide.

**Estimate: \$1,500 - 3,000**



**1418**  
John Connor's (Christian Bale) Screen-Matched Tape Recorder with Sarah Connor (Linda Hamilton) Recordings  
**Terminator Salvation (2009)**

John Connor's (Christian Bale) screen-matched tape recorder with Sarah Connor (Linda Hamilton) recordings from McG's sci-fi action sequel *Terminator Salvation*. John listened to tapes his mother Sarah left for him about how to defeat Skynet. This functional, black and gray plastic Radio Shack Vox CTR-121 tape recorder with serial number "L229580" plays back a recording of Sarah Connor speaking to John when installed with four "C" batteries. It exhibits intentional, screen-matchable staining distressing by production to appear well-used, with scratching and wear to the metallic finish on the buttons. Dimensions: 9.5" x 6" x 2" (24.25 cm x 15.25 cm x 5 cm) Contains electronics; see electronics notice in the Buyer's Guide.

**Estimate: \$2,000 - 4,000**



**1420**  
T-600 Ammunition Backpack  
**Terminator Salvation (2009)**

A T-600 ammunition backpack from McG's sci-fi sequel *Terminator Salvation*. The T-600 Terminators carried M203 grenade launchers as they hunted Marcus Wright (Sam Worthington) and Kyle Reese (Anton Yelchin). This lot consists of a metal ammo backpack. The backpack features padded nylon straps with plastic buckles. Production intentionally distressed the metal backpack to appear rusted and grime-covered with age. This lot exhibits some discoloration and warping of the metal. Dimensions: 24" x 15" x 7" (60 cm x 38 cm x 18 cm)

**Estimate: \$800 - 1,600**



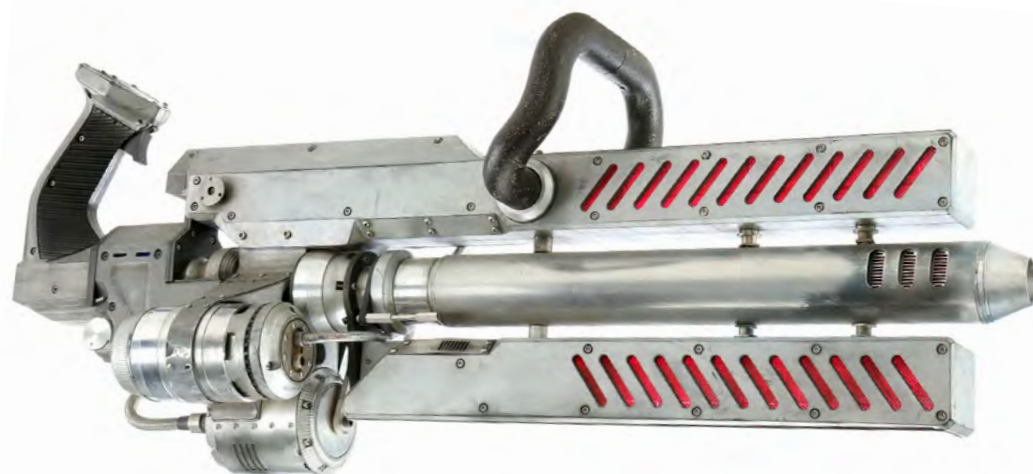

**1421**  
**Light-Up Aluminum T-600 Plasma Minigun**  
**Terminator Genisys (2015)**

A light-up aluminum T-600 plasma minigun from Alan Taylor's sci-fi action sequel Terminator Genisys. John Connor (Jason Clarke) used his minigun to destroy a T-600 Infiltrator Terminator before it killed the adolescent Kyle Reese (Bryant Prince). This aluminum and stainless steel plasma minigun features an illuminating barrel and a black resin handle. The sides feature several wires and switches that operate internal red and blue LED lights, while the trigger operates a "blast" light sequence. It exhibits signs of wear from age and production use, including scuffing to the finish. Dimensions: 30" x 8" x 13" (76.25 cm x 20.5 cm x 33.25 cm) Contains electronics; see electronics notice in the Buyer's Guide.

**Estimate: \$4,000 - 8,000**



**1422**  
**T-800's (Arnold Schwarzenegger) CPU Chip with Sarah Connor (Emilia Clarke) Pliers and Three Liquid Magnet Shotgun Rounds**  
**Terminator Genisys (2015)**

T-800's (Arnold Schwarzenegger) CPU chip with Sarah Connor (Emilia Clarke) pliers and three liquid magnet shotgun rounds from Alan Taylor's sci-fi action sequel Terminator Genisys. Sarah used various tools throughout the film. The steel, long-needle nose pliers feature a textured rubber grip. The multicolor-painted metal chip features black painted inlays. Three brass and plastic shells feature partially-silver painted interiors with black printed information. The pliers exhibit minor discoloration, scratching, and chipping; the chip and shells exhibit paint chipping and edgewear. Dimensions: (pliers) 12" x 3" x 0.5 (30.5 cm x 13 cm x 1.25 cm); (shells) 3" x 1" x 1" (8 cm x 3 cm x 3 cm)

**Estimate: \$800 - 1,600**



**1423**  
**T-800's Pre Battle Costume** Δ  
**Terminator: Dark Fate (2019)**

T-800's pre battle costume from Tim Miller's action-sci-fi film Terminator: Dark Fate. T-800 wore its costume when it was preparing to fight the Rev-9 to protect Dani. This lot consists of a gray cotton shirt (size XL) with a production label marked "Stunt"; a black cotton shirt (size 3XL) labeled "T-800 Bigger For Harness"; a pair of blue poly-cotton jeans (size 38 x 34) labeled "T-800 Double" and "2. Arnold"; a brown painted jacket marked "T-800"; and a brown leather belt. This lot exhibits a stickiness on the latex skin.

**Estimate: \$2,000 - 4,000**



**1424**  
**Sarah Connor's Arrival at Felipe's Costume** Δ  
**Terminator: Dark Fate (2019)**

Sarah Connor's arrival at Felipe's costume from Tim Miller's action-sci-fi film Terminator: Dark Fate. Sarah wore her costume when she arrived at Felipe's house with Grace and Dani. This lot consists of a black cotton shirt marked "Sarah Hero" on a sewn label; a beige cotton-twill jacket marked "Sarah Stunt" on a sewn label; and a pair of brown cotton pants marked "Sarah Stunt" on a sewn label. This lot exhibits discoloration from production use.

**Estimate: \$1,200 - 2,400**



**1425**  
**Future War Soldier Costume with Light-Up Helmet** Δ  
**Terminator: Dark Fate (2019)**

A future war soldier costume with light-up helmet from Tim Miller's sci-fi action film Terminator: Dark Fate. The soldiers wore uniforms during Grace's memory sequences. This costume consists of a gray light-up helmet; a black cotton hat; black poly-blend neoprene dicky; black shoulder pads; a camo jacket; black elbow pads; black wrist guards; black gloves; camo trousers; black knee pads; and black boot covers. The body armor is made of fiberglass, plastic, and nylon, and features fastening strips to attach it. Production intentionally distressed the lot to appear damaged and dirty. This lot exhibits notable paint marks and snagged threads. Contains electronics; see electronics notice in the Buyer's Guide.

**Estimate: \$800 - 1,600**



**1426**  
**Leatherface's (Andrew Bryniarski) Distressed Shirt**  
**The Texas Chainsaw Massacre: The Beginning (2006)**

Leatherface's (Andrew Bryniarski) distressed shirt from Jonathan Liebesman's horror prequel The Texas Chainsaw Massacre: The Beginning. The young Leatherface wore his shirt while he worked at a slaughterhouse as Thomas Hewitt. This blue and brown striped cotton long-sleeve shirt (size 2XL) features matching faux ivory button closures on the front and sleeves. Also included is a wardrobe tag labeled for "Leatherface," scene number "2-4," and set "Early No Blood." The shirt exhibits intentional, extensive distressing by production to appear well-worn with sweat and blood stains throughout and a torn hem at the back.

**Estimate: \$1,000 - 2,000**



**1427**  
Louise's (Susan Sarandon) Screen-Matched Straw Cowboy Hat  
**Thelma & Louise (1991)**

Louise's (Susan Sarandon) screen-matched straw cowboy hat from Ridley Scott's adventure-drama film *Thelma and Louise*. The distressed patterns screen-match the hat Louise wore as she and Thelma (Geena Davis) made their grand escape from the police at the Grand Canyon. This beige straw Resistol "Self-Conforming" Western hat features two twisted brown leather bands, a wire-enforced brim, and a tied brown leather chin cord. This lot exhibits intentional distressing throughout.

**Estimate: \$3,000 - 6,000**

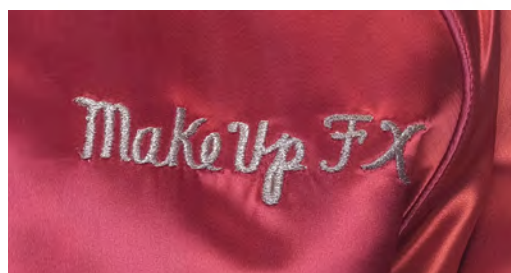

**1428**  
Makeup FX Production Crew Jacket  
**The Thing (1982)**

A makeup FX production crew jacket from John Carpenter's science fiction horror *The Thing*. The production's makeup crew numbered 35 special makeup effects artists who worked 14 months on the film. This burgundy satin letterman-style jacket (size Medium) features open-slit pockets, a nylon front-zip, beige satin lining, and navy blue elastic cuffs, hem, and neck. It features pewter and silver-color sparkle embroidery of "Make Up FX" on front right chest, with a large logo of the movie's title at the back. It exhibits orange discoloration around the shoulders, arms, and at the back and sides due to prolonged sun exposure.

**Estimate: \$1,200 - 2,400**



**1429**  
Set of Production Ephemera  
**The Thing (1982)**

Production ephemera from John Carpenter's science fiction horror *The Thing*. This set comes from writer/producer and documentarian Craig Miller, the film's uncredited marketing consultant. The lot consists of one black binder with 200 black-and-white storyboard copies; one black folder-bound, 121-page second draft script; one blue folder-bound, 131-page final draft script; two copies of Joseph W. Campbell Jr.'s "Who Goes There?" paper-covered, 31-page novelette; and one untested trailer cassette tape in a plastic brown case. This lot exhibits tears, edge wear, staining, and sticky residue. Dimensions: (largest) 8.5" x 11" x 0.5" (21.5 cm x 28 cm x 1.25 cm)

**Estimate: \$1,000 - 2,000**



**1430**  
Set of Tick Puppets  
**Ticks (1993)**

Tick puppets from Tony Randel's horror film *Ticks*, also known as *Infested*. Jarvis Tanner (Clint Howard) inadvertently created mutant ticks with chemical runoff which allowed the ticks to grow in size and infest the forest. This lot consists of three puppets and one egg sac. The foam puppets feature one tick with spring legs, one rod-controlled tick, and one static tick with a metal two-prong hook underneath. The egg sac is made of soft foam and covered in latex. This lot exhibits foam fragility and unattached components. Dimensions: 13" x 10.25" x 6" (33 cm x 26 cm x 15.25 cm)

**Estimate: \$600 - 1,200**



**1432**  
Stuart Ziff Collection: Kuato's (Marshall Bell) Vacuum-Formed Face  
**Total Recall (1990)**

Kuato's (Marshall Bell) vacuum-formed face from Paul Verhoeven's sci-fi action film *Total Recall*. Douglas Quaid (Arnold Schwarzenegger) and Melina (Rachel Ticotin) were introduced to Kuato, the mutant leader of the Martian resistance. This lot comes from the collection of Bottin Effects Crew member Stuart Ziff. It consists of a white plastic vacuum-formed pull with an infant-esque face design for the conjoined mutant carried by George and an additional foam latex segment. The latex exhibits notable residue, fragility, and cracking along the edges. Dimensions: 7" x 5" x 4" (18 cm x 12.75 cm x 10.25 cm)

**Estimate: \$500 - 1,000**



**1431**  
Life Vest  
**Titanic (1997)**

A life vest from James Cameron's romantic disaster film *Titanic*. Passengers made use of their life vests throughout the film's iconic sinking sequences as they struggled to evacuate the doomed vessel. This vest is constructed from cream-color canvas with foam padding stitched into the front and back and matching wrap-around nylon straps on each side. The vest is speckled with grime and exhibits stains and sticky residue on the straps from production wear.

**Estimate: \$2,000 - 4,000**



**1433**  
Cade Yaeger's (Mark Wahlberg) Guard-Dawg  
**Transformers: Age Of Extinction (2014)**

Cade Yaeger's (Mark Wahlberg) guard-dawg from Michael Bay's action sci-fi *Transformers: Age of Extinction*. Yaeger's home security invention was mostly ineffectual and loitered around his residence. This mixed-media, dog-shaped mechanism is atop an exposed remote-controlled vehicle chassis featuring silver-color metal grating, black rubber tires, and electronic motors. It features plastic silver-color painted plating, black rubber trim, metal rivets, exposed wires, plastic tubing, and electronic boards. The head features a gray metal jaw, eyes made from flashlight lenses, and a black leather and metal studded dog collar. It is non-functional and exhibits minor scuffing, scratches, dirtied treads, and loose components. Dimensions: 30" x 14" x 21" (76.25 cm x 35.5 cm x 53.5 cm) Contains electronics; see electronics notice in the Buyer's Guide.

**Estimate: \$1,500 - 3,000**



**1434**  
Menelaus' (Brendan Gleeson)  
Costume  
**Troy (2004)**

Menelaus' (Brendan Gleeson) costume from Wolfgang Petersen's historical action epic Troy. Spartan King Menelaus wore his armor while Hector (Eric Bana) attempted to reclaim his wife, Helen (Diane Kruger) from Troy. This lot consists of battle-distressed brown dense rubber body armor with leather accents and straps; a pair of rubber gauntlets with metal details and leather laces; a green cotton skirt with leather and metal details marked "MR. GLEESON"; and rubber shin guards with metal detail and leather laces. This lot exhibits signs of wear from age and use, including a missing leather strap on one shin guard.

**Estimate: \$1,500 - 3,000**



**1435**  
Aziz's (Art Malik) Destroyed  
Helicopter Model Miniature Tail  
Section  
**True Lies (1994)**

Aziz's (Art Malik) destroyed helicopter model miniature tail section from James Cameron's action-comedy True Lies. Harry Tasker (Arnold Schwarzenegger) destroyed a radical terrorist group's helicopter using a sidewinder missile Aziz had been entwined to. The tail section is fiberglass-backed resin and painted dark gray to appear metallic, and features goldenrod-color painted tail numbers and decorative striping flanked by white painted border stripes. The broken-off resin tail fin and horizontal stabilizer fins are similarly finished. The stabilizer fins are removable from brass metal piping. The lot exhibits paint chipping, cracking, jagged edges, and glue residue. Dimensions: 43" x 12" x 7" (109.25 cm x 30.5 cm x 17.75 cm)

**Estimate: \$1,500 - 3,000**



**1436**  
Lauren Garland's (Natascha McElhone) Dress and  
Earrings  
**The Truman Show (1998)**

Lauren Garland's (Natascha McElhone) dress and earrings from Peter Weir's satirical psychological drama The Truman Show. Garland, a Truman Show extra playing Sylvia, fell for unwitting reality-star Truman Burbank (Jim Carrey) and advocated for his freedom after her removal by executive producer Christof (Ed Harris). While unseen in the film's final cut, the ivory cotton silk dress features a button closure and embroidered leaf patterning. Included are a pair of tab-style green-tinted resin translucent earrings on silver-color metal wire ear hooks. The lot includes a costume tag hand-marked in black with actress' name, character, costume change number, scene number, and the film attribution. The dress exhibits minor discolorations and staining, while the earrings exhibit scratches and nicks.

**Estimate: \$1,500 - 3,000**



**1437**  
Bella Swan's Cullen House Costume  
Components  
**Twilight (2008)**

Bella Swan's Cullen house costume components from Lionsgate's blockbuster hit Twilight. Bella wore her cardigan and shirt when she first met the Cullen family at their home and climbed trees with Edward Cullen. These costume components consist of a green cotton and polyester blend long-sleeve henley (size M) hand-marked "TW" on the interior tag and a cream-color woven cotton blend cardigan with braided patterns, faux tortoiseshell buttons, and a high collar hand-marked "TW." The shirt's seam is splitting on the reverse and the sweater exhibits some pilling from production wear.

**Estimate: \$3,000 - 6,000**



**1438**  
Edward Cullen's Multnomah Falls  
Costume Components  
**Twilight (2008)**

Edward Cullen's Multnomah Falls costume components from Lionsgate's blockbuster hit Twilight. Edward wore various iterations of his costume when he spoke with Bella Swan by the lake and when he visited her in the hospital. These components consist of a blue windbreaker (size L) hand-marked "TW" with an assortment of pockets and a snap- and button-lined zipper front; a gray cotton thermal (size S); and two black trainers with blue accents labeled "Stunt." Also included is a wardrobe tag with character and scene notes. The shoes were intentionally distressed by production to appear water-damaged and the thermal exhibits minor fraying.

**Estimate: \$1,500 - 3,000**



**1439**  
Edward Cullen's Tree Climbing  
Costume  
**Twilight (2008)**

Edward Cullen's tree climbing costume from Lionsgate's blockbuster hit Twilight. Edward wore his costume when he climbed a tree with Bella Swan on his back at his family home. The lot consists of a blue and white pinstripe patterned, long-sleeve, button-down shirt with a single left breast pocket; and a pair of dark blue denim jeans. This lot exhibits tears along the pocket and waist lining on the jeans and a stitch along the upper back of the shirt from the stunt and harness work used in the scene.

**Estimate: \$3,000 - 6,000**



**1440**  
**Bella Cullen's Stunt Newborn Vampire Dress**  
**The Twilight Saga: Breaking Dawn-Part 1 (2011)**

Bella Cullen's stunt newborn vampire dress from The Twilight Saga: Breaking Dawn - Part 2. Bella wore her blue dress when she awoke as a vampire and went on her first hunt with Edward. The custom-made, sleeveless blue cotton-blend dress features a scoop neck, pintucks at the waist, a slit up the thigh, a zipper on the back, and tag inside hand-marked "Bella Harness." The dress exhibits minimal wear from use, including a few small holes.

**Estimate: \$3,000 - 6,000**



**1441**  
**Bella and Edward Flower Arrangements**  
**The Twilight Saga: Breaking Dawn-Part 1 (2011)**

Bella and Edward flower arrangements from Bill Condon's supernatural romance sequel The Twilight Saga: Breaking Dawn Part 1. Flowers and moss arrangements were primary decorations at Bella and Edward's forest wedding. This lot consists of assorted flowers and one photograph. Composed of polyester with plastic and wire stems, these flowers feature predominately white petals with one bunch of purple flowers. Printed on U.S. letter size 8.5" x 11" (22 cm x 28 cm) paper, the photograph features Bella and Edward at their wedding. This lot exhibits loose components, exposed wires, and paper creasing. Dimensions: 43" x 17" x 4" (109.25 cm x 43.25 cm x 10.25 cm)

**Estimate: \$400 - 800**



**1444**  
**Cast Autographed "A" Clapperboard and Annotated Script**  
**Unbreakable (2000)**

A cast autographed "A" clapperboard and annotated script from the production of M. Night Shyamalan's thriller Unbreakable. This lot consists of a clapperboard and a script. The 1999, 128-page, brad-bound script features a salmon color cover and annotations. The clapperboard features an acrylic white slate with M. Night Shyamalan, cinematographer Eduardo Serra, and various fields engraved in red and the title and logo engraved in black. The front features autographs including Bruce Willis, Samuel L. Jackson, Robin Wright, and M. Night Shyamalan in black marker. It exhibits discoloration and script edgewear. Dimensions: 12" x 12" x 3" (30.5 cm x 30.5 cm x 7.75 cm)

**Estimate: \$2,000 - 4,000**



**1442**  
**Esme Cullen's Battle Costume**  
**The Twilight Saga: Breaking Dawn-Part 2 (2012)**

Esme Cullen's battle costume from Lionsgate's blockbuster hit The Twilight Saga: Breaking Dawn - Part 2. Esme wore her costume during the Cullen family's climactic battle with the Volturi. This costume consists of a brown polyester-blend zip-up jacket (size 42) marked "st"; a blue cotton ruffled blouse (size S); a gold-color necklace with two attached metal charms and two spare charms; gray cotton-blend jeggings (size XS); and brown leather high-heel slip-on boots (size 9M) marked "Esme back up st." The shirt exhibits tearing on the reverse, and torn paper lettering is stuck to the bottom of the boots from production.

**Estimate: \$2,000 - 4,000**



**1443**  
**Gold Winged Backplate**  
**Unknown Production**

Gold winged backplate from an unknown production. These detailed, hinged fiberglass wings are screwed into a foam-padded backplate, painted gold, and coated with glossy gold-color foil. They exhibit chipping materials on the ends, as well as flaking foil and paint throughout. Dimensions: 54" x 20" x 18" (136.25 cm x 51 cm x 45.75 cm)

**Estimate: \$600 - 1,200**



**1445**  
**Ziodex Industries Blood Bag**  
**Underworld (2003)**

A Ziodex Industries blood bag from Len Wiseman's action horror film Underworld. Selene (Kate Beckinsale) prepared for Viktor's (Bill Nighy) awakening by getting him synthetic blood made by Ziodex, a company owned by Vampires of the Old World Coven that was solely responsible for the Vampires' blood supply. This lot consists of a plastic blood bag filled with dark red-color gel, featuring a blue plastic cap and a "Ziodex Industries" label on the front. This lot exhibits some discoloration and sticky residue. Dimensions: 6" x 10.5" x 0.75" (15.25 cm x 26.75 cm x 2 cm) The food/liquid/makeup in this lot was created as a prop and is not safe for consumption.

**Estimate: \$600 - 1,200**



**1446**  
**Lucian's (Michael Sheen) Water-Treated Leather Trench Coat**  
**Underworld: Rise Of The Lycans (2009)**

Lucian's (Michael Sheen) water-treated leather trench coat from Len Wiseman's action horror film Underworld. Lucian wore his leather trench coat during the final confrontation with Viktor (Bill Nighy). This lot consists of a water-treated leather trench coat. Made of solid black leather, this coat features braided stitch detailing along the arms, front, back, and sides. It utilizes two leather strap belts for closure on the front. Larger strips of leather are weaved throughout the shoulders for embellishment. The interior of the collar features a hand-marked tag with "Medium 201" written on it in ink. This lot exhibits stiffness, discoloration, and mildew residue.

**Estimate: \$2,500 - 5,000**



**1447**  
Viktor's (Bill Nighy) Costume  
**Underworld: Rise Of The Lycans (2009)**

Viktor's (Bill Nighy) costume from Patrick Tatopoulos' action-fantasy *Underworld: Rise of the Lycans*. Viktor wore his costume as he debated killing newborn Lucian. This lot consists of a black leather belt with a brass-color metal buckle and designs; a black polyester waistband; a black wool overcoat with a gold-color trim and black sequins; a black polyester-blend vest with a gold-color trim neck and brass-color metal clasp buttons labeled "Flashback Viktor"; a gold velvet skirt labeled "Viktor Hero"; and one production tag. This lot exhibits minor loose threads.

**Estimate: \$5,000 - 10,000**



**1448**  
IPU Ultraviolet Light-up Submachine Gun  
**Underworld: Awakening (2012)**

An IPU ultraviolet light-up submachine gun from Mans Marland and Bjorn Stein's action horror sequel *Underworld: Awakening*. The soldiers of the Infected Persons Unit (IPU) carried and used their weapons to purge the world of immortals. This lot consists of one static light-up gun painted black. Made of foam rubber, this gun takes its design from a modified FN P90 submachine gun. It features a custom shell with two attached non-functional lights, one non-functional metal scope, and a magazine of ultraviolet light rounds. Production intentionally distressed this gun to appear used. This lot exhibits loose components, notable residue marks, fragility, and cracks in the foam. Dimensions: 27" x 9" x 5.5" (70 cm x 23 cm x 14 cm) Contains electronics; see electronics notice in the Buyer's Guide.

**Estimate: \$3,000 - 6,000**



**1449**  
Set of 45 Hand-Drawn Doug Brode Cut "Creature from the Black Lagoon" Storyboard Pages with Concept Sketch  
**Van Helsing (2004)**

45 hand-drawn Doug Brode cut "Creature from the Black Lagoon" storyboard pages with a concept sketch for Stephen Sommers' action fantasy *Van Helsing*. Cut from the movie, these storyboards revealed during the underground cave scene, instead of falling to his death, Igor was attacked by the Gill-Man. These storyboard pages are rendered, numbered, and annotated in graphite on U.S. letter-size paper. A mixed media concept illustration featuring Gill-man and Frankenstein's Monster is signed by Brode. Several panels were adhered to the letter-size paper. The set exhibits creasing, smudging, torn edges, and lifted adhesive. Dimensions: 16.5" x 11.5" (42 cm x 29.5 cm) Sold without copyright. See notice in the Buyers Guide.

**Estimate: \$1,500 - 3,000**



**1450**  
Van Helsing's (Hugh Jackman) Stunt Pistol  
**Van Helsing (2004)**

Van Helsing's (Hugh Jackman) stunt pistol from Stephen Sommers' fantasy-adventure film *Van Helsing*. Van Helsing carried his pistols throughout the film, using them to fight Mr. Hyde (Robbie Coltrane), the Wolfman (Will Kemp), and Frankenstein's Monster (Shuler Hensley). Modeled after a revolver, the custom-made, dense rubber gun is painted to resemble tarnished metal and brass. Etched Chinese symbols run down both sides of the barrel and its black-painted grip is decorated with a cast-in red and-brass-color Holy Cross. The weapon has been intentionally distressed and exhibits minor wear from production use, including minor scratching and scuffs to the paint finish. Dimensions: 12" x 7" x 2" (30.5 cm x 18 cm x 5.25 cm)

**Estimate: \$1,500 - 3,000**



**1452**  
Articulated Arm  
**The Walking Dead (2010-2022)**

An articulated arm from AMC's horror series *The Walking Dead*. Zombified dead known as "walkers" feasted on the flesh of the living, who fought back to defend themselves. Many on both sides lost limbs throughout the conflict. This arm consists of a metal armature under highly-detailed pale silicone flesh with production-applied dirt and distressing. The armature has points of articulation in the fingers for flexibility, and the wrist is loose, allowing the hand to realistically flop up and down. The silicone exhibits splitting in places, leaving the metal underneath visible in areas such as the knuckles and finger tips. Dimensions: 19" x 6" x 4" (48.5 cm x 15.25 cm x 10.25 cm)

**Estimate: \$1,200 - 2,400**



**1451**  
Negan Smith's (Jeffrey Dean Morgan) Mailbox  
**The Walking Dead (2010-2022)**

Negan Smith's (Jeffrey Dean Morgan) mailbox from AMC's horror series *The Walking Dead*. In the Season 10 episode "Here's Negan," Negan burned his house and its contents to the ground after his wife, Lucille (Hilarie Burton), turned herself into a Walker. This metal mailbox is painted white with blue butterfly emblems and "Smith" on each side. It comes affixed on the left side with a red mail flag. The mailbox exhibits intentional distressing by production to appear aged and abandoned with rust, grime, and scuffing applied throughout. Dimensions: 20.5" x 9.5" x 6.5" (52.25 cm x 24.25 cm x 16.5 cm)

**Estimate: \$1,000 - 2,000**



**1453**  
Alexandria Safe-Zone Wall Panel  
**The Walking Dead (2010-2022)**

An Alexandria safe-zone wall panel from AMC's horror series *The Walking Dead*. Survivors of the zombie apocalypse lived behind corrugated steel walls in the Alexandria safe-zone from Seasons 5 to 11. This steel panel is intentionally distressed by production with scratches and rust to appear well-exposed to walker attacks and weather over several years. It exhibits jagged edges from being cut from a larger steel sheet and should be handled with caution. Dimensions: 6" x 6" x 0.25" (15.25 cm x 15.25 cm x 0.75 cm)

**Estimate: \$400 - 800**



**1454**  
Rick Grimes' (Andrew Lincoln) Gutter  
**The Walking Dead (2010-2022)**

Rick Grimes' (Andrew Lincoln) gutter from AMC's post-apocalyptic television series The Walking Dead. In the Season 4 episode "Claimed," Rick clambered down the gutter of an abandoned home after choking a scavenger (Scott Dale) in its bathroom. This aluminum K-style gutter originated with Mayor William "Dub" Pearson, whose Senoia, Georgia home was used for the sequence. It is painted white on the outside and intentionally distressed by production to appear scuffed by Grimes. The interior exhibits dust from exposure. Dimensions: 48" x 6" x 5" (122 cm x 15.25 cm x 12.75 cm)

**Estimate: \$400 - 800**



**1455**  
Set of 10 Bloodied United States Transportation Maps  
**The Walking Dead (2010-2022)**

10 bloodied United States transportation maps from AMC's post-apocalyptic television series The Walking Dead. In the Season 11 episode "Warlords," Commonwealth guards lost maps that led Negan Smith (Jeffrey Dean Morgan), Maggie Rhee (Lauren Cohan), and their crew to Riverbend. This set consists of 10 matching color-printed and pre-folded United States transportation maps. Two maps are blood-stained by production with one hand-labeled "Riverbend" on the interior with an arrow pointing to a coordinate point. The set exhibits edge wear, fold lines, and some grime from production use and handling. Dimensions: (each) 20" x 24" (51 cm x 61 cm)

**Estimate: \$400 - 800**



**1457**  
Set of Human Costume Components  
**The Walking Dead (2010-2022)**

Human costume components from AMC's post-apocalyptic television series The Walking Dead. The human survivors of a post-apocalyptic zombie outbreak fought for their lives throughout the series. Assembled from components used for background performers' costumes, this set consists of three shirts and three pairs of trousers of various sizes, styles, fabrics, colors, and brands. Also included are two Certificates of Authenticity from the series' October 2022 liquidation sale, both signed by an AMC representative. The components exhibit visible signs of production use throughout, including pilling to dark blue jeans, staining and rolled sleeves on the beige shirt, and creasing throughout.

**Estimate: \$600 - 1,200**

**1456**  
The Murderer's Bear Figurine and Purses  
**The Walking Dead (2010-2022)**

The Murderer's bear figurine and purses from AMC's post-apocalyptic television series The Walking Dead. In the Season 4 episode "Dead Weight," the Governor's (David Morrissey) team found two bodies and their possessions in the cabin of a dead man who labeled himself "Murderer." This lot consists of a faux plaster bear figurine hand-painted brown emulating fur on a black display base, and two brown leather handbags, one with elephant patterns and one with metal studs engraved with Southwestern patterns. The bear exhibits paint scuffing throughout, and the leather exhibits cracking from production. Dimensions: 17" x 15" x 12" (43.25 cm x 38.25 cm x 30.5 cm)

**Estimate: \$500 - 1,000**



**1458**  
Production-Used Empty Film Cans  
**The Walking Dead (2010-2022)**

Production-used empty film cans from AMC's post-apocalyptic television series The Walking Dead. The series followed zombie apocalypse survivors, where their enemies weren't always zombified. This pair of bronze-color metal film canisters were formerly production-used in the storage and transport of chemical film reels. A Kodak technical decal is inlaid in the center of each with a printed and hand-written technical detail tag by Stalwart Films LLC taped atop each, featuring printed artwork and the show logo. The opposite canister sides feature Kodak instructional and disclaimer decals. They exhibit minor wear from use. Dimensions: 14.5" x 7.25" x 1.25" (37 cm x 18.5 cm x 3.25 cm)

**Estimate: \$600 - 1,200**



**1460**  
Set of Season 2 Episodes "Better Angels" and "Beside the Dying Fire" Production Ephemera  
**The Walking Dead (2010-2022)**

Ephemera relating to Season 2's final episodes "Better Angels" and "Beside the Dying Fire" from AMC's post-apocalyptic series The Walking Dead. Rick Grimes (Andrew Lincoln) killed Shane Walsh (John Bernthal); Carl's (Chandler Riggs) gunshot forced them to flee to a nearby prison for shelter. This lot features 34 sets of printed production documentation including watermarked call sheets, schedules, and information packets; one brass bullet shell casing; one spent plastic red shotgun shell casing; one distressed cotton jumpsuit; one rubber walker mask with brown faux hair; and two metal barbed wire pieces. The lot exhibits edge wear, creasing, discoloration, staining, scuffing, a melted mask, and grime. Dimensions: 20" x 20" x 10" (50.75 cm x 50.75 cm x 25.5 cm)

**Estimate: \$2,000 - 4,000**



**1459**  
Set of Season 2 Episodes "18 Miles Out" and "Judge, Jury, Executioner" Production Ephemera  
**The Walking Dead (2010-2022)**

Ephemera from Season 2's episodes "18 Miles Out" and "Judge, Jury, Executioner" from AMC's post-apocalyptic television series The Walking Dead. Rick Grimes' (Andrew Lincoln) and Shane Walsh (John Bernthal) found themselves at odds over Randall's (Michael Zegen) fate, with a distressed Dale Horvath (Jeffrey DeMunn) meeting his fate. This lot features 27 printed, staple-bound call sheets with sides featuring watermarked pages for various crew members; one weighted, yellow nylon T-shaped performer's spot marker; one brass bullet shell casing; one spent plastic red shotgun shell casing; and one wedge-shaped production-used makeup sponge. The lot exhibits edge wear, creasing, scuffing, fabric disintegration, and grime. Dimensions: 8.5" x 12" x 2" (21.5cm x 30.5 cm x 5 cm)

**Estimate: \$2,500 - 5,000**



**1461**  
Set of Season 2 Episodes "What Lies Ahead" thru "Pretty Much Dead Already" Production Ephemera  
**The Walking Dead (2010-2022)**

Ephemera from Season 2's episodes "What Lies Ahead" through "Pretty Much Dead Already" from AMC's post-apocalyptic television series The Walking Dead. Rick Grimes' (Andrew Lincoln) group was waylaid and rerouted to Hershel Green's (Scott Wilson) farm. This lot features 35 printed, staple-bound call sheets with sides featuring watermarked pages for various crew members; two laminated cast and crew temporary signage posted in Hershel's house; one weighted, dark purple nylon T-shaped performer's spot marker; one brass bullet shell casing; one spent plastic red shotgun shell casing; and a metal barbed wire section of Hershel's farm fence. The lot exhibits edge wear, creasing, scuffing, fabric disintegration, and grime. Dimensions: 8.5" x 12" x 0.5" (21.5cm x 30.5 cm x 1.25 cm)

**Estimate: \$1,500 - 3,000**



**1462**  
Set of Season 2 Episodes "Nebraska" and "Triggerfinger" Production Ephemera  
**The Walking Dead (2010-2022)**

Ephemera relating to the Season 2 episodes "Nebraska" and "Triggerfinger" from AMC's post-apocalyptic television series The Walking Dead. Actions by members of Rick Grimes' (Andrew Lincoln) group revealed that Hershel Green's (Scott Wilson) had zombies locked in a barn. This episodic lot features 12 printed, staple-bound call sheets with sides, each featuring watermarked pages for various crew members; one weighted, orange nylon and taped T-shaped performer's spot marker; one production-used makeup brush with a black plastic handle; and a metal barbed wire section of Hershel's farm fence. The lot exhibits edge wear, creasing, scuffing, and dirt marks. Dimensions: 20" x 20" x 2" (50.75 cm x 50.75 cm x 5 cm)

**Estimate: \$1,200 - 2,400**

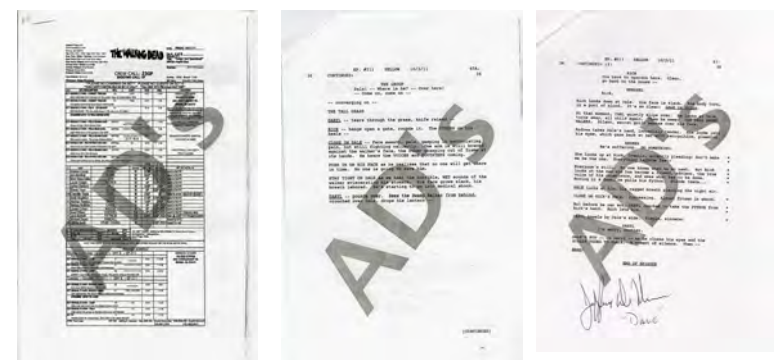

**1464**  
Jeffrey DuMunn-Autographed "Judge, Jury, Executioner" Day 4 Call Sheet  
**The Walking Dead (2010-2022)**

Jeffrey DuMunn-autographed "Judge, Jury, Executioner" day 4 call sheet from AMC's post-apocalyptic television series The Walking Dead. Dale Horvath (DuMunn) was ambushed and disemboweled by a walker, and was later mercy-killed by Daryl Dixon (Norman Reedus) at the end of the episode. This stapled, 10-page assistant director's call sheet features the large, diagonal "AD's" watermark on each page, with the last script page autographed and hand-marked "Dale" by DeMunn in black pen. The sheets exhibit creasing and edge wear. Dimensions: 8.5" x 5.75" x 0.25" (21.75 cm x 14.75 cm x 0.75 cm)

**Estimate: \$400 - 800**



**1463**  
Negan Smith's (Jeffrey Dean Morgan) House Blueprint  
**The Walking Dead (2010-2022)**

A blueprint of Negan Smith's (Jeffrey Dean Morgan) house from AMC's horror series The Walking Dead. In a flashback in the Season 10 episode "Here's Negan," Negan burned his house to the ground after his wife, Lucille (Hilarie Burton), turned herself into a Walker. This production blueprint labeled "Int and Ext Negans House" and featuring the "TWD" production logo was designed by production designer Marek Dobrowolski and art director Matthew C. Jacobs. It is dated "September 15, 2020" and features a floor plan, front elevation scales, and pictures of window planks. The blueprint exhibits creasing from being rolled for storage. Dimensions: 24.5" x 36" (62.25 cm x 91.5 cm)

**Estimate: \$600 - 1,200**



**1465**  
Collection of Barrington Hilltop House Components with Ephemera  
**The Walking Dead (2010-2022)**

Barrington Hilltop House components with ephemera from AMC's horror series The Walking Dead. The Barrington Hilltop House first appeared in Season 6's "Knots Untie." This lot consists of two bricks; a roof shingle; hanging lamp; lightswitch plate with connector; doorknob; lock; rusty horseshoe; rusty spoon and fork; rusty tools; two sets of grommet curtains; twine; and reflective cap. Also included are stones from Glenn Rhee's (Steven Yeun) and Sasha Williams' (Sonequa Martin-Green) graves, as well as a USB card with pictures from set demolition, and five production papers for crew call and designated areas. Production intentionally distressed these items to appear aged. This lot exhibits discoloration. Dimensions: 24" x 16" x 10" (61 cm x 40.5 cm x 25.5 cm)

**Estimate: \$1,200 - 2,400**



**1466**  
Medivh's (Ben Foster) Book  
**Warcraft (2016)**

Medivh's (Ben Foster) book from Duncan Jones' action-fantasy film Warcraft. Medivh kept many books and tomes in his library at Karazhan. This black, leather-bound book features silver-color painted metal accents and blue acrylic faux sapphires along the spine. Some of the pages feature black and blue markings and include 10 loose pages with foreign language passages and diagrams. This lot exhibits intentional distressing along the paper edges and cover from production. Dimensions: 11" x 14" x 3" (36 cm x 28 cm x 8 cm)

**Estimate: \$4,000 - 8,000**



**1467**  
Khadgar's (Ben Schnetzer) Funeral Robe Costume  
**Warcraft (2016)**

Khadgar's (Ben Schnetzer) funeral robe costume from Duncan Jones' action-fantasy film Warcraft. Khadgar wore his robes during the funeral of King Llane and was unseen in the final version of the film. This lot consists of a light brown polyester blend and silk robe; a light brown and blue polyester blend and blue silk hooded vest; a light brown and blue polyester blend belt; and an off white polyester blend undershirt.

**Estimate: \$3,000 - 6,000**



**1468**  
Young Medivh's (Tommy Rieder) Robe  
**Warcraft (2016)**

Young Medivh's (Tommy Rieder) robe from Legendary Pictures' fantasy epic Warcraft. Medivh wore his ceremonial robe as a child in a deleted scene. This lot consists of a patterned, glossy gray and brown satin and cotton robe with a knotted tie closure at front; a matching tunic with snap button closures on front; matching satin trousers; a double-knotted, off-white satin belt; and a pair of metal-studded leather high-heeled boots. The costume exhibits visible crinkling and some nicks to the leather from production wear.

**Estimate: \$2,000 - 4,000**



**1469**  
Elf Soldier Uniform  
**Warcraft (2016)**

An Elf soldier uniform from Legendary Pictures' fantasy epic Warcraft. Elf soldiers wore their uniforms as they debated the best methods to fight the impending attacks of the Orc Horde. This lot consists of a teal polyester tunic with gold-color lame stitching and scale-like plastic details; a matching skirt and trousers, both marked "264"; a gray woven leather cuirass inset with teal resin gems marked "255"; and a pair of matching vambraces with matching plated boots and spats marked "135." The leather components exhibit intentional distressing by production to appear battle-worn.

**Estimate:**  
**\$2,000 - 4,000**



**1470**  
Pair of Stormwind Castle  
Decor Shields  
**Warcraft (2016)**

Pair of Stormwind castle decor shields from Duncan Jones' action-fantasy film Warcraft. Decorative shields hung in Stormwind Castle throughout the film. This lot consists of two blue and silver-color painted urethane shields featuring embossed lion heads and metal wiring on the reverse for hanging. This lot exhibits scuffing and chipping paint from production use. Dimensions: 25" x 22" x 6" (63.5 cm x 56 cm x 15.5 cm)

**Estimate:**  
**\$2,000 - 4,000**



**1473**  
Elf Delegate Uniform  
**Warcraft (2016)**

An Elf delegate uniform from Legendary Pictures' fantasy epic Warcraft. Elf delegates wore their costumes when they debated how to fight against the Orc Horde. This lot consists of a green polyester shoulder yoke marked "153" by production with gold-color foam detailing and a green resin gem at center; a matching polyester shirt marked "Elf Delegate BG"; a matching polyester overskirt marked "Elf Delegate BG 153"; a matching underskirt marked "Timothy Knight"; matching trousers; two gold-color leather vambraces labeled "Elf 2" and "153"; two matching metal armbands; and two matching leather boots (U.S. men's size 11.5) with spats marked "Greenfire 153." The foam exhibits cracking and the gold-color components exhibit green discoloration from age.

**Estimate:**  
**\$2,000 - 4,000**



**1474**  
Alliance Royal Guard  
Urethane Blade Sword  
and Sheath  
**Warcraft (2016)**

An Alliance royal guard urethane blade sword and sheath from Duncan Jones' action-fantasy film Warcraft. Royal Guards were armed with swords while guarding King Llane in Stormwind. This lot consists of a dense urethane sword painted silver-color to resemble a metallic shine with carved designs along the blade; a dark gray painted lion sculpted handguard with a blue acrylic faux sapphire and a matching dark gray painted sculptedommel; a navy-painted handle sculpted and textured to resemble leather accents; a blue dense urethane sheath with designs carved along the shaft, a silver-color painted tip and embellishments to resemble a metallic shine and a light blue acrylic faux sapphire. This lot exhibits minor scuffs and discoloration from production use. Dimensions: (sword) 46" x 10" x 5" (117 cm x 25.5 cm x 12.75 cm); (sheath) 30" x 10" x 5" (76.25 cm x 25.5 cm x 12.75 cm)

**Estimate:**  
**\$2,000 - 4,000**



**1471**  
Alliance Shield  
**Warcraft (2016)**

An Alliance shield from Duncan Jones' action-fantasy film Warcraft. Alliance forces used their shields in battles against the Orc Horde. This blue- and silver-painted urethane shield features a sculpted lion's head with foreign language carved along the bottom and a leather padding on the back. This lot exhibits scuffs and chipping from production. Dimensions: 39.5" x 21.75" x 6.25" (100.5 cm x 55.5 cm x 16 cm)

**Estimate:**  
**\$2,000 - 4,000**



**1472**  
Alliance Gold Lion Shield  
**Warcraft (2016)**

An Alliance gold lion shield from Duncan Jones' action-fantasy film Warcraft. An Alliance knight used his gold lion shield to defend against an orc attack at the beginning of the film. This urethane shield features a gold-painted sculpted lion's head with a blue-painted background, silver-painted trim, and a brown leather backing. This shield exhibits distressing from production and is missing the leather arm straps. Dimensions: 39" x 22" x 7.5" (99 cm x 56 cm x 19 cm)

**Estimate:**  
**\$2,000 - 4,000**



4.4' (1.35m)

**1475**  
Frostwolf Ax  
**Warcraft (2016)**

A Frostwolf ax from Legendary Pictures' video game adaptation Warcraft. Orcs of the Frostwolf clan used a variety of hand-crafted weapons in battle, including axes. Though many props in the film were created digitally, physical props were created for lighting reference and texture mapping. This lot consists of a dense urethane and foam ax wrapped in leather and faux fur with a Frostwolf emblem on the head and a small skull and hair embellishment on the bottom of the handle. It exhibits some wear from use, including minor dents in the urethane and foam. Dimensions: 53" x 24" x 5.25" (135 cm x 61 cm x 13.5 cm)

**Estimate:**  
**\$2,000 - 4,000**



**1476**  
Set of Three Alliance  
Halberds  
**Warcraft (2016)**

Three Alliance halberds from Legendary Pictures' fantasy epic Warcraft. Soldiers of the Alliance wielded their halberds in battle against the Orc Horde. Each of these halberds features a wooden staff mounted on top with a dense urethane blade hand-painted in the Alliance's signature silver-color and blue and engraved on both sides with gold-color Stormwind lion emblems. The set exhibits some paint flaking and cracking to the blades from age and production use. Dimensions (each): 97" x 20" x 9" (246.5 cm x 51 cm x 23 cm) Special shipping required; see notice in the Buyer's Guide.

**Estimate:**  
**\$1,500 - 3,000**





**1477**  
Lordaeron Battle Banner  
**Warcraft (2016)**

A Lordaeron battle banner from Duncan Jones' action-fantasy film *Warcraft*. Lordaerons' banners were made by production but were unused in the final film. This banner is made of gray polyester-cotton with a gold-color vinyl emblem and trim, mounted on an aluminum metal pole with gold-color decorative balls. This lot exhibits creases in the fabric from storage and one of the balls is broken from the pole. Dimensions: 142.5" x 40.75" x 4.5" (362 cm x 103.5 cm x 11.5 cm) Special shipping required; see notice in the Buyer's Guide.

**Estimate: \$1,200 - 2,400**



**1478**  
Elven Staff  
**Warcraft (2016)**

An Elven staff from Legendary Pictures' fantasy epic *Warcraft*. Staffs of this style were made by production for Elven soldiers to wield, but were ultimately unseen in the final cut. This foam staff features a spike engraved with Elven runes, painted steel-color, and mounted to a faux wooden staff painted black. The spike exhibits cracking paint, exposing the foam, and bending to its points from production use. Dimensions: 76" x 9" x 2" (193 cm x 23 cm x 5 cm) Special shipping required; see notice in the Buyer's Guide.

**Estimate: \$800 - 1,600**



**1479**  
Varian Wrynn's (Dylan Schombing)  
Stormwind Costume Components  
**Warcraft (2016)**

Varian Wrynn's (Dylan Schombing) Stormwind costume components from Legendary Pictures' fantasy epic *Warcraft*. Wrynn, the son of King Llane (Dominic Cooper), wore his Stormwind costume in a scene ultimately unseen in the final cut. These components consist of a floral-patterned black cotton blend tunic with brown leather detailing, metal buckle closures down the front, and a faux gold Stormwind lion brooch affixed to the front right lapel, as well as a royal blue cotton and satin blend tunic with beige leather details on the cuffs. The leather exhibits fraying and the tunic exhibits pilling from production wear.

**Estimate: \$800 - 1,600**



**1480**  
Alliance Knight Armor with Poleaxe  
**Warcraft (2016)**

Alliance knight armor with a poleaxe from Duncan Jones' action-fantasy film *Warcraft*. Alliance Knights wore their armor while in battle throughout the film. This silver- and gold-painted resin and plastic armor features: a helmet with blue dyed synthetic hair; a blue-painted cuirass with brown leather straps; a sculpted lion leather belt; a pair of sculpted lion vambraces with brown leather straps; brown leather gloves; brown leather boots; a blue polyester blend and gold-color trim skirt; a silver-color aluminum chainmail tunic (size 40); a blue polyester blend shirt and trousers; and a silver-color and brown-painted dense foam sculpted poleaxe with blue cloth wrapping. This lot exhibits discoloration throughout. Dimensions: (poleaxe) 93" x 28" x 25" (236.25 cm x 71.25 cm x 63.5 cm) Special shipping required; see notice in the Buyer's Guide.

**Estimate: \$8,000 - 16,000**



**1481**  
R's Distressed Hoodie and T-Shirt  
**Warm Bodies (2013)**

R's distressed hoodie and T-shirt from Jonathan Levine's romantic zombie comedy *Warm Bodies*. R wore his post-apocalyptic zombie costume throughout the film. This lot consists of a red cotton hoodie hand-marked "After Wash and Squibb" on the inner label, and an off-white cotton T-shirt hand-marked "stunt 2" on the collar's interior. Production distressed these components with holes, tears, and grime to appear post-apocalyptic. This lot exhibits fragility on the shirt collar and the hoodie's drawstrings.

**Estimate: \$1,500 - 3,000**



**1482**  
Andrew Neiman's (Miles Teller) Tom  
Drum  
**Whiplash (2014)**

Andrew Neiman's (Miles Teller) tom drum from Damien Chazelle's psychological drama *Whiplash*. Neiman, an ambitious jazz drum student at Shaffer Conservatory, played his drums throughout the film while learning under the abusive Terence Fletcher (J. K. Simmons). This drum, while from production, was ultimately unseen on screen. This lot consists of a floor tom with a wooden shell featuring a glossy burgundy finish, metal tension rods, a decal reading "Force," and a white drumhead. The finish exhibits scratching and the head exhibits extensive scuff marks from drumming. Dimensions: 13.5" x 13.5" x 12" (34.5 cm x 34.5 cm x 30.5 cm)

**Estimate: \$1,000 - 2,000**



**1483**  
**Framed Hand-Drawn Richard Williams Toontown Artwork**  
**Who Framed Roger Rabbit (1988)**

Framed Toontown artwork hand-drawn by Richard Williams, the animation director of Robert Zemeckis' Oscar®-winning detective comedy Who Framed Roger Rabbit. Roger Rabbit (Charles Fleischer) and his fellow cartoon characters resided in LA's Toontown. This artwork depicting Roger holding a "Toontown Ltd." sign is rendered and signed "XX Bob! From Dick W," possibly to director Zemeckis, in mixed media on paper. It comes framed behind glass in a black metal frame. The paper exhibits some creasing and stain marks, and the frame exhibits several dings. Dimensions: 15.75" x 12.75" x 0.75" (40 cm x 32.5 cm x 2 cm) Sold without copyright; see notice in the Buyer's Guide.

**Estimate: \$3,000 - 6,000**

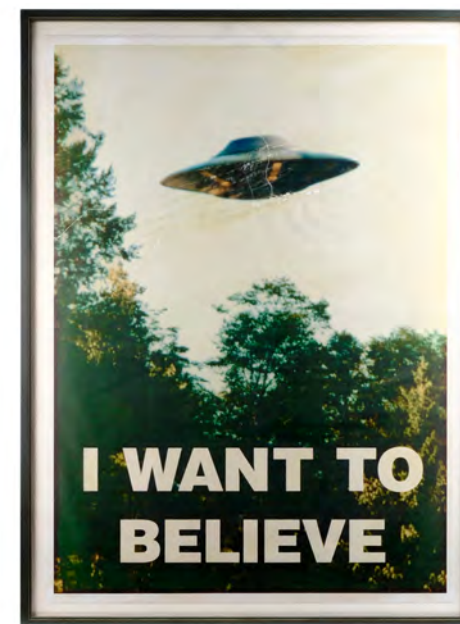

**1485**  
**Framed Distressed "I WANT TO BELIEVE" Poster**  
**The X-Files (1993-2018)**

A distressed "I WANT TO BELIEVE" poster from Chris Carter's 2016 sci-fi event series reboot The X-Files. In the Season 10 premiere "My Struggle," Murder stepped on one of his memorable "I WANT TO BELIEVE" posters while exploring his former office in a nod to the original series. After production, the distressed poster was mounted inside a custom black frame with a metal hanging wire on the reverse for display. This color-printed paper poster with an image of a flying saucer and the phrase "I Want To Believe" below is intentionally distressed by production with dirt marks, scuffing around the UFO, and creases throughout. The paper also exhibits signs of attempted repair. Dimensions: 26.5" x 36" x 1" (67.5 cm x 91.5 cm x 3 cm)

**Estimate: \$3,000 - 6,000**



**1486**  
**Set of 206 Continuity Polaroids and Photos**  
**The Legend Of Zorro (2005)**

A set of 206 continuity polaroids and photos from Martin Campbell's romantic adventure The Legend of Zorro. Continuity photos were used to maintain consistency in the costumes characters wore throughout the film. This lot consists of 206 color continuity polaroids and photos of the characters in their costumes from various angles. Some of these polaroids feature hand-written notes from production. This lot exhibits grime from age and production use. Dimensions: (each polaroid) 4" x 4" (10.25 cm x 10.25 cm); (each photo) 4" x 6.5" (10.25 cm x 16.5 cm)

**Estimate: \$400 - 800**



**1484**  
**First Draft Script**  
**Who Framed Roger Rabbit (1988)**

A first draft script from Robert Zemeckis' Oscar®-winning detective comedy Who Framed Roger Rabbit. Written by Babloo Mandel and Lowell Ganz, this yellow cardstock cover bound 121-page first draft is dated January 23, 1984. It features a note from the writers explaining the film as having animation and live-action; concept designs for characters such as Roger, Jessica, and baby Herman; and includes 10 printed storyboards throughout. It exhibits a stain splatter on the front cover, a torn label, and a loose first page. Dimensions: 9" x 11.5" x 1" (23 cm x 29.25 cm x 2.75 cm)

**Estimate: \$1,000 - 2,000**



**1487**  
**Elena de la Vega's (Catherine Zeta-Jones) Necklace**  
**and Gift Box**  
**The Legend Of Zorro (2005)**

Elena de la Vega's (Catherine Zeta-Jones) necklace and gift box from Martin Campbell's adventure-romance film The Legend of Zorro. Elena received a necklace from Count Armand (Rufus Sewell) as he proposed to her. This lot consists of a faux pearl necklace featuring a metal and rhinestone bow ornament with a teardrop shaped faux pearl and a black wooden box with a black velvet lining. This lot exhibits tarnishing on the pendant, scuffing on the box, and a loose strand. Dimensions: (box) 11" x 8" x 2" (28 cm x 20.5 cm x 5 cm)

**Estimate: \$800 - 1,600**

## Buyer's Guide

### 1. Introduction

This Buyer's Guide contains a brief overview of Propstore's auction process and the terms under which Lots are made available for sale at auction. A more detailed statement of our Terms and Conditions of Sale follow after this Buyer's Guide. Please read the Buyer's Guide and the Terms and Conditions of Sale carefully. By registering to bid and participate in a Propstore auction, you will be deemed to have agreed to be bound by them.

### 2. Definitions

2.1. When the following words are used in this Buyer's Guide, they mean:

<b>Auction</b>	A live sale by auction hosted by Propstore
<b>Bidder</b>	Any person, properly registered and approved by Propstore to participate in an Auction who makes or considers making a bid to buy a Lot at Auction
<b>Buyer</b>	The person or Company making the highest bid or offer for a Lot accepted by the auctioneer, including a principal bidding as agent
<b>Buyer's Expenses</b>	A fee of 5% of the Hammer Price charged to the Buyer for a Lot won on any bidding platform other than propstoreauction.com
<b>Buyer's Premium</b>	A commission of 25% of the Hammer Price charged to the Buyer for a Lot
<b>Company</b>	Any partnership, corporation, limited liability company, association, or any other business entity duly organized and qualified to conduct business under the laws of its state of formation
<b>Credit Card Fee</b>	A fee of 2% of the Purchase Price applied to any orders paid via credit card where the Purchase Price is greater than \$5,000.
<b>Cryptocurrency</b>	Cryptocurrency means the virtual or digital currency accepted by Prop Store as payment, using our chosen payment processor. The current list of the forms of Cryptocurrency we accept are set out on our website at propstore.com/cryptocurrency
<b>Guarantee of Attribution</b>	Propstore's limited guarantee relating to the provenance of each Lot, as set forth in Paragraph 6 of the Terms and Conditions of Sale
<b>Hammer Price</b>	The highest bid for a Lot accepted by the auctioneer at the Auction
<b>Lot</b>	Each item or group of items consigned by the Seller to Propstore to be made available for sale at an Auction, as detailed in the catalog
<b>Propstore</b>	The Prop Store of London, Inc., d/b/a Propstore, of 28014 Harrison Pkwy, Valencia, CA 91355
<b>Purchase Price</b>	The Hammer Price plus the Buyer's Premium, any applicable Buyer's Expenses, applicable Credit Card Fee, and any applicable sales tax charged to the buyer.
<b>Seller</b>	The person or Company offering the Lot for sale, including their agents or personal representatives
<b>Terms and Conditions of Sale</b>	Propstore's Terms and Conditions of Sale at Auction, from time to time as may be amended, a copy of which appears following the Buyer's Guide

### 3. Before the Auction

#### 3.1. Bidder Registration

- 3.1.1. Every person or Company wishing to make a bid in the Auction is required to register with Propstore before participating at an Auction.
- 3.1.2. To register, each person or Company must complete and return a bidder registration form available in this Buyer's Guide or online at www.propstore.com, which must include valid Visa, MasterCard or American Express credit card details to be held on file.
  - 3.1.2.1. Each Company registering to bid must provide a certified copy or original articles of incorporation, articles of organization, or other documents satisfactory to Propstore - contact Propstore at +1 818 727 7829 for confirmation of what will be acceptable.
  - 3.1.2.2. Any person seeking to participate in the Auction as an agent on behalf of a registered principal must complete and submit an Agent Information Form, and provide an up-to-date, valid government-issued photo identification (e.g. passport, driver's license), as well as a written authorization from the principal confirming the agent's authority to participate at the Auction on the principal's behalf.

#### 3.2. Pre-Auction Viewing

- 3.2.1. During the Pre-Auction Viewing period, as set forth in the Auction catalog, any Bidder may preview Lots with Propstore. Viewing by appointment may also be possible outside of the Pre-Auction Viewing period.

#### 3.3. Shipping Charge Estimates

- 3.3.1. At Bidder's request, without any liability therefore, Propstore can provide shipping estimates before the Auction. Bidders requesting this information should email support@propstore.com including the Lot number and shipping address at least 3 days before the start of the Auction. Real-time shipping estimates are also available on many lots through the online bidding platform. Bidders should be aware that oversize lots may be expensive to ship and inquire for a quote before bidding on these items. Estimates are provided as a courtesy to bidders, cannot be guaranteed, and in all cases, Buyer will be responsible for associated shipping costs as per section 5.3 of the Terms and Conditions. Winning bids are legally binding and must be paid regardless of final shipping expenses.

#### 3.4. Bidders outside the US

- 3.4.1. If the Bidder is located outside the United States, it is the Bidder's sole responsibility and obligation to ensure in advance of the Auction that any Lot purchased in the Auction can be exported from the United States and imported into the country of destination. No sale will be canceled because the Lot may not be imported into the country of destination.
- 3.4.2. PackAir Airfreight, Inc., a third-party independent freight vendor, can advise Bidders on relevant export licensing regulations and may submit export license applications upon request. Neither Propstore nor PackAir Freight, Inc. can guarantee that any licenses, permits or consents will be granted, and shall have no liability arising out of or relating thereto.

## Buyer's Guide

### 4. At the Auction

#### 4.1. Estimates

- 4.1.1. Estimates represent Propstore's guide to Bidders and do not give any indication or representation of actual values or likely bids. Estimates do not include any Buyer's Premium, Buyer's Expense or sales tax.
- 4.1.2. Propstore reserves the right to amend its estimates from time to time.

#### 4.2. Reserve Price

- 4.2.1. Certain Lots in this auction may be sold without a Reserve Price; the majority of Lots in this auction are sold with a Reserve Price. The Reserve Price is the minimum price the Seller will accept for a Lot. The Reserve Price will not be more than the lowest estimate given by Propstore. Propstore may disclose or keep confidential the Reserve Price at its entire discretion.

#### 4.3. Bidding Process

- 4.3.1. All bids are by individual Lot unless the auctioneer states to the contrary during the live Auction. Lots will usually be sold in their numbered sequence, unless the auctioneer announces otherwise at the Auction.
- 4.3.2. The auctioneer may accept bids from Bidders present in the sale room, via telephone, or via online at the time of the Auction. The auctioneer may also accept proxy bids delivered to Propstore before the start of the Auction. Proxy bids may be submitted either by using the form in this Buyer's Guide or the online form at www.propstore.com. Proxy bids will be executed at the lowest possible price.
- 4.3.3. Any Bidder wishing to place bids at the time of the Auction via telephone must provide to Propstore a list of Lots on which they intend to bid at least 24 hours before the start of the Auction.
- 4.3.4. In addition to Propstore's Terms and Conditions of Sale, any Bidder placing bids online must comply with the terms for use of the online auction platform access provider.
- 4.3.5. Except as expressly stated in this Buyer's Guide or the Terms and Conditions of Sale, Propstore shall have no liability arising out of or related to any errors or omission in respect of bids made online, by telephone or by proxy.
- 4.3.6. The auctioneer shall have sole discretion to accept or decline any bid.

### 5. After the Auction

#### 5.1. Payment

- 5.1.1. Propstore will notify the Buyer and send (by email unless requested otherwise) a payment invoice setting out the Purchase Price and itemizing the Hammer Price, Buyer's Premium, plus any applicable Buyer's Expense or sales tax, within 7 business days of the end of the Auction. Sales tax, as required by law, shall be applied at the state's prevailing rate when being shipped to the following states:

Arizona	California	Colorado	Florida	Georgia	Illinois	Indiana	Kansas	Louisiana	Maryland	Massachusetts	Michigan
Minnesota	New Jersey	New York	North Carolina	Ohio	Pennsylvania	Texas	Utah	Vermont	Virginia	Washington	Wisconsin

If you are shipping goods to any of these states, state and local sales tax will be calculated and added to your order based on your address. Propstore charges sales tax in accordance with the individual state requirements; therefore additional states may become taxable for purchases from Propstore at any time. Buyers are encouraged to check with Propstore prior to bidding if they have questions about the sales tax status of potential purchases.

- 5.1.2. Unless you have been approved for a payment plan as set forth in Paragraph 5.1(c) of the Terms and Conditions of Sale, payment of the invoice is due within 7 business days from receipt of the invoice and must be made by the Buyer. Payments from any other source will not be accepted and shall be returned by Propstore.

- 5.1.3. Payment must be in US dollars and may be made by electronic transfer, debit card, credit card (up to a maximum of \$25,000), banker's draft or check (drawn on a US bank account - note check clearance can take between 5 and 10 working days), or cash (up to a maximum of \$5,000. Please quote the Lot number, invoice number and Bidder registration number when making payment to ensure it can be processed as efficiently as possible.

- 5.1.4. If payment is made by credit card, Buyer expressly agrees that such payment is nonrefundable nor may be credited to any other purchase, and that Buyer will not undertake any action or effort to stop payment, seek a refund, or attempt a charge back of such amounts by the issuer of the credit card.

- 5.1.5. Cryptocurrency payments are accepted via our payment processor (Bitpay), as indicated at checkout. You must pay for the entire balance owed including the Purchase Price and any other relevant charges entirely in one form of Cryptocurrency and you should ensure you have a sufficient balance to pay for all sums owed. We do not accept partial payment by Cryptocurrency and a different form of payment in one transaction. Cryptocurrency payment is only acceptable on the express understanding that the Lot is not returnable, refundable nor exchangeable. Buyers paying with Cryptocurrency are also not eligible to use payment plans. We reserve the right to exclude the use of payment by Cryptocurrency on certain Lots, such exclusion to be noted on the listing.

#### 5.2. Shipping and Storage

- 5.2.1. The Buyer is solely responsible for all shipping, handling, and delivery costs. Propstore can help you arrange packing and shipping through FedEx or USPS for smaller items or PackAir AirFreight, Inc. for larger items, or you can use your own licensed carrier, approved by Propstore. Please contact Propstore at +1 818 727 7829 for further details. Propstore does not warranty the Lots against and shall have no liability for any damage that any Lot may incur or suffer during the shipping or delivery process. Propstore offers insurance for shipments in transit at an additional charge; buyers will have an option to select this when finalizing your purchase after auction. Bidders should be aware that oversize lots may be expensive to ship and inquire for a quote before bidding on these items; also be aware that certain lots, as indicated, are stored separate to Propstore's primary facility and shipping charges on these pieces may vary accordingly. Winning bids are legally binding and must be paid regardless of final shipping expenses.

- 5.2.2. After 30 days after close of Auction, if Buyer has not made arrangements for and paid the shipping cost of the Lots purchased, or has otherwise failed to collect the Lots, Propstore may impose a storage fee of 3% of the Hammer Price per month to be charged to the Buyer. After 14 days after close of Auction, if Buyer has not made arrangements for and paid the shipping cost of the Lots purchased, or has otherwise failed to collect the Lots, a storage fee of 3% of the Hammer Price per month shall be charged to the Buyer. If the Buyer has failed to pay the Purchase Price and the cost of shipping and handling, Propstore, at its option may cancel the sale.

## Terms & Conditions

These Terms and Conditions of Sale (“Conditions”) set out the agreement between the Bidder/Buyer and Propstore and the Seller. By registering to bid and participate in a Propstore Auction, you will be deemed to have read and agreed to be bound by these Conditions and the accompanying Buyer’s Guide, as set forth in the catalog for the Auction and online at [www.propstore.com](http://www.propstore.com).

In the event of any conflict between the Conditions and the Buyer’s Guide, the Conditions shall take precedence.

### 1. Definitions

When the following words are used in this Buyer’s Guide, they mean:

<b>Auction</b>	A live sale by auction hosted by Propstore
<b>Bidder</b>	Any person, properly registered and approved by Propstore to participate in an Auction who makes or considers making a bid to buy a Lot at Auction
<b>Buyer</b>	The person or Company making the highest bid or offer for a Lot accepted by the auctioneer, including a principal bidding as agent
<b>Buyer’s Expenses</b>	A fee of 5% of the Hammer Price charged to the Buyer for a Lot won on any bidding platform other than <a href="http://propstoreauction.com">propstoreauction.com</a>
<b>Buyer’s Guide</b>	Propstore’s Buyer’s Guide, from time to time as may be amended, a copy of which appears in the catalog for the Auction and online at <a href="http://www.propstore.com">www.propstore.com</a>
<b>Buyer’s Premium</b>	A commission of 25% of the Hammer Price charged to the Buyer for a Lot
<b>Company</b>	Any partnership, corporation, limited liability company, association, or any other business entity duly organized and qualified to conduct business under the laws of its state of formation
<b>Credit Card Fee</b>	A fee of 2% of the Purchase Price applied to any orders paid via credit card where the Purchase Price is greater than \$5,000.
<b>Cryptocurrency</b>	Cryptocurrency means the virtual or digital currency accepted by Prop Store as payment, using our chosen payment processor. The current list of the forms of Cryptocurrency we accept are set out on our website at <a href="http://propstore.com/cryptocurrency">propstore.com/cryptocurrency</a>
<b>Guarantee of Attribution</b>	Propstore’s limited guarantee relating to the provenance of each Lot, as set forth in Paragraph 6 of the Terms and Conditions of Sale
<b>Hammer Price</b>	The highest bid for a Lot accepted by the auctioneer at the Auction
<b>Lot</b>	Each item or group of items consigned by the Seller to Propstore to be made available for sale at an Auction, as detailed in the catalog
<b>Propstore</b>	The Prop Store of London, Inc., d/b/a Propstore, of 28014 Harrison Pkwy, Valencia, CA 91355
<b>Purchase Price</b>	The Hammer Price plus the Buyer’s Premium, any applicable Buyer’s Expenses, applicable Credit Card Fee, and any applicable sales tax charged to the buyer.
<b>Seller</b>	The person or Company offering the Lot for sale, including their agents or personal representatives

### 2. Catalog Descriptions and Conditions of Lots

- 2.1. All Lots are sold subject to their condition at the date of the Auction. The nature and age of the Lots mean they are often unique and are likely to have wear and tear, damage and other imperfections. By making a bid, the Bidder accepts the actual condition of the Lot and acknowledges that if a bid is successful, the Buyer will buy the Lot “as is”.
- 2.2. Propstore’s staff are not professional restorers so descriptions of Lots, images and statements of condition in Propstore’s catalog or on its website are for illustrative purposes only. Propstore cannot guarantee that colors are properly shown. Save for Propstore’s Terms of Guarantee of Attribution, all Lots are sold “as is”. Bidders are encouraged to inspect Lots and satisfy themselves as to their condition before bidding, seeking and obtaining independent professional advice where required.
- 2.3. Condition reports are available for each Lot upon request.

### 3. Before the Auction

- 3.1. Bidder Registration
  - 3.1.1. Every person or Company wishing to make a bid in the Auction is required to register with Propstore before participating at an Auction.
  - 3.1.2. To register, each person or Company must complete and return a bidder registration form available in this Buyer’s Guide or online at [www.propstore.com](http://www.propstore.com), which must include a valid Visa, MasterCard or American Express credit card details to be held on file.
  - 3.1.3. Each Company registering to bid must provide a certified copy or original articles of incorporation, articles of organization, or other documents satisfactory to Propstore – contact Propstore at +1 818 727 7829 for confirmation of what will be acceptable.
  - 3.1.4. Any person seeking to participate in the Auction as an agent on behalf of a registered principal must complete and submit an Agent Information Form, and provide an up-to-date, valid government-issued photo identification (e.g., passport, driver’s license), as well as a written authorization from the principal confirming the agent’s authority to participate at the Auction on the principal’s behalf.
  - 3.1.5. Propstore will hold all personal information provided by the Bidder at registration and the Bidder agrees and consents to such information being used by Propstore to:
    - 3.1.5.1. Ship Lots purchased at Auction to the Buyer;
    - 3.1.5.2. Process the Buyer’s payment;
    - 3.1.5.3. Conduct credit checks, as deemed necessary by Propstore in its sole discretion; and/or
    - 3.1.5.4. If the bidder opts in during registration, inform the Bidder about other auctions, products and services provided by Propstore and its affiliates (please contact Propstore by email at [enquiries@propstore.com](mailto:enquiries@propstore.com) or by phone +1 818 727 7829 if you do not wish for your information to be used for such a purpose).

## Terms & Conditions

- 3.1.6. By participating in and/or attending the Auction and signing the registration form, each Bidder consents to be filmed and/or photographed and agrees and authorizes Propstore to use and publish such film and/or photographs and likeness for use in (1) providing online access to the Auction, (2) recording the results of the Auction, (3) print, digital, online and all other media for marketing purposes (including without limitation, on Propstore’s website, YouTube and other online platforms) and (4) in any other Propstore publications of whatever nature. The Bidder releases Propstore and holds it harmless from any reasonable expectation of confidentiality or privacy associated with such images and releases Propstore and any third parties involved in the making, creation or publication of the images or any marketing or other materials derived therefrom from all and any liability for claims made in respect of such publication. Publication of the images in whatever format confers no right of ownership on the individual or right to royalties or payment.

### 3.2. Pre-Auction Viewing

- 3.2.1. During the Pre-Auction Viewing period, as set forth in the Auction catalog, any Bidder may preview Lots with Propstore. Viewing by appointment may also be possible outside of the Pre-Auction Viewing period.

### 3.3. Shipping Charge Estimates

- 3.3.1. At Bidder’s request, without any liability therefore, Propstore can provide shipping estimates before the Auction. Bidders requesting this information should email [support@propstore.com](mailto:support@propstore.com) including the Lot number and shipping address at least 3 days before the start of the Auction. Real-time shipping estimates are also available on many lots through the online bidding platform. Bidders should be aware that oversize lots may be expensive to ship and inquire for a quote before bidding on these items. Estimates are provided as a courtesy to bidders, cannot be guaranteed, and in all cases, Buyer will be responsible for associated shipping costs as per section 5.3 of the Terms and Conditions. Winning bids are legally binding and must be paid regardless of final shipping expenses.

### 3.4. Bidders Outside the US.

- 3.4.1. If the Bidder is located outside the United States, it is the Bidder’s sole responsibility and obligation to ensure in advance of the Auction that any Lot purchased in the Auction can be exported from the United States and imported into the country of destination. No sale will be canceled because the Lot may not be imported into the country of destination. PackAir Airfreight, Inc., a third-party independent freight vendor, can advise Bidders on relevant export licensing regulations and may submit export license applications upon request. Neither Propstore nor PackAir Freight, Inc. can guarantee that any licenses, permits or consents will be granted, and shall have no liability arising out of or relating thereto.

### 4. At the Auction

#### 4.1. Estimates

- 4.1.1. Estimates represent Propstore’s guide to Bidders and do not give any indication or representation of actual values or likely bids. Estimates do not include any Buyer’s Premium, Buyer’s Expenses or sales tax.
- 4.1.2. Propstore reserves the right to amend its estimates from time to time.

#### 4.2. Reserve Price

- 4.2.1. Certain Lots in this auction may be sold without a Reserve Price; the majority of Lots in this auction are sold with a Reserve Price. The Reserve Price is the minimum price the Seller will accept for a Lot. The Reserve Price will not be more than the lowest estimate given by Propstore. Propstore may disclose or keep confidential the Reserve Price at its entire discretion.

#### 4.3. Bidding Process

- 4.3.1. Propstore reserves the right to refuse admission and/or participation at the Auction and to reject any bid.
- 4.3.2. Bids may not be accepted from unregistered bidders and all Bidders must be 18 or over. All bids must be made in US dollars.
- 4.3.3. When making a bid, every Bidder acknowledges that such bid is a binding offer to buy the Lot at that price (plus the Buyer’s Premium, plus any applicable Buyer’s Expenses, applicable Credit Card Fee, all applicable taxes, and any and all shipping charges, storage fees and/or other costs).
- 4.3.4. All bids are by individual Lot unless the auctioneer states to the contrary during the live Auction. Lots will usually be sold in their numbered sequence, unless the auctioneer announces otherwise at the Auction.
- 4.3.5. The auctioneer may accept bids from Bidders present in the sale room, via telephone, or via online at the time of the Auction. The auctioneer may also accept proxy or absentee bids delivered to Propstore before the start of the Auction. Proxy or absentee bids must be submitted either by using the form in the Buyer’s Guide or the online form at [www.propstore.com](http://www.propstore.com). Proxy or absentee bids will be executed at the lowest possible price. If Propstore receives proxy or absentee bids on a particular Lot for identical maximum bids, and at the Auction these are the highest bids on the Lot, it will be sold to the Bidder whose written bid was first received by Propstore.
- 4.3.6. Any Bidder wishing to place bids at the time of the Auction via telephone must provide to Propstore a list of Lots on which they intend to bid at least 24 hours before the start of the Auction.
- 4.3.7. In addition to Propstore’s Conditions, any Bidder placing bids online must comply with the terms for use of the online auction platform access provider.
- 4.3.8. Except as expressly stated in the Buyer’s Guide or the Conditions, Propstore shall have no liability arising out of or related to any errors or omission in respect of bids made online, by telephone or by proxy.
- 4.3.9. The Auction will be tracked on a video or digital screen, which may display, among other things, a photograph of the Lot offered for sale and the then-current bid. Bidders understand and agree that errors may occur in its operation and, except as expressly stated in the Buyer’s Guide or these Conditions, Propstore shall have no liability arising out of or related to any errors or omission in respect thereto.

#### 4.4. Auctioneer’s Authority

- 4.4.1. The auctioneer has the right to exercise reasonable discretion in refusing any bid, advancing the bidding in such a manner as he or she may decide, dividing any Lot, combining any two or more Lots and, in the case of error or dispute, and whether during or after the sale, determining the successful Buyer, continuing the bidding, cancelling the sale or reoffering and reselling the Lot in dispute. If any dispute arises after the sale, then, in the absence of any evidence to the contrary the sale record maintained by the auctioneer will be conclusive.
- 4.4.2. The auctioneer shall have sole discretion to accept or decline any bid.
- 4.4.3. Subject to the auctioneer’s reasonable discretion, the Bidder placing the highest bid accepted by the auctioneer will be the Buyer and the striking of his hammer marks the acceptance of the highest bid and the conclusion of a contract for sale between the Seller and the Buyer. Each Bidder understands and agrees that Propstore, as auctioneer, is not a party to any contract for sale that results from the Auction. Risk and responsibility for the Lot (including frames or glass where relevant) passes to the Buyer upon the fall of the hammer and the Buyer should arrange insurance cover for the Lot if required.

## Terms & Conditions

### 5. After the Auction

#### 5.1. Payment by Buyer

5.1.1. Propstore will notify the Buyer and send (by email unless requested otherwise) a payment invoice setting out the Purchase Price and itemizing the Hammer Price, the Buyer's Premium, plus any applicable Buyer's Expenses, applicable Credit Card Fee, or sales tax, within 7 business days of the end of the Auction. Sales tax, as required by law, shall be applied at the state's prevailing rate where Propstore is obligated to charge sales tax. Please see the Sales Tax Quick Reference Guide at the end of these Terms and Conditions for additional information.

5.1.2. Unless you have been approved for a payment plan as set forth in Paragraph 5.1(c) of the Terms and Conditions of Sale, payment of the invoice is due within 7 business days from receipt of the invoice and must be made by the Buyer

5.1.3. Payment plans may be available in increments of up to three (3) months for purchases where total Hammer Price and Buyer's Premium are greater than \$1,000. Purchases where total Hammer Price and Buyer's Premium are less than \$1,000 are not eligible for a payment plan; buyers paying via Cryptocurrency are also not eligible for a payment plan. Payment plan may not be available for all Lots; Lots where payment plan is not applicable will be identified in their description. Buyers wishing to utilize the payment plan service, if approved by Propstore, shall be required to pay a deposit of 20% of the Purchase Price (the "Deposit"), within 7 calendar days of being invoiced. The balance of the Purchase Price shall then be split over 1, 2 or 3 months, at the Buyer's option. The payments of the remaining balance shall be made as follows:

5.1.3.1. If the 1-month payment plan is selected, the balance of the Purchase Price shall be due within 30 days of the close of the Auction.

5.1.3.2. If the 2-month payment plan is selected: 40% of the Purchase Price shall be due within 30 days of the close of the Auction; 40% of the balance of the Purchase Price shall be due within 60 days of the close of the Auction.

5.1.3.3. If the 3-month payment plan is selected: 26.66% of the Purchase Price shall be due within 30 days of the close of the Auction; 26.66% of the balance of the Purchase Price shall be due within 60 days of the close of the Auction; and 26.68% due within 90 days of the close of the Auction.

5.1.4. Propstore offers no grace period on payment plan deadlines. If the Buyer does not adhere to payment deadline as set forth above, the Buyer shall be deemed to be in default. In the event of default all funds already paid to Propstore shall be retained by Propstore as liquidated damages. Moreover, Propstore and/ or the Seller shall also be entitled to any other remedies available, whether in law or equity.

5.1.5. No title to any Property shall pass to the Buyer except upon payment in full of the Purchase Price, and any and all other sums due to Propstore and/or the Seller, even in circumstances where Propstore has released the Lot to the Buyer. Among other remedies available to Propstore and the Seller for failure to render full payment of the Purchase Price, Propstore and/or the Seller shall be entitled to immediate possession of the Lot purchased by the Buyer, if delivered to the Buyer.

5.1.6. Propstore vouchers and other discount codes are not valid as payment for auction items.

5.1.7. Only the memorabilia item(s) shown in the photos of a given product listing is included in the sale. Mannequins, display stands, and scale measures are not included with your purchase, unless expressly stated in the product description.

5.1.8. The Buyer agrees that Propstore will charge the credit card provided at registration for all items purchased at auction, and any future Propstore auctions in which the Buyer participates if not paid within 7 calendar days after invoicing.

5.1.9. The Buyer shall be charged in US Dollars for the Purchase Price.

5.1.10. Payment must be in US dollars and may be made by electronic transfer, debit card, credit card (up to a maximum of \$25,000), bankers draft or check (drawn on a US bank account – note check clearance can take between 5 and 10 working days), or cash (up to a maximum of \$5,000). Please quote the Lot number, invoice number and Bidder registration number when making payment to ensure it can be processed as efficiently as possible.

5.1.11. If payment is made by credit card, the Buyer expressly agrees that such payment is nonrefundable nor may be credited to any other purchase, and that the Buyer will not undertake any action or effort to stop payment, seek a refund, or attempt a charge back of such amounts by the issuer of the credit card.

5.1.12. Cryptocurrency payments are accepted via our payment processor (Bitpay), as indicated at checkout. You must pay for the entire balance owed including the Purchase Price and any other relevant charges entirely in one form of Cryptocurrency and you should ensure you have a sufficient balance to pay for all sums owed. We do not accept partial payment by Cryptocurrency and a different form of payment in one transaction. Cryptocurrency payment is only acceptable on the express understanding that the Lot is not returnable, refundable nor exchangeable. Buyers paying with Cryptocurrency are also not eligible to use payment plans. We reserve the right to exclude the use of payment by Cryptocurrency on certain Lots, such exclusion to be noted on the listing.

#### 5.2. Default by Buyer

5.2.1. Failure to timely make payment of any amounts due to Propstore and/or the Seller shall constitute an event of Default by the Buyer. In the event of Default for nonpayment, Propstore may charge interest on the unpaid amount at the rate of 5% a year above the base lending rate of Bank of America from time to time. The base lending rate shall be the average lending rate of Bank of America for the 6 months preceding the date of default. If such interest rate exceeds the legal rate permitted by law, then the maximum legal rate permitted by law shall apply. This interest shall accrue on a daily basis from the due date until the date of actual payment of the overdue amount. The Buyer must pay Propstore interest together with any overdue amount.

5.2.2. If any applicable conditions herein are not complied with (to a material extent), the Buyer will be in Default and in addition to any and all other remedies available to Propstore by law, including, without limitation, the right to hold the Buyer liable for the total Purchase Price, including all fees, charges and expenses more fully set forth herein, and as set forth in paragraph 4.2(a) herein, Propstore, at its option and to the extent permitted by law, may (i) cancel the sale of that, or any other items sold to the defaulting Buyer, retaining as liquidated damages all payments made by the Buyer, (ii) resell the purchased item, or (iii) effect any combination thereof. In any case, the Buyer shall be liable for any deficiency, any and all costs, handling charges, late charges, expenses of both sales, legal fees and expenses, collection fees and incidental damages.

5.2.3. Propstore may, in its sole discretion, apply any proceeds of sale then due or thereafter becoming due to the Buyer from Propstore or any affiliated company, or any payment made by the Buyer to Propstore or any affiliated company, where or not intended to reduce the Buyer's obligations with respect to the unpaid item or items, to the deficiency and any other amounts due to Propstore or any affiliated companies. In addition, a defaulting Buyer will be deemed to have granted and assigned to Propstore and its affiliated companies, a continuing security interest of first priority in any property or money owing to such Buyer in our possession or in the possession of any of its affiliated companies, and Propstore may retain and apply such property or money as collateral security for the obligations due to Propstore or to any affiliated company. Payment will not be deemed to have been made in full until Propstore has collected good funds.

5.2.4. Propstore may further reject at any future auction any bids made by or on behalf of the Buyer or to require a deposit from the Buyer before accepting any further bids;

5.2.5. Propstore may take such other action as Propstore deems necessary or appropriate.

5.2.6. At its option, Propstore may pay the Seller the entirety of the balance due from the Buyer. If Propstore pays such amount to the Seller, the Buyer acknowledges and agrees that Propstore shall have all of the rights of the Seller against the Buyer.

## Terms & Conditions

5.2.7. Propstore shall be entitled to retain Lots sold until all amounts due have been received in full in good cleared funds or until the Buyer has performed any other outstanding obligations as Propstore shall reasonably require.

5.2.8. Propstore shall be entitled to release the name and address of the Buyer to the Seller to enable the Seller to commence legal proceedings to recover the amounts due and legal costs. Prop Store will take reasonable steps to notify the Buyer prior to releasing such details to the Seller.

#### 5.3. Shipping and Storage

5.3.1. The Buyer is solely responsible for all shipping, handling, and delivery costs. Propstore can help you arrange packing and shipping through FedEx or USPS for smaller items or PackAir AirFreight, Inc. for larger items, or you can use your own licensed carrier, approved by Propstore. Please contact Propstore at +1 818 727 7829 for further details. Propstore does not warranty the Lots against and shall have no liability for any damage that any Lot may incur or suffer during the shipping or delivery process. Propstore offers insurance for shipments in transit at an additional charge; buyers will have an option to select this when finalizing your purchase after auction.

5.3.2. After 30 days after close of Auction, if Buyer has not made arrangements for and paid the shipping cost of the Lots purchased, or has otherwise failed to collect the Lots, Propstore may impose a storage fee of 3% of the Hammer Price per month to be charged to the Buyer.

5.3.3. It is the Buyer's sole obligation and responsibility to be aware of, to comply with, and to pay for all relevant import duties, taxes, VAT, customs and other fees charged in the area of delivery. Propstore will ship all packages with the full value of the Lot declared. The Buyer understands and agrees that Propstore shall have no obligation or responsibility for any import duties, taxes, VAT, customs, shipping or other charges for the Lots shipped. Failure by the Buyer to pay all necessary amounts may result in the relevant authorities returning the Lot to Propstore and in those circumstances the Buyer will be charged and will pay storage cost and Propstore's additional reasonable costs and expenses.

5.3.4. It is further the Buyer's sole obligation and responsibility to ensure that any Lot purchased from Propstore enters the shipping location lawfully, that all duties and taxes have been paid and that all required export procedures, regulations, and laws were properly complied with. The Buyer understands and agrees that Propstore shall have no obligation or responsibility for complying with any export procedures, regulations, or laws applicable to the Lot.

5.3.5. Unless otherwise agreed by Propstore in writing, the fact that the Buyer wishes to apply for an export license does not affect or postpone the Buyer's obligation to make payment in accordance with Propstore's payment terms nor Propstore's right to charge interest or storage charges on late payment. Propstore shall not be obligated to rescind or cancel a sale nor to refund any monies paid by the Buyer to Propstore as a result of or related to the Buyer's failure or inability to obtain an export license.

5.3.6. Should the Buyer make own arrangements with third parties for shipping, handling, or delivery of any Lots, Propstore shall have and accepts no liability or responsibility for the acts or omissions of any such third parties. Similarly, where Propstore suggests other handlers, packers or carriers, its suggestions are made on the basis of its general experience of such parties in the past. Although Propstore shall use reasonable efforts to take care when selecting third parties for shipping and delivery, and the Buyer understands and agrees that Propstore is not responsible to any person to whom it has made a recommendation for the acts or omissions of the third party concerned.

#### 5.4. Propstore's Liability

5.4.1. Except where expressly stated to the contrary above, under no circumstance will Propstore incur liability to any Bidder or Buyer in excess of the purchase price actually paid.

5.4.2. Propstore will not be liable or responsible for any failure to perform, or delay in performance of, any of its obligations under these Conditions that is caused by an event outside its control, that being any act or event beyond Propstore's reasonable control, including without limitation strikes, lockouts or other industrial action by third parties, civil commotion, riot, invasion, terrorist attack or threat of terrorist attack, war (whether declared or not) or threat or preparation for war, fire, explosion, storm, flood, earthquake, subsidence, epidemic or other natural disaster, or failure of public or private telecommunications networks. Propstore's obligations shall be suspended and time for performance extended until such time as the event outside its control is over, following which a new collection or shipping date can be agreed.

### 6. Terms of Guarantee

6.1. Propstore warrants the attribution of each Lot as stated in the title block (film title and item title) of that Lot in the Auction catalog, subject to any revisions (which may be given in writing or online before or during the Auction at which the Lot is purchased by the Buyer); this is Propstore's Guarantee of Attribution. Buyers should be aware that multiple examples of props and costumes are frequently used during production and it is often impossible to determine whether a specific piece has been used on-camera. Any specific on-camera usage known to Propstore will be noted within the description, but no warranties are given by Propstore on that description.

6.2. If a Buyer demonstrates, to Propstore's reasonable satisfaction, that the Guarantee of Attribution is materially incorrect, the sale will be rescinded if the Lot is returned to Propstore in the same condition in which it was at the time of sale. In order to satisfy Propstore that the Guarantee of Attribution is materially incorrect, Propstore reserves the right to require the Buyer to obtain, at the Buyer's expense, the opinion of two experts in the field, mutually acceptable to Propstore and the Buyer.

6.3. In the event a sale is rescinded in accordance with condition 10.2, Propstore shall repay to the Buyer the Purchase Price. Repayment of the Purchase Price shall be the Buyer's sole remedy for an incorrect Guarantee of Attribution, to the exclusion of all other remedies to the extent permissible at law. It is specifically understood that this will be considered the Buyer's sole remedy under this clause 10.

6.4. The Buyer expressly agrees that Propstore shall not be liable in whole or in part, for, and the Buyer shall not be entitled to recover, any special, indirect, incidental or consequential damages including loss of profits or value of investment or opportunity cost.

6.5. Bidders are aware that description revisions may occur on some Lots, and should inquire before the Auction whether any description revisions have occurred on a given Lot and/or examine a lot before bidding on it. Propstore will make all reasonable efforts to make description revisions readily available during the Auction.

### 7. Warranties and Representations

7.1. The copyright in all images, illustrations and written material produced by or for Propstore relating to this auction, is and shall remain at all times the property of Propstore and/or the Consignor. The purchase of these items does not include ownership in or to the trademarks registrations, copyrights and/or any other intangible intellectual properties associated with this item. Therefore purchase of this item does not permit the Buyer to replicate or to exploit this item otherwise. The Buyer agrees to indemnify and hold harmless Propstore and its directors, employees, affiliates, contractors and agents from any third-party claims, actions, suits, judgments, losses, damages, costs and expenses (including reasonable attorneys' fees) asserted against or incurred by Propstore that arise out of or result from any act or omission by the Buyer arising out of or relating to the Buyer's infringement of any copyrights or trademarks in or to the items or images.

7.2. Propstore neither warrants nor represents that the Buyer's use of any materials displayed on the site will not infringe rights of third parties not owned by or affiliated with Propstore.

7.3. In the catalog descriptions, Propstore takes steps to identify and provide provenance for Lots offered at Auction. In many cases, the Lots offered were used in or in conjunction with motion pictures or other programs and information is furnished in order to fully identify and describe the Lot offered at Auction, including photographs and illustrations. Propstore in no way claims any connection to or relationship with the producers of the motion picture or other program. In all cases, the use of the titles or other elements of a motion picture or other program is for informational purposes only.

7.4. Propstore makes no warranty or representation regarding the fitness for any purpose or merchantability of any lot sold. All lots are sold "as is."

## Terms & Conditions

75. Bidders are aware that description revisions may occur on some Lots, and should inquire before the Auction whether any description revisions have occurred on a given Lot and/or examine a lot before bidding on it. Propstore will make all reasonable efforts to make description revisions readily available during the Auction. While Propstore uses reasonable efforts to include accurate and up to date information in this auction, Propstore makes no warranties or representations as to its accuracy. Propstore assumes no liability or responsibility for any errors or omissions in the content of the auction. Any reference images appearing within Propstore's auction listings are solely for reference purposes and are not intended or deemed to be a representation or warranty of the item depicted within the image.
76. All items are sold as collectibles and/or memorabilia for display purposes only, and are not deemed, intended, represented, or implied to be fit for any other purpose. The Buyer assumes all risks of loss and/or injury, including, but not limited to, personal injury or property damage, arising from or related to any other use of the item. The Buyer understands and agrees that Propstore shall have no liability for any such loss or injury and the Buyer expressly releases Propstore from any such loss or injury.
77. Except as expressly provided herein, Propstore shall have no liability to any Bidder or Buyer with respect to any Lot and all and any implied warranties and conditions are excluded to the fullest extent permitted by law.
78. Each Bidder and Buyer expressly agrees that Propstore shall not be liable in whole or in part, for, and no Bidder or Buyer shall be entitled to recover, any special, indirect, incidental or consequential damages including loss of profits or value of investment or opportunity cost, for any breach of any warranty, representation, or guarantee set forth herein.

## 8. Other Important Terms

- 8.1. If any part of these Conditions is found by any arbitrator or court of competent jurisdiction to be invalid, illegal or unenforceable, that part shall be discounted and the rest of the Conditions shall continue to be valid to the fullest extent permitted by law.
- 8.2. The contract is between the Seller, the Buyer and Propstore and no other person shall have any rights to enforce any of its terms.
- 8.3. If Propstore fails to insist on performance of any of a Buyer's obligations under these Conditions, or if it delays in doing so, that will not mean that Propstore has waived its rights against the Buyer and does not mean the Buyer no longer has to comply with those obligations.
- 8.4. These Conditions shall be enforced in accordance with and governed by the laws of the State of California, without regard to its choice of law provisions.
- 8.5. Any claim or controversy arising out of or relating to the sale of the item between any Bidder/Buyer and Propstore shall be submitted to arbitration in Los Angeles County, California before an arbitrator from the Judicial Arbitration and Mediation Services, Inc. ("JAMS") and conducted under its Comprehensive Arbitration Rules, as the exclusive remedy for such claim or controversy. The parties further agree that the arbitration shall be conducted before a single JAMS arbitrator who is a retired California or federal judge or justice. By agreeing to arbitrate, the parties waive any right they have to a court or jury trial. The decision of the arbitrator shall be final and binding. The parties further agree that, upon application of the prevailing party, any Judge of the Superior Court of the State of California, for the County of Los Angeles, may enter a judgment based on the final arbitration award issued by the JAMS arbitrator, and the parties expressly agree to submit to the jurisdiction of this Court for such a purpose. The prevailing party shall be entitled to recover the party's attorneys' fees and costs incurred in connection with the arbitration.

## Sales Tax Quick Reference Guide

Arizona	California	Colorado	Florida	Georgia	Illinois	Indiana	Kansas	Louisiana	Maryland	Massachusetts	Michigan
Minnesota	New Jersey	New York	North Carolina	Ohio	Pennsylvania	Texas	Utah	Vermont	Virginia	Washington	Wisconsin

If you are shipping goods to any of these states, state and local sales tax will be calculated and added to your order based on your address. Propstore charges sales tax in accordance with the individual state requirements; therefore additional states may become taxable for purchases from Propstore at any time. Buyers are encouraged to check with Propstore prior to bidding if they have questions about the sales tax status of potential purchases.

## Special Notices

### Notice on Lots Requiring Special Shipping

Lots with this disclaimer, due to their size and/or nature (including lots which may be shipped from offsite) will require specialist shipping service with additional cost. Buyer will be responsible for all shipping costs of Lots. Bidders are strongly advised to contact Propstore for a shipping quote prior to bidding on these Lots.

### Notice on Off-site Storage

Some lots in the auction are stored off-site, outside of Propstore's primary facility. They may be stored in another State and therefore will ship from their current location to Buyer's location, at Buyer's expense. These lots will not be available to preview before the auction without special arrangements. Buyer will be responsible for all shipping costs of Lots, regardless of Lot storage location. Please contact Propstore for a shipping quote prior to bidding on off-site storage lots.

### U.K. Storage

Certain Lots are currently located in Propstore's London facility and will ship directly to the buyer from the London facility. Any such Lots will be identified in the catalog with the symbol U.K. next to its lot number. Buyer will be responsible for all shipping and import charges from the U.K. See clause 5.3.3 of Terms & Conditions and please inquire for additional information.

### Propstore Interest Δ

From time to time, Propstore may offer a Lot which it owns in whole or in part or in which it has a financial interest and any such Lot will be identified in the catalog with the symbol Δ next to its Lot number.

### Notice on Electronics and Mechanics

Some lots in the auction contain electronic and/or mechanical components. While every effort is made to describe them accurately, no guarantee or warranty is made as to the functionality, lifespan or safety of those components. It is entirely incumbent on the new owner to satisfy themselves as to their safe use and maintenance.

### Notice on Copyright

Lots with this disclaimer are sold without copyright, reproduction rights, licencing agreements or any other type of legal release.

### Notice on Firearm Deactivation

Firearms with this disclaimer have been permanently and sympathetically deactivated to U.K. legal requirements and no longer retains any functional capacity to fire; a U.K. proof house certificate of deactivation is included. It is solely the buyer's responsibility to check, prior to bidding, the legal status of this weapon within their own country and the importation therein. All costs associated with the transfer will be the buyer's responsibility.

### Notice on Replica Firearms and UK Restrictions

Replica firearms Lots will ship with a blaze orange plug affixed to their barrel tip (plug is not depicted in catalog illustrations.) Buyers should be aware that ownership of Lots with this disclaimer is restricted for UK residents to registered re-enactors, galleries, or individuals in film, television, or theater production. Please inquire for further details. There may be restrictions applicable to Buyers in other countries as well; it is solely the Buyer's responsibility to check, prior to bidding, the legal status of this item within their own country and the importation therein.

# Every year we do something impossible

Experience our largest exhibition celebrating 75 years of Porsche



# WE ARE PORSCHE

40 Vehicles, 75 Years of Amazing Stories

**PETERSEN**  
AUTOMOTIVE MUSEUM  
6060 Wilshire Blvd, Los Angeles CA 90036  
A 501(c)(3) nonprofit organization



April 2023 — April 2024  
**petersen.org/porsche-75**

Supported by Porsche Cars North America and Scan Global Logistics Additional support provided by Michelin

**DAY 01**

**LOTS 1 – 523**  
 PG. 6 – 411  
 JUNE 28, 2023  
 WEDS. 8:00 AM (PDT)  
 4:00 PM (BST)

**DAY 02**

**LOTS 524 – 1014**  
 PG. 412 – 555  
 JUNE 29, 2023  
 THUR. 8:00 AM (PDT)  
 4:00 PM (BST)

**DAY 03**

**LOTS 1015 – 1487**  
 PG. 556 – 697  
 JUNE 30, 2023  
 FRI. 8:00 AM (PDT)  
 4:00 PM (BST)

**DAY 01**

**LOTS 1 – 523**  
 PG. 6 – 411  
 JUNE 28, 2023  
 WEDS. 8:00 AM (PDT)  
 4:00 PM (BST)

**DAY 02**

**LOTS 524 – 1014**  
 PG. 412 – 555  
 JUNE 29, 2023  
 THUR. 8:00 AM (PDT)  
 4:00 PM (BST)

**DAY 03**

**LOTS 1015 – 1487**  
 PG. 556 – 697  
 JUNE 30, 2023  
 FRI. 8:00 AM (PDT)  
 4:00 PM (BST)

**Index**

Film or Show	Page Number(s)	Film or Show	Page Number(s)
<b>#</b>		BETTER CALL SAUL (2015-2022) .....	45 – 46, 435 – 437
102 DALMATIANS (2000) .....	413	BETTY WHITE .....	510
1984 SUMMER OLYMPICS .....	338, 661	BEVERLY HILLS COP (1984) .....	47, 437
20,000 LEAGUES UNDER THE SEA (1954) .....	413	BEVERLY HILLS COP II (1987) .....	47
2001: A SPACE ODYSSEY (1968) .....	413 – 414	BICENTENNIAL MAN (1999) .....	48 – 49
2010: THE YEAR WE MAKE CONTACT (1984) .....	7	BIG BANG THEORY, THE (2007-2019) .....	437
3-10 TO YUMA (2007) .....	8	BIG LEBOWSKI, THE (1998) .....	50 – 57, 438 – 441
300 (2006) .....	9	BILL & TED'S BOGUS JOURNEY (1991) .....	441
48 HRS. (1982) .....	414	BLACK ADAM (2022) .....	441
		BLADE (1998) .....	58 – 59
		BLADE RUNNER (1982) .....	60 – 65, 442 – 443
		BLADE RUNNER 2049 (2017) .....	443
<b>A</b>		BLADE: TRINITY (2004) .....	57, 444
A FAR OFF PLACE (1993) .....	414	BLADES OF GLORY (2007) .....	444
ABYSS, THE (1989) .....	10 – 12	BLOB, THE (1988) .....	444
ACADEMY AWARDS .....	585	BOOGIE NIGHTS (1997) .....	68, 445 – 446
ACE VENTURA: PET DETECTIVE (1994) .....	414	BOSS FILMS VFX COMPANY .....	66 – 67
ADDAMS FAMILY, THE (1991) .....	13	BOY WHO COULD FLY, THE (1986) .....	446
ADVENTURES OF PLUTO NASH, THE (2002) .....	415	BRAM STOKER'S DRACULA (1992) .....	69, 446 – 447
AEON FLUX (2005) .....	415	BRAVEHEART (1995) .....	70 – 75, 447 – 450
AIRWOLF (1984-1987) .....	415	BREAKING BAD (2008-2013) .....	76 – 77, 450 – 452
ALFRED HITCHCOCK PRESENTS (1955-1965) .....	12	BRING IT ON (2000) .....	452
ALICE IN WONDERLAND (2010) .....	416	BROTHERLY LOVE (1995-1997) .....	510
ALIEN (1979) .....	13 – 15, 416 – 417	BRUCE LEE .....	78 – 80, 453
ALIEN RESURRECTION (1997) .....	18 – 19, 419 – 420	BUCKET LIST, THE (2007) .....	453
ALIEN WAR (ATTRACTION, 1992) .....	421	BUGGY THE VAMPIRE SLAYER (1997-2003) .....	81
ALIEN3 (1992) .....	419	BUGSY (1991) .....	453
ALIENS (1986) .....	16 – 17, 418	BULLET TRAIN (2022) .....	454 – 455
ALTERED CARBON (2018-2020) .....	421	'BURBS, THE (1989) .....	455
ALTERED STATES (1980) .....	421	BUTCH CASSIDY AND THE SUNDANCE KID (1969) .....	456
AMISTAD (1997) .....	422		
ANY GIVEN SUNDAY (1999) .....	422	<b>C</b>	
APOCALYPTO (2006) .....	422 – 423	CABIN BOY (1994) .....	456
APOLLO 13 (1995) .....	24	CANDYMAN: FAREWELL TO THE FLESH (1995) .....	456
AQUAMAN (2018) .....	24	CAPTAIN AMERICA (1990) .....	82
ARMAGEDDON (1998) .....	423	CAPTAIN AMERICA: THE FIRST AVENGER (2011) .....	546
ARMY OF DARKNESS (1992) .....	424	CARAVAN OF COURAGE: AN EWOK ADVENTURE (1984) .....	338 – 340, 660
ARROW (2012-2020) .....	424	CAROL BURNETT SHOW: A REUNION, THE (1993) .....	456
ASH VS EVIL DEAD (2015-2018) .....	424	CASINO (1995) .....	457
AUSTIN POWERS: INTERNATIONAL MAN OF MYSTERY (1997)/AUSTIN POWERS: THE SPY WHO SHAGGED ME (1999) .....	425	CAST AWAY (2000) .....	82, 457
AUTOMAN (1983-1984) .....	425	CATCH ME IF YOU CAN (2002) .....	84, 458
AVATAR (2009) .....	425	CHAPLIN (1992) .....	459
AVP: ALIEN VS. PREDATOR (2004) .....	22 – 23, 420	CHARLIE AND THE CHOCOLATE FACTORY (2005) .....	459
AVPR: ALIENS VS. PREDATOR-REQUIEM (2007) .....	20 – 21	CHARLOTTE'S WEB (2006) .....	459
		CHERRY 2000 (1987) .....	460
		CHILD'S PLAY 2 (1990) .....	460
		CHRISTINE (1983) .....	84
<b>B</b>		CHRONICLES OF NARNIA, THE: PRINCE CASPIAN (2008) .....	461
BACK TO THE FUTURE (1985) .....	25	CHRONICLES OF NARNIA, THE: THE LION, THE WITCH AND THE WARDROBE (2005) .....	461
BACK TO THE FUTURE PART II (1989) .....	25 – 29, 426 – 428	CHRONICLES OF RIDDIK, THE (2004) .....	462
BACK TO THE FUTURE PART III (1990) .....	428	CLASH OF THE TITANS (2010) .....	85
BACK TO THE FUTURE TRILOGY (1985-1990) .....	30	CLIFFHANGER (1993) .....	462
BASIC INSTINCT (1992) .....	429	CLOSE ENCOUNTERS OF THE THIRD KIND (1977) .....	463 – 464
BATMAN & ROBIN (1997) .....	432	CN TOWER .....	464
BATMAN (1989) .....	34 – 37, 429	CONAN THE BARBARIAN (1982) .....	85, 465
BATMAN FOREVER (1995) .....	43 – 44, 432	CONQUEST OF THE PLANET OF THE APES (1972) .....	585
BATMAN FOREVER (1995)/BATMAN & ROBIN (1997) .....	432	CREED (2015) .....	465
BATMAN RETURNS (1992) .....	37 – 43, 429 – 431	CREEPSHOW (1982) .....	466 – 467
BATMAN: THE ANIMATED SERIES (1992-1995) .....	432	CREEPSHOW (2019-PRESENT) .....	468
BATTLESTAR GALACTICA (1978) .....	44, 433	CREEPSHOW 2 (1986) .....	467 – 468
BATTLESTAR GALACTICA (2003) .....	44	CRIMSON TIDE (1995) .....	469
BEAVIS AND BUTT-HEAD (1993-2011) .....	433 – 434	CRITTERS (1986) .....	86
BEEZLEJUICE (1988) .....	434	CRITTERS 4 (1992) .....	86
BEING JOHN MALKOVICH (1999) .....	435	CROW, THE (1994) .....	87
BENEATH THE PLANET OF THE APES (1970) .....	579		
BEST LITTLE WHOREHOUSE IN TEXAS, THE (1982) .....	509		

**Index**

Film or Show	Page Number(s)	Film or Show	Page Number(s)
CULT OF CHUCKY (2017) .....	83	FREDDY VS. JASON (2003) .....	120 – 121, 488 – 489
		FREDDY'S DEAD: THE FINAL NIGHTMARE (1991) .....	237 – 238
<b>D</b>		FRENCH LINE, THE (1953) .....	485
DARK CRYSTAL, THE (1982) .....	92, 469 – 471	FRIDAY THE 13TH (2009) .....	122 – 124, 489 – 490
DARK HORSE COMICS .....	344, 661	FRIDAY THE 13TH PART VI: JASON LIVES (1986) .....	113, 485
DARK KNIGHT, THE (2008)/DARK KNIGHT RISES, THE (2012) .....	88	FRIDAY THE 13TH PART VII: THE NEW BLOOD (1988) .....	114 – 116, 118, 485 – 486
DARK KNIGHT, THE (2008) .....	472	FRIDAY THE 13TH PART VIII: JASON TAKES MANHATTAN (1989) .....	117, 486 – 487
DC COMICS (1934) .....	473	FROM DUSK TILL DAWN (1996) .....	490
DEBBIE REYNOLDS .....	510	FUGITIVE, THE (1993) .....	491
DEEP BLUE SEA (1999) .....	473	FULL METAL JACKET (1987) .....	491
DEXTER (2006-2013) .....	473 – 474	FURY (2014) .....	124 – 125
DICK TRACY (1990) .....	474		
DICK TRACY SERIES PILOT (1967) .....	474	<b>G</b>	
DIE HARD (1988) .....	87, 474 – 475	G.I. JOE: THE RISE OF COBRA (2009) .....	491 – 493
DIE HARD 2 (1990) .....	475	GALACTICA 1980 (1980) .....	433
DIE HARD WITH A VENGEANCE (1995) .....	93	GALAXY QUEST (1999) .....	126, 493
DISNEY STUDIOS .....	93	GAME OF THRONES (2011-2019) .....	125
DISNEYLAND PARK .....	94 – 95, 97 – 98	GAME, THE (1997) .....	494
DOCTOR STRANGE (2016) .....	546	GENERAL'S DAUGHTER, THE (1999) .....	494
DOCTOR WHO (2005) .....	99	GHOST IN THE SHELL (2017) .....	126
DOLLY PARTON .....	510	GHOSTBUSTERS (1984) .....	127 – 133, 495 – 497
DOMINO'S PIZZA COMMERCIALS .....	475	GHOSTBUSTERS (2016) .....	134 – 141, 498 – 501
DONNIE DARKO (2001) .....	475	GHOSTBUSTERS II (1989) .....	497 – 498
DOOM (2005) .....	476	GLADIATOR (2000) .....	141 – 144, 501
DRAGON: THE BRUCE LEE STORY (1993) .....	476	GODFATHER PART II, THE (1974) .....	148, 501
DREAMGIRLS (2006) .....	476	GODFATHER, THE (1972) .....	502
DUKES OF HAZZARD, THE (1979-1985) .....	100	GOLDEN GIRLS, THE (1985-1992) .....	146 – 147, 502 – 512
DUNE (2000) .....	477	GOLDEN PALACE, THE (1992-1993) .....	514
		GOONIES, THE (1985) .....	145, 515
		GOONIES, THE (1985)/HOOK (1991) .....	515
<b>E</b>		GORILLAS IN THE MIST (1988) .....	148
ET. THE EXTRA-TERRESTRIAL (1982) .....	100, 477 – 478	GRAND BUDAPEST HOTEL, THE (2014) .....	515
EDGE OF TOMORROW (2014) .....	101	GREEN HORNET, THE (1966-1967) .....	80
EDWARD SCISSORHANDS (1990) .....	102 – 103	GREEN MILE, THE (1999) .....	149, 516
ELF (2003) .....	104 – 105	GREMLINS (1984) .....	150 – 151
ELVIRA: MISTRESS OF THE DARK (1988) .....	478	GREMLINS 2: THE NEW BATCH (1990) .....	152 – 155, 516
ELVIS (2022) .....	478	GREYSTOKE: THE LEGEND OF TARZAN, LORD OF THE APES (1984) .....	518
EMPTY NEST (1988-1995) .....	511	GRIMM (2011-2017) .....	155
END OF DAYS (1999) .....	479	GUARDIANS OF THE GALAXY (2014) .....	216 – 217
ENDLESS LOVE (1981) .....	479		
ER (1994-2009) .....	480		
ESCAPE FROM L.A. (1996) .....	105, 480	<b>H</b>	
ESTELLE GETTY .....	512 – 513	H.R. GIGER .....	417
EVIL DEAD II (1987) .....	105	HALLOWEEN H20: 20 YEARS LATER (1998) .....	156 – 158
EXISTENZ (1999) .....	480	HALLOWEEN II (2009) .....	517
EXODUS: GODS AND KINGS (2014) .....	106	HARRY AND THE HENDERSONS (1987) .....	159
EXPENDABLES 2, THE (2012) .....	106	HARRY POTTER AND THE CHAMBER OF SECRETS (2002) .....	160 – 162
EXPENDABLES 3, THE (2014) .....	107 – 108	HARRY POTTER AND THE PHILOSOPHER'S STONE (2001) .....	163 – 166
EXPENDABLES, THE (2010) .....	481	HARRY POTTER AND THE PRISONER OF AZKABAN (2004) .....	519
		HARRY POTTER AND THE SORCERER'S STONE (2001) .....	518
		HARRY POTTER FRANCHISE (1997-2007) .....	519
<b>F</b>		HATCHET (2006) / HATCHET III (2013) .....	167
FABULOUS BAKER BOYS, THE (1989) .....	481	HATEFUL EIGHT, THE (2015) .....	168
FACE/OFF (1997) .....	481	HELLBOY (2004) .....	520
FANTASTIC MR. FOX (2009) .....	108	HELLRAISER (1987) .....	520
FAR AND AWAY (1992) .....	481	HELLRAISER (2022) .....	520
FERRIS BUELLER'S DAY OFF (1986) .....	109	HELLRAISER III: HELL ON EARTH (1992) .....	169
FIELD OF DREAMS (1989) .....	110 – 111	HELLRAISER: BLOODLINE (1996) .....	169
FIFTH ELEMENT, THE (1997) .....	482	HERCULES: THE LEGENDARY JOURNEYS (1995-1999) .....	521
FIGHT CLUB (1999) .....	112, 482 – 483	HITCHHIKER'S GUIDE TO THE GALAXY, THE (1981-1981) .....	521
FINDING NEVERLAND (2004) .....	483	HOBBIT, THE: AN UNEXPECTED JOURNEY (2012) .....	213
FIRST KNIGHT (1995) .....	112	HOCUS POCUS (1993) .....	521
FLUBBER (1997) .....	112	HOLIDAY, THE (2006) .....	522
FORREST GUMP (1994) .....	484	HOME ALONE 2: LOST IN NEW YORK (1992) .....	522
FRANK HERBERT'S CHILDREN OF DUNE (2003) .....	477	HOOK (1991) .....	167, 522 – 524

**DAY 01**

**LOTS 1 – 523**  
 PG. 6 – 411  
 JUNE 28, 2023  
 WEDS. 8:00 AM (PDT)  
 4:00 PM (BST)

**DAY 02**

**LOTS 524 – 1014**  
 PG. 412 – 555  
 JUNE 29, 2023  
 THUR. 8:00 AM (PDT)  
 4:00 PM (BST)

**DAY 03**

**LOTS 1015 – 1487**  
 PG. 556 – 697  
 JUNE 30, 2023  
 FRI. 8:00 AM (PDT)  
 4:00 PM (BST)

**Index**

Film or Show	Page Number(s)
HOT IN CLEVELAND (2010-2015)	524
HOUSE (2004-2012)	524
HOUSE OF 1000 CORPSES (2003)	525
HOUSE OF WAX (2005)	525
HOW THE GRINCH STOLE CHRISTMAS (2000)	525
HUGO (2011)	170
<b>I</b>	
I, ROBOT (2004)	170, 525
IDLE HANDS (1999)	526
ILLUSTRATED STAR WARS UNIVERSE, THE (1995)	663
IMMORTALS (2011)	526
IN THE MOUTH OF MADNESS (1994)	526
INCEPTION (2010)	171
INDEPENDENCE DAY (1996)	172 - 173, 527
INDIANA JONES AND THE KINGDOM OF THE CRYSTAL SKULL (2008)	180 - 183, 530
INDIANA JONES AND THE LAST CRUSADE (1989)	178 - 179, 529
INDIANA JONES AND THE RAIDERS OF THE LOST ARK (1981)	174 - 177, 527 - 529
INDIANA JONES AND THE TEMPLE OF DOOM (1984)	177, 529
INDUSTRIAL LIGHT & MAGIC (ILM)	635 - 647
INGLOURIOUS BASTERDS (2009)	184
INTERSTELLAR (2014)	530
INTERVIEW WITH THE VAMPIRE: THE VAMPIRE CHRONICLES (1994)	184
IRON MAN 3 (2013)	218 - 219
ISAAC ASIMOV'S INFERNO	342, 662
IT'S MY PARTY (1996)	514
<b>J</b>	
JAMES BOND: A VIEW TO A KILL (1985)	532
JAMES BOND: CASINO ROYALE (2006)	190 - 191, 533
JAMES BOND: DR. NO (1962)	184, 530
JAMES BOND: GOLDENEYE (1995)	532
JAMES BOND: QUANTUM OF SOLACE (2008)	193
JAMES BOND: SPECTRE (2015)	193
JAMES BOND: THE MAN WITH THE GOLDEN GUN (1974)	185, 531
JASON GOES TO HELL: THE FINAL FRIDAY (1993)	118, 487
JASON X (2001)	119, 488
JAY AND SILENT BOB STRIKE BACK (2001)	533
JEOPARDS! (2003)	534
JIM MORRISON	200
JINGLE ALL THE WAY (1996)	534
JOHN CARPENTER'S VAMPIRES (1998)	534
JOHN CARTER (2012)	535
JOHN CHAMBERS COLLECTION	283, 582 - 584
JOHN WICK: CHAPTER 3-PARABELLUM (2019)	194
JOJO RABBIT (2019)	535
JOURNEY 2: THE MYSTERIOUS ISLAND (2012)	535
JUDGE DREDD (1995)	195
JUMANJI (1995)	196 - 198
JUMANJI: WELCOME TO THE JUNGLE (2017)	199
JUPITER'S LEGACY (2021)	536
JURASSIC PARK (1993)	201 - 202, 536 - 537
JURASSIC PARK III (2001)	537
JURASSIC WORLD (2015)	205, 538
JURASSIC WORLD DOMINION (2022)	203 - 204
JURASSIC WORLD: FALLEN KINGDOM (2018)	205
<b>K</b>	
KARATE KID PART II, THE (1986)	206 - 207
KICK-ASS 2 (2013)	538
KING KONG (1976)	539
KINGPIN (1996)	538
KINGSMAN: THE GOLDEN CIRCLE (2017)	539

**DAY 01**

**LOTS 1 – 523**  
 PG. 6 – 411  
 JUNE 28, 2023  
 WEDS. 8:00 AM (PDT)  
 4:00 PM (BST)

**DAY 02**

**LOTS 524 – 1014**  
 PG. 412 – 555  
 JUNE 29, 2023  
 THUR. 8:00 AM (PDT)  
 4:00 PM (BST)

**DAY 03**

**LOTS 1015 – 1487**  
 PG. 556 – 697  
 JUNE 30, 2023  
 FRI. 8:00 AM (PDT)  
 4:00 PM (BST)

**Index**

Film or Show	Page Number(s)
NATURAL, THE (1984)	229 - 232, 231 - 566
NEW ADVENTURES OF PIPPI LONGSTOCKING (1988)	229
NIGHT OF THE LIVING DEAD (1968)	566
NIGHTMARE BEFORE CHRISTMAS, THE (1993)	232 - 234, 567 - 569
NIGHTMARE ON ELM STREET 3, A: DREAM WARRIORS (1987)	570
NIGHTMARE ON ELM STREET 4, A: THE DREAM MASTER (1988)	570
NIGHTMARE ON ELM STREET 5, A: THE DREAM CHILD (1989)	235 - 236, 570 - 571
NIGHTMARE ON ELM STREET PART 2, A: FREDDY'S REVENGE (1985)	236
NOTEBOOK, THE (2004)	569
<b>O</b>	
O BROTHER, WHERE ART THOU? (2000)	571
OCEAN'S ELEVEN (2001)	238, 572
OCTOPUSSY (1983)	531
ODD COUPLE II, THE (1998)	572
ONE HUNDRED AND ONE DALMATIANS (1961)	98
ORCA (1977)	572
ORIGINALS, THE (2013-2018)	573
ORVILLE, THE (2017)	573
OTHER BOLEYN GIRL, THE (2008)	239
OUT OF AFRICA (1985)	573
OUTBREAK (1995)	574
OUTLAND (1981)	574
<b>P</b>	
PACIFIC RIM (2013)	574
PACIFIC RIM UPRISING (2018)	575
PACIFIC, THE (2010-2010)	575
PANIC ROOM (2002)	575
PASSION OF THE CHRIST, THE (2004)	575 - 576
PAYBACK (1999)	576
PEARL HARBOR (2001)	577
PETER PAN (2003)	577
PIRANHA 3DD (2012)	577
PIRATES OF THE CARIBBEAN: DEAD MAN'S CHEST (2006)	578
PIRATES OF THE CARIBBEAN: ON STRANGER TIDES (2011)	578
PIRATES OF THE CARIBBEAN: THE CURSE OF THE BLACK PEARL (2003)	239 - 240, 577 - 578
PIXELS (2015)	579
PLANET OF THE APES (1968)	580 - 581
PLANET OF THE APES (2001)	585
PLANET OF THE APES MOVIES (1968-1973)	582
PLEASANTVILLE (1998)	585
POINT BREAK (1991)	241
POLAR EXPRESS, THE (2004)	586
POLTERGEIST (1982)	242
POLTERGEIST II: THE OTHER SIDE (1986)	246
POPEYE (1980)	586
PRANCER (1989)	587
PREDATOR (1987)	247, 587
PREDATOR 2 (1990)	587
PROMETHEUS (2012)	248 - 249, 588
PULP FICTION (1994)	250, 589
PUPPET MASTER: THE LITTLEST REICH (2018)	590
<b>Q</b>	
QUANTUM LEAP (1989-1993)	251
<b>R</b>	
RAISING ARIZONA (1987)	590
RAMBO (2008)	252
RAMBO III (1988)	252, 590

Film or Show	Page Number(s)
RAQUEL (1970)	591
RED HEAT (1988)	591
REIGN OF FIRE (2002)	591
RESIDENT EVIL: APOCALYPSE (2004)	253
RESIDENT EVIL: EXTINCTION (2007)	592
RETURN TO OZ (1985)	253
REVOLT OF MAMIE STOVER, THE (1956)	592
RISKY BUSINESS (1983)	254
ROBIN HOOD: PRINCE OF THIEVES (1991)	254, 592 - 595
ROBOCOP (2014)	255, 595
ROBOCOP 2 (1990)	255
ROBOT JOX (1989)	596
ROBOT VISIONS (1990)	341, 662
ROCKETEER, THE (1991)	596
ROCKFORD FILES (1974-1980)	597
ROCKY BALBOA (2006)	597
ROCKY III (1982)	597
ROYAL PERFORMANCE	508
RUSH HOUR (1998)	597 - 598
SAHARA (2005)	598
SAW IV (2007)	258
SCARFACE (1983)	256 - 257
SCREAM 2 (1997)	258 - 259
SCREAM 3 (2000)	599
SCREAM 4 (2011)	599
SCRUBS (2001)	599
SERENITY (2005)	260, 599 - 601
SEVEN PSYCHOPATHS (2012)	601
SEVEN YEAR ITCH, THE (1955)	260, 601
SEX AND THE CITY (2008)	601
SHADOW, THE (1994)	602
SHAMELESS (2011-2021)	602
SHAWSHANK REDEMPTION, THE (1994)	261 - 267
SIGNS (2002)	268
SILENT HILL (2006)	602
SILVER LININGS PLAYBOOK (2012)	602
SINISTER 2 (2015)	603
SKYFALL (2012)	191 - 192, 533
SLEEPY HOLLOW (1999)	603 - 604
SLEEPY HOLLOW (2013-2017)	604
SMALLVILLE (2001-2011)	268
SOLAR PRODUCTIONS	356 - 357
SOLARBABIES (1986)	604 - 605
SOPRANOS, THE (1999-2007)	605
SPACE JAM: A NEW LEGACY (2021)	605
SPACE: FANTASY AND REALITY	662
SPACEBALLS (1987)	269, 606
SPECTRAL (2016)	606
SPIDER-MAN (1977-1979)	270
SPIDER-MAN (2002)	272, 606 - 607
SPIDER-MAN (2002) / SPIDER-MAN 2 (2004)	607
SPIDER-MAN 2 (2004)	607 - 608
SPIDER-MAN 3 (2007)	608
STAR JAWS (1978)	654 - 655
STAR TREK (2009)	614 - 615
STAR TREK FRANCHISE (1966-PRESENT)	614
STAR TREK II: THE WRATH OF KHAN (1982)	275, 611, 615
STAR TREK III: THE SEARCH FOR SPOCK (1984)	276, 611 - 612
STAR TREK INTO DARKNESS (2013)	616 - 617
STAR TREK IV: THE VOYAGE HOME (1986)	276, 612
STAR TREK IV: THE VOYAGE HOME (1986)/STAR TREK: GENERATIONS (1986)	278
STAR TREK V: THE FINAL FRONTIER (1989)	277, 613
STAR TREK: DEEP SPACE NINE (1993-1999)	286 - 287, 615, 624 - 626



**DAY  
01**

**LOTS 1 - 523**  
PG. 6 - 411  
JUNE 28, 2023  
WEDS. 8:00 AM (PDT)  
4:00 PM (BST)

**DAY  
02**

**LOTS 524 - 1014**  
PG. 412 - 555  
JUNE 29, 2023  
THUR. 8:00 AM (PDT)  
4:00 PM (BST)

**DAY  
03**

**LOTS 1015 - 1487**  
PG. 556 - 697  
JUNE 30, 2023  
FRI. 8:00 AM (PDT)  
4:00 PM (BST)

**Index**

Film or Show	Page Number(s)	Film or Show	Page Number(s)
STAR TREK: DEEP SPACE NINE (1993-1999)/STAR TREK: VOYAGER (1995-2001)	625	TEXAS CHAINSAW MASSACRE, THE: THE BEGINNING (2006)	679
STAR TREK: ENTERPRISE (2001-2005)	628	THELMA & LOUISE (1991)	680
STAR TREK: FIRST CONTACT (1996)	616	THING, THE (1982)	374, 680
STAR TREK: GENERATIONS (1994)	277, 613	THING, THE (2011)	373
STAR TREK: PICARD (2020-2023)	629	THOR (2011)	547
STAR TREK: THE ANIMATED SERIES (1973-1974)	620	THOR: LOVE AND THUNDER (2022)	220 - 221, 547
STAR TREK: THE MOTION PICTURE (1979)	272 - 274, 608 - 611	TICKS (1993)	681
STAR TREK: THE NEXT GENERATION (1987-1994)	284 - 286, 621 - 624	TITANIC (1997)	378 - 380, 681
STAR TREK: THE ORIGINAL SERIES (1966-1969)	279 - 282, 284, 618 - 621	TOP GUN (1986)	381 - 382
STAR TREK: VARIOUS PRODUCTIONS	609 - 614	TOTAL RECALL (1990)	681
STAR TREK: VOYAGER (1995-2001)	287, 626 - 627	TRANSFORMERS: AGE OF EXTINCTION (2014)	681
STAR WARS TOYS	345, 351, 643	TRICK 'R TREAT (2007)	373
STAR WARS: EPISODE I - THE PHANTOM MENACE (1999)	288 - 299, 629 - 630	TRON (1982)	382
STAR WARS: EPISODE II - ATTACK OF THE CLONES (2002)	630	TROY (2004)	383 - 387, 682
STAR WARS: EPISODE III - REVENGE OF THE SITH (2005)	300 - 304, 630 - 631	TRUE LIES (1994)	682
STAR WARS: EPISODE IV - A NEW HOPE (1977)	305 - 336, 632 - 654	TRUMAN SHOW, THE (1998)	682
STAR WARS: EPISODE V - THE EMPIRE STRIKES BACK (1980)	325 - 329, 337, 350, 644 - 649, 655	TWILIGHT (2008)	388 - 389, 683
STAR WARS: EPISODE VI - RETURN OF THE JEDI (1983)	330 - 335, 649 - 661	TWILIGHT SAGA, THE: BREAKING DAWN-PART 1 (2011)	684
STAR WARS: EPISODE VII - THE FORCE AWAKENS (2015)	351 - 353, 664	TWILIGHT SAGA, THE: BREAKING DAWN-PART 2 (2012)	389, 684
STAR WARS: EPISODE VIII - THE LAST JEDI (2017)	664	TWILIGHT SAGA, THE: ECLIPSE (2010)	388
STAR WARS: ORIGINAL TRILOGY (1977-1983)	346 - 350, 633 - 659	TWILIGHT ZONE, THE (1959-1964)	390
STAR WARS: PREQUEL TRILOGY (1999-2005)	299, 631	<b>U</b>	
STAR WARS: STAR TOURS (1987)	340	ULTRAVIOLET (2006)	390
STAR WARS: THE COMPLETE SAGA	663	UNBREAKABLE (2000)	685
STAR WARS: THE EMPIRE STRIKES BACK (1980)/STAR WARS: RETURN OF THE JEDI (1983)	325	UNDERWORLD (2003)	391 - 393, 685
STAR WARS: THE MOS EISLEY CANTINA POP-UP BOOK (1995)	345	UNDERWORLD: AWAKENING (2012)	686
STAR WARS: THE PHANTOM MENACE (1999)/STAR WARS: ATTACK OF THE CLONES (2002)	298	UNDERWORLD: RISE OF THE LYCANS (2009)	685 - 686
STAR WARS: VARIOUS PRODUCTIONS	343, 638, 657 - 660	UNKNOWN PRODUCTION	684
STARDUST (2007)	354	<b>V</b>	
STARGATE (1994)	664	VAN HELSING (2004)	686 - 687
STARGATE SG-1 (1997-2007)	355, 665	VARIOUS PRODUCTIONS	322 - 323, 460, 582
STARGATE: THE ARK OF TRUTH (2008)	665	VENOM (2018)	393
STARSHIP TROOPERS (1997)	354, 665 - 666	<b>W</b>	
STEAL THE SKY (1988)	666	WALKING DEAD, THE (2010-2022)	394 - 395, 687 - 690
STEVEN SPIELBERG	528	WALT DISNEY WORLD	96
STOP OR MY MOM WILL SHOOT (1992)	514	WAR OF THE WORLDS (2005)	403
STUART LITTLE (1999)	515	WARCRAFT (2016)	396 - 402, 691 - 695
SUCKER PUNCH (2011)	358, 667	WARM BODIES (2013)	695
SUICIDE SQUAD (2016)	359, 667	WHIPLASH (2014)	695
SUICIDE SQUAD, THE (2021)	668	WHO FRAMED ROGER RABBIT (1988)	696
SUPERGIRL (1984)	361	WOLFMAN, THE (2010)	403 - 404
SUPERMAN (1978)	359	WONDER WOMAN (2017)	404 - 405
SUPERMAN (1978)/SUPERMAN II (1980)	668	WORLD IS NOT ENOUGH, THE (1999)	188 - 190, 532
SUPERMAN (1978)/SUPERMAN III (1983)	669	<b>X</b>	
SUPERMAN AND THE MOLE MEN (1951)	668	X2: X-MEN UNITED (2003)	406 - 409
SUPERMAN II (1980)	668 - 669	XENA: WARRIOR PRINCESS (1995-2001)	410
SUPERMAN III (1983)	360	X-FILES, THE (1993-2018)	409, 697
SUPERMAN IV: THE QUEST FOR PEACE (1987)	360		
SUPERMAN LIVES (2015)	669		
SUPERNATURAL (2005-2020)	361		
SURROGATES (2009)	670		
<b>T</b>			
TALES FROM THE CRYPT (1989-1996)	670 - 671		
TALES FROM THE CRYPT PRESENTS: BORDELLO OF BLOOD (1996)	671		
TANK GIRL (1995)	671 - 674		
TAPS (1981)	674 - 675		
TEAM AMERICA: WORLD POLICE (2004)	362 - 368		
TED 2 (2015)	369		
TERMINATOR 2: JUDGMENT DAY (1991)	370 - 371, 373, 676		
TERMINATOR 3: RISE OF THE MACHINES (2003)	372		
TERMINATOR GENISYS (2015)	678		
TERMINATOR SALVATION (2009)	677		
TERMINATOR, THE (1984)	675 - 676		
TERMINATOR: DARK FATE (2019)	678 - 679		

# Propstore

## Online Collectible Posters Auction

Aug 10 - Sept 7, 2023



London

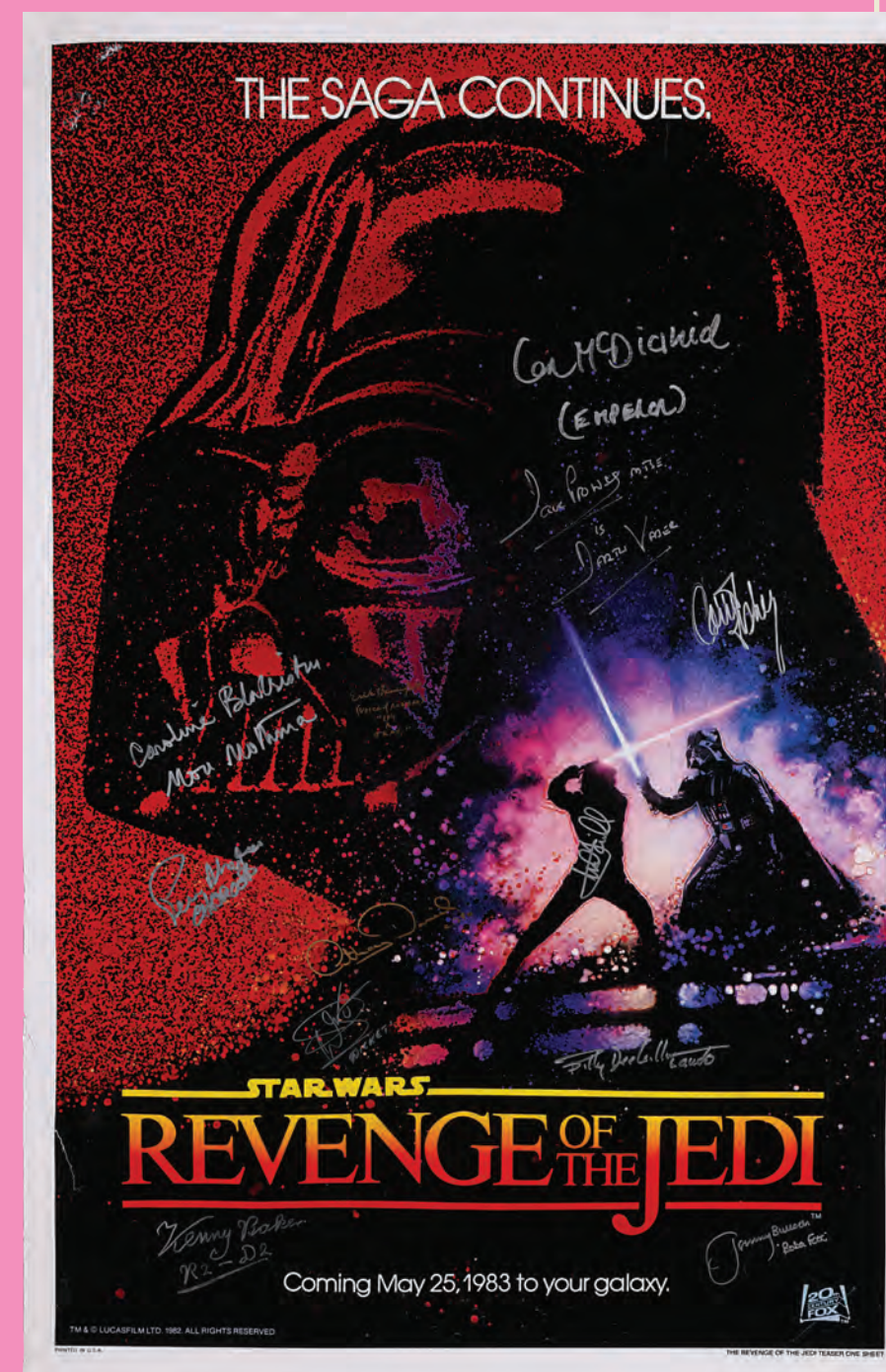

**Star Wars: Return Of The Jedi (1983)**  
Cast Autographed Original "Revenge"  
Teaser US One-Sheet

Estimate: £3,000-6,000



Propstore CA Bond #7285804416



Propstore

# Entertainment Memorabilia Live Auction

Treasures from Film and Television

Nov 9 - 12, 2023



London

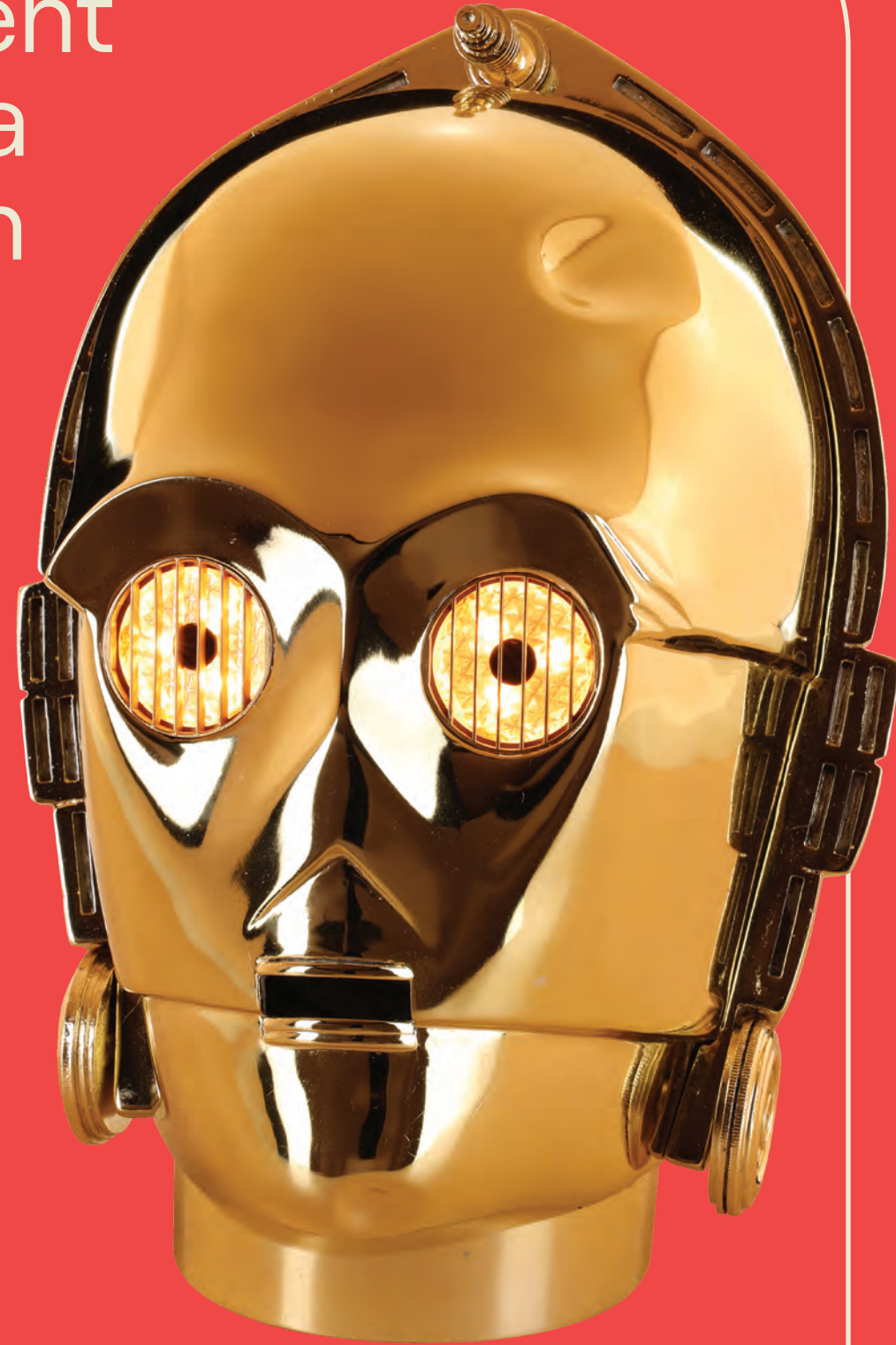

## Star Wars: A New Hope (1977)

Anthony Daniels Collection: Screen-Matched Light-up C-3PO (Anthony Daniels) Head

Estimate: £500,000 - £1,000,000



Propstore CA Bond #7285BGU4116



### Propstore Live Auction Bidder Registration Form

Sale Name: Entertainment Memorabilia Live Auction: Los Angeles

Sale Date: June 28 - 30, 2023

Bidder Name: \_\_\_\_\_

Bidder Number: \_\_\_\_\_

Preferred Telephone No: \_\_\_\_\_

Secondary Telephone No: \_\_\_\_\_

Select One: Telephone Bidder  Absentee Bidder

The following are suggested bid increments for the Auction. Please be advised that they are suggested increments only, are not intended to be and shall not be binding, and the Auctioneer retains the sole and absolute discretion, at the time of the Auction, to change, modify, or vary the bid increments at any time.

- \$100 - 300 by \$25
- \$300 - 500 by \$50
- \$500 - \$2,000 by \$100
- \$2,000 - \$5,000 by \$250
- \$5,000 - \$10,000 by \$500
- \$10,000 - \$20,000 by \$1,000
- \$20,000 - \$50,000 by \$2,500
- \$50,000 - \$100,000 by \$5,000
- \$100,000+ at the Auctioneer's discretion

**Auction Lot #**

**Description of Lot**

**Bid Excluding Premium**  
(\*Absentee Bidders Only)

Auction Lot #	Description of Lot	Bid Excluding Premium (*Absentee Bidders Only)

✂ A Buyer's Premium of 25% will be added to all winning bids. For any orders over \$5,000 paid via credit card, a fee of 2% of the Purchase Price will be added. Submit your completed form to supportla@propstore.com

# Propstore

## Propstore Live Auction Bidder Registration Form

**Sale Name:** Entertainment Memorabilia Live Auction: Los Angeles

**Sale Date:** June 28 – 30, 2023

### BIDDER INFORMATION

(If bidding as agent, complete one form as the third-party bidder and a second form as the agent. Both sets of contact information are required.)

Paddle Number (Propstore Use Only): \_\_\_\_\_ Cell Phone: \_\_\_\_\_

Name: \_\_\_\_\_ Business Phone: \_\_\_\_\_

Business Name (if applicable): \_\_\_\_\_ Fax: \_\_\_\_\_

Mailing Address (include country): \_\_\_\_\_ Email: \_\_\_\_\_

\_\_\_\_\_ Credit Card Type (Visa, MC or AmEx): \_\_\_\_\_

\_\_\_\_\_ Credit Card Number: \_\_\_\_\_

Shipping Address (include country): \_\_\_\_\_ Credit Card Expiration Date: \_\_\_\_\_

\_\_\_\_\_ Registering as (select one): Private Client  Trade Client

Company Registration No. (if applicable): \_\_\_\_\_ Reseller's Permit (if applicable): \_\_\_\_\_

Home Phone: \_\_\_\_\_

### BIDDER NOTICES – PLEASE READ

- If you wish to make a bid at a Propstore Live Auction, you must pre-register with Propstore on this form.
- If registering as an individual, you must provide Propstore with at least one (1) form of ID which must include one (1) government issued photo identification. If this does not state your current address, proof of address will also be required.
- If registering as an organization, you must provide a certified copy or original certificate of incorporation, or, in the case of unregistered entities, other evidence satisfactory to Propstore – contact Propstore at **+1 818 727 7829** for confirmation or what will be acceptable.
- If you are registering as an agent to bid on behalf of another party, you must produce the relevant ID documents at paragraphs 2 and 3 above for yourself and the person or organization on whose behalf you are acting. In addition, you must provide to Propstore a written and signed authority from the third party confirming your authority to bid on their behalf.
- BY COMPLETING AND SUBMITTING THIS BIDDER REGISTRATION FORM, YOU ACKNOWLEDGE YOU HAVE READ, UNDERSTAND AND AGREE TO BE BOUND BY PROPSTORE'S LIVE AUCTION CONDITIONS OF SALE (COPIES AVAILABLE IN THE AUCTION BUYER'S GUIDE, ON PROPSTORE'S WEBSITE propstore.com OR ON REQUEST FROM PROPSTORE) AND PRIVACY POLICY (AVAILABLE ON PROPSTORE'S WEBSITE propstore.com)
- In particular, please make yourself aware of Propstore's payment terms, with all sums due within 7 working days from receipt of Propstore's invoice. Propstore WILL ONLY ACCEPT PAYMENT FROM THE BUYER.

For full details on how we handle and process your data including identity and payment verification please see our website. By registering for the auction you consent to us using your personal data for this purpose including verifying the information you provide to us matches with public and other records.

**Telephone Bidders:** Telephone bidders must complete this form to provide Propstore a list of Lots on which they intend to bid at least 24 hours before the start of the auction.

**Absentee Bidders:** Written bids will be executed at the lowest possible price, taking into account the Reserve Price. Absentee Bidders must complete this form to provide Propstore with written bids at least 24 hours before the start of the Auction

Select One: Telephone Bidder

Absentee Bidder

I, the undersigned, have read and agreed to the terms and conditions of the sale, read and understood the privacy policy and am over 18 years of age

(Signature)

(Date)

**A Buyer's Premium of 25% will be added to all winning bids. For any orders over \$5,000 paid via credit card, a fee of 2% of the Purchase Price will be added. Submit your completed form to supportla@propstore.com**



### Propstore – London Office

Stephen Lane, CEO  
Lizzie Lane, Director  
Guy Pettigrew, CFO  
Tim Lawes, Director of Consignments  
Siân Taylor, Director of Operations  
Mark Hochman, Director of Consignments: Music & Posters  
Alex Packham, Non-Executive Director  
Cathy Dawson, Head of Finance  
Viki Merry, Operations Manager  
Sarah Sorkin, Photography & Video Manager  
Miranda McCabe, Marketing Manager  
Graham Terry, Warehouse Manager  
Paul Wallis, Facilities & HR Manager  
Luke Cozens, Shipping Manager  
Shane Tewiah, Project Manager  
Priya Mudgil, Senior Administrator  
Chris Aikman, Senior Copywriter & Researcher  
Amy Turnbull, Copywriter & Researcher  
Taher Moosavi, Copywriter & Researcher  
Katie Males, Copywriter & Researcher: Music & Posters  
Jamie Dalton, Shipping & Export Clerk  
George Dupree, Photographer & Videographer  
Robert Aikman, Photographer & Assistant Videographer  
Melody Liu, Video & Graphic Designer  
Richard Airey, Shipping Assistant  
Matt Storey, General Assistant  
Sam Dietz, General Assistant  
Alex Howard, Social Media & Press Associate  
Devon Cozens, Senior Administrator  
Ibrahim Faraj, Consignments Administrator

**Telephone – +44 (0) 01494 766485**  
**Email – support@propstore.com**

### Propstore – Los Angeles Office

Brandon Alinger, Global COO & President, North America  
Chuck Costas, VP, Business Development and Marketing  
Greg Giroux, VP, IT Development  
Don Barnett, Director of Operations  
Art Andrews, Director of Consignments  
Maegan Hensley, Director of Asset Management  
Grey Smith, Director of US Poster Auctions  
Dan Hill, Senior Manager, Consignments & Conventions  
Justin Miller, Senior Manager, Photography  
Anthony Gonzalez, Manager, Graphics  
Tami Garcia, Finance & Administration Manager  
Sean L. Malin, Copy Manager  
Franky Berrios, Shipping Manager  
Jamie Jamitkowski, Senior Manager, Marketing  
Jason Coleman, Poster Specialist, Consignments  
Jim Mossey, Sourcing Manager, Consignments  
Natalie Rocha, Jr. Analyst, Consignments  
Joe Beaudoin, Jr. Analyst, Buy Now  
Steven Brown, IT Supervisor  
Danny Darin, IT Associate  
Zachary Hyzy, Data Analysis Supervisor  
Paul Gonzalez, Warehouse Supervisor  
Charles Warr, Design Supervisor, Graphics  
Kellina James, Assistant Supervisor, Graphics  
Jaret Sears, Assistant Supervisor, Copy  
Raeann Briones-Almaguer, Copy Associate  
Rachel Herbert, Copy Associate  
Lauren Shand, Jr. Assistant, Consignments Sourcing  
John Cooley, Jr. Assistant, Consignments Sourcing  
Wendy Allen, Jr. Assistant, Consignments Goods-In  
Kiley Bishop, Photographer  
Lori Sandoval, Photographer  
Antonia Fox, Photography Associate  
Tanner Burghardt, Photography Associate  
Devin Lotfi, Photography Associate  
Cameron Rookey, Photography Assistant  
Lyle Mauricio, Photography Assistant  
Ryan Gibson, Customer Service & Admin, Sr. Associate  
Adam Woodring, Shipping Associate  
George Penley, Shipping, Sr. Associate  
Brennan Mann, Warehouse Associate  
Jarrod Kirkness, Jr. Assistant, Consignments Goods-In  
Fernando Lomeli, Intake Assistant  
Alyson Bataille, Intake Assistant  
Sean McBride, Warehouse Assistant  
Vincent Lorentz as Shipping Assistant

**Telephone – +1 818-727-7829**  
**Email – supportla@propstore.com**

### BACK COVER IMAGES

<b>198</b> Director Joe Dante's Gremlin Puppets <b>Gremlins (1984)</b>	<b>185</b> General Maximus' (Russell Crowe) Screen-Matched Dress Cuirass <b>Gladiator (2000)</b>
<b>280</b> Peter Quill's (Chris Pratt) Light-Up "Star-Lord" Helmet <b>Guardians Of The Galaxy (2014)</b>	
<b>108</b> Batman's (Christian Bale) Batpod <b>The Dark Knight (2008)/The Dark Knight Rises (2012)</b>	

### Catalog Creative Team

**Designers:**  
Anthony Gonzalez, Charles Warr, Kellina James, Sarah Cierlak, Tony Mendoza, Wade Lageose

**Photographers:**  
Justin Miller, Lori Sandoval, Kiley Bishop, Lyle Mauricio, Antonia Fox, Cameron Rookey, Devin Lotfi, Tanner Burghardt, Sarah Sorkin, Robert Aikman, George Dupree

**Copywriters:**  
Sean L. Malin, Jaret Sears, Rachel Herbert, Raeann Briones-Almaguer, Joe Beaudoin, Chris Aikman, Katie Males, Amy Turnbull, Taher Moosavi

**Editor:**  
Shelley Moench-Kelly

**Researcher:**  
Christy Andrews

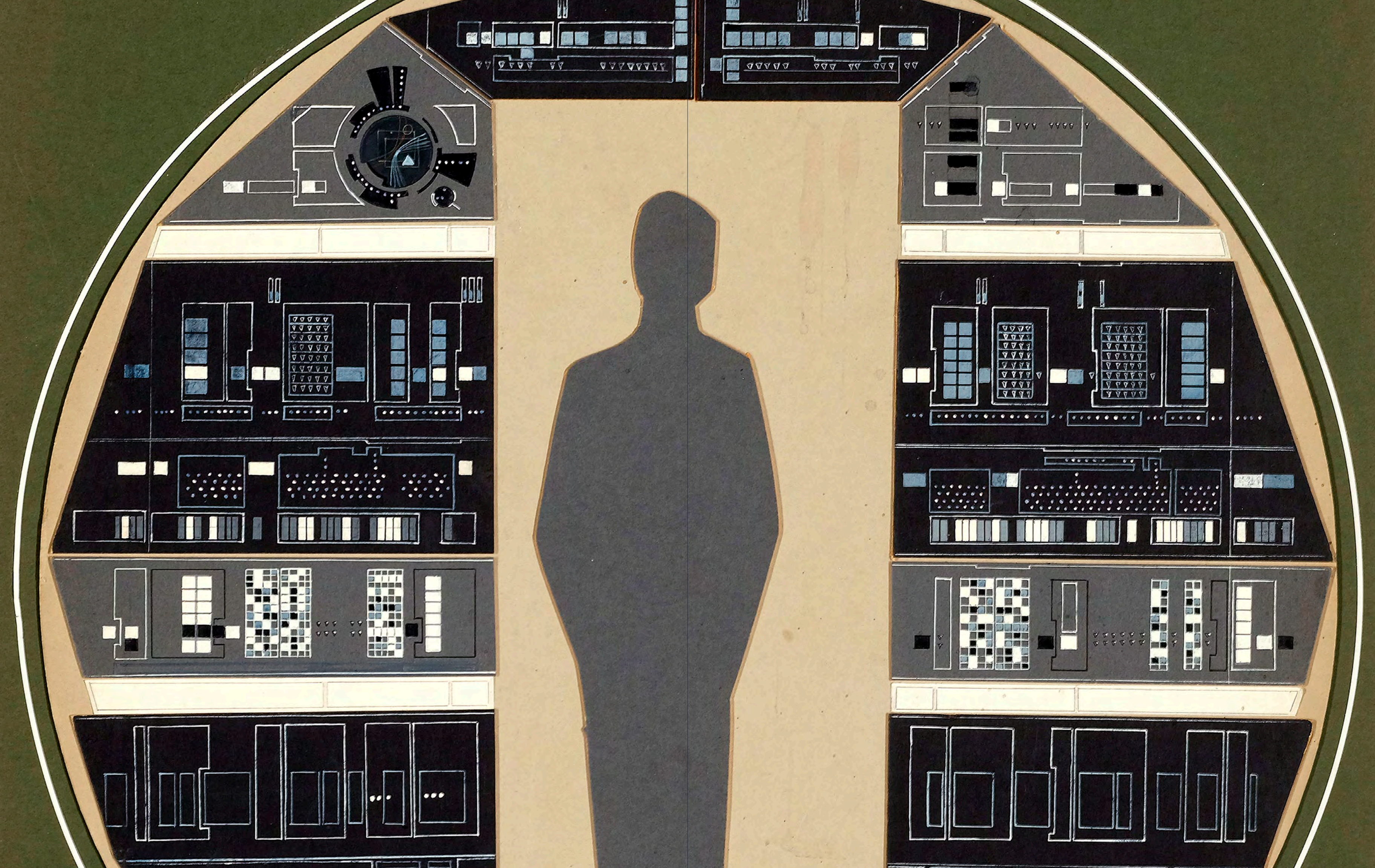



[propstore.com/liveauction](http://propstore.com/liveauction)