

Propstore

Entertainment Memorabilia Live Auction



Film and Television
Treasures



London

Nov 3 - 6, 2022

Dear Warden,
 You were right,
 Salvation lay within
 Andy Dupresne

Moses' birth. His adoption. His flight to Midian EXODUS, 1

women are not as the Egyptian women; for they are lively, and are delivered as soon as they come to term.

20 With my lips have I declared the judgments of thy mouth. I have rejoiced in the way of thy statutes, as much as

21 And it came to pass that the midwives feared God, and made them houses unto thyself in thy presence.

22 And Pharaoh charged all the Egyptians, saying, Every son that is born ye shall cast into the river, and every daughter ye shall keep alive.

[52] CHAPTER 2
 The Birth and Youth of Moses

AND there went a man of the house of Levi, and his wife bare him a son: and when she saw him that he was a goodly child, she hid him three months.

3 And when she could no longer hide him, she took him an ark of bulrushes, and daubed it with slime and pitch, and put the child therein; and she laid it in the flags by the river's brink.

4 And his sister stood afar off, to wit what would be done to him.

5 ¶ And the daughter of Pharaoh came down to wash herself at the river; and her maid walked along by the river

8 And Pharaoh's daughter said to her, Go. And the maid went and called the child's mother.

9 And she said, Let the child live, and I will nurse it.

10 And the child grew, and she brought him unto Pharaoh's daughter, and he became her son. And she called his name Moses: and she said, Because I drew him out of the water.

11 ¶ And it came to pass in those days, when Moses was grown, that he went out unto his brethren, and looked on their burden, and he spied an Egyptian smiting a Hebrew, one of his brethren.

12 And he looked this way that way, and when he saw there was no man, he slew the Egyptian, and hid him in the sand.

13 And when he went out the second day, behold, two men of the Hebrews strove together; and he said to him that did wrong, Wherefore smitest thou thy fellow?

14 And he said, Who made thee a prince and a judge over us? intendest thou to kill me, because thou killedst the Egyptian?

15 Now when Pharaoh heard this thing, he sought to slay

Entertainment Memorabilia Live Auction

Nov 3 – 6, 3:00 PM (GMT)
Hosted Live From BAFTA 195 Piccadilly
St. James's,
London
W1J 9LN
England
+44 (0) 1494 766485

Bidding is available in-person, online, via telephone and via written absentee form. Bidders are advised to arrive early to register for in-person bidding, or to register in advance of the auction days for online, telephone or absentee bidding. Please see the bidding registration document at the back of the catalog for additional information.

Lots are auctioned live and in-person by Propstore's auctioneer in sequential order. The catalog identifies which day each lot will be offered. The live auction is streamed online at Propstore.com so bidders can follow all auction activity.

Online Auction Catalogue & Additional Lot Information

The online catalog for this auction contains multiple high-resolution photographs for all lots offered. Reviewing the online catalog prior to bidding is highly recommended. Absentee bids can also be placed in the online catalog.

Video footage is available for select lots, and condition reports are available upon request. Additional video coverage is available on Propstore's YouTube channel, and multiple live video streams showcasing auction Lots will run on Propstore's social media in the weeks before the auction. **Propstore.com/Auction**

How To Bid

In-Person

Bidders are invited to attend the live auction event in-person at BAFTA. Please arrive early to register for the auction; you will complete a copy of the bidder registration form on page 685.

Telephone

Complete the bidder registration form on page 685 to bid via telephone. One of Propstore's telephone bidding specialists will call you at your specified number and allow you to bid on your lot in real time.

Online

Bid live from anywhere in the world via Propstore's live online Auction Platform. Register today at Propstore.com/Auction

Absentee Form

Complete the bidder registration form on page 685 to bid via written absentee form. Mark that your bids are absentee bids, list your maximum bid (a clerk will execute on your behalf) and submit the form to Propstore.

Bidding on High-Value Lots

New clients who have no prior purchase history with Propstore may need to meet additional registration requirements in order to bid on lots that have a low estimate of £50,000 and above. Please inquire for details.

Terms & Info

Buying with Propstore

For an overview of how to participate in this auction as a buyer, please refer to the Buyer's Guide on page 672 of this catalog.

Conditions of Sale

This auction is governed by important stipulated terms, conditions and reserves. All stipulations can be found at propstore.com/liveauction. Please note, some of the items in this sale attract VAT (see clause 7.9.) Due to the US Wayfair ruling, US sales tax may apply to US buyers from select US states (see clause 7.23.)

Buyer's Premium

A Buyer's Premium of 25% will be added to all winning bids.

Previewing Auction Lots

Lots can be previewed by special appointment at Propstore's London facility. These special appointment previews can be facilitated through 4th October. Lots can also be previewed via electronic video calls. Contact us for additional information.

Payment Plans

Payment plans may be available in increments of up to three (3) months for purchases where total Hammer Price and Buyer's Premium are greater than £1,000. Buyers wishing to utilize the payment plan service, if approved by Propstore, shall be required to pay a deposit of twenty percent (20%) of the Purchase Price (the "Deposit"), within seven (7) business days of being invoiced. The balance of the Purchase Price shall then be split over up to three (3) months, at the Buyer's option.

Reserves

Certain Lots in this auction may be sold without a Reserve Price; the majority of Lots in this auction are sold with a Reserve Price. The Reserve Price is the minimum price the Seller will accept for a Lot. The Reserve Price will not be more than the lowest estimate given by Propstore. Propstore may disclose or keep confidential the Reserve Price at its entire discretion.

Live Auction Stream

The complete live auction event will be broadcast on propstore.com and viewable from anywhere in the world. Lots are sold in sequential order.

Bidding Increments

The following are suggested bid increments for the Auction. Please be advised that they are suggested increments only, are not intended to be and shall not be binding, and the Auctioneer retains the sole and absolute discretion, at the time of the Auction, to change, modify, or vary the bid increments at any time.

- £10 - £50 by £10
- £50 - £300 by £25
- £300 - £500 by £50
- £500 - £1,000 by £100
- £2,000 - £5,000 by £250
- £5,000 - £10,000 by £500
- £10,000 - £20,000 by £1,000
- £20,000 - £50,000 by £2,500
- £50,000 - £100,000 by £5,000
- £100,000+ at the Auctioneer's discretion

VAT and Sales Tax

All stipulations can be found at propstore.com/liveauction. Please note, some of the items in this sale attract VAT (see clause 7.9.) Due to the US Wayfair ruling, US sales tax may apply to US buyers from select US states (see clause 7.23.)

Follow the auction on Propstore's social media platforms **#PropstoreLiveAuction**



Propstore

Entertainment Memorabilia Live Auction

London | Nov 3 – 6, 2022

Day 1

Lots 1 – 448
Nov 3

Film & Television

Thurs. 3:00 PM (GMT)
8:00 AM (PDT)

Day 2

Lots 449 – 623
Nov 4

Music

Fri. 3:00 PM (GMT)
8:00 AM (PDT)

*see separate catalog
containing Music Lots

Day 3

Lots 624 – 1083
Nov 5

Film & Television

Sat. 3:00 PM (GMT)
8:00 AM (PDT)

Day 4

Lots 1084 – 1536
Nov 6

Film & Television

Sun. 3:00 PM (GMT)
7:00 AM (PST)

*US clocks change
between auction
days 3 and 4

Auction Begins 3:00 PM (GMT) Each Day

Propstore.com/Auction

* Certain films and shows have Lots offered on more than one day of the Auction; see Index on page 681 for a complete listing of available Lots by film or show title

FRONT COVER IMAGE

406
Superman's (Christopher Reeve) Complete Costume M
Superman Franchise (1978–1987)

About Propstore

Propstore was founded on the belief that the props and costumes used in movies are pieces of art—film art. We see these artifacts not as mere byproducts of the production process, but as unique, creative works in their own right. The result of the collective effort of designers, fabricators, and artisans from every corner of the globe, many of these pieces are simply extraordinary.

Private collectors have played a significant role in preserving these film art pieces since the earliest days of cinema and television. Throughout the entertainment industry's history, these items were considered as mere production tools and were therefore commonly discarded time and time again. Private collectors have stepped in on many occasions and taken preservation into their own hands. Some film and television artifact collecting stories are legendary: A college student walking through a field and stumbling upon the model miniature space station from 2001: A Space Odyssey after the item was dumped from an unpaid storage locker, for example. Many of cinema's most memorable treasures are cared for by private collectors, and we believe that private collectors continue to play a critical role in the overall preservation and legacy of film and television history. Collecting is a very personal thing as all collectors have different tastes—but collectors are united through a common passion for the material and its preservation.

Each of Propstore's team members share this belief and are long-time, passionate collectors themselves. We love this material. We revere this material. Our enthusiasm is the driving force in our nearly two decade global search to locate these culturally-significant items. Our journey has enabled us to forge key relationships within the

industry that have provided access to material previously believed to be unavailable. We are also in continuous contact with those on the front lines of production. These individuals educate us and assist us in properly identifying and authenticating material. In turn, we have educated and supported the collecting community by sharing our knowledge through articles, videos and collecting websites and forums.

We are excited to share this catalog with collectors around the world. Within this sale you will find pieces available at every price point—all of which are authenticated and certified with our industry-leading certificate of authenticity and its accompanying guarantee. Each of these pieces satisfy our strict internal authentication standards.

We strive to present these pieces with the same level of care that went into their presentation on screen, as they deserve nothing less. A large portion of the artifact collection will be on public exhibition prior to the sale, providing a first-hand view of the material. Whether you are a veteran collector or just getting started, we hope that you find pieces that speak to you amongst this truly unique offering. To make this material more accessible, every item can be purchased on an interest-free payment plan. We can also pack and ship material safely to any destination in the world.

Our experience, passion and desire to source the most exciting pieces possible makes us one of the world's leading vendors of original props, costumes and collectable memorabilia. We look forward to being a part of your own collecting journey and to helping you preserve these beloved pieces of film and television history.

The Propstore Certificate of Authenticity

Authenticity is the defining collectable element for original music memorabilia. All of our certificates carry multiple security elements to verify authenticity, representing a lifetime guarantee that the item is a genuine piece of music history exactly as described. Propstore's complete Terms of Guarantee can be found on page 678.



Propstore Wanted

Props, Costumes and Artifacts from Movies and Television

propstore.com/sell



Day 1

Lots 1 - 448.
Nov 3, 2022



'U

*Certain films and shows have Lots offered on more than one day of the Auction; see Index on page 681 for a complete listing of available Lots by film or show title

1 Discovery Pod Concept Model M 2001: A Space Odyssey (1968)

A Discovery pod concept model from Stanley Kubrick's sci-fi epic 2001: A Space Odyssey. The spaceship Discovery had several EVA pods, and Drs. Bowman (Keir Dullea) and Poole (Gary Lockwood) met in one to prevent HAL from hearing their conversation.

This wooden model was constructed during the concept stage of the production and provided a basis for miniature models and the full-size craft used during the shoot. The concept model can be seen in a production still showing the pod in the art department next to Stanley Kubrick on page 383 of The Stanley Kubrick Archives, edited by Alison Castle. Very few items from the production have survived to the present day, as many were destroyed after the production wrapped. This model was a vital part of the visual effects process, which created landmark effects, considered excellent to this day.

Painted white, the model has hand-drawn pencil markings indicating the positioning of lights and additional details, some of which are seen in the final iteration created for filming, indicating that this model was a significant tool in the development of the design for the pod. The model has wear from age and use, with sections of the wood exposed at the front, and chips and additional markings all over. It sits on a custom-made mirrored display stand, so its underside can be easily viewed. Dimensions (model): 27 cm x 29 cm x 27 cm (10 3/4" x 11 1/2" x 10 3/4")

Estimate. £15,000 - 25,000



Production still excerpt from The Stanley Kubrick Archives, edited by Alison Castle

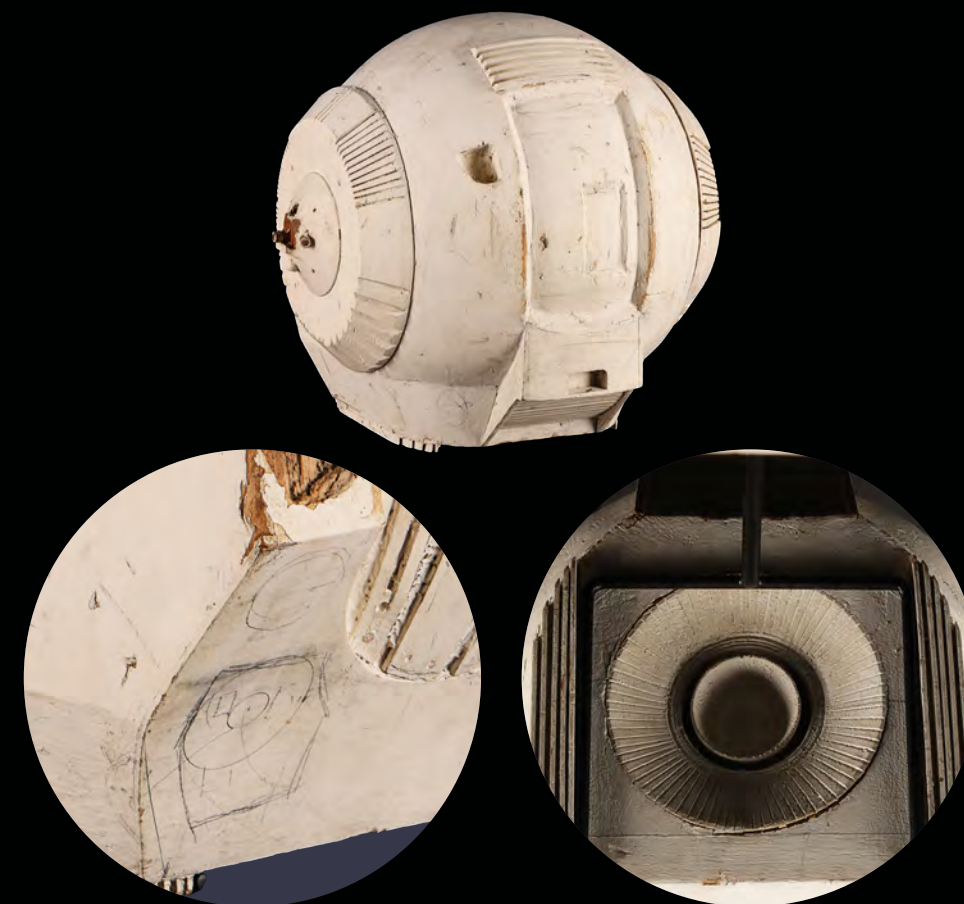

2
Light-Up Orion III
 Replica Model-Miniature us
2001: A Space Odyssey (1968)

A light-up Orion III replica model miniature from Stanley Kubrick's sci-fi epic 2001: A Space Odyssey. Dr. Heywood Floyd (William Sylvester) travelled to Clavius Base aboard the Orion III spaceplane from Earth.

This lot consists of a detailed, custom-made replica model miniature of the Orion III, a display base, and various materials related to its construction including nine vacuum-forming patterns, thirteen mould pieces, and a collection of blueprints and paperwork. The Orion III model is constructed of vacuum-formed ABS and plexiglass with an aluminium armature plate. It was built using original reference materials to be as accurate as possible, and the build was assisted by 2001 experts Piers Bizony and Simon Atkinson. The piece features a fully lit cabin interior, navigation and landing lights on the wings, and cockpit lights; the engine lights are present but not currently functional and are not readily accessible for repair. The front lighting systems can be accessed through the model's removable nose section.

Initially a commission for the Museum of Science Fiction in Washington D.C., this model also featured in an exhibit at the Reagan National Airport and the Maryland Science Centre in Baltimore. The Orion III was also the focus of a special display at Wonderfest 2015 in Louisville, Kentucky. It is believed to be one of the most accurate replicas, if not the most accurate replica, of the original filming model ever created. The included materials from the model's build are enlargements of Simon Atkinson's drawing, a number of vacuum forming patterns used for the fuselage sections, as well as moulds that were for items such as the side door, navigational strobes, and the tail spikes. This lot has had minor airbrushed paint touch-ups. The electronics were designed to run for brief periods only and carry a risk of overheating and potential damage if run for long durations. The patterns and moulds exhibit discolouration from age. Dimensions: 193.25 cm x 91.5 cm x 51 cm (76" x 36" x 20")

Special shipping required; see notice in the Buyer's Guide.

Estimate. £20,000 - 30,000

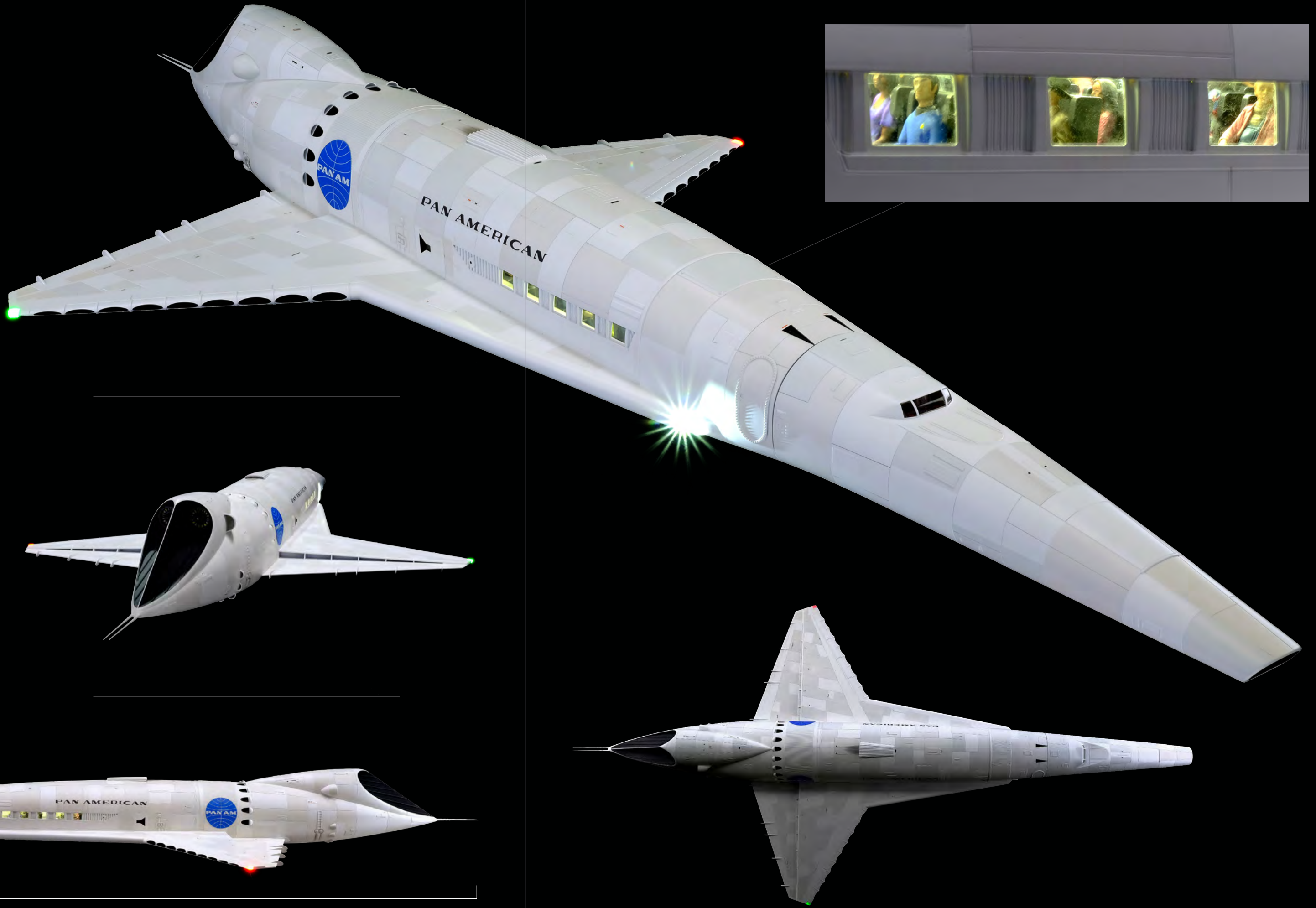

1.93 m (6.3')

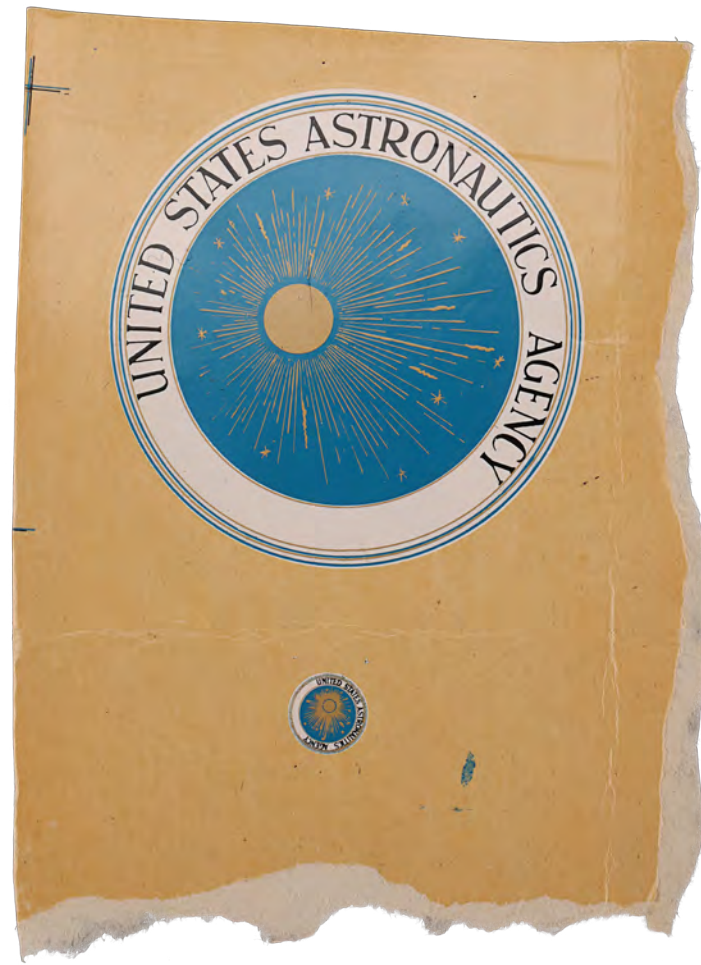

3
USAA Stickers M
2001: A Space Odyssey (1968)

A pair of unused United States Astronautics Agency stickers from Stanley Kubrick's 2001: A Space Odyssey. The USAA logo appeared on spacesuits and equipment used for the Discovery mission.

The two circular stickers – one large and one small – feature the fictitious agency's name around the edge and a gold-coloured sun on a blue background at the centre. The stickers are still adhered to their original paper backing, which has been torn from a larger page of stickers. Dimensions (large sticker): 6 cm x 6 cm (2 1/4" x 2 1/4"); (small sticker): 1.2 cm x 1.2 cm (1/2" x 1/2")

Estimate. £1,500 - 2,500



4
Charlie Prince's (Ben Foster)
Screen-matched Bloodied Costume M
3:10 To Yuma (2007)

Charlie Prince's (Ben Foster) screen-matched bloodied costume from James Mangold's Western 3:10 to Yuma. Sadistic gunslinger Prince wore his costume throughout the film as he attempted to bust out his boss Ben Wade (Russell Crowe). The costume screen-matches the scene in which Wade shoots Prince in the chest through the intentional distressing and markings all over the jacket.

The costume consists of a double-breasted leather jacket and a pair of brown woollen trousers. The lining of the jacket features black tape where a blood squib was previously adhered. Both pieces are heavily distressed with dried mud and stage blood.

Estimate. £4,000 - 6,000



5
Captain's (Vincent Regan)
Spartan "Stage 4" Costume M
300 (2006)

Captain's (Vincent Regan) Spartan "Stage 4" costume from Zack Snyder's historical action film 300. Captain wore his costume throughout the film as he fought alongside Leonidas (Gerard Butler) and the rest of the Spartans against the Persian army.

The costume consists of a fibreglass helmet (labelled "Capt."); a cape ("Captain Stunt Stage 4"); a leather jockstrap ("Captain Stunt"); a pair of resin bracers ("Captain Stage 4"); and a pair of resin greaves ("Captain Stage 4"). The costume has been intentionally distressed to look battle-scarred, with stage blood, cuts and applied dirt and tarnishing. The costume has additional wear from production use, including some damage around the helmet nose piece.

Estimate. £6,000 - 8,000



6
Dilios' (David Wenham) Costume M
300 (2006)

Dilios' (David Wenham) costume from Zack Snyder's historical action film 300. Dilios wore his costume throughout the movie, as he fought alongside King Leonidas (Gerard Butler) and their fellow Spartans against the Persian army.

The costume consists of a rubber helmet with a foam insert (labelled "Dilios"); a cape ("Dilios Stunt Stage 1"); a leather jockstrap (labelled "NA"); a pair of rubber bracers ("106 Dilios Stunt Stage 1" and "4: Dilios Stage 1"); and a pair of rubber greaves ("Dilios" and "Alex Cadieux"). The costume has been intentionally distressed to look battle-scarred, with stage blood, cuts and applied dirt and tarnishing. The costume has additional wear from production use, including slight warping of the helmet.

Estimate. £6,000 - 8,000



7
Reggie Hammond's (Eddie Murphy)
Screen-matched Suit M
48 Hrs (1982)

Reggie Hammond's (Eddie Murphy) screen-matched suit from Walter Hill's crime comedy 48 Hrs. Reggie wore his suit throughout the film, after his release from prison. Through its pattern and placement of the lapel buttonhole, this suit screen-matches the one Reggie wore in several scenes, including the police station scenes and the scene in the nightclub.

The costume consists of a double-breasted Giorgio Armani woollen suit; a white shirt (size "16 1/2"); a brown tie; a black leather belt (labelled "JW2") and a pair of metal cufflinks.

Estimate. £4,000 - 6,000



8
Jimmy "B-Rabbit" Smith's (Eminem)
Screen-matched Costume M
8 Mile (2002)

Jimmy "B-Rabbit" Smith's (Eminem) costume from Curtis Hanson's hip hop drama 8 Mile. Jimmy wore his costume in several scenes, including his dalliance with Alex Latourno (Brittany Murphy) and several rap battles.

The costume comprises a screen-matched Wedgwood blue T-shirt; a thermal long-sleeved Cherokee® top; a pair of blue Phat Farm work jeans; and a blue web belt with a silver-coloured buckle. The costume has been intentionally distressed to appear well-worn and retains a slightly musty odour. It comes with a production tag bearing the word "Jimmy" and listing a scene number in which the outfit was worn. The costume is accompanied by a certificate of authenticity from Universal Pictures.

Estimate. £4,000 - 6,000



9
David Norris' (Matt Damon)
Portal Hat †Δ
Adjustment Bureau, The (2011)

David Norris' (Matt Damon) portal hat from George Nolfi's sci-fi thriller The Adjustment Bureau. David was given the hat by Harry (Anthony Mackie) so he could teleport through doors and evade the Bureau. The grey trilby is made of straw and has "MD" handwritten inside. It is accompanied by a custom-made display stand featuring the film's title.

Estimate. £3,000 - 5,000



10
Elise Sellas' (Emily Blunt)
Screen-matched Black Dress †Δ
Adjustment Bureau, The (2011)

Elise Sellas' (Emily Blunt) screen-matched black dress from George Nolfi's sci-fi thriller The Adjustment Bureau. Elise wore her dress during the film's climax, as she and David Norris (Matt Damon) used doors to teleport around New York City, while avoiding Adjustment Bureau agents. The sheer black fabric dress matches the one seen on-screen through its floral pattern and the stitching around the neckline. It also features a sewn-in bra.

Estimate. £4,000 - 6,000



11
Ripley's (Sigourney Weaver) Hatchet †
Alien (1979)

Ripley's (Sigourney Weaver) hatchet from Ridley Scott's sci-fi horror Alien. White hatchets hung on the wall of the Nostromo shuttle's spacesuit closet, and several publicity photos showed Ripley in her iconic tank top, holding a hatchet while hidden among the spacesuits. The hatchet features a steel head and handle, and exhibits wear from production. Dimensions: 32.5 cm x 2.5 cm x 15.5 cm (12 3/4" x 1" x 6")

Estimate. £5,000 - 7,000



12
Brett's (Harry Dean Stanton) Nostromo Cap 
Alien (1979)

Brett's (Harry Dean Stanton) Nostromo cap from Ridley Scott's sci-fi horror Alien. Brett wore his cap throughout the film, until his untimely demise.

The blue cap has a Nostromo patch, golden-coloured laurels stitched onto the brim and half of the adjustable plastic strap at the rear. The cap has wear from use and age, most notably some staining and faded colours all over. One half of the plastic closure at the back is a replacement. The stitching around the cap has faded over time, changing it from blue to white. It is presented on a padded display stand.

Estimate. £10,000 - 15,000

20th Century Fox/Kobal/Shutterstock

13
Ripley's (Sigourney Weaver)
Stunt/Stand-in Nostromo Jumpsuit 
Alien (1979)

Ripley's stunt/stand-in Nostromo jumpsuit from Ridley Scott's sci-fi horror Alien. Warrant Officer Ellen Ripley wore her jumpsuit for most of the film as she and the rest of the Nostromo crew hunted the alien intruder on board.

The jumpsuit is made from nylon canvas, with long sleeves, multiple zipped pockets, a multi-coloured "USCSS Nostromo" patch on the right sleeve, and a wings patch on the left breast beneath a metal red-and-gold pin. The jumpsuit has "S. Weaver/L. Mitchel No (2)" handwritten on a label inside the collar. Liz Mitchell was Weaver's uncredited stand-in on set.

The jumpsuit has been intentionally distressed, with stains and markings to appear well-worn. The green T-shirt and white sneakers are not original and have been added to complete the costume.

Estimate. £20,000 - 30,000





14
 Charles Lippincott Collection:
 Production-Used Bob Penn and
 Barry Payne Printed Contact Sheets
 with Modern Colour Photos Ω
Alien (1979)

A collection of production-used Bob Penn and Barry Payne printed contact sheets with modern colour photos from Ridley Scott's sci-fi horror film Alien.

This lot comes from the collection of Charles "Charley" Lippincott. It consists of a paper folder containing printed black-and-white contact sheets, and a black binder with 20.5 cm x 25.5 cm colour photographs from the production. The folder features a "Charles D492" mark on the cover and pink highlighted sheets. The binder features an "Outtakes Color 1" label on the spine. This lot exhibits some tearing, creasing, and poor legibility due to photocopy quality.

Dimensions: 45.75 cm x 30.5 cm x 5.25 cm
 (18" x 12" x 2")

Estimate. £1,500 - 2,500



16
 No Lot



15
 Xenomorph Egg Miniature
 with Base M
Aliens (1986)

A xenomorph egg with a base from James Cameron's sci-fi action sequel Aliens. Eggs were seen in the nest of the Alien Queen when Ripley (Sigourney Weaver) arrived there to rescue Newt (Carrie Henn).

This egg would have been used for miniature sets of the Queen's nest. Both the egg and its base are made of hand-painted fibreglass. The egg slots into the centre of the base, which features a veiny, organic design. Some of the base's tendrils have broken off. Dimensions (egg on base): 27 cm x 27 cm x 33 cm (10 1/2" x 10 1/2" x 13")

Estimate. £6,000 - 8,000

17
"Bug Stomper"/"Smart Ass"
Dropship Model Miniature M
Aliens (1986)

Update: This model was previously photographed without the front missile pods present; the front pods have since been located and installed and are included with the model. The photo set has been updated to show the included front pods.

A "Bug Stomper"/"Smart Ass" dropship model miniature from James Cameron's sci-fi action sequel Aliens. Ellen Ripley (Sigourney Weaver) and an elite team of Colonial Marines used a dropship named "Bug Stomper" to land on the surface of LV-426, but it later crash-landed during an attempted evacuation. Bishop (Lance Henriksen) remotely operated the second dropship - named "Smart Ass" - to rescue himself, Ripley, Newt (Carrie Henn) and Hicks (Michael Biehn).

The UD-4L class dropship, commonly known as the "Cheyenne", was designed by Cameron in collaboration with legendary artist Ron Cobb and was loosely based on an Apache attack helicopter, as well as other Vietnam War-era aircraft, in keeping with the film's Vietnam War undertones.

Several dropship models were made for the production for different purposes, and to different scales. This dropship features both "01" and "02" decals, one on each side, indicating that it was used as both "Bug Stomper" and "Smart Ass" during filming. The cockpit features the "Smart Ass" decals on both sides, and white text below the windows reads "Corporal Ferro/PFC Spunkmeyer". Inside the cockpit are two miniature pilots dressed in military gear.

The model is primarily made of fibreglass over a metal skeleton, with resin and styrene detailing. The front two landing pads are high-quality reproductions. The wings and rear missile pods are mounted on hinges and can be folded out, and the dropship has been intentionally distressed to appear well-used in battle. Sections of the dropship, including the wings, have undergone restoration. It has some additional scuffs and scratches, some of the decals are peeling away, there is a hole intentionally cut into the top, and the missile pods on either side of the cockpit are no longer present. It is displayed on a custom-built metal stand. Dimensions (wings open): 205 cm x 122.5 cm x 63 cm (80 3/4" x 48 1/4" x 24 3/4")

Contains electronics; see electronics notice in the Buyer's Guide.

Special shipping required; see special shipping notice in the Buyer's Guide.

Estimate. £100,000 - 150,000

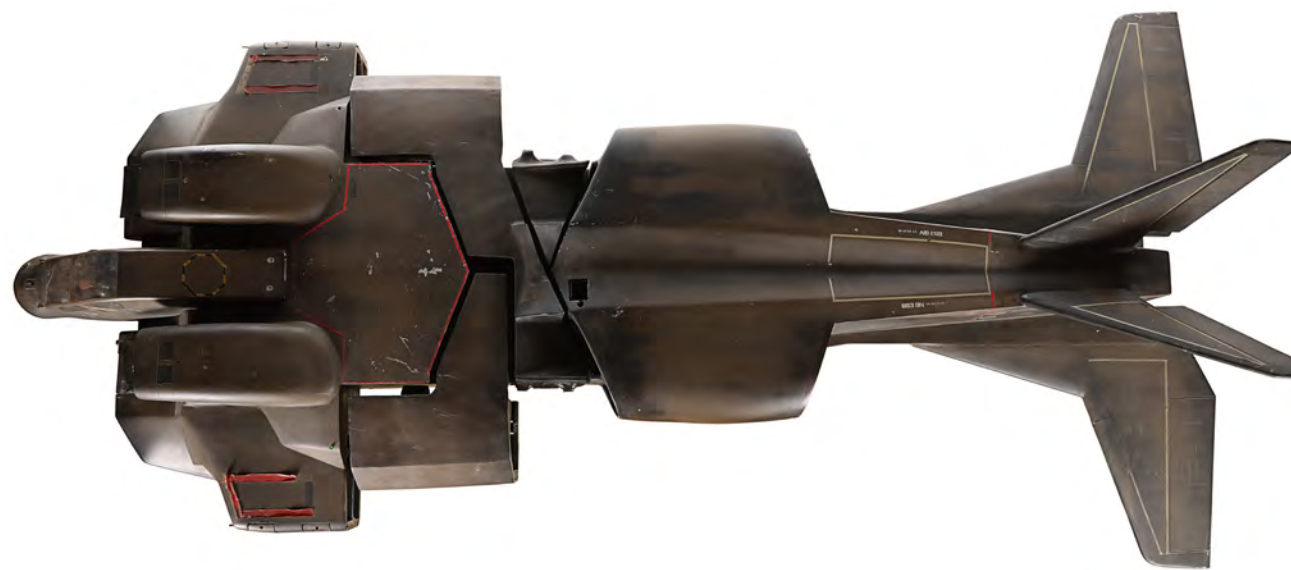



18
Hero Pulse Rifle †
Aliens (1986) & Alien 3 (1992)

A hero pulse rifle from David Fincher's sci-fi sequel Alien 3. Weyland-Yutani soldiers under the command of Bishop II (Lance Henriksen) carried pulse rifles when they arrived at the end of the film and attempted to take Ripley (Sigourney Weaver) with them. Pulse rifles first appeared in James Cameron's Aliens, carried by the Colonial Marines and later used by Ripley. After Aliens wrapped the rifles were broken down to their core guns and the dressing components were kept. They were then rebuilt for the production of Alien 3 using the different components, although new shrouds were made from vacuum-formed plastic based on an original Aliens metal one. The weapon is built around a Thompson sub-machine gun, which has been sympathetically deactivated. It also features an imitation shotgun made from plastic tubing.

The weapon is painted black, although there is a small section missing at the rear of the shroud which is green, as they were in Aliens.

The weapon is accompanied by a certificate of deactivation and comes in a protective, wheeled carrying case. The plastic shroud has some paint wear and remains in a slightly fragile state. Dimensions: 67 cm x 7 cm x 25 cm (26 1/2" x 2 3/4" x 9 3/4")

Firearm deactivated; see firearm deactivation notice in the Buyer's Guide.

Restricted ownership; see replica firearm notice in the Buyer's Guide.

Special shipping required; see special shipping notice in the Buyer's Guide.

Estimate. £60,000 - 100,000





LANDMARK MEDIA / Alamy Stock Photo



19
Corporal Dwayne Hicks' (Michael Biehn) Hero Shotgun us
Aliens (1986)

Corporal Dwayne Hicks' (Michael Biehn) hero shotgun from James Cameron's sci-fi sequel Aliens. Hicks wielded his shotgun during the Colonial Marines' first confrontation with the xenomorphs, culminating in his blasting the head off the xenomorph that blocked the door of their Armoured Personnel Carrier (APC), keeping it from closing.

This 12-gauge Ithaca 37 has been sympathetically deactivated as confirmed by a Deactivation Certificate issued by the Birmingham Gun Barrel Proof House. It features a metal body with a custom cut-down barrel and hunting scenes engraved on the sides; an etched wooden forearm; ridged Bakelite plating around the custom-modified MP-40 pistol grip and trigger guard; and a hole through the back for attaching a folding stock.

Black tape on the grip is no longer present, and the shotgun exhibits scuffing to the wood and nicks throughout the metal from production use. As this lot ships from Los Angeles, shipping should be arranged with Propstore prior to bidding. Dimensions: 58.5 cm x 5.25 cm x 18 cm (23" x 2" x 7")

Firearm deactivated; see firearm deactivation notice in the Buyer's Guide.

Special shipping required; see notice in the Buyer's Guide.

Estimate. £40,000 - 60,000

20
Sergeant Apone's (Al Matthews)
Screen-Matched USCM Armour Ω
Aliens (1986)

Sergeant Apone's (Al Matthews) screen-matched USCM armour costume from James Cameron's sci-fi sequel Aliens. Apone and his fellow U.S. Colonial Marines helped Ellen Ripley (Sigourney Weaver) investigate the battle-ravaged moon LV-426.

Designed by Emma Porteous and constructed by master armourer Terry English, this set consists of a mixture of screen-matched body armour, additional original components from different characters in the film, and replica components added to complete the costume.

Assembled and hand-formed in aluminium, the camouflage-patterned, foam-padded chest, back, and shoulder plate armour specifically match to shots of the marines preparing to load into the A.P.C. vehicle. "APONE" is stencilled on the upper chest and the interior is marked "APONE No1."

Also included are an abdominal guard composed of original aluminium plates with a replica soft vinyl pad patterned from an original; a pair of aluminium shin guards marked for "BILL PAXTON" with replica kneecaps created by English; an original pair of USCM pants; and a pair of replica boots. The jacket is labelled "FROST" and applied with custom USCM, Sulaco, and American flag patches. The helmet is a replica also created by English after production and labelled "FROST." Additionally, the grenade straps on the front are replicas.

This costume exhibits sections of heavy paint wear on the armour, crumbling foam from age, and various scuffs and scratches from production wear.

Estimate. £60,000 - 100,000

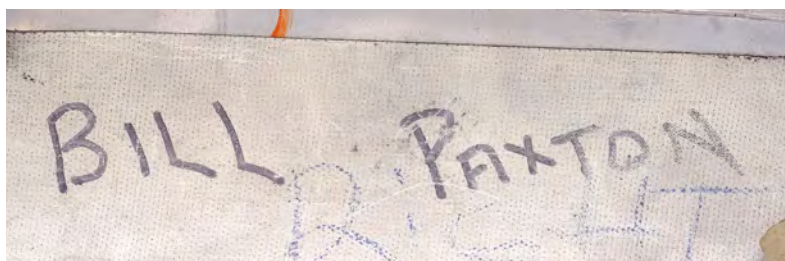

HARRY HARRIS ALIENS COLLECTION & ARCHIVE

The following 11 lots are from the The Harry Harris Aliens Collection and Archive, one of the largest collections of costumes, props and production material from 'Aliens' (1986). The collection has been extensively featured in magazines and on television and Harris was a key contributor to the 'Alien Quadrilogy' DVD set, and a Creative Consultant on the award-winning 'Alien Anthology' Blu-Ray set. The Harris Collection has also worked closely with several 20th Century Fox licensees to bring fresh and new Alien themed products to market.

21 Harry Harris Collection: Pvt. Hudson's (Bill Paxton) USCM Costume m Aliens (1986)

Pvt. Hudson's (Bill Paxton) USCM costume from James Cameron's sci-fi sequel Aliens. Colonial Marine Hudson wore his armour and uniform during the mission on the alien-infested planet of LV-426.

The costume consists of a helmet; body armour; a pair of greaves; a camouflage shirt; a pair of camouflage trousers; prototype webbing; and a pair of leather boots. The armour was made by legendary British armorer Terry English and is marked internally with "Hudson No 1" in black marker pen. "Bill Paxton", "Bill" and "BP" are also handwritten in different areas. The helmet is marked "Hudson" inside, with "Apone" crossed out. The greaves are marked "Paxton" and "L" and "R". The groin pad is marked "Tipping" (Tip Tipping played fellow Marine Pvt. Crowe).

The shirt features Hudson's name patch on the right breast and the trousers and belt are both labelled "Apone". The armour has been intentionally distressed to look well-used and battle-scarred.

Estimate. £40,000 - 60,000



LANDMARK MEDIA / Alamy Stock Photo



Shutterstock





22
 Harry Harris Collection:
 Bishop's (Lance Henriksen)
 Screen-matched Jumpsuit M
Aliens (1986)

Bishop's (Lance Henriksen) screen-matched jumpsuit from James Cameron's sci-fi sequel Aliens. The android Bishop wore his jumpsuit throughout the film and, through stitching on the left lapel and around the shoulders, it screen-matches the scene in which he plays the knife game using Hudson's (Bill Paxton) hand.

The blue jumpsuit has a zip running up the front and multiple zipped pockets along the legs and chest. A USS Sulaco patch is adhered to the right arm and a black belt loops around the waist. The jumpsuit is slightly faded and has some minor staining in places.

Estimate. £6,000 - 8,000



23
 Harry Harris Collection:
 Pvt. Drake's (Mark Rolston)
 Flak Jacket and Fatigues M
Aliens (1986)

Pvt. Drake's (Mark Rolston) flak jacket and fatigues from James Cameron's sci-fi sequel Aliens. Colonial Marine Drake wore his jacket and fatigues during the mission on the alien-infested planet of LV-426. Flak jackets are padded and weighted with materials to protect the wearer from shrapnel and other lower-velocity projectiles.

The green jacket features Drake's name and USCM patches on the right chest, with US flag and USCM patches on the left chest. The jacket zips up the front. It is marked size "medium".

The fatigues consist of a sleeveless top (size "L"), which says "I've served my time in Hell..." CETII EPSILON IV" on the front, and a pair of camouflaged trousers with "34 Mark" handwritten on the label. The top has minor staining on the front and the trouser pattern is slightly faded.

Estimate. £8,000 - 12,000





24
 Harry Harris Collection:
 Pvt. Drake's (Mark Rolston)
 Screen-matched Headset M
Aliens (1986)

Private Drake's (Mark Rolston) screen-matched headset from James Cameron's sci-fi sequel Aliens. Drake wore his headset while on the mission on LV-426.

The headset comprises a mounted camera, a microphone and a sight. The sight screen-matches the one seen on screen through the hand-painted eyeball decoration on its back in the scenes where the Marines prepare for the mission and in the dropship. The three pieces slot together and the sight pivots around a joint. The set has some wear from production use and age: some detailing has come off and there is a small crack along the side of the sight, while the foam padding has melted away around the eyepiece and left hardened black residue.

Contains electronics; see electronics notice in the Buyer's Guide.

Estimate. £15,000 - 25,000



25
 Harry Harris Collection:
 Pvt. Drake's (Mark Rolston)
 Dog Tag M
Aliens (1986)

Pvt. Drake's (Mark Rolston) dog tag from James Cameron's sci-fi sequel Aliens. Drake wore his dog tags as part of his Colonial Marine uniform. The clear acrylic tag is looped onto a metal chain, and has Drake's name and serial number engraved on it. Dimensions: 3.8 cm x 4.5 cm (1 1/4" x 1 1/2")

Estimate. £3,000 - 5,000



26
 Harry Harris Collection:
 Lt. Gorman's (William Hope)
 Screen-matched USCM Shirt M
Aliens (1986)

Lt. Gorman's (William Hope) screen-matched USCM shirt from James Cameron's sci-fi sequel Aliens. Gorman wore his shirt for much of the film, while commanding the Colonial Marines on the xenomorph-infested planet LV-426. The shirt matches the one seen on-screen during the mission briefing through a notable crease on the left sleeve, the lettering on the name patch, and the name-patch stitching.

The green shirt buttons up the front and features Gorman's name patch, USCM patch and USS Sulaco patch on the chest; a USCM patch on the right sleeve; and an American flag on the left sleeve. Some of the patches feature wear and slight fading.

Estimate. £3,000 - 5,000



27
 Harry Harris Collection:
 Lt. Gorman's (William Hope)
 Dress Uniform M
Aliens (1986)

Lt. Gorman's (William Hope) dress uniform from James Cameron's sci-fi sequel Aliens. Colonial Marine Gorman wore his dress uniform when he visited Ripley's (Sigourney Weaver) apartment with Company man Carter Burke (Paul Reiser) to convince her to join the mission to alien-infested planet LV-426.

The uniform comprises a khaki shirt; a green pair of trousers; a leather belt; and a green peaked cap. The shirt features Gorman's name patch, USCM patch and USS Sulaco patch on the chest; a USCM patch on the right sleeve; and an American flag on the left sleeve.

Estimate. £4,000 - 6,000



28
 Harry Harris Collection: USCM Shoulder Torch Pack M
Aliens (1986)

A USCM shoulder torch pack from James Cameron's sci-fi sequel Aliens. Colonial Marines wore shoulder-mounted torches, which they could unclip and carry by hand.

The lot consists of the torch with a handle; a green canvas pouch with "AR" handwritten on the back; a lanyard; and a short power pack, with a UK mains plug. "50-105 VA" is handwritten on the power pack. The lot has some wear to the paintwork. Please note that the canvas pouch and power pack are not film-used originals. Dimensions (torch): 23 cm x 19 cm x 32 cm (8 3/4" x 7 1/2" x 12 1/2")

Contains electronics; see electronics notice in the Buyer's Guide.

Estimate. £10,000 - 15,000



29
Harry Harris Collection:
Cpl. Ferro's (Colette Hiller) Jumpsuit M
Aliens (1986)

Corporal Ferro's (Colette Hiller) jumpsuit from James Cameron's sci-fi sequel Aliens. Ferro wore her jumpsuit on the Colonial Marines' mission to the xenomorph-infested planet LV-426. The green jumpsuit has a zip down the front and zipped pockets on the chest and legs. There are name and "Victory by Wings" patches on the chest; an American flag and rank patch on the left arm; and a USCM patch on the right arm. A label inside the collar reads "3". There are some small areas of staining and discolouration on the jumpsuit.

Estimate. £4,000 - 6,000



30
Harry Harris Collection:
Pvt. Spunkmeyer's (Daniel Kash) Jumpsuit M
Aliens (1986)

Private Spunkmeyer's (Daniel Kash) jumpsuit from James Cameron's sci-fi sequel Aliens. Colonial Marine Spunkmeyer wore his jumpsuit on the mission to xenomorph-infested planet LV-426. The green jumpsuit has a zip down the front and zipped pockets on the chest and legs. There are name and "Victory by Wings" patches on the chest; an American flag and rank patch on the left arm; and a USCM patch on the right arm. A label inside the collar reads "6". The left lapel is loose and a seam has split on the left shoulder.

Estimate. £4,000 - 6,000



31
Harry Harris Collection:
Pair of Xenomorph Warrior Feet M
Aliens (1986)

A pair of xenomorph warrior feet from James Cameron's sci-fi sequel Aliens. These rubber feet were made for performers playing the aliens. They are hand-painted and feature zips down the back for ease of access. The rubber has cracked slightly in some places.

Estimate. £4,000 - 6,000



32
VP70M Sidearm Pistol US
Aliens (1986)

A VP70M sidearm pistol from James Cameron's sci-fi sequel Aliens. The Colonial Marines, including Pvt. Frost (Ricco Ross) and Lt. Gorman (William Hope), wielded Heckler & Koch VP70Ms when they investigated the disappearance of the colonists on LV-426 with Ellen Ripley (Sigourney Weaver).

Cameron and armourer Simon Atherton selected the VP70 as the signature USCM sidearm due to its futuristic design, relative obscurity, and affordability. This semi-automatic, three-round burst fire pistol was sympathetically deactivated following production, but retains its full cocking and moving action and a removable magazine. It is stamped "Mod VP'70 9MM x 19" on the side and comes with a brown, red-fleece lined case labelled "M.A.M."

The pistol exhibits scratching and scuffs on the metal from production use, and the case exhibits staining and peeling. As this lot ships from Los Angeles, shipping should be arranged with Propstore prior to bidding. Dimensions: 21.75 cm x 4 cm x 14 cm (8.5" x 1.5" x 5.5")

Firearm deactivated; see firearm deactivation notice in the Buyer's Guide.

Special shipping required; see notice in the Buyer's Guide.

Estimate. £6,000 - 8,000



33
Screen-Matched Hadley's Hope
Dump Truck Model Miniature Ω
Aliens (1986)

A screen-matched Hadley's Hope dump truck model miniature from James Cameron's sci-fi sequel Aliens. Production constructed model dump trucks for the miniature Hadley's Hope set.

This custom-made miniature is constructed from wood, resin, and vacuum-formed plastic, hand-painted and airbrushed with decals reading "5" and "A.I.D.S.". Its top and bottom components are secured with metal piping and a wood dowel, with the top component designed to "dump" by inserting a puppeteering rod up through the bottom. This miniature is missing a number of components, such as its tracks; large pieces off the back; and the top and front of the model. It also exhibits paint peeling and scuffing. Dimensions: 91.5 cm x 51 cm x 51 cm (36" x 20" x 20")

Estimate. £4,000 - 6,000

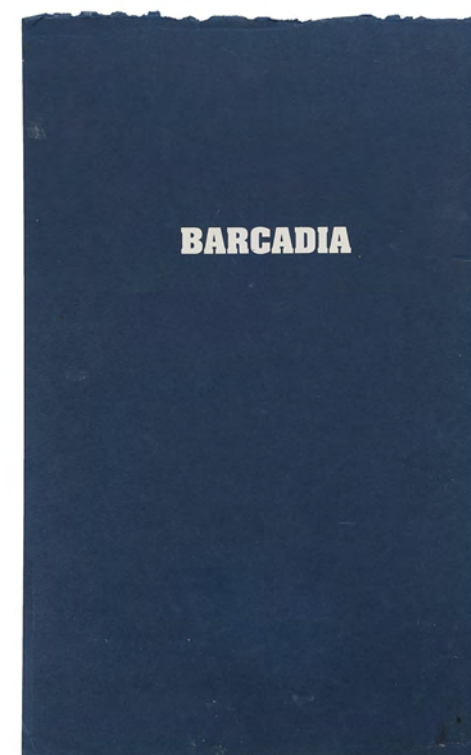

35
Barcadia Menu M
American Psycho (2002)

A Barcadia menu from Mary Harron's satirical crime thriller American Psycho. Patrick Bateman (Christian Bale) took a semi-conscious Courtney Rawlinson (Samantha Mathis) out on a date, having convinced her by pretending Dorsia restaurant. On arriving at the far less impressive Barcadia, he continued the ruse, despite holding up a menu that very clearly read "Barcadia".

The menu is made of thick navy blue card, and features white block lettering. On the interior is a white piece of card with a series of courses printed in a similar navy blue. The menu shows a tear along the top edge and one on the right, and there are scuffs and smudges throughout. Dimensions: 41 cm x 25.5 cm (16" x 10")

Estimate. £2,000 - 3,000



34
Business Cards Display M
American Psycho (2002)

A set of business cards from Mary Harron's satirical crime thriller American Psycho. Patrick Bateman (Christian Bale) and his colleagues competitively compared their business cards during a meeting at their company Pierce & Pierce. Bateman's seething anger at having his card bested by that of his colleague Paul Allen (Jared Leto) - despite the two cards looking almost identical - satirised the vacuous materialism of 1980s yuppie culture.

The set comprises six embossed business cards featuring a variety of fonts. Each card exhibits the character's name and job title, together with the Pierce & Pierce logo, phone number and address.

The business cards are presented in a display with a carved Whistler-style wooden frame featuring a laser-cut backboard and an acrylic display pane. Each card is placed in a clear plastic mount that is screwed into the backboard. The display includes two stills from the scene in which the cards feature. Also included is a portrait of a knife-wielding Bateman taken from the film's poster. A picture of Bateman's card appears adjacent to the words "...no introduction necessary". At the bottom of the display are the words "An original set of Pierce & Pierce business cards used in AMERICAN PSYCHO". There are scratches and small holes in the wooden frame.

Dimensions (each card): 62 cm x 43 cm x 4 cm (24 1/2" x 17" x 1 1/2")

Estimate. £6,000 - 8,000



36
Screen-matched "Transformation"
Clapperboard M
American Werewolf in London, An
(1981)

A clapperboard from the production of the iconic and groundbreaking transformation scene in John Landis' horror-comedy An American Werewolf in London. This wooden clapperboard screen-matches one seen in behind-the-scenes footage during the filming of the werewolf transformation through its lettering and wear.

The clapperboard features the film's title, director Landis' and cinematographer Robert Paynter's names, and sections for the slate and take numbers. The names are presented with raised stickers, and the "a" and "i" from Landis' name are missing. The bottom of the board features several strips of tape stuck on top of each other, with "10.4.81 Night/Int." handwritten in black ink on the most recent strip. The back of the clapperboard features pieces of tape which read "A Cam", "S" and "Dusk/Int". Dimensions: 15 cm x 27 cm x 20.5 cm (1/2" x 10 3/4" x 8")

Estimate. £6,000 - 8,000



37
SFX Undead Jack Goodman's (Griffin Dunne)
Prosthetic Hand M
American Werewolf In London, An (1981)

A prosthetic hand used to depict the decaying left hand of Jack Goodman (Griffin Dunne) in John Landis' horror comedy An American Werewolf in London. The hand appeared in two scenes where an undead, decaying Goodman visited his friend David Kessler (David Naughton) to persuade him to kill himself in order to avoid turning into a werewolf. Kessler noticeably looks down at the hand in alarm during one such conversation.

Designed by prosthetics supremo Rick Baker, the hand is made of foam latex with intricate detailing to depict knuckles and metacarpals. The skin is presented as wrinkled and putrefied. Baker won the first-ever Academy Award® for Best Make-up for his work on the film. The item comes with a certificate of authenticity from Joseph Ross, who was part of Baker's Special Make-up Effects crew. Ross also acted as a hand double for Dunne, wearing the prosthetic hand in the Piccadilly Circus cinema sequence.

Dimensions: 29 cm x 18 cm (11 1/2" x 7")

Estimate. £6,000 - 8,000



38
Light-up Armadillo
Model Miniature Ω
Armageddon (1998)

A light-up Armadillo model miniature from Michael Bay's sci-fi adventure Armageddon. The crews of the Independence and Freedom used their Armadillos to travel the asteroid's surface. Shots on the asteroid were achieved with a combination of live-action photography and model miniature work.

Created by effects company Dream Quest Images, this miniature, 12-wheeled vehicle with detailed panelling across the cab and a top-mounted drilling arm is constructed from resin finished in silver-colour paint. The underside is mounted with wiring designed to illuminate small LED lights around the cab via a AA battery pack, which is also included. The model exhibits scuffed paint throughout and a missing light from production. Dimensions: 9 cm x 5.5 cm x 10.25 cm (3.5" x 2.25" x 4")

Contains electronic components; see notice in the Buyer's Guide.

Estimate. £4,000 - 6,000



39
SFX Necronomicon M
Ash Vs Evil Dead (T.V. Series, 2015-2018)

An SFX Necronomicon from the horror-comedy TV series Ash vs Evil Dead. The iconic Necronomicon first appeared in Sam Raimi's 1981 horror The Evil Dead, and was used in the series by Ash (Bruce Campbell) to accidentally summon the Kandarian Demon. This SFX version was used for scenes in which something went into, or came out of, the mouth which forms part of the book's cover.

The book is made of resin and wood, with a silicone cover painted to look like ancient leathery flesh. The back of the book is open, allowing the performer to push their hand through the mouth. The silicone cover has a sticky sheen and there is some wear to the paintwork. Dimensions: 29 cm x 23 cm x 4.5 cm (11 1/2" x 5" x 1 3/4")

Estimate. £10,000 - 15,000



40
Kandarian Dagger M
Ash Vs Evil Dead
(T.V. Series, 2015-2018)

A Kandarian Dagger from the horror-comedy TV series Ash vs Evil Dead. The Kandarian Dagger first appeared in Sam Raimi's 1981 horror The Evil Dead and was used in the series by Ruby Knowby (Lucy Lawless) to cut the skin binding off the Necronomicon, while Ash (Bruce Campbell) later taped it to his "boomstick" as a bayonet. He also used it to fight Kandar the Destroyer in the third season finale "The Mettle of Man".

The dagger is made of resin, painted to look like a metal blade and an ancient bone handle, which is shaped like a demonic snake. The blade has some small nicks along its length and the handle has a couple of spots of stage blood. Dimensions: 44 cm x 5.5 cm x 6 cm (17 1/4" x 2 1/4" x 2 1/4")

Estimate. £4,000 - 6,000



41
 Austin Powers' (Mike Myers)
 Blue Suit M
**Austin Powers: International Man
 Of Mystery (1997)**

Austin Powers' (Mike Myers) blue suit from Jay Roach's spy comedy Austin Powers: International Man of Mystery. Austin wore his blue suit near the beginning of the film as he and Mrs. Kensington (Mimi Rogers) infiltrated a party to track down Dr. Evil (Mike Myers).

The suit comprises a blue velvet jacket with a green swirl-patterned silk lining and plastic buttons; a pair of blue velvet trousers with a metal zip; and a white cotton ruffle-collared shirt (size M) with plastic buttons and a detachable cravat. The jacket features "Mike Myers" handwritten in both inside pockets.

Estimate. £30,000 - 50,000



Photo 12 / Alamy Stock Photo



Album / Alamy Stock Photo



42
 Dr. Evil's (Mike Myers) Chair us
Austin Powers: International Man Of Mystery (1997)

Dr. Evil's (Mike Myers) chair from Jay Roach's spy comedy Austin Powers: International Man of Mystery. Dr. Evil rose from his signature chair to demand \$100 billion from the U.N.

Designed to mimic the chairs of classic James Bond villains, this chair - a production-built replica of a vintage Hans J. Wegner AP-46 Ox model - originated with a crew member. It features a padded black leather body with a hammerhead-style headrest and a tubular steel frame. The padding exhibits scuffing, white staining, and scratches from production use. Dimensions: 99 cm x 81.5 cm x 86.5 cm (39" x 32" x 34")

Special shipping required; see notice in the Buyer's Guide.

Estimate. £3,000 - 5,000

43
 Dr. Evil (Mike Myers)
 and Mini-Me's (Verne Troyer) Rings Ω
Austin Powers: The Spy Who Shagged Me (1999)

Dr. Evil (Mike Myers) and Mini-Me's (Verne Troyer) rings from Jay Roach's spy comedy sequel Austin Powers: The Spy Who Shagged Me. Dr. Evil and his diminutive clone wore matching rings on their right-hand little fingers.

Each metal ring features Dr. Evil's angular "E" logo and comes with a ring box. Mini-Me's ring box has "Mini Me" handwritten on tape on the underside. Dimensions (largest ring): 2.5 cm x 2.3 cm x 2.3 cm (1" x 1" x 1")

Estimate. £4,000 - 6,000



44
 Austin Powers' (Mike Myers)
 Glasses Ω
**Austin Powers: The Spy
 Who Shagged Me (1999)**

Austin Powers' (Mike Myers) glasses from Jay Roach's spy comedy sequel Austin Powers: The Spy Who Shagged Me. Austin wore his glasses throughout the film, as he returned to 1969 to retrieve his mojo from Dr. Evil (Mike Myers).

These Paul Smith glasses comprise a thick black frame, a thick bridge across the nose, and low prescription lenses. The inside of the frame is coloured red, and one arm displays the Paul Smith logo. The glasses are presented in a black leather case lined in dark green velvet. A label reading "Austin" is adhered to the lid, and an additional piece of tape features the text "Austin Glasses Stunt". Dimensions (glasses): 15 cm x 15 cm x 4.5 cm (6" x 6" x 1 3/4"); (case): 15.5 cm x 6 cm x 2.5 cm (6" x 2 1/4" x 1")

Estimate. £4,000 - 6,000





45
Austin Powers' (Mike Myers)
Blue-velvet Stunt-harness Suit +
Austin Powers In Goldmember (2002)

Austin Powers' (Mike Myers) blue-velvet stunt-harness suit from Jay Roach's spy-comedy sequel Austin Powers in Goldmember. The opening credits sequence shows the film Austinpussey being made by director Steven Spielberg, with Tom Cruise starring as Austin Powers, wearing his signature blue velvet suit. This particular version of the suit was created for the stunt sequence where Austin (Cruise) ejected himself from his Shaguar car and jumped over a helicopter.

The costume comprises a blue-velvet jacket and matching trousers, a white high-necked frilly shirt, and a metal male-symbol pendant. "Flip Dummy" is handwritten inside the right interior jacket pocket, and the sides of the jacket have two intentional slits allowing for the use of a harness. A label with handwritten text reading "Mike Harness" is adhered to the inside of the trousers' waistband. There are signs of fraying on the lining of the slits.

Estimate. £8,000 - 12,000



46
Austin Powers' (Mike Myers) Hero Medallion +
Austin Powers In Goldmember (2002)

Austin Powers' (Mike Myers) medallion from Jay Roach's spy comedy Austin Powers in Goldmember. Austin wore his medallion accessory, which he received at school when winning the title of "International Man of Mystery", throughout the film.

The silver-tone metal medallion comprises a male symbol charm linked to a ball chain. Dimensions: 47.5 cm x 5.5 cm x 1 cm (18 3/4" x 2 1/4" x 1/2")

Estimate. £4,000 - 6,000



47
2nd Unit Clapperboard +
Avengers: Age Of Ultron (2015)

A clapperboard from the production of Joss Whedon's superhero sequel Avengers: Age of Ultron.

Used by the film's second camera crew unit during filming, the clapperboard consists of an acrylic slate with a wooden clapper fixed to the top. The slate features the working title "Afterparty" and the names of the 2nd unit director John Mahaffie and the 2nd unit director of photography John Gamble, all engraved in black. Outlined boxes divide the piece into fields titled scene, take, date and roll number, all of which contain remnants of handwritten details in black marker pen. There are signs of scuffing along the clapper arm and rear section of the board, with some scratches on the acrylic slate. Dimensions: 3.5 cm x 28 cm x 23.5 cm (1 1/4" x 11" x 9 1/4")

Estimate. £3,000 - 5,000



48
Pair of Black Widow's (Scarlett Johansson) Live-fire Glock 26s +
Avengers: Age Of Ultron (2015)

Black Widow's (Scarlett Johansson) live-fire Glock 26s from Joss Whedon's superhero sequel Avengers: Age of Ultron. Black Widow used her Glock 26s to fight Ultron (James Spader) and his murderous robots during the climactic battle in Sokovia.

The firearms are polymer-framed Glock 26s chambered for 9mm and with a magazine capacity of 10. They were used for the UK portion of filming and fired blanks. One is a slightly earlier generation model of the 26. During production, the takedown latches twisted slightly in the frame, and as such they were taken out of service after the production wrapped. Both weapons are categorised as Section 5 under UK law and are not currently deactivated. Dimensions (each): 16.5 cm x 3 cm x 10.5 cm (6 1/2" x 1 1/4" x 4")

Live firearm stored in the UK; see the UK live firearm notice in the Buyer's Guide.

Estimate. £6,000 - 8,000



PictureLux / The Hollywood Archive / Alamy Stock Photo



49
 Captain America's (Chris Evans) Chest Emblem †Δ
Avengers: Age Of Ultron (2015)

Captain America's (Chris Evans) chest emblem from Joss Whedon's superhero sequel Avengers: Age of Ultron. Captain America's uniform featured a star-shaped emblem at the centre of its chest.

The emblem is made of metal-powdered resin. It features several poppers at the back to attach it to the uniform, though one of the poppers is missing. The emblem is displayed on a custom-made stand. Dimensions: 12 cm x 12 cm x 1 cm (4 3/4" x 4 3/4" x 1/2")

Estimate. £3,000 - 5,000



50
 Vision's (Paul Bettany) Chest Emblem †Δ
Avengers: Age Of Ultron (2015)

Vision's (Paul Bettany) chest emblem from Joss Whedon's superhero sequel Avengers: Age of Ultron. Vision wore his emblem on his chest after being created by the Avengers using the Mind Stone. The brass emblem is labelled "2" in black ink on the back, alongside a hook which attached it to the costume. It is displayed on a custom-made stand. Dimensions: 8 cm x 6.5 cm x 1 cm (3 1/4" x 2 1/2" x 1/2")

Estimate. £1,500 - 2,500



51
 DeLorean "OUTATIME"
 Licence Plate Ω
Back To The Future (1985)

A DeLorean "OUTATIME" licence plate from Robert Zemeckis' sci-fi adventure Back to the Future. The DeLorean's licence plate fell off of the back of the vehicle during the first temporal experiment in the Twin Pines Mall parking lot.

Designed to emulate the look of real period-specific licence plates, this metal California licence plate is affixed with stickers numbered "52654" and dated "Aug" and "86." "OUTATIME" stands out in relief on the front, and it features four holes for mounting to a vehicle. The plate exhibits chips around its edges, exposing the metal. Dimensions: 30 cm x 15 cm x 0.75 cm (12" x 6" x 0.25")

Estimate. £8,000 - 12,000



52
 Official Licensed (2011) Light-Up
 Size 11 Marty McFly (Michael J. Fox)
 Nike MAG Shoes Ω
Back To The Future Part II (1989)

Official, licensed light-up size 11 Marty McFly (Michael J. Fox) Nike MAG shoes as seen in Robert Zemeckis' sci-fi sequel Back to the Future Part II. Doc Brown (Christopher Lloyd) gave Marty self-lacing shoes when they time-travelled to 2015 Hill Valley.

Designed by Nike shoe veteran Tinker Hatfield, Marty McFly's Nike MAG Shoes are one of the most recognizable Nikes ever made. In 2011, Nike released these licensed, high-top sneaker replicas to benefit Michael J. Fox's Foundation for Parkinson's Research. The shoes were only available through auction and were highly sought after.

This pair is a rare US size 11. They feature soft grey canvas panels with the Nike swoosh on the side, blue-flecked foam spelling "NIKE MAG" affixed to the heel, and a foam midsole. Both are outfitted with LED lights and an illuminating "NIKE" logo on the ankle strap. Also included are the original neon-yellow shipping box labelled "Magnetic Anti Gravity" and signed by Nike staff members, as well as a charger, instruction pamphlet, compact disc, and a miniature DeLorean licence plate. The box exhibits a cut on the top and the foam inside the shoes is lifting from wear. Dimensions: 30.5 cm x 11.5 cm x 26.7 cm (12" x 4.5" x 10.5")

Contains electronic components; see notice in the Buyer's Guide.

Estimate. £10,000 - 15,000



53
 Marty McFly's (Michael J. Fox) Hoverboard Ω
Back To The Future Part II (1989)/Back To The Future Part III (1990)

Marty McFly's (Michael J. Fox) hoverboard from Robert Zemeckis' sci-fi film Back to the Future: Part II and its sequel, Part III. McFly first obtained his hoverboard from a young girl in the year 2015 to escape from Griff Tannen (Thomas F. Wilson) and his gang, and continued to use it throughout both films. The hoverboard became McFly's signature and remains among the most beloved hi-tech innovations associated with the franchise.

Two primary styles of hoverboards were made for production: wood boards for effects work, including shots of the actor riding the board, and lightweight foam boards typically used for shots of the performer carrying the board. This hoverboard - a rare complete and "fresh-to-market" example originating with a production team member - is constructed primarily of rigid lightweight foam, painted pink, and given a photo-print finish on the top and bottom (as opposed to the lenticular print used on some boards).

The top features the word "HOVERBOARD," Mattel logos, foot-pad and fuzzy pink foot-strap (which are frequently missing from Mattel board props), zig-zagging pink and green fastening strips, and a hole in the front from where Marty would have removed the handle. The bottom features plastic detailing including two silver-colour hover pads.

This hoverboard exhibits wear from use and age, including adhesive residue around the fastening strips, cracks in the foam, and paint chipping throughout with the most extensive paint chipping around the hover pads. Dimensions: 71.25 cm x 21.75 cm x 6.5 cm (28" x 8.5" x 2.5")

Estimate. £60,000 - 100,000

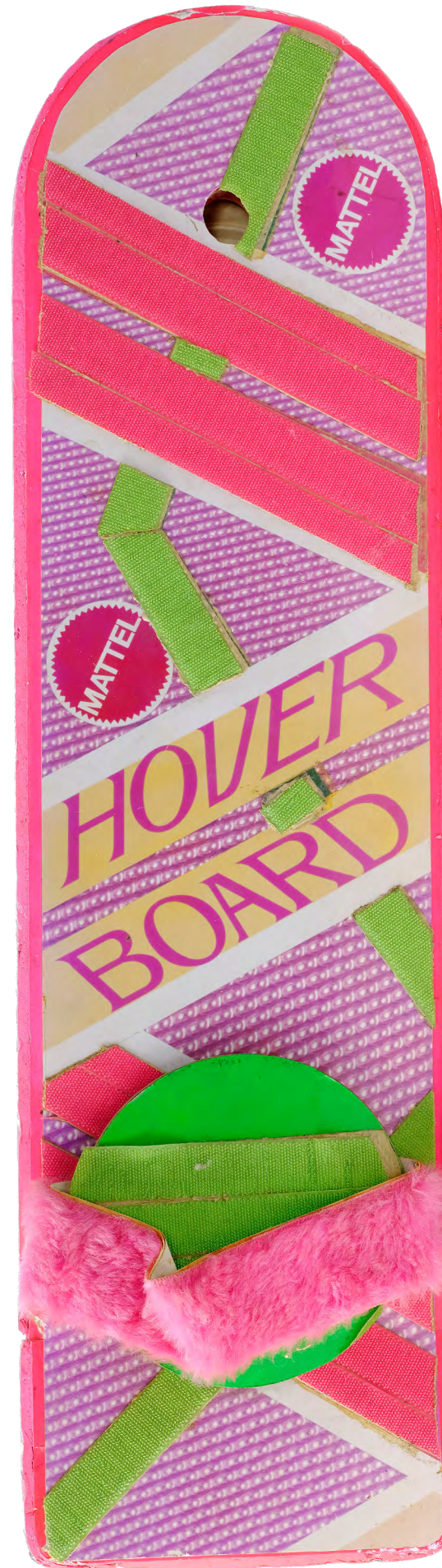

54
Spike's (Darlene Vogel)
Question Mark Hoverboard M
Back To The Future Part II (1989)

Spike's (Darlene Vogel) question mark hoverboard from Robert Zemeckis' sci-fi comedy sequel Back to the Future II. In the future of 2015, Spike was part of Griff Tannen's (Thomas F. Wilson) gang, who chased Marty McFly (Michael J. Fox) on hoverboards.

This hoverboard is made of lightweight rigid styrofoam painted black and gold throughout. It features neon-orange, brown and burgundy decals applied to the top, and neon-yellow, green and pink paint streaks on the bottom, including neon-pink question marks. Fixed to the bottom are two pieces of decorative black, grey and burgundy resin, painted to look like electromagnets. The hoverboard is missing its footpad and exhibits some paint chipping and small punctures to the foam from use. Dimensions: 75.5 cm x 24.5 cm x 5 cm (29 3/4" x 9 3/4" x 2")

Estimate. £20,000 - 30,000

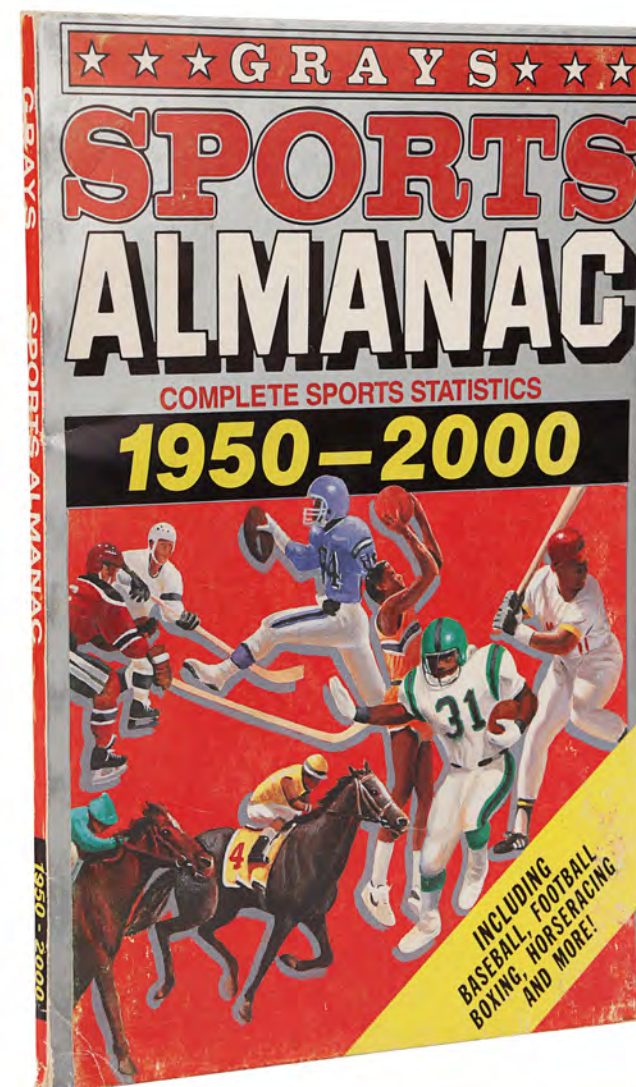

55
Sports Almanac M
Back To The Future Part II (1989)

A Sports Almanac from Robert Zemeckis' sci-fi sequel Back to the Future Part II. In the future of 2015, Marty McFly (Michael J. Fox) purchased a Sports Almanac from the Blast from the Past antique store. The book was then stolen by the elderly Biff (Thomas F. Wilson), who gave it to his younger self in 1955 to alter history in his favour. Marty and Doc Brown (Christopher Lloyd) then had to return to 1955 to prevent this from occurring.

This paperback book contains 288 pages detailing sports statistics from 1950 to 2000. It has a silver-and-red cover, which shows signs of age and production use, including discolouration and minor crease lines. Dimensions: 22.5 cm x 15 cm x 0.5 cm (8 3/4" x 6" x 1/4")

Estimate. £8,000 - 12,000

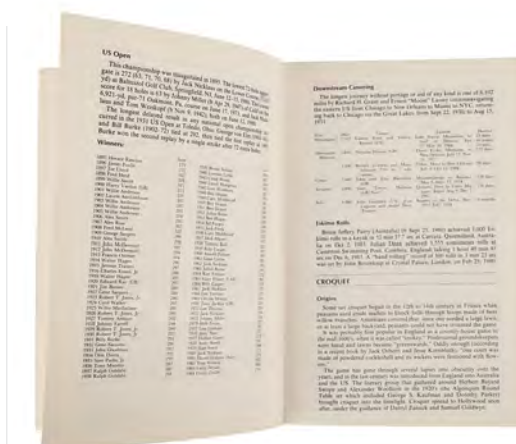

56
2015 Hill Valley Car Licence Plate Ω
Back To The Future Part II (1989)

A 2015 Hill Valley car licence plate from Robert Zemeckis' sci-fi adventure sequel Back to the Future Part II. Futuristic orange licence plates were affixed to vehicles travelling through 2015 Hill Valley.

This plastic licence plate features a barcode, number "911227173," registration state "California," and year "2015" applied to the front with foil. The reverse is hand-marked "Passenger (2) of 2 Jeep" and "Back to the Future" in marker with additional text faded from age. Each corner exhibits production-made holes for affixing the plate to a vehicle, and the foil exhibits warping from exposure. Dimensions: 30.5 cm x 15.25 cm x 0.75 cm (12" x 6" x 0.25")

Estimate. £3,000 - 5,000



57
Marty McFly's (Michael J. Fox)
Screen-Matched Poncho Ω
Back To The Future Part III (1990)

Marty McFly's (Michael J. Fox) screen-matched poncho from Robert Zemeckis' sci-fi adventure sequel Back to The Future Part III. McFly discarded his initial colourful cowboy outfit and swapped it for his poncho after Doc Brown (Christopher Lloyd) rescued him from Buford "Mad Dog" Tannen (Thomas F. Wilson) and his attempt to hang McFly.

Markings on this poncho and placement of certain threads screen-match it to one of several scenes where Marty wears this exact item. It can be viewed in the scenes where Doc and Marty attempt to power the DeLorean in 1885, and again as Marty attempts to rouse Doc from his binge. While the poncho was worn several different ways, the knotting of the wool filling yarn as it passed through the warp yarn created a one-of-a-kind and unique cluster of shapes and textures not found on any other poncho. A continuing play on Marty having identified himself to as "Clint Eastwood," this poncho is based on the real Clint Eastwood's poncho worn by his "Man with No Name" character in from "The Dollars Trilogy" of films.

This lot consists of a hand-woven rectangular wool poncho in earthen tones and pale red tassels. It features Native American-inspired key patterns as part of the design around the neck. The border of the poncho alternates between an "S" shape and the four-dot design found around the neck. This lot exhibits fraying threads, stiff fibres and loosened warp and filling yarn.

Estimate. £60,000 - 100,000



Photo 12 / Alamy Stock Photo





58
Marty McFly's (Michael J. Fox) Cowboy Boots Ω
Back To The Future Part III (1990)

Marty McFly's (Michael J. Fox) cowboy boots from Robert Zemeckis' sci-fi adventure sequel Back to The Future Part III. McFly wore his cowboy boots when he initially travelled back in time to 1885 to save his friend Doc Brown (Christopher Lloyd) from being murdered by Buford "Mad Dog" Tannen (Thomas F. Wilson).

This lot consists of a pair of leather cowboy boots (U.S. size 8). Designed by Tony Lama, these 1950's boots feature red and blue dye, faux snakeskin, and a wooden heel. They exhibit some scuffing on the outsole, fraying threads, faded blue colour, and a worn insole. Dimensions (each): 32.5 cm x 32.5 cm x 10.25 cm (12.75" x 12.75" x 4")

Estimate. £10,000 - 15,000

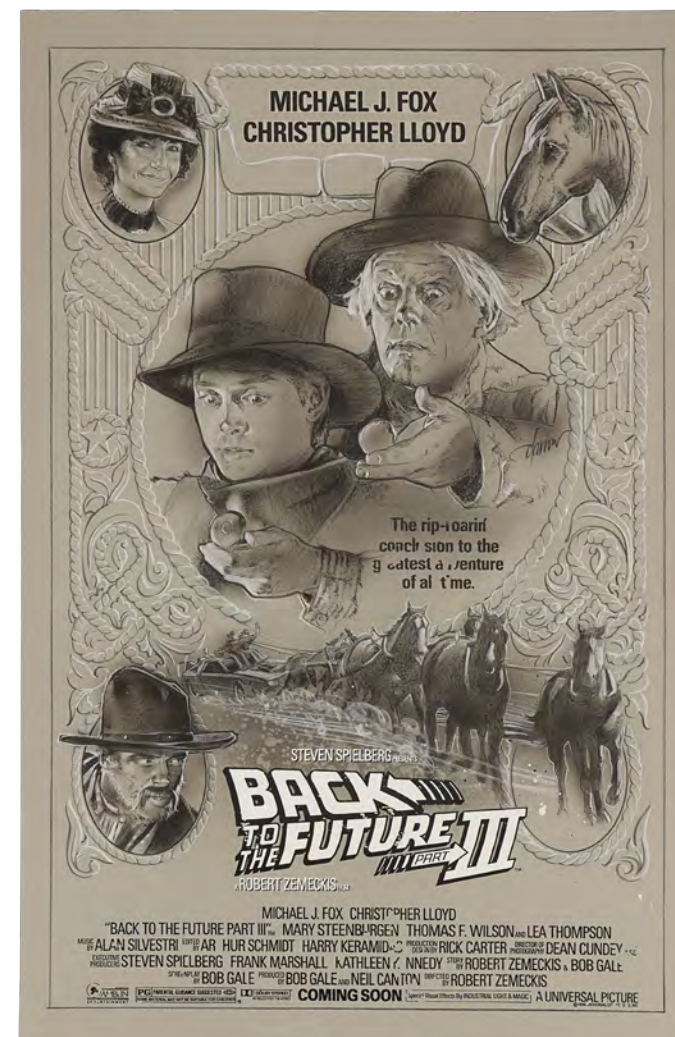

59
Hand-drawn Concept Poster Artwork
 by Dave Darrow M
Back To The Future Part III (1990)

A hand-drawn concept poster artwork by Dave Darrow from the promotion of Robert Zemeckis' sci-fi adventure sequel Back to the Future Part III.

This artwork is rendered in pencil on a grey A3 card glued to a foam board, and protected by a sheet of blue card taped along the top edge. It features portraits of the main characters Marty McFly (Michael J. Fox), Doc Brown (Christopher Lloyd), Clara Clayton (Mary Steenburgen) and Buford Tannen (Tom Wilson) framed by a braided Western-style motif. The piece also includes a dynamic illustration of Marty and Doc sitting atop a horse-drawn DeLorean and Darrow's signature in black pencil to the right of Doc's portrait.

This preliminary design displays chromatic rub-downs of the film's title, the billing credits and the tagline "The rip-roarin' conclusion to the greatest adventure of all time". The rub-downs have worn away in some areas. Dimensions: 60.5 cm x 39.5 cm x 0.5 cm (23 3/4" x 15 1/2" x 1/4")

Sold without copyright; see copyright notice in the Buyer's Guide.

Estimate. £4,000 - 6,000



63 cm (24.75")

60
Plaster Batman (Michael Keaton)
Prototype Cowl Bust M
Batman (1989)

A plaster Batman (Michael Keaton) prototype cowl bust from the production of Tim Burton's superhero film Batman. Batman's original suit was designed by costume designer Bob Ringwood and created by Vin Burnham and co-sculptor Alli Eynon. This bust is one of two waste mould plaster-cast sculptures created to give director Burton a visualisation of the Batsuit concept before approving the production of the full costume.

The heavy bust is painted mostly black, with the exception of detailed green-coloured eyes and a peachy skin tone applied to the lower face. It features the iconic sculpted brow, pointy ears and scalloped edge of the cowl, and has been fixed to an oval wooden base, also painted black. The bust exhibits extensive scuffing and abrasions to the paintwork, and the tip of the right ear has broken from production use. Dimensions: 33 cm x 63 cm x 65 cm (13" x 24 3/4" x 25 1/2")

Estimate. £6,000 - 8,000



61
Gotham City Matte Painting M
Batman (1989)

A Gotham City matte painting from Tim Burton's superhero film *Batman*. This painting was created for a composite shot of Gotham City seen just before the Joker (Jack Nicholson) interrupted the broadcast of the Mayor's (Lee Wallace) press conference for the 200th-anniversary gala. The lot was originally from the collection of credited optical cameraman Antony Hunt.

The matte painting is rendered in mixed media on a glass panel and features black sections in the lower half where live-action footage was superimposed onto the scene. The artwork has a black-painted wooden frame with string on the reverse for wall mounting. There is damage to the two lower corners where the glass has previously broken away. The lot is accompanied by a letter of authenticity. Dimensions: 55.5 cm x 93 cm x 3.5 cm (21 3/4" x 36 1/2" x 1 1/2")

Sold without copyright; see copyright notice in the Buyer's Guide.

Estimate. £4,000 - 6,000



62
Miniature Model Batman M
Batman (1989)

A miniature Batman from Tim Burton's superhero film *Batman*. This miniature was placed in a 24-inch model of the Batwing, used to film the sequence where the vehicle crashed into the steps of Gotham Cathedral, after the Joker (Jack Nicholson) downed it with a shot from his long-barrelled pistol. The 24-inch model was built by visual effects model maker Robbie Scott who only had time to make one version of the model as it was required at very late notice.

The resin model shows Batman in a seated position, finished in black. It features the cowl, a small chest emblem and a yellow-coloured utility belt. It is missing its cape, and the left hand has broken away. There are patches of paint wear, most notably on the back, and visible glue remnants. Dimensions: 10.5 cm x 5 cm x 11.5 cm (4 1/4" x 2" x 4 1/2")

Estimate. £3,000 - 5,000



63
Production-made Batman (Michael Keaton) Chest Emblem M
Batman (1989)

A production-made Batman (Michael Keaton) chest emblem from Tim Burton's superhero film *Batman*. Batman wore his iconic chest emblem on his batsuit while he fought crime in Gotham City.

This resin emblem was a test version made for the film but ultimately unworn. It features a raised bat logo painted black against a yellow backing, with a raised black edge. On the reverse is the number "010" repeated twice and the letters "AeD" handwritten in black ink. This item comes from the personal collection of Michael Keaton's movement double Carl Newman, who was gifted it on the production, and it is accompanied by a letter of authenticity from him. Dimensions: 15 cm x 11.5 cm x 0.5 cm (6" x 4 1/2" x 1/4")

Estimate. £5,000 - 7,000



64
Production-made Batman (Michael Keaton) Cowl M
Batman (1989)

A production-made prototype Batman (Michael Keaton) cowl from Tim Burton's superhero film *Batman*. Batman wore his cowl to disguise his identity and intimidate evildoers in Gotham City.

This black cowl, designed by Bob Ringwood and sculpted by Vin Burnham, is a prototype version with seams up the sides of the ears. This style can be seen in test fitting photos but ultimately wasn't used for filming.

It is made from foam latex and features the iconic pointy ears, sculpted brow and scalloped edges. To retain its shape, the cowl has been glued to a black fibreglass shell with metal rods supporting the nose and ears. This is mounted on a metal pole fixed to a circular black plastic base. The cowl exhibits wear from age and production use, including slight deterioration and creasing of the foam latex, and a hole on the front neck next to a previously repaired tear that runs up to the mouth. Dimensions: 25 cm x 46 cm x 56 cm (10" x 18" x 22")

Estimate. £3,000 - 5,000



65
Joker's (Jack Nicholson)
Silk Handkerchief †Δ
Batman (1989)

Joker's (Jack Nicholson) handkerchief from Tim Burton's superhero film Batman. The Joker wore a handkerchief tucked into the breast pocket of his jacket during a summit with Gotham City's crime lords, and when he approached Vicki Vale (Kim Basinger) at the Gotham Museum of Art. He notably used the handkerchief to wipe his brow after killing Antoine Rotelli (Edwin Craig), revealing his clown-white complexion underneath.

Created by Academy Award®-nominated costume designer Bob Ringwood, the Joker's costumes were designed in vibrant colours to express the character's mindset. The handkerchief is made from green-coloured silk and still features remnants of make-up from production. The lot displays patches of discolouration. Dimensions (unfolded): 42 cm x 40 cm (16 ½" x 15 ¾")

Estimate. £3,000 - 5,000



66
The Penguin's (Danny DeVito)
Make-up Test Casting M
Batman Returns (1992)

The Penguin's (Danny DeVito) make-up test casting from the production of Tim Burton's superhero sequel Batman Returns. This plaster head was made early during production to test ideas from The Penguin's final make-up.

The head is sculpted from plaster and moulded to a metal pole attached to a heavy, square wooden base. The face features a cross-hatched texture and is painted in a pink skin tone, with darker blues and purples around the eyes and lips. The cast exhibits some wear from production use, including a broken ear tip, abrasions which have caused paint wear, rust to the metal pole, and staining to the head and wooden base.

Dimensions: 45 cm x 44.5 cm x 47.5 cm (17 ¾" x 17 ½" x 18 ¾")

Estimate. £3,000 - 5,000

Propstore

Sell Your Music Memorabilia

Achieve world record prices for music memorabilia

Oasis Noel Gallagher's Custom Silver Sparkle Gibson Les Paul Florentine Guitar

est. £300,000- £500,0000



Reach out for a free appraisal and valuation with our specialists



Email: consign@propstore.com
Phone UK Office: +44 (0) 1494 766485
Phone US Office: +1 818 727 7829

Scan QR code to visit propstore.com/sell



Maximum Film / Alamy Stock Photo



67
Penguin's (Danny DeVito) Motorised Spinning and Pyro SFX Umbrella Ω
Batman Returns (1992)

Penguin's (Danny DeVito) motorised spinning and pyro SFX umbrella from Tim Burton's superhero sequel Batman Returns. Penguin (Danny DeVito) used one of his signature umbrellas to disarm Max Shreck (Christopher Walken), then fired blanks at Schreck to scare him.

Designed by production for the blank-firing scene, this umbrella features a metal shaft affixed with a battery pack-powered mechanical motor designed to twirl the nylon polyester canopy when connected to an AC power outlet. It also features a hollow metal end tip designed to resemble a gun barrel and previously equipped for pyrotechnic effects, as well as an extended resin handle painted brown to appear wooden, wrapped in black electric tape, and affixed with a small trigger which deploys the canopy.

The canopy itself is hand-painted black with a white latex spiral at centre. The umbrella exhibits flaking to the paint, rusting metal, loose rings, splintered resin, and exposed wiring from production and age. Its spinning functionality recently underwent sympathetic restoration. Dimensions: 104.25 cm x 10.25 cm x 10.25 cm (41" x 4" x 4")

Contains electrical components; see notice in the Buyer's Guide.

Estimate. £15,000 - 25,000



68
Fibreglass Batman (Michael Keaton)
Cowl Master Cast M
Batman Returns (1992)

A fibreglass Batman (Michael Keaton) cowl master cast from the production of Tim Burton's superhero sequel *Batman Returns*. Batman's original suit was designed by costume designer Bob Ringwood and created by Vin Burnham and co-sculptor Alli Eynon.

This black fibreglass master cast bust was made to visualise the look and fit of Batman's mask and was cast from the first production's plaster sculpt of Keaton's head by Jose Fernandez. The sculpture was commissioned because Keaton was unavailable at the time to be lifecast and was used to aid the visualisation of the cowl design for Burton's sequel. The texture on the cowl seen in the first film was removed in order to produce a sleeker and more streamlined appearance. The bust comprises Batman's head and shoulders, covered by the sculpted brow, pointy ears and scalloped edges of the mask. There are signs of restoration on the forehead and the tip of the right ear is damaged. Dimensions: 38 cm x 55 cm x 55.5 cm (15" x 21 3/4" x 22")

Estimate. £6,000 - 8,000



69
Catwoman (Michelle Pfeiffer)
Cowl Production Master M
Batman Returns (1992)

The Catwoman (Michelle Pfeiffer) cowl production master from the production of Tim Burton's superhero sequel *Batman Returns*. This master was used by the costume department and special effects team as a basis for constructing Catwoman's stapled-together latex cowl.

The hollow resin head was cast from Pfeiffer's own and features the exact placement for the staples and latex patches that make up the cowl. There is minor damage to the left ear point. Dimensions: 23 cm x 19 cm x 25.5 cm (9" x 7 1/2" x 10")

Estimate. £6,000 - 8,000



70
Robin's (Chris O'Donnell) Costume Display
Comprised of Original and Replica Components M
Batman Forever (1995)

Robin's (Chris O'Donnell) costume from Joel Schumacher's superhero sequel *Batman Forever*. After his family was murdered by Two-Face (Tommy Lee Jones), Dick Grayson joined Batman (Val Kilmer) as his sidekick Robin, with a mask and suit designed in the film by Alfred Pennyworth (Michael Gough). This outfit consists of a mixture of production-used and replica components.

The costume comprises an original black rubber eye mask; an original stunt cape; reproduction urethane-rubber-moulded armour adhered to a foam-latex suit; an original "R" chest emblem; a pair of replica leather gloves featuring their original fins; an original rubber utility belt; and a pair of replica leather boots complete with original decorative bird-style motifs.

The armour is an exact replica and was cast from an original screen-used suit, and the gloves and boots were constructed from original production-used patterns. The costume comes presented on a custom mannequin featuring O'Donnell's likeness, and the black finish on the cape exterior exhibits notable wear. Dimensions (display): 46 cm x 77 cm x 178 cm (18" x 30 1/4" x 70")

Special shipping required; see special shipping notice in the Buyer's Guide.

Estimate. £8,000 - 12,000

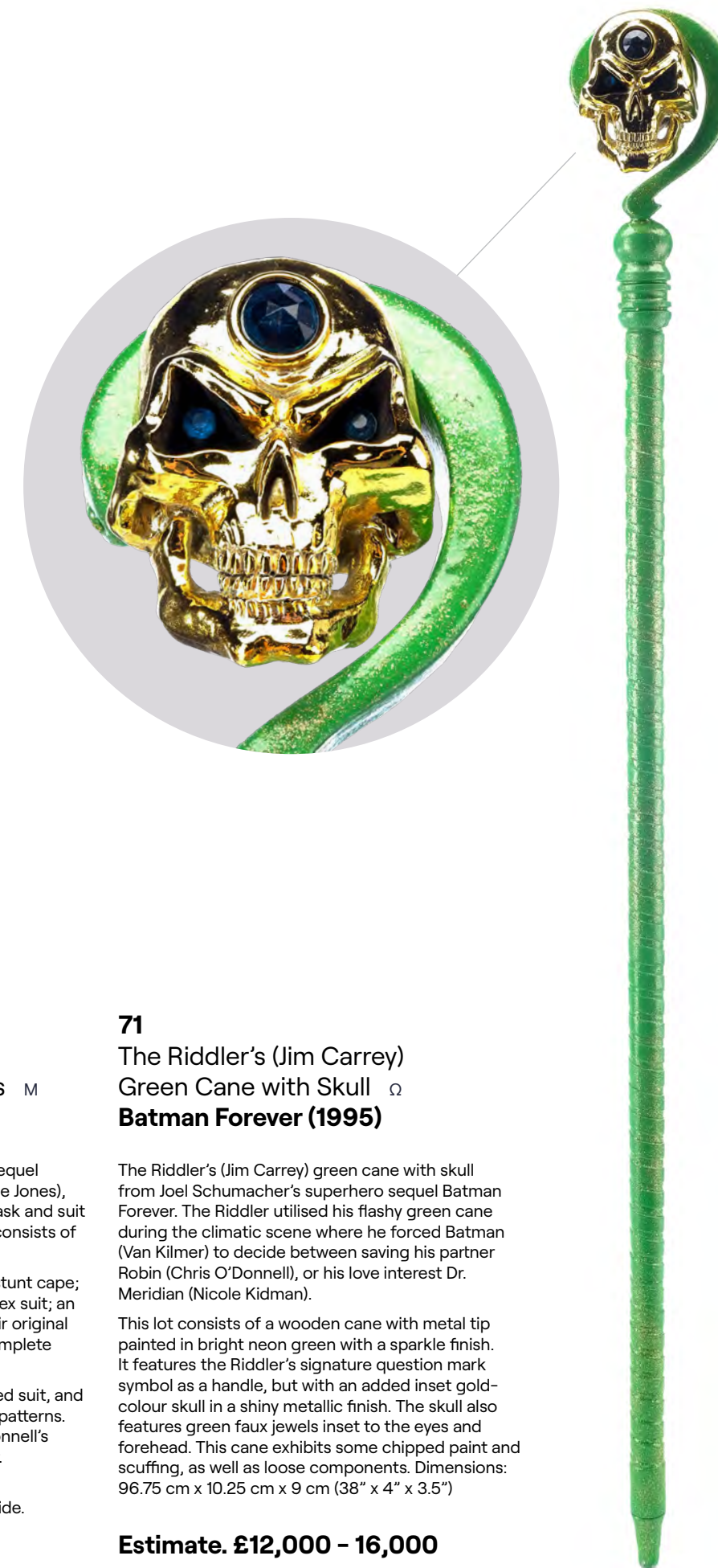

71
The Riddler's (Jim Carrey)
Green Cane with Skull Ω
Batman Forever (1995)

The Riddler's (Jim Carrey) green cane with skull from Joel Schumacher's superhero sequel *Batman Forever*. The Riddler utilised his flashy green cane during the climatic scene where he forced Batman (Val Kilmer) to decide between saving his partner Robin (Chris O'Donnell), or his love interest Dr. Meridian (Nicole Kidman).

This lot consists of a wooden cane with metal tip painted in bright neon green with a sparkle finish. It features the Riddler's signature question mark symbol as a handle, but with an added inset gold-colour skull in a shiny metallic finish. The skull also features green faux jewels inset to the eyes and forehead. This cane exhibits some chipped paint and scuffing, as well as loose components. Dimensions: 96.75 cm x 10.25 cm x 9 cm (38" x 4" x 3.5")

Estimate. £12,000 - 16,000



72
The Riddler's (Jim Carrey)
Light-up Brain-drain Machine ^M
Batman Forever (1995)

The Riddler's light-up brain-drain machine from Joel Schumacher's superhero sequel *Batman Forever*. The machine was invented by The Riddler (Jim Carrey) and then mass-produced by his company Nygmatech as television equipment for the residents of Gotham City. It enabled The Riddler and his partner in crime Two-Face (Tommy Lee Jones) to read the minds of its users.

The machine features a resin conical base that is painted silver and has a clear plastic bubble window, beneath which is the Nygmatech name and logo. It also features a spiral tube light around the base; a metallic midsection with a rotating centre, onto which are fixed two green triangular acrylic appendages; a clear conical acrylic container filled with broken pieces of white plastic tubing; and a resin lid painted silver, at the centre of which is another clear plastic bubble window. The machine has a power lead emerging from its base that is connected to a box switch and a three-pin plug. When switched on, the spiral tube light illuminates, the green plastic appendages rotate, and a flashing light emerges from the bubble window at the base. The machine comes in a black cardboard box featuring the Nygmatech name and logo in green lettering and a picture of an illuminated machine at the front and rear. Dimensions: 42 cm x 16.5 cm x 16.5 cm (16 1/2" x 6 1/2" x 6 1/2")

Contains electronics; see electronics notice in the Buyer's Guide.

Estimate. £4,000 - 6,000



73
The Riddler's (Jim Carrey)
Functioning Bat Bomb ^{†Δ}
Batman Forever (1995)

The Riddler's (Jim Carrey) functioning bat bomb from Joel Schumacher's superhero sequel *Batman Forever*. The Riddler destroyed the Bat Cave with bat bombs when he and Two-Face (Tommy Lee Jones) broke into Wayne Manor on Halloween night.

This green resin bomb consists of a small head, a larger body decorated with a black question mark emblem, and a pair of wings. An LR-1 battery-powered motor within the body makes the wings flap when the head is twisted into an upright position. The lot exhibits minor scuffing from production and comes with a custom-made display. Dimensions (bomb): 8.5 cm x 19 cm x 6.5 cm (3.25" x 7.5" x 2.5"); (display): 12 cm x 24.5 cm x 24.5 cm (4.75" x 9.5" x 9.5")

Contains electronics and mechanical components; see notice in the Buyer's Guide.

Estimate. £3,000 - 5,000



74
Production-made Two-Face
(Tommy Lee Jones) Suit ^M
Batman Forever (1995)

A production-made Two-Face (Tommy Lee Jones) suit from Joel Schumacher's superhero sequel *Batman Forever*. Two-Face wore a paint-splatter suit when he and Spice (Debi Mazar) entered the Nygmatech party to rob the guests and lure Batman (Val Kilmer) into a trap.

Custom-made for the production but ultimately unseen, the costume comprises a black double-breasted two-piece suit; a bow tie with one half featuring a pink-and-purple gradient finish; a white polycotton shirt (marked "XL5, 17-17 1/2"); and a pair of black leather shoes, one of which features metal studs and a skull-shaped toecap.

One half of the jacket and trousers are decorated with a pink-and-purple rubber paint-splatter pattern, a design feature intended to emphasise Two-Face's split personality. A tie-dye pattern adorns one half of the shirt front and collar. The costume is accompanied by a tag with the actor's name, listing the film as "Batman 3" and the character as "Harvey 2 Face".

Estimate. £1,000 - 1,500



75
The Joker's (Heath Ledger) Stunt Shotgun ^M
Dark Knight, The (2008)

The Joker's (Heath Ledger) stunt shotgun from Christopher Nolan's superhero sequel *The Dark Knight*. After taking the firearm from the Bank Manager (William Fichtner) during the opening heist sequence, the Joker used his shotgun repeatedly, most notably when crashing Bruce Wayne's (Christian Bale) fundraising party in the hopes of finding and killing Harvey Dent (Aaron Eckhart).

This foam-rubber weapon is based on a sawn-off Remington 870 shotgun, featuring the gun's serial numbers and manufacturer's details on its barrel and receiver's left side. It is painted black with a silver-toned barrel detail and a painted wood-effect handle and forearm grip. The shotgun exhibits scratches and paint wear from production use. Dimensions: 61 cm x 5 cm x 8.5 cm (24" x 2" x 3 1/4")

Restricted ownership; see replica firearm notice in the Buyer's Guide.

Estimate. £8,000 - 12,000



76
 James Gordon's (Gary Oldman) Hero Smith & Wesson 5904 and Police Badge M
Dark Knight, The (2008)

James Gordon's (Gary Oldman) hero Smith & Wesson 5904 and police badge from Christopher Nolan's superhero sequel *The Dark Knight*. Gordon used his sidearm throughout the film and wore his police badge clipped to his belt.

The gun is a real deactivated 9mm calibre Smith & Wesson 5904 featuring a textured grip, a movable trigger, slide and hammer, and an ejectable magazine clip. It is accompanied by a certificate of deactivation.

The badge is made of faux-silver cast resin, and features the Gotham City emblem at its centre, with "City of Gotham Police Department" etched around its curved edge. The badge fastened to an oval-shaped piece of black leather with a black metal clip on the back. The pistol's black paintwork displays scuffs, revealing patches of its aluminium alloy frame. Dimensions (pistol): 19 cm x 3.5 cm x 14.5 cm (7 1/2" x 1 1/2" x 5 3/4")

Firearm deactivated; see firearm deactivation notice in the Buyer's Guide.

Estimate. £5,000 - 7,000



LANDMARK MEDIA / Alamy Stock Photo

77
 Batman's (Robert Pattinson) Batarang +Δ
Batman, The (2022)

Batman's (Robert Pattinson) batarang from Matt Reeves' superhero film *The Batman*. Batman used his batarang to cut the electric cable which threatened the lives of Gotham citizens at the arena during the climax of the film. His batarang also doubled as his chest emblem when clipped into his suit.

The batarang is made of resin, hand-painted to resemble metal. It has been intentionally distressed to appear scratched and well-used. It comes with a custom-made, clear acrylic display stand and a Warner Bros. certificate of authenticity. Dimensions: 1.5 cm x 33.5 cm x 7.5 cm (1/2" x 13 1/4" x 3")

Estimate. £10,000 - 15,000



78
Blade's (Wesley Snipes)
Screen-matched Costume and
Hero Daywalker Sword Display M
Blade (1998)

Blade's (Wesley Snipes) screen-matched costume and hero Daywalker sword display from Stephen Norrington's action-horror film Blade. Blade wore his costume throughout the film as he hunted vampires. Through the tarnishing on its buckles, the padded vest screen-matches the one seen in the climactic moment where Blade cut Deacon Frost (Stephen Dorff) in half.

The costume consists of a long imitation leather jacket; a black T-shirt (size "M"); a black padded vest with small pouches and resin buckles painted to look like metal; and a pair of black trousers. The vest has an intentional slash across the left breast revealing silver foil, and the left trouser leg has a cut on it. The trousers also have a sticky sheen to them.

The sword's handle is made from cast resin painted silver and black with symbol detailing, and its blade is made of aluminium to give the weapon a lightweight feel. The sword handle is worn, revealing the black resin underneath.

The costume and sword come on a custom-made display and the lot is accompanied by a certificate of authenticity from New Line Cinema. Dimensions (display): 36 cm x 55 cm x 182 cm (14 1/4" x 21 3/4" x 71 3/4")

Special shipping required; see special shipping notice in the Buyer's Guide.

Estimate. £40,000 - 60,000





79
Blade's (Wesley Snipes) Costume Display 
Blade Trinity (2004)

Blade's (Wesley Snipes) costume display from David S. Goyer's superhero horror sequel Blade: Trinity. A vampire born with the ability to walk in the sunlight, Blade wore his costume as he teamed up with a group known as the Nightstalkers to battle a resurrected Dracula (Dominic Purcell) and his murderous army of the night.

This costume consists of a dark red, long-sleeve bodysuit; a black zippered leatherette and nylon vest with padded armour blocks and metal buckles; black suede and neoprene gloves; black trousers marked "WES" in the interior; and a black imitation leather duster lined with red satin. This costume comes dressed on a custom mannequin affixed with a Wesley Snipes mannequin head. Boots were included to complete the display. This display exhibits some discolouration and scratching on the leather jacket. Dimensions: 189.25 cm x 66.25 cm x 35.75 cm (74.5" x 26" x 14")

Special shipping required; see notice in the Buyer's Guide.

Estimate. £8,000 - 12,000



80
Jack Burton's (Kurt Russell) Stunt Knife 
Big Trouble In Little China (1986)

Jack Burton's (Kurt Russell) stunt knife from John Carpenter's action comedy Big Trouble in Little China. Jack used his knife as his primary weapon throughout the film, including his climactic battle with Lo Pan (James Hong).

This wooden stunt knife has a metallic-painted serrated blade with a black-painted handle. There is a small chip in the wood and some glue remnants on one side of the bolster and handle. Dimensions: 28.5 cm x 6 cm x 2 (11 1/4" x 2 1/2" x 1")

Estimate. £6,000 - 8,000



81
 Roy Batty's (Rutger Hauer)
 Screen-matched Leather Coat M
Blade Runner (1982)

Roy Batty's (Rutger Hauer) screen-matched leather coat from Ridley Scott's dystopian sci-fi thriller Blade Runner. Batty wore his coat for most of the film as he and the other fugitive replicants were hunted by Rick Deckard (Harrison Ford) and it screen-matches to several shots in the film through notable creases, most notably around the collar, as well as some promotional shots.

The coat is predominantly made of black leather, and features padded piping around the collar, cuffs, pockets, elbows and hem, with three metal buckles on its front.

After production, the coat was donated to a charity auction for the Verity Bargate Award at the Soho Theatre in London by Sandy Lieberman, who worked at film distribution company Goldcrest Films as Chief of Production at the time of the donation.

It is accompanied by a letter contemporaneous to the original auction and a handwritten note on Lieberman's headed paper. The coat has signs of wear from production use, most notably water damage from scenes set in the rain. The black has come off the padded piping in many places, revealing an orange layer beneath, and the coat has become discoloured.

Estimate. £30,000 - 50,000



United Archives GmbH / Alamy Stock Photo



PictureLux / The Hollywood Archive / Alamy Stock Photo





82
 Rachel Marron's (Whitney Houston) Screen-matched Complete Hero "Queen of the Night" Costume and Original Vac-Formed Lifecast M
Bodyguard, The (1992)

Rachel Marron's (Whitney Houston) screen-matched complete hero "Queen of the Night" costume and original vac-formed lifecast from Mick Jackson's romantic thriller *The Bodyguard*. Rachel wore her costume when she performed the song "Queen of the Night" in a nightclub. The performance was halted after fans stormed the stage, and Frank (Kevin Costner) carried Rachel to safety - the iconic image featured on the poster for the movie. *The Bodyguard* was Whitney Houston's acting debut.

This full and complete hero costume worn by Whitney Houston was originally obtained from a crew member. The positioning of the rips on the leotard screen-match the costume to a deleted scene, in which Frank undressed Rachel at home after the show.

The "Queen of the Night" costume was created by Global Effects Inc - known for their work in crafting suits of armour. The costume comprises a chrome fibreglass headdress; a beaded high-necked collar; a chrome-finished vacuum-formed plastic bodice piece; an embellished fabric bodice with cut-out sections on the front and decorative beads; a metallic under-leotard with studded suspenders that attach to the boots; a pair of thin metal-laced armbands; a pair of black full-length beaded gloves; a belt featuring several attached strands of beads; a pleated metallic lamé crepe partial skirt; a pair of black tights; and a pair of thigh-high heeled boots with diamond-shaped decoration down their outer sides. There are intentional rips and tears on the leotard, added by the production to purposely create a dishevelled look for the deleted scene after the concert.

Accompanying the costume is an original vacuum-formed plastic lifecast of Whitney Houston's face presented on a custom-made stand. This casting was used for costume fitting, and the headdress included in this lot fits the lifecast exactly. Completing the lot is a sealed vinyl edition of *The Bodyguard* soundtrack and two stills from the film. The headdress displays minor damage revealing the fibreglass underneath, and one corner of the bodice has broken off, as happened during the filming of the deleted scene. Several of the beads have come away on multiple components over time. Dimensions (face casting displayed): 20 cm x 20 cm x 38.5 cm (8" x 8" x 15 1/4")

A percentage of the hammer proceeds from this item are being donated to the National Autistic Society.

Estimate. £40,000 - 60,000



Maximum Film / Alamy Stock Photo



Maximum Film / Alamy Stock Photo



Ben Glass/Warner Bros./Regency/Canal +/Kobal/Shutterstock



83
 Frank Farmer's (Kevin Costner) Screen-matched
 Katana and Robin Miller-Signed Wakizashi Ω
Bodyguard, The (1992)

Frank Farmer's (Kevin Costner) screen-matched katana and Robin Miller-signed wakizashi from Mick Jackson's romantic thriller *The Bodyguard*. Rachel Marron (Whitney Houston) grabbed a katana displayed on the wall in Frank's basement. Frank threw Rachel's silk scarf in the air, which sliced in two when it hit the blade. Marks on the blade's base and patterning on the scabbard match it to close-up shots of the sword being drawn.

The katana comprises a curved steel blade with a bronze-colour metal strip at the base, a detailed floral-shaped guard, and a leather grip featuring woven cord. It comes with a black leather scabbard with an ornate metal tip and strands of metallic gold cord wrapped around one end. Also included is a matching wakizashi signed by prop master Robin Miller. Some of the cord on both weapons has begun to fray over time, the katana's scabbard exhibits minor marks, and the wakizashi's metal exhibits tarnishing. Dimensions (katana in scabbard): 99 cm x 9 cm x 9 cm (39" x 3 1/2" x 3 1/2"); (wakizashi in scabbard): 40.75 cm x 10.25 cm x 10.25 cm (16" x 4" x 4")

Estimate. £4,000 - 6,000



84
 Hand-painted Portrait
 of Dirk Diggler (Mark Wahlberg) M
Boogie Nights (1997)

A hand-painted portrait of Dirk Diggler (Mark Wahlberg) from Paul Thomas Anderson's comedy-drama *Boogie Nights*. While Diggler showed Amber Waves (Julianne Moore) around his new mansion, he paused in the living room to speak with Jessie St. Vincent (Melora Walters) as she applied finishing touches to the portrait. She informed him that she "used a little poetic licence to capture your essence".

Rendered in oil on canvas and depicting a shirtless Diggler against a sky blue background, the painting is one of two Diggler portraits by St. Vincent that adorned the actor's mansion.

Dimensions: 90 cm x 61 cm x 2.5 cm (36" x 12" x 1")

Estimate. £4,000 - 6,000



85
 Jason Bourne's (Matt Damon) Hero Glock M
The Bourne Ultimatum (2007)

Jason Bourne's (Matt Damon) hero Glock from Paul Greengrass' action sequel *The Bourne Ultimatum*. Bourne carried his Glock 17 9mm pistol during the climactic scenes in New York City. The pistol has been sympathetically deactivated, with a blocked barrel, and marked with the proof house stamp, but the trigger, slide and magazine all still move. The pistol comes in a padded metal carrying case along with copies of the production's gun rental agreements. It has some wear from production use, including some scratches. Dimensions: 19.5 cm x 3 cm x 13 cm (7 3/4" x 1 1/4" x 5")

Firearm deactivated; see firearm deactivation notice in the Buyer's Guide.

Estimate. £4,000 - 6,000

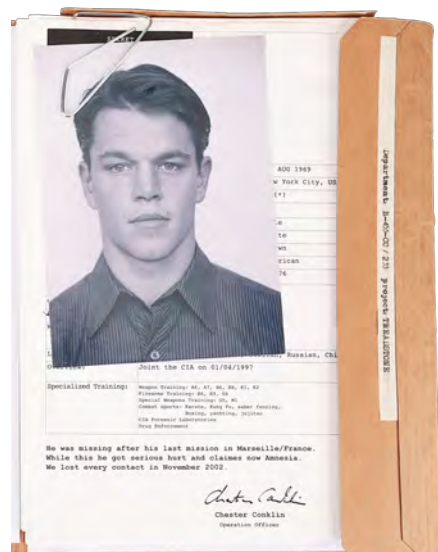
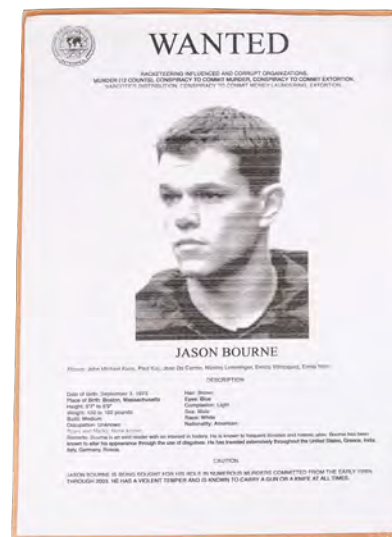

86
Jason Bourne's (Matt Damon)
Intelligence File ^M
Bourne Ultimatum, The (2007)

Jason Bourne's (Matt Damon) intelligence file from Paul Greengrass' action-thriller sequel The Bourne Ultimatum. Bourne's identity file is opened by Pamela Landy (Joan Allen) during a meeting, where she is instructed by CIA director Ezra Kramer (Scott Glenn) to continue pursuing Bourne.

The folder is made of brown card and features a label reading "Department: B-453-CC/233, Project: Treadstone". An assortment of paperwork relating to Bourne is contained within, including a black-and-white headshot; scanned images of various passports; two "Wanted"-poster-style sheets; medical examinations; and bank statements. Multiple pages display printed handwritten annotations, and the folder exhibits signs of creasing. Dimensions: 30 cm x 23.5 cm x 1.5 cm (11 3/4" x 9 1/4" x 1/2")

Estimate. £4,000 - 6,000



87
Walter White's (Bryan Cranston)
Hazmat Suit and Mask ^M
Breaking Bad (T.V. Series, 2008 - 2013)

Walter White's (Bryan Cranston) hazmat suit and mask from Vince Gilligan's crime-thriller series Breaking Bad. Walter and Jesse Pinkman (Aaron Paul) wore their iconic yellow hazmat suits and this style of gas mask while cooking crystal meth in various episodes throughout Seasons 3 and 4. In 2015 one of Walter's hazmat costumes was added to the Smithsonian Institute's permanent collection, cementing the series' place in pop-culture.

The costume comprises a yellow hooded hazmat suit made from rubber and synthetic fabric; a rubber and glass NIOSH-approved 3M respirator mask; and a pair of blue rubber gloves. "WW" is written in black ink on the inside of the suit's collar and on the mask's interior. There are signs of scratching to the glass, marks on the costume, and the lot is accompanied by a Sony Pictures certificate of authenticity.

Estimate. £4,000 - 6,000



88
Jesse Pinkman's (Aaron Paul)
Hazmat Suit and Mask ^M
Breaking Bad (T.V. Series, 2008 - 2013)

Jesse Pinkman's (Aaron Paul) hazmat suit and mask from Vince Gilligan's crime-thriller series Breaking Bad. Jesse and Walter White (Bryan Cranston) wore their iconic yellow hazmat suits and this style of gas mask while cooking crystal meth in various episodes throughout Seasons 3 and 4. In 2015, one of Jesse's hazmat costumes was added to the Smithsonian Institute's permanent collection, cementing the series' place in pop-culture.

The costume comprises a yellow hooded hazmat suit made from rubber and synthetic fabric; a rubber and glass NIOSH-approved 3M respirator mask; and a pair of blue rubber gloves. The inside of the suit's collar is labelled "Jesse" in black ink, and the initials "JP" are written on the mask's interior. There are signs of scratching to the glass and the zip is temperamental. The lot is accompanied by a Sony Pictures certificate of authenticity.

Estimate. £4,000 - 6,000



89
Production-used
Insert Clapperboard ^M
Breaking Bad (T.V. Series, 2008-2013)

A clapperboard from the production of Vince Gilligan's multi-award winning crime-thriller TV series Breaking Bad. The clapperboard was used by the "B" camera unit, most likely during filming of the third-season episode "Half Measures".

This is a small-sized clapperboard, used for insert shots. The clapperboard consists of an acrylic slate with a wooden clapper fixed to the top. It features the series logo, with fields situated above for the roll, scene and take number. The names of director Adam Bernstein and cameraman Michael Slovis are also included. Dimensions: 15 cm x 14 cm x 2 cm (6" x 5 1/2" x 3/4")

Estimate. £4,000 - 6,000



90
Jesse Pinkman's (Aaron Paul)
Mexican Superlab Gas Mask ^Ω
Breaking Bad (T.V. Series, 2011)

Jesse Pinkman's (Aaron Paul) Mexican superlab gas mask from Vince Gilligan's crime thriller series Breaking Bad. In Season 4, Pinkman wore a unique gas mask when he taught the Mexican cartel how to make his and Walter White's (Bryan Cranston) signature Blue Sky crystal meth in their superlab.

Unlike other commercially available gas masks seen in the series, this style of gas mask was custom-made for Paul by production. It consists of a black MSA 10025286 gas mask with a grey rubber strap for cinching to the head and a NIOSH-approved 3M organic vapour cartridge 6001 affixed on front. Also included is a Sony Certificate of Authenticity. The rubber and plastic exhibit scratching and scuffing from production wear.

Estimate. £5,000 - 7,000

punch much more effective than a jab and very instrumental in the success of your sparring and fighting. It will be your most usable and dependable weapon. Like the other punching techniques, from the paper target you can substitute more solid targets to develop your power.

Lee used to concentrate heavily on the straight lead punch in his daily training schedule, using different apparatus. In photos 1 and 2, he uses a punching pad. Sometimes he drew his right hand back to throw a much heavier blow, as in photos A and B, to simulate close fighting.

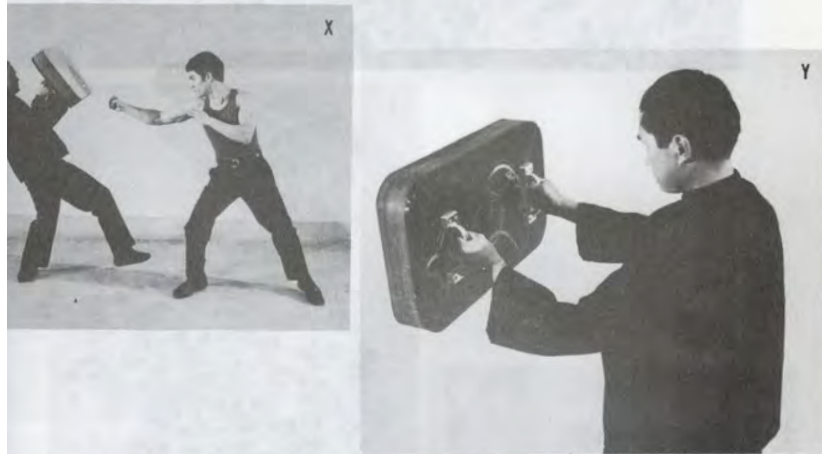

Another apparatus used in his training was the light shield, as in photos X and Y, Lee liked to use various hitting equipment because he used to say, "I don't know the true feeling of hitting a person. First of all, each part of the human body has a different composition. You may hit a hard, bony substance or a soft, fatty area. And second, hitting with gloves on is different from bare knuckles. Unfortunately, using bare knuckles on your partner is not too practical."

The shield presents a different feeling when there is a contact. The shield is more solid than the pad and since the holder stands more firmly with both hands on the equipment, it will not give in, as the pad will. For a more punishing punch, Lee selects the canvas

73



91
Bruce Lee Photo-matched Striking Shield M
Bruce Lee

Bruce Lee's personal striking shield, owned and used by the martial arts pioneer during the mid-1960s. The shield is pictured being hit by Lee in his book *Bruce Lee's Fighting Method: Basic Training* (written 1966, published 1977), a copy of which is included in this lot.

Created by his friend and equipment maker George Lee, this is one of Lee's most historically significant shields. It is made of hard, black-lacquered plywood, with swirling patterns decorating its rear side. Lee was known to have painted such patterns on the back of his hand-held shields himself. These swirling patterns picture-match it to the one held by Lee's student Ted Wong in *Fighting Method*. A picture of Lee hitting this shield is also shown in the 2012 documentary *I am Bruce Lee*. Lee constantly adapted his training aids, and after using this shield for the book he reduced its width, as evidenced by the cut along one edge. The shield's handles were replaced with two unmatched round corner grips, and one of the original handle's fixing marks are still visible. There is some wear, cracks and chips from age and use on the shield's rear side, while its front face shows glue remnants, where the pad, now missing, was previously affixed.

This item was displayed at the martial arts SENI show at the London Soccerdome in 2014, alongside many other original pieces of Bruce Lee memorabilia. Lee originally gifted this shield to his friend and student Herb Jackson, and it comes with a letter of authenticity from Jackson's son. Dimensions: 47 cm x 37 cm x 11.5 cm (18 1/2" x 14 1/2" x 4 1/2").

Estimate. £20,000 - 30,000

**92**

Tang Lung's (Bruce Lee) Double Nunchaku † Way Of The Dragon, The (1972)

Tang Lung's (Bruce Lee) double nunchaku from Lee's martial arts movie *The Way of the Dragon*. Tang Lung used his nunchaku to defeat Ho's (Wei Ping-Ou) thugs in the alley behind the restaurant.

The Way of the Dragon is the most personal of all Bruce Lee's films, as it is the only complete movie to showcase Lee as the star, director, producer and writer. It is also notable for being the only film to feature "The Little Dragon's" breathtaking skill with the deadly double nunchaku – a discipline that requires remarkable timing, reflexes and impeccable spatial awareness.

Handmade to Lee's exact specifications, each pair of nunchaku from this unique double set is crafted from durable lightweight wood, wrapped in mesh strips, and then covered in a protective rubberised coating, with a metal chain and eye-hooks linking the two batons. Each pair was the perfect length and weight for Lee, and the bespoke covering delivered enhanced grip – a feature that was invaluable when filming in the exceptionally hot and humid climate of Hong Kong.

Lee typically used two types of nunchaku in his films: one with a strong but lightweight construction, and another even lighter design with exterior padding to protect actors from impact injuries. This set of nunchaku (one of only two) comes from the former category, and Lee used them to execute sections of the mesmerising double-nunchaku battle filmed at Golden Harvest Studios. Unlike its sister set, which has two parallel indentations running around the entire circumference of one of the four batons, this double set is entirely uniform in its design.

Time has oxidised the outer rubber coating, which now presents a lighter shade compared with its original appearance in 1972. However, the original colour is still apparent on the tips. Oxidation of the internal adhesive has also pulled the exterior rubber closer to the mesh strips wrapped around the wood, giving the nunchaku a more ribbed appearance. The lot is accompanied by a letter of authenticity from the family of Lee's close friend and training partner George Lee, which expands upon its history. Dimensions (each): 95 cm x 3.5 cm x 3.5 cm (37 1/2" x 1 1/2" x 1 1/2")

Ownership of this weapon may be restricted. Please enquire for further details. It is solely the buyer's responsibility to check, prior to ordering, the legal status of this prop within their own country and its importation therein.

Estimate. £30,000 - 50,000



PictureLux / The Hollywood Archive / Alamy Stock Photo

93
Tang Lung's (Bruce Lee)
Yellow Striking Pad M
Way Of The Dragon, The (1972)

Tang Lung's (Bruce Lee) striking pad from Lee's martial arts movie Way of the Dragon. Tang used various pads during the scenes set behind the restaurant when he practised martial arts with the waiters, including a yellow pad held up by Tony (Tony Liu). A lobby card featuring Tang and the pad accompanies this item.

Lee also used this pad on set to practice with. Lee was photographed kicking it on the Colosseum car-park fight set, with the pad held by Whang In Sik (Japanese Fighter). Lee also used the pad during test footage for his film Game of Death, which was ultimately unfinished due to Lee's untimely passing. This item was displayed at the martial arts show SENI, held at the London Soccerdome in 2014, with many other original pieces of Bruce Lee memorabilia and props.

The pad is covered with strong yellow material and has a dark-stitched handle. It displays dirt staining and wear from repeated use and age. Inherited by Lee's friend and student Herb Jackson, this historic, personal prop and training aide is accompanied by a letter of authenticity from the son of Jackson and Lee's close friend and student Taky Kimura. Dimensions 30.5 cm x 30.5 cm x 2.5 cm (12" x 12" x 1").

Estimate. £20,000 - 30,000



A lobby card featuring Tang (Bruce Lee) and the yellow pad held up by Tony (Tony Liu)



94
Bruce Lee's Persol Ratti Sunglasses Gifted by Steve McQueen †
Bruce Lee

Bruce Lee's Persol Ratti sunglasses. A pair of vintage Italian designer sunglasses with a patented folding frame design. They were originally owned by Hollywood superstar Steve McQueen, who gave them to Lee, his close friend and martial arts instructor.

Refined and timeless, these low-profile sunglasses were handcrafted by Persol in Lauriano, Italy. The brand formed a signature part of McQueen's style during the 1960s, and became part of Lee's iconic look in the '70s. Lee had admired the glasses during one of his many training sessions with McQueen. Lee didn't have a great deal of money at the time, so McQueen kindly gave them to his friend as a present at the end of the session.

The sunglasses are accompanied by a letter of authenticity from Lee's brother Robert. They also come with a magazine featuring a colour photograph of Lee wearing the glasses. Dimensions: 13 cm x 14.5 cm x 4.5 cm (5" x 5 3/4" x 1 3/4")

Estimate. £8,000 - 12,000



Photo excerpt from Bruce Lee: The Life, The Legacy, The Legend Poster Magazine ISSUE 6 - 50th Anniversary Edition

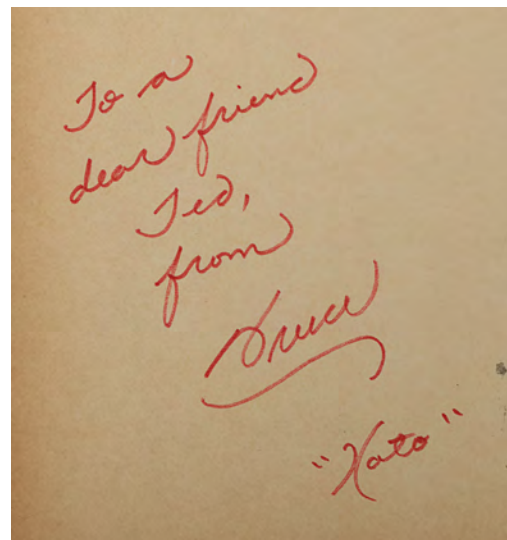

95
 "Kato's Revenge" Colouring Book
 Autographed by Bruce Lee †
Green Hornet, The (T.V. Series, 1966-1967)

An extremely rare and collectable edition of the vintage "Kato's Revenge" colouring book, published by the Watkins-Strathmore Company of Racine, Wisconsin in 1966. This 48-page book was marketed to fans of the Green Hornet TV series, which ran for 26 episodes between 1966 and 1967.

Martial arts legend Bruce Lee stole the show as Kato, the crimefighter who fought alongside the Green Hornet (Van Williams). When Lee began his film career Hong Kong in the early 1970s, he discovered that series was called The Kato Show, and that he was billed as the star.

This book is unique, as Lee dedicated it to his friend and student Ted Wong, as follows: "To a dear friend Ted, from Bruce 'Kato'". The juxtaposition of Lee's personal short-form signature with the Kato signature is exceptionally rare.

The pages intended for colouring are all unused. The book exhibits some mild surface abrasion on the front cover, as well as minor soiling from age on some of the pages. The lot is accompanied by a letter of authenticity from Lee's friend Taky Kimura. Dimensions: 27 cm x 20 cm (10 1/2" x 8")

Estimate. £4,000 - 6,000

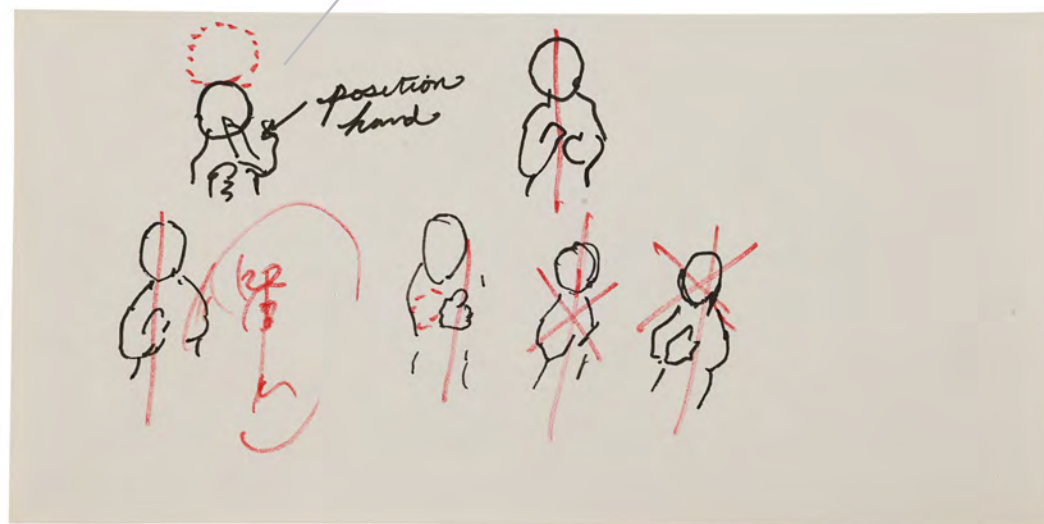

96
 Bruce Lee's Jeet Kune Do
 Centre-line Theory Drawing †
Bruce Lee

A centre-line theory drawing by martial arts legend Bruce Lee, created during the development of his revolutionary martial arts philosophy, Jeet Kune Do, or "The Way of the Intercepting Fist".

This rare hand-drawn illustration, rendered in black-and-red ink and annotated for additional clarity, delineates Lee's explanation of the centre-line theory - a key concept in Wing Chun. The drawing illustrates the correct hand positions and the functional goals to correctly exploit the theory in combat. It also highlights the incorrect or off-line positions.

In martial arts, a centre line refers to an imaginary line running through the centre of an opponent's body. A fighter will have a tactical advantage if they can exploit and control an opponent's centre line through accurate and strategic striking. This concept originates from classical Wing Chun, an art Lee studied under legendary Grandmaster Ip Man. However, Lee went on to evolve and modernise Wing Chun fighting techniques for more effective use in contemporary combat.

This drawing is accompanied by a letter of authenticity detailing its history and further expanding on centre-line theory. Dimensions: 7.5 cm x 15 cm (3" x 6")

Sold without copyright; see copyright notice in the Buyer's Guide.

Estimate. £4,000 - 6,000

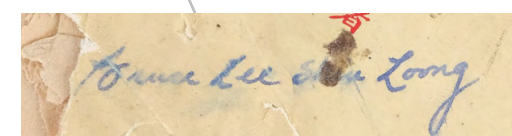
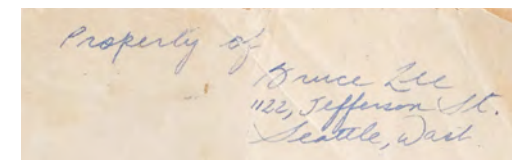

97
 Bruce Lee-Owned and Signed
 Martial Arts Booklet Ω
Bruce Lee

A martial arts booklet from the personal collection of legendary martial artist and media personality Bruce Lee. An avid reader and student throughout his life, Lee curated a personal library containing hundreds of books covering a rich and diverse educational spectrum, including volumes on the martial arts, western boxing, fencing, exercise, filmmaking, and philosophy.

Published by the Vih Mei Book Company of Hong Kong, this Chinese-language martial arts instructional booklet features 59 black-and-white pages containing a series of poses and diagrams with text. The cover is signed "Bruce Lee Shiu Long" in Lee's distinctive handwriting along with the notation "The Chinese twenty-four foot fighting technique." The back cover is signed "Property of Bruce Lee, 1122 Jefferson St, Seattle, Wash." in the same script.

Several pages have also been highlighted by Lee with numbers and outlines in ink, and a blank page in the booklet features a line of Chinese text also believed to have been handwritten in pencil by Lee. The booklet exhibits significant wear from age and use, including staining, creasing, tears on the cover, and missing edges on some of the interior pages, but still retains its vintage colouration and imagery. Dimensions: 20.5 cm x 15.5 cm (8" x 6")

Estimate. £4,000 - 6,000



98
 Prototype Captain America
 (Chris Evans) Helmet on a Bust M
Captain America: The First Avenger (2011)

A prototype Captain America (Chris Evans) helmet from the production of Joe Johnston's superhero film Captain America: The First Avenger. Captain America wore his helmet while fighting against the Red Skull (Hugo Weaving) and Hydra.

The helmet is made of rubber and leather, with a metal buckle on the chinstrap, and is intentionally distressed with scratches and dents. It sits upon a production-made bust modelled on Evans' face. This resin-and-biscuit foam bust was specially made to display the helmet through pre-production and during filming. Dimensions (bust): 21 cm x 33.5 cm x 39 cm (8 1/4" x 13 1/4" x 15 1/4")

Estimate. £6,000 - 8,000



99
 David Kleinfeld's (Sean Penn)
 Autographed Adidas Tracksuit M
Carlito's Way (1993)

David Kleinfeld's (Sean Penn) autographed Adidas tracksuit from Brian De Palma's crime drama Carlito's Way. Kleinfeld wore his tracksuit when he killed the Mob boss Tony Tagliabucchi (Frank Minucci) and his son Frankie (Adrian Pasdar) after being coerced into providing his yacht to assist in Tony's prison escape.

This green Adidas® tracksuit comprises a zip-up track jacket (size M), a pair of tracksuit bottoms (size M), and a pair of unsized white-and-green Adidas® Country OG trainers. The front of the track jacket and right trainer feature Sean Penn's autograph in blue pen. The trainers display scuffing from production use.

Estimate. £4,000 - 6,000



100
 Chuck Noland's (Tom Hanks) Screen-matched Hero Wilson Ω
Cast Away (2000)

Chuck Noland's (Tom Hanks) screen-matched hero Wilson from Robert Zemeckis' drama *Cast Away*. During his four years stranded alone on a desert island, plane-crash survivor Chuck created Wilson, his only companion, out of a volleyball he found in one of several FedEx packages that washed ashore. Both Chuck and Wilson's appearance became more dishevelled throughout the film as they spent more time on the island. Markings on the volleyball's 'face' screen match it to the scene in the cave after Chuck has created fire.

The off-white leather volleyball is intentionally distressed with a dark brown-and-red 'face', created in the film by Chuck's bloody handprint. It features a faded pair of eyes, nose, and mouth. The other side of the ball bears the Wilson® and Association of Volleyball Professionals logos. All minor signs of wear present on the lot are from use on production. Dimensions: 19 cm x 19 cm x 19 cm (7 1/2" x 7 1/2" x 7 1/2")

Estimate. £60,000 - 100,000



101
 Chuck Noland's (Tom Hanks)
 Screen-matched Ice Skate Axe Ω
Cast Away (2000)

Chuck Noland's (Tom Hanks) screen-matched ice-skate axe from Robert Zemeckis' drama Cast Away. While stranded on a desert island, Noland fashioned an axe out of an ice skate and a piece of wood, and used it to build the raft upon which he escaped the island. It matches the one seen on-screen through wear and markings on the boot, blade and handle.

The axe is made with an intentionally distressed ice skate lashed with a natural fibre rope around a wooden stick. The blade is made of metal. Dimensions: 61 cm x 9 cm x 16 cm (24" x 3 1/2" x 6 1/4")

Estimate. £3,000 - 5,000



102
 Chuck Noland's (Tom Hanks)
 Pocket-watch Necklace Ω
Cast Away (2000)

Chuck Noland's (Tom Hanks) pocket-watch necklace from Robert Zemeckis' drama Cast Away. Stranded plane-crash survivor Chuck was given a pocket watch by his girlfriend Kelly (Helen Hunt) before he set off on his doomed journey. He later wore it as a necklace while leaving his desert island on a raft.

The pocket watch is made of metal and attached to a length of brown string. The necklace also features a faux tooth, which Chuck removed using an ice skate. The watch and necklace have been intentionally distressed, and the watch itself does not open. Dimensions (watch): 7 cm x 5.5 cm x 1.5 cm (2 3/4" x 2 1/4" x 1/2")

Estimate. £3,000 - 5,000



103
 Good Guy Factory Doll Ω
Child's Play 2 (1990)

A Good Guy factory doll from John Lafia's horror sequel Child's Play 2. Multiple Good Guy dolls were seen at various stages of their production throughout the Play Pals Inc. factory sequence during the film's finale.

This doll is made of plastic, with resin eyes and a removable synthetic ginger wig. The doll's head and limbs are secured to the body by ball joints which allow them to be moved and rotated. The doll is dressed in custom-made clothing, comprising a striped long-sleeved knit top; a pair of dungarees featuring a toy print pattern; a pair of red socks; and a pair of red canvas shoes. Both the front pocket on the dungarees and the shoelaces display the doll's brand name, "Good Guys". This lot exhibits wear from production use, including yellow stains, plastic label tags in the dungarees, and a hinged cut-out panel at the top of the head which has since been glued shut. Dimensions: 77 cm x 64 cm x 18 cm (30 1/4" x 25 1/4" x 7")

Estimate. £8,000 - 12,000



104
 Screen-matched Melted Chucky Ω
Child's Play 2 (1990)

A screen-matched melted Chucky from John Lafia's horror sequel Child's Play 2. Andy (Alex Vincent) and Kyle (Christine Elise) trapped Chucky (voiced by Brad Dourif) in one of the machines at the Play Pals Inc. factory. After emerging from the machine, Chucky's body had been melted down, malformed and fused with extra doll limbs. The specific angles and shapes of the melted-down plastic, and the intentional distressing and fake blood placement, match this Chucky to the one seen on screen during this sequence.

The melted Chucky comprises multiple doll limbs melted together in a fused mass. It features foam-latex shoes and sections of distressed fabric taken from Chucky's clothing. Wiring runs inside to some electrical components, which would have created the smoke we see rising from the pile as it moves down the conveyor belt. The item has been secured to a green wooden base with metal screws and glue. It displays intentional scorch marks, stains, scratches, burnt plastic hair and dried fake blood. Dimensions: 48 cm x 55 cm x 36 cm (19" x 21 3/4" x 14 1/4")

Contains electronics; see electronics notice in the Buyer's Guide.

Estimate. £4,000 - 6,000



105
Peter Nelson Collection: Chitty Chitty Bang Bang Car Horn M
Chitty Chitty Bang Bang (1968)

A Chitty Chitty Bang Bang car horn from Ken Hughes' musical fantasy film Chitty Chitty Bang Bang. Inventor Caractacus Potts (Dick Van Dyke) built the titular flying car and took his children (Adrian Hall and Heather Ripley) and Truly Scrumptious (Sally Ann Howes) on a magical adventure to the land of Vulgaria.

Legendary production designer Ken Adam designed the car, and a total of six were built for the film, although only one was fully functional and road-worthy. Each car had a long serpentine hand-made horn that ran down the right-hand side of the vehicle.

This horn is made of brass and features a snake-head at one end, with a forked tongue and faux rubies for eyes. It has been mounted on a long clear piece of acrylic for display purposes and has some minor tarnishing. Dimensions (display): 180.5 cm x 15 cm x 20 cm (71" x 6" x 8")

From the personal collection of Peter Nelson, previously displayed at his two museums, "The Cars of the Stars" and "The Bond Museum" in Keswick, Cumbria, until they closed in 2011.

Special shipping required; see special shipping notice in the Buyer's Guide.

Estimate. £10,000 - 15,000



Atlaspix / Alamy Stock Photo



106
Satyr Full Creature Costume and Mask Display †Δ
Chronicles Of Narnia, The: Prince Caspian (2008)

A satyr full creature costume and mask from Andrew Adamson's fantasy sequel The Chronicles of Narnia: Prince Caspian. The satyr, a goat-like creature from Greek mythology, was one of numerous fantastical creatures which inhabited the otherworldly land of Narnia.

The satyr's head comprises foam-latex skin covered in grey hand-punched hair, curled resin horns, glass eyes, and a set of teeth. Intentional holes are situated on the satyr's neck to enable visibility for the actor wearing the piece.

The costume consists of a faux-fur bodysuit fitted over a shaped foam muscle suit that encompasses the character's chest, back and arms. A brown leather bandolier is situated on the satyr's right side and is labelled "#46". No legs were made for this particular costume as they were applied digitally during post-production. The tip of the right horn is slightly damaged and minor patches of fur have fallen away over time. The lot is presented on a custom-made stand, preserving the creature's original height, with a light-up base featuring the title artwork. Dimensions: 53 cm x 61 cm x 205 cm (21" x 24" x 80 3/4")

Special shipping required; see special shipping notice in the Buyer's Guide.

Contains electronics; see electronics notice in the Buyer's Guide.

Estimate. £4,000 - 6,000

107
Hand-Painted Mothership Lighting Concept Illustration Ω
Close Encounters Of The Third Kind (1977)

A hand-painted mothership lighting concept illustration from the production of Steven Spielberg's sci-fi film Close Encounters of the Third Kind. The dazzling, massive extraterrestrial mothership crash landed at Devils Tower, where its passengers formally encountered Roy Neary (Richard Dreyfuss) and the humans in the iconic finale.

This illustration was created to plan a composite shot of the ship's arrival. It consists of a printed photograph of the live-action scene adhered to black illustration board and taped over with a clear plastic cel hand-painted with the mothership's elaborate lighting scheme. The illustration is labelled "M76A-Z" in two places and believed to be rendered by production illustrator George Jenson. The board exhibits pinholes, worn borders, and some grime from production and age. Dimensions: 15.25 cm x 28 cm (6" x 11")

Sold without copyright; see notice in Buyer's Guide.

Estimate. £3,000 - 5,000

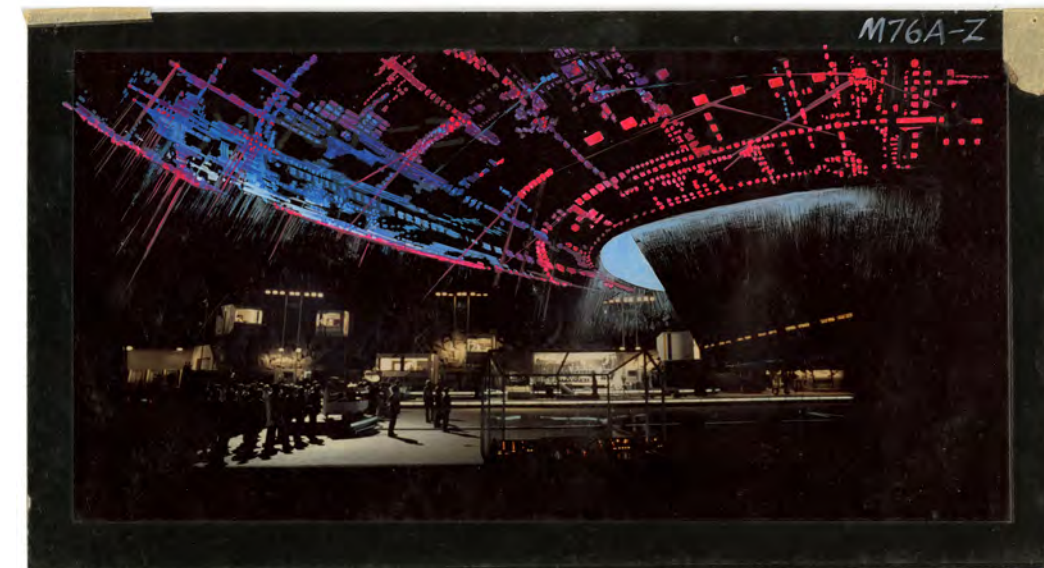

108

Alien Costume Display M

Close Encounters Of The Third Kind (1977)

An alien creature costume from Steven Spielberg's sci-fi drama Close Encounters of the Third Kind. Small alien creatures revealed themselves to humanity during the film's climax at Devils Tower.

The creature's head is made of durable slip latex and painted a grey-green colour. It has painted blue eyes and holes in the pupils to allow the child performer wearing the costume to see. The remainder of the costume comprises a spandex unitard. The costume is presented on a custom-made display stand. Dimensions (display): 30.5 cm x 40 cm x 100 cm (12" x 15 3/4" x 43 1/4")

Special shipping required; see special shipping notice in the Buyer's Guide.

Estimate. £20,000 - 30,000



109
Full-size Santi (Junio Valverde) Display Figure Ω
Devil's Backbone, The (2001)

A full-size display figure of Santi (Junio Valverde) from Guillermo del Toro's gothic horror *The Devil's Backbone*. Carlos (Fernando Tielve) encountered the ghostly apparition of Santi several times at the orphanage and discovered the tragic events that led to Santi's mysterious disappearance.

This figure was created by DDT, the Spanish studio behind the make-up and special effects for the film, founded by Academy Award®-winners David Martí and Montse Ribe. This model is a reproduction of the one created at the behest of del Toro for the 2016 exhibition "Guillermo del Toro: At Home with Monsters" and displayed at the Los Angeles County Museum of Art. Del Toro owns the original model from the exhibition.

The figure is constructed from polyester and polyurethane resins around a metal skeleton, with clay pressed pieces from the original production moulds attached. It is finished in sculpting clay and painted with enamels and acrylics.

Santi's pale skin is decorated with detailed cracking, notably on the head. Red-coloured cotton wool-like material - representing the blood always seen floating upwards from his head wound - is inserted into a slot on the head's temple. The figure is dressed in a brown natural hair wig; a diamond-patterned knitted vest; a heavily stained shirt; and a pair of brown textured shorts. The clothing is intentionally distressed, adding to the figure's creepy aesthetic, and the statue exhibits minimal signs of wear. Dimensions: 40 cm x 30 cm x 140 cm (15 3/4" x 11 3/4" x 55 1/4")

Special shipping required; see special shipping notice in the Buyer's Guide.

Estimate. £15,000 - 25,000



110
Dexter Morgan's (Michael C. Hall)
ID Card Ω
Dexter (T.V. Series, 2006 - 2013)

Dexter Morgan's (Michael C. Hall) ID card from James Manos, Jr.'s crime television series *Dexter*. Morgan, a vigilante serial killer who targeted other killers, wore and carried his ID as a bloodstain pattern analyst for the Miami-Metro Police Department throughout the series.

This plastic Miami-Metro Police Department employee identification card with a picture of Morgan is labelled for "Morgan, Dexter Forensic Technician." It comes in a black leatherette sleeve with a metal chain necklace. The ID exhibits some wear to the sleeve and indents on the back from production. Dimensions: 12.75 cm x 9 cm x 1.5 cm (5" x 3.5" x 0.5")

Estimate. £7,000 - 10,000

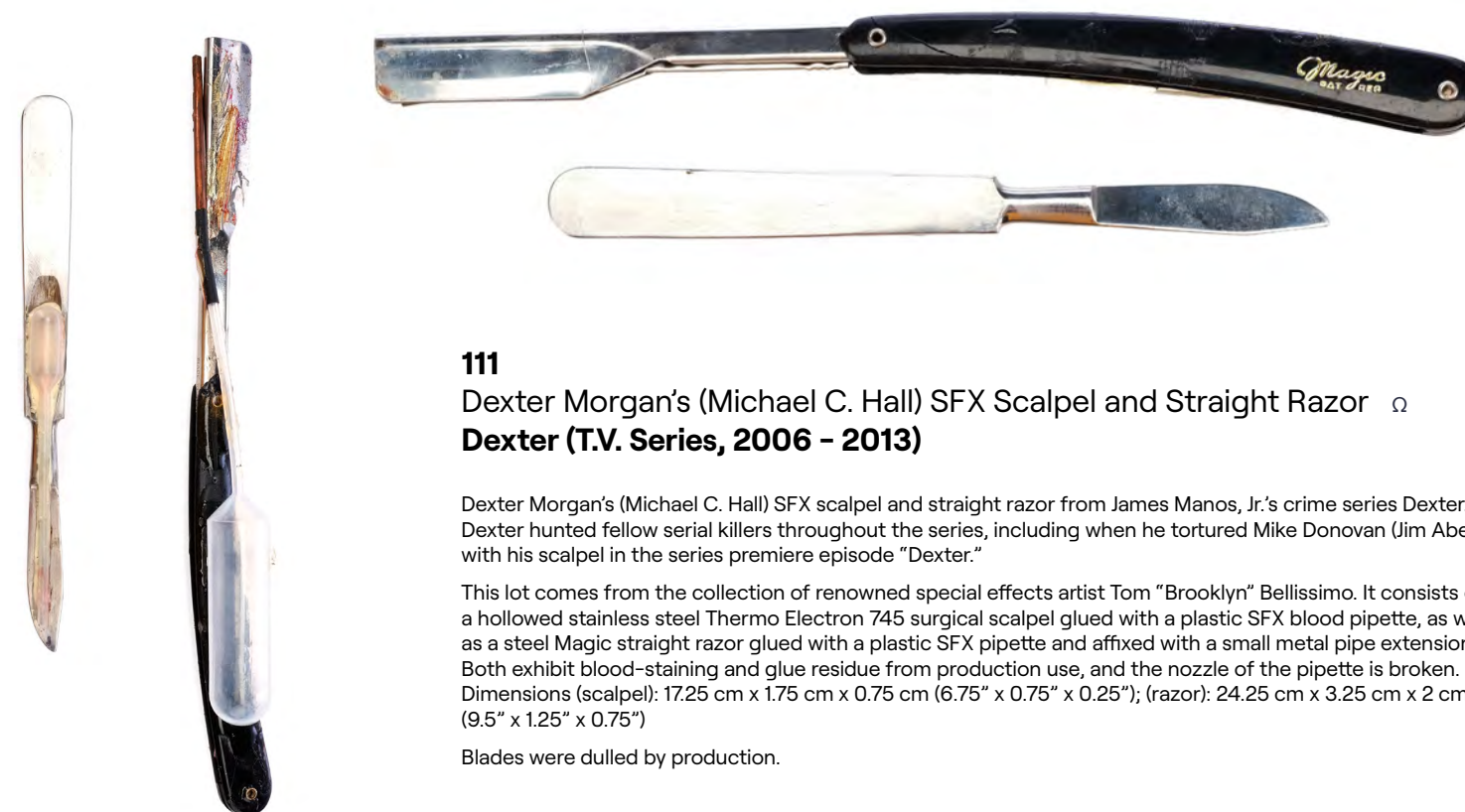

111
Dexter Morgan's (Michael C. Hall) SFX Scalpel and Straight Razor Ω
Dexter (T.V. Series, 2006 - 2013)

Dexter Morgan's (Michael C. Hall) SFX scalpel and straight razor from James Manos, Jr.'s crime series *Dexter*. Dexter hunted fellow serial killers throughout the series, including when he tortured Mike Donovan (Jim Abele) with his scalpel in the series premiere episode "Dexter."

This lot comes from the collection of renowned special effects artist Tom "Brooklyn" Bellissimo. It consists of a hollowed stainless steel Thermo Electron 745 surgical scalpel glued with a plastic SFX blood pipette, as well as a steel Magic straight razor glued with a plastic SFX pipette and affixed with a small metal pipe extension. Both exhibit blood-staining and glue residue from production use, and the nozzle of the pipette is broken. Dimensions (scalpel): 17.25 cm x 1.75 cm x 0.75 cm (6.75" x 0.75" x 0.25"); (razor): 24.25 cm x 3.25 cm x 2 cm (9.5" x 1.25" x 0.75")

Blades were dulled by production.

Estimate. £5,000 - 7,000



112
John McClane's (Bruce Willis)
Stunt MP5 Submachine Gun M
Die Hard (1988)

John McClane's (Bruce Willis) stunt MP5 submachine gun from John McTiernan's action film Die Hard. McClane took the firearm from a dead member of Hans Gruber's (Alan Rickman) crew and used it to clear the Nakatomi Tower rooftop of hostages, before taking a shortcut downstairs via the use of a firehose. The weapon is made of black rubber and features a black strap. It is accompanied by a letter of authenticity from property master Tommy Tomlinson. Dimensions: 50 cm x 6 cm x 25 cm (19 3/4" x 2 1/4" x 9 3/4")

Restricted ownership; see replica firearm notice in the Buyer's Guide.

Estimate. £8,000 - 12,000



113
John McClane's (Bruce Willis)
Screen-matched Costume M
Die Hard With A Vengeance (1995)

John McClane's (Bruce Willis) screen-matched costume from John McTiernan's action-thriller sequel Die Hard with a Vengeance. McClane wore his costume throughout the film, though it became more damaged and distressed as the action intensified.

The placement of some of the markings on the trousers screen match them to the scene in which McClane and Zeus (Samuel L. Jackson) solved the water jug task. There are also marks and staining on the back of the vest that screen match to the moment McClane searched henchmen Mischa (Mischa Hausserman) and Erik's (Phil Theis) bodies near their wrecked truck. The minor distressing on the shirt indicates it was used earlier in the film, before McClane jumped on the train.

The costume consists of a beige-and-white plaid cotton Barneys New York button-up shirt (size "M"); an off-white tank top; and a pair of khaki Ralph Lauren chinos. Also included is a wardrobe tag, on which the film's title is handwritten alongside "Bruce Willis, Plaid Shirt, White Tank Top, Khaki Pants, Green + White Boxers". The lot exhibits additional staining and wear from production use.

Estimate. £10,000 - 15,000



114
Zeus Carver's (Samuel L. Jackson)
Screen-matched Glasses M
Die Hard With A Vengeance (1995)

Zeus Carver's (Samuel L. Jackson) screen-matched glasses from John McTiernan's action sequel Die Hard with a Vengeance. Zeus wore his half-rim glasses throughout the film and they match the pair seen on screen through the tortoiseshell pattern on the frame. The glasses are manufactured by Dakota Smith and feature clear prescription-free lenses and a thin black neck cord. Dimensions (folded): 2.5 cm x 15 cm x 4.5 cm (1" x 6" x 1 3/4")

Estimate. £3,000 - 5,000



115
Zeus Carver's (Samuel L. Jackson) Costume M
Die Hard With A Vengeance (1995)

Zeus Carver's (Samuel L. Jackson) costume from John McTiernan's action-thriller sequel Die Hard with a Vengeance. Zeus wore his costume throughout the film, and different versions were created to demonstrate its gradual degradation as the action intensified. The shirt features a torn right sleeve and blood stains, indicating that this version was used after Zeus was slashed with a knife, while saving John McClane (Bruce Willis) from a gang in Harlem.

This costume consists of a cream Saks Fifth Avenue shirt (size 16"-36"), and a pair of dark grey cotton twill trousers (size 36L). Both the shirt and trousers feature "Zeus" handwritten in black pen on their interior labels. The costume exhibits minor staining from production use.

Estimate. £3,000 - 5,000



116
 Danny Torrance's (Ewan McGregor) Axe Ω
Doctor Sleep (2019)

Danny Torrance's (Ewan McGregor) axe from Mike Flanagan's supernatural horror sequel Doctor Sleep. Danny carried his axe as he fought against Rosie the Hat (Rebecca Ferguson) at the Overlook hotel during the film's climax.

McGregor specifically requested lightweight axes be made for him to carry, so the weapon is made of rubber, hand-painted to look like a wooden handle and a shiny steel axe head. The axe is accompanied by a letter of authenticity from the film's property master Scott Nifong. Dimensions: 92 cm x 3.5 cm x 30 cm (36 1/4" x 1 1/2" x 11 3/4")

Estimate. £8,000 - 12,000



117
 Training Sling Ring †Δ
Doctor Strange (2016)

A training sling ring from Scott Derrickson's superhero film Doctor Strange. Sorcerers-in-training used sling rings while practising at Kamar-Taj. The brass ring features two loops for fingers and has intricate brass detailing. It has been intentionally distressed to appear well used. Dimensions: 1 cm x 7 cm x 3 cm (1/4" x 2 3/4" x 1 1/4")

Estimate. £1,000 - 1,500



118
 Doctor Strange's (Benedict Cumberbatch) Sling Ring M
Doctor Strange (2016)

Doctor Strange's (Benedict Cumberbatch) sling ring from Scott Derrickson's superhero film Doctor Strange. Strange used his sling ring to create portals and travel around the world.

The metal ring has been intentionally distressed to look ancient and well used. It was originally donated by Cumberbatch to a charity auction raising money for the Disasters Emergency Committee and their work in Ukraine, and is accompanied by a handwritten note from Cumberbatch's management which reads, "With thanks & best wishes on behalf of Benedict", plus a printout of the original auction. Dimensions: 8 cm x 1.5 cm x 4.5 cm (3 1/4" x 1/2" x 1 3/4")

Estimate. £10,000 - 15,000



Photo 12 / Alamy Stock Photo

IN AID OF
BBC
CHILDREN
IN NEED

Lots 119 - 125 are being auctioned to raise funds for BBC Children In Need, a British charity committed to positively changing the lives of children and young people across the UK and on their behalf. All assets have been donated by BBC/BBC Studios Productions Limited direct from the show. A percentage of the final hammer price of these Auction Items will benefit BBC Children in Need (charity number 802052 in England & Wales and SC039557 in Scotland.) BBC Children in Need, Pudsey Bear and Blush are trade marks of the BBC and are used under licence. Additional lots from the collection can be found on Day 3 of the auction.



119
 BBC Children In Need Collection:
 The 12th Doctor's (Peter Capaldi)
 Coat †
**Doctor Who (T.V. Series,
 2005-Present)**

The 12th Doctor's (Peter Capaldi) coat from the BBC sci-fi series Doctor Who. The Doctor wore two different styles of his navy blue Crombie-style quarter-length coat during series 8 and series 9, as well as in promotional photographs. This style of Crombie was designed in series 8, under the supervision of costume designer Howard Burden, and features a three-button closure, five cuff buttons and a red and blue silk lining. The coat was bespoke-made and tailored for Capaldi in the role and has no size labelling.

Estimate. £2,000 - 3,000



120
 BBC Children In Need Collection:
 Full-Size Light-up New Paradigm Eternal Dalek †
Doctor Who (T.V. Series, 2005-Present)

A light-up New Paradigm Eternal Dalek from BBC TV series Doctor Who. The New Paradigm were first introduced in the Season 5 episode "Victory of the Daleks", in which the Doctor (Matt Smith) uncovered a plot to recreate the Dalek species during World War II. These new Daleks were much bulkier than their predecessors and introduced a colour-coded hierarchy.

The yellow-coloured Dalek, known as the Eternal, also appeared in the Season 5 episode "The Pandorica Opens" alongside a Supreme Dalek and a Drone Dalek, when the Doctor was locked away in the Pandorica.

The Dalek is made predominantly of moulded fibreglass and resin with medium-density fibreboard collar pieces and interior. It is painted yellow, with a silver-coloured metal eye stalk; a gun stick; an extendable metal arm; black sense globes on its lower half; and a grey midsection. The collar pieces are painted matt grey, and there is a small red button protruding from the back of the neck, which illuminates the Dalek's two dome lights. The sense globes and yellow paint finish exhibit scuffing, some components are missing from the two arms, and minor sympathetic restoration has been undertaken. Dimensions: 149 cm x 93 cm x 190 cm (58 1/2" x 36 1/2" x 74 3/4")

A percentage of the final hammer price of this lot will benefit BBC Children in Need (charity number 802052 in England & Wales and SC039557 in Scotland.) BBC Children in Need, Pudsey Bear and Blush are trade marks of the BBC and are used under licence.

Contains electronics; see electronics notice in the Buyer's Guide.

Special shipping required: see special shipping notice in the Buyer's Guide.

Estimate. £6,000 - 8,000



121
 BBC Children In Need Collection:
 Full-Size Light-up New Paradigm Strategist Dalek †
Doctor Who (T.V. Series, 2005-Present)

A light-up New Paradigm Strategist Dalek from BBC sci-fi series Doctor Who. The New Paradigm were first introduced in the Season 5 episode "Victory of the Daleks", in which the Doctor (Matt Smith) uncovered a plot to recreate the Dalek species during World War II. These new Daleks were much bulkier than their predecessors and introduced a colour-coded hierarchy.

The blue-coloured Dalek, known as the Strategist, also appeared in the Season 7 episode "Asylum of the Daleks", although the casing colour was changed to a darker blue, like this example.

The Dalek is made predominantly of moulded fibreglass and resin with medium-density fibreboard collar pieces and interior. It is painted blue, with a silver-coloured metal eye stalk; a gun stick; an extendable plunger rod; silver sense globes on its lower half; and a grey midsection. The collar pieces are painted metallic grey, and there is a small red button protruding from the back of the neck, which illuminates the Dalek's two dome lights. The casing and sense globes display scuffing, and chips on the lower collar piece have exposed the fibreglass. Minor sympathetic restoration has been undertaken on the lot. Dimensions: 153 cm x 93 cm x 190 cm (60 1/4" x 36 1/2" x 74 3/4")

Contains electronics; see electronics notice in the Buyer's Guide.

Special shipping required: see special shipping notice in the Buyer's Guide.

Estimate. £8,000 - 12,000



122
BBC Children In Need Collection: Full-Size
New Paradigm Supreme Dalek +
Doctor Who (T.V. Series, 2005-Present)

A New Paradigm Supreme Dalek from BBC sci-fi series Doctor Who. The New Paradigm were first introduced in the Season 5 episode "Victory of the Daleks", in which the Doctor (Matt Smith) uncovered a plot to recreate the Dalek species during World War II. These new Daleks were much bulkier than their predecessors and introduced a colour-coded hierarchy.

The white-coloured Daleks, known as the Supreme, appeared in multiple episodes, including Season 5's "The Pandorica Opens" and "The Big Bang", and the Season 7 episode "Asylum of the Daleks".

The Dalek is made predominantly of moulded fibreglass and resin with medium-density fibreboard collar pieces and interior. It is painted white, with grey sense globes on its lower half and a matching grey midsection and collar pieces. The head, featuring one non-functioning dome light, is loose, as are the four collar pieces. There is minor damage to the collar pieces and scuffing on the white paint finish. Some components are missing, and minor sympathetic restoration has been undertaken. Dimensions: 147 cm x 95 cm x 183 cm (57 3/4" x 37 1/2" x 72")

Special shipping required: see special shipping notice in the Buyer's Guide.

Estimate. £4,000 - 6,000



123
BBC Children In Need Collection: Full-Size
Battle-damaged New Paradigm Strategist Dalek +
Doctor Who (T.V. Series, 2005-Present)

A battle-damaged New Paradigm Strategist Dalek from the production of BBC sci-fi series Doctor Who. The New Paradigm were first introduced in the Season 3 episode "Victory of the Daleks", in which the Doctor (Matt Smith) uncovered a plot to recreate the Dalek species during World War II. These new Daleks, named the New Paradigm, were much bulkier than their predecessors and introduced a colour-coded hierarchy. While this particular battle-damaged Dalek, known as a Strategist, is not clearly seen on screen, reference to destroyed New Paradigm Daleks is made in several literary and video-game spin-offs.

The Dalek is made predominantly of moulded fibreglass and resin with medium-density fibreboard collar pieces and interior. It is painted blue with grey bosses - or "sense globes" - on its lower half, a matching grey midsection, and metallic grey collar pieces.

The Dalek shows paint wear and damage from its time in previous storage facilities, in addition to heavy production-applied distress. However, it has had some sympathetic restoration and assembly. Dimensions: 146 cm x 93 cm x 184 cm (57 1/2" x 36 1/2" x 72 1/2")

Special shipping required: see special shipping notice in the Buyer's Guide.

Estimate. £6,000 - 8,000



124
BBC Children In Need Collection: Full-Size
Battle-damaged New Paradigm Drone Dalek +
Doctor Who (T.V. Series, 2005-Present)

A battle-damaged New Paradigm Drone Dalek from the production of BBC sci-fi TV series Doctor Who. The New Paradigm were first introduced in the Season 3 episode "Victory of the Daleks", in which the Doctor (Matt Smith) uncovered a plot to recreate the Dalek species during World War II. These new Daleks, named the New Paradigm, were much bulkier than their predecessors and introduced a colour-coded hierarchy.

Due to fans' mixed opinions of their design, the New Paradigm were ret-conned and their look altered, making this variation a rare find. While this particular battle-damaged Dalek, known as a Drone, is not clearly seen on screen, reference to destroyed New Paradigm Daleks is made in several literary and video-game spin-offs.

The Dalek is made predominantly of moulded fibreglass and resin with medium-density fibreboard collar pieces and interior. It is painted red, with grey bosses - or "sense globes" - on its lower half, with a matching grey midsection and metallic grey neck pieces. The Dalek shows paint wear and damage from its time spent in previous storage facilities, in addition to heavy production-applied distress. However, it displays some sympathetic restoration. Dimensions: 153 cm x 93 cm x 190 cm (60 1/4" x 36 1/2" x 74 3/4")

Special shipping required: see special shipping notice in the Buyer's Guide.

Estimate. £6,000 - 8,000



125
BBC Children In Need Collection: Full-Size
Screen-matched Light-up Battle-damaged
New Paradigm Dalek +
Doctor Who: The Asylum Of The Daleks (T.V. Series, 2012)

A screen-matched light-up battle-damaged New Paradigm Dalek from BBC sci-fi series Doctor Who. In the Season 7 episode "The Asylum of the Daleks", several Daleks became damaged and melted after the Doctor (Matt Smith) caused a decaying Dalek to self-destruct. The placement of the scuffs and marks on the body screen match the lot to the scene where Rory (Arthur Darvill) ran into a room full of damaged Dalek casings after the explosion. It can also be matched to a shot in behind-the-scenes footage of the episode.

The Dalek is made of moulded fibreglass and resin with a medium-density fibreboard interior. It is painted in shades of white, with grey added to represent charring, and features grey sense globes and a metal arm. Appearing through one of the cracks on the Dalek's skirt are some warm-white rope lights, which illuminate via an attached plug. The separate head has several non-functioning cables and electronics on its interior. The lot is heavily distressed to appear battle damaged, and some minor sympathetic restoration has been undertaken. Dimensions: 155 cm x 95 cm x 163 cm (61" x 37 1/2" x 64 1/4")

Contains electronics; see electronics notice in the Buyer's Guide.

Special shipping required: see special shipping notice in the Buyer's Guide.

Estimate. £3,000 - 5,000



126
 Universal Studios E.T. Display 
E.T. Adventure

An E.T. display created by Universal Creative for E.T. Adventure. Developed in collaboration with Steven Spielberg and staged at Universal Studios Florida, Hollywood, and Japan, the attraction took attendees through E.T.'s Green Planet homeworld and restaged the flying bicycle sequence from E.T. the Extra-Terrestrial. E.T. Adventure was removed from Universal Studios Hollywood in 2003 and Japan in 2009.

This static, ornately detailed fibreglass statue is hand-painted to appear brown, inset with large blue plastic eyes, and dressed with a blue cotton flannel robe modelled after E.T.'s robe from the film. It comes mounted to a wooden display base. The fibreglass exhibits some fracturing, including around the mouth, and paint scuffing throughout from use. Dimensions: 114.5 cm x 33 cm x 99 cm (45" x 13" x 39")

Estimate. £4,000 - 6,000

127
 Santa's (Ed Asner) Light-up Scaled Sleigh Dashboard with Spirit Clausometer 
Elf (2003)

Santa's (Ed Asner) light-up, scaled sleigh dashboard with a Spirit Clausometer from Jon Favreau's Christmas movie Elf. Jovie (Zooey Deschanel) started a sing-along to raise the Clausometer on Santa's sleigh after Buddy (Will Ferrell) lost his Christmas spirit.

This dashboard was custom-made by the SFX team for shots of the fully-operational sleigh at a smaller scale in order to make Buddy appear oversized. It features a panel of chrome-plated buttons and gauges, including a "Spirit Clausometer," a pressure gauge, and buttons labelled "Ho Ho Ho," inset into a polished wooden compartment. Following production, electronics on the reverse were switched out by SFX crew with a more automated system which illuminates buttons and raises gauges when connected to an AC outlet. Several lights are dimming and the wood exhibits scratches from production use. Dimensions: 58.5 cm x 18 cm x 28 cm (23" x 7" x 11")

Contains electronic components; see notice in the Buyer's Guide.

Estimate. £5,000 - 7,000

58.5 cm (23")

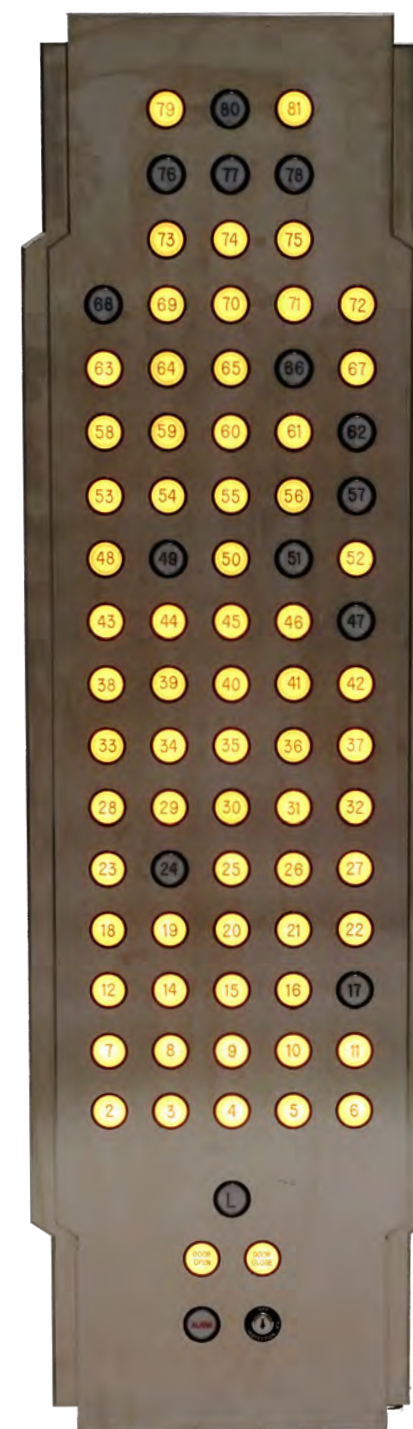

128
 Light-up Empire State Building Elevator Button Panel 
Elf (2003)

A light-up Empire State Building elevator button panel from Jon Favreau's Christmas movie Elf. After he witnessed an elevator button lighting up, Buddy (Will Ferrell) was overcome with excitement and pushed every button to light more up.

Custom-made by SPFX Coordinator Tony Lazarowich's team, this lot consists of a metal elevator panel with working buttons and individual plugs and cables rigged to each light. The back bottom of the panel features a written label for "Tony SFX." The panel requires a 12V car battery to operate the lights. This lot exhibits burnt out bulbs in buttons 80, 76, 78, 49, 51, 24, 17, L, and Alarm. Dimensions: 38.25 cm x 131 cm x 7.75 cm (15" x 51.5" x 3")

Contains electronics; see electronics notice in the Buyer's Guide.

Estimate. £4,000 - 6,000



129
 Buddy's (Will Ferrell) SFX Jack-in-the-Box 
Elf (2003)

Buddy's (Will Ferrell) SFX Jack-in-the-Box from Jon Favreau's Christmas movie Elf. Buddy tested frightening Jack-in-the-Box toys in Santa's (Ed Asner) workshop. One of them later appeared on Santa's sleigh.

This Jack-in-the-Box was customised with an internal remote-firing system by the SFX team to control the padded felt Jack's launch time during the workshop and sleigh scenes. The Jack comes inside a colourful tin box affixed with a red-topped crank which operates a music box on the interior. Due to its adjustments, the lid must be lifted for the Jack to launch, and the remote-firing mechanism was removed following production. The box exhibits scratching and scuffing around its edges from use. Dimensions: 15.25 cm x 15.25 cm x 16.5 cm (6" x 6" x 6.5")

Contains mechanical components; see notice in the Buyer's Guide.

Estimate. £4,000 - 6,000



130
Snake Plissken's (Kurt Russell) Hero Costume M
Escape From L.A (1996)

SNAKE PLISSKEN'S (KURT RUSSELL) HERO COSTUME FROM JOHN CARPENTER'S DYSTOPIAN SCI-FI SEQUEL ESCAPE FROM L.A. SNAKE WORE HIS COSTUME THROUGHOUT THE FILM AS HE ATTEMPTED TO RETRIEVE A SUPER-WEAPON FROM THE RUINED ISLAND OF LOS ANGELES.

ALTHOUGH PRESENTED IN THE FILM AS A TOP AND A PAIR OF TROUSERS, THE COSTUME IS ACTUALLY A BLACK ELASTICATED JUMPSUIT WITH A MESH TOP LAYER. "KURT HERO" IS HANDWRITTEN ON A LABEL IN THE BACK, NEXT TO THE ZIP. VELCRO STRIPS ARE ADHERED AROUND THE WAIST AND THIGHS, WHICH WOULD HAVE SECURED SNAKE'S BELT AND THIGH HOLSTERS, AND THERE IS AN ELASTICATED STIRRUP AT THE END OF EACH LEG. THE JUMPSUIT'S COLOURING HAS DEGRADED AND FLAKED AWAY OVER TIME.

Estimate. £6,000 - 8,000



131
Miller's (Laurence Fishburne) Costume Ω
Event Horizon (1997)

CAPT. MILLER'S (LAURENCE FISHBURNE) COSTUME FROM PAUL W.S. ANDERSON'S SCI-FI HORROR THRILLER EVENT HORIZON. MILLER WORE HIS JUMPSUIT AS HE COMMANDED THE LEWIS AND CLARK ON ITS ILL-FATED MISSION TO RESCUE SURVIVORS OF THE EVENT HORIZON, A SHIP MISSING FOR SEVEN YEARS.

THIS COSTUME CONSISTS OF A BROWN LEATHER BOMBER-STYLE JACKET; AN OLIVE GREEN JUMPSUIT WITH MULTIPLE ZIPPED POCKETS MARKED "FISHBURNE" ON THE INTERIOR; A MOSS GREEN COTTON T-SHIRT; A METAL-CLAD REPLICATED NECKLACE AND PAIR OF BLACK COTTON AND RUBBER REPLICATED SHOES. THE JACKET AND JUMPSUIT FEATURE SEVERAL PRODUCTION-MADE PATCHES, WHILE THE T-SHIRT FEATURES THE CHARACTER'S VITAL INFORMATION ON THE FRONT. IT EXHIBITS SIGNS OF WEAR AND STAINING ON THE JACKET, JUMPSUIT, AND T-SHIRT.

Estimate. £3,500 - 5,500

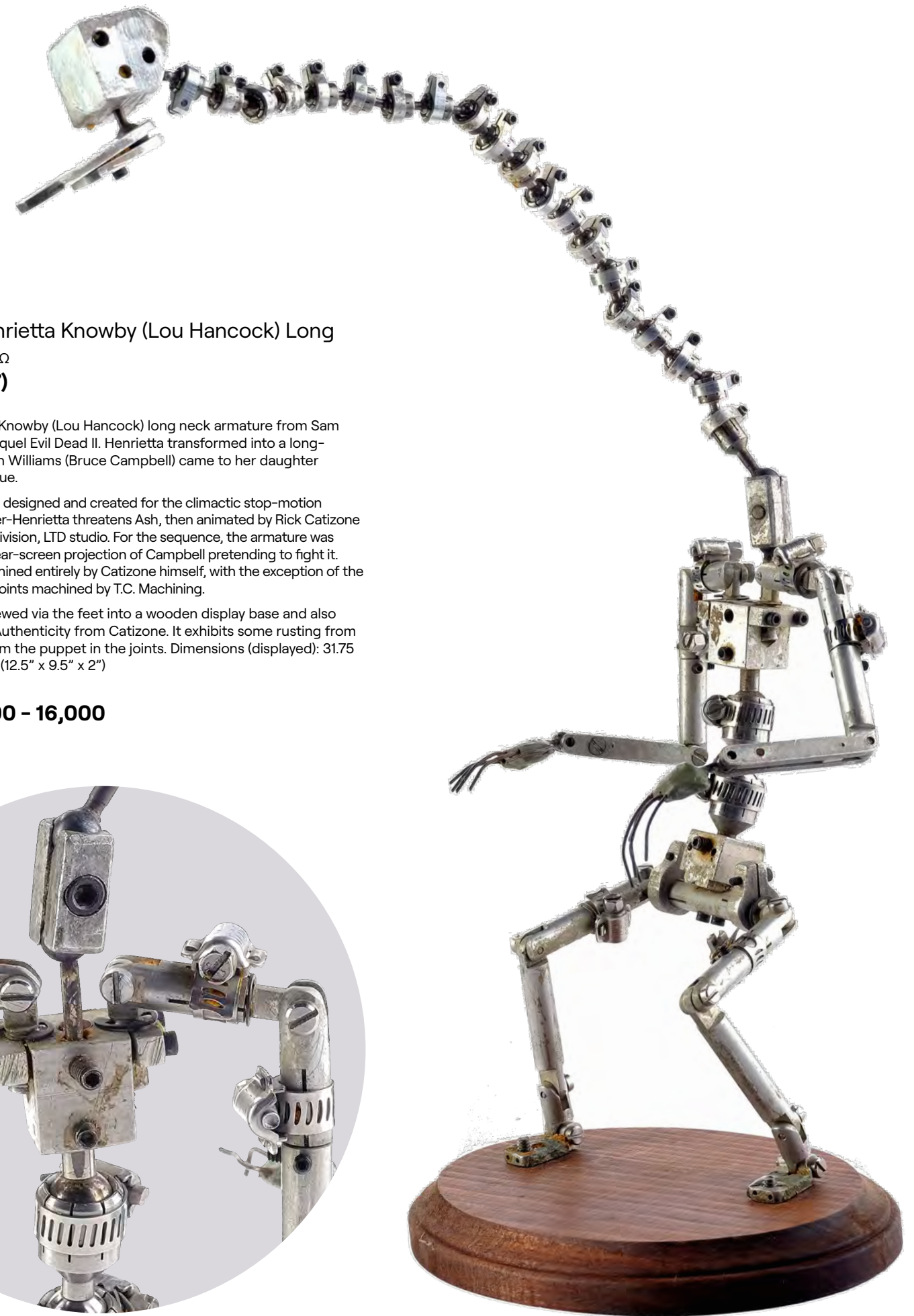

132
Stop-Motion Henrietta Knowby (Lou Hancock) Long Neck Armature Ω
Evil Dead II (1987)

A STOP-MOTION HENRIETTA KNOWBY (LOU HANCOCK) LONG NECK ARMATURE FROM SAM RAIMI'S HORROR COMEDY SEQUEL EVIL DEAD II. HENRIETTA TRANSFORMED INTO A LONG-NECKED MONSTER AFTER ASH WILLIAMS (BRUCE CAMPBELL) CAME TO HER DAUGHTER ANNIE'S (SARAH BERRY) RESCUE.

THIS SPECIFIC ARMATURE WAS DESIGNED AND CREATED FOR THE CLIMACTIC STOP-MOTION SEQUENCE IN WHICH MONSTER-HENRIETTA THREATENS ASH, THEN ANIMATED BY RICK CATIZONE IN HIS PITTSBURGH-BASED ANIVISION, LTD STUDIO. FOR THE SEQUENCE, THE ARMATURE WAS PHOTOGRAPHED AGAINST A REAR-SCREEN PROJECTION OF CAMPBELL PRETENDING TO FIGHT IT. MADE OF METAL, IT WAS MACHINED ENTIRELY BY CATIZONE HIMSELF, WITH THE EXCEPTION OF THE SPECIAL "COLLET STYLE" NECK JOINTS MACHINED BY T.C. MACHINING.

THE ARMATURE COMES SCREWED VIA THE FEET INTO A WOODEN DISPLAY BASE AND ALSO INCLUDES A CERTIFICATE OF AUTHENTICITY FROM CATIZONE. IT EXHIBITS SOME RUSTING FROM AGE AND FOAM RESIDUE FROM THE PUPPET IN THE JOINTS. DIMENSIONS (DISPLAYED): 31.75 CM X 24.25 CM X 5.25 CM (12.5" X 9.5" X 2")

Estimate. £12,000 - 16,000



133
 Stop-Motion Ash Williams (Bruce Campbell)
 Hand Armature Ω
Evil Dead II (1987)

A stop-motion Ash Williams (Bruce Campbell) hand armature from Sam Raimi's horror comedy *Evil Dead II*. Ash cut off his possessed hand with a chainsaw, then shot it as it taunted him.

This specific armature was designed and created for the stop-motion sequence in which Ash's hand crosses the room, drums its finger, and triggers a rat trap, then animated by Rick Catizone's Pittsburgh-based Anivision, LTD studio. Made entirely of metal, it features articulated digits and comes mounted to a wooden display plaque. Also included is a Certificate of Authenticity from Catizone. It exhibits some rusting from age. Dimensions (displayed): 29.25 cm x 21.75 cm x 9 cm (11.5" x 8.5" x 1")

Estimate. £10,000 - 15,000

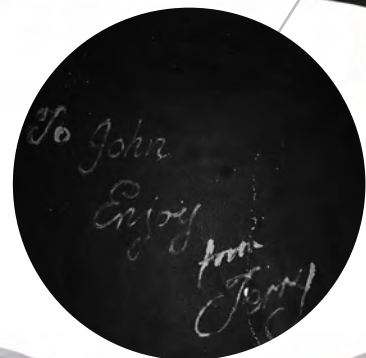

134
 Sir John Boorman's Personally Received Merlin's
 (Nicol Williamson) Production Gift Helmet Ω
Excalibur (1981)

A Senior crew gift of Merlin's (Nicol Williamson) helmet personally gifted to Sir John Boorman from the production of his fantasy epic *Excalibur*. Merlin (Nicol Williamson) wore his helmet throughout the film as he guided and advised Arthur Pendragon (Nigel Terry).

This helmet is one of a very small number made as senior executive gifts by celebrated British armorer Terry English, while he also created the production-used helmet. Its imaginative design was fundamental in helping Williamson create the character, as he was reluctant to shave his head bald for filming.

Hand beaten from aluminium, the skullcap-style helmet was custom-made for the actor. It is polished to a smooth shine and adorned with a silver-coloured emblem on the forehead. The interior is painted black with a handwritten inscription in silver-coloured ink reading, "To John, Enjoy, From Terry" and faded reference number. English's signature "T" stamp is below the left ear. The helmet remains highly polished with some very light surface tarnishing. Dimensions: 25 cm x 16 cm x 20 cm (10" x 6" x 8")

This lot comes directly from the personal collection of director Sir John Boorman and is accompanied by a letter from him confirming its authenticity.

Estimate. £6,000 - 8,000



135
 Perceval's (Paul Geoffrey) Screen-matched Holy Grail Ω
Excalibur (1981)

A screen-matched Holy Grail from John Boorman's fantasy epic *Excalibur*. After the ailing King Arthur (Nigel Terry) dispatched his knights to search for the Holy Grail, it was eventually found by Perceval (Paul Geoffrey) and brought to Camelot. The unique hand-etched scale pattern around its rim screen-matches the Grail to the one Perceval handed Arthur to drink from.

While designing the Grail, Boorman and art director Robert Pratt visited the Victoria and Albert Museum in London for inspiration, and decided upon a goblet with a highly reflective surface. The Grail is made of hand-beaten aluminium, and its individual beating marks are visible inside the cup. Its exterior, meanwhile, features exquisite hand-etched details around the base and rim. The Grail has tarnished over time, and the interior - which held a liquid resembling red wine during filming - has darkened further. Dimensions: 18 cm x 18 cm x 20 cm (7" x 7" x 8")

This lot comes directly from the personal collection of director Sir John Boorman and is accompanied by a letter from him confirming its authenticity.

Estimate. £8,000 - 12,000



136
Mordred's (Robert Addie) Screen-matched Helmet Ω
Excalibur (1981)

Mordred's (Robert Addie) golden helmet from John Boorman's fantasy epic Excalibur. The grown-up Mordred wore his armour in battle against his father King Arthur (Nigel Terry). Markings and imperfections on the face match the helmet to the one seen on screen.

Previously thought to be lost since production, this fibreglass helmet was revealed to be in the possession of the film's Academy Award®-nominated director Sir John Boorman.

It is painted to resemble solid gold and features a chinstrap and a foam-padded interior. The helmet has some wear from production use and age, including small cracks, discolouration and chips to the paintwork. In addition, a liquid has left a green stain down the middle of the face. Dimensions: 26 cm x 24 cm x 26 cm (10 ¼" x 9 ½" x 10 ¼")

This lot comes directly from Boorman's personal collection and is accompanied by a letter from Boorman confirming its authenticity.

Estimate. £10,000 - 15,000



137
Light-up Maquette of Pilot at Moya's Console M
Farscape (T.V. Series, 1999-2003)

A light-up maquette of Pilot (Lani John Tupu) at Moya's console from the production of sci-fi TV series Farscape. Pilot was a multi-limbed creature who was biologically connected to Moya, a living, Leviathan ship, acting as her voice and pilot.

This large maquette is made predominantly of resin and vacuum-formed plastic. It is hand-painted and intentionally distressed to look old, worn and living. The screens in front of Pilot illuminate when powered with a 9V battery, and there is a switch hidden in the back. One of Pilot's arms is missing and there are a couple of small chips and areas of paintwear. The maquette is displayed on a black piece of wood. Dimensions: 60 cm x 58 cm x 33 cm (23 ½" x 22 ¾" x 13")

Contains electronics; see electronics notice in the Buyer's Guide.

Estimate. £4,000 - 6,000



138
Leeloo's (Milla Jovovich) Orange Suspenders Ω
Fifth Element, The (1997)

Leeloo's (Milla Jovovich) orange suspenders from Luc Besson's sci-fi adventure The Fifth Element. Leeloo wore her signature suspenders throughout the film after picking them out from a selection of Father Vito Cornelius' (Ian Holm) clothes.

Envisioned by celebrated costume and fashion designer Jean-Paul Gaultier specifically for Jovovich, these form-fitting, futuristic suspenders are cast from orange silicone. They feature multiple circular cutouts and straps which run from the shoulders between the legs and up the back. The silicone exhibits scuffing and small tears throughout from production wear, including between the holes at the legs.

Estimate. £4,000 - 6,000

139
Screen-matched Police Officer Costume +
Fifth Element, The (1997)

A screen-matched police officer costume from Luc Besson's sci-fi adventure The Fifth Element. Police officers featured throughout the film as they hunted the alien escapee Leeloo (Milla Jovovich) and her protector Korben Dallas (Bruce Willis) and policed the rough streets of The Federated Territories' capital, New York City.

The circle emblem on the chest armour screen-matches the costume to the officer in the passenger seat of the vehicle that crashed into a McDonald's truck while the police chased Korben and Leeloo.

Exhibiting a futuristic appearance, the costume comprises a fibreglass helmet (labelled "45, Chris"); a ribbed balaclava; a long-sleeved underlayer top with a zip running down the front; a padded cotton ribbed overvest with attached sleeves and shoulder armour components (labelled "Costume 6"); black foam shoulder padding with a strip of Velcro on one side; a plastic chest armour piece which displays a light-up marbled circle panel; a pair of black Lycra shorts with elasticated braces (size 3); two full-length ribbed leg pads; a plastic codpiece; a pair of black leather gloves with metal spike detailing (size L); and black distressed leather boots with detachable metal toe plates.

Two transparent blue visors adorn the front of the helmet, to which various white "Police" decals are adhered. Attached to the helmet is an animatronic cable that would have enabled the visors to move up and down. The plastic components of the costume have been finished in a faux-bronze colour. A battery pack with various cables is situated on the back of the overvest and connects to a cable within the chest armour. Internal electronics are fitted behind the circle panel on the chest armour and a red light is located on the left shoulder, both powered by a 12-volt DC power supply.

Accompanying the costume is a dense rubber riot shield, a rubber truncheon and a blue-and-faux-silver stunt gun. The shield displays protruding rubber spikes and a yellow "Police" emblem on the front. Engraved text adorns both sides of the gun and a magnet is adhered to the underside, allowing the weapon to be attached to the costume's left shoulder.

The animatronic cable on the helmet no longer functions, and some of the decals have begun to peel away on the right side. Signs of production use are present on the lot, including minor paint wear, dirt marks on the overvest, the rubber grill on the top of the shield has become damaged and the faux-bronze armour pieces have been intentionally distressed to create a worn appearance.

Contains electronics; see electronics notice in the Buyer's Guide.

Estimate. £10,000 - 15,000



140
Leeloo's (Milla Jovovich) Severed Hand Ω
Fifth Element, The (1997)

Leeloo's (Milla Jovovich) severed hand from Luc Besson's sci-fi adventure The Fifth Element. The government used biotechnology to recreate Leeloo, the weapon and Fifth Element designed to defeat the great evil, from a hand found in the wreckage of a Mondoshawan ship.

This gauntlet-style hand is made of cast resin painted brass-colour and dry-brushed with black paint by production to appear aged and distressed. A removable resin handle painted grey to resemble stone is grasped in the hand, and the fingertips feature the four symbols of the elements. Also included is a loose piece of the handle. The hand exhibits cracking throughout, noticeably around the wrist, and paint chipping from production use and age. Dimensions: 25.5 cm x 12.75 cm x 10.25 cm (10" x 5" x 4")

Estimate. £10,000 - 15,000

141
Mangalore Head and Hands Ω
Fifth Element, The (1997)

A Mangalore head and hands from Luc Besson's sci-fi adventure The Fifth Element. Hired by Zorg (Gary Oldman), the alien Mangalores pursued Leeloo (Milla Jovovich) and Korben Dallas (Bruce Willis) throughout the film in search of the Mondoshawan elemental stones.

Made of foam latex painted in shades of mottled brown, the detailed mask exhibits two eye holes and a set of intentionally discoloured teeth. The mask is adhered to a champagne stretch-fabric collar, with plastic tubing around the bottom to add structure.

The one-piece foam-latex gloves feature raised vein-like detailing and four large fingers complete with nails. Presented on custom-made displays, the lot shows paint wear and cracking, and some minor tears are present on the hands. The bottom edge of the foam latex has started to peel away from the collar. Dimensions (head, displayed): 38 cm x 34 cm x 55 cm (15" x 13 1/4" x 21 1/2"); (hands displayed): 20.5 cm x 36 cm x 25 cm (8" x 14 1/4" x 9 3/4")

Estimate. £5,000 - 7,000





142
 Ruby Rhod's (Chris Tucker)
 Blond Wig Ω
Fifth Element, The (1997)

Ruby Rhod's (Chris Tucker) blond wig from Luc Besson's sci-fi action film *The Fifth Element*. Interstellar radio presenter Ruby Rhod wore his blond wig when he first met Dallas (Bruce Willis) onboard the Fhloston Paradise space cruise ship.

The wig is constructed from tightly curled polyester hair shaped in a unicorn-esque horn, fixed on a stretchy mesh base. It features some remaining hairpins from production use and comes presented on a black mannequin head. Dimensions: 35 cm x 26 cm x 37 cm (14 1/4" x 7" x 10 1/4")

Estimate. £3,000 - 5,000



143
 The Narrator's (Edward Norton)
 Stunt Pistol M
Fight Club (1999)

The Narrator's (Edward Norton) stunt pistol from David Fincher's comedy thriller *Fight Club*. The Narrator (Edward Norton) stole a pistol from a corrupt officer while escaping a police station. He later used the gun to shoot himself in the mouth, ultimately killing his alter ego Tyler Durden (Brad Pitt).

The weapon is made of foam rubber and cast from a hero Smith & Wesson 4506, with the production numbers and manufacturer's stamps present on the frame and slide. It is finished in silver-coloured paint to resemble stainless steel, and the textured grip is painted black. The lot displays notable paint wear and some cracking, and is accompanied by a 20th Century Fox certificate of authenticity. Dimensions: 22 cm x 3.5 cm x 14.5 cm (8 3/4" x 1 1/4" x 5 3/4")

Restricted ownership; see replica firearm notice in the Buyer's Guide.

Estimate. £4,000 - 6,000

144
 The Narrator's (Edward Norton)
 Hero FURNI Catalogue Ω
Fight Club (1999)

The Narrator's (Edward Norton) hero FURNI catalogue from David Fincher's comedic thriller *Fight Club*. The interior decor-obsessed Narrator read his 1999 FURNI catalog on the toilet, saying, "Like so many others, I had become a slave to the IKEA nesting instinct."

This empty hero paper catalogue reads "FURNI: Affordable Design for Living" on its front with the mailing address for "Current Occupant, 3499 Pearson Street Unit 1749, Bradford 198320" printed on the reverse. It exhibits crease lines along the spine with a small piece ripped from the top back corner by production. Dimensions: 27.5 cm x 21.75 cm (10.75" x 8.5")

Estimate. £2,000 - 3,000



145
 Tyler Durden's (Brad Pitt) Jeans M
Fight Club (1999)

Tyler Durden's (Brad Pitt) jeans from David Fincher's satirical thriller *Fight Club*. Mysterious soap salesman Durden wore his striped jeans during a short scene in which he and the Narrator (Edward Norton) drunkenly hit golf balls outside his dilapidated house. The two actors were actually drunk at the time, and were hitting golf balls into the side of the production's catering truck.

These vintage flared jeans feature red and white vertical stripes and the word "Levi's" woven in white. A button and zip fly adorn the front, and the jeans display multiple pockets and belt loops. Signs of production use include minor wear, loose lines of threads and general fraying in places, notably on both of the hems. The lot is accompanied by a 20th Century Fox certificate of authenticity.

Estimate. £2,000 - 3,000

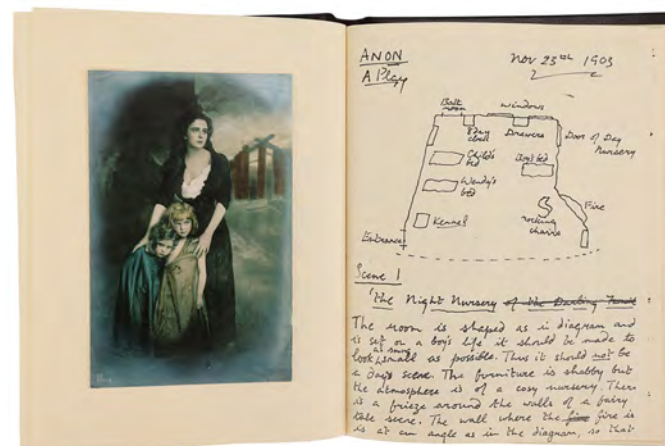
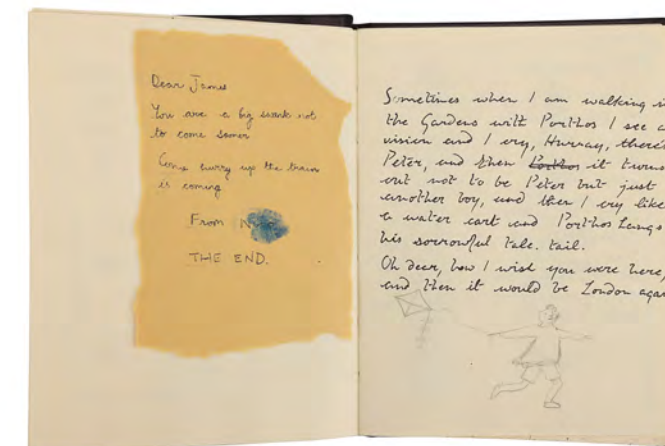
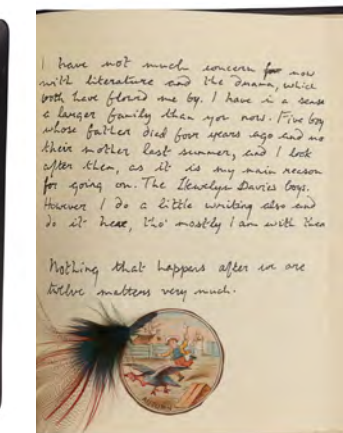

146
 J.M. Barrie's (Johnny Depp) Notebook M
Finding Neverland (2004)

J.M. Barrie's (Johnny Depp) notebook from Marc Forster's biographical drama *Finding Neverland*. Barrie wrote down story ideas in his notebook throughout the film.

The book is black and leather-bound, with gilded page edges. Many of the pages feature printed text, and some have pictures slipped between them. There are also two feathers, a pressed flower and a few handwritten pencil annotations. Some of the printed pages are misaligned. Dimensions: 19.5 cm x 15 cm x 2.5 cm (7 3/4" x 6" x 1")

Estimate. £4,000 - 6,000

147

Fraggle Puppet [†]
Fraggle Rock (TV Series, 1983-1987)

A Fraggle puppet from the classic children's TV series Fraggle Rock. The Fraggles were tiny humanoid creatures that lived on radishes and inhabited the natural caves within the titular peninsula. The series was conceived by the legendary Jim Henson, creator of The Muppets.

This Fraggle is one of a horde of unnamed background characters that followed Gobo, Mokey, Wembley and Red on assorted escapades. He can be seen in various episodes wearing different costumes, but his slightly wonky eyes remain consistent. The general Fraggle population came in a multitude of different sizes and colours. This one is vivid orange and is constructed from soft "Muppet material". His red hair is made from dyed feathers that give a lifelike bounce even with the slightest movement. A tag inside reads "Property of The Muppets" and has "Gaggle 12/82 'Pudgy Gold' Toronto Exhibit" handwritten in red pen.

The puppet was gifted to a senior crew member on completion of the final episode in 1987, and it sits on a custom-made display stand. Dimensions (display): 35 cm x 30 cm x 41 cm (13 3/4" x 11 3/4" x 15 3/4")

Estimate. £40,000 - 60,000



MARIO KIRNER COLLECTION

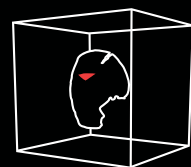

Friday the 13th
props museum

The following 11 lots come from the Friday the 13th Props Museum collection of Mario Kirner. The Museum was created as a private collection that showcased not only Jason's iconic hockey mask, but also a number of other movie props, costumes and additional materials that were used during the production of the Friday the 13th movies.

An avid contributor in the screen-used prop and costume collecting field for more than 20 years, Mario Kirner has been a dedicated in his work and efforts to help to transform what was once a niche hobby into a popular culture phenomenon. Mario is not just a collector, but a true historian and curator of all things Jason Voorhees and Friday the 13th, also publishing a book dedicated to showcasing the museum's content and their stories. Additional lots from the Mario Kirner collection can be found on Auction Day 3, see page 477.

148
Mario Kirner Collection: Jason Voorhees' (C.J. Graham) Screen-matched Hero Hockey Mask α
Friday The 13th Part VI: Jason Lives (1986)

Jason Voorhees' (C.J. Graham) screen-matched hero hockey mask from Tom McLoughlin's slasher sequel Friday the 13th Part VI: Jason Lives. Jason wore his trademark hockey mask throughout the film, after accidentally being resurrected by Tommy (Thom Mathews). Markings and paintwork on the mask screen-match it to the scene where Jason enters the lake and is seen underwater.

This particular mask was used for multiple stages of the production, but most notably in the film's second half, as it features bullet-hole damage. It was used for close-up shots and underwater stunts, and was also placed on the FX puppet used during the sequence where Jason is hit in the head with a motorboat propeller. The propeller scenes were mirrored on screen, so it appears Jason's mask was hit on the left side when, in fact, he was struck on the right side. This damage was worked into the mask design for the subsequent film, Friday the 13th Part VII: The New Blood.

This instalment in the franchise enjoyed a larger budget than previous productions, meaning that 12 versions of the mask could be created. Eight were used for earlier scenes in the film, while the remaining four featured a bullet hole in the forehead.

The hockey mask is made of clear acrylic, with brown-and-yellow epoxy spray-paint shades applied to the exterior, and a decorative red triangle emblem on the forehead. Intentional wear and distressing are applied, and a large section of the mask's left side is missing, representing the propeller damage. Three brown leather straps are adhered to the mask, and "7" is written in black marker on the inside. Remnants of glue and rubber from the FX puppet are still present on the interior, and the mask exhibits scratches and dried stage-blood markings from production use. The lot remains fragile and is accompanied by a certificate of authenticity signed by credited special effects make-up assistant William Forsthe. Dimensions: 26 cm x 26 cm x 10 cm (10 1/4" x 10 1/4" x 4")

Estimate. £40,000 - 60,000



149

Mario Kirner Collection:
Hunting Knife and Sheath 
Friday The 13th Part VI: Jason Lives (1986)

A knife and sheath from Tom McLoughlin's slasher sequel Friday the 13th Part VI: Jason Lives. Jason (C.J. Graham) wore his sheath by his hip and used his hunting knife to murder Cort (Tom Fridley) by stabbing it through his head. Only one knife was used for the production; it is made from aluminium and features a blade with a serrated edge, and a cross-hatched grip painted black. It fits into a leather sheath that comes with a whetstone. The knife and sheath exhibit areas of rusting and abrasions to the leather from being submerged in water during production.

Dimensions: 40 cm x 7 cm x 5 cm (15 3/4" x 2 3/4" x 2")

Please note: Due to UK legislation, anyone wishing to buy this piece must be 18 years or over; see restricted ownership notice in the Buyer's Guide

Estimate. £3,000 - 5,000



150

Mario Kirner Collection:
Jason's (Kane Hodder) Photo-
matched Full Costume 
Friday The 13th Part VIII: Jason Takes Manhattan (1989)

Jason's (Kane Hodder) full costume from Rob Hedden's slasher sequel Friday the 13th Part VIII: Jason Takes Manhattan. This lot comes from the personal collection of Friday the 13th collector and historian Mario Kirner. Throughout the film, Jason wore his costume, which was drenched in wet slime, as he hunted a group of high-school graduates on a cruise ship en route to New York after being accidentally resurrected from the bottom of Crystal Lake. Markings and distressing on the right glove can be matched to a behind-the-scenes photo of Hodder getting dressed. For this costume three hero shirts were made, each featuring a large gash cut out on the front right section. During filming, Kane accidentally tore this production-made hole down through the hem, so it hangs open. For continuity, the production team stitched it back together between shots and remnants of this brown-coloured thread are still present on the shirt. This damage, as well as the bullet hole and a bleached line that runs parallel to the front button-up closure (which is unique to the piece), can be photo-matched to a behind-the-scenes image taken between shots. The shirt also features a snap fastener added below the collar's top button to restrict the shirt from opening too far and revealing the actor's skin beneath the foam rubber cowl. Hodder also wore his costume during an appearance on "The Arsenio Hall Show" and at the 1990 "The Horror Hall of Fame" awards to promote the film's theatrical release. This costume was displayed for 15 years at the Las Vegas Planet Hollywood, where it was a centrepiece for many fans and restaurant guests. The costume consists of a grey shirt (size "XXL") a pair of grey trousers, black steel cap leather boots (size "12") and a pair of black leather gloves. The gloves included are the only pair made for this film and exhibit fake bloodstains, the trousers feature a label with "Kane", and the shirt includes a label that reads "Burn & Hit 3", both handwritten in black pen. All the items have been intentionally distressed, scuffed, torn or dyed for production.

Estimate. £15,000 - 25,000



151

Mario Kirner Collection:
Jason Voorhees' (Kane Hodder)
Screen-matched Hockey Mask
**Friday The 13th Part VIII: Jason
Takes Manhattan (1989)**

Jason Voorhees' (Kane Hodder) screen-matched hockey mask from Rob Hedden's slasher sequel Friday the 13th Part VIII: Jason Takes Manhattan. Throughout the film, Jason wore his infamous hockey mask as he stalked and terrorised a class of high-school graduates on a cruise ship en route to New York after being accidentally resurrected from the bottom of Crystal Lake. The mask can be matched to the one seen on screen for the majority of the film from the placement of the markings and stains across it. Out of five made for the production, this was the main hero mask to be worn by Hodder.

Originating from the personal collection of Mr. Hodder, this mask shares several characteristics, such as its larger and rounder overall shape, with the masks that were produced by the Part VI vacuum form moulds. A groove runs across the mouth holes on the inside, which indicates it may have cracked under the vacuum pressure or was cast from one of the later Part VI masks.

The hockey mask is made from clear acrylic and spray-painted yellow with three painted red triangular emblems on the forehead and cheeks. It features three leather straps held together by a three-sided halter square brass buckle. Intentional distressing has been applied, including the axe crack in the forehead from Part III. Remnants of glue and paint runs are present on the mask's interior, and the leather straps exhibit stains and cracking from being submerged in water during the production.

Dimensions: 28 cm x 26 cm x 11 cm

Estimate. £40,000 - 60,000





152
Mario Kirner Collection: Jason Voorhees' (Kane Hodder) Screen-matched Distressed Shirt Ω
Jason Goes To Hell: The Final Friday (1993)

Jason's (Kane Hodder) screen-matched distressed hero shirt from Adam Marcus' horror sequel Jason Goes to Hell: The Final Friday. Jason wore his shirt as he was resurrected and fought against Jessica (Kari Keegan) and Steven (John D. LeMay). The shirt matches the one worn by Jason on screen, from the moment he and Steven fell through the window of the Voorhees home, to the point where tree demons pulled him beneath the earth.

The grey polyester-and-cotton shirt is size "XXXL Long" and has been intentionally distressed, with rips, tears, holes, stage blood and staining. It is one of two hero shirts worn by Hodder during the production.

Estimate. £4,000 - 6,000

153
Mario Kirner Collection: Screen-matched Demon Dagger Ω
Jason Goes To Hell: The Final Friday (1993)

The screen-matched demon dagger from Adam Marcus' horror sequel Jason Goes to Hell: The Final Friday. Jessica (Kari Keegan) used the demon dagger to stab Jason (Kane Hodder) in the chest, releasing the souls of his victims and causing him to be dragged to hell. The dagger matches the one on-screen through markings and imperfections on its handle during the scene in which Jessica wrestled Sheriff Landis (Billy Bush) and Officer Randy (Kipp Marcus) for the knife.

The handle is made of resin and features a demon head at the pommel, with a faux diamond in the middle of the handle and faux rubies in the eyes, while the blade is made of steel. The dagger is accompanied by a leather sheath. The handle has some wear from use, including some chips, and a couple of the demon's horns have come off. The blade has some tarnishing. Dimensions: 48.5 cm x 13.5 cm x 8 cm (19" x 5 1/4" x 3 1/4")

Estimate. £4,000 - 6,000

154
Mario Kirner Collection: SFX Jason Voorhees Body Ω
Jason Goes To Hell: The Final Friday (1993)

An SFX Jason body from Adam Marcus' horror sequel Jason Goes to Hell: The Final Friday. Jessica (Kari Keegan) used the demon dagger to stab Jason (Kane Hodder) in the chest, releasing the souls of his victims and causing him to be dragged to hell. Three bodies were made for the production, with this one used for the close-up of the dagger being driven into the chest. It can also be seen in a behind-the-scenes shot with the director Adam Marcus.

Originally created by KNB EFX special effects artists Mark Tavares and Brian Rae, the body is made of urethane foam with a metal skeleton, and is displayed on a metal stand. It has been hand-painted and features a hole in the chest from the dagger. The foam urethane has become dry and fragile in places.

Estimate. £3,000 - 5,000

155
Mario Kirner Collection: Jason Voorhees' (Kane Hodder) Screen-matched Costume Ω
Jason X (2001)

Jason's (Kane Hodder) screen-matched costume from Jim Isaac's horror sequel Jason X. Jason wore his costume for much of the film, as he was cryogenically frozen, before tormenting teens in the future.

The costume consists of a torn straitjacket, a grey shirt, and a pair of grey trousers. The tears and markings on the straitjacket screen-match it to the scenes set before Jason is frozen, as well as promotional shots. It is decorated with metal buckles and broken shackles, and has "Before the Freeze" handwritten in the collar, alongside other faded notes. The shirt also has some faded notes in the collar, and both the shirt and trousers have been distressed with bloody bullet wounds.

Estimate. £7,000 - 10,000



156
Mario Kirner Collection: Jason Voorhees'
(Ken Kirzinger) Screen-matched Battle-damaged
Hockey Mask and Cowl 
Freddy Vs. Jason (2003)

Jason's (Ken Kirzinger) screen-matched battle-damaged hockey mask and cowl from Ronny Yu's horror sequel Freddy Vs. Jason. Jason wore his iconic hockey mask throughout the film as he terrorised teenagers and battled Freddy Krueger (Robert Englund). The mask matches the one on-screen at the end of the film as Jason sinks slowly into the water through the scarring and damage inflicted upon it. The resin and fibreglass mask features leather straps with metal buckles, and has foam padding on the inside for the actor's comfort. The right eye hole features a section of Jason's face and his damaged right eye built into the mask. The damaged eye was originally mistakenly attached to the left eye and the mistake was noticed a few days into filming, meaning those shots had to be flipped in post-production. The remnants of the glue around the left eye remains. The hockey mask has also been autographed on the inside by Ken Kirzinger and stunt performer Douglas Tait, who has also inscribed "Give me back my Dam [sic] mask!"

The cowl is made of foam rubber and was intended to act as a dark frame around the hockey mask, allowing the mask to "pop". Handwritten notes inside indicate it was originally a hero version but was changed to a stunt version during production.

The mask has cracked most notably on the right side but the pieces still adhere to the foam lining. The foam rubber cowl has become dry and flaky and remains in a fragile condition. The lot is accompanied by a certificate of authenticity from New Line Cinema. Dimensions (mask): 24.5 cm x 17 cm x 11 cm (9 3/4" x 6 3/4" x 4 1/4")

Estimate. £30,000 - 50,000



157

Mario Kirner Collection: Jason Voorhees' (Ken Kirzinger) Screen-matched Costume and Autographed Padded Undersuit Ω Freddy Vs. Jason (2003)

Jason's (Ken Kirzinger) screen-matched costume and autographed padded undersuit from Ronny Yu's horror crossover Freddy Vs. Jason. Jason wore his costume throughout the film as he terrorised teenagers and battled Freddy Krueger (Robert Englund).

The costume comprises a coat; a jumper; a long-sleeved T-shirt (size "XXL"); a pair of trousers; a pair of leather boots; a belt (labelled "44 Jason ST"); and a pair of gloves. The jacket has "Darkened Pre Burn - NO MAGIX" handwritten in the left armpit. Magix is used to re-colour leather and stain costume pieces, but makes the material highly flammable. As the costume was intended for use near open flames, applying Magix to it was understandably prohibited. The boots were originally intended to be the hero pair, but ultimately boots with a higher heel were used throughout to make Jason taller and more imposing. The costume has been intentionally distressed with tears, holes, dirt and stage blood, and matches the one seen on-screen during the cornfield rave sequence. The costume was later worn during the official release party of the book Crystal Lake Memories.

The padded undersuit was made for the scene at the end of the film in which Jason walks out of Camp Crystal Lake holding Freddy's head. The soaking wet clothes clung to Jason stunt double Douglas Tait, so he wore the padded undersuit to keep his silhouette bulky. The suit consists of a leotard and a pair of padded trousers. The leotard has several snap buttons on the chest and back, where foam muscles were previously attached. The trousers are autographed by Kirzinger. The lot is accompanied by a certificate of authenticity from New Line Cinema.

Estimate. £20,000 - 30,000



158

Mario Kirner Collection: Jason Voorhees' (Ken Kirzinger) Screen-matched Hero Machete Ω Freddy Vs. Jason (2003)

Jason's (Ken Kirzinger) screen-matched hero machete from Ronny Yu's horror crossover Freddy vs. Jason. Jason used his machete throughout the film, while cutting down teenagers and fighting against Freddy Krueger (Robert Englund). At one point, he even had it turned against him by Freddy. Production designer John Willett designed the film's machetes, and many were made for a variety of different uses and "gags".

This machete matches the one on-screen through markings and tarnishing on the blade, most clearly in the fight between Freddy and Jason in Jason's dream but also to several other scenes throughout the film. The machete's blade is made of aluminium and its resin handle is wrapped in white tape. The weapon has been intentionally distressed to appear well used and the blade retains some spots of stage blood. Dimensions: 76 cm x 2.5 cm x 11.5 cm (30" x 1" x 4 1/2")

Estimate. £15,000 - 25,000



159
Freddy Krueger's (Robert Englund)
Glove M
Freddy Vs. Jason (2003)

Freddy Krueger's (Robert Englund) glove from Ronny Yu's horror crossover *Freddy Vs. Jason*. Freddy wore his iconic glove throughout the film as he terrorised Lori (Monica Keena) and her friends, and then faced off against Jason Voorhees (Ken Kirzinger). The glove was originally designed and created by Jim Doyle, the mechanical special effects designer of Wes Craven's *A Nightmare on Elm Street*. When he asked Craven for guidance on the design, the director said, "It's kind of like real long fingernails. I want the glove to look like something that someone could make who has the skills of a boilermaker, because this guy worked in a boiler room."

This glove is made of tan-coloured leather with soot and light stage-blood markings. The tips and palm of the glove have been cut off, and a blade assembly has been fitted, comprising tarnished copper finger caps with a single pivot point, riveted to a backplate that is fixed to the glove's rear. Made for use in the film's fight scenes, the claws are made of resin, painted to resemble steel and secured to the tips of the fingers with glue and wire, which provides a strong hold, but allows for simple replacement in the event of breakages.

The glove shows production-applied distress, including scratches on the metal fingers and backplate, to give it a battle-worn appearance. Small dots have been drilled into the glove to create the illusion of weld splatter from its creation during the opening montage. However, it shows some unintentional wear, including repairs to the ring-finger claw, a replaced rivet in the little finger's claw mount and fraying to the stitching throughout. The glove comes on a custom-built display stand and is accompanied by a certificate of authenticity from New Line Cinema. Dimensions (displayed): 27 cm x 17 cm x 32.5 cm (10 1/2" x 6 3/4" x 12 3/4")

Estimate. £25,000 - 35,000



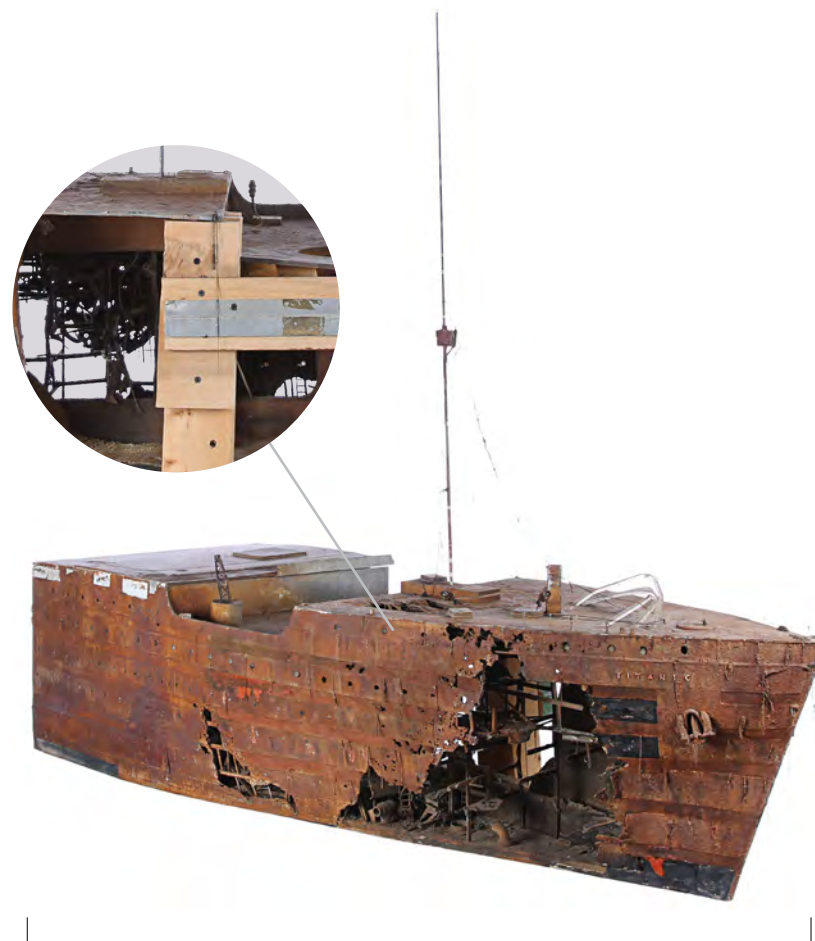
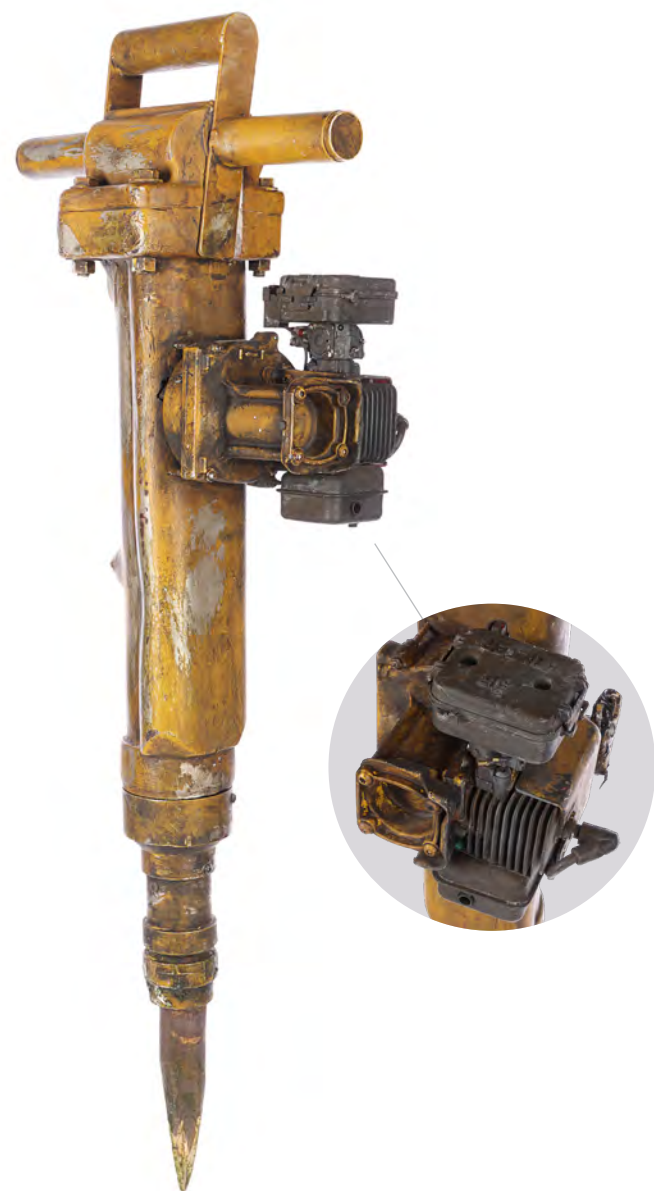

160
 Seth Gecko's (George Clooney)
 Hero Vampire-Stake Jackhammer M
From Dusk Till Dawn (1996)

Seth Gecko's (George Clooney) hero stake jackhammer from Robert Rodriguez's crime-horror film From Dusk Till Dawn. Gecko fashioned a wooden stake with his knife and inserted it into the head of a jackhammer he found while trapped in a storeroom with the other surviving patrons of the Titty Twister strip club. He then used the jackhammer to kill numerous vampires.

The jackhammer is made of fibreglass and cast resin with various metal components. It has a faux wooden stake made of foam, an engine and an air filter. Thick green paint has been applied around its head to simulate coagulated vampire blood. Expertly painted in gold and intentionally distressed, the heavy weight of the jackhammer adds to its realism. Dimensions: 108 cm x 42 cm x 23 cm (42 1/2" x 16 1/2" x 9")

Contains electronics; see electronics notice in the Buyer's Guide.

Estimate. £8,000 - 12,000

161
 Screen-matched Titanic Model Miniature +
Ghostbusters II (1989)

A screen-matched model miniature of the R.M.S. Titanic from Ivan Reitman's supernatural comedy sequel Ghostbusters II. The Titanic and its ghostly passengers appeared at the New York docks after the evil slime under the streets of the city began to cause widespread chaos. The model matches the one seen on screen, identified by the holes and markings toward the front.

Built for the production by the artists at Industrial Light & Magic, the miniature is of the bow section of the ship and is predominantly resin sheet mounted over a wooden frame, with carved biscuit foam inside for shape and stability. The ship is intentionally distressed to look like it has been at the bottom of the Atlantic for decades, with a large gaping hole on the right side.

There are a couple of small lights and some clear perspex rods on the deck through which light would have emanated, giving a ghostly glow, although these are no longer functional.

The ship has some wear from age and use, and several of the resin panels and railings are no longer present on the sides of the ship. Dimensions: 155 cm x 53 cm x 140 cm (61" x 20 3/4" x 55")

Special shipping required; see special shipping notice in the Buyer's Guide.

Contains electronics; see electronics notice in the Buyer's Guide.

Estimate. £8,000 - 12,000



162
 Peter Venkman's (Bill Murray) Coat M
Ghostbusters II (1989)

Peter Venkman's (Bill Murray) coat from Ivan Reitman's comedy sequel Ghostbusters II. Venkman wore his green Henry Cotton's coat in several scenes throughout the film, and Dana Barrett (Sigourney Weaver) also wore it when she tried to save her son from Janosz (Peter MacNicol).

The jacket has a wool lining and four buttons down its front. There is some minor staining on the front and on the left cuff.

Estimate. £4,000 - 6,000



163
 Set of Slimer and Scleri Brothers Maquettes Ω
Ghostbusters II (1989)

Slimer and Scleri Brothers maquettes from Ivan Reitman's action-comedy sequel Ghostbusters II. Slimer vexed Tully (Rick Moranis) throughout the film, while the ghoulish Scleri Brothers ran amok during court proceedings against the Ghostbusters.

These maquettes were created by Industrial Light & Magic (ILM) as design references for the character puppets. The Slimer maquette is made from brown resin mounted to a black base, while the white plaster Brothers maquettes are painted grey. ILM sculptor Mark Siegel and the date "10/88" are engraved on one Scleri's back. Each maquette exhibits scratching and paint chipping. Dimensions (largest): 19.25 cm x 19.25 cm x 15.25 cm (7.5" x 7.5" x 6"); (smallest): 16.75 cm x 10.25 cm x 11.43 cm (6.5" x 4" x 4.5")

Estimate. £5,000 - 7,000

164
Commodus' (Joaquin Phoenix)
Rome Chariot M
Gladiator (2000)

Commodus' (Joaquin Phoenix) chariot from Ridley Scott's historical epic *Gladiator*. Commodus triumphantly rode his chariot alongside his sister Lucilla (Connie Nielsen) as he returned to Rome after the death of his father Marcus Aurelius (Richard Harris) and the defeat of the Germanic tribes.

The chariot is made primarily of wood, with a metal frame. The wood is covered in black leather and features resin decorations and a gold-painted fibreglass eagle mounted front and centre on the leather. The wheels feature metal rims and spokes. The chariot has some wear from production use and age, most notably missing or damaged decorations from the front. Dimensions: 140 cm x 186 cm x 183 cm (55" x 73 1/4" x 72")

Special shipping required; see special shipping notice in the Buyer's Guide.

Estimate. £40,000 - 60,000



Everett Collection Inc / Alamy Stock Photo



1.8 m (6.1')

165
 Maximus' (Russell Crowe)
 General Helmet M
Gladiator (2000)

Maximus' (Russell Crowe) general helmet from Ridley Scott's Oscar®-winning historical epic *Gladiator*. Maximus wore his helmet while leading the Roman legions against the barbarian tribes of Germania during the opening battle.

The helmet is made of fibreglass with embedded metal powder, giving the impression it is constructed from gold-coloured metal, and is lined with padded light brown leather. A grey-painted wolf's head emblem with surrounding filigree-style patterns decorates the front, and the sides of the helmet display moveable cheek guards, which tie together via a piece of attached brown leather cord. A fin featuring a brown synthetic-hair plume runs along the top towards a neck guard incorporated into the helmet's rear. The helmet comes presented on a custom-made display. Some of the interior leather has begun to peel away in places. Dimensions (displayed): 36 cm x 20 cm x 53 cm (14 1/4" x 8" x 20 3/4")

Estimate. £8,000 - 12,000



166
 Maximus' Screen-matched
 'Proximo' Cuirass M
Gladiator (2000)

Maximus Decimus Meridius' (Russell Crowe) cuirass from Ridley Scott's historical epic *Gladiator*. Antonius Proximo (Oliver Reed) gave his cuirass to Maximus after Maximus agreed to "win the crowd" at the Colosseum. This cuirass screen-matches the scene where Proximo picked up the cuirass and threw it to Maximus, who caught and inspected it.

The cuirass comprises a breastplate and a backplate and two leather straps that sit laterally under each arm. Made of formed dark brown leather, the cuirass features moulded abdominal and pectoral muscles and faux-silver breastplate embellishments showing two sejant griffins and a laurel wreath. The breastplate connects to the backplate at the shoulders via leather cords that are tied into punched holes, and above the hips via dual leather buckles. The underarm leather straps connect to the breastplate and backplate via leather cord tied to hidden metal brackets.

The film's costume designer Janty Yates stated that 12 sets of armour were created for Maximus, and that it was Crowe's idea to add silver embellishments to the cuirass breastplate. As Maximus won more gladiatorial contests later in the film, further icons appeared on his breastplate. The cuirass has been intentionally weathered and remains in very good condition.

Estimate. £10,000 - 15,000





167
 Maximus' (Russell Crowe) Slave Costume Display M
Gladiator (2000)

Maximus' (Russell Crowe) slave costume display from Ridley Scott's historical epic *Gladiator*. Maximus wore his costume when he was first taken into slavery by Proximo (Oliver Reed).

The costume consists of a long sackcloth tunic labelled "RC" inside the collar, and a large brown leather belt with metal buckles. The belt is labelled "Peter Olgay" and "Prox Guard 1" in black marker and is added to complete the costume. The costume has been intentionally distressed with staining and frayed edges. It is displayed on a custom-made display, featuring the film's title on the base. Dimensions (display): 38 cm x 53 cm x 186 cm

Contains electronics; see electronics notice in the Buyer's Guide.

Special shipping required; see special shipping notice in the Buyer's Guide.

Estimate. £6,000 - 8,000



168
 Maximus' (Russell Crowe) Tooth Necklace M
Gladiator (2000)

Maximus' (Russell Crowe) tooth necklace from Ridley Scott's historical epic *Gladiator*. Maximus wore his necklace throughout the film. The necklace is made of cotton twine with two resin pendants shaped and painted to look like lupine teeth. There is a small resin button at the back for fastening, and the necklace has been intentionally distressed to look well worn.

Estimate. £4,000 - 6,000



169
 Henry Hill's (Ray Liotta) Watch Ω
Goodfellas (1990)

Henry Hill's (Ray Liotta) watch from Martin Scorsese's crime drama *Goodfellas*. Hill wore his watch throughout the film, including when he beat up his wife Karen's (Lorraine Bracco) neighbour and when Tommy DeVito (Joe Pesci) inquired how, exactly, he was "funny."

This Orion quartz watch is one of only three worn during production. It features a black lizard leather band with a gold-plated face, buckle, and dial. Also included is a Letter of Authenticity from prop master Robert J. Griffon, Jr. The watch's battery is dead, and its current functionality is unknown.

Contains mechanical components; see notice in the Buyer's Guide.

Estimate. £3,500 - 5,500



170
 Daffy Gremlin Paint Test Head Ω
Gremlins 2: The New Batch (1990)

A gremlin Daffy paint test head from Joe Dante's horror comedy sequel *Gremlins 2: The New Batch*. After Daffy transformed into a gremlin, he terrorised the employees at Clamp Centre to comedic effect.

Created by Rick Baker and his team, this lot consists of a final paint test for the gremlin version of Daffy. Constructed of foam and painted green and black in a reptilian pattern, this lot features Daffy's recognizable askew eyes, and small foam spikes on the top of the head. It also features a goofy smile and smaller spikes around the eyes and cheeks. This test head comes with a wooden base. The lot exhibits mild paint cracking from age. Dimensions: 58.5 cm x 28 cm x 25.5 cm (23" x 11" x 10")

Estimate. £8,000 - 12,000



171
Lunging Gremlin
Mohawk Puppet Ω
Gremlins 2: The New Batch (1990)

A lunging gremlin Mohawk puppet from Joe Dante's horror comedy Gremlins 2: The New Batch. After he transformed into a gremlin, Mohawk burst out of the studio's control panel and wreaked havoc on employees at Clamp Centre.

This lot consists of a waist-up, foam-filled latex gremlin puppet with outstretched arms designed to "burst" out of a console. It features Mohawk's reptilian-like painted spikes and eyes, latex fin appendages, and resin claws along with his namesake spiny mohawk. A new black base is included to provide internal support for Mohawk and his arms. This puppet has been painstakingly restored by Brian Penikas, a painter for the original production of Gremlins, and his team at Make-Up and Monsters Studios. This lot exhibits fragility in the foam and latex with cracks in the paint and missing pieces in the spines and spikes from age. Dimensions: 82.75 cm x 53.5 cm x 96.75 cm (32.5" x 21" x 38")

Estimate. £20,000 - 30,000



172
Michael Myers' (Chris Durand)
 Mask M
Halloween H2O: 20 Years Later
(1998)

Michael Myers' (Chris Durand) mask from Steve Miner's slasher sequel Halloween H2O: 20 Years Later. The iconic serial killer wore his mask throughout the film as he travelled to California to attempt to finally slay his sister Laurie Strode (Jamie Lee Curtis), now under the new identity of Keri Tate, 20 years after their initial encounter.

Four different designs were created for the production: the KNB mask, the Stan Winston mask, the Buechler mask, and an unusual looking CGI mask that was superimposed in one scene. Several weeks into shooting, Miner was instructed by producers to change the appearance of Myers' mask. This example is one of two created by Stan Winston Studios for re-shoots, replacing the original KNB mask. It is seen in several scenes, mainly in close-up shots of Michael, including the film's finale when Laurie decapitates her murderous brother. All four designs feature wider eyeholes than the masks in previous films.

The latex mask - based on the William Shatner mask famously used in John Carpenter's 1978 original - is painted off-white, with brown-painted eyebrows and faux brown hair. There is an intentional split up the back with strips of Velcro adhered, allowing it to be easily worn, and this particular example has an extended neck section. There are some minor holes in the latex and some discolouration around the neck. The lot is accompanied by a Miramax certificate of authenticity. Dimensions: 23 cm x 19 cm x 42 cm (9" x 7 1/2" x 16 1/2")

Estimate. £20,000 - 30,000



173
Michael Myers' (Brad Loree)
 Burnt Axe Attack Mask M
Halloween: Resurrection (2002)

Michael Myers' (Brad Loree) burnt axe-attack mask from Rick Rosenthal's slasher sequel Halloween: Resurrection. Towards the end of the film, Myers was left to die in a fire in a garage after being electrocuted by Freddie Harris (Busta Rhymes). His burnt mask is seen in the final shot, when his eyes suddenly open as a coroner prepares to examine his body.

This mask was created for an alternate ending scene where Sara (Bianca Kajlich) and Freddie spoke to Michael while he was lying in a body bag, presumed dead. Michael suddenly grabbed Freddie's throat, and Sara slammed a fire-truck axe into his head. Three alternate endings were filmed for the production and can be seen in the special features on the DVD.

The design of the mask for Halloween: Resurrection was almost identical to the one used in John Carpenter's 1978 original, which was famously based on a William Shatner mask. This mask is made of rubber, painted off-white and heavily distressed to appear burnt and melted in places. It is intentionally split down the centre, representing the axe wound, and comes presented on a biscuit foam bust with strips of silver-coloured tape adhered around the edges and underside. There are remnants of stage blood present on the mask and bust. Dimensions (displayed): 27 cm x 33 cm x 44 cm (10 1/2" x 13" x 17 1/4")

Estimate. £8,000 - 12,000



174
Michael Myers' (Tyler Mane)
 Screen-matched Bloody Overalls M
Halloween (2007)

Michael Myers' (Tyler Mane) screen-matched bloody overalls from Rob Zombie's horror remake Halloween. Myers wore his costume for much of the film as he terrorised Laurie Strode (Scout Taylor-Compton) and her friends. Markings on the overalls and holes on their back screen-match them to the scene where Myers followed Laurie home from school.

The brown canvas overalls are intentionally distressed, with dirt, stains, stage blood and holes. They have "54T" handwritten on both the collar label and inside the right armpit.

Estimate. £8,000 - 12,000



175
First Edition Hardback Book 
Harry Potter And The Philosopher's Stone (2001)

A first edition hardback copy of J.K. Rowling's novel Harry Potter and the Philosopher's Stone. The Philosopher's Stone was the first in Rowling's Harry Potter series, which followed the adventures of a young wizard at Hogwarts School of Witchcraft and Wizardry. It became one of the best-selling books of all time, sparking a worldwide phenomenon.

This copy is one of an initial run of just 500 hardback issues - the first ever printed - many of which were issued directly to libraries. Bloomsbury published it in 1997, and "10 9 8 7 6 5 4 3 2 1" features on the publisher's imprint page. There are two errors in the book which are unique to the first edition. Firstly, the rear cover displays a misspelling of "Philosopher's" as "Philospher's". Secondly, on page 53, the text "1 wand" is repeated twice on a list of equipment.

The back cover showcases artwork (by illustrator Thomas Taylor) of an eccentric wizard not mentioned in any of the books, who was based on the illustrator's father. Eventually, the publishers asked for the portrait to be changed to Hogwarts headmaster Professor Dumbledore. The book exhibits signs of wear on the dust jacket and there is a small tear on the publisher's imprint page, while the pages display some signs of discolouration. However, the lot remains in overall excellent condition, considering its age. Dimensions: 20.5 cm x 13.5 cm x 2 cm (8" x 5 1/4" x 3/4")

Estimate. £100,000 - 150,000

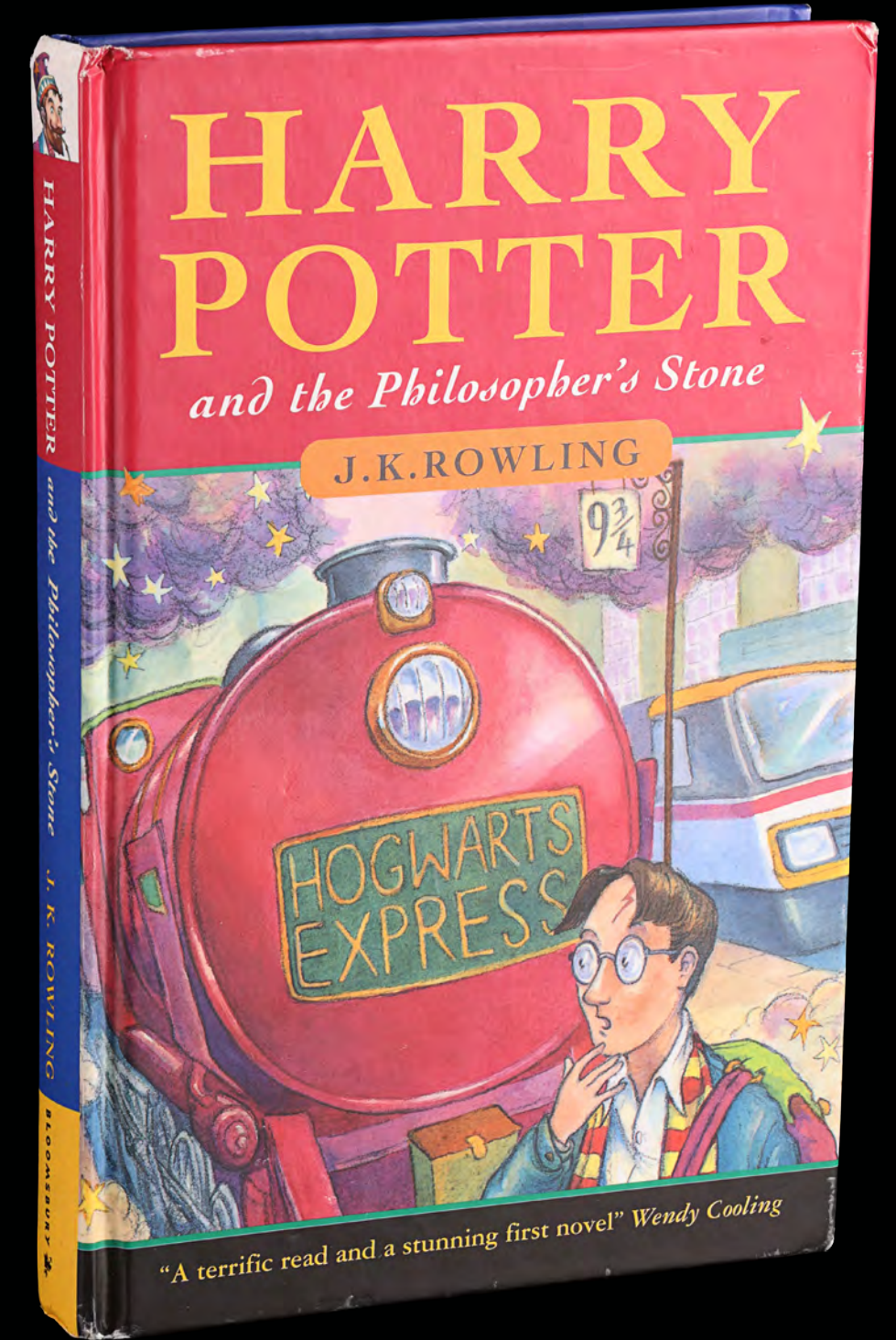
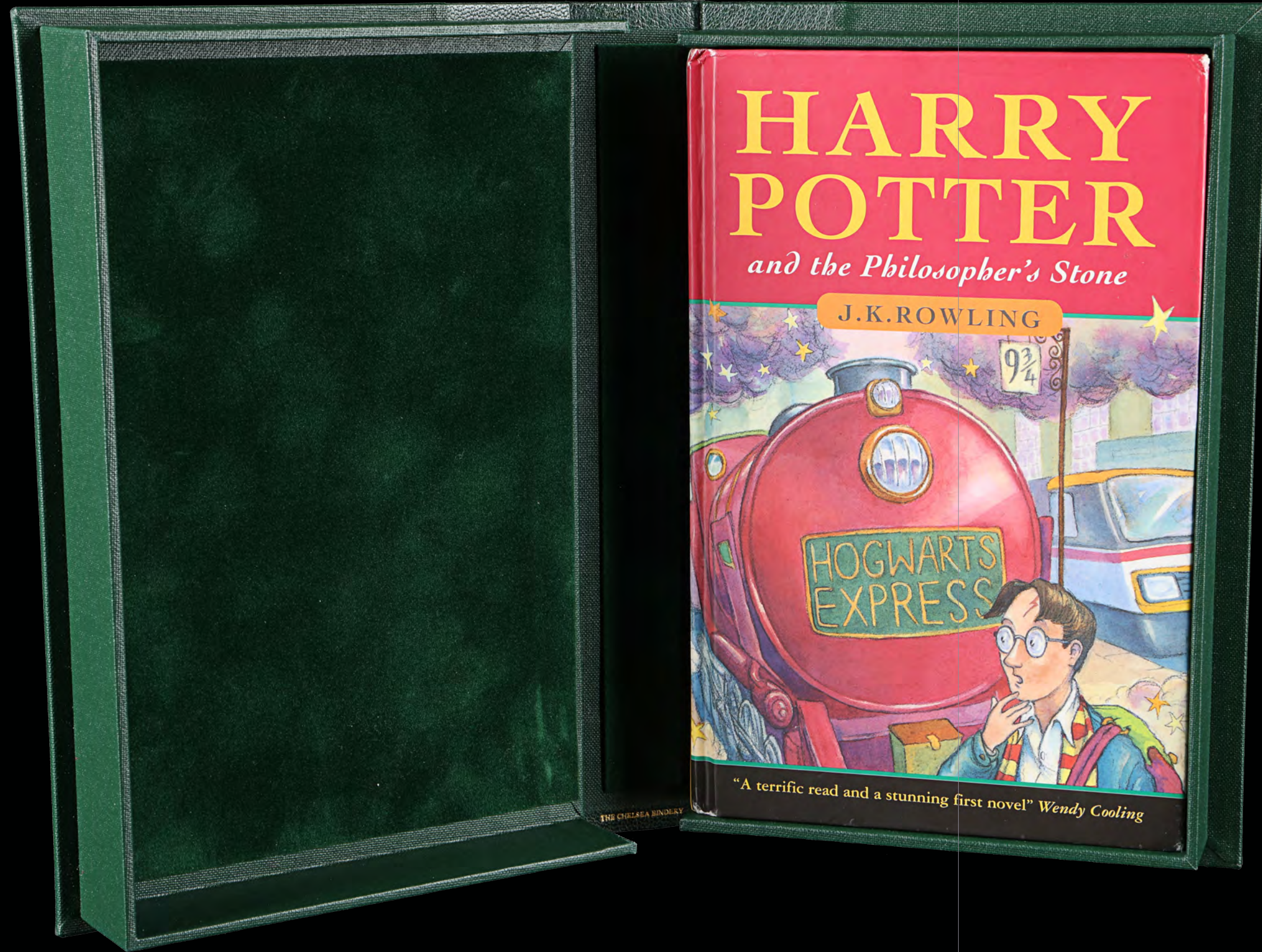
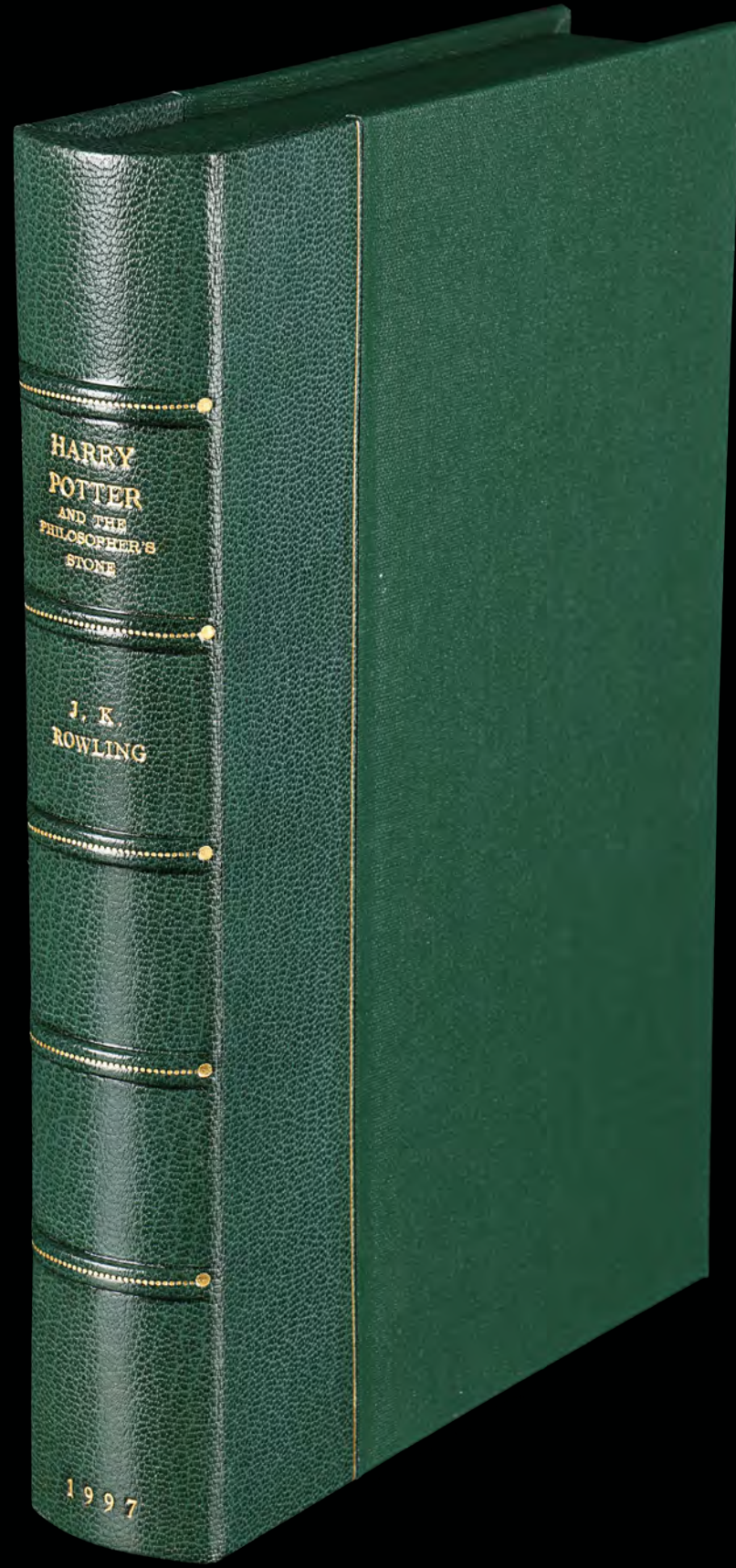

All rights reserved; no part of this publication may be reproduced or transmitted by any means, electronic, mechanical, photocopying or otherwise, without the prior permission of the publisher

First published in Great Britain in 1997
Bloomsbury Publishing Plc, 38 Soho Square, London W1V 5DF

Copyright © Text Joanne Rowling 1997
Copyright © Cover illustration Thomas Taylor 1997

The moral right of the author has been asserted
A CIP catalogue record of this book is available from the
British Library

ISBN 0 7475 3274 5 Paperback
0 7475 3269 9 Hardback

Printed and bound in Great Britain by Clays Ltd, St Ives plc

10 9 8 7 6 5 4 3 2 1

DIAGON ALLEY

53

Fantastic Beasts and Where to Find Them by Newt Scamander
The Dark Forces: A Guide to Self-Protection by Quentin Trimble

Other Equipment

- 1 wand
- 1 cauldron (pewter, standard size 2)
- 1 set glass or crystal phials
- 1 telescope
- 1 set brass scales

→ 1 wand

Students may also bring an owl OR a cat OR a toad

PARENTS ARE REMINDED THAT FIRST YEARS ARE NOT ALLOWED THEIR OWN BROOMSTICKS

'Can we buy all this in London?' Harry wondered aloud.
'If yeh know where to go,' said Hagrid.

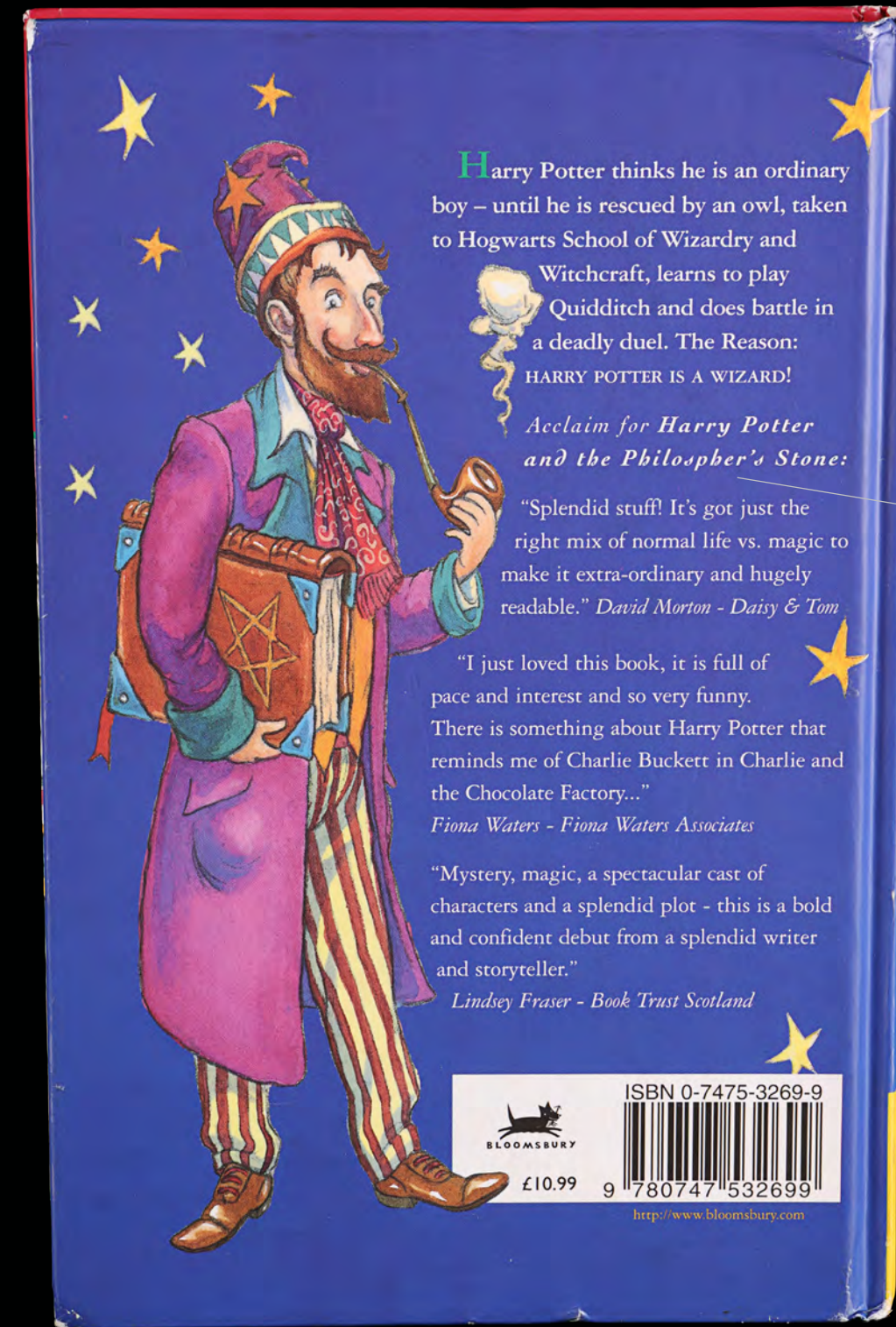

for Harry P
Philosopher's
uff! It's got j

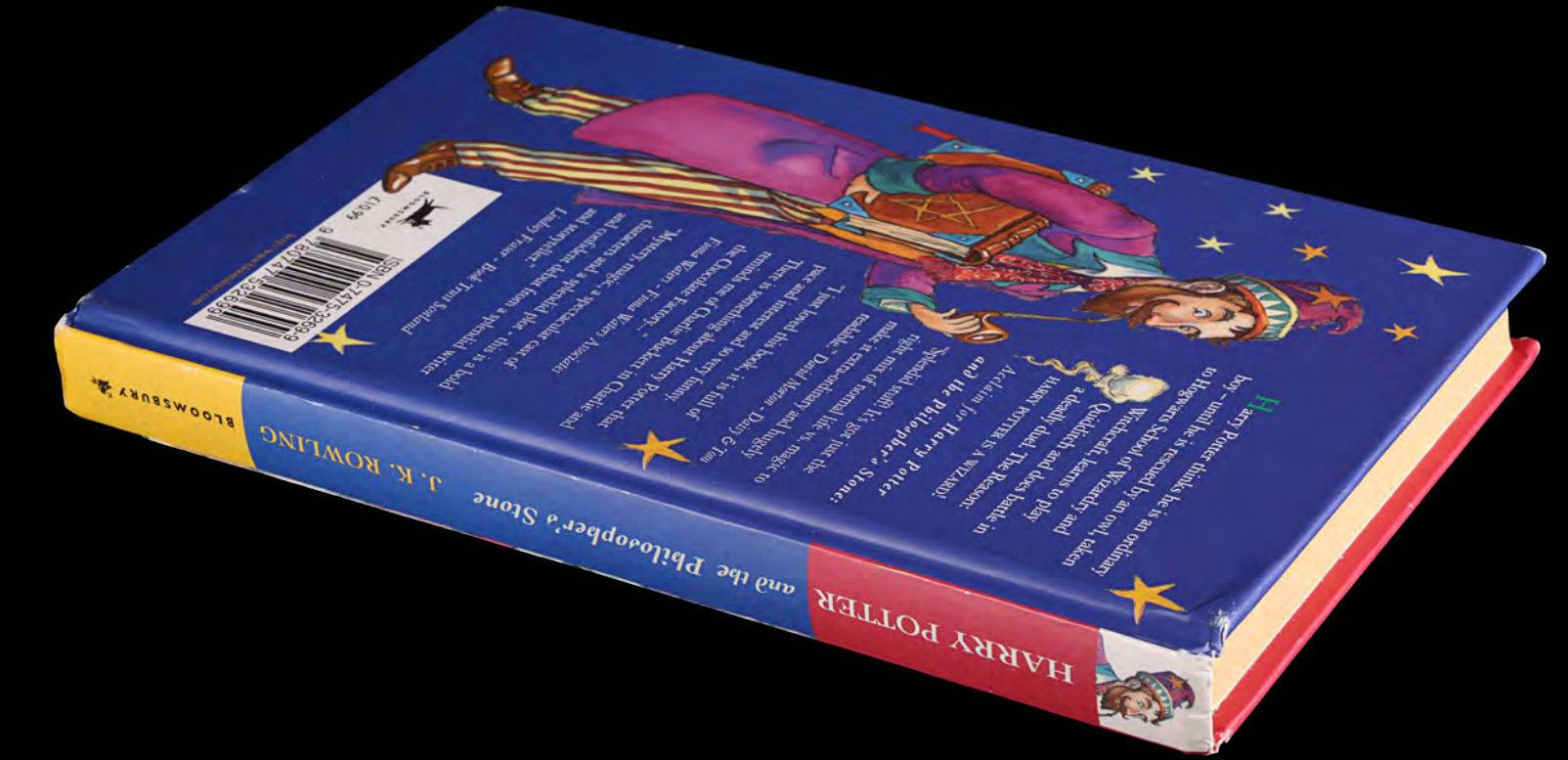
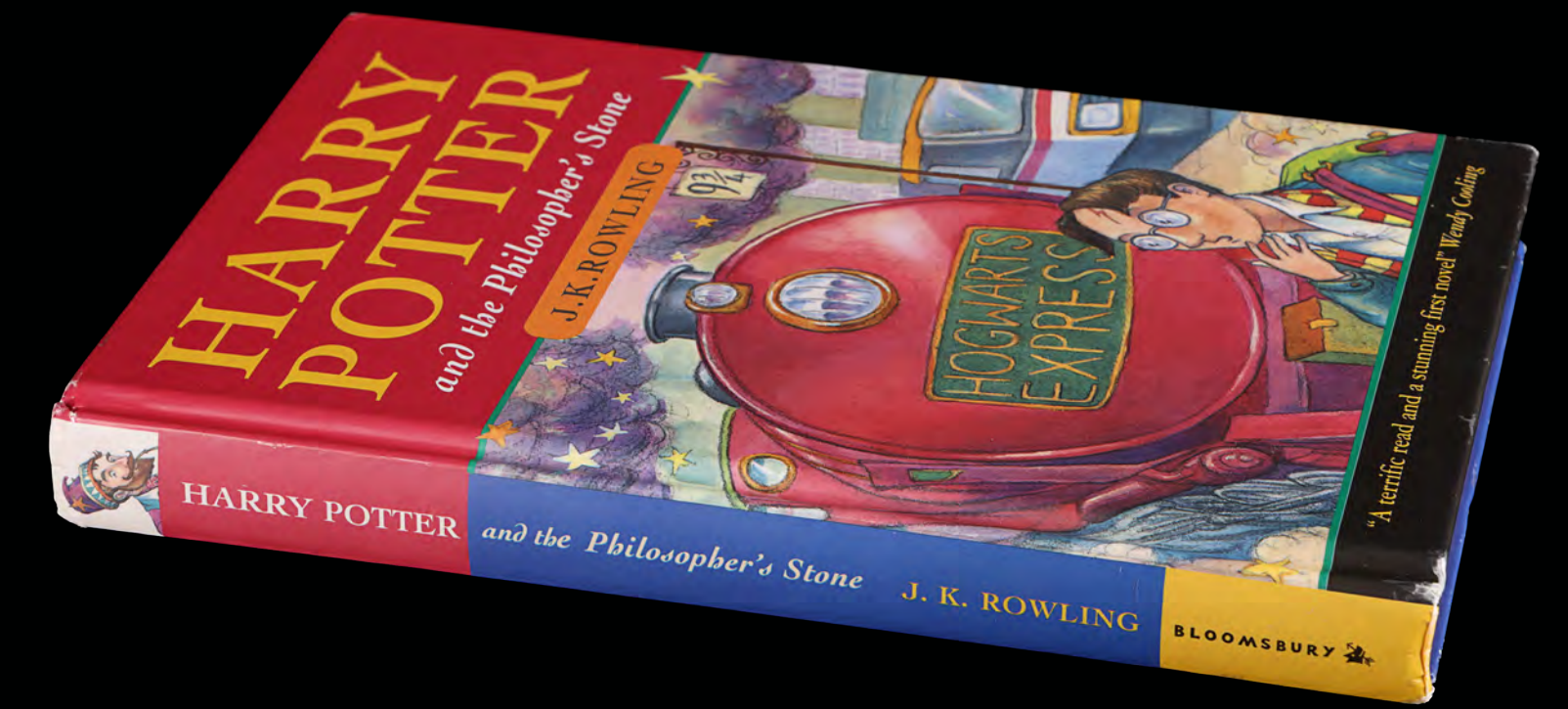

176
 Uncorrected Proof Copy
 of Harry Potter and the
 Philosopher's Stone †Δ
**Harry Potter And The Philosopher's
 Stone (2001)**

An uncorrected proof copy of J.K. Rowling's novel Harry Potter and the Philosopher's Stone. This was the debut novel in Rowling's Harry Potter series, which told the story of a young wizard named Harry and his adventures at Hogwarts School of Witchcraft and Wizardry. It became one of the best-selling books of all time, sparking a worldwide phenomenon. Proof copies are created by publishers and sent to reviewers, book shops and influencers to create a buzz around a book prior to publication.

Approximately 200 copies of this proof first edition book were published. It includes an error on the title page, with Rowling's name misspelt as "J.A. Rowling". The book has only very light handling wear, with a crease down the spine and some very small spots on the back cover. Dimensions: 20 cm x 13.5 cm x 1.5 cm (7 3/4" x 5 1/4" x 1/2")

Estimate. £30,000 - 50,000

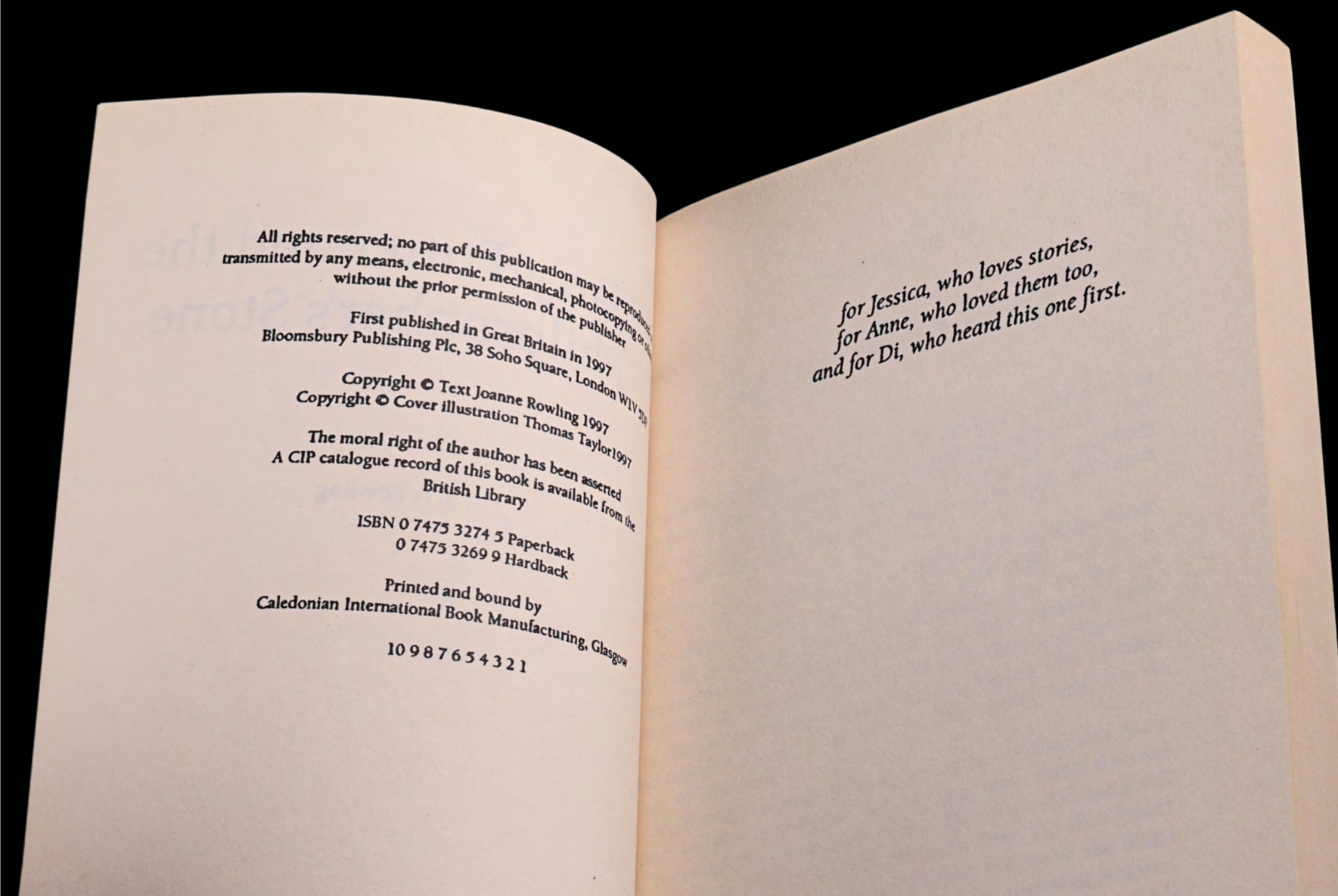
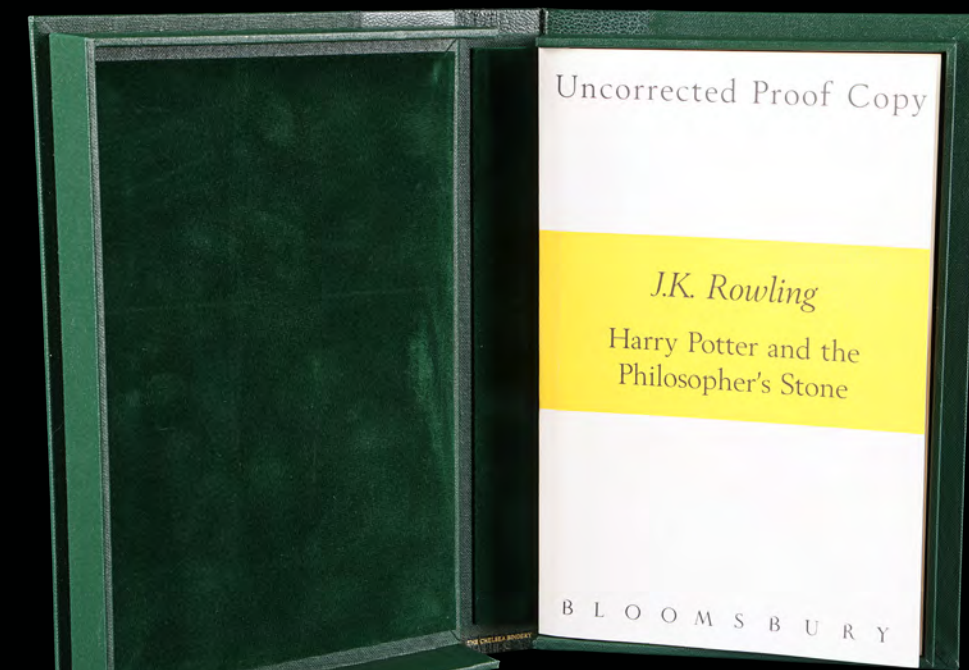
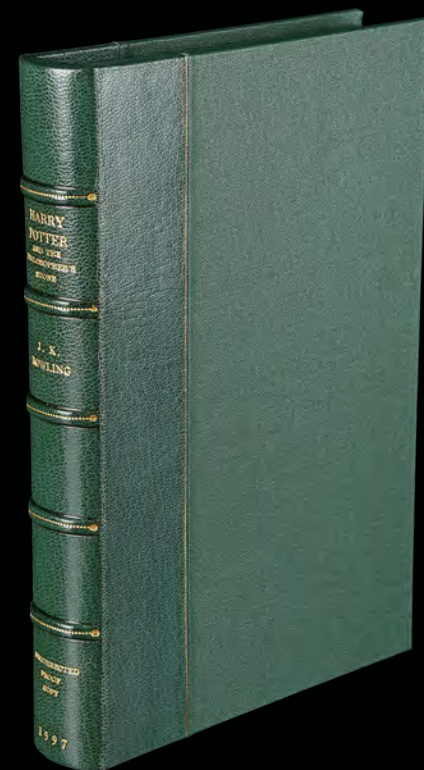
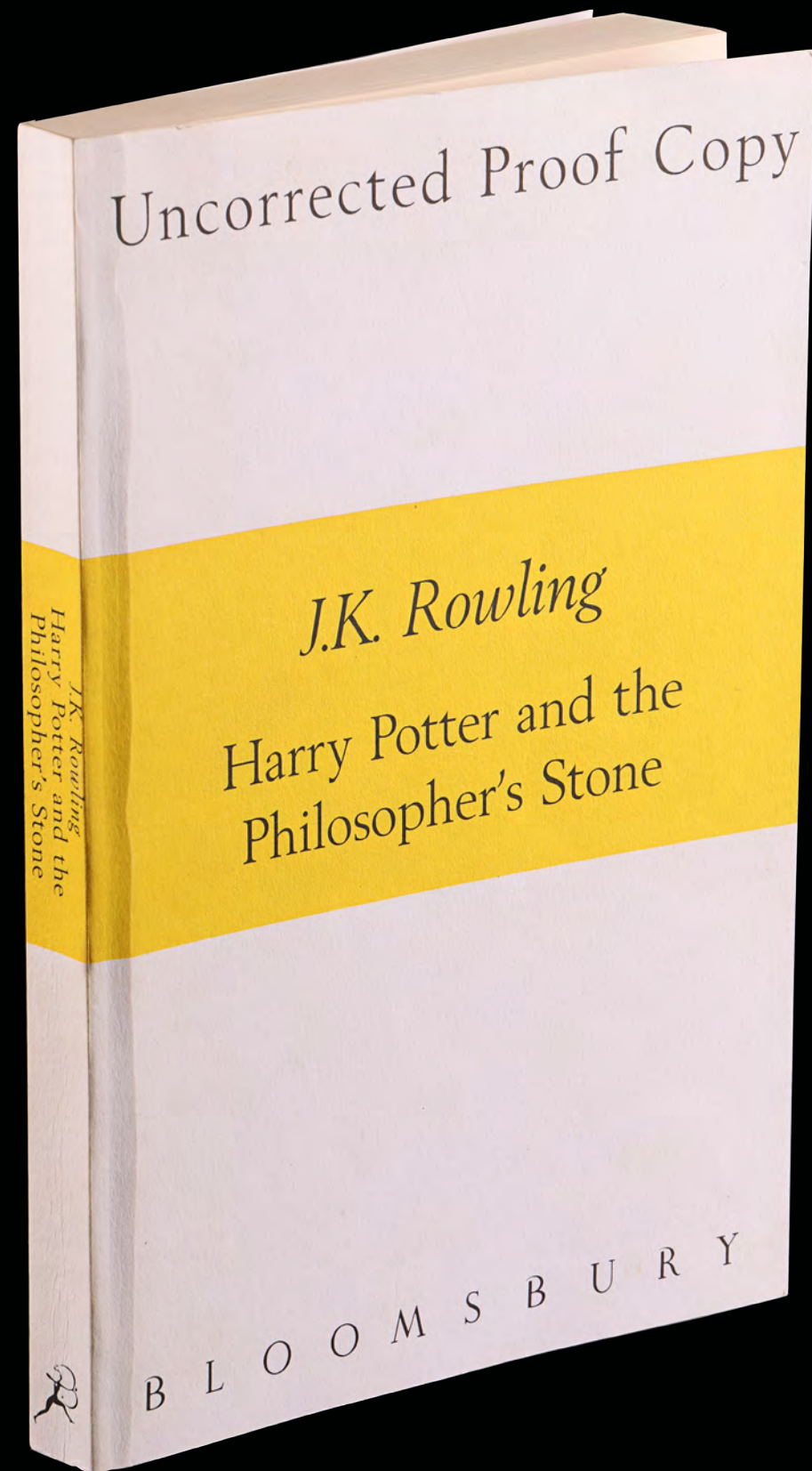
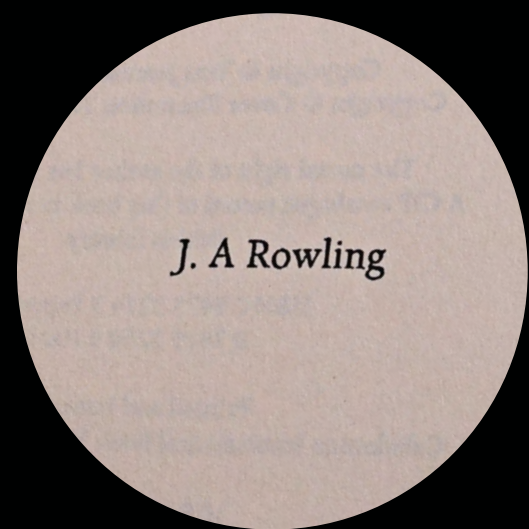

177
No Lot

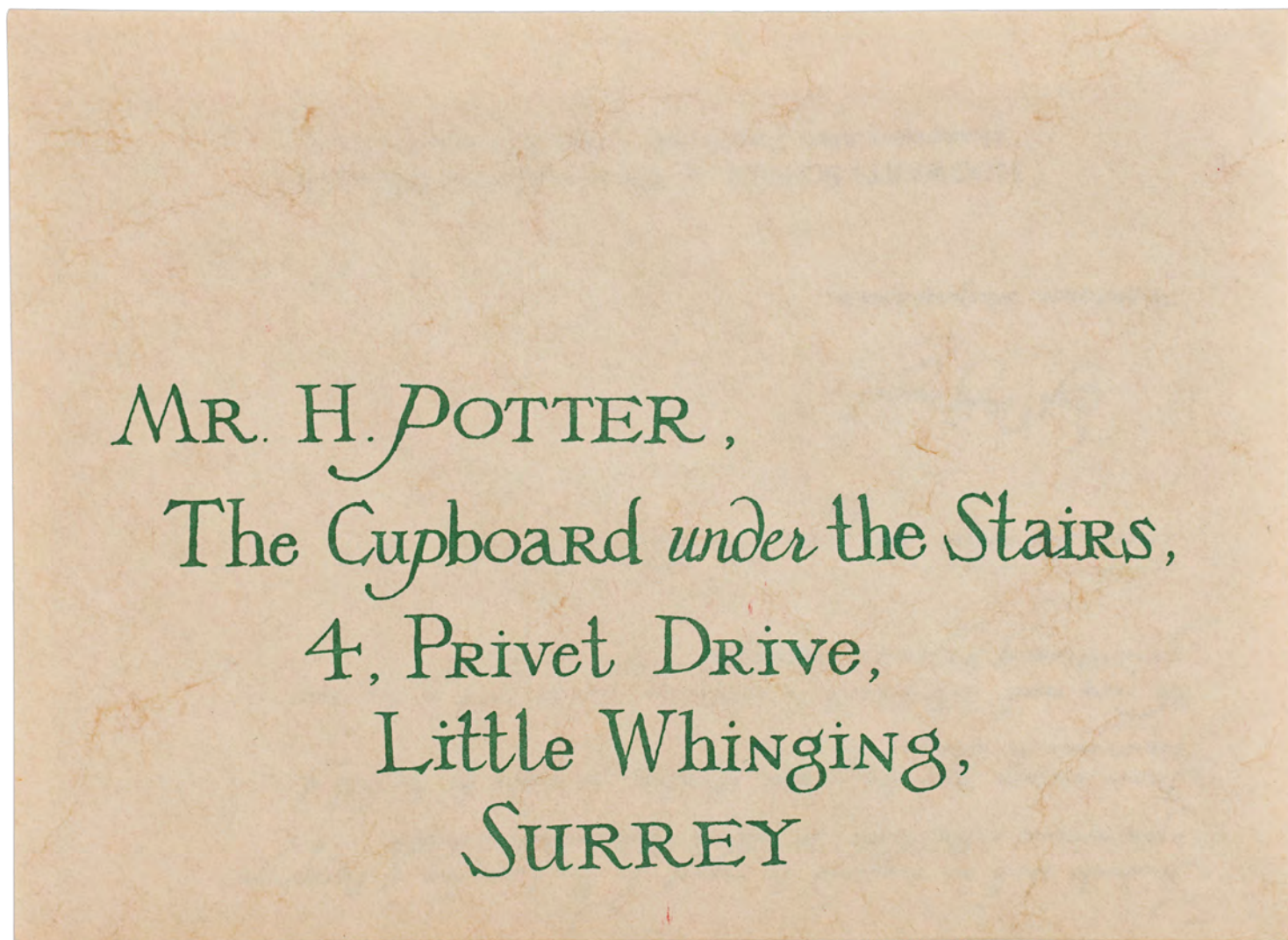

178
 Harry Potter's (Daniel Radcliffe) Hero Hogwarts
 Acceptance Letter M
Harry Potter And The Philosopher's Stone (2001)

Harry Potter's (Daniel Radcliffe) hero Hogwarts acceptance letter from Chris Columbus' fantasy-adventure film Harry Potter and the Philosopher's Stone. Owl post inundated the Dursley household with letters informing Harry Potter (Daniel Radcliffe) of his acceptance into Hogwarts, despite his Uncle Vernon's (Richard Griffiths) best efforts to hide or destroy them.

The envelope is made from marbled-effect paper, with Harry's address printed in green on the front of the envelope and the Hogwarts crest on the reverse. The hero envelope features a real red wax Hogwarts seal, unlike the many entirely printed versions that were also used in the scene, and there is a letter contained within. There is a crack and a small chip present on the wax seal.

The envelope is accompanied by a printed letter of donation from Warner Bros., a copy of the letter contained within, a photocopied front cover of a 2001 edition of USA Weekend featuring Radcliffe opening a similar letter and four tickets from the cast and crew screening of the film. Dimensions (envelope): 13 cm x 18 cm x 0.5 cm (5 1/4" x 7 1/4" x 1/4"); (ticket): 21 cm x 10.5 cm (8 1/4" x 4 1/4")

Estimate. £10,000 - 15,000



179
 Sir Cadogan's (Paul Whitehouse) Complete Suit
 of Armour +
Harry Potter And The Prisoner Of Azkaban (2004)

Sir Cadogan's (Paul Whitehouse) complete suit of armour from Alfonso Cuarón's fantasy sequel Harry Potter and the Prisoner of Azkaban. Sir Cadogan was seen in the background dashing from painting to painting when the Fat Lady's portrait was discovered with a slash through it. The Gryffindor students also encountered Sir Cadogan in a deleted scene.

Created by esteemed armorer Terry English, the aluminium suit comprises a pointed visor; a pot-bellied chest piece; a back piece; pauldrons; arms; gauntlets; thigh guards; leg guards and a set of unverified knitted chain mail. It appears that several components were replaced with plastic elements for shooting, but the costume was returned to its original state after production.

English's signature "T" stamp is present on several pieces, and "Paul Whitehouse, Sir Cadogan, Harry Potter III, Terry English, 2003" is inscribed in red ink on the interior of the helmet and chest piece.

Estimate. £3,000 - 5,000



180
 Daniel Radcliffe, Emma Watson, Rupert Grint, Robert
 Pattinson and Other Key Cast Autographed Poster M
Harry Potter And The Prisoner Of Azkaban (2004)

An autographed poster from the promotion of Alfonso Cuarón's fantasy adventure Harry Potter and the Prisoner of Azkaban. The poster is autographed by 17 cast members from the Harry Potter franchise, including Daniel Radcliffe, Emma Watson, Rupert Grint, Robert Pattinson and Tom Felton. All of the autographs are written in gold-coloured marker pen and many feature their character's name. This poster was signed for a crew member during breaks in filming. It has some creasing, wear on the edges including a tear to the bottom left corner, and a pin hole in each corner. Dimensions: 101.5 cm x 68.5 cm (40" x 27")

Estimate. £1,500 - 2,500



181
Gryffindor Robe [†]Δ
Harry Potter And The Goblet Of Fire (2005)

A Gryffindor robe from Mike Newell's fantasy-adventure sequel Harry Potter and the Goblet of Fire. At various points during the film, students of Hogwarts wore their robes as part of their school uniform.

This black hooded robe, sized "S", features the embroidered Gryffindor House badge on its left chest and two button-loop fastenings at the front. Two handwritten labels attached to the lining read "37G" and "Length 36". The robe exhibits faint stains from production use.

Additional Provenance: The robe was gifted to seven-year-old Alba Diaferia, who, as part of a visit arranged by the Make A Wish Foundation, spent a day with the cast members on the Warner Bros film set at Leavesden Studios. Accompanying this lot is a printed copy of a handwritten letter addressed to Alba from the Harry Potter production team, along with a copy of the photograph taken on the day, showing Alba with the Triwizard champions and Rita Skeeter. This robe was then sold at a Reeman Dansie charity auction, where a percentage of the sale was donated to the Make A Wish Foundation.

Estimate. £8,000 - 12,000



182
Sheriff Chris Mannix's (Walton Goggins) Costume [†]M
Hateful Eight, The (2015)

Sheriff Chris Mannix's (Walton Goggins) costume from Quentin Tarantino's Western The Hateful Eight. Mannix wore his costume throughout the film.

The costume comprises a long black waxed coat; a black jacket; a black woollen waistcoat; a white striped shirt with a grandad collar; and a pair of grey pinstripe trousers. The costume has been intentionally distressed to appear well worn, and is accompanied by a production label, with "Clean #4" handwritten in ink and a list of the scenes.

Estimate. £4,000 - 6,000



183
Oswaldo Mowbray's (Tim Roth) Screen-matched
Costume [†]M
Hateful Eight, The (2015)

Oswaldo Mowbray's (Tim Roth) screen-matched costume from Quentin Tarantino's Western The Hateful Eight. British hangman Mowbray wore his costume throughout the film.

The costume comprises a grey woollen coat; a grey checked jacket; a white shirt; and a pair of grey pinstripe trousers with silvery-grey suspenders. The coat screen-matches one seen on screen in multiple scenes through the distinct pattern of its faux-fur lapel. The costume has been intentionally distressed to appear well worn, with staining around the shirt. The costume is accompanied by a production label, with "Clean #7" handwritten in ink and a list of the scenes it was intended for.

Estimate. £4,000 - 6,000



184
Joe Gage's (Michael Madsen) Coat M
Hateful Eight, The (2015)

Joe Gage's (Michael Madsen) coat from Quentin Tarantino's Western The Hateful Eight. Gage's coat hung over the back of his chair in Minnie's Haberdashery for the majority of the film.

The coat is made from canvas, with a wool lining and a faux fur collar. It is accompanied by a pair of black leather gloves (size "S/M") and a production tag, which indicates which scenes the coat was intended for, and has "Coats (2 of 3)" handwritten at the bottom.

Estimate. £3,000 - 5,000



185
General Sanford Smithers' (Bruce Dern) Coat M
Hateful Eight, The (2015)

General Sanford Smithers' (Bruce Dern) coat from Quentin Tarantino's Western The Hateful Eight. Confederate general Smithers' coat hung on a peg next to his seat for much of the film, and Sheriff Chris Mannix (Walton Goggins) wore it after Sanford's death.

The grey, military-style woollen coat features a cape, and brass buttons with "CSA" (Confederate States of America) in raised lettering. The coat has been intentionally distressed, with two large holes in the front where Mannix was shot while wearing it, and staining from stage blood.

Estimate. £1,000 - 1,500

186
Kroenen's (Ladislav Beran) Full Nazi Costume and Mask M
Hellboy (2004)

Kroenen's (Ladislav Beran) Nazi costume from Guillermo del Toro's fantasy action film Hellboy. Kroenen wore his costume during the opening scenes, in which Rasputin (Karel Roden) and his followers sought to summon a demonic being from another dimension.

The costume consists of a peaked cap, a face mask, a leather jacket, a pair of leather trousers, a pair of leather boots (size 10 1/2) and a metal iron cross hanging from a red, white and black ribbon. The face mask is made of foam rubber and painted black, with a copper-toned mouth grill. It features acrylic eyeholes, rubber straps and a leather neckpiece.

The hat displays the infamous "death's head" badge on its front, while the leather jacket features an SS insignia and a rank patch on the collar, a Nazi party membership badge, a swastika pin on the top left pocket and a red swastika armband sewn onto the left arm. The pieces exhibit some areas of scuffing from production use.

Estimate. £15,000 - 25,000



187
Kroenen's (Ladislav Beran) Black Belt and Sheaths M
Hellboy (2004)

Kroenen's (Ladislav Beran) black belt and sheaths from Guillermo del Toro's superhero film Hellboy. Kroenen wore his belt and sheaths at various points in the film, notably when he killed Abe in the sewers and Professor Brutenholm after reanimating himself at BPRD HQ.

This black leather belt has two dangle sheaths with harnesses that can be fastened around the thighs. An intricately carved design is featured on both the belt and sheaths, along with slight fading and ageing of the leather from production use.

Dimensions: (each sheath) 38 cm x 6 cm x 0.5 cm (15" x 2 1/4" x 1/4")

Estimate. £800 - 1,200



188
Johann Krauss Helmet-and-chest-piece Lighting Stand-in +A
Hellboy II: The Golden Army (2008)

A Johann Krauss helmet-and-chest-piece lighting stand-in from Guillermo del Toro's superhero sequel Hellboy II: The Golden Army. Krauss was an ectoplasmic being who piloted a custom-made suit. He was voiced by Seth MacFarlane and the suit was controlled by John Alexander and James Dodd. This item was used to work out lighting positions without the need for the hero suit to be on set.

The chest piece is predominantly made of foam rubber painted to look like bronze, while the helmet dome is clear acrylic. They sit on a grey biscuit-foam-and-resin bust with "183cm" handwritten on both sides. The dome has some scuffing, and the foam rubber has cracked in some places. Dimensions: 44 cm x 48 cm x 60 cm (17 1/4" x 19" x 23 1/2")

Estimate. £3,000 - 5,000

189
Pinhead (Doug Bradley) Lifecast with Original Filming Prosthetics M
Hellraiser (1987)

A Pinhead (Doug Bradley) lifecast with original filming skin and nails prosthetics from the production of Clive Barker's seminal horror film Hellraiser. The lead Cenobite, commonly known as Pinhead, tormented anyone who activated the Lament Configuration puzzle box and dragged them back to his hellish dimension. Pinhead is one of the most iconic horror movie antagonists and is easily identified by his nail-covered face and his BDSM-inspired black leather costume.

This lifecast of actor Doug Bradley was made during the production, and has been finished with original make-up prosthetics, including skin and custom-crafted metal nails, which were filmed with during the production. Original Pinhead make-up appliances are incredibly rare and this is thought to be one of the last surviving sets. The lifecast is made of resin and fibreglass and is fixed to a custom-made display stand. The prosthetics have some wear from age, including some minor cracks and small holes, and one of the skin sections has slipped slightly. Dimensions (display): 26 cm x 24 cm x 48.5 cm (10 1/4" x 9 3/4" x 19")

Estimate. £12,000 - 16,000



190
Lament Configuration Puzzle Box m
Hellraiser (1987)

A Lament Configuration puzzle box from Clive Barker's horror film Hellraiser. Essential to the film's plot, the Lament Configuration puzzle box created a gateway to a dimension of suffering and summoned the demonic Cenobites. Frank Cotton (Sean Chapman) purchased the box at the beginning of the film, and it was eventually taken from him by Kirsty (Ashley Laurence), who banished the Cenobites by closing the box. This lot originally came from the collection of special make-up effects artist Simon Sayce.

One of eight boxes produced for the film, the box is made of solid oak and decorated with ornate, brass-etched panels adhered to each side. A layer of varnish is applied all over to produce a slight shine. There are some signs of light scratching, the brass etchings have broken in some places, and the brass has tarnished in spots. Dimensions: 7.5 cm x 7.5 cm x 7.5 cm (3" x 3" x 3")

Estimate. £10,000 - 15,000





191
 Pinhead (Doug Bradley) Cenobite Costume and Facial Prosthetics M
Hellraiser VI: Hellseeker (2002)

Pinhead's (Doug Bradley) Cenobite costume and facial prosthetics from Rick Bota's horror sequel Hellraiser: Hellseeker. Pinhead's ghoulish visage was seen throughout the film as Trevor (Dean Winters) used the sinister Lament Configuration puzzle box, not knowing it bridged the gap between Earth and hell.

The costume features a foam-latex bodysuit that is primarily painted black, with sections at the front painted to look like exposed and cut flesh, and padding to give an unnatural shape to Bradley's musculature. The costume also comprises a black cotton skirt with a waist tie; a black sequined cotton apron with a waist tie; and three Cenobite torture knives made of plastic with wooden handles. The knives are distressed, with scratches on the wood and heavy amounts of stage blood on the blades.

The full-face latex prosthetic comes presented on a foam-rubber bust of Bradley's face. The make-up is painted white with dull pink in its chequered crevices, and features 68 gold-painted plastic nails. A letter from make-up artist Gary J. Tunncliffe also accompanies the lot. Dimensions (bust): 40 cm x 27 cm x 19 cm (15 3/4" x 10 1/2" x 7 1/2"); (longest knife): 38.5 cm x 4 cm x 0.5 cm (15" x 1 1/2" x 1/4")

Estimate. £8,000 - 12,000



192
 Kili's (Aidan Turner) Sword M
Hobbit, The: The Battle Of The Five Armies (2014)

Kili's (Aidan Turner) sword from Peter Jackson's fantasy adventure prequel The Hobbit: The Battle of the Five Armies. Kili took his sword from the armoury in the Lonely Mountain and wielded it during the Battle of the Five Armies at the climax of the film. It was most notably seen during his fight with the orc Bolg (John Tui) while he attempted to avenge the death of his brother Fili (Dean O'Gorman).

This hard rubber sword features a broad blade, painted silver with a jagged tip and a geometric motif running down its inner channels. The weapon's hilt comprises a woven leather-effect grip, painted dark purple, and an asymmetric guard and angular pommel painted in a gold tone. Varnish has been applied to make the weapon appear aged, and the blade exhibits a repaired broken tip. Dimensions: 104.5 cm x 11 cm x 5 cm (41 1/4" x 4 1/4" x 2")

Estimate. £6,000 - 8,000

193
 Lindsay Anderson's Palme d'Or
 Cannes Film Festival Best Film
 Award 1969 Ω
If... (1968)

Lindsay Anderson's Grand Prix du Festival International du Film, now known as the Palme d'Or - the highest prize of the Cannes Film Festival - awarded for best movie in 1969 for if...

if... was Lyndsay Anderson's controversial satire on life in an English boys boarding school, starring Malcolm McDowell in the role of Mick Travis. It is still regarded as one of the best British movies of all time.

The prestigious Cannes award, unheard of in private ownership, was subsequently awarded to a young Irish filmmaker in London in the 1970s as a first prize in a competition for amateur short films. His film, A.R.F.A. (Automated Robotronic Footballing Assembly), was filmed at a local football stadium and shot in Super 8. Given the notorious issues with sound recording on those cameras, a unique way of syncing sound and pictures was developed. The sound was recorded separately on reel-to-reel and added manually to the footage, matching the sound by slowing the projector spools by hand - quite the technical achievement.

The Palme d'Or is made from terracotta and is inscribed "1969 Cannes festival international du film". The legendary golden palm itself is made of yellow metal, is stamped with French strike marks and is missing a frond. The leaf was originally designed by Parisian jeweller Lucienne Lazon from a sketch by Jean Cocteau, who drew his inspiration from the "Promenade de la Croisette" in Cane, which is lined with tall trees. The stem of the golden leaf finishes in the shape of a heart.

There is a small chip to the top edge and the thumb, on the open palm, is missing. There is a hole at the base where the award was previously displayed. Dimensions: 15 x 9.5 x 5 cm (6" x 3 3/4" x 2")

Estimate. £10,000 - 15,000

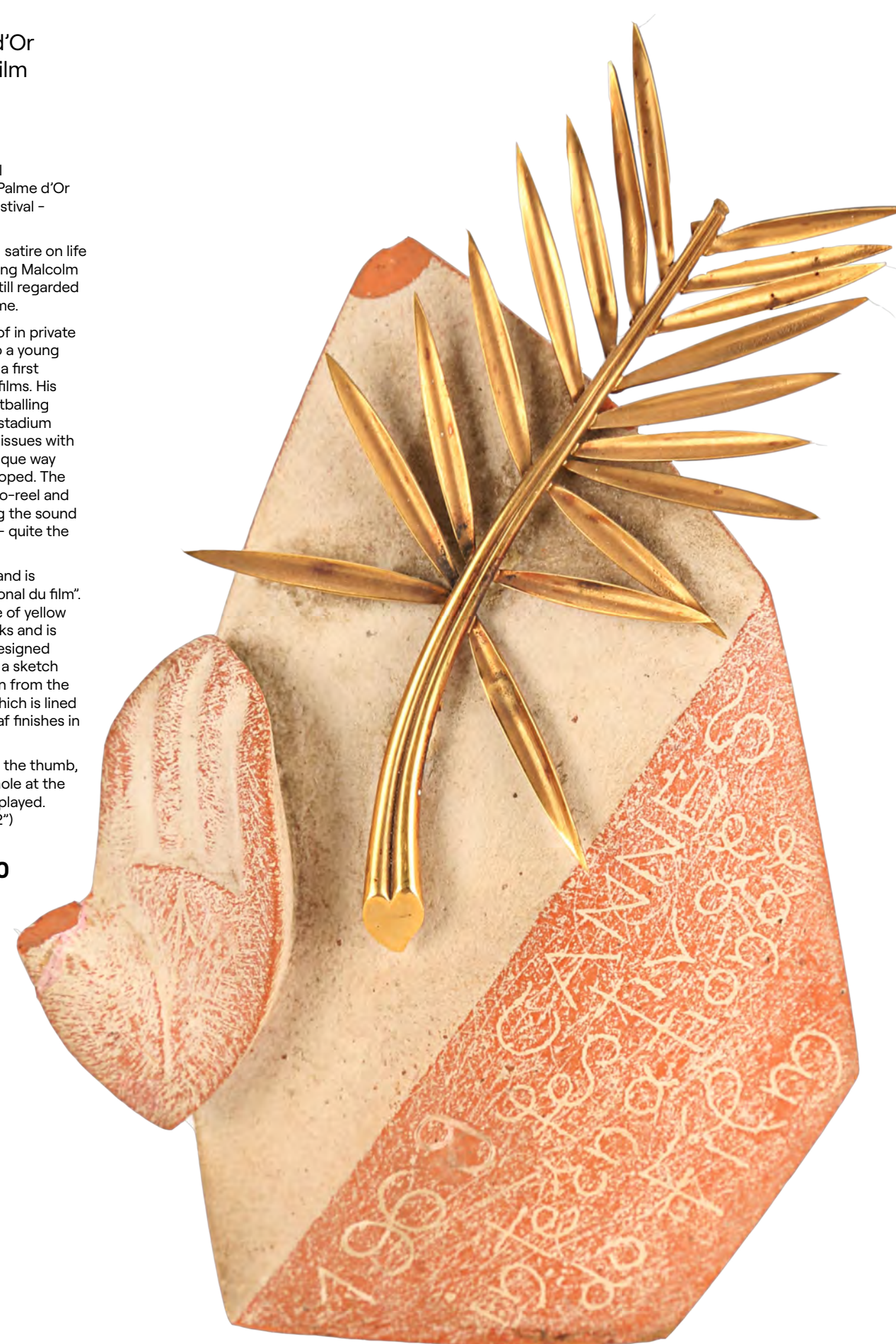

194
 Captain Hook's Stunt Sword Ω
Hook (1991)

Captain Hook's stunt sword from Steven Spielberg's fantasy adventure film Hook. Once Peter Banning (as played by Robin Williams) returned to save his children, Hook (as played by Dustin Hoffman) brandished his sword to challenge his nemesis.

This sword features a rubber blade hand-painted silver and moulded around a thin metal rod, as well as a gold-colour resin handguard with a red rubber cover. The tip of the sword is broken off, exposing the metal and rod, and it exhibits chips in the handguard, and scratches and scuffs in the paint from production. Dimensions: 68.75 cm x 15.25 cm x 10.25 cm (27" x 6" x 4")

Estimate. £3,000 - 5,000



195
 Tinkerbell's Costume Ω
Hook (1991)

Tinkerbell's costume from Steven Spielberg's fantasy adventure film Hook. Tinkerbell (as played by Julia Roberts) wore her simple-made fairy garments throughout the film.

This costume consists of a shirt and a pair of short trousers with a satin-covered elastic waistband. Constructed of unlined brown suede leather, it features stitching along the seams with colourful suede lacing, leaf-like cutouts on the collar and hems, and a suede-leaf on the end of the lace string. The top also features a tag for "Julia Reg. 3" and the short trousers have a tag for "Julia 7-5." Production intentionally created open seamed holes in the back of the top and the side of bottoms for wire work. This costume exhibits mild discoloration and scratching in the leather.

Estimate. £3,000 - 5,000



196
 Lost Boys Armour Ω
Hook (1991)

A set of Lost Boys armour from Steven Spielberg's fantasy adventure film Hook. The Lost Boys suited up in makeshift armour for their war with the pirates. This full set of body armour, constructed out of reed fencing and rope, features hand-painted designs, snail shell adornments with green trails, a bamboo neckline, and dirt-filled resin pineapple halves as pauldrons. The inside of the armour features markings on tape to denote the front and back, as well as a tag for "28. Frankie Hill." Production purposefully distressed this armour. This costume exhibits some fractured reeds and loose dirt.

Estimate. £1,000 - 1,500



197
 Lost Boys Helmet Ω
Hook (1991)

A Lost Boys helmet from Steven Spielberg's fantasy adventure film Hook. The Lost Boys suited up in makeshift armour for their war with the pirates. This lot consists of one helmet made of foam, fronds, cloth, and ostrich feathers, featuring a gourd-like shape and hand-painted designs resembling a chicken's face. The ostrich feathers have been dyed blue. This lot exhibits notable glue marks along the fronds, flaking paint, and fragile foam beneath the outer shell of the helmet. Dimensions: 30.5 cm x 25.5 cm x 48.5 cm (12" x 10" x 19")

Estimate. £1,000 - 1,500

198
The Grinch's (Jim Carrey) Light-Up Full-Size Sleigh us
How The Grinch Stole Christmas (2000)

The Grinch's (Jim Carrey) light-up full-size sleigh from Ron Howard's holiday comedy *How the Grinch Stole Christmas*. The Grinch had a change of heart after stealing all of the Christmas presents in Whoville, saving them, along with Cindy Lou Who (Taylor Momsen), from falling off Mount Crumpit on his enormous sleigh.

Based on the original illustrations of Dr. Seuss and acquired from Universal by Arizona Picture Cars after production concluded, this oversized, multi-media sleigh is thought to be one of only two full-size sleighs created by production for use in the climactic sequence. It features a combination of found objects and electronic elements surrounding an inflatable red velvet-lined Santa-style gift sack centrepiece designed to appear constructed from patchwork.

The sleigh's base is constructed from metal with various electronics, including fans, hair dryers, false piping, and a medley of functional head and front lights, affixed to the front. The top features a grated metal seat with a steering mechanism for the performer. The sack is wrapped with various Whoville decor, including a pink plastic toy tricycle with a missing wheel, a sign hand-painted "Merry Merry" by production, strands of green, gold, and silver tinsel, glittering plastic tree ornaments, and a dangling bushel of prop bananas. The sack inflates automatically on low, medium, or high settings via a 110v power plug concealed amidst the machinery.

Following production, this sleigh was decommissioned and its propane tanks were emptied by Ghost Ride Productions. It was also mounted to a removable metal tongue for transportation. The sleigh's other mechanics are intentionally distressed to appear rusty and well-used, and it exhibits bent metal, scratching, and staining throughout from use by production and as a Christmas display following filming. As this lot ships directly from New York, shipping must be arranged with Propstore prior to bidding. Dimensions: 549 cm x 183 cm x 640 cm (216" x 72" x 252")

Special shipping required; see notice in the Buyer's Guide.

Contains electronic components; see notice in the Buyer's Guide.

Estimate. £20,000 - 30,000



6.4 m (21')



2.5cm (1")

2.5cm (1")



199
Cobb's (Leonardo DiCaprio)
Spinning Top Totem M
Inception (2010)

Cobb's (Leonardo DiCaprio) spinning top totem from Christopher Nolan's sci-fi thriller Inception. Cobb used his totem to distinguish whether he was in the dream world or reality. The totem is made of tarnished steel, and was handcrafted for the film. Dimensions: 2.5 cm x 2.5 cm x 2.5 cm (1" x 1" x 1")

Estimate. £4,000 - 6,000



200
Cobb's (Leonardo DiCaprio)
Passport M
Inception (2010)

Cobb's (Leonardo DiCaprio) passport from Christopher Nolan's sci-fi action film Inception. Cobb, a thief who steals corporate secrets through the use of dreams, used his passport to re-enter the United States during the film's finale.

This blue passport includes 14 detailed pages, including a data page featuring an image of Cobb, his personal details and signature, and a number of visa stamps from various countries. Dimensions: 12.5 cm x 9 cm x 0.4 cm (5" x 3 1/2" x 1/4")

Estimate. £3,000 - 5,000



201
Lieutenant Aldo Raine's (Brad Pitt) Uniform M
Inglourious Basterds (2009)

Lieutenant Aldo Raine's (Brad Pitt) uniform from Quentin Tarantino's 2009 World War II film Inglourious Basterds. Raine wore the uniform while delivering a speech motivating his men to kill Nazis.

The uniform features a thick brown woolen jacket (size 48R, labelled "Hero Collection") with a First Lieutenant's single silver bar on each shoulder and a red "USA Canada" First Special Service Force shoulder patch on the left shoulder. The uniform also comprises a russet short-sleeved shirt (size S, labelled "Rock-It") whose collar is adorned in two places with the First Special Service Force insignia of crossed arrows; a pair of khaki jumpsuit trousers with large pockets and ties around the legs; and a brown leather belt with a silver-coloured buckle.

Estimate. £10,000 - 15,000

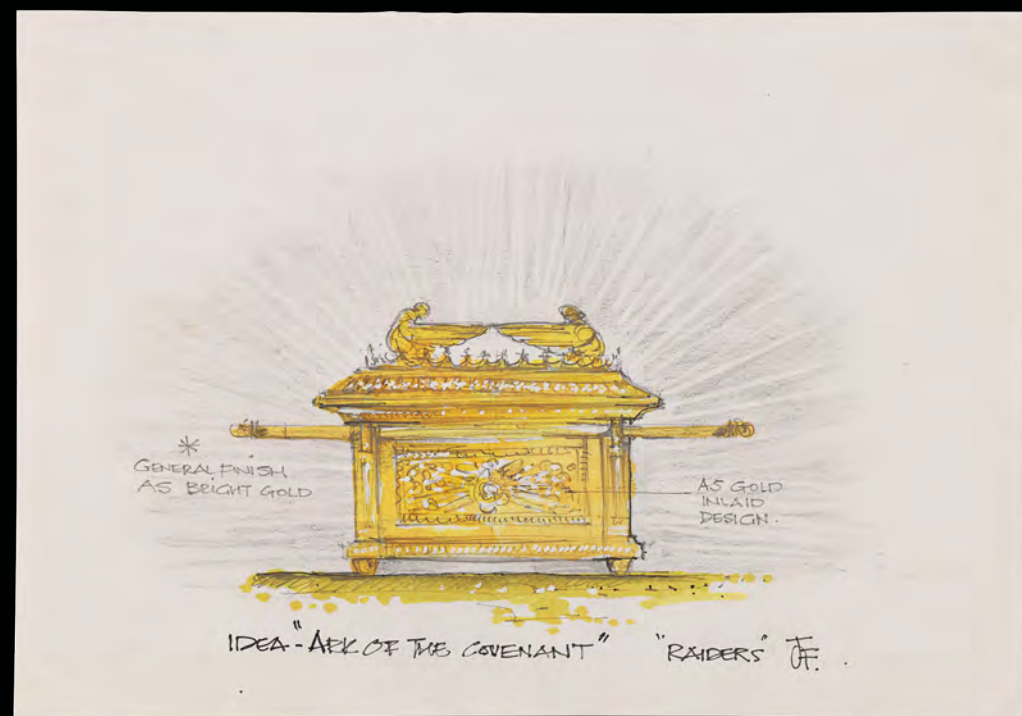

29.5cm (11.5")

202
 Hand-drawn and Coloured Ark of the Covenant Production Illustration M
Indiana Jones And The Raiders Of The Lost Ark (1981)

A hand-drawn and coloured Ark of the Covenant production illustration from the production of Steven Spielberg's action-adventure film Raiders of the Lost Ark. Indiana Jones (Harrison Ford) raced against the Nazis to find the legendary lost Ark of the Covenant.

This concept art is rendered in pencil, ink and watercolour on paper. It features the golden Ark, a couple of pencil notes, and "Idea - 'Ark of the Covenant' 'Raiders'" handwritten in ink beneath the piece. The artwork was drawn by assistant art director John Fenner, who has initialled it at the bottom right. This early design closely resembles what was ultimately seen in the film, with other designs by artists such as Joe Johnston not being as close to the final film version as this one. The page has only very minor staining and edge wear. Dimensions: 20.5 cm x 29.5 cm (8" x 11 1/2")

Sold without copyright; see copyright notice in the Buyer's Guide.

Estimate. £4,000 - 6,000

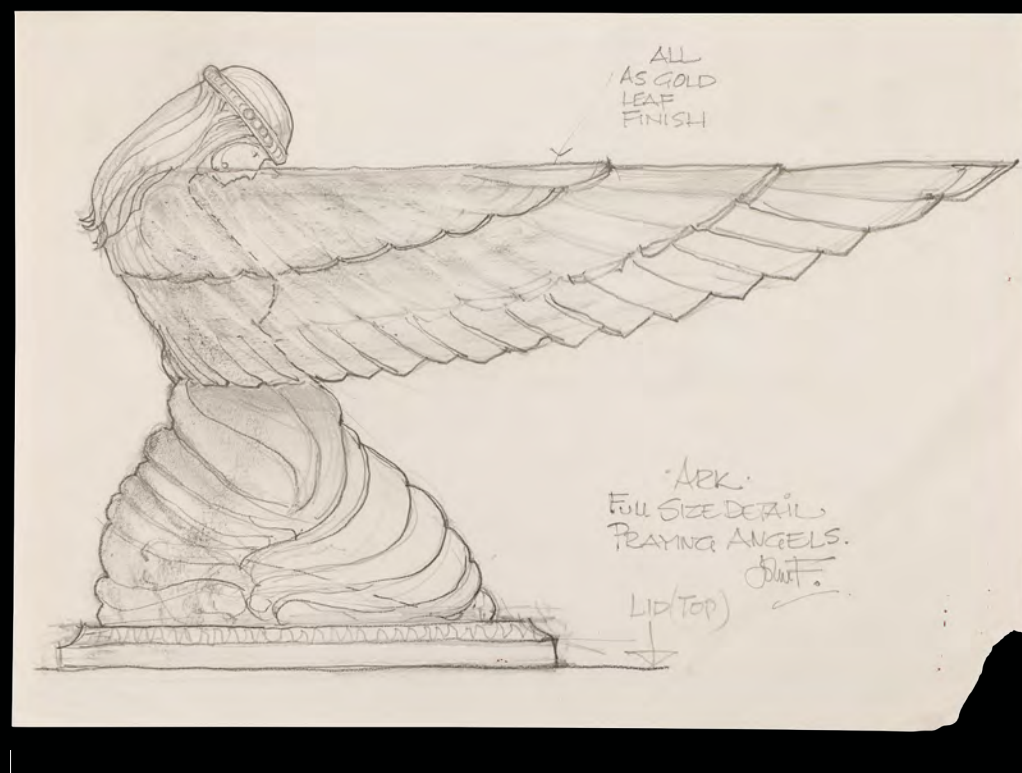

29.5cm (11.5")

203
 Hand-drawn Angel of the Ark of the Covenant Pencil Production Illustration M
Indiana Jones And The Raiders Of The Lost Ark (1981)

A hand-drawn angel of the Ark of the Covenant production illustration from the production of Steven Spielberg's action-adventure film Raiders of the Lost Ark. Indiana Jones (Harrison Ford) raced against the Nazis to find the legendary lost Ark of the Covenant.

This concept art is rendered in pencil on paper and features a drawing of one of the angels that adorns the top of the Ark. It also displays a couple of design notes, with "Ark - Full Size Detail - Praying Angels" handwritten next to the piece. The artwork was drawn by assistant art director John Fenner, who has initialled it at the bottom right. This early design closely resembles what was ultimately seen in the film, with other designs by artists such as Joe Johnston not being as close to the final film version as this one. The bottom right corner of the page is missing. Dimensions: 21 cm x 29.5 cm (8 1/4" x 11 1/2")

Sold without copyright; see copyright notice in the Buyer's Guide.

Estimate. £3,000 - 5,000

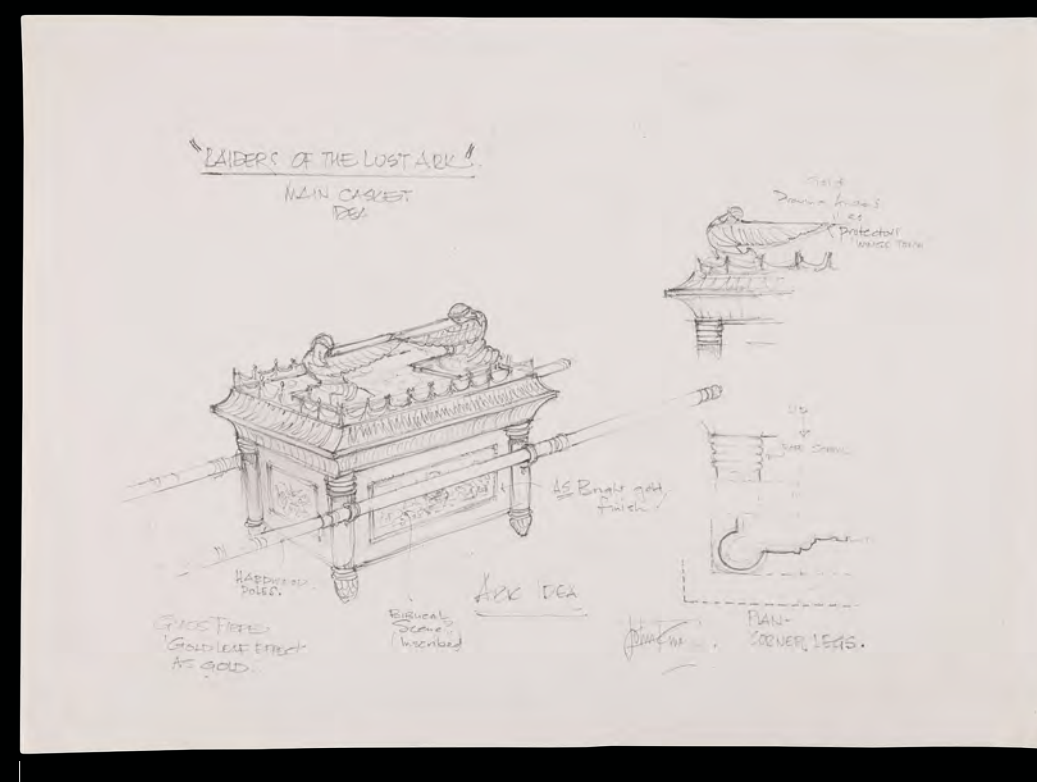

40cm (15.75")

204
 Hand-drawn Ark of the Covenant Pencil Production Illustration M
Indiana Jones And The Raiders Of The Lost Ark (1981)

A hand-drawn Ark of the Covenant production illustration from the production of Steven Spielberg's action-adventure film Raiders of the Lost Ark. Indiana Jones (Harrison Ford) raced against the Nazis to find the legendary lost Ark of the Covenant.

This concept artwork is rendered in pencil on paper and features a drawing of the "Main Casket Idea", with two detailed sketches - one showing the praying angel figurines on the Ark's lid, and the other depicting a set of curved corner legs. It also displays handwritten design notes and construction annotations, such as "Glass Fibre, Gold Leaf Effect As Gold", "Hardwood Poles" and "Biblical Scene? (Inscribed)". This artwork was drawn by assistant art director John Fenner. This early design closely resembles what was ultimately seen in the film, with other designs by artists such as Joe Johnston not being as close to the final film version as this one. The page exhibits minor creasing. Dimensions: 29.5 cm x 40 cm (11 1/2" x 15 3/4")

Sold without copyright; see copyright notice in the Buyer's Guide.

Estimate. £4,000 - 6,000



205
 Aluminium Thuggee Guard Sword O
Indiana Jones And The Temple Of Doom (1984)

An aluminium thuggee guard sword from Steven Spielberg's action adventure sequel Indiana Jones and the Temple of Doom. Mola Ram's (Amrish Puri) Kali-worshipping cultists carried swords throughout the film, including when they trapped Indiana Jones (Harrison Ford) on a rickety rope bridge. This sword features an aluminium blade with a long ridge down the side screwed into a fibreglass grip painted silver and gold-colour and wrapped with gold-colour wire. This lot exhibits chipped paint and heavy nicking along the blade's edge. Dimensions: 106.75 cm x 5.25 cm x 5.25 cm (42" x 2" x 2")

Estimate. £3,000 - 5,000

206

Peter Nelson Collection: Legal Title for Ownership and Use of UK "J 8OND"
Licence Plate M

James Bond Collectibles

The legal title for ownership and use of the UK licence plate "J8 OND". By securing this lot, you secure legal ownership of, and the right to use, this unique and sought-after personalised number plate, based on the name of Ian Fleming's iconic character James Bond.

The lot includes two 'presentation' number plates - front and rear - made of acrylic. DVLA transfer will be arranged for the winning bidder, and it will be their responsibility to provide legal plates for their vehicle. It is worth noting that the numberplate "JB 007" sold at auction in 2015 for £240,000. Dimensions (each): 52 cm x 11 cm x 0.5 cm (20 1/2" x 4 1/4" x 1/4")

Estimate. £80,000 - 120,000



Tom Wood / Alamy Stock Photo



Tom Wood / Alamy Stock Photo

For illustrative purposes only - DB5 Vehicle is not part of this lot





207
£50 Le Cercle Casino Plaque †Δ
James Bond: Dr. No (1962)

A £50 Le Cercle casino plaque from Terence Young's Bond movie Dr. No. Gaming plaques and chips were used at Le Cercle casino, where Agent 007 (Sean Connery) memorably introduced himself with the immortal line, "Bond, James Bond." The production used original plaques loaned by Le Cercle casino at Les Ambassadeurs Club.

The plaque is made of plastic and has a yellow pearlescent finish. One side features "Le Cercle", "£50" and a unicorn decoration, and is stamped "0025". The reverse shows "£50", "Les Ambassadeurs Club" and a black picture of the club itself. The plaque has warped slightly with age but displays minimal wear. As it is not possible to screen-match this plaque among the many required on set, we are unable to verify if this particular prop was one used for filming. Dimensions: 6.5 cm x 9 cm x 0.5 cm (2 1/2" x 3 1/2" x 1/4")

Estimate. £3,000 - 5,000



208
£100 Le Cercle Casino Plaque †Δ
James Bond: Dr. No (1962)

A £100 Le Cercle casino plaque from Terence Young's Bond movie Dr. No. Gaming plaques and chips were used at Le Cercle casino, where Agent 007 (Sean Connery) memorably introduced himself with the immortal line, "Bond, James Bond." The production used original plaques loaned by Le Cercle casino at Les Ambassadeurs Club.

The plaque is made of plastic and has a bright pink pearlescent finish. One side features "Le Cercle", "£100" and a unicorn decoration, and is stamped "0132". The reverse shows "£100", "Les Ambassadeurs Club" and a black picture of the club itself. The plaque has warped slightly with age. As it is not possible to screen-match this plaque among the many required on set, we are unable to verify if this particular prop was one used for filming. Dimensions: 7 cm x 10.5 cm x 0.5 cm (2 3/4" x 4 1/4" x 1/4")

Estimate. £3,000 - 5,000



209
£500 Le Cercle Casino Plaque †Δ
James Bond: Dr. No (1962)

A £500 Le Cercle casino plaque from Terence Young's Bond movie Dr. No. Gaming plaques and chips were used at Le Cercle casino, where Agent 007 (Sean Connery) memorably introduced himself with the immortal line, "Bond, James Bond." The production used original plaques loaned by Le Cercle casino at Les Ambassadeurs Club.

The plaque is made of plastic and has a green pearlescent finish. One side features "Le Cercle", "£500" and a unicorn decoration, and is stamped "0050". The reverse shows "£500", "Les Ambassadeurs Club" and a black picture of the club itself. The plaque has warped slightly with age. As it is not possible to screen-match this plaque among the many required on set, we are unable to verify if this particular prop was one used for filming. Dimensions: 8 cm x 11.5 cm x 0.5 cm (3 1/4" x 4 1/2" x 1/4")

Estimate. £3,000 - 5,000

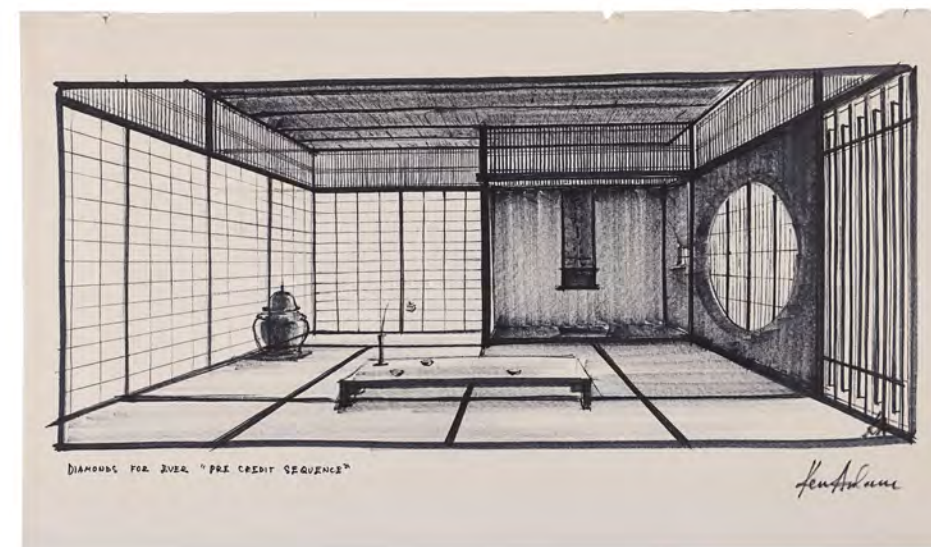

210
Original Ken Adam Pre-credit
Sequence Production Design
Autographed by Adam †Δ
James Bond: Diamonds Are Forever
(1971)

An original piece of set design artwork by acclaimed production designer Ken Adam, from the production of Guy Hamilton's Bond film Diamonds Are Forever. The design is hand-drawn in pencil and signed by Adam. Sir Kenneth Adam made his name as a production designer on the Bond films of the 60s and 70s, as well as other classics such as Dr. Strangelove. Adam won two Academy Awards® for Best Art Direction in his career, for Barry Lyndon and The Madness of King George.

The design is titled "Diamonds For Ever [sic]; Pre Credit Sequence" and concerns the scene when Bond searched for Ernst Stavro Blofeld (Charles Gray) in Japan. Rendered on paper in black ink, Adam has also signed the design in the bottom right. The design was originally sold in the "Design of the Times" auction at Sotheby's in March 2003. The artwork is slightly frayed on its upper edge. Dimensions: 53.5 cm x 32 cm (21" x 12 1/4")

Sold without copyright; see notice in the Buyer's Guide.

Estimate. £3,000 - 5,000



211
STEN Mk. II Replica Sub-machine Gun M
James Bond: Dr. No (1962)

A STEN Mk. II replica sub-machine gun from Terrence Young's Bond film Dr. No. Dr. Julius No's (Joseph Wiseman) guards carried STEN Mk. I and Mk. II sub-machine guns while patrolling the beaches of his island Crab Key. James Bond (Sean Connery) notably drowned a guard carrying a STEN Mk. II to prevent his discovery.

The weapon is a replica STEN Mk. II sub-machine gun made to be used as an on-screen production prop and cannot chamber or fire any rounds of ammunition. This model was the second-most produced sub-machine gun of World War II, and was used extensively by the British and Commonwealth forces. Made from blackened soft metal, it features a magazine clip at a 90-degree angle on the left, three sets of three evenly spaced holes along the barrel sleeve, and a single strut stock that angles down. The gun can be field stripped, cocked and fully disassembled. It features a manufacturer's stamp on the magazine slot reading, "STEN Mk II CMC NO A0386". The item exhibits extensive rusting from age. Dimensions: 74 cm x 30 cm x 14 cm (29 1/4" x 11 3/4" x 5 1/2")

From the personal collection of Peter Nelson, previously displayed at his two museums, The Cars of the Stars and The Bond Museum in Keswick, Cumbria, until they closed in 2011.

Restricted ownership; see replica firearm notice in the Buyer's Guide.

Estimate. £3,000 - 5,000





212
Peter Nelson Collection: Hotel Fontainebleau Table, Two Chairs and Sun Lounger M
James Bond: Goldfinger (1964)

A Hotel Fontainebleau table, two chairs and a sun lounger from Guy Hamilton's Bond film Goldfinger. James Bond (Sean Connery) met Felix Leiter (Cec Linder) at the Hotel Fontainebleau in Miami, where Leiter pointed out bullion dealer Auric Goldfinger (Gert Fröbe), enabling Bond to subsequently derail Goldfinger's gin rummy ruse. The pool area of the hotel was filled with tables, chairs and sun loungers.

The chairs and sun lounger have metal frames with wooden slats which are painted white. The sun lounger's padded cushion is blue and features several patches and small areas of repair. The fold-down table is made of wood and features white legs and a blue top. Dimensions (each chair): 55 cm x 53 cm x 78 cm (21 3/4" x 20 3/4" x 30 3/4")

From the personal collection of Peter Nelson, previously displayed at his two museums, "The Cars of the Stars" and "The Bond Museum" in Keswick, Cumbria, until they closed in 2011.

Special shipping required; see special shipping notice in the Buyer's Guide.

Estimate. £4,000 - 6,000



Propstore

Entertainment Memorabilia Live Auction

Treasures from Film and Television



Summer 2023



Star Wars: A New Hope (1977)
Screen-Matched ILM Red Leader X-wing Model Miniature

sold for \$2,375,000 (£1,938,000)





Snap/Shutterstock



Moviestore/Shutterstock



213
James Bond's (Sean Connery) Screen-matched Little Nellie Pilot Helmet m
James Bond: You Only Live Twice (1967)

James Bond's (Sean Connery) screen-matched Little Nellie pilot helmet from Lewis Gilbert's Bond film *You Only Live Twice*. Bond wore his helmet while flying the autogyro dubbed "Little Nellie" to find Blofeld's (Donald Pleasence) hidden base. It matches the one worn by Connery on-screen through the lens serial number and a small chip on the left side of the helmet's metal cinecamera.

Two helmets were made for the production, one worn by Connery for close-ups and one worn by the autogyro stunt pilot, Wing Commander Ken Wallis. Both ended up in Wallis' possession after the production and there are subtle differences between the two, including the shape of the cinecamera and the size of its lens. After production, the helmet was painted black, but it has since been sympathetically restored.

The helmet is made of white plastic with foam padding around the interior. Headphones rest over the ears and a microphone sits across the mouth. A cotton chin-strap is attached between the two headphones. The helmet is displayed on a custom-made stand and is accompanied by a letter detailing the history of the item and a loan agreement between EON Productions and the vendor for the loan of the helmet to the Bond in Motion exhibition in Covent Garden. The helmet was also put on display in a Selfridges shop window on Oxford Street, London, to help promote the film's release in 1967.

Estimate. £60,000 - 100,000





214
 Peter Nelson Collection: James Bond's (George Lazenby) Throwing Knife M
James Bond: On Her Majesty's Secret Service (1969)

James Bond's (George Lazenby) throwing knife from Peter R. Hunt's Bond film On Her Majesty's Secret Service. After being brought to Draco's (Gabriele Ferzetti) office at gunpoint, Bond threw his knife at a calendar on Draco's bookcase, piercing the date 14 September. Draco commented, "But today is the thirteenth, Commander," to which Bond replied, "I'm superstitious".

The knife features a steel blade with a faint engraving that reads "WHITBY Solingen Germany" and a dark wooden handle. It is presented in a brown leather Solingen sheath. The lot exhibits nicks and scratches from production use and age. Dimensions (with sheath): 27.5 cm x 4.5 cm x 2.5 cm (10 3/4" x 1 3/4" x 1")

From the personal collection of Peter Nelson, previously displayed at his two museums, "The Cars of the Stars" and "The Bond Museum" in Keswick, Cumbria, until they closed in 2011.

Estimate. £6,000 - 8,000

215
 Peter Nelson Collection: Henchmen Stunt Rifle M
James Bond: On Her Majesty's Secret Service (1969)

A henchman stunt rifle from Peter R. Hunt's Bond film On Her Majesty's Secret Service. The SPECTRE guards and Blofeld's (Telly Savalas) henchmen at the Alpine institute atop Piz Gloria all carried rifles, and notably used them during the ski chase as they tried to prevent Bond's (George Lazenby) escape.

This stunt weapon is based on the SIG SG 550 rifle and is made mostly of cast hollow resin with a blacked steel barrel tip and a brown leather body strap. The main body is painted metallic green, with the handle and butt painted black. It features a pressable button situated on the handle below a movable trigger. The item exhibits wear from production use and age, including several cracks, paint wear and a hole in the underside of the barrel. Dimensions: 117 cm x 7 cm x 25.5 cm (46" x 2 3/4" x 10")

Additional Provenance: From the personal collection of Peter Nelson, previously displayed at his two museums, The Cars of the Stars and The Bond Museum in Keswick, Cumbria, until they closed in 2011.

Restricted ownership; see replica firearm notice in the Buyer's Guide.

Estimate. £3,000 - 5,000

216
 "The Lovers" Tarot Card M
James Bond: Live And Let Die (1973)

A "The Lovers" tarot card from Guy Hamilton's Bond film Live and Let Die. Solitaire (Jane Seymour), Kananga's (Yaphet Kotto) psychic, used tarot cards to predict the future. Bond (Roger Moore) used a stacked deck to convince Solitaire they were fated to be together.

The card features a pair of entwined lovers on the front and a red-and-white pattern that incorporates "007" on the back. The front has some minor staining and the back has three small patches where the pattern has come away. Dimensions: 11 cm x 7 cm (4 1/4" x 2 3/4")

Estimate. £3,000 - 5,000

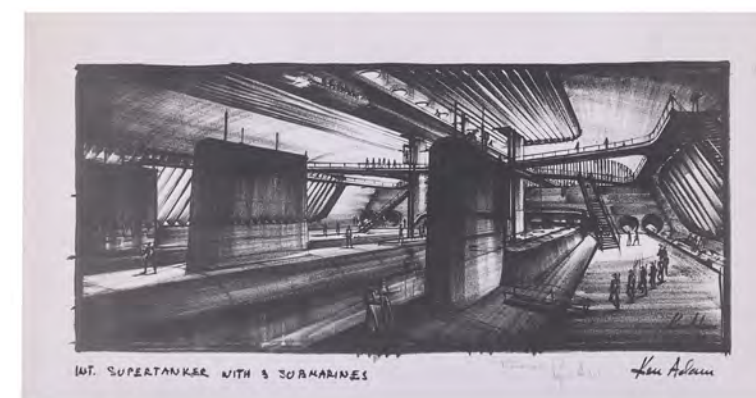
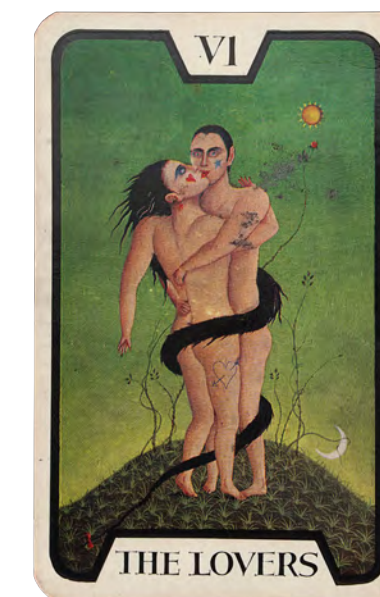
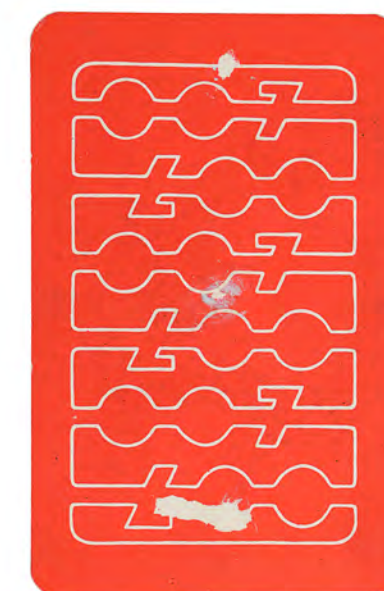

217
 Ken Adam Liparus Supertanker with Three Submarines Production Design Autographed by Roger Moore and Ken Adam †Δ
James Bond: The Spy Who Loved Me (1977)

A production copy of the Ken Adam-designed Liparus supertanker autographed by Roger Moore and acclaimed production designer Adam, from the production of Lewis Gilbert's Bond film The Spy Who Loved Me. The villainous Karl Stromberg's (Curt Jürgens) supertanker Liparus was discovered by Bond (Roger Moore) to be a submarine dock.

Sir Kenneth Adam made his name as a production designer on the Bond films of the 60s and 70s, as well as other classics such as Dr. Strangelove. Adam won two Academy Awards® for Best Art Direction in his career, for Barry Lyndon and The Madness of King George.

Printed on cartridge paper, the design shows the inside of the Liparus and three docked submarines. "Int. Supertanker with 3 Submarines" is handwritten by Adam in black ink below. Adam has also signed the design at the bottom right, while Moore has inscribed "Thank you" with his autograph. The design was originally sold in the "Design of the Times" auction at Sotheby's in March 2003. Dimensions: 30.5 cm x 58 cm (12" x 22 3/4")

Estimate. £2,000 - 3,000

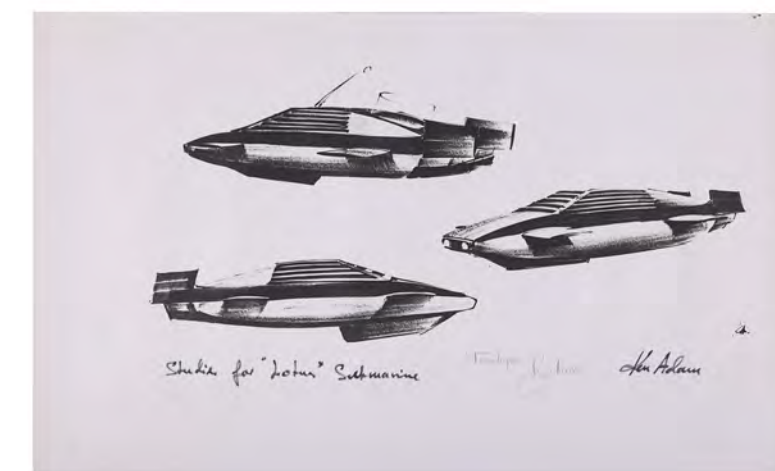

218
 Ken Adam Lotus Submarine Production Design Autographed by Roger Moore and Ken Adam †Δ
James Bond: The Spy Who Loved Me (1977)

A production copy of the iconic Ken Adam-designed Lotus submarine autographed by Roger Moore and acclaimed production designer Adam, from the production of Lewis Gilbert's Bond film The Spy Who Loved Me. James Bond (Moore) drove a Lotus Esprit, which converted into a submarine.

Sir Kenneth Adam made his name as a production designer on the Bond films of the 60s and 70s, as well as other classics such as Dr. Strangelove. Adam won two Academy Awards® for Best Art Direction in his career, for Barry Lyndon and The Madness of King George.

Printed on cartridge paper, the design shows the Lotus from three different angles and has "Studies for 'Lotus' Submarine" handwritten by Adam in black ink below. Adam has also signed the design at the bottom right, while Moore has inscribed "Thank you" with his autograph. The design was originally sold in the "Design of the Times" auction at Sotheby's in March 2003. Dimensions: 36 cm x 58 cm (14 1/4" x 22 3/4")

Estimate. £1,500 - 2,500



219
 Peter Nelson Collection:SFX
 Octopus Puppet M
James Bond: Octopussy (1983)

An SFX octopus puppet from John Glen's Bond film Octopussy. Smuggler Octopussy (Maud Adams) owned a blue-ringed octopus which doubled as the symbol of her organisation. During a fight between Octopussy, Bond (Roger Moore) and Kamal Khan's (Louis Jourdan) men, one of Khan's thugs was thrown into the aquarium, where the octopus latched onto his face.

The puppet is made of rubber and is hand-painted to resemble the real animal's intricate patterning as closely as possible. The puppet's paintwork remains in a fragile condition and has flaked off in some areas. Dimensions: 55 cm x 50 cm x 8 cm (21 3/4" x 19 3/4" x 3 1/4")

From the personal collection of Peter Nelson, previously displayed at his two museums, "The Cars of the Stars" and "The Bond Museum" in Keswick, Cumbria, until they closed in 2011.

Estimate. £2,000 - 3,000



220
 Peter Nelson Collection: Miss
 Moneypenny's (Lois Maxwell) Hat M
James Bond: A View To A Kill (1985)

Miss Moneypenny's (Lois Maxwell) hat from John Glen's Bond film A View to a Kill. Miss Moneypenny wore her flowered hat during the Ascot races that she attended with Bond (Roger Moore), M (Robert Brown), Q (Desmond Llewlyn) and Sir Godfrey Tibbett (Patrick Macnee).

The wide brim woven straw hat has a pink binding around the brim and features an array of white and pink imitation flowers sewn into the top of the head and around the front of the inner headband. It includes a John Boyd brand label on the interior. Accompanying this hat is a laminated still of Miss Moneypenny, Bond, M and Q on set. Dimensions: 48 cm x 48 cm x 14 cm (19" x 19" x 5 1/2")

From the personal collection of Peter Nelson, previously displayed at his two museums, "The Cars of the Stars" and "The Bond Museum" in Keswick, Cumbria, until they closed in 2011.

Estimate. £3,000 - 5,000



221
 James Bond's (Pierce Brosnan) Suit Display M
James Bond: Goldeneye (1995)

James Bond's (Pierce Brosnan) three-piece suit from Martin Campbell's Bond movie GoldenEye. Bond wore his Brioni suit as he came face-to-face with his old ally Alec Trevelyan (Sean Bean). After Bond and Natalya (Izabella Scorupco) escaped from Trevelyan's clutches they found themselves being interrogated by Russian Defence Minister Mishkin (Tcheky Karyo), before chasing General Ourumov (Gottfried John) through the streets of St Petersburg in a tank.

The suit is made by Brioni, the bespoke menswear couture house that created the majority of the luxury suits worn by Brosnan in the role of James Bond. Brosnan was integral to the process of developing Bond's look, and was consulted on how his character would dress throughout his tenure. As costume designer Lindy Hemming later recounted: "We wanted him to look modern, but not trendy like someone in advertising. Pierce's own demands were that the designs had to reflect the lightness of modern man, but still be svelte and smooth."

The suit is made of blue wool with a silk-effect Brioni logo lining. The suit was made especially for Brosnan in the role, with the jacket labelled "Brioni, Roma" and featuring an Angels & Bermans costumiers label, which reads "1995 Goldeneye Pierce Brosnan". The waistcoat and trousers both feature a similar description within. A white shirt and tie have been added to complete the look of the costume, which is presented on a custom-made display featuring the film title and a description of the bespoke outfit. Dimensions (displayed): 38 cm x 60 cm x 182 cm (11" x 23 1/2" x 71 3/4")

Special shipping required; see special shipping notice in the Buyer's Guide.

Estimate. £10,000 - 15,000



222
 Xenia Onatopp's (Famke Janssen) Helicopter Costume M
James Bond: Goldeneye (1995)

Xenia Onatopp's (Famke Janssen) costume from Martin Campbell's Bond movie GoldenEye. Onatopp, the Soviet assassin who worked for renegade 00 agent Alec Trevelyan (Sean Bean), wore her costume during the final scenes of the film as she chased down Bond (Pierce Brosnan) in Cuba. She rappelled from a helicopter and fought Bond, who managed to reconnect her safety rope and shoot the helicopter down.

The costume consists of a nylon woven top with padded shoulders and chest; a pair of nylon trousers with plastic zips down the length of each leg; a black leather belt with a metal buckle and ring loops; and a black-and-purple safety harness with plastic clips and adjusters. Also included is a black-and-white still showing Onatopp in the film, a printed costume design and a page of printed storyboards depicting the character's death. The garments display minor wear from production use and age, and the lot is accompanied by a letter of authenticity from EON.

Estimate. £8,000 - 12,000

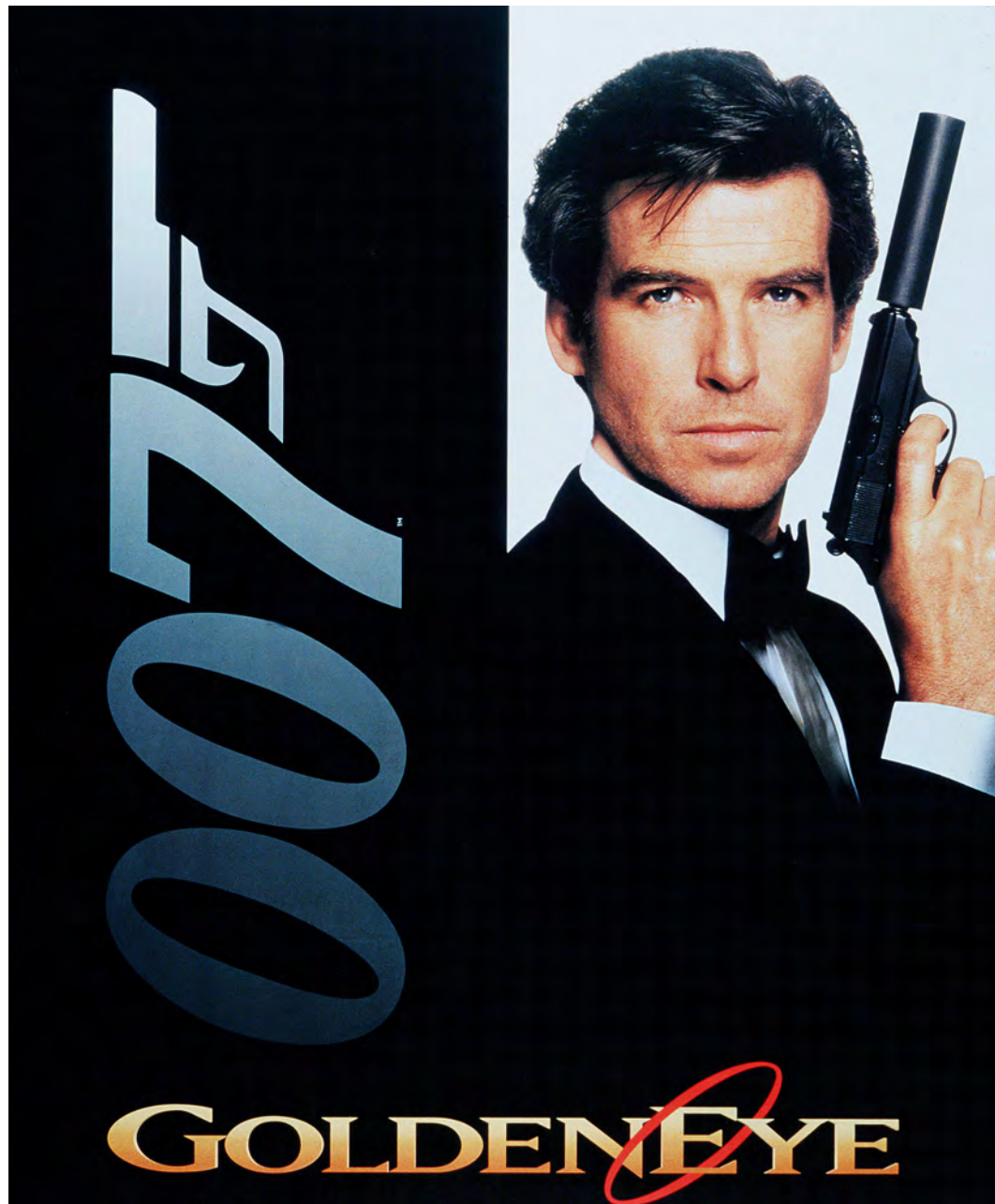

223

James Bond's (Pierce Brosnan) Hero
Walther PPK †
James Bond: Goldeneye (1995)

James Bond's (Pierce Brosnan) hero Walther PPK pistol and silencer from Martin Campbell's Bond movie GoldenEye. Bond used his Walther PPK throughout the film, from his infiltration of the Soviet chemical weapons facility (where the pistol was fitted with a silencer), to his meeting with Valentin Zukovsky (Robbie Coltrane). Colonel Ourumov (Gottfried John) later used Bond's weapon to kill Defence Minister Mishkin (Tcheky Karyo) and a guard, framing Bond for the crime.

The Walther PPK was Bond's weapon of choice throughout the series, up to and including Tomorrow Never Dies, when he then switched to the Walther P99. In *The Making of GoldenEye* by Garth Pearce, armorer Charlie Bodycomb explains that a real, blank-firing Walther PPK was used in close-up, because gun experts in the audience would be able to tell the difference.

The Walther PPK is made of blued steel with an acrylic grip, and has the serial number "811590". The silencer is attached to the pistol using a screw fitting via a threaded barrel. The pistol is sympathetically deactivated and features a functioning trigger, hammer, magazine release and safety. The lot is also accompanied by a certificate of authentication from Bapty, the production armourers, and the pistol's certificate of deactivation. Dimensions (pistol with silencer): 26.5 cm x 2.5 cm x 12 cm (10 1/2" x 1" x 4 3/4")

Firearm deactivated; see firearm deactivation notice in the Buyer's Guide.

Estimate. £30,000 - 50,000





224
James Bond's (Pierce Brosnan) Holster +
James Bond: Goldeneye (1995)

James Bond's (Pierce Brosnan) holster from Martin Campbell's Bond movie GoldenEye. Bond used holsters to carry his iconic Walther PPK pistol, and had two differently designed holsters in the film: a figure-hugging one to maintain the smooth line of his suit, and a larger Galco holster, which allowed Brosnan to draw the weapon quickly and stylishly. This is the Galco holster, and it features a moulded leather pocket, a leather loop which goes over the shoulder, and an elasticated strap which clips to the trouser band. The lot is also accompanied by a certificate of authentication from Bapty, the production armourers.

Estimate. £6,000 - 8,000



225
Peter Nelson Collection: 2nd Unit
Production Clapperboard M
James Bond: Goldeneye (1995)

A clapperboard from the production of Martin Campbell's Bond film GoldenEye. This clapperboard was used by the second unit, responsible for the action sequences.

The clapperboard is made of laser-engraved acrylic, and features the film's title, a section for the slate and take number, and "2nd Unit" in the bottom right corner. It bears the names of second unit director Ian Sharp and second unit cameraman Harvey Harrison, with the number "83" handwritten in the slate section and "3" handwritten in the take section, as well as the date "14.4.95" along the bottom.

Across the top of the plate is a wooden clapper that features a metal hinge, black-and-white stripes, and a magnet to give a sharper sound. Dimensions: 28 cm x 25 cm x 4.5 cm (11" x 9 3/4" x 1 3/4")

Estimate. £2,000 - 3,000



226
Peter Nelson Collection: Q's (Desmond Llewelyn) Suit M
James Bond: Goldeneye (1995)

Q's (Desmond Llewelyn) suit from Martin Campbell's Bond film Goldeneye. Q wore his suit when he showed James Bond (Pierce Brosnan) his new gadgets and car.

The three-piece suit is made from olive green tweed, with flecks of red, mustard and blue. It comprises a jacket, waistcoat and pair of trousers, with elasticated burgundy leather braces. Each piece features an Angels & Bermans costumier's label sewn to the interior, with "Mr D. Llewelyn, Jan 1995" handwritten in brown pen. The suit exhibits some wear from production use and age, including staining and pulled threads - predominantly to the jacket lining - and there is a small hole near the outer seam on the right trouser leg.

From the personal collection of Peter Nelson, previously displayed at his two museums, "The Cars of the Stars" and "The Bond Museum" in Keswick, Cumbria, until they closed in 2011.

Estimate. £4,000 - 6,000



227
Peter Nelson Collection: James Bond's (Pierce Brosnan)
Motorcycle Costume M
James Bond: Tomorrow Never Dies (1997)

James Bond's (Pierce Brosnan) motorcycle costume from Roger Spottiswoode's Bond movie Tomorrow Never Dies. Bond was wearing his costume when he and Wai Lin (Michelle Yeoh) were captured by Elliot Carver (Jonathan Pryce). The pair then escaped into Saigon on a motorbike, taking down a pursuing helicopter along the way.

The shirt is a blue linen Angelo Litrico (size "XL 43/44"). The black trousers feature an elasticated waistband, and an Angels & Bermans costumier's label is stitched into the back with "Mr Pierce Brosnan May -97" handwritten on it. The shoes are blue-and-white lace-up trainers.

From the personal collection of Peter Nelson, previously displayed at his two museums, "The Cars of the Stars" and "The Bond Museum" in Keswick, Cumbria, until they closed in 2011.

Estimate. £4,000 - 6,000

228
 Peter Nelson Collection: James Bond's
 (Pierce Brosnan) VR Gun M
James Bond: Die Another Day (2002)

James Bond's (Pierce Brosnan) VR gun from Lee Tamahori's Bond film Die Another Day. Bond used his gun during the simulation Q (John Cleese) prepared for him; upon exiting the simulation, he tossed it aside and looked at Q's other gadgets.

The gun is a Heckler and Koch MK23 BB pellet gun made of black-painted metal and plastic. It has been modified with two non-functioning laser pointers attached to either side of the barrel via pins and cyanoacrylate glue. Dimensions: 25 cm x 15 cm x 6 cm (10" x 6" x 2 1/2")

From the personal collection of Peter Nelson, previously displayed at his two museums, "The Cars of the Stars" and "The Bond Museum" in Keswick, Cumbria, until they closed in 2011.

Restricted ownership; see replica firearm notice in the Buyer's Guide.



Estimate. £4,000 - 6,000



229
 Peter Nelson Collection: SFX Aston Martin Traction
 Wheel M
James Bond: The Living Daylights (1987)

An SFX Aston Martin traction wheel from John Glen's Bond film The Living Daylights. James Bond (Timothy Dalton) and Kara (Maryam d'Abo) drove a weaponised Aston Martin V8 Vantage while fleeing Russia to Austria, with the KGB in hot pursuit. A total of 11 cars were used during filming, only three of which were drivable: an unmodified car, a stunt car and an SFX car.

This traction wheel is based on a Pirelli P Zero tyre and would have been used on one of the SFX cars. It comprises a black fibreglass tyre featuring a number of intentionally made small holes, and one side of the tyre is uncovered, revealing an accessible interior.

The interior includes a metal frame, retractable metal spikes and plastic tubing. These retractable spikes would have threaded through the tyre's holes when operated by air hydraulics via the plastic tubing. This can be seen on screen when Bond deploys the tyres after driving onto a frozen lake. The wheel exhibits some scuffs and paint wear from production use, and rusting to the metal from age. Dimensions: 68 cm x 68 cm x 25 cm (26" x 26" x 10")

From the personal collection of Peter Nelson, previously displayed at his two museums, "The Cars of the Stars" and "The Bond Museum" in Keswick, Cumbria, until they closed in 2011.

Estimate. £4,000 - 6,000

230
 Peter Nelson Collection: Bond (Pierce Brosnan) and
 Gustav Graves' (Toby Stephens) Fencing Sabre M
James Bond: Die Another Day (2002)

Bond (Pierce Brosnan) and Gustav Graves' (Toby Stephens) fencing sabre from Lee Tamahori's Bond film Die Another Day. Bond and Graves duelled with identical fencing sabres throughout the corridors of the Blades club after their fencing match escalated.

This fencing sabre includes a custom made aluminium blunted stunt blade which displays the numerous nicks and chips made during the sword fight. The hilt comprises a wire-wrapped, black and blue textured resin grip behind a sweeping steel handguard with an intricate cut-out design and a relief of the royal cypher "E II R". The item exhibits minor scuffs from production use. Dimensions: 95.5 cm x 11.5 cm x 13 cm (37 3/4" x 4 1/2" x 5 1/4")

From the personal collection of Peter Nelson, previously displayed at his two museums, "The Cars of the Stars" and "The Bond Museum" in Keswick, Cumbria, until they closed in 2011.

Estimate. £3,000 - 5,000



231
 \$500,000 Gaming Plaque M
James Bond: Casino Royale (2006)

A \$500,000 gaming plaque from Martin Campbell's Bond movie Casino Royale. James Bond (Daniel Craig), Le Chiffre (Mads Mikkelsen) and their fellow poker players used plaques during the high-stakes game at the Casino Royale in Montenegro.

The plaque is made of red pearlescent plastic and has a translucent green centre. "Casino Royale \$500,000 Montenegro" is printed on both sides in a gold-and-black font. Dimensions: 10.5 cm x 7.5 cm x 0.5 cm (4 1/4" x 3" x 1/4")

Estimate. £4,000 - 6,000



232
 \$1,000,000 Gaming Plaque M
James Bond: Casino Royale (2006)

A \$1,000,000 gaming plaque from Martin Campbell's Bond movie Casino Royale. James Bond (Daniel Craig), Le Chiffre (Mads Mikkelsen) and their fellow poker players used betting plaques during the high-stakes game at the Casino Royale in Montenegro.

The plaque is made of blue pearlescent plastic and has a translucent red-and-yellow centre. "Casino Royale \$1,000,000 Montenegro" is printed on both sides in a gold-and-black font. Dimensions: 11.5 cm x 8 cm x 0.5 cm (4 1/2" x 3 1/4" x 1/4")

Estimate. £4,000 - 6,000



233
 Felix Leiter's (Jeffrey Wright) Lucky Coin, Chips and
 Casino Royale Card Sets TΔ
James Bond: Casino Royale (2006)

Felix Leiter's (Jeffrey Wright) lucky coin, three poker chips and three card sets from Martin Campbell's Bond movie Casino Royale. Leiter played in the pivotal poker game with James Bond (Daniel Craig) and Le Chiffre (Mads Mikkelsen).

The lot comprises Felix's lucky half-dollar coin, which he kept on the table in front of him; \$25, \$100 and \$100,000 chips; the dealer indicator chip; 10 seat cards used for rehearsing the scene, numbered "1" to "10"; and two complete decks of cards. The coin is made of metal, the poker chips are resin, and the dealer's chip is acrylic. Each pack of cards is labelled in black marker pen - one reading "High Cards" and one "Game 3", indicating the specific scene they were used in. Dimensions (each card pack): 9 cm x 6.5 cm x 1 cm (3 1/2" x 2 1/4" x 1/2"); (each poker chip): 4 cm x 4 cm

Estimate. £2,000 - 3,000

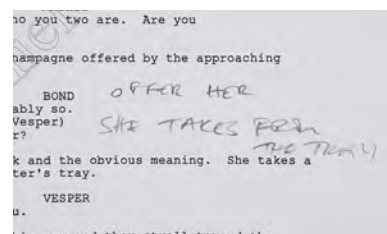
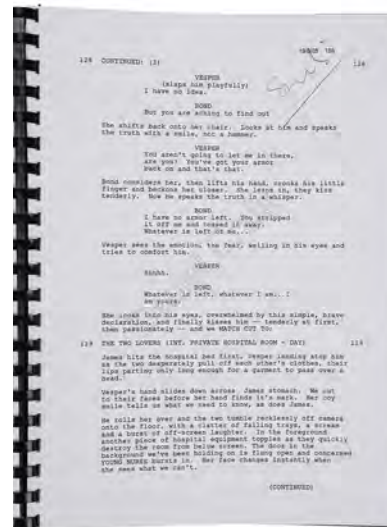
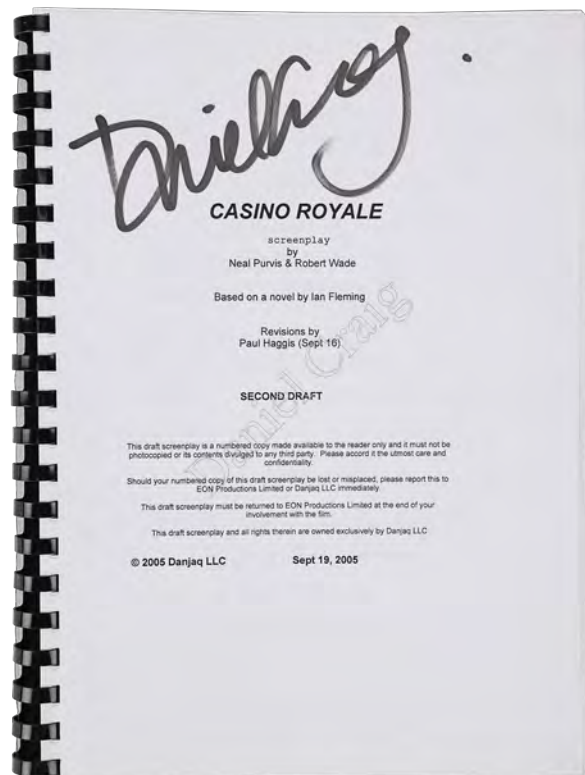

234
Daniel Craig's Annotated and Autographed Script Δ
James Bond: Casino Royale (2006)

Daniel Craig's autographed script from the production of Martin Campbell's Bond film Casino Royale. Craig autographed this second-draft script and donated it to raise funds for Anno's Africa in a charity auction.

Comprising 121 pages with handwritten annotations in pencil and Craig's name watermarked on each page, the script features the actor's autograph in black marker pen at the top of the front page. The script is spiral bound with a clear acetate cover that exhibits a few silver pen marks. Dimensions: 30 cm x 22.5 cm x 2.5 cm (11 3/4" x 8 3/4" x 1")

Estimate. £6,000 - 8,000

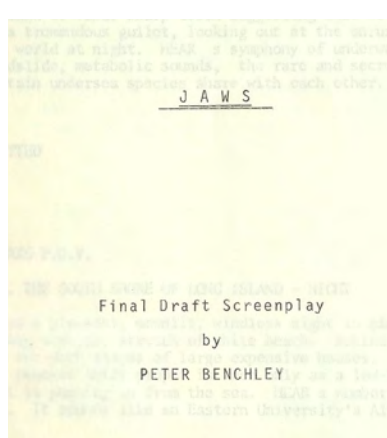
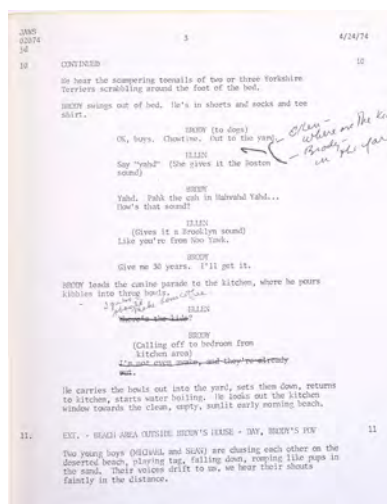
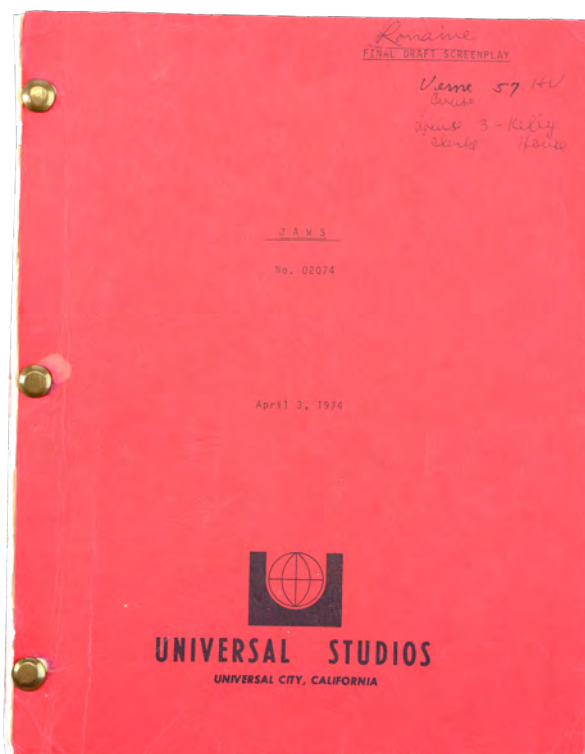

235
Lorraine Gary's Bound and Annotated Final Draft Screenplay Ω
Jaws (1975)

Lorraine Gary's bound and annotated final draft screenplay from Steven Spielberg's thriller Jaws. Gary portrayed Ellen Brody, the long-suffering wife of Amity Island's police chief (Roy Scheider).

Written by Peter Benchley, this brass brad-bound, hole-punched 113-page script is dated April 3, 1974 on its red Universal Studios cover. The cover is hand-marked for "Lorraine," hair stylist Verne Caruso, and women's costumer Louise Clark along with the name "Kelly House," the hotel on Martha's Vineyard where the cast and crew were housed during production. The screenplay features both handwritten pen and printed annotations throughout the margins, and comes with several page inserts bound to the interior with paperclips. It exhibits tearing, discolouration, loose pages, rolled edges, and creasing from production and age. Dimensions: 23 cm x 28 cm x 2.75 cm (9" x 11" x 1")

Estimate. £4,000 - 6,000

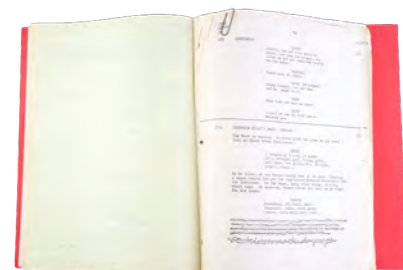

236
Two-Piece Jumanji Faceplate Ω
Jumanji (1995)

A two-piece Jumanji faceplate from Joe Johnston's family adventure Jumanji. Alan Parrish (Robin Williams), Sarah Whittle (Bonnie Hunt), Judy Shepherd (Kirsten Dunst), and Peter Shepherd (Bradley Pierce) played a mysterious but dangerous magic game called Jumanji which featured a two-piece faceplate.

This lot consists of one top and one bottom resin faceplate segments. Each segment features one half of the word "Jumanji" in front of a scenic background including volcanoes, Acacia trees, shrubbery, as well as characters from the game and film, including a monkey, a rhinoceros, an elephant, and big game hunter Van Pelt (Jonathan Hyde) on the corners. Both pieces are hand-painted red, green, and brown on top of a beige base and intentionally distressed by production to appear aged and worn. They exhibit glue residue on the back, worn and peeling paint, and some warping from age. Dimensions (each): 35.5 cm x 12.75 cm x 0.75 cm (14" x 5" x 0.25")

Estimate. £10,000 - 15,000

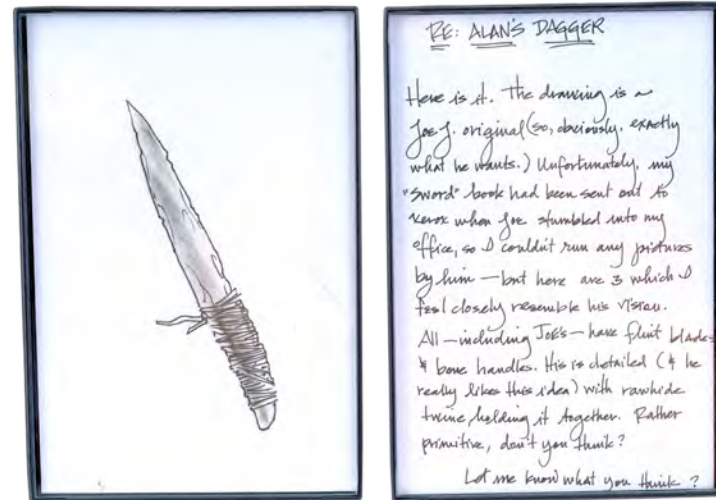

237
 Alan Parrish's (Robin Williams) Jumanji Dagger with Hand-Drawn Joe Johnston Concept Illustration Ω
Jumanji (1995)

Alan Parrish's (Robin Williams) Jumanji dagger with a concept illustration hand-drawn by Joe Johnston from Johnston's adventure film Jumanji. Alan wielded his makeshift knife against the lion he got to know inside Jumanji.

This lot consists of a resin knife wrapped with brown twine and textured and hand-painted to resemble a flint and bone handle and two high-quality printed copies of a concept illustration of the knife hand-drawn by Johnston and a note from a production crew member about the drawing, titled "RE: Alan's Dagger". The knife exhibits chipping and scuffing, and the frames exhibit adhesive residue. Dimensions (knife): 33.75 cm x 6.5 cm x 5.25 cm (13.25" x 2.5" x 2"); (frames): 10 cm x 15 cm x 1.5 cm (4" x 6" x 0.5")

Sold without copyright; see notice in Buyer's Guide.

Estimate. £4,000 - 6,000



238
 Jumanji Tokens and Dice Ω
Jumanji (1995)

Jumanji tokens and dice from Joe Johnston's family adventure film Jumanji. Alan Parrish (Robin Williams), Sarah Whittle (Bonnie Hunt), Judy Shepherd (Kirsten Dunst), and Peter Shepherd (Bradley Pierce) used the four animal tokens and dice to play the mysterious but dangerous magic board game Jumanji.

This lot consists of four resin game pieces: a rusted iron-colour elephant, a jade-colour monkey, an ivory-colour rhinoceros, and a black crocodile, all hand-painted to appear carved from natural materials. Also included are two beige dice with black pips. The set is intentionally distressed to appear aged and well-used with mild discolouration, chipping, and pitting throughout from production use. Dimensions (each): 10.25 cm x 10.25 cm x 5.25 cm (4" x 4" x 2")

Estimate. £8,000 - 12,000



239
 Cobra Kai Gi M
Karate Kid, The (1983)

A Cobra Kai gi from John Avildsen's martial arts drama The Karate Kid. The students of the Cobra Kai dojo wore gi during their training sessions with sensei John Kreese (Martin Kove). Several gi were seen when Daniel LaRusso (Ralph Macchio) first surveyed the Cobra Kai dojo, and when he later returned with Mr Miyagi (Pat Morita) to confront Kreese.

The gi includes a traditional white cotton jacket featuring a large grey Cobra Kai emblem on the back; a pleated lapel; double vents; and dual tie strings on each vent. Also included in the ensemble is a long black pleated cotton belt. The jacket features "Century" on its label and the Century logo is stitched on the belt. The gi has slightly yellowed with age and exhibits signs of use.

Estimate. £6,000 - 8,000



240
 No Lot

241
Prince Colwyn's (Ken Marshall) Hero Practical Glaive M
Krull (1983)

Prince Colwyn's (Ken Marshall) hero practical glaive from Peter Yates' fantasy adventure Krull. Colwyn retrieved the magical glaive so he could defeat the monstrous Beast.

The brass glaive is painted gold and decorated with faux gems and crystals on its front side. The back is undecorated and features a small latch that unlocks the blades hidden in each of the glaive's five points, allowing them to spring out using elastic bands. Each point features a piece of black tape and a small handwritten number, from 1 to 5. The glaive has some wear from age and use. Dimensions: 22.5 cm x 22.5 cm x 3 cm (8 ¾" x 8 ¾" x 1 ¼")

Contains mechanical components; see mechanical notice in the Buyer's Guide.

Estimate. £10,000 - 15,000



242
Leatherface's (R.A. Mihailoff) Autographed Mask M
Leatherface - The Texas Chainsaw Massacre III (1990)

Leatherface's (R.A. Mihailoff) mask from Jeff Burr's slasher sequel Leatherface: The Texas Chainsaw Massacre III. Leatherface wore his human-skin mask as he terrorised Michelle (Kate Hodge), Ryan (William Butler) and others with his chainsaw.

The mask is made of rubber latex and designed and painted to look like old leathery pieces of skin stitched together. The inside of the mask is autographed "To Nick" by Mihailoff and Kane Hodder, who was Leatherface's double and the film's stunt coordinator, as well as playing Jason Voorhees in four Friday the 13th films. The mask is pinned to a flock head and there is some tearing in places, most notably about the left temple and on the throat.

Estimate. £6,000 - 8,000

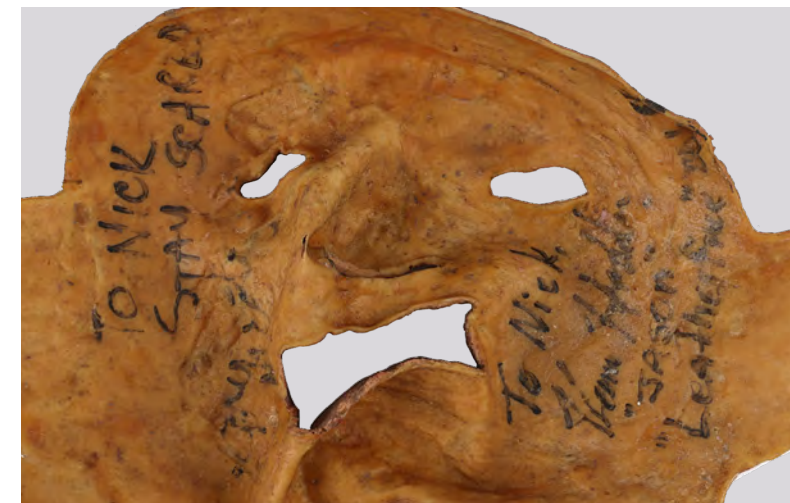



243
T. E. Lawrence's (Peter O'Toole) Hero Flare Gun m
Lawrence Of Arabia (1962)

T. E. Lawrence's (Peter O'Toole) hero flare gun from David Lean's historical epic Lawrence of Arabia. Lawrence used his flare gun to signal the start of an attack on a Turkish train, and Colonel Harry Brighton (Anthony Quayle) also used one.

The gun is a Webley & Scott No. 1 Mk. III with a flanged muzzle extension, which was a common signal pistol for British and Commonwealth forces during World Wars I and II. It is made predominantly of brass with a wooden grip. The flare gun has been sympathetically deactivated, but the trigger and hammer both still move. It is accompanied by an empty brass cartridge, a certificate of deactivation, and a letter of authenticity from John Richardson, son of special effects technician Cliff Richardson who worked on the film, detailing its history including its use on the set of Lawrence of Arabia. Dimensions: 24 cm x 4.5 cm x 14 cm (9 1/2" x 1 3/4" x 5 1/2")

Firearm deactivated; see firearm deactivation notice in the Buyer's Guide.

Estimate. £10,000 - 15,000



Everett Collection Inc / Alamy Stock Photo



ScreenProd / Photonostop / Alamy Stock Photo



244
 Mathilda's (Natalie Portman)
 Screen-matched Ruger SP101
 Revolver M
Léon: The Professional (1994)

Mathilda's (Natalie Portman) screen-matched Ruger SP101 revolver from Luc Besson's crime drama Léon: The Professional. Twelve-year-old Mathilda carried her revolver as her primary weapon while being taught to "clean" by Léon (Jean Reno). The revolver's serial number, as well as a small marking, matches it to the scene in the extended "International Cut" where Mathilda played Russian roulette. The weapon was also held by Portman in various promotional shots. It has been sympathetically deactivated, with the barrel and cylinder blocked.

The five-shot revolver was chosen by director Besson and principal armorer Christophe Maratier. It is accompanied by a letter of authenticity from Maratier, explaining the weapon's history, as well as two different certificates of deactivation (one in French, one in English). Dimensions: 19 cm x 3.5 cm x 12 cm (7 1/2" x 1 1/2" x 4 3/4")

Firearm deactivated; see firearm deactivation notice in the Buyer's Guide.

Estimate. £10,000 - 15,000



Moviestore/Shutterstock



245
 Leon's (Jean Reno) Screen-matched
 Compensated Two-Tone Beretta
 92FS M
Léon: The Professional (1994)

Leon's (Jean Reno) screen-matched compensated two-tone Beretta 92FS from Luc Besson's crime thriller Léon. Leon used his semi-automatic Beretta 92FS during the film's climax as he fought to protect Mathilda (Natalie Portman) from waves of policemen. It matches to the scene in which Leon has his gun pointed at an officer's head through the notable cut at the bottom of the right-side grip. It has been sympathetically deactivated, with the barrel blocked. The trigger, slide, and hammer all move, and the magazine can be ejected.

The pistol was chosen by director Besson and principal armorer Christophe Maratier. It is accompanied by a letter of authenticity from Maratier, explaining the weapon's history, as well as two different certificates of deactivation (one in French, one in English). It has some wear from production use, most notably paint wear along the barrel. Dimensions: 26 cm x 4 cm x 15 cm (10 1/4" x 1 1/2" x 6")

Firearm deactivated; see firearm deactivation notice in the Buyer's Guide.

Estimate. £10,000 - 15,000



Snap/Shutterstock

246
Léon's (Jean Reno) Sunglasses M
Léon: The Professional (1994)

Léon's (Jean Reno) sunglasses from Luc Besson's crime thriller Léon: The Professional. Léon wore his sunglasses at various points throughout the film, most notably in the opening scene and during Matilda's (Natalie Portman) training montage.

The sunglasses have smoke-grey lenses and a clear plastic frame encasing gold-toned metal stems running down the temples. This is one of several pairs of sunglasses made for the film, and feature the last five numbers from a worn-off inscription on the right inside temple, which once read "Junior Gaultier 58-0072". Dimensions (open): 15.5 cm x 15.5 cm x 4.5 cm (6" x 6" x 1 3/4")

Estimate. £6,000 - 8,000



247
Detective Roger Murtaugh's (Danny Glover) Smith & Wesson Revolver M
Lethal Weapon (1987)

Detective Roger Murtaugh's (Danny Glover) Smith & Wesson revolver from Richard Donner's buddy-cop action films Lethal Weapon and Lethal Weapon 2. Murtaugh carried his sidearm throughout Lethal Weapon as he and his partner Martin Riggs (Mel Gibson) investigated the mysterious death of a young woman. Murtaugh also used his pistol in Lethal Weapon 2 during his investigation of South African politicians smuggling gold and drugs into the USA, using his revolver to "revoke" Arjen Rudd's (Joss Ackland) diplomatic immunity at the climax of the movie.

This Smith & Wesson Model 19, chambered in a .357 Magnum calibre, features a four-inch barrel and wooden pistol grip. The black rubber grip used during the production was replaced with a wooden one after the films wrapped. It has been sympathetically and permanently deactivated, with a functioning cylinder, cylinder release, trigger and hammer. The barrel and cylinder have been blocked as part of the deactivation process.

There is some scuffing and scratching, most notably around the barrel, and some of the metal has become slightly tarnished. There are small chips in the wooden handle. Accompanying the lot is a copy of the rental agreement between Stembridge Gun Rentals, Inc and Warner Bros. and Lethal Weapon 2 Productions, as well as the weapon's deactivation certificate. Dimensions: 25.5 cm x 4 cm x 15 cm (10" x 1 1/2" x 6")

Firearm deactivated; see firearm deactivation notice in the Buyer's Guide.

Estimate. £4,000 - 6,000



248
Legolas' (Orlando Bloom) Lothlorian Arrow M
Lord Of The Rings: The Fellowship Of The Ring, The (2001)

Legolas' (Orlando Bloom) Lothlorian arrow from Peter Jackson's fantasy epic Lord of the Rings: The Fellowship of the Ring. Legolas was gifted a bow and quiver of arrows by the Lady Galadriel (Cate Blanchett) upon leaving Lothlorien, which he used throughout the rest of his adventures across Middle-earth.

The arrow has a wooden shaft, a yellow feather fletching secured by metallic thread wrapped around the shaft and a gold-tone arrowhead featuring an engraved swirl motif. This item was released by production to Sideshow Collectibles, a New Line Cinema licensee, as a reference piece for creating the company's line of replicas and figures. The shaft is engraved with the prop's details, the recipient and a reference code, the latter of which is also repeated on the arrowhead.

Dimensions: 97 cm x 4 cm x 5 cm (38 1/4" x 2" x 2")

Estimate. £6,000 - 8,000

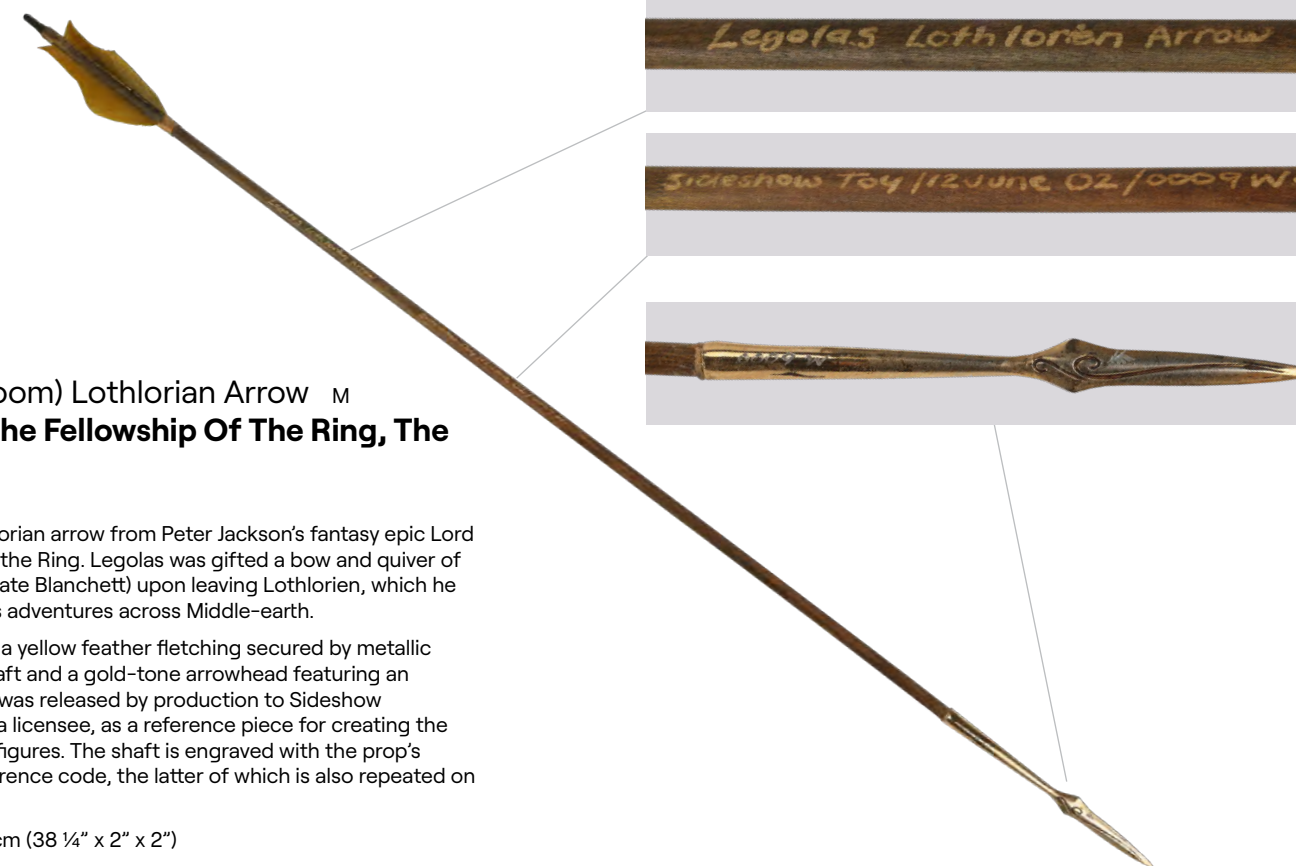

249
Orc Helmet M
Lord Of The Rings: The Return Of The King, The (2003)

An orc helmet from Peter Jackson's fantasy epic The Lord of the Rings: The Return of the King. Orcs wore all manner of mismatched armour throughout the trilogy, and this particular style can be seen worn by an orc manning a trebuchet during the Battle of Pelennor Fields.

Made from fibreglass and resin, the helmet is moulded to resemble several hammered plates of metal bolted together. It features a rubber nose hook and narrow, far-spaced eyeholes, as well as a leather chinstrap with a metal buckle. The helmet is painted dark grey, dry-brushed with a lighter grey, and has dark brown and green in its crevices to resemble rust and oxidation.

The helmet's interior features the number "53" obscured by a piece of masking tape, and a strip of brown tape on which "orc helmet" is handwritten in black ink. The item comes with a letter of authenticity from production company New Line Cinema. Dimensions: 37 cm x 18 cm x 18 cm (14 1/2" x 7" x 7")

Estimate. £4,000 - 6,000





Pictorial Press Ltd / Alamy Stock Photo



250
 Gandalf's (Ian McKellen) Sword Glamdring M
Lord Of The Rings: The Return Of The King, The (2003)

Gandalf's (Ian McKellen) sword Glamdring from Peter Jackson's fantasy epic The Lord of the Rings: The Return of the King. Made by the Elves of old, Glamdring was one of the wizard Gandalf's primary weapons, alongside his staff, which he carried with him throughout his mission to aid the Fellowship of the Ring. He notably wielded it during his battle with the Balrog, in which he used Glamdring to direct attacks of lightning, enabling him to defeat the demon. He also later used it in the Battle of the Black Gate.

This sword was produced by Weta Workshop and, during a visit to the set in 2002, was gifted to executives at Sideshow Toys, who were licenced to distribute collectables from the films. It features an aluminium blade and a silver-tone metal-plated urethane hilt with a high-quality blue latex grip. The hilt features an inscription of engraved Elven runes and a blue faux jewel. An engraving along the blade features the Weta logo and text that reads "Gandalf's Sword, Sideshow Toys / 12 June 02 / 0004W", with the latter reference number repeated on the hilt end. This lot is presented on a custom-made display featuring an image of Gandalf holding Glamdring. The lot exhibits minor nicks and chips to the blade edge. Dimensions (sword): 117 cm x 26 cm x 4 cm (46" x 10 1/4" x 1 1/2")

Estimate. £60,000 - 100,000

251
David's (Kiefer Sutherland) Wig, Earring, Coat and Trousers Display M
Lost Boys, The (1987)

David's (Kiefer Sutherland) wig, earring, coat and trousers from Joel Schumacher's 1987 comedy horror *The Lost Boys*. As the leader of the Lost Boys vampire gang, David wore his costume throughout the film while he prowled the town of Santa Carla.

This lot includes a blond mullet wig; a custom earring made from a strip of leather hanging from a twisted metal wire; a pair of black leather trousers (size 30); and a long black double-breasted trench coat. The coat has been customised with unique buttons (one of which is a watch face) and features a belt, a handwritten label in an interior pocket that reads "#1", and an 1870 "Republique Francaise" brooch attached by a safety pin. The coat has been modified for production with a harness hole in the upper back to allow the garment to be used during flying sequences.

These items come presented on a custom-made mannequin that includes a grey-painted plaster lifecast of Sutherland's head featuring a set of white fanged teeth. Also included is a spare black fabric belt and a metal clip in the shape of a wreath. This lot exhibits intentional staining and distressing to the leather trousers to appear aged and worn, with additional wear from production use. This includes dirt marks, unstitching of the back seam on the trousers, a missing button on the coat and make-up remnants on the wig's hairline mesh. Dimensions: 40 cm x 67 cm x 195 cm (15 3/4" x 26 1/2" x 76 3/4")

Estimate. £30,000 - 50,000



PictureLux / The Hollywood Archive / Alamy Stock Photo



colaimages / Alamy Stock Photo



Everett Collection Inc / Alamy Stock Photo

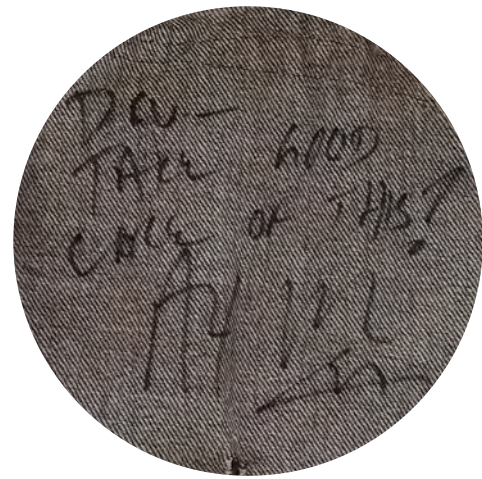

252
Marko's (Alex Winter) Autographed Stunt Jacket M
Lost Boys, The (1987)

Marko's (Alex Winter) autographed stunt jacket from Joel Schumacher's comedy horror The Lost Boys. As a member of the Lost Boys vampire gang, Marko wore his signature jacket throughout the film as he prowled the town of Santa Carla.

In addition to the hero jacket, costume designer Susan Becker made several stunt versions. This Levi's® denim jacket is a size 38 and has been customised with tapestries, patches and other accessories, including rubber fish lures. It has been intentionally frayed and distressed to look well worn. The glitter remnants and the intentionally made hole in the back of this jacket, indicate this is the stunt version used during the scene where Marko falls after being stabbed, and spurts his glittery blood over the Frog Brothers (Corey Feldman and Jamison Newlander). The jacket's interior features Winter's autograph, with a handwritten dedication that reads, "Dru, take good care of this!" The jacket exhibits loose threads and fading from production use and age.

Estimate. £12,000 - 18,000



253
Marko's (Alex Winter) Earring M
Lost Boys, The (1987)

Marko's (Alex Winter) earring from Joel Schumacher's 1987 dark comedy horror The Lost Boys. Marko wore his earring throughout the film. The metal earring is formed into a skull painted black with red eyes attached to the end of a short silver-tone metal chain. Dimensions: 4 cm x 1.5 cm x 1 cm (1 1/2" x 3/4" x 1/2")

Estimate. £1,500 - 2,500



254
Laddie's (Chance Michael Corbitt) Hero Fangs M
Lost Boys, The (1987)

Laddie's (Chance Michael Corbitt) hero fangs from Joel Schumacher's dark comedy horror The Lost Boys. Laddie, the half-vampire boy in the Lost Boys gang, showed his fangs in terror during the attack on the Emerson's home.

These resin fangs have been handpainted to imitate real teeth and gums. It features the actor's name "Chance" handwritten in pink pen on the inner gum. The teeth are glued to a beige cast mould of the actor's real teeth which displays "Chance Corbitt Uppers" handwritten on the base. The front right fang exhibits a chip from production use. Dimensions: 5.5 cm x 6.5 cm x 3 cm (2 1/4" x 2 1/2" x 1 1/4")

Estimate. £3,000 - 5,000



255
Max's (Edward Herman) Hero Top & Bottom Fangs and Case M
Lost Boys, The (1987)

Max's (Edward Herman) hero top & bottom fangs and case from Joel Schumacher's dark comedy horror The Lost Boys. Max revealed his fangs and head vampire identity during the film's finale.

This lot comprises two sets of handpainted resin top teeth fangs and one set of bottom fangs, each presented on white plaster cast moulds of Herman's real teeth. The two plaster moulds display "Ed Herman" handwritten on the top, and the bottom set features "Ed Db1" handwritten on the back of the fangs. Also included is a white plastic case with Herman's name hand-labelled on the lid. There are minor chips to the teeth on the moulds from production use. Dimensions (one upper): 5 cm x 5.5 cm x 4.5 cm (2" x 2 1/4" x 1 3/4")

Estimate. £3,000 - 5,000

2.13 m (7')



256
Robot Alien's (Brian Steele)
 Complete Costume us
Lost In Space (T.V. Series,
2018 - 2022)

Robot Alien's (Brian Steele) complete costume from Legendary Television's sci-fi series Lost in Space. The Robot first appeared in Season 1 as a multi-limbed alien robot, but transformed into a bipedal humanoid after scanning Will Robinson (Maxwell Jenkins), forming a bond with the boy and joining the Robinsons throughout the series.

Created by effects company Spectral Motion from original designs for the Robot from Irwin Allen's Lost in Space, this oversized and complete humanoid version of the Robot Alien's costume features both wearable and electronic components. The plated blue and silver-colour armour is constructed from fibreglass marked "Suit #1" and attached to a foam rubber bodysuit with snaps and plastic side-release buckles. Its helmet is constructed from foam rubber with plastic support, a domed plastic face, and a removable top which conceals an internal projector pre-programmed to project a video of non-coloured light. Also included are foam rubber top, bottom, shoes, and neck seal pieces.

This costume comes dressed on a custom-built soft body mannequin with the shoes, spats, helmet, neck seal, scales, armour, and arms all detachable. However, it is incapable of standing on its own, and will require a special stand for display. It exhibits scratching throughout the armour, applied grime, and dents in the foam rubber from production wear.

Contains electronics; see electronics notice in the Buyer's Guide.

Special shipping required; see notice in the Buyer's Guide.

Estimate. £30,000 - 50,000



257

**Judy Robinson's (Taylor Russell) Light-Up Spacesuit with Life Support System
with Life Support System Ω
Lost In Space (T.V. Series, 2018 - 2022)**

Judy Robinson's (Taylor Russell) light-up spacesuit with a life support system from Legendary Television's sci-fi series Lost in Space. Judy wore her spacesuit and its life support system packs throughout the series.

This lot consists of a domed plexiglas helmet with resin details painted silver-colour to appear metallic and marked "Judy B"; a futuristic blue, orange, and grey multi-fabric bodysuit jacket with matching trousers, gloves, a harness marked "Judy Stunt," and boot covers marked "Judy"; life support chest and back packs, both labelled "Judy Robinson," with magnetised closures and battery-powered electronics concealed in the back which operate lights in the chest and helmet and a fan embedded in the suit; a grey plastic and metal wrist communicator; and an additional battery and charger for the packs from production. The life support system, trousers, and boot covers exhibit scratching and flaking paint from production use.

Contains electronics; see electronics notice in the Buyer's Guide.

Estimate. £12,000 - 16,000



258

**John Robinson's (Toby Stephens) Light-Up Spacesuit with Life Support System
with Life Support System Ω
Lost In Space (T.V. Series, 2018 - 2022)**

John Robinson's (Toby Stephens) light-up spacesuit with a life support system from Legendary Television's sci-fi series Lost in Space. John wore his spacesuit and life support system packs throughout Season 1 after escaping from the Resolute with his family.

This lot consists of a domed plexiglas helmet with resin details painted silver-colour to appear metallic and marked "John B"; a futuristic blue, orange, and grey multi-fabric bodysuit jacket with matching trousers, gloves, and boot covers marked "John"; life support chest and back packs, both labelled "Tufeld" and marked "John B" with magnetised closures and battery-powered electronics concealed in the back which operate lights in the chest and helmet as well as a fan embedded in the suit; a grey plastic and metal wrist communicator; and an additional battery and charger for the packs from production. A stunt harness labelled "Stunt Maureen" is also included to complete the costume. The trousers and boot covers exhibit scratches and the harness is stained with grime from production.

Contains electronics; see electronics notice in the Buyer's Guide.

Estimate. £12,000 - 16,000



259

**Dr. Smith's (Parker Posey) Light-Up Spacesuit with Life Support System
Lost In Space (T.V. Series, 2018 - 2022)**

Dr. Smith's (Parker Posey) light-up spacesuit with a life support system from Legendary Television's sci-fi series Lost in Space. Dr. Smith wore her stolen spacesuit and its life support system packs throughout the series.

This lot consists of a domed plexiglas helmet with resin details painted silver-colour to appear metallic; a futuristic blue, orange, and grey multi-fabric bodysuit jacket labelled "Burns" on the chest with matching trousers and boot covers hand-marked "Smith 2nd Suit," "Tailored for P. Posey," "3 Smith," and "Smith Stunt" throughout the interiors; a life support backpack labelled "Burns" with a magnetised closure and battery-powered electronics which operate lights and a fan embedded in the suit; a matching life support chest piece; a grey plastic and metal wrist communicator; and an additional battery charger from production. While the lighting elements of the costume are functional, the helmet's light bars are dimmer than other comparable suits from this series. Full brightness could likely be restored by a lighting technician. The trousers and knee guards exhibit scratches from production, and there is slight warping to the plastic dome that prevents it from fitting tightly into the helmet.

Contains electronics; see electronics notice in the Buyer's Guide.

Estimate. £12,000 - 16,000



260

**Will Robinson's (Maxwell Jenkins) Spacesuit Components, Camcorder, Wrist Communicator, and Stunt Backpack
Lost In Space (T.V. Series, 2018 - 2022)**

Will Robinson's (Maxwell Jenkins) spacesuit components with a camcorder, wrist communicator, and stunt backpack from Legendary Television's sci-fi series Lost in Space. Will wore his spacesuit throughout Season 1, and later recorded his interactions with the Alien Robot.

This lot consists of a navy blue lycra and nylon blend jacket with orange detailing, an FBFX tag labelled "Maxwell Jenkins Will Robinson 'Lost in Space,'" and metal components; matching trousers, gloves, suspenders, and boot covers marked "Will Spacesuit S1," "4 Will", and "Too Small"; a nonfunctional futuristic orange and silver-colour camcorder; a grey plastic wrist communicator with elastic straps, and a matching foam stunt backpack. This lot is intentionally distressed with tears and burns at the knees, as well as scratching, cracks, and flaking throughout from production.

Contains electronics; see electronics notice in the Buyer's Guide.

Estimate. £4,000 - 6,000



261

**Marilyn Monroe's High Heeled Shoes
Marilyn Monroe**

A pair of Marilyn Monroe's high heels from the Eleanor "Bebe" Goddard Collection. Goddard was Monroe's foster sister and teenage friend.

This pair of black leather-and-suede high heels include ankle and foot straps embellished with small silver-toned studs. The shoes are accompanied by a black-and-white photocopy of a portrait of Monroe, a Heaven and Earth Certificate of Authenticity, a Cooper Owen purchase invoice, and a printed Letter of Authenticity from Goddard, in which she mentions that the pair were "one of Marilyn's favourites". This lot exhibits wear from age and usage, including peeling of the leather, rusting, and abrasions on the sole. Dimensions (each): 23 cm x 9 cm x 9.5 cm (9" x 3 1/2" x 3 3/4")

Estimate. £4,000 - 6,000



262

**Framed Pencil Drawing By Norma Jeane Baker (Marilyn Monroe)
Marilyn Monroe**

A framed pencil drawing by Norma Jeane Baker, before she became known as the cultural icon Marilyn Monroe. Rendered in pencil on brown paper, the drawing depicts the design for a housecoat, with an inscription along the top written by Norma Jeane's legal guardian Grace Goddard, reading "Marilyn drew this at the age of 12 years. Housecoat given to her for Xmas".

The item comes with a letter of authenticity written by Eleanor "Bebe" Goddard, foster sister and childhood friend of Baker, which explains its origin. The drawing is displayed in a wooden frame behind a pane of acrylic.

Dimensions (frame): 46.5 cm x 34.5 cm x 2 cm (18 1/2" x 13 1/2" x 3/4")

Estimate. £4,000 - 6,000





263
Marilyn Monroe's Earrings M
Marilyn Monroe

A pair of Marilyn Monroe's earrings from the Eleanor "Bebe" Goddard Collection. Goddard was Monroe's foster sister and teenage friend. Monroe gifted this bracelet and several other items to Goddard.

These clip-on drop earrings are teardrop-shaped and made from a number of circular-cut sparkly clear gems set in a silver-toned metal base. Each features a screw back which is used to adjust the fit on the earlobe. Accompanying the lot is a black-and-white photocopy of a portrait of Monroe and a printed Letter of Authenticity from Goddard. The gems exhibit some discolouration from age. Dimensions (each): 4.5 cm x 1.5 cm x 2 cm (1 3/4" x 1/2" x 3/4")

Estimate. £3,000 - 5,000

264
Marilyn Monroe's Bracelet M
Marilyn Monroe

Marilyn Monroe's bracelet from the Eleanor "Bebe" Goddard Collection. Goddard was Monroe's foster sister and teenage friend. Monroe gifted this bracelet and several other items to Goddard.

The bracelet comprises three rows of round-cut clear gems framed by a row of rectangular-cut clear gems on either edge. These sparkly gems are set in silver-toned metal casings, and the bracelet features a functional clasp and safety chain. It comes in a black jewellery box. Accompanying this item is a printed Letter of Authenticity from Goddard and a black-and-white photograph of Monroe printed on glossy photographic paper, which displays the number "G-71250" and "Asphalt Jungle" handwritten on the back. Minor tears are present along the left edge of the photograph. Dimensions: 19 cm x 3 cm x 1 cm (7 1/2" x 1 1/4" x 1/2")

Estimate. £3,000 - 5,000

265
Hand-signed Cheque for Sir Cecil Beaton M
Marilyn Monroe

A cheque for Sir Cecil Beaton signed by Marilyn Monroe. Beaton was a British photographer and Academy Award®-winning costume designer.

The cheque is for \$105.84 and dated "April 8 1958". Monroe's signature is in the bottom right corner, in blue ink. The cheque is displayed in a gold-coloured frame beneath an iconic image of Monroe in *The Seven Year Itch*. The display features a window in the back so the reverse of the cheque can be seen. The frame has some paint wear in two of the corners. Dimensions (display): 67.5 cm x 50 cm x 2 cm (26 1/2" x 19 3/4" x 3/4")

Estimate. £1,500 - 2,500



2.3 m (7.5')

266
Balloon Lady's (Angela Lansbury) Barrel Piano M
Mary Poppins Returns (2018)

Balloon Lady's (Angela Lansbury) barrel piano from Rob Marshall's musical fantasy sequel *Mary Poppins Returns*. Balloon Lady sat next to a barrel piano in a park fair while selling balloons that carried the Banks family, Jack (Lin-Manuel Miranda) and several others into the air.

The vintage barrel piano is mounted on a cart with spoked wooden wheels and dual wooden shafts, in between which is a lidded wooden storage box. The upper and midsections of the piano each have lids and there is a wooden barrel inside the midsection. The upper section contains strings, tuning pins and 59 hammers.

The piano also features two spool legs, two metal hand cranks - one on each side panel - and a metal handle on the left side panel. The piano is housed in dark brown wood panelling with several ornate glass windows. The panels and wood are decorated with gold-coloured patterns featuring a lobed leaf motif, some of which are engraved. The lot exhibits signs of wear commensurate with its age and would require repair in order to play music. Dimensions: 230 cm x 95 cm x 143.5 cm (90 1/2" x 37 1/2" x 56 1/2")

Special shipping required; see special shipping notice in the Buyer's Guide.

Contains mechanical components; see mechanical notice in the Buyer's Guide.

Estimate. £3,000 - 5,000



267
Mask of Loki [Ω](#)
Mask, The (1994)

The mask of Loki from Chuck Russell's fantasy comedy *The Mask*. Stanley Ipkiss (Jim Carrey) found a mysterious wooden mask floating in the city's filthy harbour, which later transformed him into a cartoonish figure called *The Mask*.

This green-and-brown-painted resin mask features cast woodgrain texturing and a riveted bar between the eyes, with Loki's emblem cast into the top. Dimensions: 21 cm x 17.5 cm x 10 cm (8 1/4" x 6 3/4" x 4")

Estimate. £10,000 - 15,000



268
Unfinished Mask of Loki and Wolf Whistle Maquette, Two Stanley Ipkiss (Jim Carrey) Busts and Mask of Loki Pin [Ω](#)
Mask, The (1994)

An unfinished mask of Loki and wolf whistle maquette, two Stanley Ipkiss (Jim Carrey) busts and a mask of Loki pin from the production of Chuck Russell's fantasy comedy *The Mask*.

The white resin mask and wolf whistle maquette remain unpainted. The maquette is a preliminary design for the Mask's transformation into a Tex Avery-style cartoon wolf while whistling at Tina Carlyle (Cameron Diaz) at the Coco Bongo nightclub. One of the biscuit-foam busts is an unpainted cast of Stanley's regular face, while the other depicts Stanley as his alter ego, *The Mask*, complete with a green-painted head. Both display "Jim Carrey" handwritten on their underside in black pen. Accompanying these is a small green resin Loki mask pin, created as a crew gift. The lot exhibits some dirt marks, minor scratches and scuffs from production use. Dimensions (larger bust): 25.5 cm x 29 cm x 39 cm (10" x 11 1/2" x 15 1/4")

Estimate. £2,000 - 3,000



269
Milo Maquette Crew Gift [Ω](#)
Mask, The (1994)

A Milo maquette crew gift from the production of Chuck Russell's fantasy comedy *The Mask*. New Line Cinema gifted the film's crew with maquettes of Stanley Ipkiss' (Jim Carrey) dog Milo after Milo donned the mask of Loki.

This painted resin maquette comes presented inside a clear acrylic case affixed to a black base, featuring a brass plaque on which "The Mask New Line Cinema" is engraved. A fracture runs across the bottom jaw of the maquette, which has been repaired, and the case exhibits minor scratches from handling. Dimensions: 25.5 cm x 15.5 cm x 21.5 cm (10" x 6 1/4" x 8 1/2")

Estimate. £2,000 - 3,000

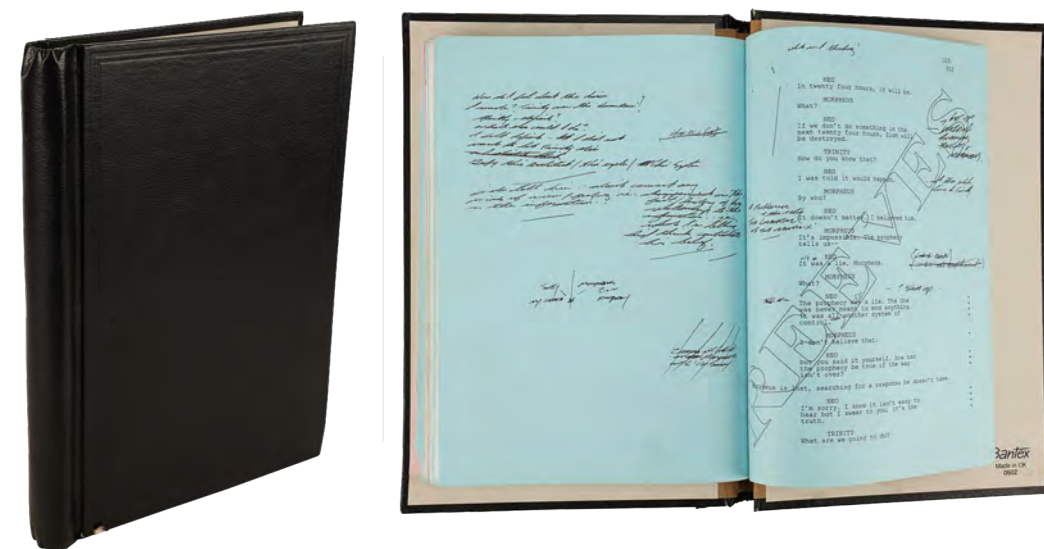

270
Keanu Reeves' Annotated Shooting Script
Matrix Reloaded, The (2003)

Keanu Reeves' annotated shooting script from the production of the Wachowskis' sci-fi sequel The Matrix Reloaded. This lot originated from a contact close to Reeves.

Presented in a black leather springback binder, the script's pink-coloured title page is dated "October 27, 2001" and displays a small list of coloured revisions with their corresponding dates. The document comprises 140 pages printed single-sided on blue, pink and white paper, with "Reeves" watermarked on every page. "Keanu Reeves" is printed along the top and bottom of the white-coloured pages. Many of the script's pages feature extensive annotations handwritten by Reeves in black ink. The leather binder's front cover exhibits minor damage. Dimensions: 32 cm x 23.5 cm x 2.5 cm (12 1/2" x 9 1/4" x 1")

Estimate. £8,000 - 12,000

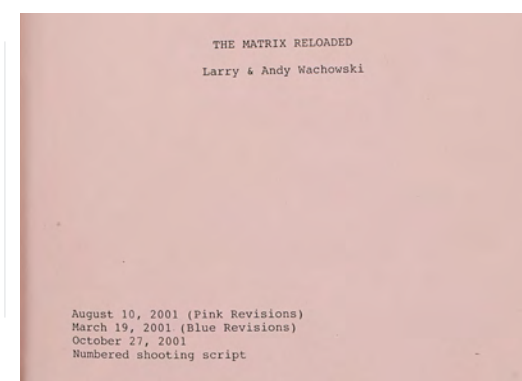
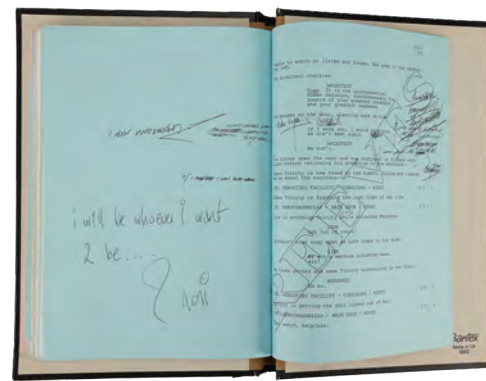
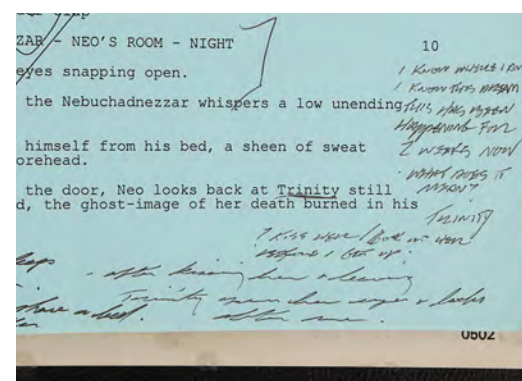

271
Agent K's Stunt Tri-Barrel Blaster
Men In Black II (2002)

Agent K's stunt tri-barrel blaster from Barry Sonnenfeld's sci-fi comedy-action sequel Men in Black II. Agent K (as played by Tommy Lee Jones) used his tri-barrel blaster, also known as the Arquillian Arm Cannon, to defeat the Klyothian known as Serleena (as played by Lara Flynn Boyle).

This blaster is made of cast urethane over a solid internal frame, painted black and silver-colour with a blue embellishment on the top, and features three distinctive barrels, a pistol grip, and an additional grip in the stock. It exhibits scuffing, cracking, and chipping in the paint throughout. Dimensions: 87.75 cm x 30.5 cm x 15.25 cm (34.5" x 12" x 6")

Estimate. £3,000 - 5,000



272
Young Agent K's Agency Suit Costume
Men In Black 3 (2012)

Young Agent K's agency suit costume from Barry Sonnenfeld's sci-fi comedy-action sequel Men in Black 3. Young Agent K (as played by Josh Brolin) wore his signature suit in 1969 while working for the top secret government agency known as the Men in Black.

This costume consists of a black, two-piece John David Ridge suit with tags in the jacket pocket and pants marked "Josh Brolin - Reg. Fit" and "New Alt Brolin Lifts" respectively, a matching black necktie, a white button-up long sleeve dress shirt with an Antio Distinctive Shirtmaker Beverly Hills tag with the initials "JB" and the date "March 2011," a black leather belt, and black leather dress shoes. Also included are two pink wardrobe tags with character, performer, and costume information. The shoes exhibit some signs of wear from production.

Estimate. £2,500 - 3,500



273
Boris the Animal's Costume
Men In Black 3 (2012)

Boris the Animal's costume from Barry Sonnenfeld's sci-fi comedy-action sequel Men in Black 3. Boris (as played by Jemaine Clement) wore his costume while working with his future self to kill the young Agent K (as played by Josh Brolin) in 1969.

This costume consists of a black bandana; a metal chain necklace with a resin talon; a light brown suede fringed jacket; a black shirt with a bumpy-textured silicone front and a zip-up elastane back with fastening strip straps; brown leather pants with black elastane braces and a John David Ridge tag marked for "Mr. Clement"; and boots with bumpy-textured black silicone coverings. Also included is a wardrobe tag with the name of the film, character, and performer. The jacket exhibits light staining and fringe bending; the silicone exhibits some wear.

Estimate. £2,500 - 3,500

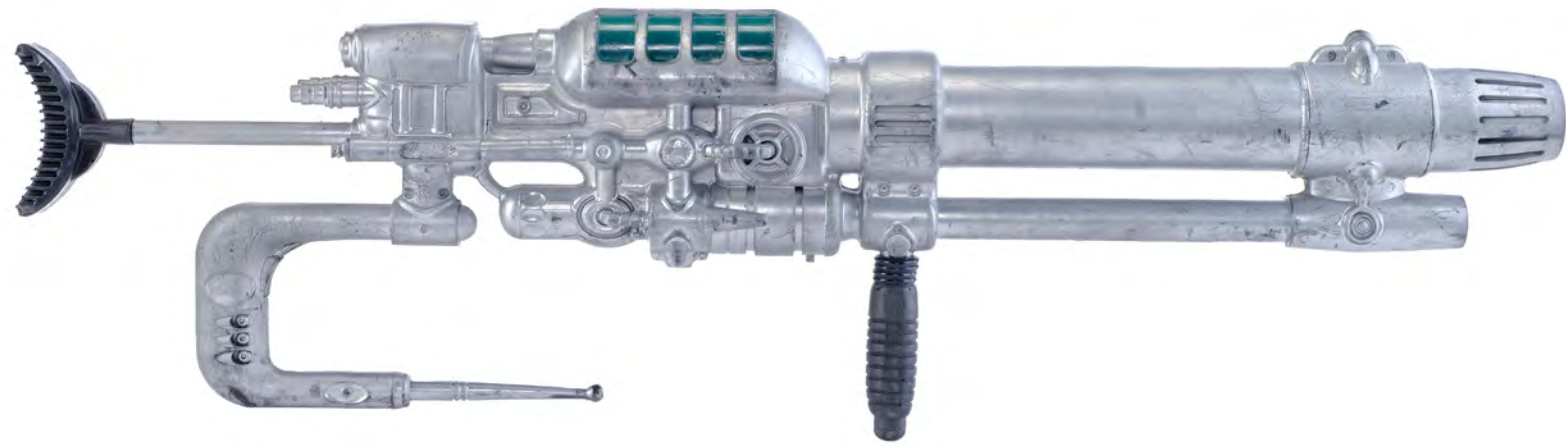

274
Agent J's Stunt Heavy Blaster Ω
Men In Black II (2002)

Agent J's stunt heavy blaster from Barry Sonnenfeld's sci-fi comedy-action sequel Men in Black II. Agent J (as played by Will Smith) used his heavy blaster to defeat the Klyothian known as Serleena (as played by Lara Flynn Boyle).

This blaster is made of cast urethane over a solid internal frame, painted black and silver-colour with a teal embellishment on the top, and features a large single barrel, a vertical forward grip, and a thin stock. It exhibits scuffing, cracking, and chipping in the paint throughout. Dimensions: 101.75 cm x 25.5 cm x 20.5 cm (40" x 10" x 8")

Estimate. £3,000 - 5,000

275
Hero Sonic Pistol Δ
Minority Report (2002)

A hero sonic pistol from Steven Spielberg's sci-fi thriller Minority Report. Agents chasing Chief John Anderton (Tom Cruise) through the car factory were armed with sonic weaponry, which incapacitated targets with a non-lethal sonic blast.

The pistol is predominantly made of machined aluminium, with a resin-and-faux-leather grip. The barrel is painted to look oxidised and well-used. The pistol has some scratches at the top of the grip. Dimensions: 22 cm x 5 cm x 15.5 cm (8 3/4" x 2" x 6")

Estimate. £4,000 - 6,000



276
Light-Up PreCrime Helmet Ω
Minority Report (2002)

A light-up PreCrime helmet display from Steven Spielberg's sci-fi action film Minority Report. PreCrime Unit members wore standard-issue helmets throughout the film while interacting with Chief John Anderton (Tom Cruise).

This lot consists of a helmet featuring a plastic cover plate and a clear plastic visor activated by a side button. A hidden switch illuminates blue LEDs in the visor powered by concealed 9V batteries. Included is a 20th Century Fox Certificate of Authenticity. The earpieces have been replaced, and the visor has undergone sympathetic restoration for reattachment. This lot exhibits notable glue marks, discolouration, and scuffing from production. Dimensions: 28 cm x 33.25 cm x 28 cm (11" x 13" x 11")

Contains electronics; see electronics notice in the Buyer's Guide.

Estimate. £5,000 - 7,000

277
Screen-matched Light-up Face Mask Printer M
Mission: Impossible - Fallout (2018)

A screen-matched light-up face mask printer from Christopher McQuarrie's action sequel Mission: Impossible - Fallout. Ethan Hunt (Tom Cruise) and August Walker (Henry Cavill) intended to use the printer on the man they thought was John Lark (Liang Yang), but Walker broke it while subduing the Lark decoy. The printer matches the one seen in the film through the damage pattern on its screen.

The printer is made primarily of resin and metal, with a cracked acrylic screen, and illuminates when a button hidden in the base is pressed. It is accompanied by two paper screen inserts and two pieces of caucasian skin-coloured latex, one of which features a face. Dimensions (closed printer): 29 cm x 33 cm x 4.5 cm (11 1/2" x 13" x 1 3/4")

Contains electronics; see electronics notice in the Buyer's Guide.

Estimate. £4,000 - 6,000

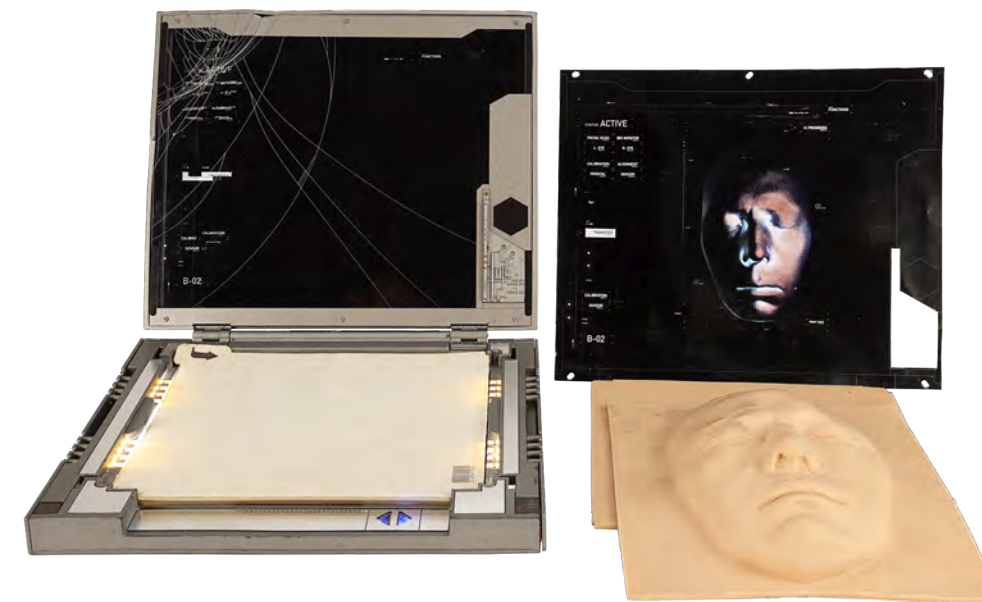



278
 Jim McConnell's (Gary Sinise) Spacesuit
Mission To Mars (2000)

Jim McConnell's (Gary Sinise) spacesuit from Brian De Palma's sci-fi thriller Mission to Mars. McConnell wore his spacesuit for much of the film, as he, Woody Blake (Tim Robbins), Terri Fisher (Connie Nielsen) and Phil Ohlmyer (Jerry O'Connell) went on a rescue mission to Mars.

The spacesuit consists of a helmet; a torso section with a built-in padded harness for a backpack (also included); a pair of trousers with sewn-in elasticated suspenders; and a pair of boots (labelled "McConnell #1"). The spacesuit features black strips around the arms and legs, which distinguished McConnell from the other astronauts. The spacesuit has been intentionally distressed to appear used on the surface of Mars, with staining, scuffing and scratches.

Special shipping required; see special shipping notice in the Buyer's Guide.

Estimate. £4,000 - 6,000



279
 Hero Practical Mechanical Hamunaptra Key
Mummy, The (1999)

A hero practical mechanical Hamunaptra key from Stephen Sommers' fantasy adventure The Mummy. Evelyn (Rachel Weisz) and Jonathan (John Hannah) Carnahan found the map to Hamunaptra in the key, before Evelyn used it to unlock the Book of the Dead.

The key is made of metal, painted and intentionally distressed to look like ancient bronze, and decorated with Egyptian hieroglyphs. It features a lid consisting of eight panels, which pop open through a spring loaded mechanism when the top half of the key is twisted. The paint is worn around the key's edges and corners. Dimensions: 8 cm x 8 cm x 4 cm (3 1/4" x 3 1/4" x 4")

Contains mechanical components; see mechanical notice in the Buyer's Guide.

Estimate. £20,000 - 30,000



280

Functional Hero Golden Book of the Living Mummy, The (1999)

A functional hero Golden Book of the Living from Stephen Sommers' action adventure *The Mummy*. The Golden Book of the Living was one of two prominent Ancient Egyptian artefacts to feature in the film, the other being the Book of the Dead. Also known as the Golden Book of Amun-Ra, it was discovered under a statue of Horus in Hamunaptra by Rick O'Connell (Brendan Fraser), Jonathan Carnahan (John Hannah) and Ardeth Bay (Oded Fehr), and was later used by Jonathan and Evelyn (Rachel Weisz) to make the nefarious Imhotep (Arnold Vosloo) mortal.

The heavy book is primarily made of resin finished in gold paint to resemble solid gold, and features several intentionally tarnished bronze components. Intricately decorated, the front cover features sporadic curved lines, an Egyptian hieroglyph insignia on the left side, and raised scarab beetle emblems. It also features a large moving, circular resin lock section, which is finished in shades of faux bronze and displays an embedded sun-shaped emblem, where a key would have been inserted.

The book's embellished metal spine displays 12 individual strands attached to each internal page. Designed to hold the front cover in place, four metal vulture-like clasps are inserted into the scarab emblems and are adjoined to uniquely designed hinges. Located within the book are 12 resin tablet pages covered in ornate hieroglyph detailing.

To open the book, the circular mechanical emblem on the cover must be twisted in an anticlockwise direction, which causes the two clasps on the right side to pop up. To close the book, the two clasps should be pushed down into their corresponding slots and held. The emblem should then be turned clockwise, causing the locks to fix back into place.

Intentionally distressed for the production, there are some small chips on the cover. Dimensions: 37 cm x 37 cm x 12 cm (14 1/2" x 14 1/2" x 4 3/4")

Contains mechanical components; see mechanical notice in the Buyer's Guide.

Estimate. £30,000 - 50,000





281
 Severen's (Bill Paxton) Screen-matched, Poster-matched and Autographed Distressed Leather Jacket M
Near Dark (1987)

Severen's (Bill Paxton) screen-matched, poster-matched and autographed distressed leather jacket from Kathryn Bigelow's neo-Western horror film *Near Dark*. Vampire Severen wore his leather jacket throughout the film. Through its holes and markings, this one screen-matches the climactic scene where Caleb (Adrian Pasdar) tried to run Severen down with a truck, before Severen climbed onto the engine hood and started pulling sections of the engine out. It also matches the film's posters, which feature Severen in his bloodied state.

The jacket features a San Diego Leather Jacket Factory label and is labelled size "40". It has been intentionally distressed with cuts and tears, and the left sleeve has been removed. After being hit by the truck, Severen's left arm was massively damaged, and there are holes where a damaged left sleeve would have been attached. The jacket is decorated with various patches and badges, and has been autographed in silver ink by Paxton and Lance Henriksen (Jesse), both of whom have added their character names below their signatures.

Estimate. £8,000 - 12,000

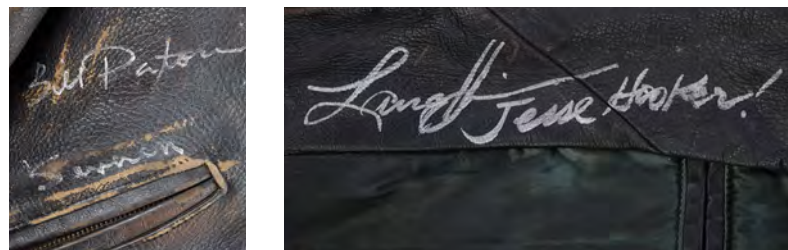

283
 Freddy Krueger's (Robert Englund) Hero Fedora M
A Nightmare On Elm Street 3: Dream Warriors (1987)

Freddy Krueger's (Robert Englund) hero fedora from Chuck Russell's horror sequel *A Nightmare on Elm Street 3: Dream Warriors*. Freddy wore his iconic fedora throughout the film as he terrorised the dreams of Nancy (Heather Langenkamp), Kristen (Patricia Arquette) and their friends.

The fedora is made of dyed brown beaver pelt. The lining was removed by costume designer Camile Schroeder to better fit Englund's head. The outside hatband was also removed. An "O" is handwritten inside the hat, distinguishing it as the hero hat. It is accompanied by a letter of authenticity from Schroeder.

Estimate. £15,000 - 25,000



Album / Alamy Stock Photo



282
 Stop-Motion Behemoth (Randy Crenshaw) Puppet Ω
Nightmare Before Christmas, The (1993)

A stop-motion Behemoth (Randy Crenshaw) puppet from Henry Selick's fantasy musical *The Nightmare Before Christmas*. Based on actor Thor Jorgensen and professional wrestler George "The Animal" Steele, Behemoth was a large man in overalls with an axe protruding from his head. He appeared throughout the film, most notably during the opening song, as he dragged Jack Skellington into the centre of town, and later when Lock, Shock and Barrel returned with the Easter Bunny and Behemoth excitedly proclaimed "Bunny!"

The puppet is made primarily of foam. Its original armature, which allowed it to be posed, was removed following production and replaced with an internal metal framework which allows it only to stand upright. It has a detachable replica resin axe, and stands on a cast resin display base with designs featuring the film's iconic swirling hills. The puppet's feet and lip have been sympathetically restored and the puppet has had minor paintwork touch up in places. Dimensions: 37 cm x 23 cm x 23 cm (14½" x 9" x 9")

Estimate. £6,000 - 8,000



284
 Will's (Ira Heiden) Wizard Master
 Cloak M
**A Nightmare On Elm Street 3:
 Dream Warriors (1987)**

Will's (Ira Heiden) wizard master cloak from Chuck Russell's horror sequel *A Nightmare on Elm Street 3: Dream Warriors*. In the dream world, Will donned his wizard master cloak and cast a spell to destroy the demonic wheelchair. The cloak was custom-made by costume designer Camile Schroeder and wardrobe supervisor Donna Schultz. It was the most expensive costume created for the film, and only one was produced.

Made from royal blue linen, the cloak includes sleeves; a red polyester lining; a high-standing purple collar with golden embellishments; a gold-toned jewelled metal clasp; and two cape layers made from grey hessian and purple-green-and-gold paisley-patterned corduroy. The cloak's blue fabric features stars and crescent moon shapes hand-painted in black with gold glitter.

The garment has been intentionally distressed with charred black marks and shredded, frayed edges. It also exhibits wear from production use and age, including discolouration, holes and loose thread, some of which has been replaced with two safety pins on the left shoulder. The lot is accompanied by a letter of authenticity from costume designer Schroeder and a photograph of Heiden wearing the cloak on set.

Estimate. £8,000 - 12,000



285
 Jennifer's (Penelope Sudrow) "Welcome to Prime Time"
 Head M
A Nightmare On Elm Street 3: Dream Warriors (1987)

Jennifer's (Penelope Sudrow) "Welcome to Prime Time" SFX head from Chuck Russell's horror sequel *A Nightmare on Elm Street 3: Dream Warriors*. Jennifer, who dreamed of becoming an actress, was one of the patients at Westin Hills Psychiatric Hospital who Freddy (Robert Englund) brutally murdered. In her dream, his arms and head sprouted from the wall-mounted television set and he lifted her up while shouting "Welcome to Prime Time bitch", before slamming her head into the TV.

The SFX head is made of cast resin and is hand-painted to match the actress' skin tone, with synthetic eyebrows and a blonde wig adhered with glue. The interior of the head is filled with foam, and features a hole where it had been fixed to the model body during production.

Accompanying the head is a behind-the-scenes photograph which shows Sudrow matching its facial expression while holding it next to her own. The head exhibits wear from production use, including three holes drilled into the base and a small crack on the left shoulder, while parts of the wig have unstuck. Dimensions: 29 cm x 32 cm x 30 cm (11 1/2" x 12 1/2" x 11 3/4")

Estimate. £4,000 - 6,000



286
 Freddy Krueger's (Robert Englund) Arm M
A Nightmare On Elm Street 5: The Dream Child (1989)

Freddy's (Robert Englund) arm from Stephen Hopkins' horror sequel *A Nightmare on Elm Street 5: The Dream Child*. In the dream world, Alice (Lisa Wilcox) used her dream master powers to throw Freddy into a pit of maniacs, who attacked him and tore off his arm.

The lot comprises a fibreglass forearm and a black foam bicep connected by a metal screw pole. The arm is dressed in a sleeve from Freddy's iconic red-and-green striped jumper, which has been intentionally distressed, with a large tear, small holes in the sleeve, and fake blood stains. The fibreglass arm also exhibits an area of damage to the top layer due to production use. Dimensions: 64 cm x 14 cm x 8 cm (25 1/4" x 5 1/2" x 3 1/4")

Estimate. £3,000 - 5,000



287
SFX Freddy Krueger (Robert Englund) Torso with Replica Freddy Child m
A Nightmare On Elm Street 5: The Dream Child (1989)

An SFX Freddy Krueger (Robert Englund) torso with a replica Freddy child from Stephen Hopkins' horror sequel A Nightmare on Elm Street 5: The Dream Child. During the film's climax, Jacob Johnson (Whit Hertford) used the power Freddy Krueger (Robert Englund) gave him to wrench Freddy's infant form from his adult body. This SFX torso was used for the effect of the baby being pulled out Freddy's back.

The torso is made primarily of foam covered in hand-painted, caucasian-skin-coloured foam latex and a ripped, oversized version of Freddy's iconic jumper. The torso is built around a wooden frame, and features Freddy's entrails, also made of hand-painted foam latex, along with a replica of the Freddy Krueger baby made from original production moulds. Dimensions: 53 cm x 78 cm x 93 cm (21" x 30 3/4" x 36 1/2")

Estimate. £8,000 - 12,000



288
Freddy Krueger's (Robert Englund) Screen-matched Mechanical Dentist Glove n
Freddy's Nightmares (T.V. Series, 1988 - 1990)

Freddy's (Robert Englund) screen-matched mechanical dentist glove from the horror anthology series Freddy's Nightmares. At the end of the pilot episode "No More Mr. Nice Guy", Freddy used his souped-up dentist glove to exact revenge on the police officer (Ian Patrick Williams) who killed him. The glove's seal lines, the imperfections of the metal, and the pattern of wear on each finger match this glove to the one seen on screen.

This lot comprises a brown leather glove featuring a hole in its palm; a metal armature covering the back of the hand and each finger; crude dentistry tools protruding from the fingertips; and the sleeve end of Freddy's iconic red-and-green jumper. The finger tools are wired to a battery-powered control box, with each wire and control switch numbered to a corresponding finger. Each tool remains fully functional and can be operated either individually or together.

The glove comes presented on a custom-made hand display and is accompanied by a letter of authenticity from the prop's creator Ryan Effner, where he states that this is "the one and ONLY glove of its kind." The lot exhibits minor scuffs and rust from production use. Dimensions: 27 cm x 24 cm x 47 cm (10 3/4" x 9 1/2" x 18 1/2")

Contains mechanical components; see mechanical notice in the Buyer's Guide.

Estimate. £6,000 - 8,000



289
Production-used Clapperboard M
Omen, The (1976)

A clapperboard from the production of Richard Donner's horror *The Omen*. The large black-painted wooden clapperboard features the film's title painted in white along the top, with the names of director Richard Donner and director of photography Gilbert Taylor below. Lines of white paint divide the clapperboard into two sections titled "Slate" and "Take". Both fields display written details, including "107" and "(1,2)", in black marker, which can only be seen in specific lighting. There are remnants of red chalk on the back of the clapperboard. The lot displays minor corrosion on the metal hinge of the clapper stick, which is quite loose. Dimensions: 3 cm x 39 cm x 30.5 cm (1 1/4" x 15 1/4" x 12")

Estimate. £6,000 - 8,000



290
Light-up Planetary Union
Comscanner M
Orville, The (T.V. Series, 2017 - Present)

A light-up Planetary Union comscanner from sci-fi comedy television series *The Orville*. Crew aboard the USS *Orville* carried comscanners, which acted as both a communicator and scanning device. The device illuminates when the right-side button is pressed and the scanner pops out. It is made primarily of resin and features a printed graphic on the front and the back features a barcode which has "Orville Yr1" above it. It features some minor damage to the graphic on the front. Dimensions (open): 18 cm x 7 cm x 2.5 cm (7" x 2 3/4" x 1")

Contains electronics; see electronics notice in the Buyer's Guide.

Estimate. £1,500 - 2,500



291
Light-up Planetary Union Plasma Shotgun M
Orville, The (T.V. Series, 2017 - Present)

A light-up Planetary Union plasma shotgun from sci-fi comedy TV series *The Orville*. Security personnel aboard the USS *Orville* carried PM-488 Titan shotguns, most notably when the Kylon attacked and boarded the *Orville* in Season 2.

The shotgun is made primarily of resin painted to resemble metal, and features two small buttons on the top, one of which illuminates a small torch on the barrel front, the other illuminating a panel at the top. The panel is magnetically attached to the weapon and can be removed, revealing the battery compartment. The bottom of the grip features a barcode sticker which has "Orville Yr1" printed above it. Dimensions: 54 cm x 6 cm x 18 cm (21 1/4" x 2 1/4" x 7")

Contains electronics; see electronics notice in the Buyer's Guide.

Estimate. £4,000 - 6,000



Warner Bros/Kobal/Shutterstock

292
The Preacher's (Clint Eastwood)
Hero Remington Revolver, Rig and
Spare Cylinder M
Pale Rider (1985)

The Preacher's (Clint Eastwood) hero Remington revolver, rig and spare cylinder from Eastwood's Western Pale Rider. The Preacher retrieved his weapons from a bank box and used them to protect a group of defenceless prospectors.

This Remington 1858 New Model Army revolver was one of six rented to the production by Stembidge Gun Rentals, to be used as The Preacher's primary firearm. It is made of steel with a wooden grip, and has been sympathetically deactivated. The hammer, trigger and cylinder all move. The revolver is accompanied by a leather rig, featuring a holster, spare bullets and a spare cylinder. The rig has "40" handwritten inside, with other faded handwriting. The spare cylinder is also deactivated. It should be noted that The Preacher changed out the cylinder on camera during the climactic gunfight, which is a rarity in film history.

The lot also includes two certificates of deactivation (one for the revolver, one for the spare cylinder), a photocopy of both certificates, and a copy of the original rental agreement, which shows the gun's serial number among those rented. Dimensions (revolver): 35 cm x 4 cm x 12.5 cm (13 3/4" x 1 1/2" x 5")

Firearm deactivated; see firearm deactivation notice in the Buyer's Guide.

Estimate. £40,000 - 60,000



Warner Bros/Kobal/Shutterstock



293
The Phantom's (Billy Zane) Costume
 Display M
Phantom, The (1996)

The Phantom's (Billy Zane) costume from Simon Wincer's superhero film *The Phantom*. The Phantom wore his costume throughout the film as he fought against injustice. Created by Lee Falk in 1936, *The Phantom* was the first superhero to wear a skintight costume, something which has become a hallmark of the superhero genre.

The costume was fabricated by Jim Henson's Creature Shop and comprises a neoprene rubber cowl with a suede lining for Zane's comfort; a black plastic eye mask; a long-sleeved top; a pair of trunks; leggings; a pair of black leather boots; and a leather belt and holster adorned with metal skull emblems. The top and leggings are made of an elasticated fabric, with a muscle print and a fine mesh layer, which is designed to be figure hugging.

The costume is displayed on a custom-built mannequin featuring a lifecast of Zane's face taken from a production-used cast, and has very minor wear from age and use, including some plucking to the fabric in small areas, and a small amount of repair to the nose bridge of the mask. Dimensions (display): 48 cm x 96 cm x 193 cm (19" x 37 3/4" x 76")

Special shipping required; see special shipping notice in the Buyer's Guide.

Estimate. £20,000 - 30,000

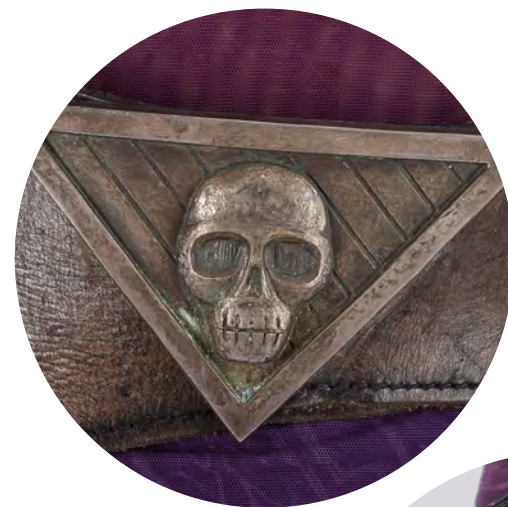

294
Angelica's (Penelope Cruz) Wig and Bandana +
Pirates Of The Caribbean: On Stranger Tides (2011)

Angelica's (Penelope Cruz) wig and bandana from Rob Marshall's action-adventure sequel *Pirates of the Caribbean: On Stranger Tides*. Angelica wore her wig and bandana when she disguised herself as Captain Jack Sparrow (Johnny Depp) to recruit pirates for an expedition.

This Louis Ferre synthetic wig comprises brown and black dreadlocks of varying lengths, with incorporated strings of beads and trinkets. These trinkets include a plastic reindeer shin bone, a piece of eight, and a long strand of resin beads featuring a Kuchi pendant.

The red cotton bandana has a blue printed floral design, and features a large braided plait laced with brown cord, which is located at the back and sits atop the bandana. The wig displays loose threads and stray hairs from handling, while there is minor fraying on the bandana.

Estimate. £4,000 - 6,000

295
Gorilla Soldier Costume Ω
Planet Of The Apes (1968)

A gorilla soldier costume from Franklin J. Schaffner's sci-fi classic *Planet of the Apes*. Astronaut George Taylor (Charlton Heston) encountered groups of super intelligent ape soldiers after he landed on a futuristic version of Earth.

This costume consists of a dark brown ribbed leather vest with snap buttons, a purple canvas shirt, and matching pants. It includes a brown and black leather and canvas shoulder sling with pouches, and leather boots, each of which have an ape-foot shaped toe box. The Western Costume tag in the vest displays the production number "2954-1," while the tags in the shirt and pants display the numbers "2954-2" and "2954-3" respectively. "WCC #53" is handwritten inside the shirt. The lot exhibits signs of wear from age and use, including scuffing in the leather and staining to the shirt and pants.

Estimate. £8,000 - 12,000



296
 George Taylor's (Charlton Heston) Prisoner Costume Ω
Planet Of The Apes (1968)

George Taylor's (Charlton Heston) prisoner costume from Franklin J. Schaffner's sci-fi classic Planet of the Apes. Taylor wore his ragged prisoner costume after being captured by the intelligent apes that dominated the planet.

This costume is made of brown cotton cloth with a fastening strip enclosure, intentional production-made distressing that includes staining and frayed edges, and a sewn-in 20th Century Fox wardrobe tag labelled "C. Heston." Also included are five photographs of Heston in costume. Dimensions (photographs, each): (23 cm x 28 cm) 11.5" x 9"

Estimate. £10,000 - 15,000



Allstar Picture Library Limited. / Alamy Stock Photo



297
 Ex-Presidents Reference Copy Masks M
Point Break (1991)

Four Ex-Presidents reference copy masks from the production of Kathryn Bigelow's action thriller Point Break. The gang of bank robbers known as the Ex-Presidents wore masks representing Ronald Reagan, Richard Nixon, Lyndon B. Johnson and Jimmy Carter, respectively.

These dense rubber masks were made from the original moulds as reference casts by Academy Award®-winning special effects group Amalgamated Dynamics, Inc. Each features hand-painted skin, hair and teeth, tape on the inside, and punctures at the back for display purposes. The masks exhibit small tears from age and come presented on black velour-coated polystyrene stands. Dimensions (each): 41 cm x 25 cm x 25 cm (16 1/4" x 10" x 10")

Estimate. £8,000 - 12,000



298
Full-Size Yellow Vector Cycle USA
Power Rangers Time Force (TV Series, 2001)

A full-size yellow vector cycle from the children's action series Power Rangers Time Force. Katie Walker (Deborah Estelle Phillips), the Yellow Time Force Ranger, and her teammates rode cycles to move quickly on the ground, a task not as well suited to their hover vehicles.

Built over a Suzuki RF900R, this yellow vector cycle features custom fibreglass body elements applied over the front and back axles and headlights, as well as gold-colour stripes and printed futuristic symbols on both sides. The cycle exhibits extensive signs of use throughout, including scratching, scuffing, chipped paint, and a missing windscreen. Its current functionality is unknown. Dimensions: 244 cm x 81.5 cm x 114.5 cm (96" x 32" x 45")

Special shipping required; see notice in the Buyer's Guide.

Contains electronics; see electronics notice in the Buyer's Guide.

Estimate. £6,000 - 8,000

299
Dutch's (Arnold Schwarzenegger) Screen-matched Costume Ω
Predator (1987)

Dutch's (Arnold Schwarzenegger) costume from John McTiernan's sci-fi action film Predator. Dutch wore his costume while trying to evade the deadly alien hunter in the Central American jungle.

The costume comprises a camouflage T-shirt; a pair of camouflage trousers; a leather vest; a pair of leather boots; and a leg holster. The trousers have "Arnold" handwritten in the waistband and screen-match those worn by Schwarzenegger during the guerilla camp assault sequence. They have some staining on the backside, and stage-blood stains on the front. The vest features multiple pockets and buckles, to which Dutch attached grenades. The boots are vintage replicas predominantly made of leather, with a green canvas collar and tongue.

Estimate. £6,000 - 8,000



300
Dastan's (Jake Gyllenhaal) Complete Costume and Swords Ω
Prince Of Persia: The Sands Of Time (2010)

Dastan's (Jake Gyllenhaal) complete costume and swords from Mike Newell's fantasy action film Prince of Persia: The Sands of Time. Prince Dastan wore his costume and wielded his twin swords throughout the film, as he attempted to clear his name after being framed for the murder of his father by his uncle Nizam (Ben Kingsley). He most notably wore his armoured chest piece during the assault upon the Holy City of Alamut.

The costume comprises a leather breastplate with ornate gold-toned metal and resin platings and two sword sheaths fastened to the back; a pair of brown corduroy trousers; a pair of black-and-brown leather-wrapped suede boots constructed around a pair of size 11 trainers; a red scarf; a brown leather gauntlet; a brown leather elbow gauntlet; three black leather belts; and two rubber swords. Accompanying this costume is a set of jewellery, including two metal bracelets (one of which features a skull); a braided leather bracelet; a metal chain necklace; and a leather cord necklace with four unique charms hanging from it. The lot is intentionally distressed, with applied scuffs and verdigris on the metal-plated details. It also exhibits further wear from production use, including two holes in the scarf and a missing clasp on the skull bracelet, which is now held together by a safety pin. Dimensions (larger sword): 79 cm x 14 cm x 4 cm (31" x 5 1/2" x 1 1/2")

Estimate. £20,000 - 30,000





301
Hero Flamethrower M
Prometheus (2012)

A hero flamethrower from Ridley Scott's sci-fi prequel Prometheus. The crew of the Prometheus landed on the distant moon LV-223 seeking evidence of an alien culture. To the surprise of the crew's scientists, mercenaries on board the ship brought flamethrowers to the seemingly dead planet. These weapons were used by Vickers (Charlize Theron) on the infected Holloway (Logan Marshall-Green), and by Janek (Idris Elba) on the mutated Fifield (Sean Harris).

This once-functioning flamethrower was custom-built for the film and features two gas tanks within an open metal frame. There is a black plastic trigger handle mounted at the rear of the flamethrower, with orange-coloured triggers. A carry handle juts out from the weapon, allowing the user to support it during use. The larger of the two tanks is decorated with a "Weyland Enterprises" logo sticker on each side of the canister. A plaque attached to the frame lists the makers of the lot, and gives the flamethrower's name as "Barbara". Decommissioned after use on the production, the flamethrower has small areas of rust. Dimensions: 95 cm x 22 cm x 38 cm (37 1/2" x 8 3/4" x 15")

Estimate. £7,000 - 10,000

302
Set of Four Ampule Vials M
Prometheus (2012)

A set of four ampule vials from Ridley Scott's sci-fi prequel Prometheus. Engineers used ampules to store vials of terraforming biochemicals, and David (Michael Fassbender) used a drop of a vial's contents to alter Holloway's (Logan Marshall-Green) DNA.

The hollow vials are made of translucent resin designed to mimic glass, and are accompanied by a faux-bone structure, which holds the vials in an ampule. Some of the vials show signs of repair, and several still contain a small amount of black liquid. Dimensions (each vial): 30 cm x 6.5 cm x 5 cm (11 3/4" x 2 1/2" x 2")

Estimate. £4,000 - 6,000



303
Brett's (Frank Whaley) Screen-matched, Quentin Tarantino Autographed Bullet-damaged Shirt M
Pulp Fiction (1994)

Brett's (Frank Whaley) screen-matched bullet-damaged shirt from Quentin Tarantino's crime film Pulp Fiction. Brett was shot multiple times in the front and back by hitmen Jules (Samuel L. Jackson) and Vincent (John Travolta), after they retrieved a black briefcase from his apartment for their boss Marsellus Wallace (Ving Rhames).

This shirt screen-matches the one seen on screen through the placement of the bullet holes. After filming, the shirt was laundered and autographed by Tarantino, with the stage blood replaced by red paint. The shirt was then presented as a gift to a production member, who retained it for over two decades.

The blue-green denim shirt is labelled size "L" and features Tarantino's autograph on the back in black pen, along with the inscription "Bang Bang". Apart from the intentional distress, the shirt also features some wear from production use. This includes areas of discoloration and a missing cuff button.

Estimate. £15,000 - 25,000





304
Honey Bunny's (Amanda Plummer) Hero Revolver M
Pulp Fiction (1994)

Honey Bunny's (Amanda Plummer) hero Smith & Wesson revolver from Quentin Tarantino's Oscar®-winning crime film Pulp Fiction. Honey Bunny wielded her firearm in both the opening and closing scenes when she and her lover Pumpkin (Tim Roth) attempted to rob a diner.

The revolver is a real deactivated hammerless Smith & Wesson 40 Centennial featuring a wooden grip, a unique safety grip, and a fixed trigger and cylinder. The weapon exhibits minor scuffs to the metal and scratches on the wooden grip from production use. Accompanying this lot is a letter of authenticity, a prop rental receipt and a deactivation certificate. Dimensions: 16 cm x 4 cm x 11 cm (6 ¼" x 1 ½" x 4 ¼")

Firearm deactivated; see firearm deactivation notice in the Buyer's Guide.

Estimate. £7,000 - 10,000



305
Big Kahuna Burger Bag M
Pulp Fiction (1994)

A Big Kahuna Burger bag from Quentin Tarantino's Oscar®-winning crime film Pulp Fiction. Big Kahuna Burger bags appeared in the scene where Jules Winnfield (Samuel L. Jackson) and Vincent Vega (John Travolta) visited Brett (Frank Whaley) at his apartment to collect a briefcase for their boss Marsellus Wallace (Ving Rhames). The fictional Big Kahuna Burger brand featured in many of Tarantino's films, including Reservoir Dogs, Four Rooms and Death Proof.

The bag is made of white paper, with the colourful Big Kahuna Burger logo printed on both sides. A black logo reading "Stone 12" is also printed on one side towards the top, with a recycling logo and serial number printed on the bottom. The bag displays creasing, discolouration and small tears from age and usage. Dimensions: 34.5 cm x 18 cm (13 ¾" x 7 ¼")

Estimate. £4,000 - 6,000



306
Collection of Red Apple Cigarette Packs, Tins and Pouches M
Quentin Tarantino: Various Productions

A comprehensive collection of Red Apple cigarette packs, tins and pouches from various Quentin Tarantino films. Red Apple cigarettes are a motif in Tarantino's films, with this collection featuring cigarettes from Pulp Fiction, Death Proof, Django Unchained, Inglourious Basterds and The Hateful Eight. The lot features a large box with six metal empty cigarette tins, plus a pouch filled with faux tobacco, from The Hateful Eight; A "U.S. Armed Forces Overseas" pack from Inglourious Basterds; a Red Apple Tans packet wrapped in plastic from Death Proof; a packet wrapped in plastic from Pulp Fiction; and a packet of Red Apple "Sweet and Mild" cigarettes from Django Unchained. The box has graphic designer Ross MacDonald's name handwritten inside. The Inglourious Basterds packet has been intentionally distressed to look well-worn and dirtied, and the Django Unchained packet is torn open at the top. Dimensions (box): 20.5 cm x 21.5 cm x 4.5 cm (8" x 8 1/2" x 1 3/4")

Estimate. £15,000 - 25,000

307
Frank Castle's (Thomas Jane) Bulletproof Vest Ω
Punisher, The (2004)

Frank Castle's (Thomas Jane) bulletproof vest from Jonathan Hensleigh's vigilante action film The Punisher. Castle's iconic vest saved him from several shots fired at him during his final assault against mafia boss Howard Saint (John Travolta). This black tactical vest is made of nylon with foam padding and silver-colour metal foil plating inside that is visible through the several large production-made holes throughout the chest with frayed edges. It has fastening strip side straps and a white skull emblem painted on the front. The vest's distressing, shoulder pad details, and skull stencil do not match those seen in the final cut of the film. The stencil does match that used on Frank's t-shirts. The vest is believed to be a prototype. The plating exhibits damage and discolouration from the use of squibs, and the shoulder is held together with black gaffer tape.

Estimate. £6,000 - 8,000



308
Rambo's (Sylvester Stallone) Stunt Machetes M
Rambo (2008)

An SFX stunt machete and a partially bladed hero stunt machete from Sylvester Stallone's action sequel Rambo. John Rambo (Stallone) forged a machete in a furnace and used it in several action sequences, including one where he decapitated an enemy soldier, and another where he impaled warlord Major Pa Tee Tint (Muang Muang Khin). A machete with a partial blade was used in the subsequent scene, in which Rambo disembowelled Tint. In an interview, Stallone said he chose a machete because he wanted Rambo "to forge a crude knife that is basically, him: nothing pretty, nothing glamorous." The SFX machete is made of rubber with a squared faux blade. The partially bladed machete is made of metal with tape along the edges of the blade for safety. The handles of both machetes are wrapped in black grip tape, and a small carrying strap is tied through a hole at the bottom of each handle. The SFX machete blade exhibits some flaking, and both machetes show some wear from production, but they remain in good overall condition.

Dimensions (SFX machete): 48 cm x 7 cm x 2 cm (19" x 2 3/4" x 3/4"); (partially bladed machete): 24 cm x 6 cm x 2 cm (9 1/2" x 2 1/2" x 3/4")

Estimate. £4,000 - 6,000

309
Dr. Carl Hill's (David Gale) Severed Head 
Re-Animator (1985)

Dr. Carl Hill's (David Gale) severed head from Stuart Gordon's horror comedy Re-Animator. To protect his work, Herbert West (Jeffrey Combs) beheaded Dr. Hill and re-animated him to take notes.

This specific head was featured in Fangoria issues 5 and 55, and auctioned off by the magazine from producer Brian Yuzna's personal collection for its "Get a Head" contest in 1986. Built from ornately detailed foam and latex, it features a large, exposed neck wound at the base with layers of fat, muscle tissue, bundled tendons, dangling nerves, and lifecast vertebrae all painted red to appear bloodied; bulging plastic eyes with clear outer domes painted blue; and a synthetic dark brown wig with hair hand-glued onto the sideburns. Gale wore a similar wig while filming as production could not match a wig to his natural hair colour.

Also included are two Letters of Authenticity from Fangoria editor Tony Timpone. The head is extensively applied with blood, some of which is flaking and crusty from age. It exhibits cracking in the foam and loose threads in the neck wound. Dimensions: 34.5 cm x 15.25 cm x 21.75 cm (13.5" x 6" x 8.5")

Estimate. £20,000 - 30,000



Re-Animated Prods/Empire/Kobal/Shutterstock

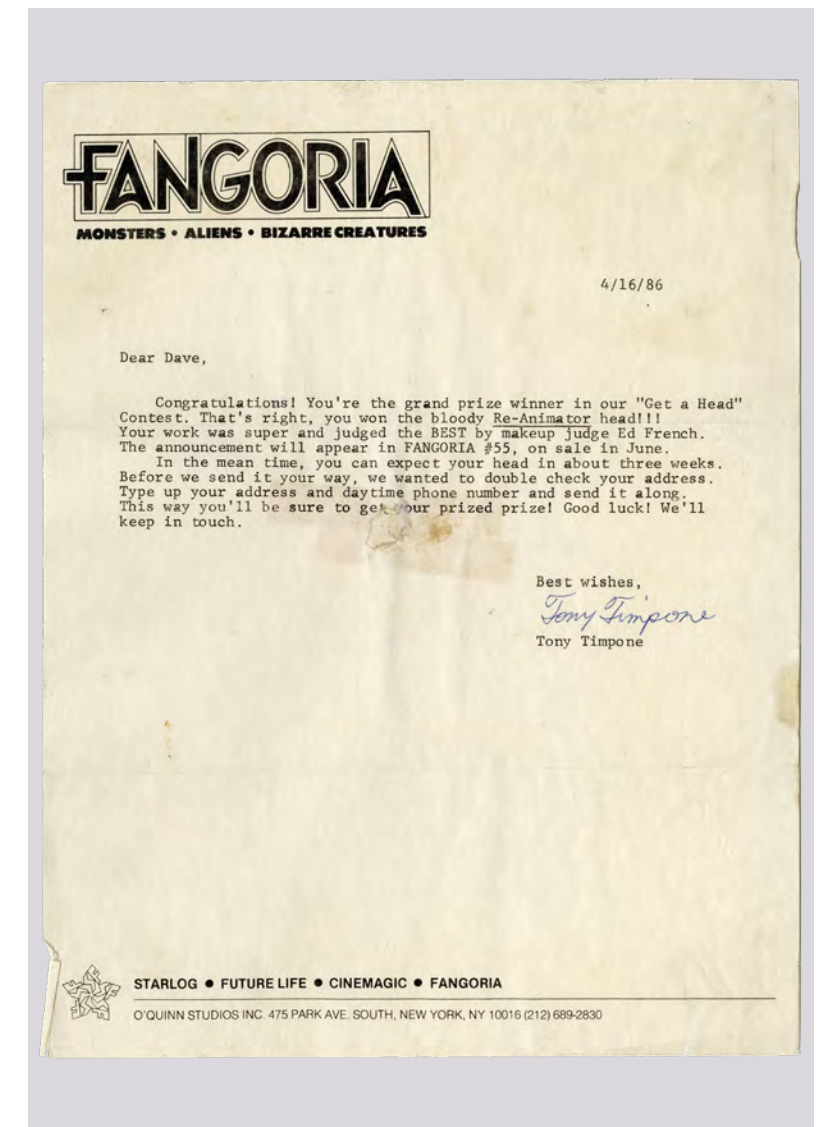



310
Nice Guy Eddie's (Chris Penn) Ring M
Reservoir Dogs (1992)

Nice Guy Eddie's (Chris Penn) ring from Quentin Tarantino's crime drama Reservoir Dogs. Eddie wore his ring throughout the film.

The ring is made of gold-plated metal with a faux diamond at the centre. Its shank is slightly warped and no longer perfectly circular, and there is some minor tarnishing within the shank. Dimensions: 1.5 cm x 3 cm x 2.5 cm (3/4" x 1 1/4" x 1")

Estimate. £3,000 - 5,000

311
RoboCop (Peter Weller/Robert John Burke) Helmet M
Robocop Trilogy (1987 - 1993)

A RoboCop (Peter Weller/Robert John Burke) helmet from the cult sci-fi action trilogy RoboCop. RoboCop wore his helmet as he fought crime on the streets of Detroit. It is not known which of the three RoboCop films this helmet is from, but it originates from the personal collection of the films' associate producer and visual effects artist Phil Tippett.

This fibreglass helmet is sprayed predominantly black, with several areas of blue-green paint. The inside of the helmet includes remnants of the previously attached jaw piece, paint and putty. "TS 2230" is handwritten on the interior, next to a sticker from Tippett Studio. The helmet is slightly warped and features scuffs and scratches throughout, with several cracks in the fibreglass, signs of repair and a few areas of silver-toned paint spattering. The lot includes a letter of authenticity from Phil Tippett. Dimensions: 32 cm x 20.5 cm x 20.5 cm (12 1/2" x 8" x 8")

Estimate. £8,000 - 12,000



312
Complete Replica
RoboCop Costume M
Robocop (1987)

A complete replica RoboCop costume inspired by Paul Verhoeven's sci-fi action film RoboCop. The costume was made by sculptor Bruce Hansing, using original production source material, and consists of a helmet; chest and back plates; under-armor; a neck cover, arm armour; gloves; leg armour; and feet.

Most of the pieces are made of fibreglass painted RoboCop's iconic metallic-blue. The under-armor is made of black vacuum-formed plastic, and the gloves and neck cover are made of black foam rubber. The separate pieces have plastic clips so they can be connected. The feet have water shoes glued inside for the wearer, and the helmet has foam padding for comfort. Some of the pieces have wear including scratches and scuffing.

Special shipping required; see special shipping notice in the Buyer's Guide.

Estimate. £8,000 - 12,000





313
Amber Mendez's (Maria Conchita Alonso) Adidas® Competition Jumpsuit and Boots M
Running Man, The (1987)

Amber Mendez's (Maria Conchita Alonso) Adidas® competition jumpsuit and boots from Paul Michael Glaser's dystopian action thriller The Running Man. Mendez wore a jumpsuit while a contestant on a deadly game show.

The costume consists of a yellow-and-silver one-piece spandex bodysuit with red trim; a stirrup strap on each leg; padded inlays on the arms; and diamond-patterned stitching on the shoulders and arms. The costume also features the name "MENDEZ" on the right of the chest; the words "RUNNING MAN" down the left leg; and the Adidas® logo on the outside of the right shoulder, the right shoulder padding, and the left hip.

Completing the ensemble is a pair of orange-and-red leather boots with the Adidas® logo on the upper quarter and the Adidas® name on the sole. There is an 11.5 cm tear in the heel counter of the right boot, while the shoelaces of the left boot are absent, and both boots exhibit fissures in the leather and general signs of wear.

Estimate. £6,000 - 8,000



314
"A" Camera Clapperboard Ω
Saving Private Ryan (1998)

An "A" camera clapperboard from the production of Steven Spielberg's war epic Saving Private Ryan. This clapperboard features an acrylic white slate with a black-and-white striped wooden clapper. It is engraved in red with the film's title, the names of director Steven Spielberg and associate cameraperson Janusz Kaminski, and fields titled "Scene," "Take," "A," and "NITE DAY INT EXT." It features a magnet on the right side, and exhibits scratches in the acrylic and black scuffing, chipping, and noticeable paint marks. Dimensions: 28 cm x 2.75 cm x 24.25 cm (11" x 1" x 9.5")

Estimate. £4,000 - 6,000



315
Ghostface Mask Ω
Scream 5 (2022)

A Ghostface mask from Matt Bettinelli-Olpin and Tyler Gillett's slasher sequel Scream. An unknown killer once again tormented and murdered the residents of Woodsboro while wearing a Ghostface mask.

The mask is made of rubber and has an attached black cotton hood. It comes with a letter of authenticity signed by R.J. Torbert, licencing director of Fun World, the company that originally developed the Ghostface mask for sale in novelty stores, and which licences the masks to the production. The mask is one of only two Fun World masks released with corresponding paperwork.

Estimate. £10,000 - 15,000



316
Ghostface Mask M
Scream: The T.V. Series (T.V. Series, 2015-2019)

A Ghostface mask from the slasher anthology series Scream: The TV Series. Ghostface wore his mask while committing horrific murders in the small town of Lakewood. Unlike the rubber masks seen in the Scream film franchise, this mask is made of vacuum-formed plastic with cast-in buckle detailing at the top and sides.

The mask is white with dark areas around the mouth and eyes. Black mesh covers the mouth, eyes and nose, and an elastic strap attaches it to the head. It has been intentionally distressed to appear well-used. Dimensions: 25.5 cm x 18.5 cm x 14 cm (10" x 7 1/4" x 5 1/2")

Estimate. £4,000 - 6,000

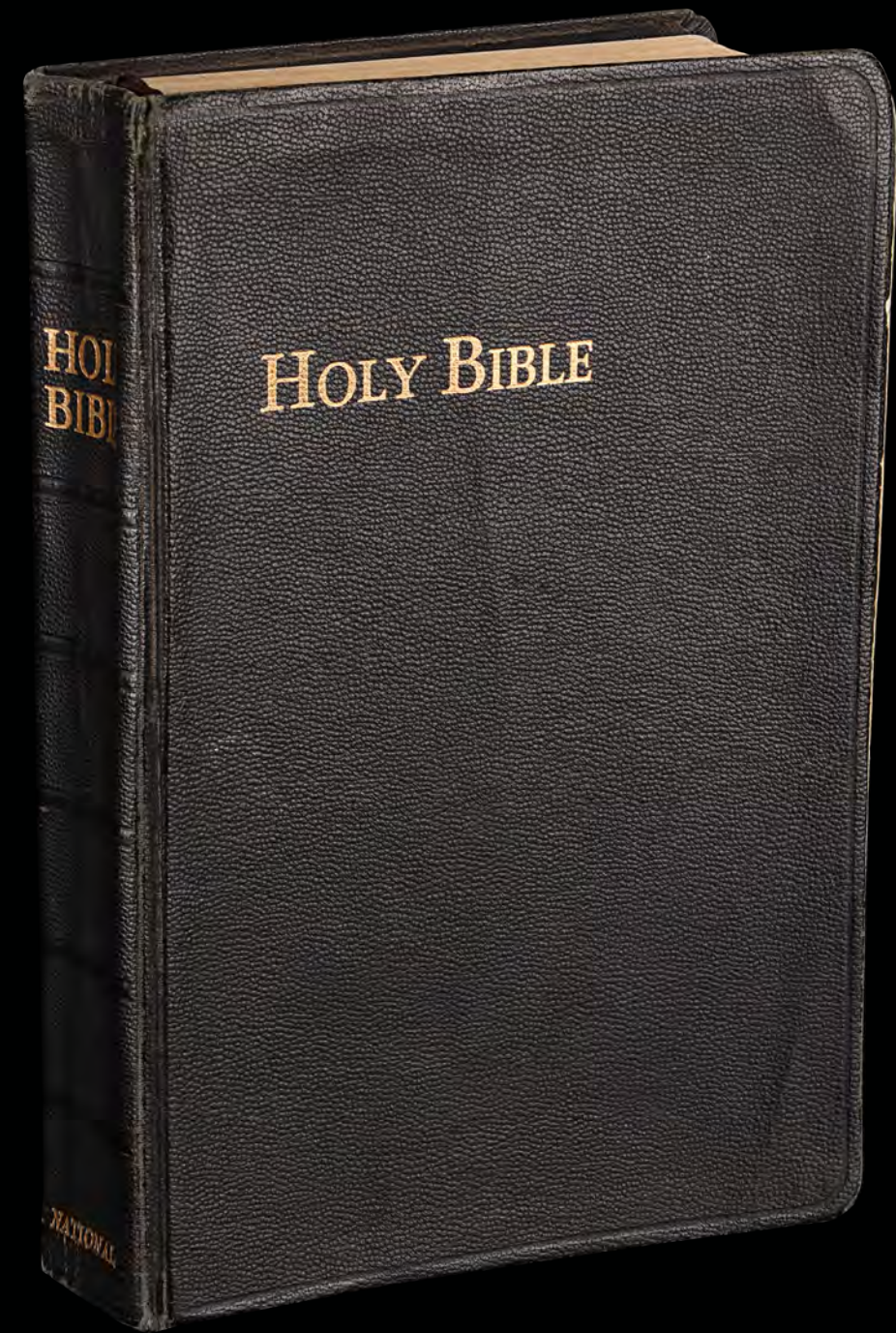

317
 Andy Dufresne's (Tim Robbins)
 Screen-matched
 Rockhammer Bible ^M
Shawshank Redemption, The (1994)

Andy Dufresne's (Tim Robbins) screen-matched rockhammer Bible from Frank Darabont's prison drama *The Shawshank Redemption*. Early in the film, Warden Norton (Bob Gunton) handed Dufresne the bible and told him that "Salvation lies within", a reference to the religious regime that operated at Shawshank. During the final payoff, the warden discovered that his secret and illegal bookkeeping accounts had been switched with the Bible during Andy's escape. In the front of the book, Robbins' character had penned "Dear Warden, you were right, salvation lay within". Turning the page to the very appropriate Exodus chapter, Norton then found the perfect outline of the tiny rock hammer Dufresne used to patiently tunnel his way out. Knowing he was cornered, the warden killed himself to avoid arrest and a lifetime in his own prison.

The leatherbound book screen-matches the one seen on screen in several ways, including markings and creases on the cover, Andy's handwriting on the inside cover, and creasing and minor tears on the first page of the hammer cutout.

Only one rockhammer Bible was finished for the pivotal scene, as the process of cutting the hammer outline was precise and time-consuming. Since production, the Bible has undergone some minor, careful and sympathetic restoration, most notably at the base of the hammer cut-out and inside the cover. Dimensions: 24.5 cm x 17 cm x 5 cm (9 3/4" x 6 3/4" x 2")

Estimate. £100,000 - 150,000



Snap/Shutterstock



The Holy Bible

Containing the OLD AND NEW TESTAMENTS

Translated out of the Original Tongues and with the Former Translations diligently compared

AUTHORIZED (KING JAMES) VERSION
Self-Pronouncing Reference Edition



THE NATIONAL BIBLE PRESS • PHILADELPHIA
PRINTED IN U. S. A.

Dear Warden,
You were right,
Salvation lay within
Andy Dupresne

THE SECOND BOOK OF MOSES CALLED EXODUS*

CHAPTER 1
The Oppression of the Children of Israel

1 **N**OW these are the names of the children of Israel, which came into Egypt; every man and his household came: 2 Reuben, Simeon, Levi, and Judah, 3 Is'sa-char, Zeb'u-lun, and Benjamin, 4 Dan, and Nap'h'ta-li, Gad, and Asher. 5 And all the souls that came out of the loins of Jacob were seventy souls: for Joseph was in Egypt already. 6 And Joseph died, and all his brethren, and all that generation. 7 And the children of Israel were fruitful, and increased abundantly, and multiplied, and waxed exceeding mighty; and the land was filled with them. 8 Now there arose up a new king over Egypt, which knew not Joseph. 9 And he said unto his people, Behold, the people of the children of Israel are more and mightier than we: 10 Come on, let us deal wisely with them; lest they multiply, and it come to pass, that when there falleth out any war, they join also unto our enemies, and fight against us, and so get them up out of the land.

11 Therefore they did set over them taskmasters to afflict them with their burdens. And they built for Pharaoh treasure cities Pi'thom and Ra'am'ses. 12 But the more they afflicted them, the more they multiplied and grew. And they were grieved because of the children of Israel. 13 And the Egyptians made the children of Israel to serve with rigour: 14 And they made their bitter with hard bondage, in mortar, and in brick, and in manner of service in the field: all their service, wherein they made them serve, was with rigour. 15 And the king of Egypt said unto the Hebrew midwives, which the name of the one was Shiph'rah, and the name of the other Pu'ah: 16 And he said, When ye do office of a midwife to the Hebrew women, and see them upon their stools; if it be a son, then shall kill him: but if it be a daughter, then she shall live. 17 But the midwives feared God, and did not as the king of Egypt commanded them, but saved the men children alive. 18 And the king of Egypt called for the midwives, and said unto them, Why have ye done thus thing, and have saved the children alive? 19 And the midwives said unto Pharaoh, Because the Hebrew women are strong, and the oppression of Israel is hence. 20 So Joseph died, being hundred and ten years old: and they embalmed him, and he was put in a coffin in Egypt.

CHAPTER 2
The Birth and Youth of Moses

1 **A**ND there went a man of the house of Levi, and wife a daughter of Levi. 2 And the woman conceived, and bare a son: and when she saw him that he was a goodly child, she hid him three months. 3 And when she could no longer hide him, she took him an ark of bulrushes, and daubed it with slime and pitch, and put the child therein; and she laid it in the flags by the river's brink. 4 And his sister stood by him to wit what would be done to him. 5 And the daughter of Pharaoh came down to wash herself at the river; and her maid walked along by the river, and when she saw the ark among the flags, she sent her maid to fetch it. 6 And when she had opened the ark, she saw the child: and, behold, the babe wept. And she had compassion on him, saying, This is one of the Hebrews' children. 7 Then said his sister to Pharaoh's daughter, Shall I take a nurse for the child? Shall I go and call to thee a nurse of the Hebrew women, that she may nurse the child for thee? 8 And Pharaoh's daughter said to her, Go. And she called the child's name Moses. 9 And she called the child's name Moses, saying, Because I drew him out of the water. 10 And the child grew, and she brought him unto Pharaoh's daughter, and he became her son. And she called his name Moses: and she said, Because I drew him out of the water. 11 And it came to pass in those days, when Moses was grown, that he went out unto his brethren, and looked on their burdens: and he spied an Egyptian smiting an Hebrew, one of his brethren. 12 And he looked this way and that way, and when he saw that there was no man, he slew the Egyptian, and hid him in the sand. 13 And when he went out the second day, behold, two men of the Hebrews strove together: and he said to him that did the wrong, Wherefore smitest thou thy fellow? 14 And he said, Who made thee a prince and a judge over us? intendest thou to kill me, as thou killedst the Egyptian? And Moses feared, and said, Surely this thing is known. 15 Now when Pharaoh heard this thing, he sought to slay Moses. But Moses fled from the face of Pharaoh, and dwelt in the land of Mid'i-an: and he sat down by a well. 16 Now the priest of Mid'i-an had seven daughters: and they came and drew water, and filled the troughs to water their father's flock. 17 And the shepherds came and drove them away: but Moses stood up and helped them, and watered their flock. 18 And when they came to

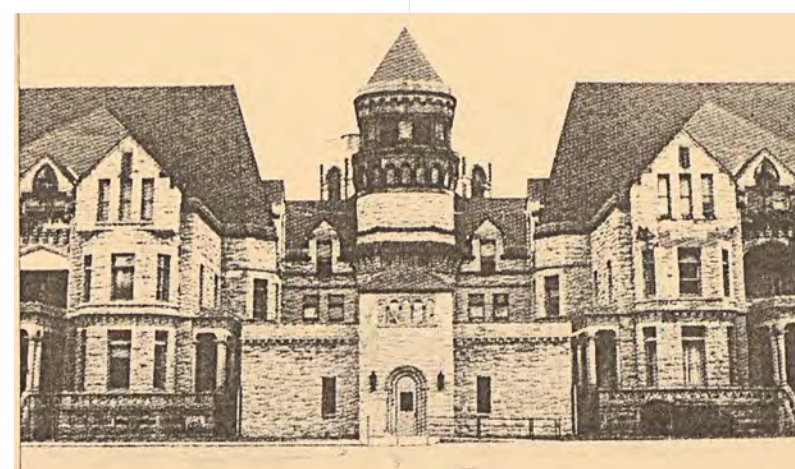
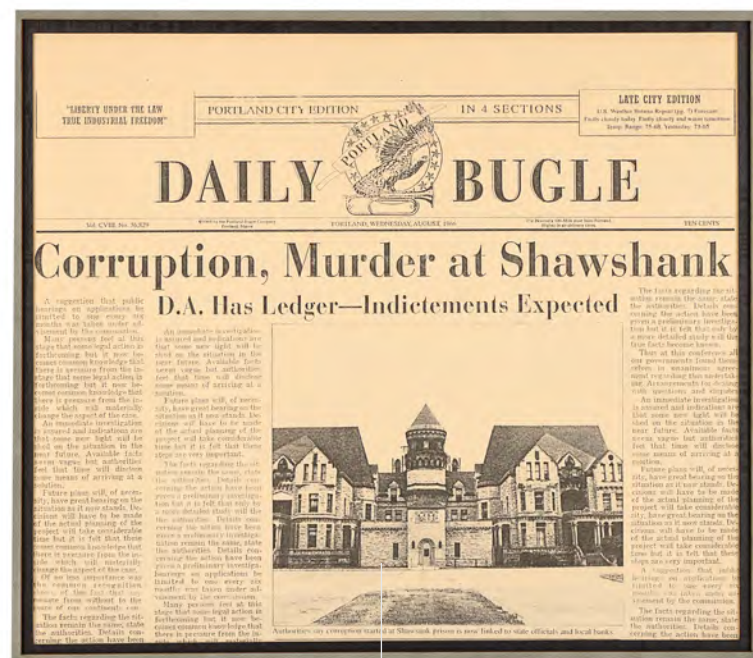

318
"Corruption, Murder at Shawshank" Newspaper 
Shawshank Redemption, The (1994)

A newspaper from Frank Darabont's prison drama The Shawshank Redemption. A copy of the Portland Daily Bugle was seen on the desk of Shawshank Warden Samuel Norton (Bob Gunton) after Andy Dufresne's (Tim Robbins) escape from the prison.

The newspaper bears the headline "Corruption, Murder at Shawshank," with a subheading that reads, "D.A. Has Ledger - Indictements [sic] Expected" above an image of the prison. The newspaper is folded and features printed copy on its front page, centre spread and back page. It has a beige hue due to oxidation, commensurate with its age.

Dimensions: 34 cm x 32 cm x 0.5 cm (13 1/2" x 12 1/2" x 1/4")

Estimate. £8,000 - 12,000



319
Shawshank Prison Inmate Uniform 
Shawshank Redemption, The (1994)

A Shawshank prison inmate uniform from Frank Darabont's prison drama The Shawshank Redemption. All the prisoners at Shawshank State Prison wore the same uniforms.

This costume consists of a blue denim long-sleeved button-up Five Brothers shirt (size 3) numbered "42167" with a Western Costume Co. stamp on the interior, blue jeans (size 25) hand-marked "WCC 25 Prison," and two production tags attached. The costume is intentionally distressed to appear aged with applied grime, mild discoloration, and frayed threads from production use.

Estimate. £1,000 - 1,500



1.09 m
(3.6')



1.09 m
(3.6')

320
Production-Made Andy Dufresne (Tim Robbins) Rita Hayworth and Raquel Welch Posters 
Shawshank Redemption, The (1994)

Production-made Andy Dufresne (Tim Robbins) Rita Hayworth and Raquel Welch posters from Frank Darabont's prison drama The Shawshank Redemption. Dufresne decorated his cell in Shawshank State Prison with posters of his favourite Hollywood actresses, and used them to conceal his escape.

These two rare production-made, back-up posters originated with a recycling vendor for the production. Both are printed on glossy stock. One features Hayworth in black-and-white along with a printed Hayworth signature. The other features Welch in colour from One Million Years B.C. Both are rolled and exhibit edge wear from handling and storage. Dimensions (each): 109.25 cm x 84 cm (43" x 33")

Estimate. £2,000 - 3,000



321
Sherlock Holmes's (Benedict Cumberbatch) Dressing Gown 
Sherlock (T.V. Series, 2010-2017)

Sherlock Holmes's (Benedict Cumberbatch) dressing gown from the crime drama series Sherlock. Sherlock wore his dressing gown as he had tea in his living room with Mrs. Hudson (Una Stubbs) before attending Watson's (Martin Freeman) wedding in the series 3 episode The Sign of Three.

This camel-coloured Derek Rose wool dressing gown is labelled size M and features brown piping around the edge of the collar, cuffs and pockets. It includes a belt with brown fringing at the ends and a printed brand label reading "Derek Rose, Savile Row, London".

The design was custom-made for production. Accompanying this lot is a Hartswood Films certificate of authenticity.

Estimate. £3,000 - 5,000



322
Parasite Display 
Shivers (1975)

A parasite from David Cronenberg's 1975 sci-fi horror Shivers. Several parasites emerged from the body of Nicholas Tudor (Alan Migicovsky) and infected various residents of the luxury apartment complex Starliner Towers. A parasite also emerged from a plughole and infected Betts (Barbara Steele) while she was taking a bath.

Made of foam latex, this slug-like parasite has a short, stubby tail, a barrel-shaped body and an elongated head, at the end of which is a snout. The head features several symmetrical oval and circular protuberances. The midsection of the parasite is encircled by raised lateral bands, suggesting a ribbed thorax, across which run ridges resembling bulging veins. Expertly painted in red, brown and beige, the parasite exhibits intricate detailing, including mucus and scaling, that renders it revoltingly compelling.

The parasite is presented in a display comprising a clear acrylic mount fixed to a black plastic stand, encased in a rectangular acrylic box. Framed within the display are the film poster and a still featuring a parasite crawling between Betts' legs. Also included in the display are the words "SHIVERS - Original film used slug creature".

Dimensions (display): 28 cm x 27 cm x 5 cm (11" x 10 1/2" x 5")

Estimate. £4,000 - 6,000

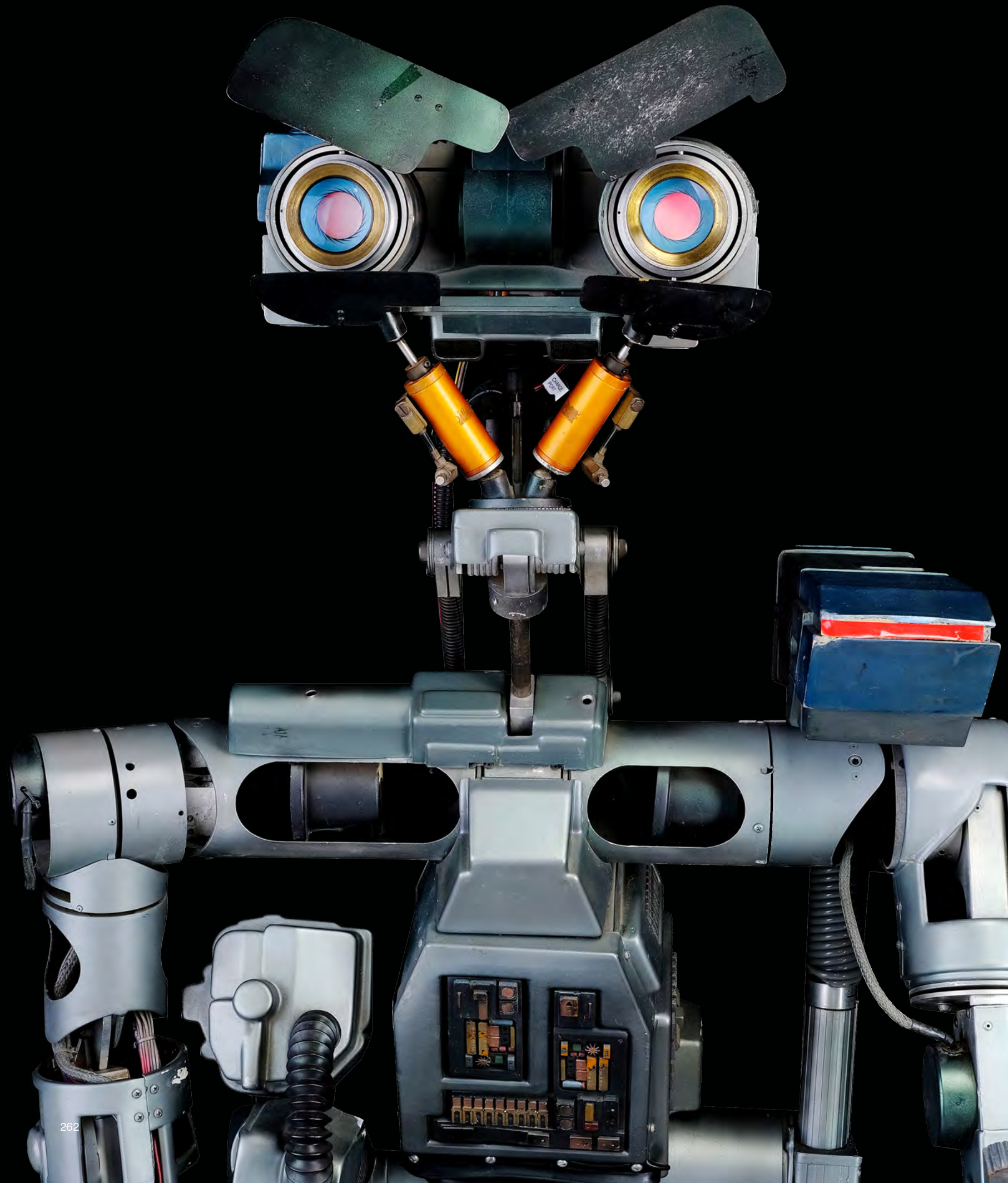

323
Full-Size Light-Up Johnny 5 Robot as
Short Circuit (1986)

A full-size, light-up Johnny 5 robot from John Badham's sci-fi comedy *Short Circuit*. NOVA Laboratory S.A.I.N.T. (Strategic Artificially Intelligent Nuclear Transport) robot Number 5 was struck by lightning and became sentient. After escaping from NOVA, he befriended Stephanie Speck (as played by Ally Sheedy) and adopted the name Johnny 5.

Designed by iconic sci-fi concept artist Syd Mead with influence from sketches by Robotics Supervisor Eric Allard, the Johnny 5 character was realised for the screen through full-size puppets, including remote-control animatronic versions with various movements, and lower-function or static puppets. This Johnny 5 is largely static, with lights in the eyes and servo motors in some of the shoulder and arm components that may have been functional at one time. These lighter-weight static robots were built for use where a heavier piece with additional mechanisms was not necessary, such as action shots of Johnny 5 falling. This Johnny 5 prop retains its original first-film color scheme and detailing, and was not updated for the sequel; it has been intact as a unit since production on the first film. The full-size prop features a blue and grey body made primarily of vacuum-formed plastic and metal with simulated buttons and tech panels on the front and back of the torso. Beneath this outer covering are mechanical and electronic elements, the majority of which are cosmetic though designed to appear practical, including cables and wiring to the mechanisms in his torso and arms, with major connections covered by black rubber bellow-like inserts. His lower body features two plated tread belts in triangular configurations on his left and right sides complemented by two small rear wheels with black rubber tires. Mounted over his left shoulder is a wood and resin laser weapon with a red decal strip on the front to simulate the emitter. The head features orange neck pistons; coloured wires and cables; a blue and grey plating shell matching the body; black metal flaps that serve as upper and lower eyelids; and eyes with gold-colour rings, blue irises reminiscent of camera apertures, and clear lenses that glow red via a small switch in the base of the back of the head. The head has undergone some restoration, specifically to the eyes and their electronics, allowing them to glow with the aid of a rechargeable internal battery that charges through a labelled connector accessible on the back of the head. Also included are original red eye lenses attached to pieces of yellow foam, additional wiring, and a wall-plug charger. Johnny 5 exhibits some wear from production and age, including scuffing, paint chipping, staining, and some loose components. Dimensions: 147.5 cm x 76.25 cm x 17.8 cm (58" x 30" x 7.0")

Contains electronics; see electronics notice in the Buyer's Guide.

Special shipping required; see notice in the Buyer's Guide.

Estimate. £120,000 - 160,000

1.78 m (5.8')

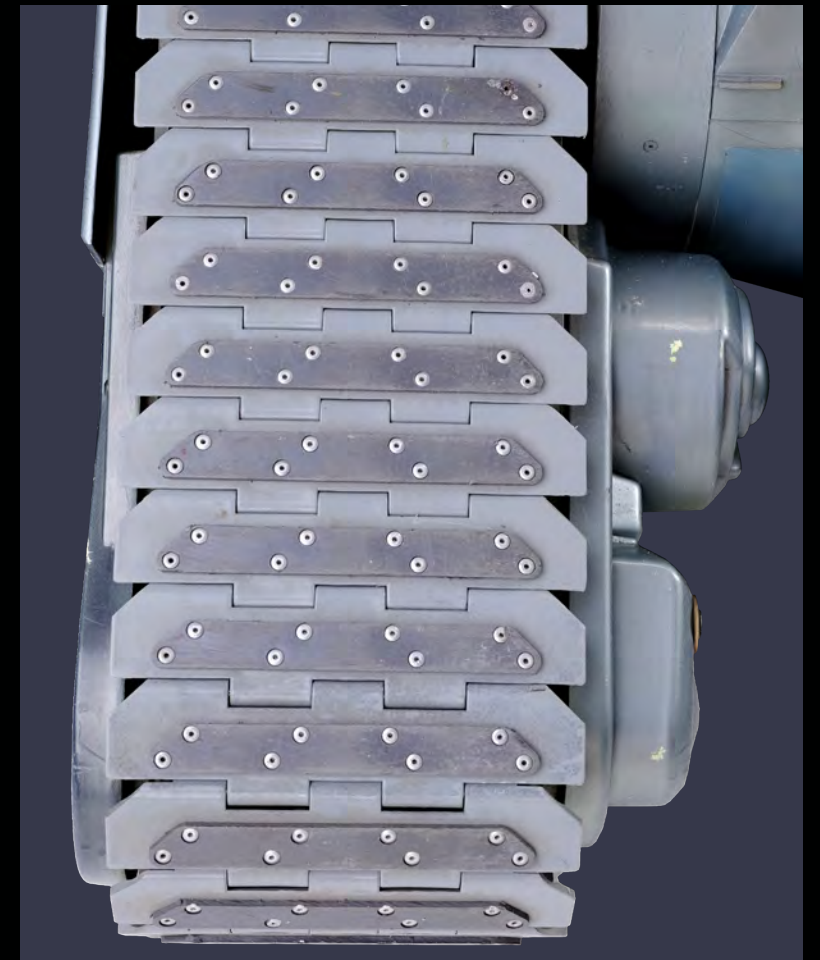

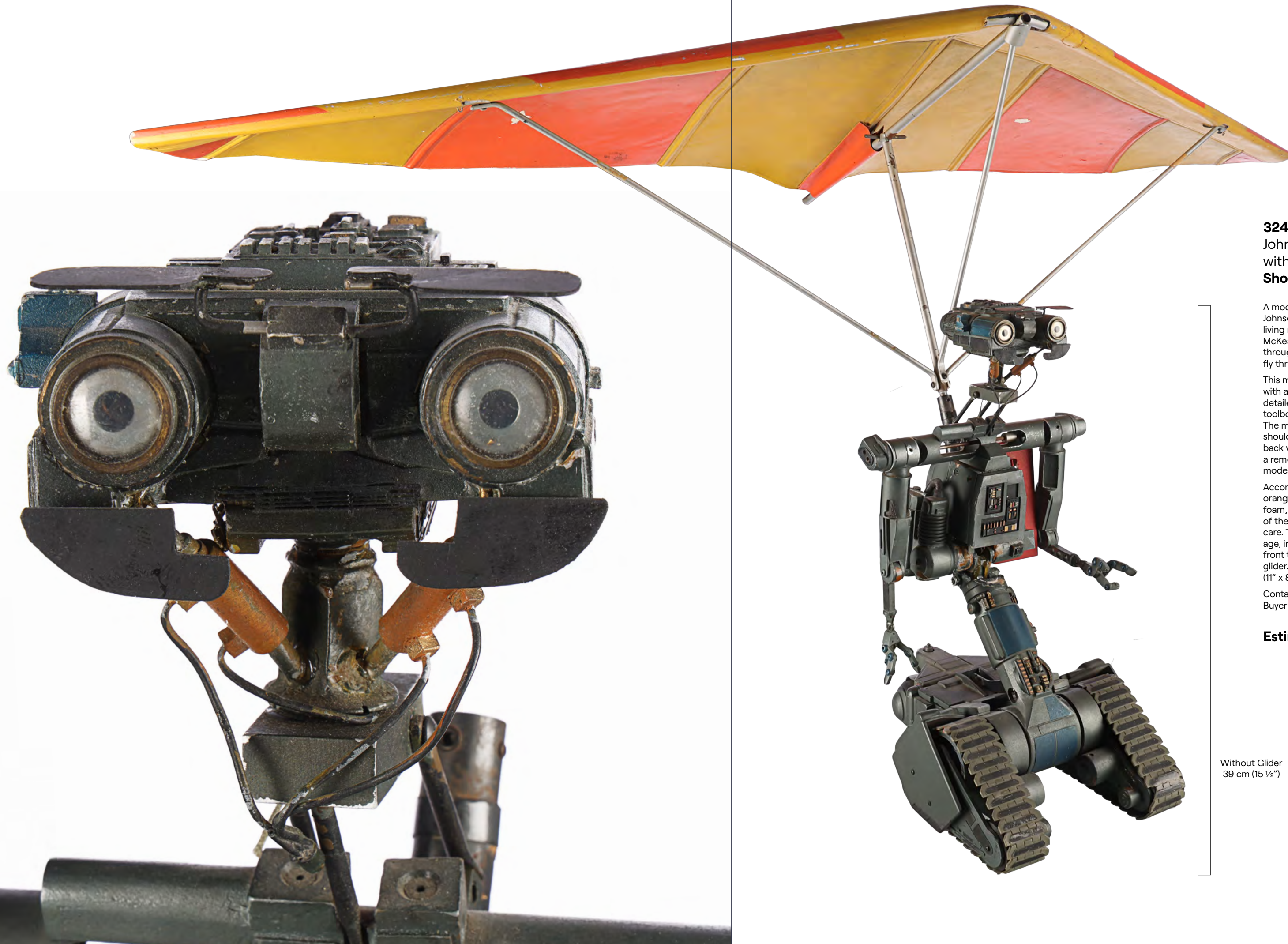

324
Johnny 5 Model Miniature
with Glider M
Short Circuit 2 (1988)

A model miniature Johnny 5 robot from Kenneth Johnson's comedy sci-fi sequel Short Circuit 2. After living robot Johnny 5 learned that Fred (Michael McKean) intended to sell him, he escaped by crashing through an office window and deploying a glider to fly through the city.

This model is mostly made of cast resin and wood, with a metal shoulder bar and joints. It has a highly detailed paint finish in metallic grey, with a red toolbox and bronze-and-blue panels and buttons. The model features a swivelling head, and moveable shoulder joints, elbows, eye guards, toolbox and back wheel. A motor and wiring are present inside a removable front panel on the body, indicating the model was once remote controlled.

Accompanying the model is Johnny 5's yellow-and-orange glider, which is made of resin and biscuit foam, with a metal frame that can slot into the back of the model, though this should be attempted with care. This lot exhibits wear from production use and age, including paint wear, chips, and cracks to the front treads, back wheel guard and surface of the glider. Dimensions (robot): 28 cm x 21.5 cm x 39 cm (11" x 8 1/2" x 15 1/2")

Contains electronics; see electronics notice in the Buyer's Guide.

Estimate. £40,000 - 60,000

Without Glider
 39 cm (15 1/2")



325
 Bughuul (Nicholas King) Hero Mask and Wig Appliance M
Sinister 2 (2015)

A Bughuul (Nicholas King) hero mask and wig appliance from Ciarán Foy's horror sequel Sinister 2. Bughuul was a pagan deity who possessed little children, making them kill their families and film the act.

The mask is a hero version that has been fixed to a lifecast for display purposes. It is made of foam latex, on which dark, lifeless eyes and pale, mottled flesh are hand-painted. The long wig is made of jet black synthetic hair. Dimensions: 20 cm x 47 cm x 38 cm (8" x 18 1/2" x 15")

Estimate. £4,000 - 6,000



326
 Headless Horseman's (Ray Park) Hero Axe M
Sleepy Hollow (1999)

The Headless Horseman's (Ray Park) hero axe from Tim Burton's fantasy horror Sleepy Hollow. The Headless Horseman carried an axe in multiple scenes, notably wielding two axes when he attacked the village midwife Beth Killian (Claire Skinner) and her family in their home. He held this style of axe in his right hand.

The weapon comprises a metal axe head with lighter silver paint applied along the bit, and a long, dark-stained wooden handle. The lot displays scuffing on the handle, scratches on the axe-head, and a mark on the butt. Dimensions: 71 cm x 27 cm x 6 cm (28" x 10 1/2" x 2 1/4")

Estimate. £4,000 - 6,000



327
 Light-up Blue Beetle (Jaren Brandt Bartlett) Costume M
Smallville (T.V. Series, 2001-2011)

A light-up Blue Beetle's (Jaren Brandt Bartlett) costume from superhero TV series Smallville. In the series 10 episode "Booster" teenage boy Jaime Reyes (Bartlett) becomes the host of a strange piece of alien technology in the form of a blue beetle.

The costume comprises a fibreglass helmet with light-up eyes and a detachable faceplate; a pair of fibreglass foam-lined pauldrons; a fibreglass-and-rubber right-hand gauntlet; and a foam-lined fibreglass breastplate, which is fixed together with metal plates and screws, and features mandibles protruding out of the shoulders, a shell design on the back, and insect-leg detailing wrapping around the chest. The helmet eyes light up when powered with a 9V battery. Each piece is airbrushed in royal blue and dark grey, and shows minor paint wear on the edges and breastplate-joining panels.

Contains electronics; see electronics notice in the Buyer's Guide.

Estimate. £6,000 - 8,000

2.1m (6.9')

**328****Full-size Practical Moonbase Alpha Moon Buggy EU
Space: 1999 (T.V. Series, 1975 - 1977)**

A full-size practical Moonbase Alpha moon buggy from the sci-fi television series Space: 1999. In the year 1999, the inhabitants of the moon's scientific research centre, Moonbase Alpha, were thrust into a journey across the galaxy after a nuclear explosion propelled the moon out of Earth's orbit and into deep space. During these adventures, the crew used moon buggies to travel on the lunar surface, and even the terrain of alien planets.

There is only one full-size drivable Moon buggy known to have been used in the show. It is seen in the Series 1 episodes "Breakaway" and "The Full Circle", and the Series 2 episodes "Space Warp" and "The Bringers of Wonder, Part Two".

The moon buggy is actually an amphibious vehicle called the Amphicat, made by Behoo Industries in Ontario, Canada. It is constructed from a two-piece ABS plastic moulded body shell with a working 16hp Sachs air-cooled petrol engine, six wheels and an exhaust on the right-hand side. Three knobs operate the buggy on the left side of the dashboard, which features two control sticks. Originally red, the vehicle was painted yellow by production designer Keith Wilson so it would be more visible on the lunar sets. The buggy retains this paintwork, along with the decals added for the show. These include a black-and-yellow striped trim; two small number "8" decals; two large number "5" decals (added in Series 2); an "Alpha Moonbase" badge at the front of the left side; a number of coloured "Airlock" controls on the dashboard (added in Series 2); and a striped multicoloured space crest on the front, back and left side of the vehicle. Additional decals have been added subsequent to production.

The moon buggy initially had wing mirrors in Series 1, but these were removed for Series 2.

The front of the buggy features Nick Tate (Alan Carter) and Catherine Schell's (Maya) autographs in black pen, along with handwritten inscriptions from each actor. These read, "I drove the Moonbuggy on the moon", and "I never drove in this buggy - but I like it!", respectively. The buggy has never been restored and retains its original tyres and paintwork.

Accompanying this lot is a Certificate of Authenticity from Cars of the Stars Motor Museum, and a promotional still of lead actors Barbara Bain and Martin Landau with the moon buggy. The lot requires a replacement battery and exhibits wear from production use and age, including the missing wing mirrors, paint wear and surface scuffs and scratches. Dimensions: 210 cm x 135 cm x 85 cm (82 ¾" x 53 ¼" x 33 ½")

Additional Provenance: Between 1977 and 1981, the moon buggy was displayed at the Blackpool Space City exhibition alongside many other models, props and costumes from Space: 1999. It was then exhibited at the theme park Alton Towers in the UK from 1982 to 1989, until it was acquired by Gerry Anderson prop collector Phil Rae. The Cars of the Stars Motor Museum purchased it from Rae and it resided in their collection for around 10 years until the museum closed in 2005.

This lot is stored off-site, outside Prop Store's primary facility. It will ship from its current location to the buyer's location, at the buyer's expense. This lot will not be available to view before the auction without special arrangement. The buyer is responsible for the shipping costs of all lots, regardless of the lot storage location. Please contact Prop Store for a shipping quote prior to bidding for off-site storage lots.

Special shipping required; see special shipping notice in the Buyer's Guide.

Contains mechanical components; see mechanical notice in the Buyer's Guide.

Estimate. £80,000 - 120,000

I never drove in this buggy - but I like it!
 Catherine Schell
 otherwise known as
 "Maya"



I DROVE THIS MOONBUGGY
 ON THE MOON *Walt Terz*



Shutterstock



329
 Terran Federation Starship Miniature Model M
Blake's 7 (T.V. Series, 1978 - 1981)

A Terran Federation starship miniature model from BBC sci-fi series Blake's 7. In the Series 4 episode "Sand", the Federation sent a crew to explore the planet Virn after members of a previous expedition died of a mysterious virus. Upon arriving their ship was buried in a peculiar sand slide.

This miniature model was built by model maker Bill Pearson at the BBC Visual Effects Department and is constructed from cast resin and plastic. It is the only model ever made for production and was inspired by Ron Cobb's original conceptual design for the Nostromo in Ridley Scott's sci-fi film Alien. Hand-painted yellow with a grey underbelly and red, silver and black decals, it also displays sections of faint grey spray paint to create a weathered look. It features tiltable, rotatable feet and extendable legs; a silver decal on the front of the right arm reading "FT7"; and a Federation emblem decal on the left side. In some scenes, a satellite dish can be seen extended from the dome located on the top of the craft. The dome on this model is removable and lightly held in place by black putty, so it could easily be interchanged with the satellite dish during filming. However, this component is missing from this model. The starship exhibits wear from production use and age, including small areas of flaked and scuffed paint, two peeling decal strips, and a broken antenna on the front left. Dimensions: 106 cm x 55 cm x 31.5 cm (41 3/4" x 21 3/4" x 12 1/2")

Special shipping required; see special shipping notice in the Buyer's Guide.

Estimate. £10,000 - 15,000



330
 Emma Anderson's (Whitney Houston) Costume
 and Poster M
Sparkle (2012)

Emma Anderson's (Whitney Houston) costume and a promotional poster from Salim Akil's musical Sparkle. Emma wore her costume while hosting a Bible study group at her home, where she preached about dancing suggestively and the costume also features in the trailer for the film. Sadly, this would be Houston's last film performance before her untimely death in February 2012.

This costume worn by Whitney Houston comprises a vintage Rona New York camel-coloured woollen jacket and a matching high-necked fitted midi dress. The one-sheet poster features Sparkle (Jordin Sparks) in a red dress with several images of cast members, including Houston, situated under the film title.

Both garments have Palace Costume Company labels adhered to their interiors. The costume displays minor stains and is accompanied by a letter of authenticity signed by the CEO of the Palace Costume Company. Dimensions (poster): 101 cm x 68.5 cm (39 3/4" x 27")

A portion of the hammer proceeds from this item are being donated to the National Autistic Society.

Estimate. £4,000 - 6,000



331
 Crixus' (Manu Bennett) Battle Costume Display 1A
Spartacus: Blood And Sand (T.V. Series, 2010)

Crixus' (Manu Bennett) Battle costume from the Starz historical series Spartacus: Blood and Sand. The "Undefeated Gaul" wore his attire during his battles in the arena, notably when he and Spartacus (Andy Whitfield) fought Theokoles (Reuben De Jong) in the episode "Shadow Games".

The costume comprises a gold-coloured fibreglass helmet featuring a brown plume; a chain-mail manica with embellished red leather straps (labelled "Crixus", with the word "Double" crossed out); an additional leather shoulder strap; an Aztec-print fabric sash; a cotton gauntlet; a red leather belt with metal details (labelled "Crixus Hero"); a pair of burnt-orange cotton pads; and a pair of ornate, bronze-coloured fibreglass greaves. Exhibiting intentional distressing, the costume is presented on a custom-made display featuring the series' title artwork, which illuminates via a switch at the back of the base. The lot is accompanied by five Starz certificates of authenticity. Dimensions (displayed): 50 cm x 56 cm x 229 cm (19 3/4" x 22" x 90 1/4")

Contains electronics; see electronics notice in the Buyer's Guide.

Special shipping required; see special shipping notice in the Buyer's Guide.

Estimate. £4,000 - 6,000



332
Venom (Topher Grace) Prototype Costume Display 1A
Spider-Man 3 (2007)

A Venom prototype costume from the production of Sam Raimi's superhero sequel Spider-Man 3. Photographer Eddie Brock transformed into Venom when the extraterrestrial symbiote was removed from Peter Parker (Tobey Maguire) and fell onto Brock in a church bell tower. This suit was a prototype version of the final costume, and promotional photos exist of Grace wearing a prototype Venom costume of this style.

The full-body suit is made from dark purple and black Spandex featuring a honeycomb pattern all over with grey-painted foam rubber web detailing. A spider emblem adorns the front and back of the torso. The head includes a large pair of eyes and a set of fanged teeth. Cast resin claws are embedded in each finger, and the feet consist of split-toe tabi shoes covered in the Spandex material. Presented on a custom display mannequin, the costume exhibits minor cracking and paint wear to the web detailing, and some of the Spandex is missing around the mouth. Dimensions (displayed): 177 cm x 56 cm x 45 cm (69.75" x 22" x 17.75")

Special shipping required; see notice in the Buyer's Guide

Estimate. £10,000 - 15,000





333
Hero Light-up Green Goblin (Willem Dafoe)
Pumpkin Bomb Ω
Spider-Man (2002)

A hero light-up Green Goblin (Willem Dafoe) pumpkin bomb from Sam Raimi's superhero film Spider-Man. After transforming himself into the supervillain known as the Green Goblin, industrialist Norman Osborne used his signature pumpkin bombs as explosives and bladed weapons, among other offensive effects.

This spherical orange device is primarily made of metal around a plastic inner sphere and features a button at the top which makes the bomb flash bright green when pressed. Eight LED lights also illuminate in sequence. The bomb has been intentionally distressed and also features additional paintwear. The lot also comes with an acrylic display case. Dimensions: 8 cm x 8 cm x 7.5 cm (3 1/4" x 3 1/4" x 3")

Contains electronics; see electronics notice in the Buyer's Guide.

Estimate. £8,000 - 12,000



334
Black Symbiote Spider-Man Mask Ω
Spider-Man 3 (2007)

A symbiote Spider-Man mask from Sam Raimi's superhero sequel Spider-Man 3. A mysterious alien symbiote fell to earth on a meteorite and bonded with Peter Parker (Tobey Maguire), altering his costume, enhancing his powers, and influencing his behaviour for the worse.

This black mask is made in a similar design to the classic Spider-Man suit. It features a honeycomb pattern, foam web detailing, and sections of metal webbing fastened behind large, plastic eyepieces. The letter "C" is handwritten on a torn label sewn to the interior at the nape of the neck.

This mask comes presented over a hair net on a black biscuit-foam bust. There is wear from production use, including small fissures and wear to the foam webbing, while the top corner of the left eye's frame has come unstuck. Dimensions: 24 cm x 27 cm x 44 cm (9 1/2" x 10 3/4" x 17 1/4")

Estimate. £8,000 - 12,000



335
Spock's (Leonard Nimoy)
Bridge Uniform M
Star Trek: The Motion Picture (1979)

Spock's (Leonard Nimoy) bridge uniform from Robert Wise's sci-fi film Star Trek: The Motion Picture. Spock wore his uniform while on board the newly refitted USS Enterprise.

The two-piece uniform comprises a grey panelled jacket with a zip at the back, and matching grey trousers with built-in shoes. The jacket has a silver-and-orange Starfleet insignia patch on the left chest and gold ranking braids on the cuffs. A resin-and-biscuit-foam "life support" device is attached to the front of the jacket. Both pieces feature Western Costume labels, on which are printed production numbers and "Lenord [sic] Nimoy".

The uniforms were redesigned from the original series of Star Trek by costume designer Robert Fletcher, with the aim of making them better and more believable for the big screen. The costume has some very minor staining, on the chest, shoes and elsewhere.

Estimate. £10,000 - 15,000

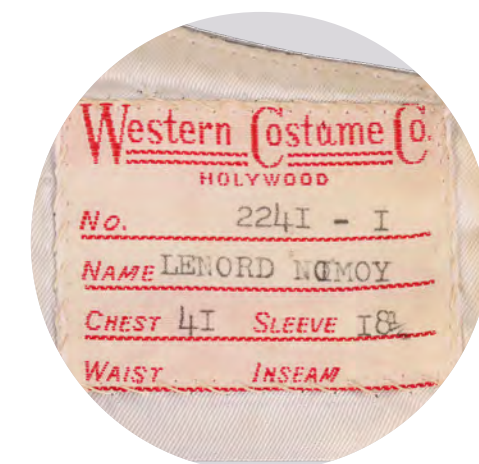

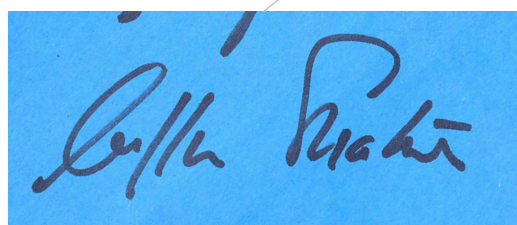
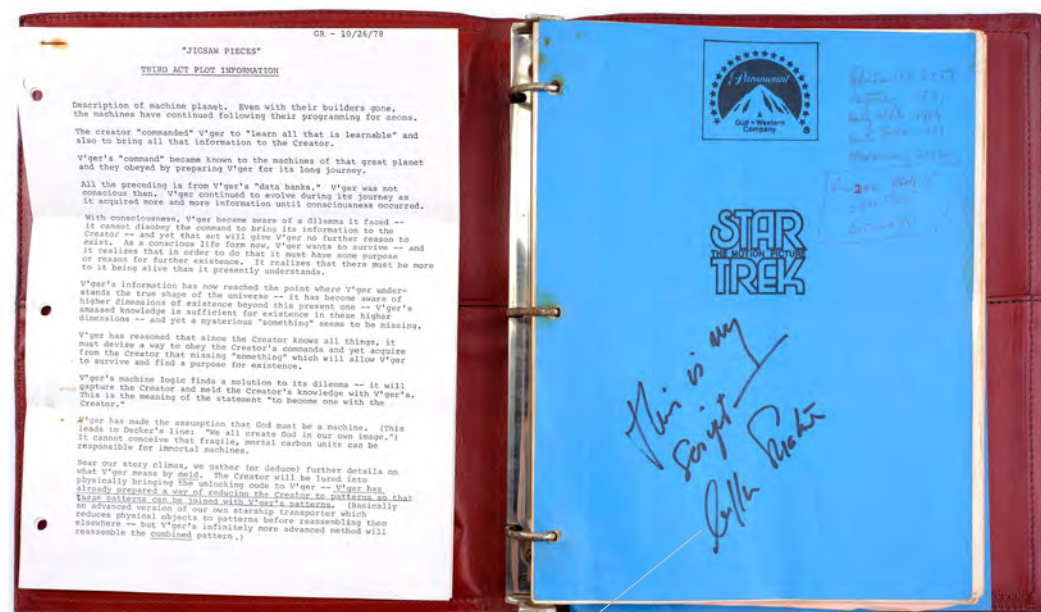

336
 William Shatner's Signed Personal Shooting Script
 Star Trek: The Motion Picture (1979)

William Shatner's signed personal shooting script from the production of Robert Wise's sci-fi film Star Trek: The Motion Picture. Shatner used his script throughout the film's principal photography. This script was auctioned off by Shatner for charity in 2000. It features a red leather cover reading "Star Trek" and "W.S." Inside are 161 colour-coded script pages, a folded two-page third act plot information packet, a two-page list of computer voice acknowledgements, and a five-page shooting schedule. There are handwritten notations throughout, and the title page is signed "This is my script - William Shatner" in black ink. The script exhibits scuffing to the cover, staining and edgewear to the pages, and discolouration to the metal binding components. Dimensions: 25.5 cm x 30.5 cm x 5.25 cm (10" x 12" x 2")

Estimate. £5,000 - 7,000



337
 Dr. Leonard McCoy's (DeForest Kelley) Uniform
 Star Trek: The Motion Picture (1979)

Dr. Leonard McCoy's (DeForest Kelley) uniform from Robert Wise's sci-fi film Star Trek: The Motion Picture. McCoy wore his uniform while onboard the newly refitted USS Enterprise. This two-piece uniform consists of a grey panelled tunic and matching grey trousers and grey shoes. The tunic has a silver-and-green Starfleet insignia patch on the left chest as well as replicas of gold-colour Original Series rank braids added to its cuffs after production for display. The tunic has a vacuum-formed plastic "life support" device attached to its front and features a Western Costume label with production numbers and "DeForest Kelly [sic]" printed on it. The trousers have "DeForest Kelly" handwritten in the waistband. The shoes are a pair of black trainers glued into the same grey material as the rest of the uniform.

Costume designer Robert Fletcher designed the uniforms differently to those seen in Star Trek: The Original Series, with the aim of making them better and more believable for the big screen. A Paramount Pictures certificate of authenticity accompanies the costume.

Estimate. £5,000 - 7,000

1.5 m (4.8')

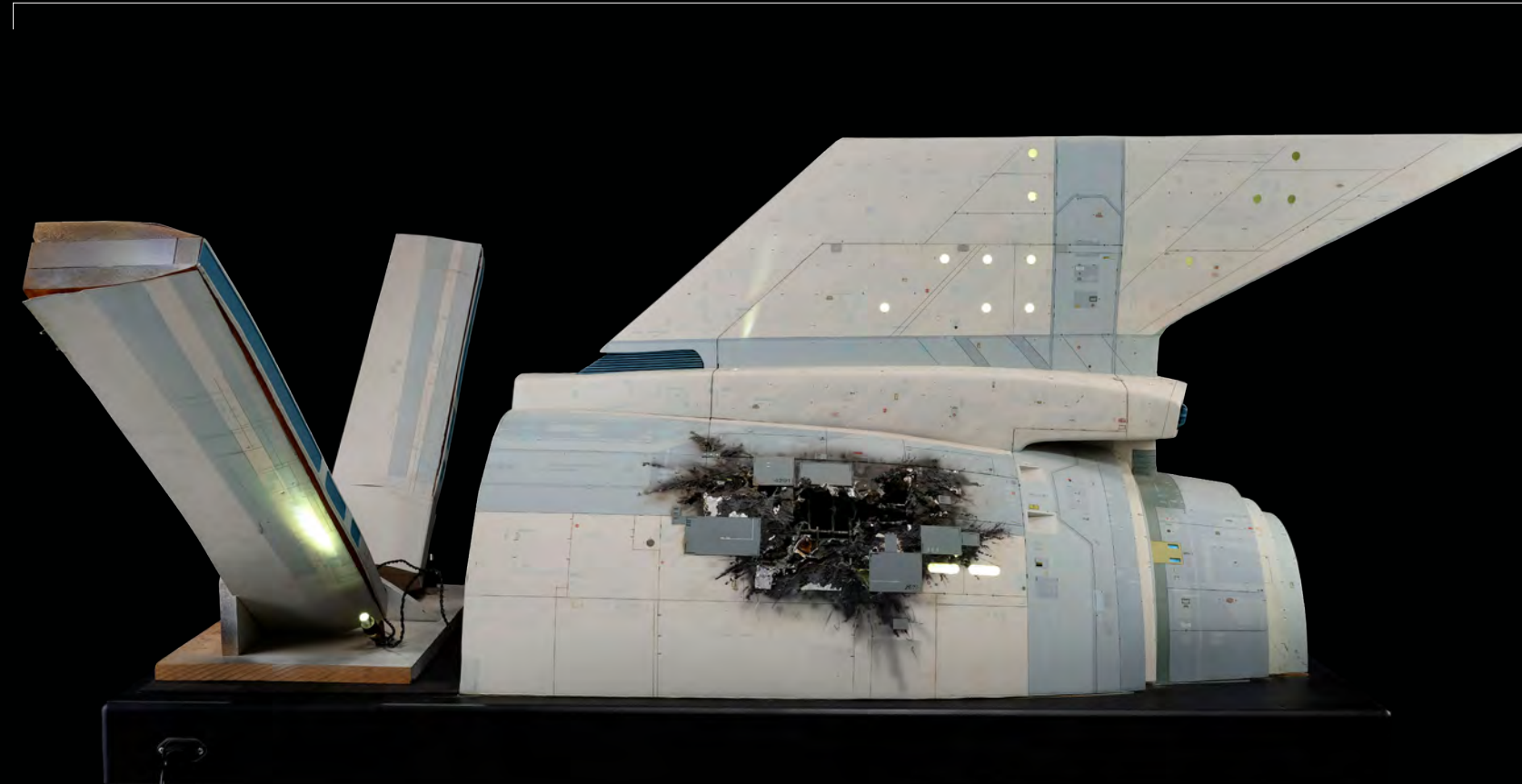

338
 Screen-matched Light-up Battle-damaged USS Enterprise Hull Insert Model Miniature
 Star Trek II: The Wrath Of Khan (1982)

A screen-matched, light-up, battle-damaged USS Enterprise hull insert section model miniature display from Nicholas Meyer's Star Trek II: The Wrath of Khan, its immediate sequel, Star Trek III: The Search for Spock, and Star Trek VI: The Undiscovered Country. After taking control of the USS Reliant, Khan Noonien Singh (Ricardo Montalban) opened fire on the Enterprise's secondary hull, severely crippling the ship.

While models of the Enterprise from the production of Star Trek: The Motion Picture were used throughout filming, this ornately detailed, hand-painted model miniature was constructed by Industrial Light & Magic (ILM) to appear specifically battle-damaged during the attack sequence in The Wrath of Khan. It was then reused for insert shots of the ship in both The Search for Spock and The Undiscovered Country. The battle-damaged section screen-matches to shots in the third film, while its many lights screen-match to shots in the sixth.

This electronic display consists of the hull section model miniature and two plastic-panelled wood wing pieces with miniature illuminating spotlights all mounted to a particleboard base marked "These bulbs are 3 1/2 volts max!" designed to control small lights installed throughout the model. The electronic base features two Starfleet emblems and five switches labelled "Main", "Interior Lights", "Exterior Lights", "Arm Photon", and "Fire Torpedo" which activate various illuminating sections of the hull.

The model itself is constructed of resin, wood, paper, and panelled plastic with internal steel and aluminium components, some of which are exposed around the battle-damaged area. It is painted grey and blue with red, blue, white, black, and yellow decals applied throughout, and lined with lights. The lot exhibits some signs of use and handling, including scuffed and discoloured paint, loose panelling, and scratched wood. Dimensions: 139.75 cm x 147.5 cm x 76.25 cm (55" x 58" x 30")

Contains electronics; see electronics notice in the Buyer's Guide.

Special shipping required; see special shipping notice in the Buyer's Guide.



Estimate. £10,000 - 15,000



339
 Communicator 
Star Trek V: The Final Frontier (1989)

A communicator from William Shatner's sci-fi sequel Star Trek V: The Final Frontier. Starfleet personnel, such as James T. Kirk (William Shatner) and Hikaru Sulu (George Takei), used their communicators to contact the Enterprise.

This communicator, very reminiscent in design to the classic communicators used on the original series, features a black resin body with sculpted buttons in silver-colour with red and blue decals, a brass-colour metal grate cover that flips open via a hinge, and a metal belt clip on the back. The communicator exhibits paint chipping, scuffing on the belt clip, and some bending of the grate bars. Dimensions: 10.25 cm x 6.5 cm x 4.25 cm (4" x 2.5" x 1.75")

Estimate. £4,000 - 6,000

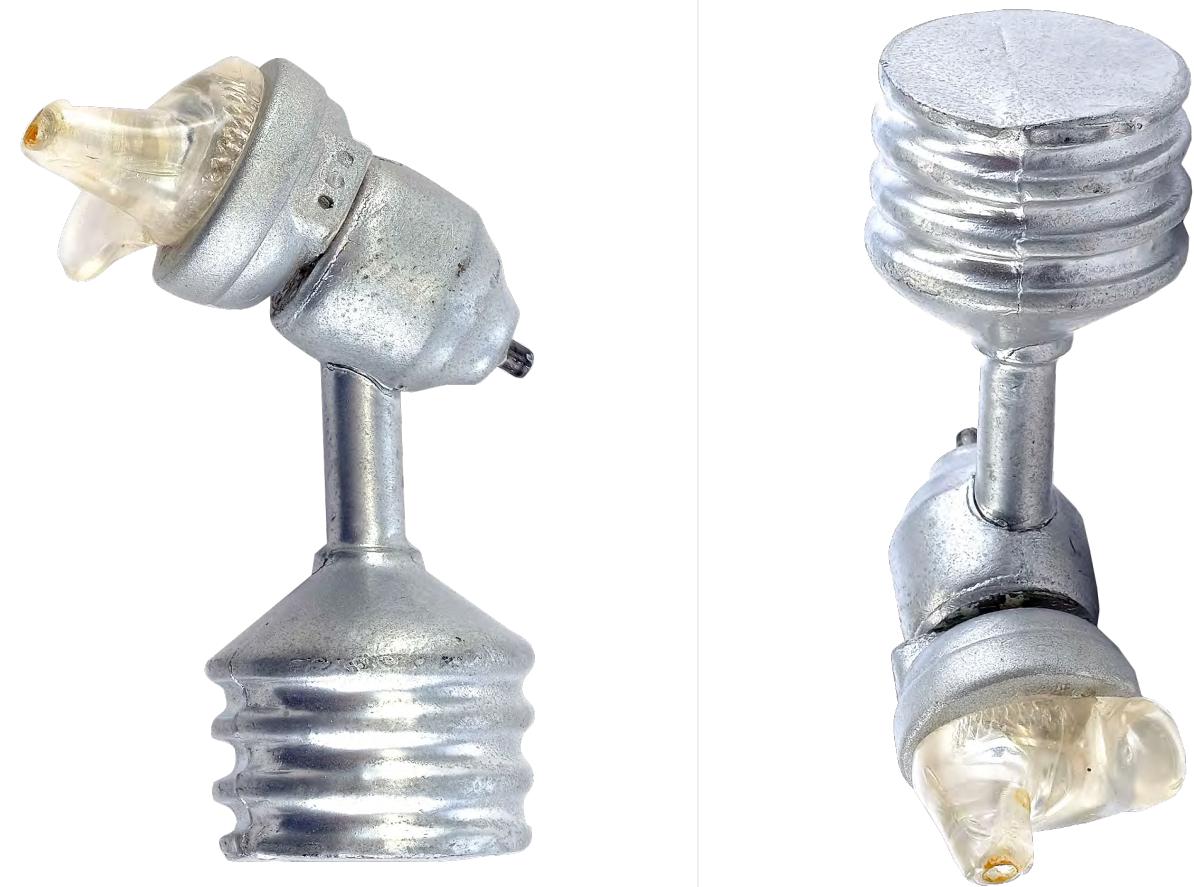

340
 Uhura's (Nichelle Nichols) Earpiece 
Star Trek VI: The Undiscovered Country (1991)

Uhura's (Nichelle Nichols) earpiece from Nicholas Meyer's sci-fi sequel Star Trek VI: The Undiscovered Country. Uhura wore her earpiece as she once again took on the position of communications officer of the Enterprise-A for the last time during the Khitomer crisis.

Although Uhura often used a metal earpiece, Paramount Pictures archivist Penny Juday identifies earpieces of this style as Uhura's in the "Penny's Toy Box" special featurette from the DVD release. This earpiece consists of a hollow, cast-resin main body painted silver-colour, with a rotating clear plastic ear insert, a simulated black button, and the word "Stanton" inscribed beneath the clear insert. It exhibits minimal paint chipping, some staining on the clear plastic, and a slight rattle from a loose piece inside. Dimensions: 7.75 cm x 5.25 cm x 2.75 cm (3" x 2" x 1")

Estimate. £5,000 - 7,000



341
Light-up Hero Starfleet Phaser †Δ
Star Trek Into Darkness (2013)

A light-up hero Starfleet phaser from J.J. Abrams' sci-fi sequel Star Trek Into Darkness. Phasers were a standard-issue weapon for Starfleet personnel.

The phaser is made mostly of resin with a chrome finish on the handle. A light on the top of the weapon illuminates when connected to its battery pack, and changes colour between red, orange and green when the phaser's scroll wheel is turned.

Its barrel can be spun between the "lethal" and "stun" settings, although the function to automate this no longer works, and the top of the phaser slides off, revealing the battery compartment. The phaser has some scuffing and scratches to the paint, most notably on the top. It comes with a charger for the battery pack and a custom-made display stand. Dimensions: 27 cm x 5 cm x 18 cm (10 ½" x 2" x 7")

Contains electronics; see electronics notice in the Buyer's Guide.

Estimate. £5,000 - 7,000



342
Klingon Guard Costume Display †Δ
Star Trek Into Darkness (2013)

A Klingon guard costume display from J.J. Abrams' sci-fi sequel Star Trek Into Darkness. Klingons wore their uniforms when they encountered the crew of the U.S.S. Enterprise in search of John Harrison (Benedict Cumberbatch) on the planet Kronos.

This costume consists of a breastplate; a pair of shoulder guards with an elastic harness; a scarf; a long-sleeved shirt (size XL); an undershirt (size XL); a pair of gloves; a pair of arm bracers; a codpiece; a pair of trousers (approximate waist size 28); a pair of thigh guards; a pair of knee pads; a helmet; a Klingon disruptor; and a pair of boots (US size 15).

The breastplate, shoulder guards, thigh guards, knee pads, arm bracers and codpiece are all made of foam rubber and mimic elephant hide by incorporating faux leather created from China silk and terry cloth. The scarf is made of a synthetic material and is lined with spandex. The long-sleeved shirt is a black spandex sports shirt with glossy, textured sleeves made of faux leather, while the undershirt is also a black Spandex sports shirt, and the gloves are made of black leather and suede.

The trousers are the same textured synthetic material as the sleeves and include black nylon suspenders. The helmet is made of dense urethane and is finished in metallic silver and grey. The boots are made of black neoprene and rubber, and are distressed with dirt. The disruptor is painted in metallic shades of silver and is made of foam urethane.

The costume has been mounted on a custom-made display featuring the film's title. It features handwritten wardrobe labels, with many of the pieces marked with the actor's name. Also included are wardrobe tags with handwritten notes about the costumes. Dimensions (displayed): 40 cm x 64 cm x 204 cm (15 ¾" x 25 ¼" x 80 ¼")

Special shipping required; see special shipping notice in the Buyer's Guide.

Estimate. £5,000 - 7,000



343
Captain James T. Kirk's (Chris Pine) Starfleet Uniform Tunic Ω
Star Trek Into Darkness (2013)

Captain James T. Kirk's (Chris Pine) Starfleet uniform tunic from Star Trek Into Darkness. Kirk, the captain of the Enterprise, wore his iconic yellow tunic throughout the film.

This lot consists of a yellow Spandex-blend tunic. It features yellow satin-covered piping around the collar and armholes, silver-colour decals around the wrists, and a printed optical repeat of the Starfleet insignia pattern on the fabric. The back left shoulder also features a hidden zipper. This lot exhibits some loose threads, minor discolouration, and unravelled fabric from production.

Estimate. £4,000 - 6,000



344
Enterprise Bridge Uniform with Sulu's (George Takei) Trousers M
Star Trek (T.V. Series, 1966-1969)

An Enterprise bridge uniform with Sulu's (George Takei) trousers from the sci-fi TV series Star Trek. Starfleet officers wore their uniforms throughout the series.

The uniform comprises a command lieutenant's top and a pair of trousers. The gold velour top features a black ribbed collar; the Enterprise insignia; an invisible zip hidden along the front right seam; and a single braided stripe at the end of each sleeve. Sulu's trousers are made from a shimmering black material, with a costumer's label in the waist's interior and strips of Velcro sewn into the hip and waist. Takei's name is handwritten in white pen on the inside of the waistband.

Also included are a pair of custom-heeled black leather boots, added to complete the look of the costume. They each feature "Colm" handwritten in blue pen on a strip of tape, indicating that they were worn by Colm Meaney, who appeared as Chief Miles O'Brien in later series Star Trek: The Next Generation and Star Trek: Deep Space Nine. This uniform displays wear from production use and age. The top exhibits minor staining to the front and back, some unstitching of the seams, and signs of a repaired tear at the back. Each boot is scuffed around the toe.

Estimate. £6,000 - 8,000



345
No Lot

346
Spock's (Leonard Nimoy) Complete Costume +
Star Trek: Phase II (1978)

Spock's (Leonard Nimoy) complete costume from the unproduced TV series Star Trek: Phase II. The series was initially planned as a follow-up to the original series (1966-69), reuniting the cast and adding a few new USS Enterprise crew members.

Nimoy's costume was made by modifying pieces used on the original series. It consists of a blue tunic (designating a science or medical officer), black trousers and black boots. The tunic is labelled "42 34" in the collar and each boot has "LN" handwritten on its interior. The tunic features some very minor staining.

Estimate. £7,000 - 10,000



347
Q's (John de Lancie) Starfleet
Admiral Tunic M
Star Trek: The Next Generation
(T.V. Series, 1987-1994)

Q's (John de Lancie) Starfleet admiral tunic from sci-fi series Star Trek: The Next Generation. Q wore his tunic at the beginning of the Season 1 episode "Hide and Q" as he trapped the Enterprise crew in a forcefield and forced them to play his games.

The burgundy tunic features a shiny gold-and-silver trim around the collar and down the front. A zip runs up the front along the trim, and poppers fasten across the chest. Stitched into the collar is a label reading "John De Lancey[isic]" handwritten in black ink. The tunic is accompanied by a board autographed by Patrick Stewart (Jean-Luc Picard) and de Lancie, with each actor writing a line of their dialogue from the episode: "You're no Starfleet Admiral, Q" and "Neither am I an Aldebaran serpent, Captain, but you accepted me as such!" The tunic features some minor staining and the badge is a replica.

Estimate. £4,000 - 6,000

348
Main Engineering Master Systems
Display Table LCARS Keypad
Panel 02 Ω
Star Trek: The Next Generation
(T.V. Series, 1987 - 1994)

A Main Engineering master systems display table LCARS keypad panel from the sci-fi series Star Trek: The Next Generation. Chief Engineer Geordi La Forge (LeVar Burton) and his team used the master systems display table in Main Engineering as they investigated issues with the Enterprise-D.

Designed to appear illuminated when backlit, this black acrylic panel features graphics paper labelled "Subsystem Operational Status" with simulated yellow and purple touch-screen buttons in the series' iconic LCARS (Library Computer Access and Retrieval System) style taped to the back. It exhibits scratching throughout, and the tape is loose in places. Dimensions: 29.25 cm x 19 cm x 0.75 cm (11.5" x 7.5" x 0.25")

Estimate. £4,000 - 6,000

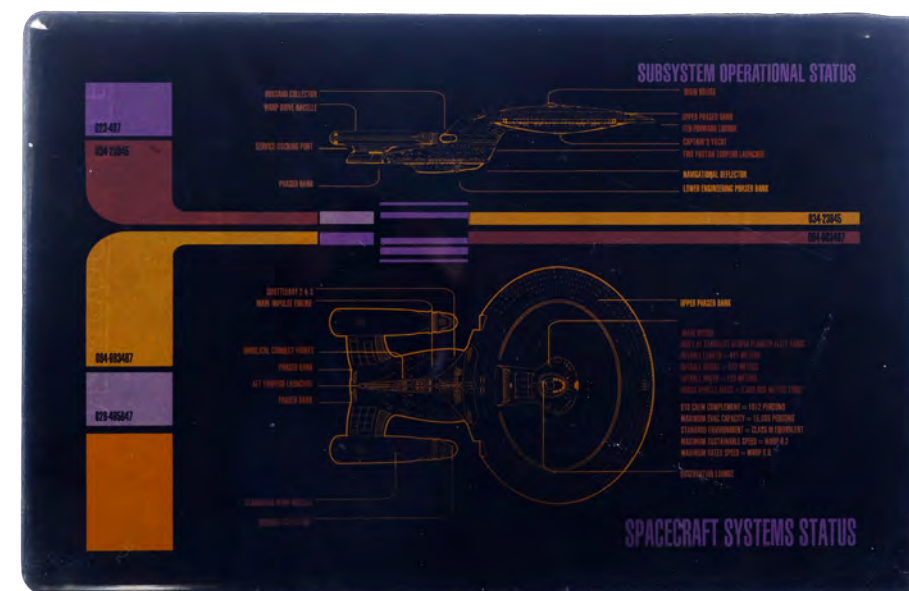

103 m (3.4')

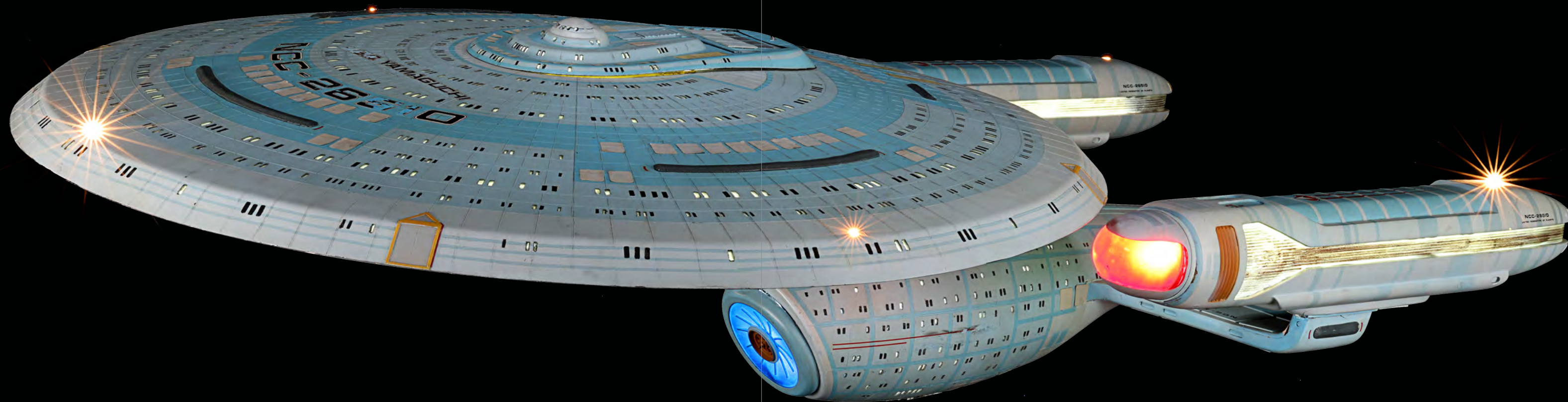
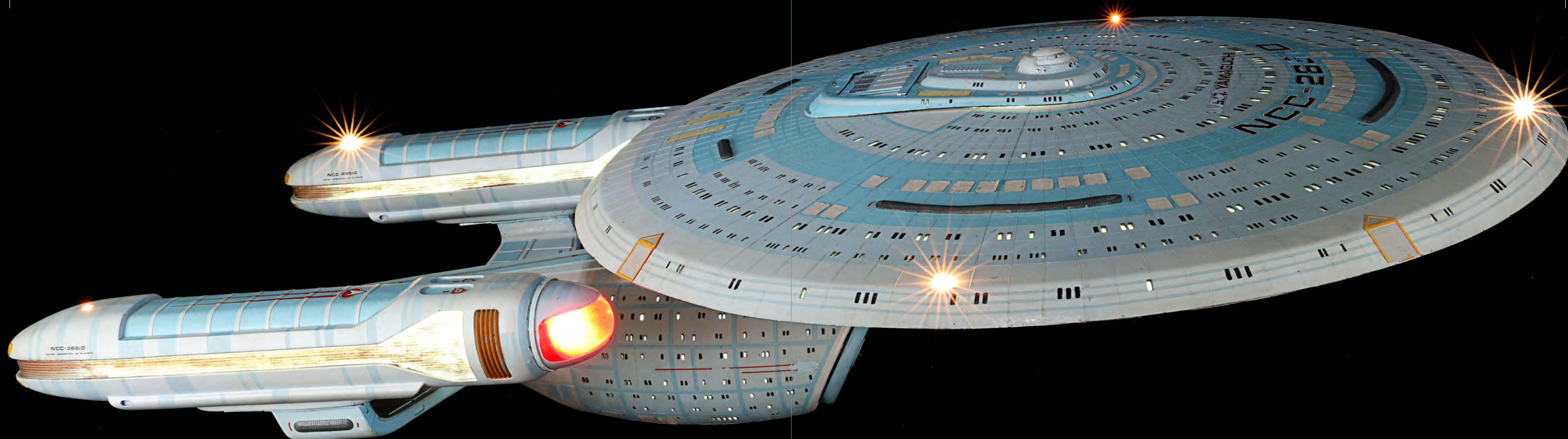

349

**Light-up USS Yamaguchi and Excalibur Model Miniature |
Star Trek: The Next Generation (TV Series, 1987-1994)**

A USS Yamaguchi and Excalibur light-up model miniature from sci-fi TV series Star Trek: The Next Generation. This miniature of the Ambassador-class starship was built to serve as two Federation ships, including the U.S.S. Excalibur in the Season 5 episode "Redemption II" and the U.S.S Yamaguchi which appeared in the first episode of Star Trek: Deep Space Nine. The saucer top is currently marked as "U.S.S. Yamaguchi NCC-26510", and the rear of the model is still marked "Excalibur".

The model is made from cast resin reinforced with fibreglass, and features styrene detailing. It sits on a metal display stand and features two wires protruding from the bottom. The starship illuminates when powered. The model is accompanied by its original wooden crate which has "Enterprise 'C'" handwritten in blue ink in two places, and "Trek TV" handwritten or stamped in two other areas.

Well-used in the Star Trek saga, certain decals have come away or show wear from use and age, with the model exhibiting minor cracks and wear to the paint finish.

Dimensions (model): 103.5 cm x 68 cm x 20 cm (40 3/4" x 26 3/4" x 8")

Contains electronics; see electronics notice in the Buyer's Guide.

Special shipping required; see special shipping notice in the Buyer's Guide.

Estimate. £50,000 - 80,000

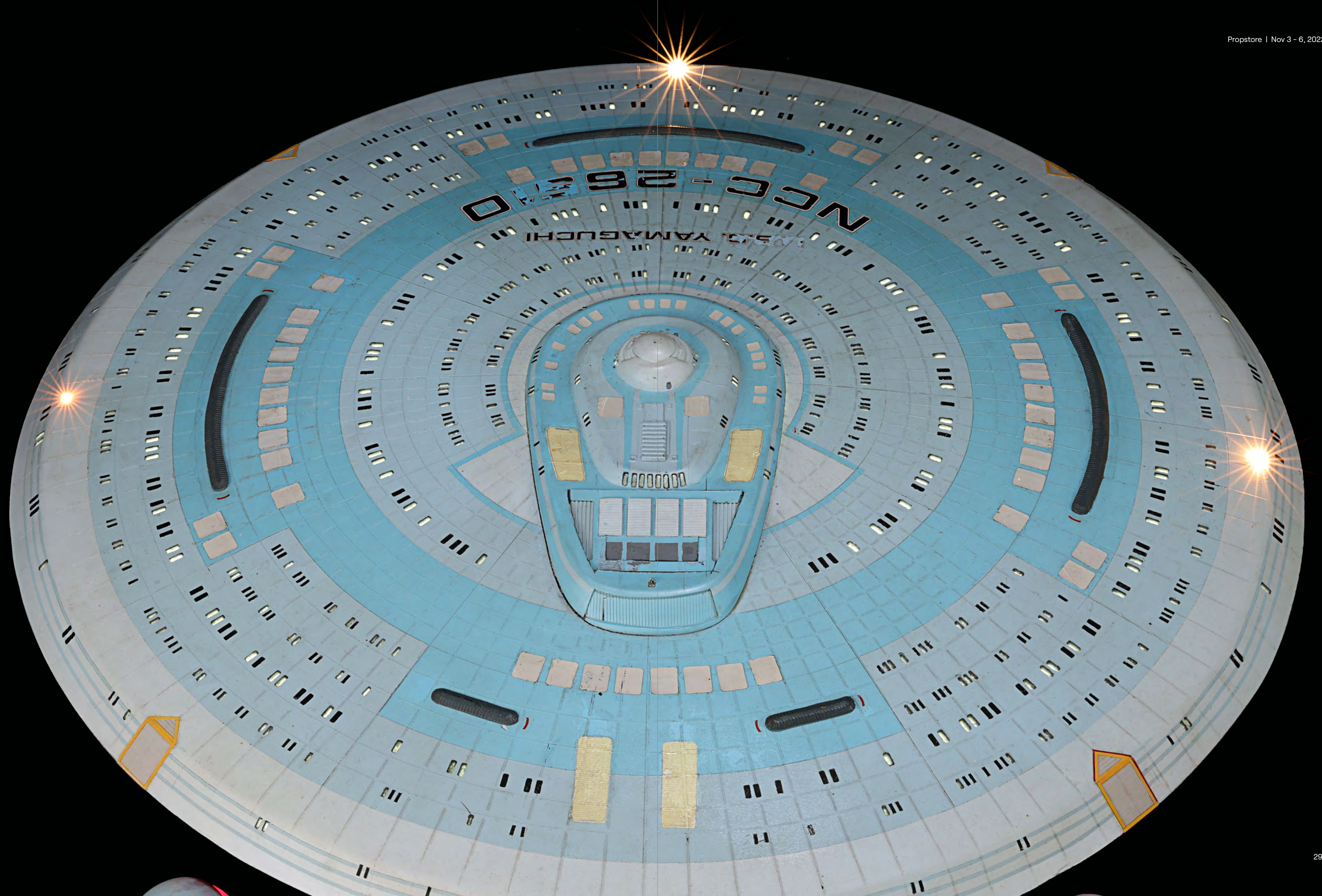

2 m (6.6')

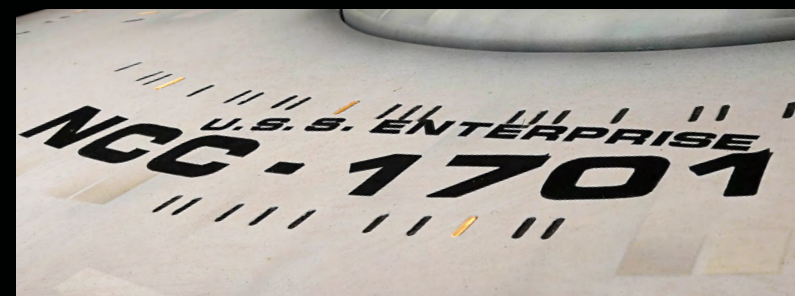

350
 Replica Studio-scale Light-up Model Miniature
 USS Enterprise \mathcal{M}
Star Trek: The Next Generation (T.V. Series, 1987-1994)

An impressive replica, studio scale light-up model miniature of the USS Enterprise inspired by the sci-fi TV series Star Trek: The Next Generation. The USS Enterprise NCC-1701-D was the Federation flagship under the command of Captain Jean-Luc Picard (Patrick Stewart), as he and his crew explored the far reaches of the galaxy. This replica was custom-built by a talented and accredited model maker working in the film industry.

This large scale model is hand-painted to match the original's details as closely as possible. It illuminates when powered, including light-up engines and windows. There are three metal wire loops on the top of the craft, allowing it to be hung. Dimensions: 201 cm x 148 cm x 39 cm (79 1/4" x 58 1/4" x 15 1/4")

Contains electronics; see electronics notice in the Buyer's Guide.

Special shipping required; see special shipping notice in the Buyer's Guide.

Estimate. £6,000 - 8,000



Top Detail



Case Detail

351
 Light-Up TR-590 Medical Tricorder X Ω
Star Trek: Voyager (T.V. Series, 1995 - 2001)

A light-up TR-590 medical tricorder X from the sci-fi series Star Trek: Voyager. Portable medical tricorders appeared throughout the series, often used by members of a Starfleet away team.

This silver-colour, clamshell-shaped tricorder is constructed of resin and plastic with a front that opens to reveal coloured decals on the interior featuring dummy buttons and medical information. Also included is a removable cylindrical metal wand detail. Opening the tricorder activates a series of inset AAA battery-powered lights, and pressing a button on its side activates the wand's 1.5v battery-powered lights. The tricorder comes in a black holster with a pair of clips. It exhibits some paint chipping and separation of several of the decals. Dimensions: 17.75 cm x 7.75 cm x 4 cm (4" x 3" x 1.5")

Contains electronic components; see notice in the Buyer's Guide.

Estimate. £8,000 - 12,000



352
 Light-Up Compression Phaser Rifle Ω
Star Trek: Voyager (T.V. Series, 1995 - 2001)

A light-up compression phaser rifle from the sci-fi series Star Trek: Voyager. USS Voyager crew used compression phaser rifles throughout the series.

This futuristic rifle is constructed from resin and machined aluminium painted silver-colour and black with red ribbing on the two-pronged split-emitter and acrylic panels inset on top. One AA battery-powered light hand-marked "C" on the interior and concealed behind the backmost panel illuminates via a front button. Metal wiring for securing straps and fastening strips are affixed below dual grips. The rifle exhibits visible signs of production use and wear, with chips and paint scuffing throughout the resin, and has been sympathetically repaired following fracturing to the emitter. Dimensions: 91.5 cm x 28 cm x 20.5 cm (36" x 11" x 8")

Contains electronic components; see notice in the Buyer's Guide.

Estimate. £3,000 - 5,000



353
 Yoda's Jedi Robes Ω
Star Wars:
The Phantom Menace (1999)

Yoda's Jedi robes from George Lucas' Star Wars: The Phantom Menace. Yoda wore his robes throughout the film, including the scenes where he sat with the Jedi Council, gave advice to Obi-Wan (Ewan McGregor) and attended Qui-Gon Jinn's (Liam Neeson) funeral. Yoda was originally a puppet for The Phantom Menace, before being rendered entirely in CGI for the following two films in the prequel trilogy. Later releases of The Phantom Menace featured a fully CG version of the character. The puppet Yoda also appeared in his robes on page 9 of Star Wars Episode 1: The Visual Dictionary, and in the behind-the-scenes documentary which accompanied the DVD release. This costume was saved after production when the original puppet was discarded. It is a significant piece, as costumes from the prequel trilogy are extremely rare and hard to find.

The costume was designed to be in keeping with the clothes Yoda wore in The Empire Strikes Back and Return of the Jedi, which themselves were an extension of the older Obi-Wan Kenobi's (Alec Guinness) desert robes. The style of costume later became synonymous with the Jedi Order as a whole.

The costume consists of a beige woollen hooded robe and a brown woollen tunic. Both feature remnants of green rubber in places, and there are small patches of aged brown foam stuck to the robe. Both garments feature labels from JAK Productions Ltd, on which "Yoda" is handwritten. The costume is displayed on a custom-made poseable Yoda-shaped display featuring a model of Yoda's head, which is a cast of the final approved design sculpt for the film. The original design sculpt was undertaken by Gary Pollard and approved in person by George Lucas. Dimensions (display): 25 cm x 45 cm x 89 cm (9 3/4" x 13 1/2" x 35")

Estimate. £40,000 - 60,000



89 cm (35")





ScreenProd / Photononstop
/ Alamy Stock Photo

354
 Padmé Amidala's (Natalie Portman)
 Hero Blaster M
Star Wars:
The Phantom Menace (1999)

Padmé Amidala's (Natalie Portman) hero blaster from George Lucas' Star Wars: The Phantom Menace. Padmé used her blaster during the assault on Theed Palace. It also appears on page 29 of Star Wars Episode I: The Visual Dictionary, in both its long-barrel and short-barrel form.

The blaster features a resin body with vacuum metalised plating, an aluminium barrel and nozzle, and a wooden handle. The blaster has some wear from use, most notably some red staining on the top of the body, and a couple of sections where the plating has come away, revealing the black resin beneath. Dimensions: 33 cm x 4 cm x 13 cm (13" x 1 1/2" x 5")

Estimate. £40,000 - 60,000



ScreenProd / Photononstop
/ Alamy Stock Photo



355
 Qui-Gon Jinn's (Liam Neeson)
 Hero Lightweight Lightsaber M
Star Wars:
The Phantom Menace (1999)

Qui-Gon Jinn's (Liam Neeson) lightweight hero lightsaber from George Lucas' Star Wars: The Phantom Menace. Jedi Master Qui-Gon carried his lightsaber throughout the film, and Obi-Wan (Ewan McGregor) later used it to cut Darth Maul (Ray Park) in half. It also features on page 12 of the book Star Wars Episode I: The Visual Dictionary.

Many iterations of lightsabers were designed for The Phantom Menace under the direction of design director Doug Chiang, with each Jedi having a uniquely crafted lightsaber designed to reflect their personality. Neeson personally picked this hilt design for his character.

The lightsaber hilt is constructed primarily from resin. It has a steel blade emitter (a feature unique to the film's lightsaber props) and features ribbed detailing running from the emitter down to the base, creating a grip. The hilt is finished in a combination of black and faux-silver paint, and a red static activator switch adorns one side. It also features a swivelling, removable clip, allowing it to be hooked onto a belt. There are small patches of paint wear exposing the resin beneath, a small chip on the red switch, and overall the lightsaber displays some light scratching and scuffing from production use. Dimensions: 28.5 cm x 5.5 cm x 4.5 cm (11 1/4" x 2 1/4" x 1 3/4")

Estimate. £30,000 - 50,000





356
Mace Windu's (Samuel L. Jackson) Hero Lightweight Lightsaber **Star Wars: The Phantom Menace (1999)**

Mace Windu's (Samuel L. Jackson) lightweight hero lightsaber from George Lucas' Star Wars: The Phantom Menace. This style of hilt is worn by Windu in Star Wars Episode I: The Visual Dictionary and can also be spotted in behind-the-scenes footage of several lightsabers in a transport box. It also features in Attack of the Clones, and is seen being held in promotional stills by Plo Koon (Matt Sloan) and Luminara Unduli (Mary Oyaya). For Attack of the Clones and Revenge of the Sith, Windu's lightsaber was redesigned with Jackson's input to make it more distinctive.

This lightsaber hilt features a resin-and-metal handgrip finished in silver-coloured paint, with a tapered pommel cap inset. The lightsaber features a black activator switch and a red blade-length adjuster button, as well as a swivelling clip allowing it to be hooked onto a belt. The clip can be removed. There are small patches of paint wear exposing the resin beneath, and the lightsaber displays some light scratching and scuffing from production use. Dimensions: 28 cm x 6.5 cm x 7 cm (11" x 2 1/2" x 2 3/4")

Estimate. £15,000 - 25,000



Star Wars: Episode I - The Visual Dictionary
by David West Reynolds, published by DK.

35 cm (13.75")



357
Yoda's Master Reference Gimer Stick **Star Wars: The Phantom Menace (1999)**

An unpainted production cast of Yoda's master reference gimer stick from George Lucas' Star Wars: The Phantom Menace. Yoda walked with his stick while talking with Obi-Wan Kenobi (Ewan McGregor) about training young Anakin Skywalker (Jake Lloyd). In Star Wars lore, gimer sticks were a source of nutrients if chewed and helped aid in meditation. This unpainted resin prop was created during the production and has been cast to resemble knotted wood. Dimensions: 10 cm x 3.5 cm x 35 cm (4" x 1 1/2" x 13 3/4")

Estimate. £3,000 - 5,000

33 cm (13")

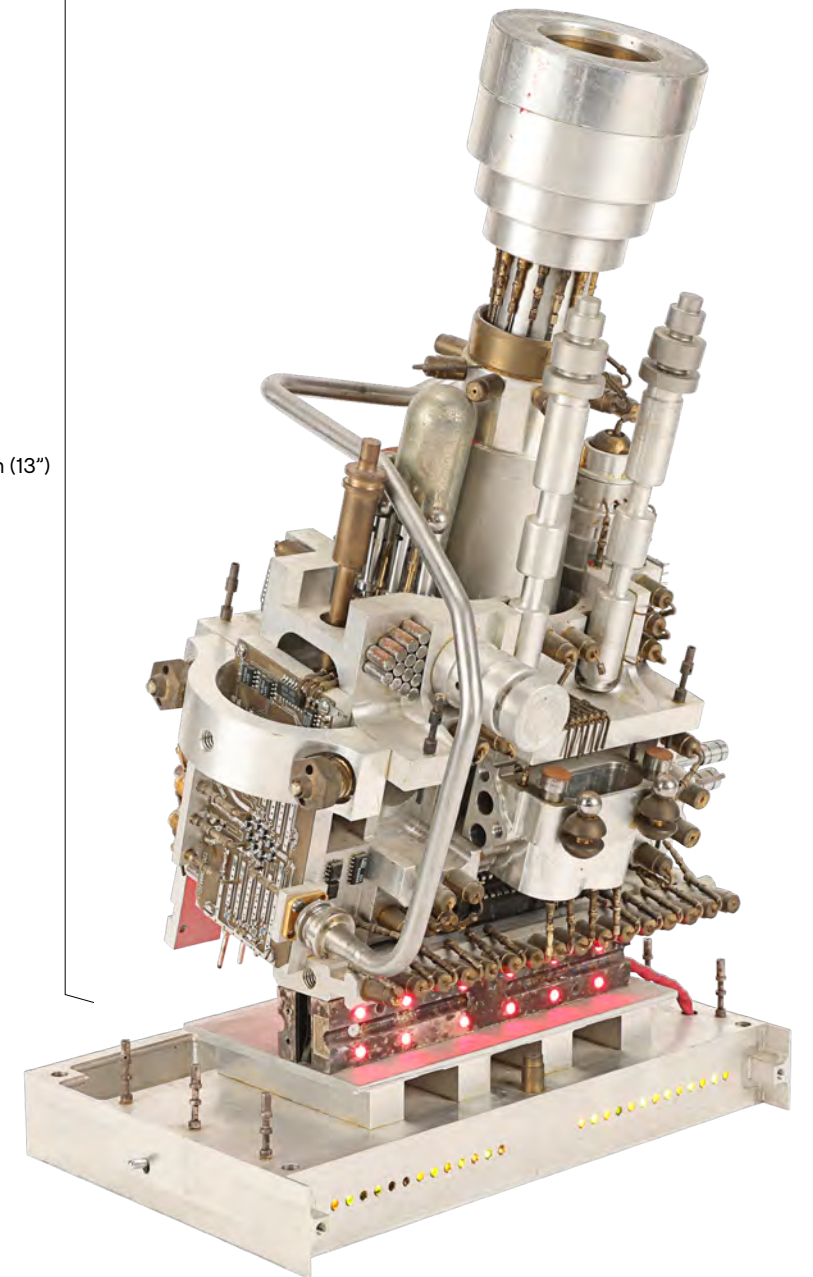

358
Light-up Meson Taloscope **Star Wars: The Phantom Menace (1999)**

A light-up meson taloscope from George Lucas' Star Wars: The Phantom Menace. Obi-Wan Kenobi (Ewan McGregor) used one of the Naboo Royal Starship's taloscopes to measure Anakin's (Jake Lloyd) midi-chlorian count, and two starship crew members used another taloscope as Obi-Wan spoke with Qui-Gon Jinn (Liam Neeson) via comlink.

The taloscope is made primarily of aluminium with brass and copper detailings. It is powered by a 9V battery and flashing red, green and orange lights illuminate when a switch on the side is activated. It has some tarnishing, and remnants of a red waxy substance. Dimensions: 13 cm x 18.5 cm x 33 cm (5" x 7 1/4" x 13")

Contains electronics; see electronics notice in the Buyer's Guide.

Estimate. £3,000 - 5,000

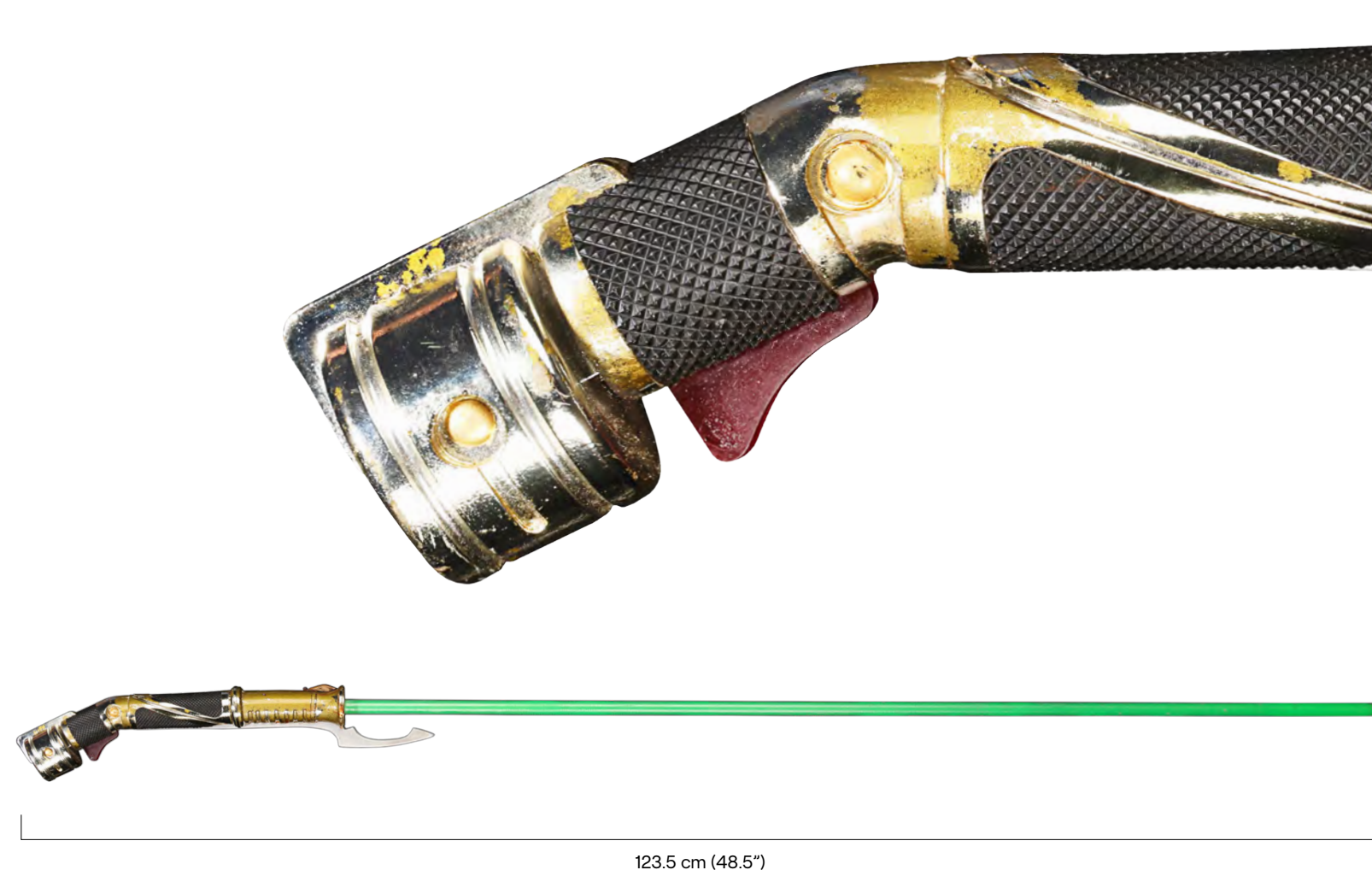

123.5 cm (48.5")

359
 Count Dooku's (Christopher Lee) Stunt Lightsaber with SFX Blade
Star Wars: Revenge Of The Sith (2005)

Count Dooku's (Christopher Lee) stunt lightsaber from George Lucas' Star Wars: Revenge of the Sith. Sith Lord Dooku wielded his lightsaber to fight the Jedi, and Anakin used Dooku's own lightsaber to behead him.

This lightsaber, made for sequences where Dooku fought the Jedi, comprises a carbon fibre SFX "blade" painted green and wrapped in a clear plastic sheath, and, separately, a resin handgrip inset plated silver with a steel rod, with gold and black painted detailing to simulate a textured metallic finish. The blade screws into the hilt and can be removed; this allowed damaged blades to be replaced during filming. The blade has "Green Good" handwritten on the section which screws into the hilt. The handgrip has some wear from age and use. Most notably, the metallic paints have worn away, revealing the gold-coloured resin beneath. Dimensions: 123.5 cm x 4 cm x 6 cm (48 1/2" x 1 1/2" x 2 1/4")

Estimate. £20,000 - 30,000

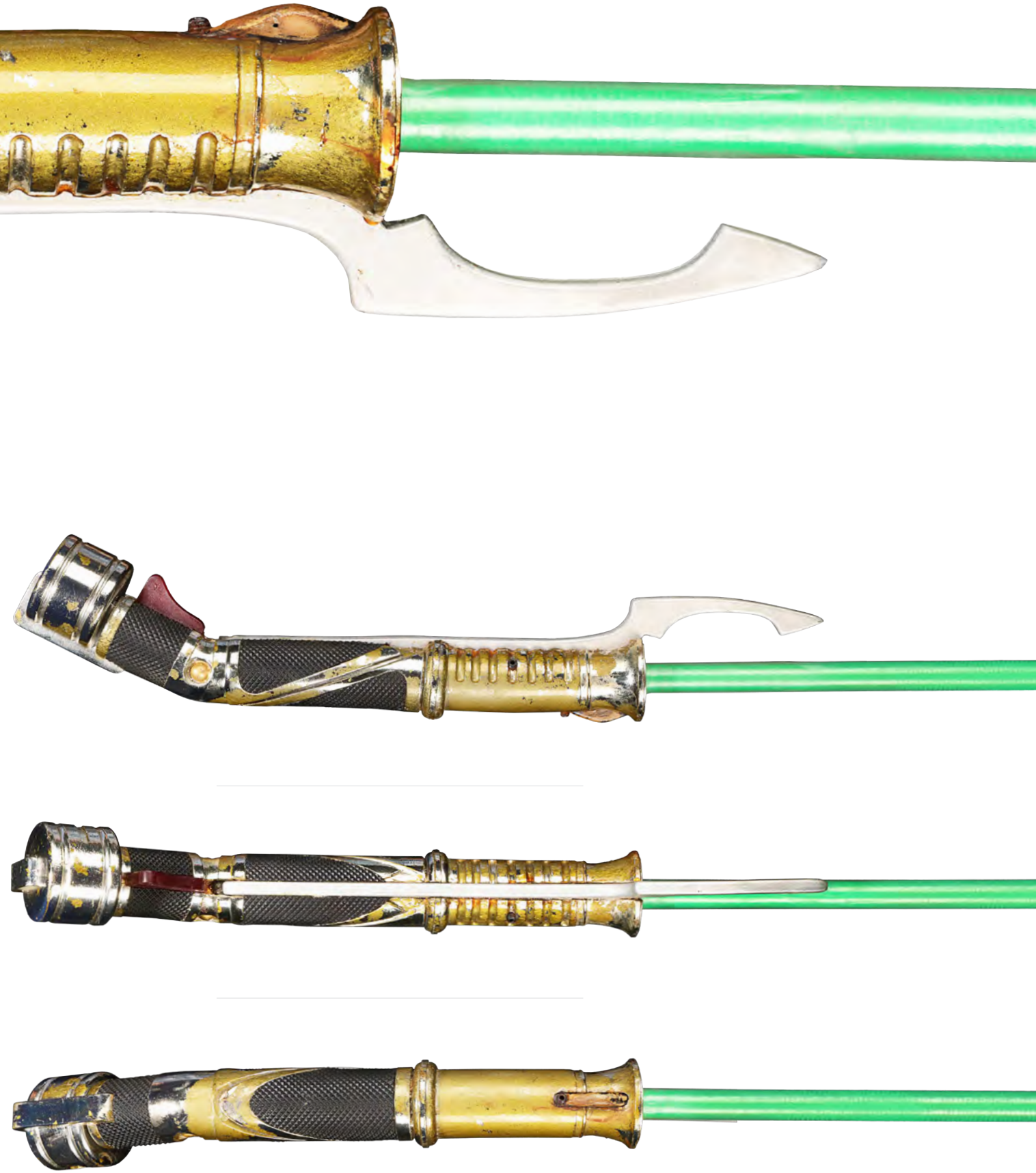
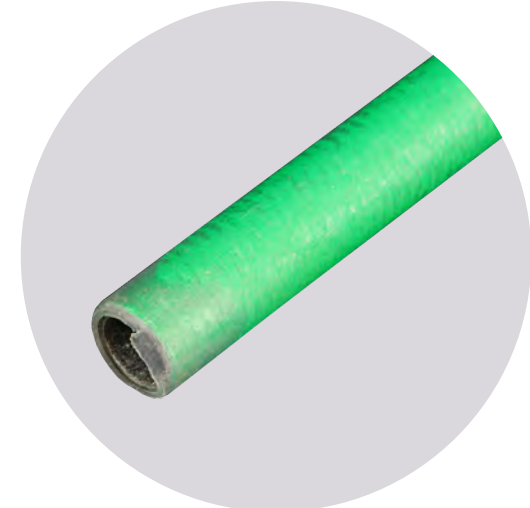



123.5 cm (48.5")

360
Mace Windu (Samuel L Jackson) SFX "Spinning" Lightsaber 
Star Wars: Attack Of The Clones (2002)

Mace Windu's (Samuel L. Jackson) SFX "spinning" lightsaber from George Lucas' Star Wars: Attack of the Clones. Jedi Master Windu wielded his distinctive amethyst lightsaber in battle throughout the film, including during his battle with Jango Fett (Temuera Morrison) and the Separatist Droid Army.

Jackson requested that George Lucas produce a purple lightsaber so Windu could stand out. Despite initial reluctance, Lucas agreed.

This lot consists of a lightsaber with a wrist attachment so Windu would rapidly spin the lightsaber in duelling sequences. It features an aluminium "blade" tube painted orange affixed to a resin and black rubber handgrip with painted gold- and silver-colour accents. The hilt features a self-fastening wrist closure attached to a bolt and washer on a bearing to facilitate the spinning effect without letting go of the weapon. This lot exhibits scratching in the aluminium and paint, and mild chipping.

Dimensions: 123.25 cm x 6.5 cm x 6.5 cm (48.5" x 2.5" x 2.5")

Estimate. £20,000 - 30,000



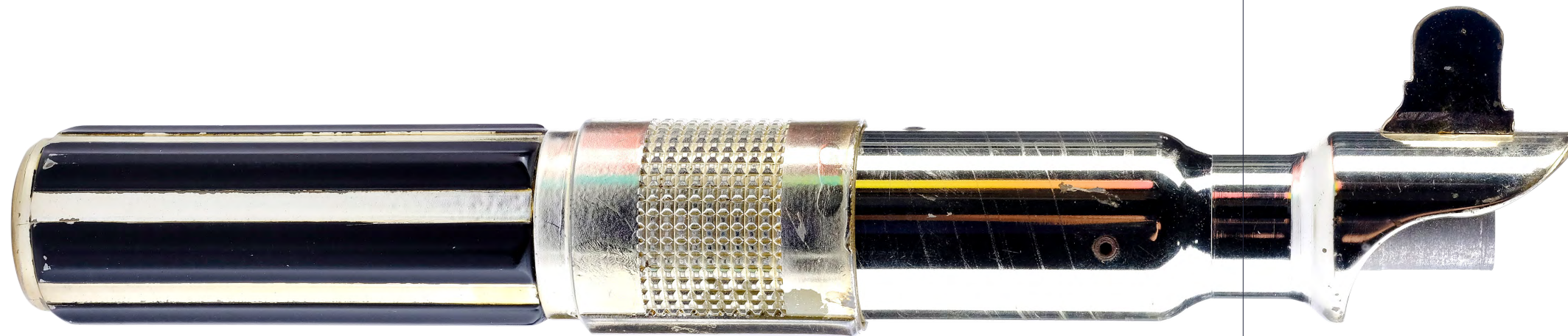

123.25 cm (48.5")



361
Anakin Skywalker's (Hayden Christensen) Bladed Duelling Lightsaber Ω
Star Wars: Revenge Of The Sith (2005)

Anakin Skywalker's (Hayden Christensen) bladed duelling lightsaber from George Lucas' Star Wars: Revenge of the Sith. After his first lightsaber was destroyed during the Battle of Geonosis in Star Wars: Attack of the Clones, Anakin wielded his newly-built lightsaber throughout the film, including during his climactic duel with Obi-Wan Kenobi (Ewan McGregor) on the fiery surface of Mustafar.

Anakin's second lightsaber played a pivotal role in the Skywalker storyline. After the duel on Mustafar, Obi-Wan (Alec Guinness) passed it to Luke Skywalker (Mark Hamill) in Star Wars: A New Hope before it appeared again in the sequel trilogy, thereby connecting the nine-film saga.

This lightsaber, a duelling version, was constructed specifically for the film and features a different design to Anakin's first lightsaber. While similar to the hero version, this piece lacks buttons or knobs and features a lowered neck area near the emitter in order for the actor to handle and spin the weapon during action sequences. Its cast resin handle is constructed around an aluminium sleeve into which the carbon fibre blade is inserted, enabling the actors to duel onset. The handle features a chrome-plated finish with grips painted black, as well as a threaded rod securing the upper and lower sections together at the blade's base.

The blade itself is painted orange with a clear plastic sheath to prevent blade chips from causing injuries, all of which was digitally replaced with a glowing blue blade in post-production. This lightsaber exhibits scuffs and scratches throughout the handle, most visibly on the chrome finish, as well as small tears to the sheath, grime, and scratched-off paint on the blade. Dimensions: 123.25 cm x 4.5 cm x 4.5 cm (48.5" x 1.75" x 1.75")

Estimate. £30,000 - 50,000



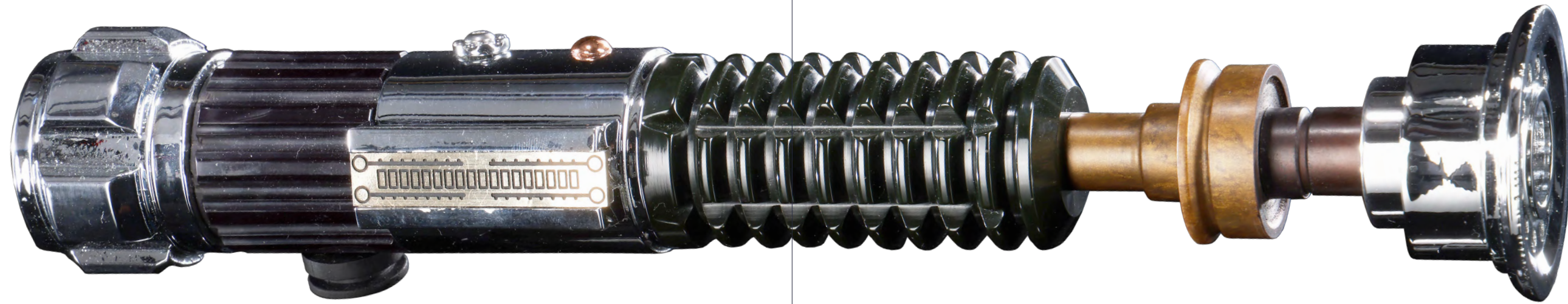

362
Obi-Wan Kenobi's (Ewan McGregor)
Hero Lightweight Lightsaber Ω
Star Wars: Revenge Of The Sith (2005)

Obi-Wan Kenobi's (Ewan McGregor) hero lightweight lightsaber from George Lucas' Star Wars: Revenge of the Sith. Jedi Master Obi-Wan wielded his signature blue lightsaber throughout the film, including during his fateful duel with Anakin Skywalker (Hayden Christensen) on the fiery surface of Mustafar.

This hilt was specifically constructed for the third prequel film and is a different design to the lightsaber wielded by Obi-Wan in the prior two Star Wars episodes. Like Anakin Skywalker's lightsaber, this lightsaber design links directly to Star Wars: A New Hope, where Alec Guinness appeared with a similar weapon as the older Kenobi. It is therefore one of the most iconic lightsaber designs in the Star Wars saga. Hero lightsaber hilts were made to be carried by the actors on their belts and in shots where the blades were not ignited.

This hero hilt is made of plastic-cast components. Three sections are chrome-plated, with a gold-coloured component above the grip and a thin copper-coloured section beneath the emitter that are both made of plastic coloured to look like metal. The lightsaber shows only minor wear from production use and age. It is accompanied by six printed photographs of the lightsaber behind the scenes and during the production process.

Dimensions: 28.5 cm x 5 cm x 5 cm (11 1/4" x 2" x 2")

Estimate. £70,000 - 100,000



Lucasfilm/Fox/Kobal /Shutterstock





Photo 12 / Alamy Stock Photo



363
Darth Vader's (Dave Prowse) Screen-matched Gloves
Star Wars: A New Hope (1977)

Darth Vader's (Dave Prowse) screen-matched gloves from George Lucas' Star Wars: A New Hope. Darth Vader wore his gloves as part of his iconic costume throughout the film. It is believed that only a single Darth Vader costume was used for the filming of A New Hope, and that costume was subsequently worn by performer Bryce "Kermit" Eller at numerous marketing and public promotional events following the release of the film, including charity events, shopping mall appearances and the 1978 Academy Awards®. Eller also played Vader in a Star Wars musical parody on the Donny & Marie show and stepped into wet cement at a footprint ceremony in front of Mann's Chinese Theatre in 1977, all of which were done with the original film-used costume.

The placement of the creases in the leather match these gloves to scenes where the gloves are seen well in the film, including when Vader throttled Captain Antilles (Peter Geddis), when Vader and Leia (Carrie Fisher) first come face to face after her capture, and during close ups while Vader piloted a TIE fighter. They can also be matched to promotional photos of Eller in the costume for marketing purposes.

These mid-length gloves are made of black leather, and feature horizontally quilted stripes running up to the knuckle on the top side. They are presented on wood-and-foam model hands covered in black fabric, and accompanied by a still of Darth Vader, with Prowse's autograph in black pen. The photograph is presented in a clear acrylic display frame. As it is believed that only a single Darth Vader costume was used for filming, these first-film leather gloves are an extremely significant artefact from the origin of cinema's most-famous villain. They are also one of only very few components still in existence from the first-ever Darth Vader costume. The lot exhibits wear from production and promotional use, including loose threads, tears in the fingers (some of which have been carefully and sympathetically restored) and discolouration on the inside arm of the right glove. Dimensions (each glove): 33.5 cm x 15.5 cm x 7 cm (13 1/4" x 6 1/4" x 2 3/4"); (photo display): 8.5 cm x 30 cm x 21.5 cm (3 1/4" x 11 3/4" x 8 1/2")

Additional Provenance: Previously sold at Bonhams in 2019.

Estimate. £150,000 - 250,000



Photo 12 / Alamy Stock Photo





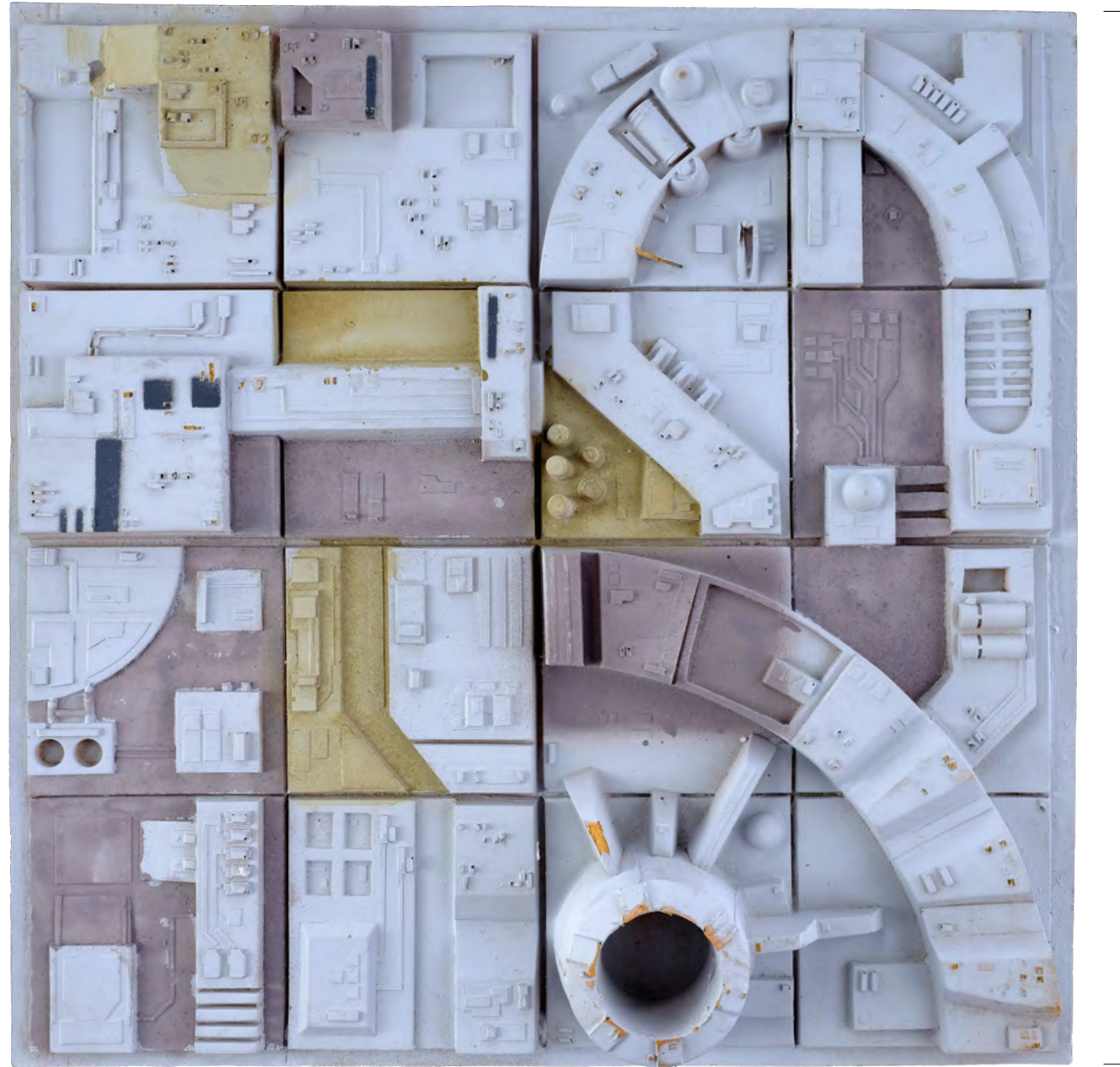

30.48 cm (12")



364
 High-Altitude Death Star Surface Model Ω
Star Wars: A New Hope (1977)

A high-altitude Death Star surface model from George Lucas' Star Wars: A New Hope. Rebel fighters flew close to the surface of the Death Star during their final assault on the fearsome vessel.

Designed and constructed by Industrial Light & Magic's (ILM) model miniature department for high-altitude shots of the massive miniature set of the Death Star's unique surface, this model miniature is made up of 16 different sections of biscuit foam decorated with cast greebles and finished in two shades of grey paint with black accents. It exhibits chipping and staining throughout from use and age. Dimensions: 30.5 cm x 30.5 cm x 7.75 cm (12" x 12" x 3")

Estimate. £10,000 - 15,000

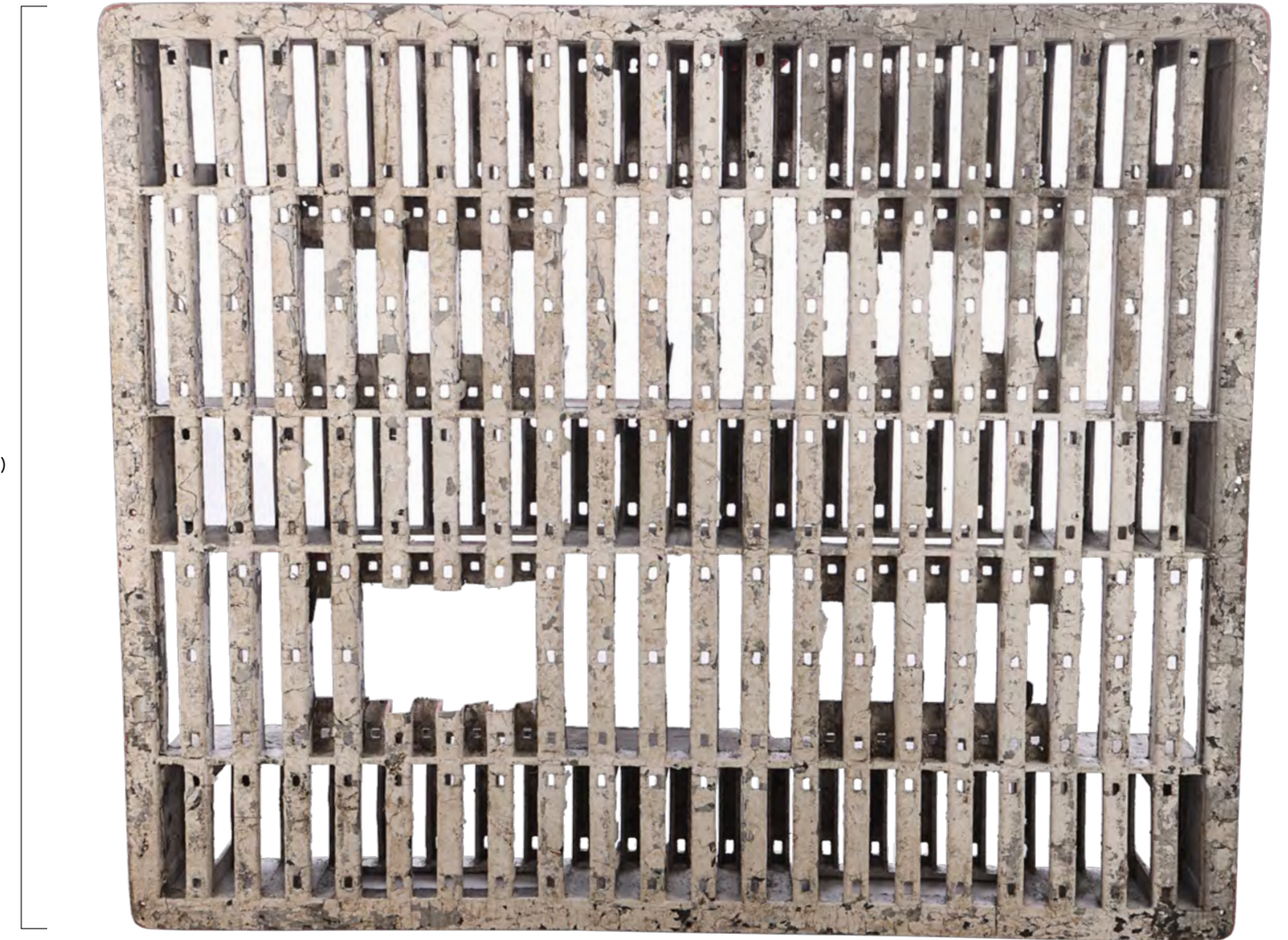

98 cm (38.5")



365
 Millennium Falcon Floor Panel/Death Star Ceiling Panel Ω
Star Wars: A New Hope (1977)

A Millennium Falcon floor panel, also used as a Death Star ceiling panel, from George Lucas' Star Wars: A New Hope. The floor of the Millennium Falcon featured grate-like panels in multiple scenes, such as the one where Obi-Wan Kenobi (Alec Guinness) trained Luke Skywalker (Mark Hamill) in the ways of the Force. These panels also formed the ceiling of the Death Star, and were seen when an IT-O interrogation droid was used by Darth Vader (David Prowse) on Princess Leia (Carrie Fisher).

The heavy-duty plastic panel is painted silver, though some of the paint has flaked away over time, exposing orange paint beneath. The lot also displays marks from age and production use. Dimensions: 119 cm x 98 cm x 14 cm (46 3/4" x 38 1/2" x 5 1/2")

Special shipping required; see special shipping notice in the Buyer's Guide.

Estimate. £8,000 - 12,000

CHARLES LIPPINCOTT STAR WARS COLLECTION & ARCHIVE

Lots in this section of the auction come from the collection of Charles "Charley" Lippincott. Lippincott is considered among the foremost marketing and merchandising experts in the history of fantasy and science-fiction. After an early start in traditional Hollywood publicity, his career exploded when college friend George Lucas hired him as Lucasfilm's VP of Advertising, Publicity, Promotion & Merchandising, a role he used to create arguably the most successful - and bombastic - marketing campaign ever for Lucas' 1977 blockbuster Star Wars. Lippincott subsequently masterminded the publicity strategies for such era-defining properties as Ridley Scott's Alien and Mike Hodges' Flash Gordon. The popularity of these projects further propelled him into the top ranks of film executives, leading him to produce Danny Cannon's cult classic Judge Dredd.

While Charley Lippincott passed away in 2020, his personal collection of rare unseen production and marketing materials reflects a legacy of influence on some of cinema's most memorable titles. All auction registrants will also be entered into a random giveaway drawing to win a T-shirt or brochure produced by Lippincott for the 2016 convention MidAmeriCon 2 ("MAC II") whichre-united Gary Kurtz, Alan Dean Foster, Marc Pevers, and Gary Kurtz. The giveaway is made possible by Lippincott's estate.

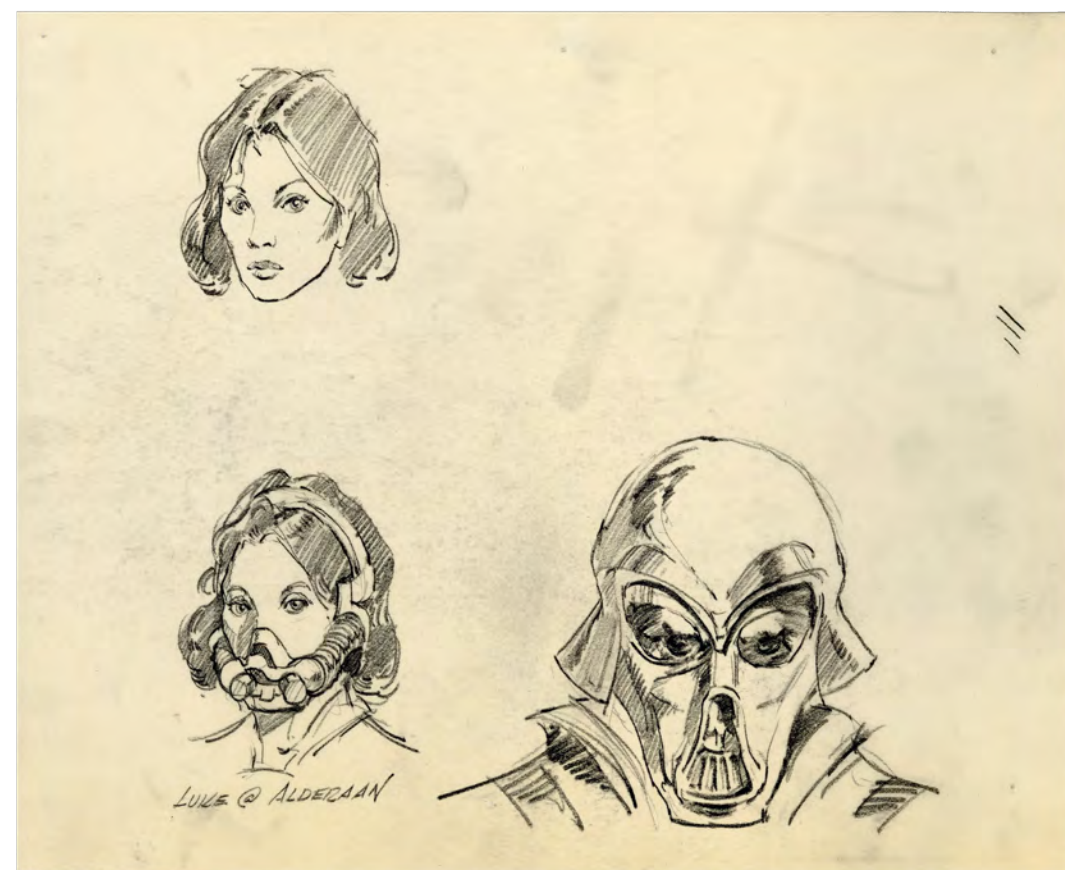

366
Charles Lippincott Collection:
Hand-Drawn Alex Tavoularis
Female Luke and Darth Vader
Concept Sketches Ω
Star Wars: A New Hope (1977)

Concept sketches of a female Luke Skywalker and Darth Vader hand-drawn by Alex Tavoularis during early pre-production on George Lucas' Star Wars: A New Hope. In his second draft of the script from March 1975, Lucas changed Skywalker - then known as "Luke Starkiller" - to a female character. But in the following draft, he split the character into two - Luke and Princess Leia - suggesting that these rare sketches were completed by Tavoularis, an illustrator and industrial artist who created early concept storyboards, prior to the third draft.

Rendered in graphite on vellum, these three concept sketches - one of Luke wearing a face apparatus labelled "Luke at Alderaan"; one of a bare-faced female Luke; and one of Darth Vader - come from the collection of the film's advertising and publicity supervisor Charles "Charley" Lippincott. The vellum exhibits smudging, stray marks, and staining. Dimensions: 21.75 cm x 28 cm (8.5" x 11")

Sold without copyright; see notice in the Buyer's Guide.

Estimate. £6,000 - 8,000

367
Charles Lippincott Collection:
Hand-Drawn Alex Tavoularis
Rebel Guard Concept Sketch Ω
Star Wars: A New Hope (1977)

A concept sketch of Rebel guards hand-drawn by Alex Tavoularis for George Lucas' Star Wars: A New Hope. Tavoularis, an illustrator and industrial artist, created this concept sketch of guards scanning the Millennium Falcon upon its arrival to the Rebel base on Yavin IV in early pre-production.

This sketch comes from the collection of the film's advertising and publicity supervisor Charles "Charley" Lippincott. It is rendered in graphite on heavyweight paper. The paper exhibits tearing along the edges, a missing top right corner, and pinholes throughout from hanging. Dimensions: 21.75 cm x 28 cm (8.5" x 11")

Sold without copyright; see notice in the Buyers Guide.

Estimate. £3,000 - 5,000

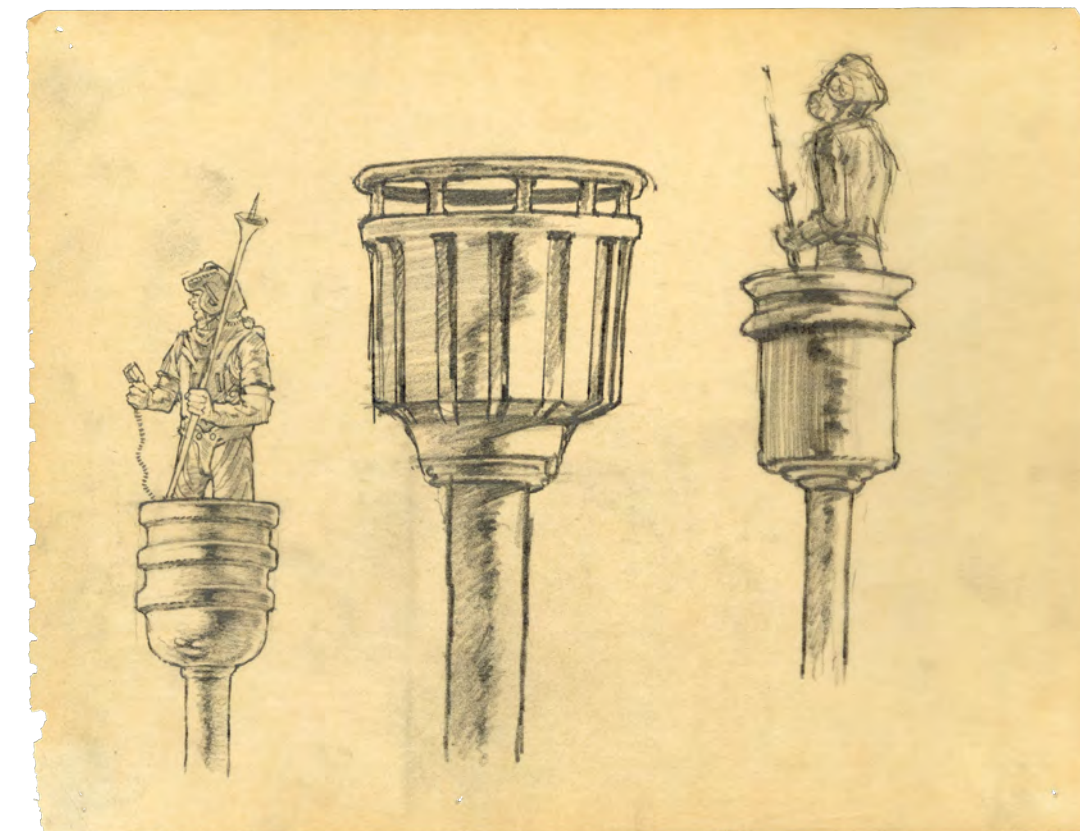

368
Charles Lippincott Collection:
Set of 58 Printed Ivor Beddoes
Lightsaber Duel and Stormtrooper
Attack Storyboards Ω
Star Wars: A New Hope (1977)

58 printed lightsaber duel and stormtrooper attack storyboards from the production of George Lucas' Star Wars: A New Hope. Originally drawn by Ivor Beddoes, a UK-based sketch artist and illustrator who did early work on the film, then copied by production for distribution to key department heads, these storyboards depict the sequences where stormtroopers attempted to destroy the Millennium Falcon and the fateful lightsaber duel between Obi-Wan Kenobi (Alec Guinness) and Darth Vader (David Prowse).

This set comes from the collection of the film's advertising and publicity supervisor Charles "Charley" Lippincott. Each storyboard is printed in black-and-white, and several feature notes regarding their respective sequences printed in the margins. The set exhibits ink smudging, some paper discoloration, and minor creasing throughout. Dimensions (each): 20.5 cm x 33 cm (8" x 13")

Estimate. £4,000 - 6,000



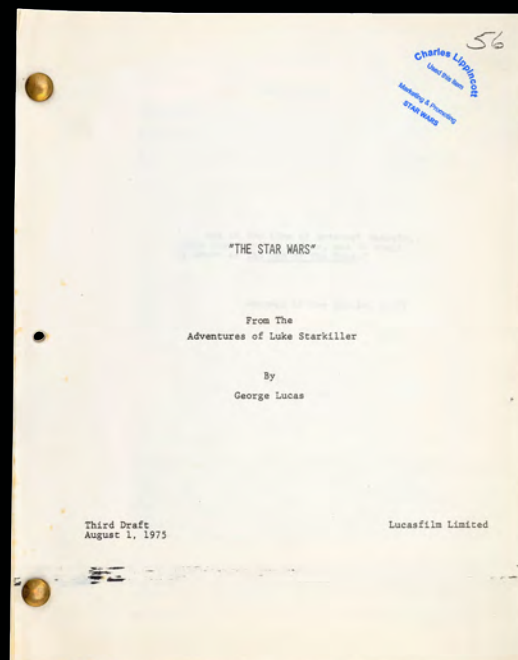

Third Draft
August 1, 1975

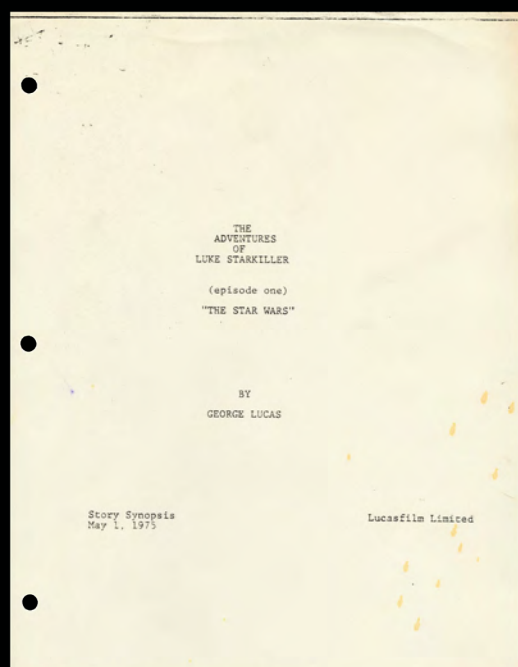
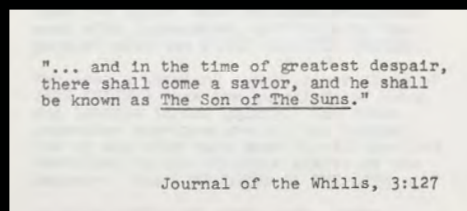
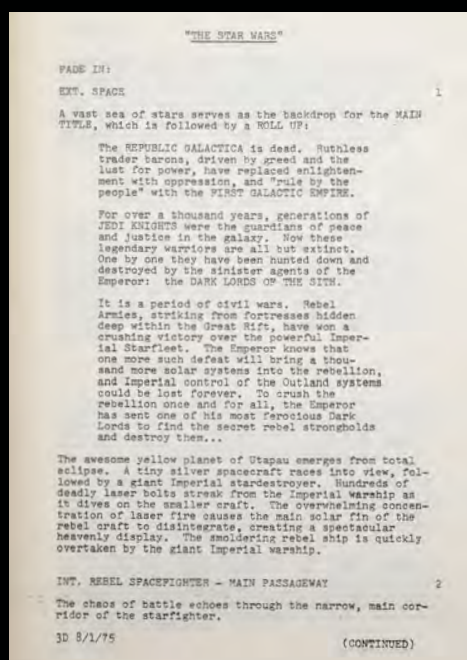

Story Synopsis
May 1, 1975

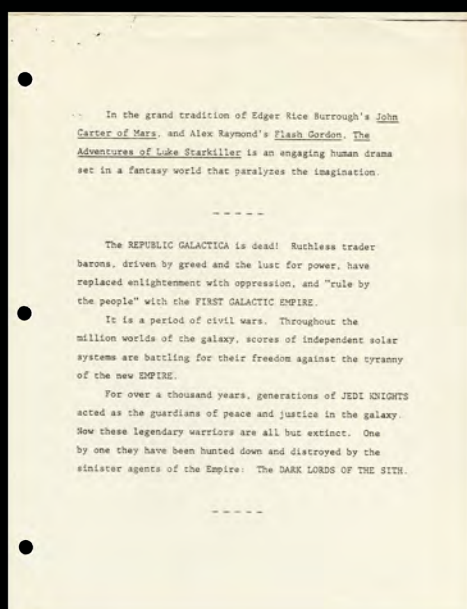

THE ADVENTURES OF LUKE STARKILLER (episode one) THE STAR WARS

Charles Lippincott Used this item Marketing & Promoting STAR WARS

369
Charles Lippincott Collection:
Bound Production-Used
Third Draft Script
Star Wars: A New Hope (1977)

A bound, production-used third draft script for George Lucas' Star Wars: A New Hope. The third draft was the first version to closely resemble the theatrically released film, but still included early character names and locations which would later be omitted or changed.

This 110-page, brass brad-bound script comes from the collection of the film's advertising and publicity supervisor Charles "Charley" Lippincott and features his stamp on the front cover. It also features the header "The Star Wars" From the Adventures of Luke Starkiller by George Lucas," the date "August 1, 1975," and the number "56." The script exhibits creasing and folding to some pages, edge wear, and stains on the cover from production use. Dimensions: 21.75 cm x 28 cm x 1.5 cm (8.5" x 11" x 0.5")

Estimate. £6,000 - 8,000

370
Charles Lippincott Collection:
"The Adventures of Luke Starkiller"
Story Synopsis
Star Wars: A New Hope (1977)

A story synopsis for "The Adventures of Luke Starkiller," an early title for George Lucas' Star Wars: A New Hope. Early versions of Lucas' screenplay featured additional variations on the title, including "Adventures of the Starkiller."

This brass brad-bound, six-page synopsis comes from the collection of the film's advertising and publicity supervisor Charles "Charley" Lippincott. The cover is dated "May 1, 1975" with the subheader "The Adventures of Luke Starkiller." Page 2 describes the story as "an engaging human drama set in a fantasy world that paralyzes [sic] the imagination." The synopsis is hole-punched and the cover exhibits yellow staining. Dimensions: 21.75 cm x 28 cm (8.5" x 11")

Estimate. £1,500 - 2,500



68.75 cm (27")

371
Charles Lippincott Collection:
TEAC and TASCAM
One-Sheet Proof
Star Wars: A New Hope (1977)

A proof for an unreleased TEAC and TASCAM one-sheet from the promotion of George Lucas' Star Wars: A New Hope. TEAC and TASCAM's equipment was used to record R2-D2's (Kenny Baker) droid beeps, as well as much of the special dialogue and sound effects in the film.

One-sheets based on the advance style "B" posters were later created by Gore Graphics as part of a promotional package designed by Lucas and TASCAM to highlight the groundbreaking sound effects. When the promotional package was axed, nearly all of the one-sheets were destroyed by Gore Graphics. Only around three are thought to have survived, including this proof, making it among the rarest pieces in Star Wars fandom. Instances of this poster being offered for sale are exceptionally rare.

This original, blue-and-white proof features the tagline "A long time ago in a galaxy far, far away... TEAC and TASCAM were there." comes from the collection of the film's advertising and publicity supervisor Charles "Charley" Lippincott. Also included is a hand-marked Gore Graphics proof sheet numbered "9097" and dated "9/13" for customer "TEAC." The poster's borders are greying from age, and it exhibits crease lines and light tearing on the edges from being rolled. As this is the proof and different paper was ultimately used, the poster also exhibits colour variances from the finished poster. Dimensions: 68.75 cm x 104.25 cm (27" x 41")

Estimate. £4,000 - 6,000



372
 Charles Lippincott Collection:
 American Marketing Association
 Convention Poster Ω
Star Wars: A New Hope (1977)

An American Marketing Association convention poster from the promotion of George Lucas' Star Wars: A New Hope. The American Marketing Association produced an extremely limited number of posters featuring original art to commemorate 20th Century Fox's Director of Business Affairs, International Distribution, Marc Pevens', speech at its San Diego, California, conference on 22 September, 1977.

This rare, original full-colour glossy poster featuring the Death Star looming over key characters, including Obi-Wan Kenobi (Alec Guinness) with a white lightsaber, comes from the collection of the film's advertising and publicity supervisor Charles "Charley" Lippincott. The unique artwork created by artist Bob Watts specifically for the convention features one of the last official uses of the original "pointy W" Star Wars logo. Because this poster was only given away at one event in 1977, it is considered one of the rarest Star Wars commercial posters. It exhibits crease lines throughout from being rolled for storage. Dimensions: 58.5 cm x 45.75 cm (23" x 18")

Estimate. £4,000 - 6,000



45.75 cm (18")



373
 Charles Lippincott Collection:
 Hong Kong Poster with Style "C"
 Tom Chantrell Artwork Ω
Star Wars: A New Hope (1977)

A Hong Kong poster from the promotion of George Lucas' Star Wars: A New Hope. Featuring art based on Tom Chantrell's design for the U.S. style "C" one-sheets, posters of this style were distributed exclusively in Hong Kong territories, making them one of the scarcest international variants.

This rare, full-colour glossy poster comes from the collection of the film's advertising and publicity supervisor Charles "Charley" Lippincott. It features a montage of key characters against the looming Death Star, Cantonese text in four different colours, and black borders. The poster exhibits fold lines and smudging in the margins. Dimensions: 54.75 cm x 78.75 cm (21.5" x 31")

Estimate. £3,000 - 5,000



374
 Charles Lippincott Collection:
 Israeli Poster Ω
Star Wars: A New Hope (1977)

An Israeli movie poster from the promotion of George Lucas' Star Wars: A New Hope. 20th Century Fox distributed Hebrew-language posters featuring a mashup of Tom Jung's style "A" artwork and motifs from the Brothers Hildebrandts' marketing artwork internationally in 1978. As few as 10 are thought to remain in existence.

This original poster comes from the collection of the film's advertising and publicity supervisor Charles "Charley" Lippincott. It features the tagline "View this space Western that is all 'fun'" in untranslated Hebrew at the top, as well as the A.D. Matalon logo and a blue bar for local cinemas to write in their showtimes added at the bottom. The poster exhibits small holes, fold lines, and stains along the margins from age and handling. It is linen-backed, but remains unrestored with no additional touch-ups. Dimensions (poster): 63.5 cm x 94 cm (25" x 37")

Estimate. £5,000 - 7,000

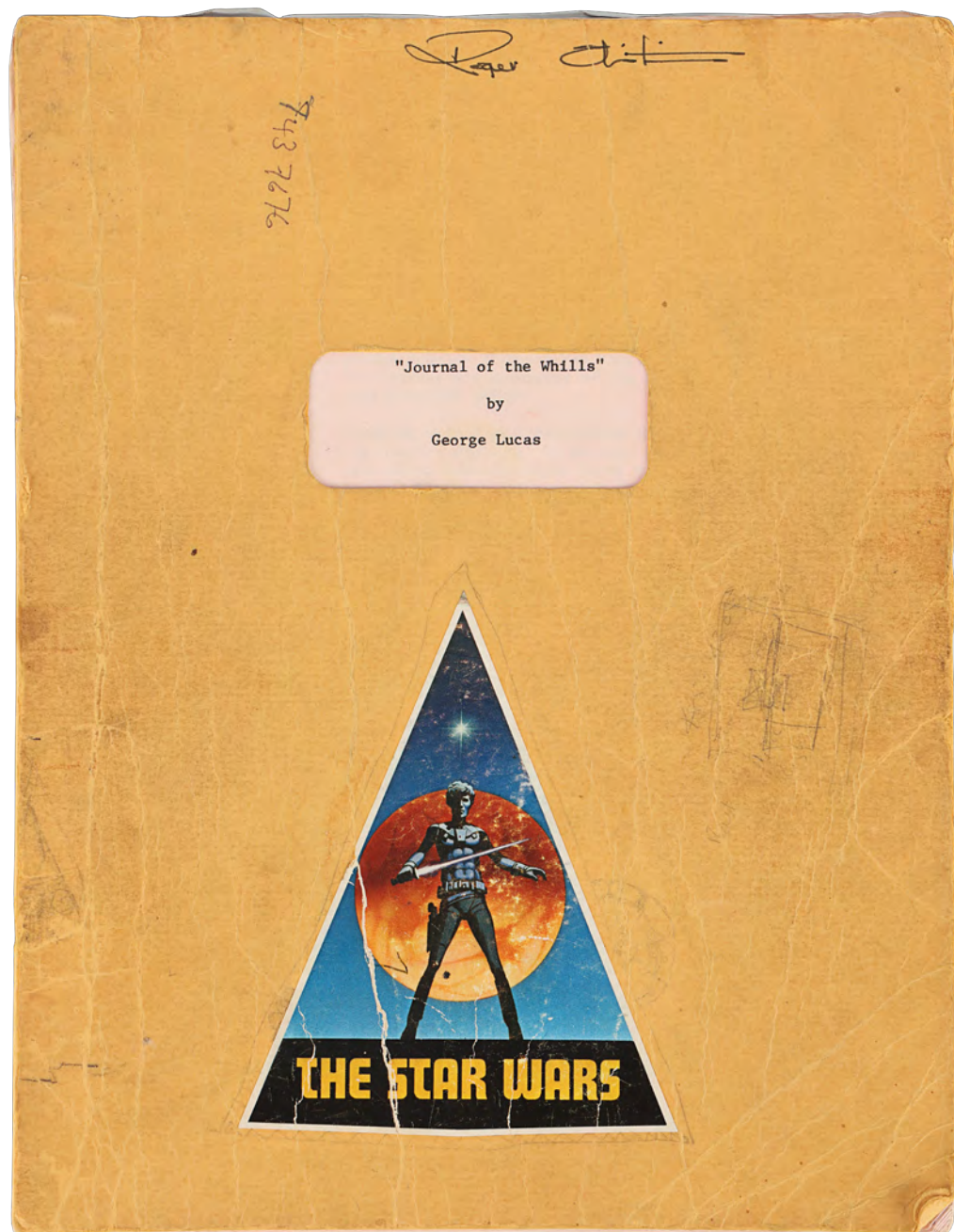

375
 Roger Christian's Revised Fourth-draft Script **Star Wars: A New Hope (1977)**

Roger Christian's revised fourth-draft script from the production of George Lucas' Star Wars: A New Hope. Christian won the Academy-Award® for Best Production Design for his work as the set decorator on the film.

The document comes bound in a yellow card cover featuring a triangular Ralph McQuarrie-designed "The Star Wars" sticker, with Christian's name handwritten near the top edge. The title page bears the original title "The Adventures of Luke Starkiller, as taken from the Journal of the Whills". Christian's name and the words "Set Decorator" are handwritten in red ink on the title page.

The 156-page script offers detailed insights into the creation of the first Star Wars film, and includes early character names and locations, many of which were omitted or changed by the time of filming. It is dated "March 15, 1976", and some pages display handwritten annotations relating to props. There are several sketches throughout the document, including a rough pencil doodle of an X-Wing on the front cover and one of the Death Star's tractor beam control unit, which Obi-Wan Kenobi (Alec Guinness) deactivated before his lightsaber duel with Darth Vader (David Prowse). The script exhibits visible marks and creasing on the front and back, with edge wear on the pages and corrosion on the metal binder clips. Dimensions: 28 cm x 22 cm x 2 cm (11" x 8 1/2" x 3/4")

Estimate. £12,000 - 16,000

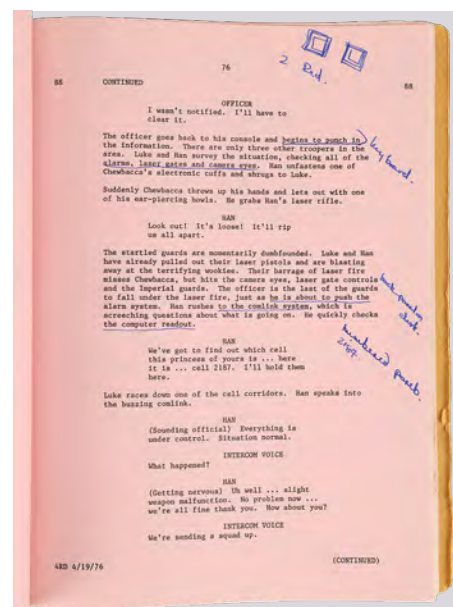
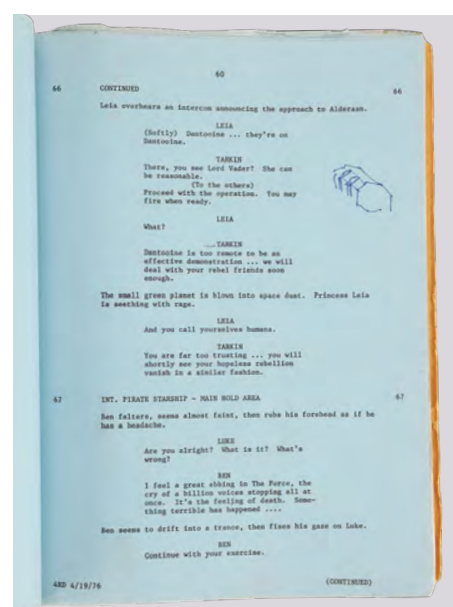

376
 Hand-drawn Ralph McQuarrie C-3PO Concept Sketch **Star Wars: A New Hope (1977)**

A concept sketch of C-3PO (Anthony Daniels) hand-drawn by Ralph McQuarrie for George Lucas' Star Wars: A New Hope. Protocol droid C-3PO (Anthony Daniels) accompanied Luke Skywalker (Mark Hamill) on his quest to rescue Princess Leia (Carrie Fisher) from the clutches of the Empire.

Production illustrator McQuarrie, who is credited alongside Lucas for the origins of "Threepio," created this sketch early in pre-production. McQuarrie based the droid's design on the robot Maria from Fritz Lang's classic Metropolis, although the character ultimately seen on screen was both more masculine and less human-looking.

This sketch depicting a rear view of C-3PO is rendered in graphite on tissue paper. The sketch is also featured on page 27 of the Abrams publication Star Wars Art: Ralph McQuarrie. The tissue is torn on the bottom left corner and exhibits crease lines throughout. Dimensions: 38.25 cm x 20.5 cm (15" x 8")

Sold without copyright; see notice in the Buyer's Guide.

Estimate. £8,000 - 12,000

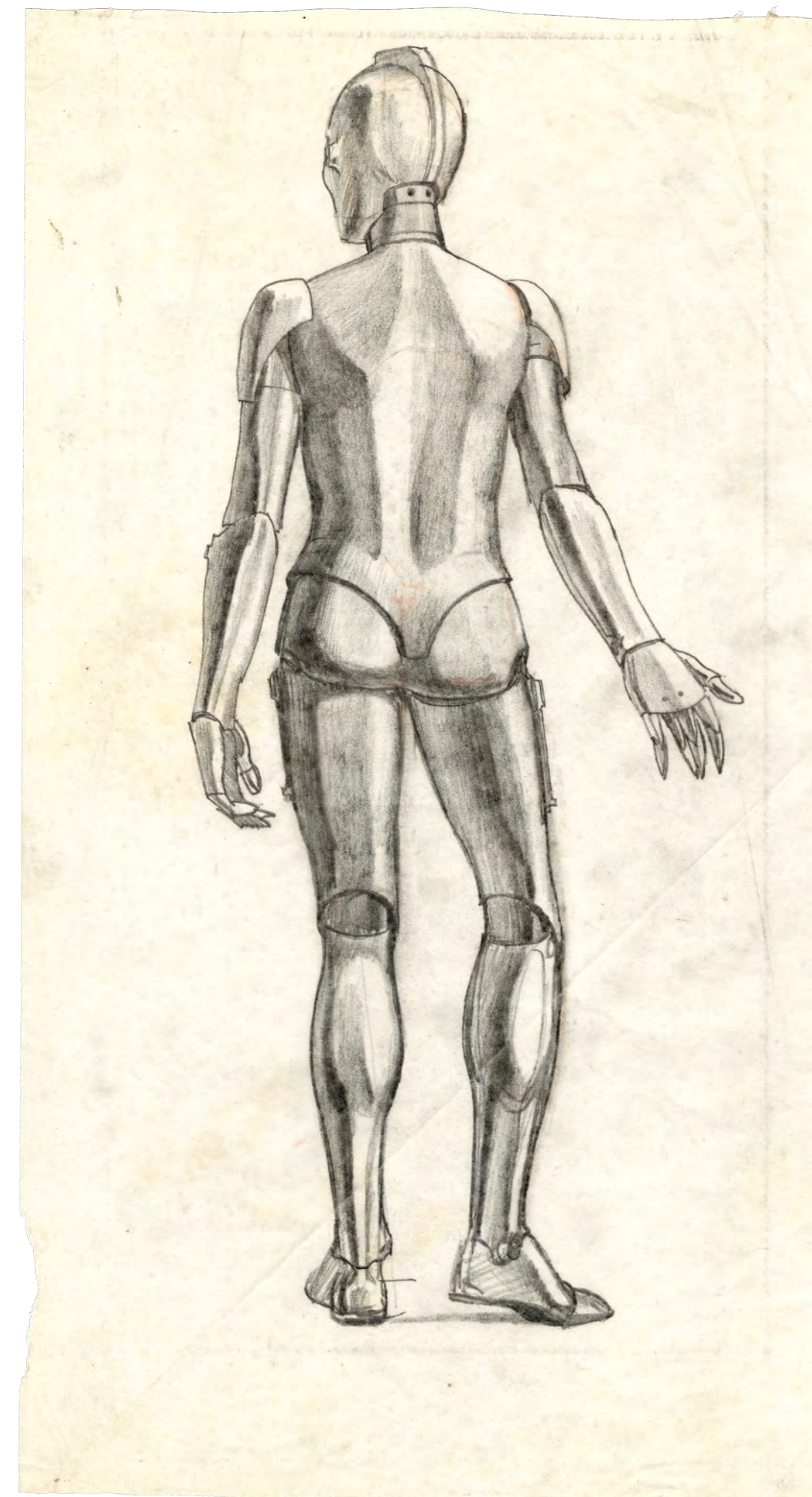

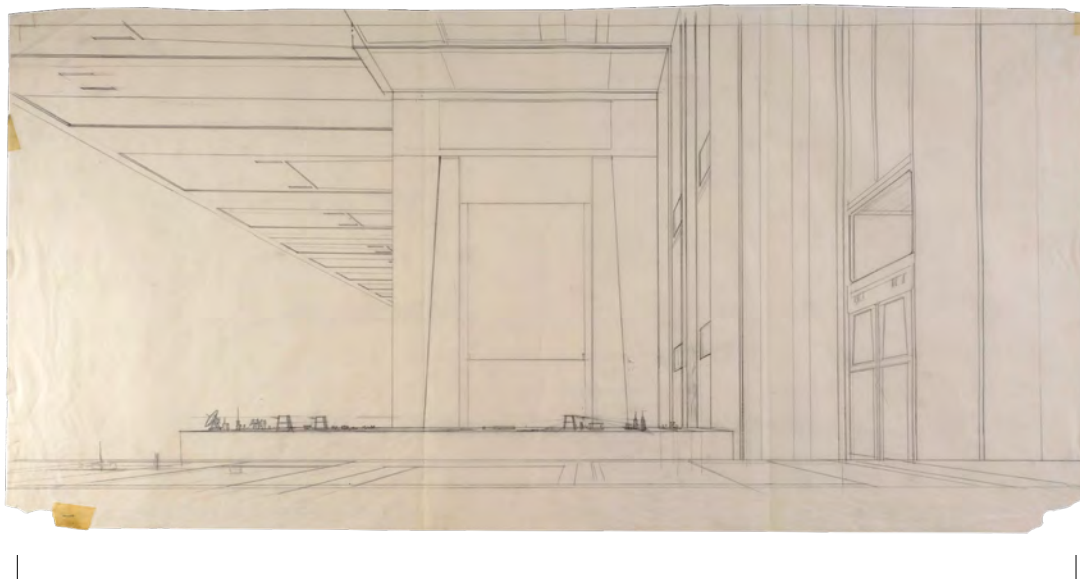

89 cm (35")

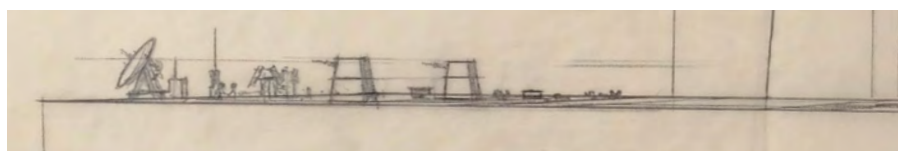

Sketch Detail

377
 Hand-drawn Ralph McQuarrie
 Death Star Docking Trench
 Illustration for Matte Painting
Star Wars: A New Hope (1977)

A Death Star docking trench illustration hand-drawn by Ralph McQuarrie for the production of George Lucas' Star Wars: A New Hope. McQuarrie worked on the film in multiple capacities, including the creation of several matte paintings seen in the final cut of the film.

This line art sketch was the start of a matte painting used for the scene in which the Death Star pulled the Millennium Falcon into its docking trench with its tractor beam.

McQuarrie frequently used a drawing on vellum as the first step in his painting process, and as such, this piece is rendered in graphite on vellum mounted to artboard. It was also featured in the Abrams publication Star Wars Art: Ralph McQuarrie by Abrams. The vellum exhibits small tears throughout. Dimensions: 89 cm x 43.75 cm (35" x 17.25")

Sold without copyright; see notice in Buyer's Guide.

Estimate. £7,000 - 10,000

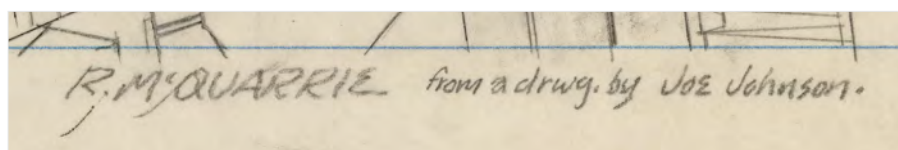
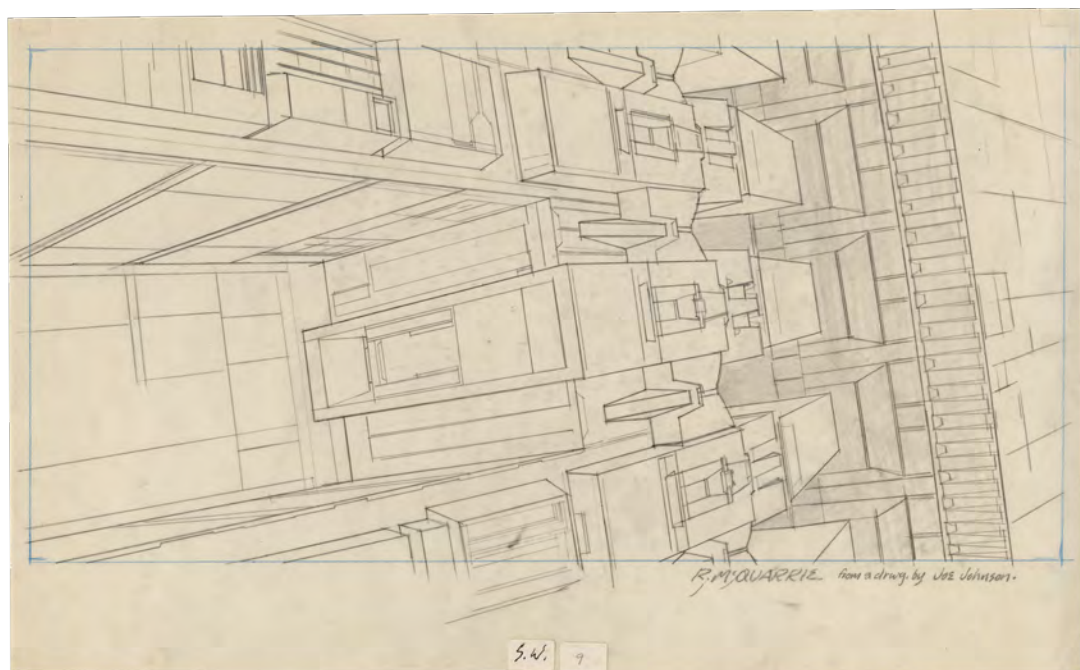

Signature Detail

378
 Hand-drawn Ralph McQuarrie
 "Fighters Low Over Death Star"
 Preliminary Drawing for
 Production Illustration
Star Wars: A New Hope (1977)

A preliminary drawing hand-drawn by Ralph McQuarrie for his "Fighters low over Death Star" production illustration for George Lucas' Star Wars: A New Hope. Production illustrator McQuarrie completed the final illustration depicting the Rebels' bombardment of the Death Star's surface on November 11, 1975.

This drawing is rendered in graphite across two sheets of bordered vellum taped together. The top sheet is labelled "S.W." and "9," and signed "from a drwg. by Joe Johnston" by McQuarrie.

This drawing is also featured on page 120 of the Abrams publication Star Wars Art: Ralph McQuarrie. The vellum exhibits mild discolouration and creasing. Dimensions: 47 cm x 26.75 cm (18.5" x 10.5")

Sold without copyright; see notice in the Buyer's Guide.

Estimate. £6,000 - 8,000



123 cm (48.5")

379
 Hildebrandt Quad Framed
Star Wars: A New Hope (1977)

A framed rare quad poster created by the Hildebrandt Brothers (Greg & Tim) for the promotion of George Lucas' Star Wars: A New Hope. Originally produced in 1977, this poster was a highly sought-after design. It had a limited release of one to two weeks before it was replaced by the Style C design featuring artwork by Tom Chantrell. Printed in England by W.E.Berry Ltd. Bradford, this version was rated 5.0/6.0 by starwarsmovieposter.com for rarity, making it the second rarest Star Wars poster ever. It was also given a 10/10 rarity rating by Stephen Sansweet's Star Wars Poster Book, which many consider the industry bible for Star Wars posters. Presented conservation linen-backed, the poster was previously folded but now appears rolled with minimal restoration undertaken before it was applied to the linen. The fold lines have been touched in and are now only evident upon close inspection. The lot has retained its deep unfaded dark colour tones and comes presented within a black wooden frame, which exhibits some minor scuffs. Dimensions (framed): 98 cm x 123 cm x 3 cm (38 1/2" x 48 1/2" x 1 1/4")

Estimate. £5,000 - 7,000



380
 Fourth Draft Script
Star Wars: A New Hope (1977)

A fourth draft script from the production of George Lucas' Star Wars: A New Hope. Dated January 1, 1976, this 145-page script bears the original title "The Adventures of Luke Starkiller", as taken from the "Journal of the Whills". Bound with a yellow card front and back cover, the script offers detailed insight into the creation of the first Star Wars film, and includes early character names and locations, many of which were omitted or changed by the time of filming. "421" is written in black ink on the first title page, and rust marks are present on the metal clip binding. Dimensions: 28 cm x 22 cm x 2 cm (11" x 8 1/2" x 3/4")

Estimate. £3,000 - 5,000

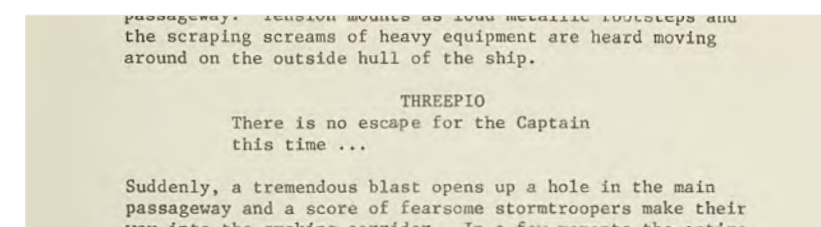



381
 Replica TIE Pilot Helmet Created from Original Moulds m
Star Wars: A New Hope (1977)

A replica TIE pilot helmet created from original moulds from the production of George Lucas' Star Wars: A New Hope. Pilots flying the various TIE starfighters in the Imperial Navy wore bulky, vacuum-sealed helmets when in combat. This helmet is a replica produced in the early 1980s and made of vacuum-formed plastic from the original production moulds. It was subsequently used in theatre productions.

The helmet consists of two parts – the shell and the face mask – which are screwed together. Hand-painted golden detailing is applied around the mouth-and-nose area and the front and centre of the shell. There is an adjustable plastic headband on the interior, and the helmet sits on a custom-made display stand. Some of the gold paint has worn away, there are some small cracks, and there are signs of repair on the interior. Dimensions: 37 cm x 32 cm x 30 cm (14 1/2" x 12 1/2" x 11 3/4")

Estimate. £3,000 - 5,000

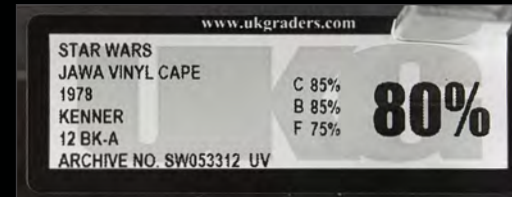

Grade Detail

382
 Jawa Vinyl Cape Action Figure UKG 80 m
Star Wars: A New Hope (1977)

A Jawa Vinyl Cape action figure, graded by the UK Graders (UKG), from the promotion of George Lucas' Star Wars: A New Hope. Released in 1978 as one of the original 12 Star Wars action figures, the coveted vinyl cape edition was the first Jawa design to be issued. However, after several complaints from customers, the cape material was changed to cloth to add perceived value to the toy. This makes the vinyl version incredibly rare, and one of the most sought after Star Wars figures.

The Kenner figure is housed in its original bubble on an unpunched SW12A card back. A UKG sticker with the toy's grading figure (80%) is adhered to the bottom of its plastic protective casing. There are signs of light edge wear, and the lot comes with a UKG certificate of authenticity. Dimensions: 25 cm x 19 cm x 4 cm (9 3/4" x 7 1/2" x 1 1/2")

Estimate. £10,000 - 15,000





383
Tauntaun Head m
Star Wars: The Empire Strikes Back (1980)

A hero Tauntaun creature head from Irvin Kershner's *Star Wars: The Empire Strikes Back*. Both Luke Skywalker (Mark Hamill) and Han Solo (Harrison Ford) rode Tauntauns on the ice planet Hoth.

Originally designed by Phil Tippett, who created and animated the stop-motion puppets used in wide shots, the full-size versions were built by legendary make-up effects artist Stuart Freeborn and his team. Different versions of the full-size creature were made for the production, and this particular head remains as one of only two surviving Tauntauns to this day, with the other in George Lucas' archives.

The Tauntaun features foam latex skin over a rigid polyurethane foam skull. It features plastic eyes with the remnants of the original mechanism which locked the eyeballs together and allowed them to move via cables; tubes which were used to pump smoke through the nostrils, imitating breath; springs used to open and close the jaw; resin teeth; faux fur on the chin and brows; and a nylon strap and aluminium bridle.

The skin had deteriorated over the years and has undergone sympathetic restoration, most notably around the nostrils, upper lip areas, and around the sides of the jaw, meaning it is now in a stable condition. The paint was blended with the rest of the head, leaving as much original paintwork as possible. The foam over the main part of the upper face remains intact.

It was restored by Tom Spina Designs and creatively mounted on the neck display cast from the original Tauntaun moulds, with the horns sculpted from references. It was previously displayed at a Planet Hollywood restaurant for 10 years. Dimensions (head on display): 167 cm x 61 cm x 57 cm (66" x 24" x 22 1/2")

Special shipping required: see special shipping notice in the Buyer's Guide.

Estimate. £60,000 - 100,000



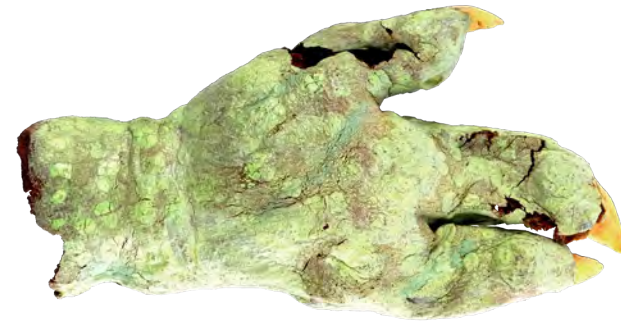

384
 Yoda's (Frank Oz) Hand Ω
Star Wars: The Empire Strikes Back (1980)

Yoda's (Frank Oz) hand from Irvin Kershner's *Star Wars: The Empire Strikes Back*. Luke Skywalker (Mark Hamill) sought out the self-exiled Jedi Master Yoda in the swamps of Dagobah. Yoda was brought to life on screen using a highly detailed puppet built by Stuart Freeborn and Industrial Light & Magic (ILM) with Oz operating and voicing the character.

This three-fingered foam latex hand with a white cloth interior is painted green with yellow resin fingernails and sculpted details, including wrinkles, knuckles, and veins. The latex exhibits stiffness from age, with cracking and chunks missing around the wrist, and the lot should be handled with caution. Dimensions: 18 cm x 12.75 cm x 5 cm (7" x 5" x 2")

Estimate. £10,000 - 15,000

385
 Hoth Rebel Technician Hat M
Star Wars: The Empire Strikes Back (1980)

A Hoth Rebel technician hat from Irvin Kershner's *Star Wars: The Empire Strikes Back*. Various Rebel technicians wore their hats as they worked within Echo Base on the ice planet Hoth. One unnamed technician is notably seen wearing this style of hat while loading R2-D2 into Luke Skywalker's (Mark Hamill) T-65 X-wing starfighter's droid socket.

The hat is made from beige cotton, with a soft peak at the front, ear-covering flaps and a pair of ties forming a chin strap. A diamond-shaped quilted style pattern is stitched all over the hat's bottom half, which covers the ears and back of the neck. The lot exhibits several stains, and the diamond-shaped stitching has some split seams.

Estimate. £6,000 - 8,000



386
 Bespin Guard Jacket \dagger
Star Wars: The Empire Strikes Back (1980)

A Bespin Guard jacket from Irvin Kershner's *Star Wars: The Empire Strikes Back*. The Bespin Guards were tasked with maintaining order on Cloud City, administered by Lando Calrissian (Billy Dee Williams). The Guards were under the control of Lando's cyborg aide Lobot (John Hollis). The collarless blue cotton jacket features decorative faux-gold braid detailing on the lower portion of the front and along the garment's edge. Its sleeve cuffs are burgundy with a black trim, and a strip of green-coloured Velcro® runs down the jacket's front. "Steven Collins Holland" is handwritten inside the right shoulder, with the middle name crossed out. The jacket displays some minor staining.

Estimate. £4,000 - 6,000



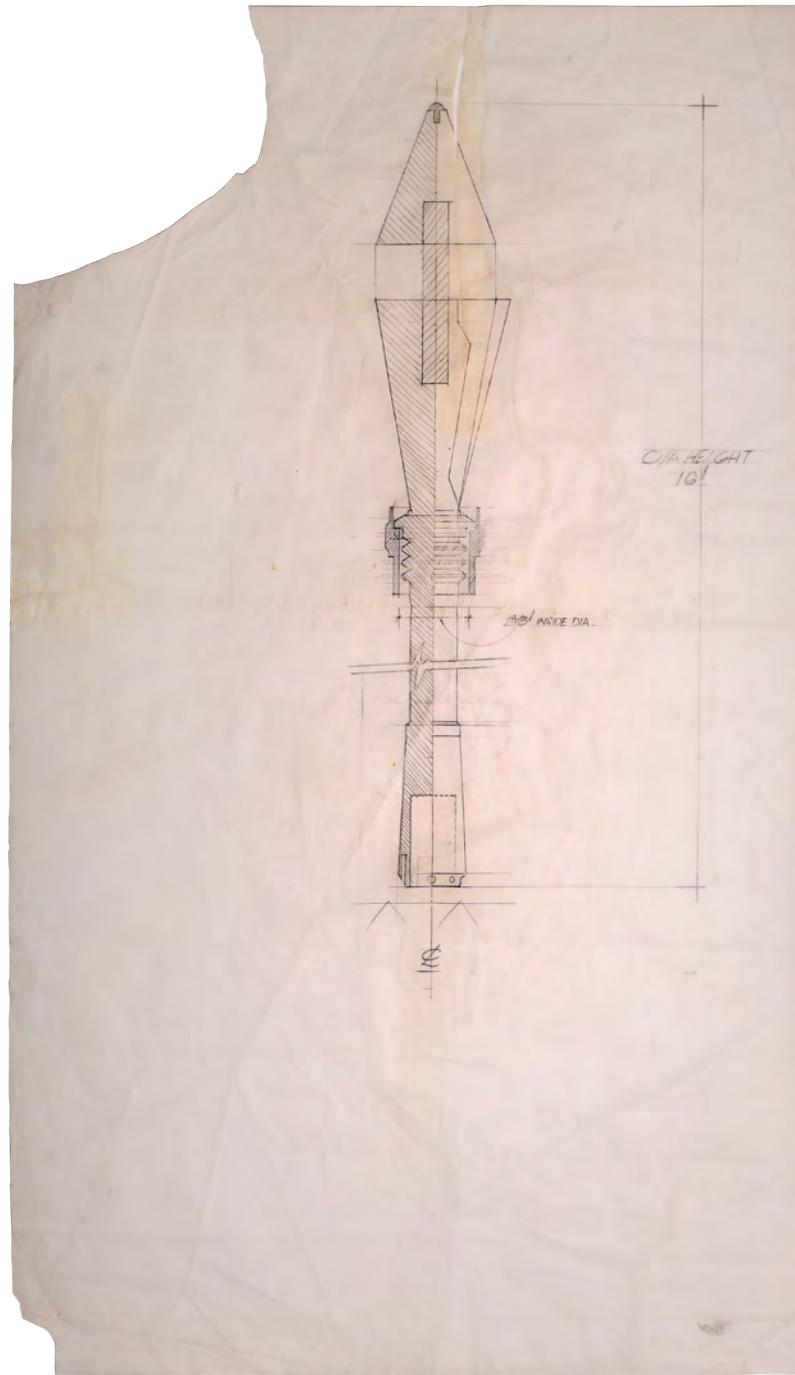

387
Norman Reynolds Hand-drawn Pencil Technical Illustration for Boba Fett's Jetpack Missile †
Star Wars: The Empire Strikes Back (1980)

A hand-drawn technical drawing of Boba Fett's jetpack missile from the production of Irvin Kershner's Star Wars: The Empire Strikes Back. Bounty hunter Boba Fett (Jeremy Bulloch) wore a modified version of the Z-6 jetpack with his armour while tracking down the Millennium Falcon.

Hand drawn by production designer Norman Reynolds, the detailed sketch shows the missile which fired from the jetpack, and includes measurements for its height and diameter. The sketch is rendered in pencil on tracing paper and comes presented in a black frame, with string on the reverse for wall mounting. The sketch exhibits signs of discolouration and tears, and the top left corner of the paper is missing. Dimensions (displayed): 78.5 cm x 53.5 cm x 1.5 cm (31" x 21" x 1/2")

Sold without copyright; see copyright notice in the Buyer's Guide.

Estimate. £4,000 - 6,000

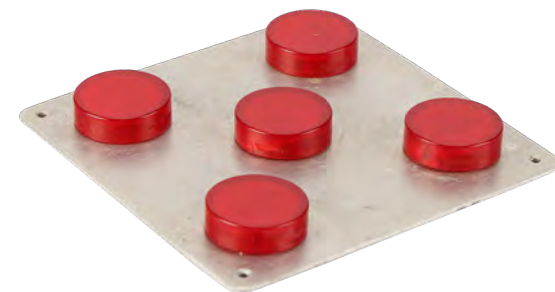
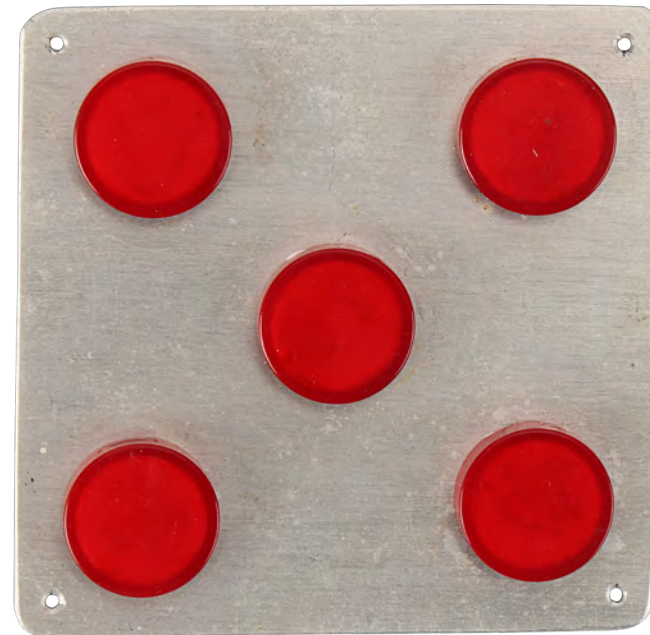

388
Rebel General Command Insignia †
Star Wars: The Empire Strikes Back (1980)

A Rebel general command insignia from Irvin Kershner's Star Wars: The Empire Strikes Back. Badges were worn by officers of the Rebellion to indicate the wearer's military rank.

The insignia comprises five red plastic circular rank tiles fastened to a square aluminium backing. This arrangement of five red dots denoted the rank of general and was notably worn by Carlist Rieekan (Bruce Boa). The badge exhibits scratches from production use. Dimensions: 6.5 cm x 6.5 cm x 0.5 cm (2 1/2" x 2 1/2" x 1/4")

Estimate. £3,000 - 5,000



389
Hoth Rebel Trooper Pistol Ω
Star Wars: The Empire Strikes Back (1980)

A Hoth Rebel trooper pistol from Irvin Kershner's Star Wars: The Empire Strikes Back. Soldiers fought for the Rebel Alliance and used their blaster pistols to defend themselves from the Empire's assault on the Rebel base on the planet Hoth.

The blaster pistol is made primarily of fibreglass, based on the combined body of an AR-7 with the grip of a Sterling L2A3, painted black, with a nonfunctional fibreglass scope attached to the top and a flared grey metal muzzle piece based on the finned rear of a mortar shell. The back of the scope shows evidence of a production repair, with a washer being installed to give it shape. The front of the scope features a small reflective lens. It exhibits scuffs in the black paint and a puncture through one side of the gun. Dimensions: 33.25 cm x 5.25 cm x 15.25 cm (13" x 2" x 6")

Ownership may be restricted in some countries; see replica firearm notice in Buyer's Guide.

Estimate. £15,000 - 25,000



390
 R2-D2's Foot us
Star Wars: The Empire Strikes Back (1980)
/Star Wars: Star Tours (1987 - 2020)

R2-D2's foot from George Lucas' Star Wars: The Empire Strikes Back and later, Disneyland's Star Wars: Star Tours. In the 1980s, Lucasfilm provided original props left over from the filming of the Star Wars trilogy to Star Tours, including one of R2's droid feet from The Empire Strikes Back, identified by its fibreglass construction, which replaced the aluminium used in the first film. This foot was specifically from a radio-controlled prop version of R2 as opposed to a costume prop version for actor Kenny Baker, prior to being repurposed as part of a conveyor belt of droid components which visitors passed while queuing for Star Tours.

Constructed from fibreglass and painted in R2's signature off-white and blue, this foot is currently affixed with a metal cable that was added when the piece was installed into Star Tours in order to suspend it from the attraction's ceiling, but the cable could be removed if desired. The foot features black slatted panelling on bottom, faux metal detailing on the sides, and two false wires on the back. The lower tread detail on the bottom of the foot was also added during its Star Tours installation. The metal plate on the inside of the foot can be opened and there is a welded metal bracket present where a wheel mechanism was once mounted during filming. The foot is covered in dust and grime from years of operation on Star Tours, and screws affixing the panels to one another exhibit rust from age. Dimensions: 35.75 cm x 23 cm x 25.5 cm (14" x 9" x 10")

Estimate. £25,000 - 35,000



25.5 cm (10")

Additional detailing was added to the bottom of the foot for Star Tours, where the underside was visible

Metal cables were added to the foot to install it in the Star Tours ride



391
 C-3PO's (Anthony Daniels) Hand M
Star Wars: The Empire Strikes Back (1980)
/ Star Wars: Return Of The Jedi (1983)

C-3PO's (Anthony Daniels) hand from George Lucas' Star Wars: The Empire Strikes Back and Star Wars: Return of the Jedi. Protocol droid C-3PO accompanied Luke Skywalker (Mark Hamill) on his journey to defeat the Empire.

This polyurethane right hand features a silver finish, and the palm is painted to look like wiring. There is a split along the wrist and into the palm, with several small pieces of string threaded through the polyurethane to secure it in place. The silver finish has worn away in several places across the hand and there are additional splits in the polyurethane. Dimensions: 23 cm x 14 cm x 7.5 cm (9" x 5 1/2" x 3")

Estimate. £10,000 - 15,000



392
 Ewok Head Created Using Stuart Freeborn's Production Components M
Star Wars: Return Of The Jedi (1983)

An Ewok head from the production of Richard Marquand's Star Wars: Return of the Jedi. Legendary make-up artist Stuart Freeborn oversaw the creation of the Ewoks on the film, as well as iconic characters Yoda, Chewbacca and Jabba the Hutt. This head was created by piecing together original production-made components from Freeborn's workshop.

The head is made from foam and rubber and is covered in faux fur. It has a foam nose, ears and lips, with acrylic eyes and resin teeth. "J.C." is handwritten in marker inside the top of the head and a sticker on its interior notes that it was assembled by sculptor and FX artist Tom Spina.

Estimate. £8,000 - 12,000



Right Bracelet Detail

393
Leia's (Carrie Fisher) Production-used Slave Costume 
Star Wars: Return Of The Jedi (1983)

Leia's (Carrie Fisher) production-used slave costume from Richard Marquand's *Star Wars: Return of the Jedi*. Princess Leia was forced to wear a dancing girl costume while enslaved by the vile gangster Jabba.

The famous bikini costume was sculpted by Richard Miller, the chief sculptor at Industrial Light & Magic, based on designs by co-costume designer Nilo Rodis-Jamero. Miller approached the costume with a jeweler's methodology and produced wax sculptures of the sculpted elements that could be shaped to fit Fisher exactly, from these wax masters he produced test castings in various resins and then cast final components in a red-colored urethane rubber. This costume is made up of production-used elements from the sculptor's collection including a test casting of the ornamental harness top piece made from white resin; a bottom piece made up of four sections (the front and side sections are cast in urethane, and the back plate is an original wax piece); a urethane bracelet; a spiral-snake upper armband that is an original wax element, and a pair of prototype beige leather lace-up boots. These prototype boots were worn by Fisher in costume fittings tests. The costume's textile elements - including the brown suede lining and cross cord lacing on the top, and the two burgundy silk skirt veils - are reproductions made to complete this production-used costume.

Accompanying the lot is a framed print of a behind-the-scenes photograph of Fisher in the costume and the prototype boots, and a signed letter of authenticity from Miller, in which he describes his creative process. The lot exhibits wear, including discoloration, paint-wear revealing the costume's white resin and red rubber structure, and splits in the rubber armband revealing the wire armature.

Estimate. £40,000 - 60,000



Maximum Film / Alamy Stock Photo

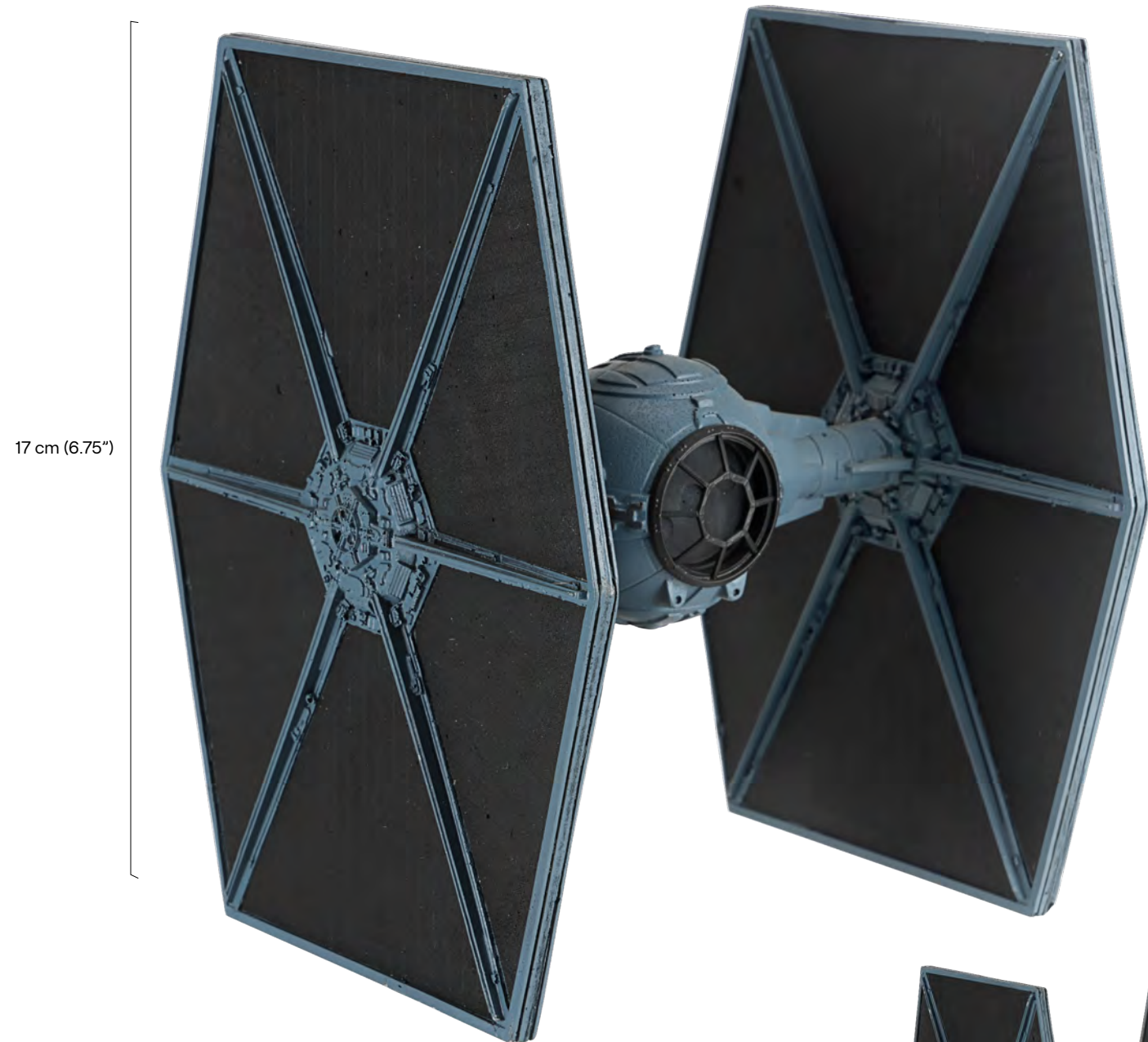

394
ILM TIE Fighter Model Crew Gift M
Star Wars: Return Of The Jedi (1983)

An ILM TIE fighter model crew gift from the production of Richard Marquand's Star Wars: Return of the Jedi. TIE fighters were the standard Imperial starfighter, and known for their iconic "H" shape and hexagonal wings. Industrial Light & Magic made a very limited number of additional models as gifts for executives and senior crew members. The models were made from original moulds during or just after production wrapped, and only a handful are known to exist.

The model is made of resin and is hand-painted black and grey by the highly regarded ILM team. It sits on a custom-made display stand and presents in excellent condition. Dimensions: 14 cm x 14 cm x 17 cm (5 1/2" x 5 1/2" x 6 3/4")

Estimate. £8,000 - 12,000



395
Death Star Gun Tower
Miniature Model M
Star Wars:
Return Of The Jedi (1983)

A Death Star gun tower miniature model from Richard Marquand's Star Wars: Return of the Jedi. Gun towers covered the Death Star's surface and constantly fired at the attacking Rebel pilots during the film's climax.

Constructed by Industrial Light and Magic from biscuit foam and resin, the grey-painted gun tower features a futuristic industrial design, with grid lines carved into its sides to simulate a panelled construction. The body of the gun tower slopes to a wider base for stability. While static, the tower's top portion resembles a rotating gun turret. Two laser cannons are missing at the top, and one of the tower's top corners displays a small chip. Dimensions: 3.5 cm x 3.5 cm x 12 cm (1 1/4" x 1 1/4" x 4 3/4")

Estimate. £5,000 - 7,000

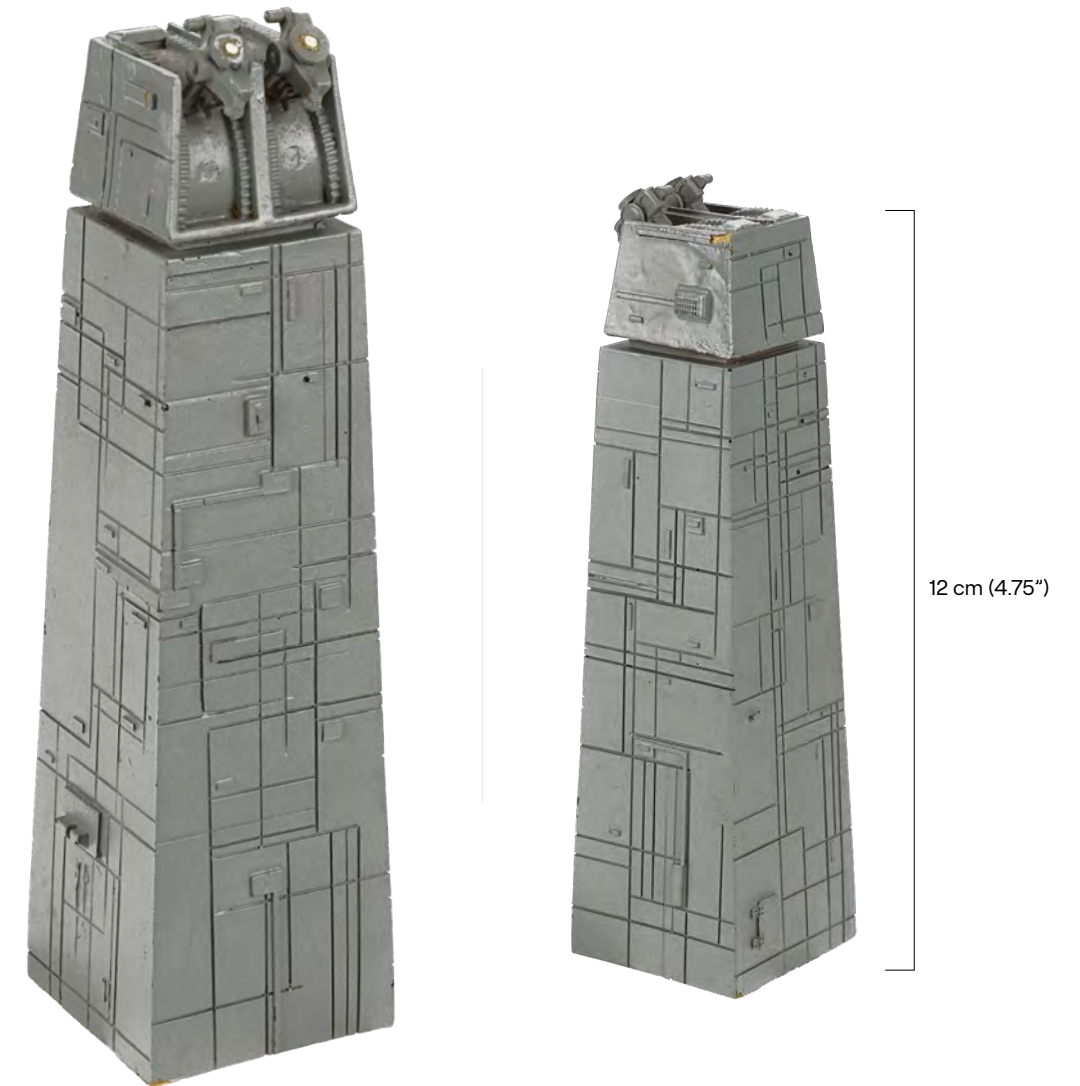

396
Hand-Painted Frank Ordaz
Millennium Falcon
Matte Test Artwork Ω
Star Wars:
Return Of The Jedi (1983)

A hand-painted Frank Ordaz Millennium Falcon matte test artwork from Richard Marquand's Star Wars: Return of the Jedi. After meeting back up with the Rebel Alliance, Han Solo (Harrison Ford) gave Lando Calrissian (Billy Dee Williams) permission to use the Millennium Falcon.

This lot consists of a mixed media matte painting on poster board. Achieved by painting acrylic directly onto a glossy photograph of the Millennium Falcon, this piece of art depicts the freighter on the MC80 Command Cruiser Home One, with its ramp extended. Black painter's tape borders the top and bottom of this painting and wraps around to the other side. This lot exhibits frayed edges, lifting tape, and notable glue marks on the back. Dimensions: 34.5 cm x 29.25 cm (13.5" x 11.5")

Sold without copyright. See notice in the Buyer's Guide.

Estimate. £4,000 - 6,000

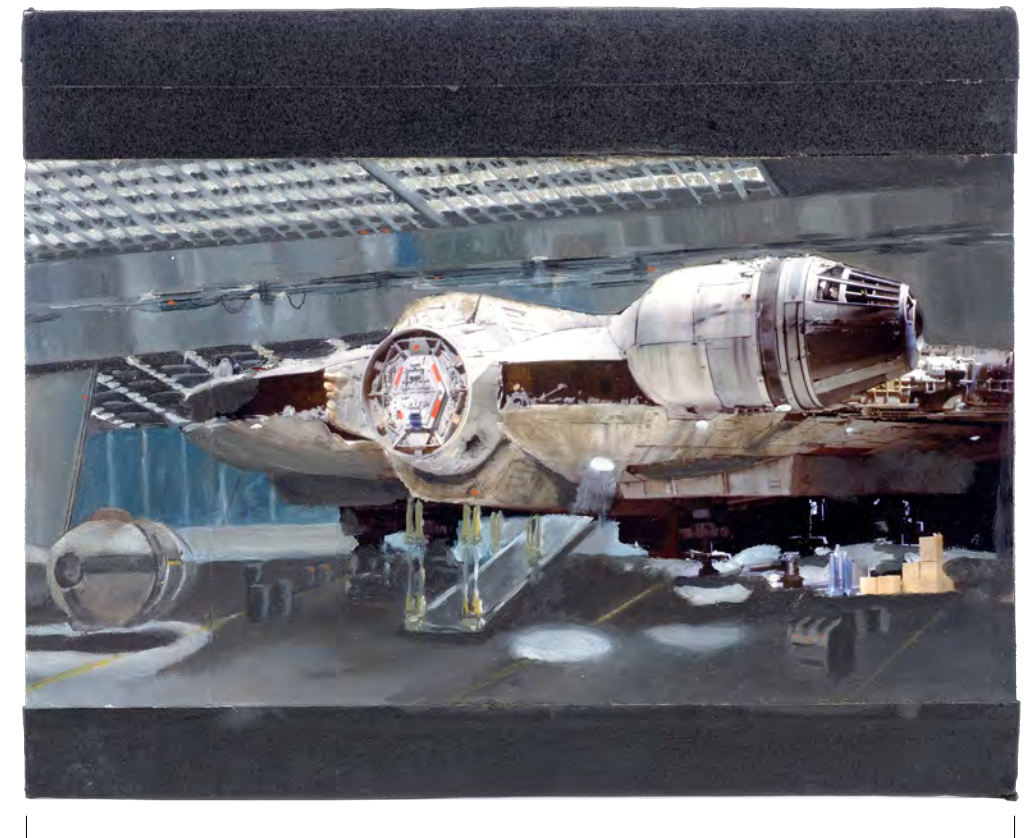

34.5 cm (13.5")

397

**Promotional Chirrut Imwe (Donnie Yen)
Replica Costume Display us
Rogue One: A Star Wars Story (2016)**

A Chirrut Imwe (Donnie Yen) replica costume display from the promotion of Gareth Edwards' Rogue One: A Star Wars Story. In late 2016, World Duty Free and Disney collaborated on a seven-week promotional exhibition featuring replicas of lead character costumes.

This replica of Chirrut's signature costume as seen on Jedha and during the Battle of Scarif was created by the film's production team for the campaign. It consists of a padded grey-blue suede wrap-around top with yellow stitching ; a matching mixed fabric shoulder cape; a white leather ammunitions harness; a matching bracer with resin armour; grey mixed fabric trousers; a red cotton skirt; a black woven asymmetric skirt with a decorative red stripe; and a pair of brown Chelsea boots. Also included is a fibreglass staff designed to resemble carved wood with silver-colour resin components.

This costume comes dressed on a custom mannequin affixed with a plaque featuring the Rogue One title artwork and a description of the character's history. It is intentionally distressed by production to appear well-worn with scuffs on the leather, frayed fabric, and staining throughout. Dimensions (displayed): 50 cm x 100 cm x 159 cm (19.75" x 39.5" x 62.75")

Special shipping required; see notice in the Buyer's Guide.

Estimate. £20,000 - 30,000



398

**Promotional Jyn Erso (Felicity Jones)
Replica Costume Display us
Rogue One: A Star Wars Story (2016)**

A Jyn Erso (Felicity Jones) replica costume display from the promotion of Gareth Edwards' Rogue One: A Star Wars Story. In late 2016, World Duty Free and Disney collaborated on a seven-week promotional exhibition featuring replicas of lead character costumes.

This replica of Jyn's signature costume, including the scarf she added when she visited the planet Jedha, was created by the film's production team for the campaign. It consists of a grey fabric scarf; a brown suede utility vest with a decorative faux silver Rebel Alliance badge; a grey cotton bomber-style zip-up jacket with yellow strips on the sleeves and decorative stitching throughout; a matching grey shirt with an overlapping collar; a pair of brown leather fingerless gloves; tapered black fabric blend trousers; a brown leather belt and thigh holster; and a pair of elevated brown leather boots.

The holster houses a plastic Rebel Alliance A180 pistol finished in black and silver-colour plastic and a dark grey resin tonfa baton . This costume comes dressed on a custom mannequin affixed with an informational plaque featuring the Rogue One title artwork and a description of the character's history. It is intentionally distressed by production to appear well-worn with scuffs on the leather, frayed fabric, and staining throughout. Dimensions (displayed): 50 cm x 100 cm x 156 cm (19.75" x 39.5" x 61.5")

Special shipping required; see notice in the Buyer's Guide.

Estimate. £30,000 - 50,000





399
Light-up Remote-control
R5-PHT Droid M
Solo: A Star Wars Story (2018)

A light-up remote-control R5-PHT droid from Ron Howard's Solo: A Star Wars Story. The Imperial astromech droid R5-PHT was seen at the Coronet Spaceport on Corellia, just after Han (Alden Ehrenreich) was separated from Qi'ra (Emilia Clarke). The droid was later recreated as an action figure as part of the Star Wars: Droid Factory toy set.

Constructed by Glynn Turner, the droid was originally going to feature an R2-style dome, but an existing R5 dome was used instead, spray-painted to match the body. During the time that directors Phil Lord and Chris Miller were on the project, the scene involved Han running into the droid, causing it to project an Imperial Army recruitment hologram (boot scuff marks remain on the droid's middle foot). It then moved to the left of the recruitment area as Han talked with the recruitment officer. This scene appeared in the film's Super Bowl trailer in February 2018, but was cut when Ron Howard took over directing duties after Lord and Miller quit. In the final film, the recruitment hologram is not projected by the droid, and Ron Howard's wife Cheryl makes a cameo standing in front of the droid while Han watches the hologram. The R5-PHT droid also features on page 37 of "Solo A Star Wars Story The Official Guide".

The droid comprises a plywood frame and legs with aluminium skins and feet. The dome is made of styrene with resin details; it is a replica of the one used in the film, built to the same specifications and with the same paint. Because of its original role in the film, the droid features a holoprojector on its dome, and was the first R5 unit to use one.

The droid is accompanied by two remote controls, one for the droid's movement, and one for the holoprojector. The lot also includes two mains charging cables; a sheet from the day of filming; a Star Wars: Droid Factory toy set which features R5-PHT; and two collectable cards, both of which feature the droid (one also includes a Stormtrooper patch). Dimensions: 72 cm x 72 cm x 135 cm (28 1/4" x 28 1/4" x 53 1/4")

Contains electronics; see electronics notice in the Buyer's Guide.

Special shipping required; see special shipping notice in the Buyer's Guide.

Estimate. £50,000 - 80,000

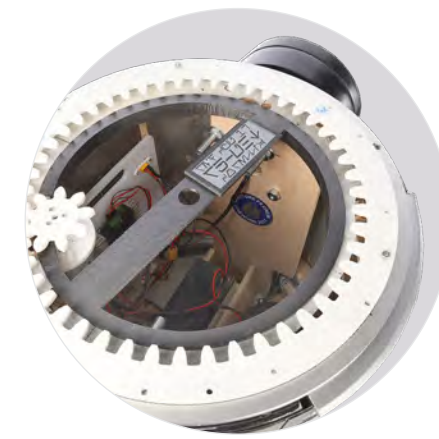

Body Interior



400
Stormtrooper Costume Ω
Mandalorian, The (T.V. Series, 2019 - 2022)

A stormtrooper costume from Jon Favreau's Star Wars television series The Mandalorian. Stormtroopers appeared throughout the series in costumes created by the 501st Legion, a fan group dedicated to creating screen-accurate Stormtrooper suits. This particular suit was worn in the Season 1 episodes "The Reckoning" and "Redemption."

Consisting of white, vacuum-formed plastic components, this costume includes a hand-painted helmet with a green-tinted visor; a chest and abdominal plate featuring decorative grey and blue buttons; three segmented back plates connected by black straps; a pair of plated pauldrons with connected elastic straps labelled for "R" and "L"; forearm, leg, hand, and thigh armour; leg armour plates; a belt with dropboxes and a black holster; a removable thermal detonator; and a pair of white leather Chelsea boots.

The underlayer of the costume consists of a black ribbed neck polyester dickey; black long-sleeved polyester Under Armour shirt; black polyester/nylon belt with a plastic buckle; black polyester trousers; and black polyester gloves with silicone grip texture. This costume exhibits scuffing, minor marks on several armour components, and discolouration on the boots.

Estimate. £10,000 - 15,000



401
Light-Up Stormtrooper
E-11 Blaster Rifle Ω
Mandalorian, The
(T.V. Series, 2019 - 2022)

A light-up Stormtrooper E-11 blaster rifle from Jon Favreau's Star Wars television series The Mandalorian. Stormtroopers appeared throughout the series carrying blaster rifles that were created by the 501st Legion, a fan group dedicated to creating screen-accurate Stormtrooper suits and blasters. This particular blaster rifle was carried in the final episodes of Season 1, "The Reckoning" and "Redemption."

This blaster is made of plastic painted black and silver-colour. Pressing the trigger both illuminates the red light at the end of the barrel and produces a blaster-like sound. This blaster rifle exhibits chipped paint and frayed wire laces. Dimensions: 47 cm x 21 cm x 14 cm (18.5" x 8.25" x 5.5")

Contains electronics; see electronics notice in the Buyer's Guide.

Estimate. £4,000 - 6,000



402
Darth Vader's (Richard Cetrone)
Light-Up Costume Ω
Star Wars: Sc 38
- Reimagined (2019)

Darth Vader's (Richard Cetrone) light-up costume from Philip Silvera's fan-remake Star Wars SC 38 Reimagined. A reimagining of Scene 38 from George Lucas' Star Wars, the fan project shot new footage to create a more elaborate final duel between Darth Vader and Obi-Wan Kenobi (Dan Brown).

This costume consists of a two-piece fibreglass helmet; a black synthetic-blend cowl; a fibreglass mantel and pauldrons, a polyester-satin cape with matching tunic, a quilted leatherette jumpsuit, a light-up chest control box with nylon straps; a pair of leather gloves; a leather codpiece with an attached belt featuring two light-up control boxes; a pair of plastic greaves with fastening-strip straps; and a pair of tall leather boots. The costume features Anovos and Rubies components with customizations for stunt work. The plastic and fibreglass materials exhibit scuffing and the leatherette jumpsuit exhibits extensive flaking.

Contains electronics; see electronics notice in the Buyer's Guide.

Estimate. £8,000 - 12,000



403
Horus Guard Costume and Continuity Polaroid m
Stargate (1994)

A Horus guard costume and a continuity Polaroid from the production of Roland Emmerich's sci-fi adventure film Stargate. Horus guards protected Ra (Jaye Davidson) on Abydos.

The costume comprises a fibreglass belt with a partial skirt (labelled "Chuck"); a pair of metal bracers; a pair of foam-rubber armbands; a metal shell-like accessory; and additional fabric (labelled "Chuck as Djimon"). Each piece has been painted and distressed to look tarnished and well-worn. The costume is accompanied by a continuity Polaroid labelled "Horus #5" and "Charges Toward Kwalasky [sic]", and a wardrobe department sheet with handwritten notes detailing a Horus costume. Some of the costume pieces feature paint wear.

Estimate. £4,000 - 6,000



404
Chris Achilleos Hand-painted Poster Art Concept m
Supergirl (1984)

A hand-painted poster concept artwork for the promotion of Jeannot Szwarc's superhero film Supergirl. This impressive image was created by artist Chris Achilleos, who was commissioned by Warner Bros' European headquarters. However, it was ultimately unused due to a change of distribution rights.

The design features Supergirl (Helen Slater) standing atop planet Earth, with clouds and a star field in the background, and the film's title at the bottom. It is rendered in airbrushed waterproof inks on illustration board, and signed and dated 1984. Displaying minor wear around the bottom edge, the artwork remains in very good condition. Dimensions: 108 cm x 78 cm (42 1/2" x 30 3/4")

Sold without copyright; see notice in the Buyer's Guide.

Estimate. £3,000 - 5,000

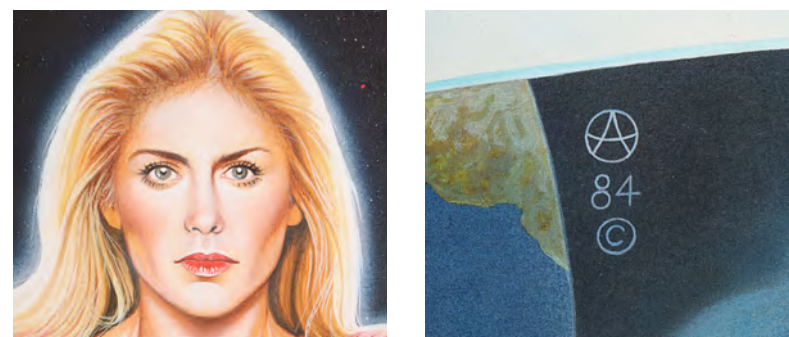

405
Supergirl's (Helen Slater) Flying Costume with m
Cut-down Superman (Christopher Reeve) Cape m
Supergirl (1984)

Supergirl's (Helen Slater) flying costume with a cut-down Superman (Christopher Reeve) cape from Jeannot Szwarc's superhero film Supergirl. Supergirl wore her iconic red, blue and yellow costume throughout the film, and this particular one was created for flying scenes.

The costume's blue leotard has holes in each side through which a harness could be attached to Slater. The rest of the costume comprises a red skirt with a sewn-in yellow belt; a pair of red knee-high boots; and a red cape with the iconic yellow "S" symbol. The cape was originally created for Christopher Reeve as Superman, and has since been cut down to the correct length to be used by Slater as Supergirl.

The costume is presented on a custom-built display with an "S" symbol-shaped base, which illuminates when powered. The costume has some wear from use and age. It is discoloured and stretched in several places, and the cape has many small holes across it. The zip at the back of the leotard is locked in one position. Dimensions (display): 41 cm x 80 cm x 167 cm (16 1/4" x 31 1/2" x 65 3/4")

Special shipping required; see special shipping notice in the Buyer's Guide.

Estimate. £20,000 - 30,000

406

Superman's (Christopher Reeve) Complete Costume m
Superman Franchise (1978-1987)

Superman's (Christopher Reeve) complete costume from Richard Donner's superhero film Superman and its sequels Superman II and Superman III, both directed by Richard Lester. A groundbreaking film, the original Superman brought a sense of legitimacy to the superhero genre and earned numerous accolades for its storytelling and visual effects. The first two films were shot back-to-back and, where possible, the costumes were also reused in the third film. This costume comprises a tunic, a cape, a pair of trunks, a belt, a pair of leggings and a pair of boots.

Superman's instantly recognisable long-sleeved tunic is made of a custom-woven, stretchy blue nylon material manufactured during production, and displays Superman's classic "S" logo in red and gold on the chest. The tunic has a hidden zipper at the back, and features a Bermans & Nathans wardrobe label stitched near the neck that reads "CHRISTOPHER REEVE NORMAL 18628 SUPERMAN 3", to differentiate it from the costume worn by the evil Superman in Superman III, which was a darker blue.

The leggings are made of the same material, and include a handwritten label that reads "S/7 NEW 22/5/78". The red trunks feature an elastic waistband and include a yellow-painted leather belt labelled "CHRISTOPHER REEVE Harness 15129 SUPERMAN II" which fastens at the back with hook-and-bar closures.

The knee-length cape is made of red wool and attaches to the tunic via snap-buttons on the shoulders. The back of the cape features a yellow-stitched "S" logo with black threading. Two labels are stitched inside, one reading "REMADE JULY/82 HB 24", and the other reading "CHRIS REEVE FLYING CAPE 14-9-79". This indicates that the cape was made for the original film, and then remade for the third. It was created for the flying sequences and features tabs at the bottom, where rods were inserted and moved to give the illusion of flight. There were previously two holes in the cape to attach a harness, but these were subsequently stitched up.

Superman's knee-high boots are made of red leather and close at the back with a zipper hidden behind a leather flap. They were intended for the flying scenes and feature red tape on the soles to make them look perfectly smooth.

This classic, iconic costume is mounted on a bespoke mannequin with a painted lifecast of Christopher Reeve to complete the display. The statue is mounted to a metal base in the shape of Superman's emblem, with a rod entering the left boot through its zipper, which is stitched shut. The complete costume shows minor wear due to production use and age. Dimensions (on display): 91.5 cm x 51 cm x 198 cm (36" x 20" x 78")

Special shipping required; see special shipping notice in the Buyer's Guide.

Estimate. £250,000 - 500,000



Motionline / Shutterstock



Warner Bros / DC Comics / Kobal / Shutterstock

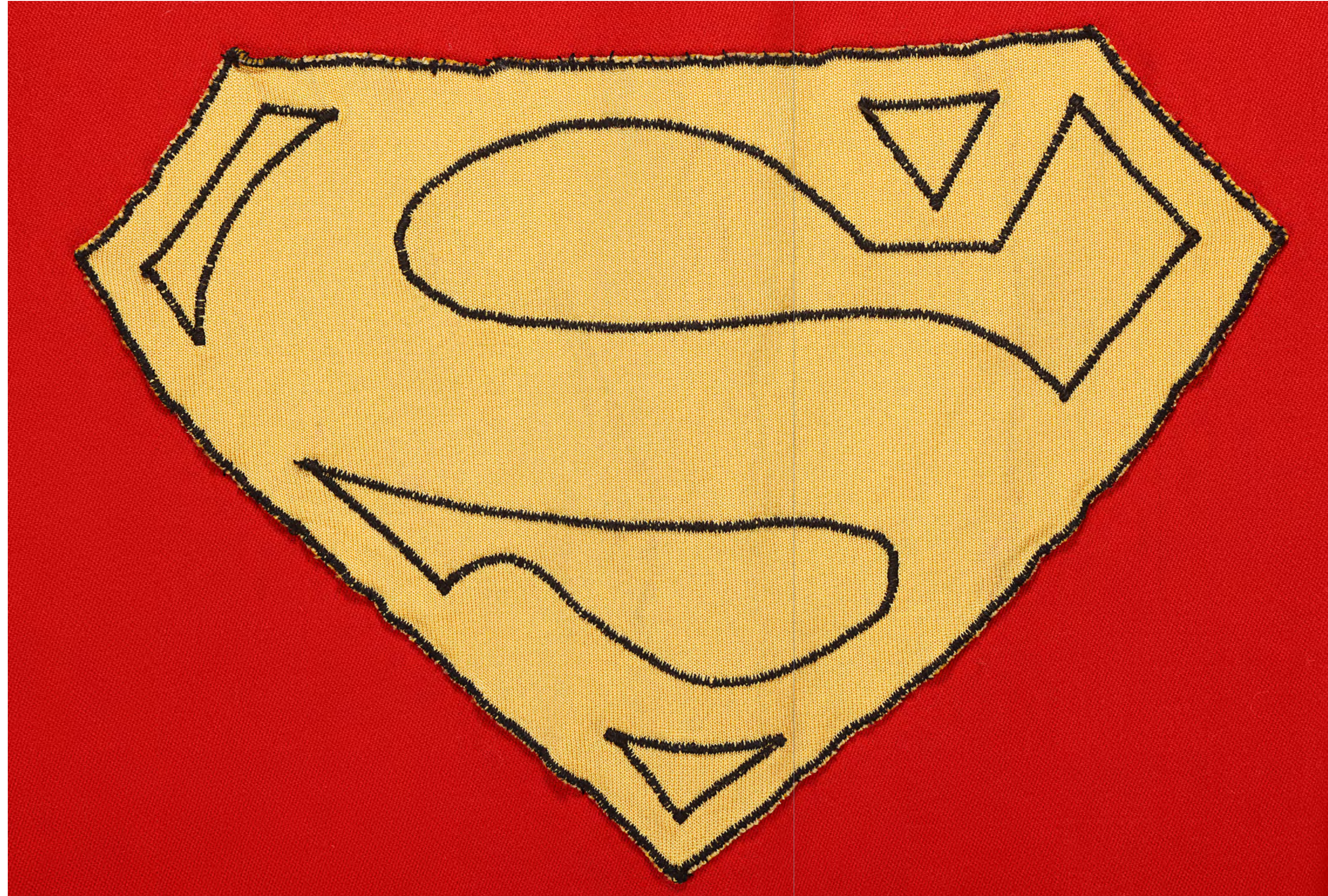

Warner Bros / DC Comics / Kobal / Shutterstock



Shutterstock





407
Model Unit Clapperboard M
Superman (1978)

A model unit clapperboard from the production of Richard Donner's superhero film Superman. This wooden clapperboard features the film's title at the top, and "2A Model Unit" handwritten on tape next to it. The director is listed as Brian Smithies and the cameraman is Les Dear. Smithies later worked on David Lynch's Dune and James Cameron's Aliens, and was the modeller head of department on Bond movie GoldenEye.

The clapperboard is dated "25-8-78" and some numbers are written in chalk on the front, although they are partially rubbed out. The back has "Test with Anamorphic" written clearly in chalk and what appears to be the word "Magnifier" below, although this is faded. The board has some chips to the wood and the metal hinge is rusted. Dimensions: 36 cm x 38 cm x 1.5 cm (14 1/4" x 15" x 1/2")

Estimate. £4,000 - 6,000

408
Christopher Reeves' Autographed Release Scripts and Crew Jersey \dagger
Superman (1978)

Christopher Reeve's autographed release scripts and a crew jersey from the production of Richard Donner's superhero film Superman. These items were personally gifted by Reeve in a competition on the BBC TV show Multi-Coloured Swap Shop in 1980, and later auctioned on BBC's Flog It! in 2018.

This lot consists of Reeve's personal Superman release script, split into two black leather-bound books, and a navy front-zip hooded jersey (size S) featuring a metallic "S" insignia on the back. The first half of the script is dated "1978" and comprises 171 pages, while the second half contains 180 pages, all printed on single-sided white paper. The title page found in the first script features Reeve's autograph, signed in blue pen, alongside a handwritten dedication to the winner of the TV show competition, which he's dated "8 February 1980". Accompanying this lot is an official BBC letter addressed to the competition winner congratulating them on winning their prize. Dimensions (each script): 32 cm x 23 cm x 2.5 cm (12 1/2" x 9" x 1")

Estimate. £5,000 - 7,000

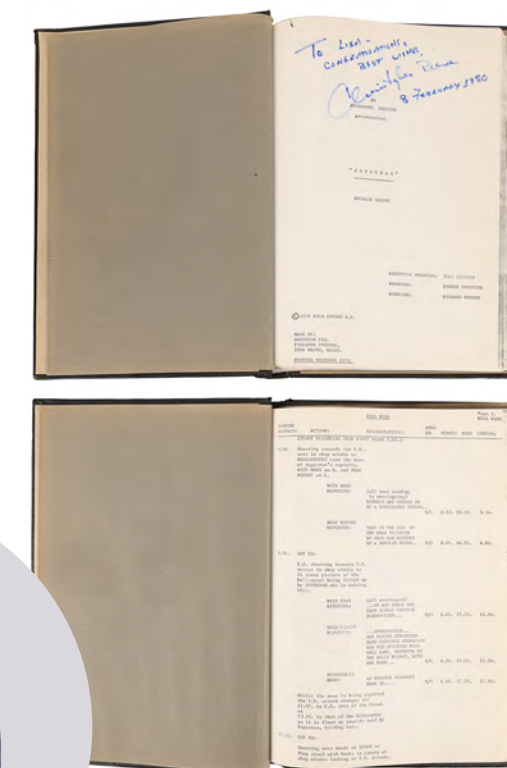
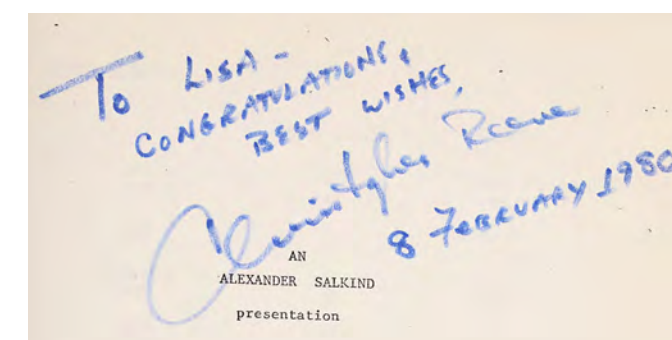

409
Model Unit Clapperboard $\dagger\Delta$
Superman (1978)

A model unit clapperboard from the production of Richard Donner's superhero movie Superman.

The clapperboard is made of black-painted wood. It features the film's title and unit title painted in white, with several pieces of tape applied bearing handwritten notes such as "Dir. Brian Smithies", "Cam. Paul Wilson" and "23 June '78". On the back are several numbered pieces of tape, likely used to denote the scene and take numbers. The paint had worn away in certain places exposing the wood. Dimensions: 46 cm x 23 cm x 1 cm (18" x 9" x 1/4")

Estimate. £3,000 - 5,000

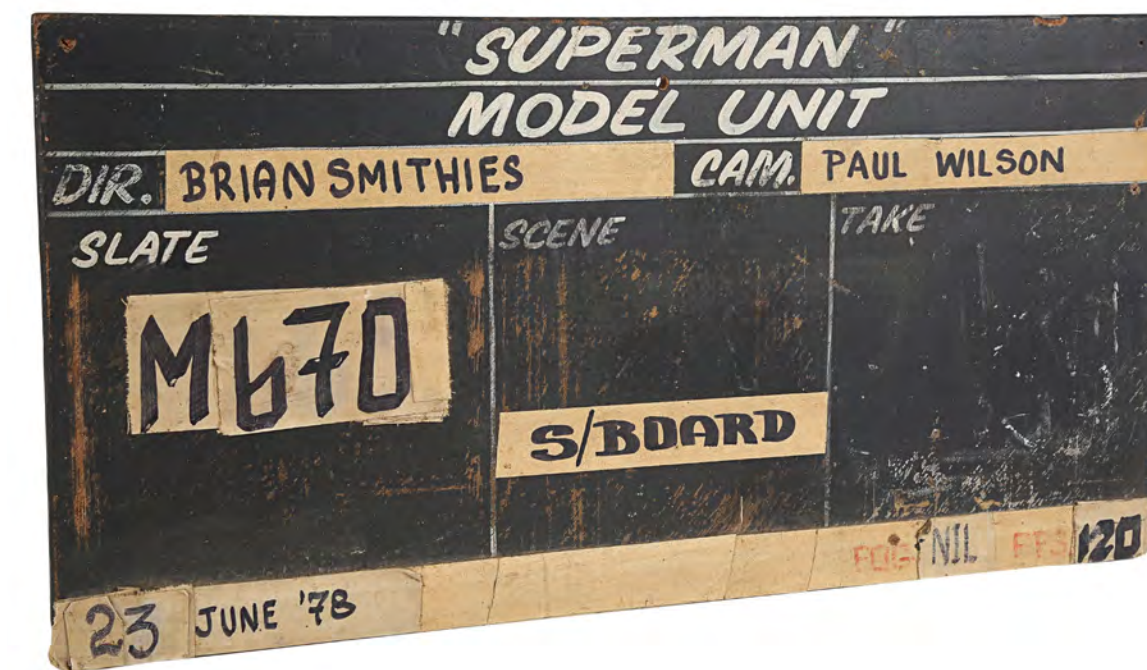



410
 Ursa's (Sarah Douglas) Complete Costume M
Superman II (1980)

Ursa's (Sarah Douglas) complete costume from Richard Lester's superhero sequel Superman II. One of the Kryptonian criminals led by General Zod (Terence Stamp), Ursa wore her costume throughout the film as she descended upon Earth after being freed from the Phantom Zone, in which they were imprisoned.

This costume consists of a sheer black voile jumpsuit, a matching belt, and a pair of thigh-high shiny black leather boots. The jumpsuit features a matt black nylon trim, with black faux-leather piping that runs around the neckline, down the crotch, and down the wrists. Each leg and sleeve has a side split opening, and a printed costumer's label is sewn into the back of the jumpsuit; this reads "Sarah Douglas, 15153 Harness, Superman II". The right boot features a zip closure down the inside seam, while the left boot's zip closure is located along the back seam.

Also included are three promotional stills of Douglas in her costume, and a group on-set photograph depicting Ursa, General Zod and Non (Jack O'Halloran), which has been autographed by each performer in silver pen.

The costume comes presented on a custom headless mannequin mounted on a black display stand. This lot exhibits wear from production use and age, including a strip of tape replacing the hook-and-eye fasteners on the belt; patches of black tape applied to the boots to fix imperfections; and a broken zip closure on the left boot, which has been sewn up loosely to secure it in place. Dimensions: 175 cm x 83 cm x 50 cm (69" x 32 3/4" x 19 3/4")

Special shipping required; see special shipping notice in the Buyer's Guide.

Estimate. £30,000 - 50,000

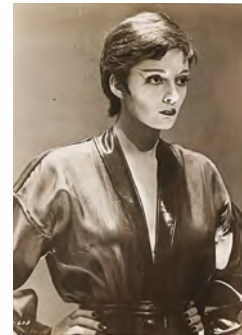

Photo 12 / Alamy Stock Photo



411
General Zod's (Terence Stamp) Thigh Boots M
Superman II (1980)

General Zod's (Terence Stamp) thigh boots from Richard Lester's superhero sequel Superman II. Kryptonian villain Zod wore his boots throughout the film, including during his expulsion from Krypton and his confrontations with Superman in Metropolis and the Fortress of Solitude. Zod also wore his boots during his brief appearance in the first film of the franchise, Superman, with which this sequel was filmed back-to-back.

The dark brown laceless boots have a protruding pointed front collar, a tan leather interior and a vinyl outer layer. Each boot has a vertical 25 cm zipper that runs from the arch to mid-calf. The vamp and shaft of the boots display vertical and diagonal linear seams, while their outsoles are flat, with welted outer stitching. A stitched label inside each boot features the handwritten word "WATER", suggesting the boots were worn when Zod walked on water after landing on Earth. Handwritten beneath the inner collar of each boot is "MR WESTON". This may refer to Paul Weston, a stunt coordinator on the film, who possibly performed the water-walking stunt.

The pull tab on the zipper of both boots is jammed and there is a 12 cm tear on the vinyl of the left boot, parallel to the zip. The boots show further signs of production wear but they are otherwise in good condition. The lot is accompanied by three photographs of Stamp as Zod.

Estimate. £4,000 - 6,000

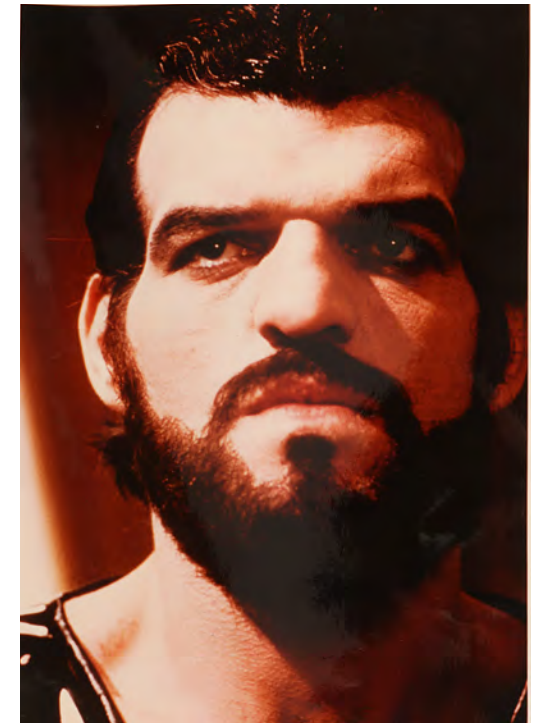

412
Non's (Jack O'Halloran) Thigh Boots M
Superman II (1980)

Non's (Jack O'Halloran) thigh boots from Richard Lester's superhero sequel Superman II. Kryptonian villain Non wore his boots throughout the film, including during his expulsion from Krypton and his confrontations with Superman in Metropolis and the Fortress of Solitude. Non also wore his boots during his relatively brief appearance in the first film of the franchise, Superman, with which this sequel was filmed back-to-back.

The dark brown laceless boots have a pointed protruding front collar, a tan leather interior and a vinyl outer layer. Each boot has a vertical 25 cm zipper that runs from the arch to mid-calf. The vamp and shaft of the boots feature vertical and diagonal linear seams. The boots have a broad round toe and a 6 cm platform sole, adding further height to O'Halloran's 6' 6" frame.

On both the toe box of the left boot and the instep of the right boot is a stitched 4 cm oval leather adornment. A stitched label inside the left boot features the name "J. O. HALLORAN". There is a 3 cm lateral tear in the vinyl at the top of the zipper of the right boot and the pair shows further signs of production wear, but are otherwise in good condition. Also included in the lot is a photograph of O'Halloran as Non.

Estimate. £4,000 - 6,000



Moviestore / Shutterstock

413
 Superman's (Christopher Reeve) Screen-Matched
 Synthetic Kryptonite Crystal Ω
Superman III (1983)

Superman's (Christopher Reeve) screen-matched synthetic Kryptonite crystal from Richard Lester's superhero sequel Superman III. Gold-colour residue and fracturing on its spike screen-match this crystal to the scene where Gus Gorman (Richard Pryor) gifted Superman synthetic Kryptonite while disguised as an Army general, making the superhero unusually selfish.

This large, multifaceted crystal is made of green cast resin with white gauze affixed on bottom for mounting to a base. It exhibits chipping to several points, exposing the resin, as well as adhesive residue and staining on the bottom from production use. Dimensions: 23 cm x 19 cm x 14 cm (9" x 7.5" x 5.5")

Estimate. £12,000 - 16,000



414
 Bullet-hit President Eisenhower Bust M
Superman II (1980)

A bullet-hit bust of former US President Dwight D. Eisenhower from Richard Lester's superhero sequel Superman II. This bust was used as set decoration in the White House when General Zod (Terence Stamp), Non (Jack O'Halloran) and Ursa (Sarah Douglas) broke in. Windows, walls and other pieces of furniture were caught in the crossfire as the US military and presidential bodyguards attempted to shoot the three impervious Kryptonians.

The heavy weight bust, created by Academy Award winning special effects designer Derek Meddings, is made of cast plaster over woven mesh. It is painted white with grey lines to resemble marble, and features three "bullet" holes and a destroyed nose with exposed cables, which once operated the remote controlled special effects explosive squibs rigged underneath the surface. These wires are visible at the back of the head and have been pinned with staples to keep them hidden. Dimensions: 60 cm x 43 cm x 29 cm (23 1/2" x 13" x 11 1/2")

Estimate. £4,000 - 6,000

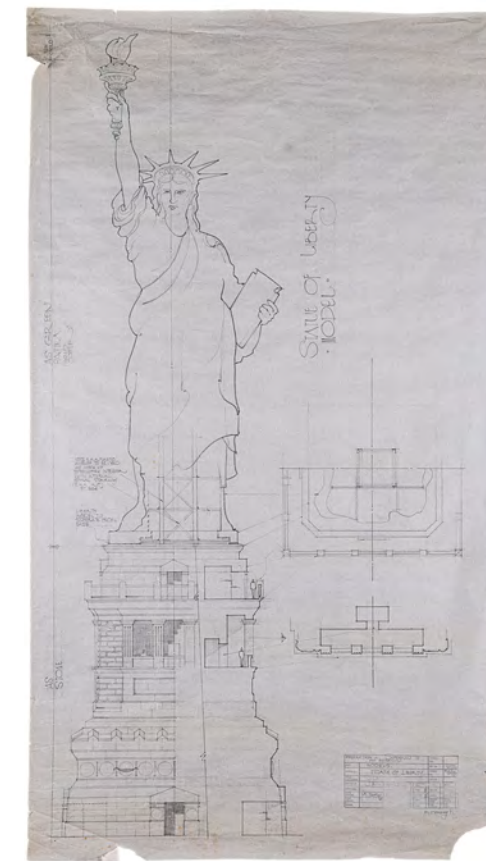

135 cm (53 1/4")

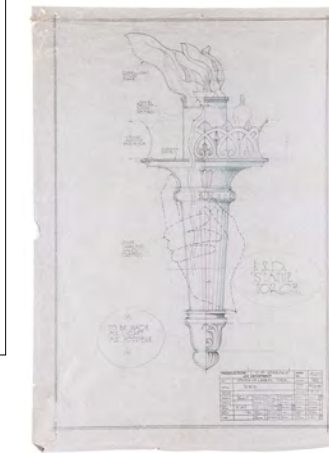

76 cm (30")

415
 Model Miniature Statue of Liberty and Pair of
 Hand-drawn Pencil Production Designs M
**Superman IV: The Quest For Peace (1987) &
 Little Shop Of Horrors (1986)**

A miniature model Statue of Liberty and a pair of production designs from the production of Frank Oz's sci-fi musical comedy Little Shop of Horrors, and Sidney J. Furie's superhero sequel Superman IV: The Quest for Peace. In the latter movie, Nuclear Man (Mark Pillow) stole the Statue of Liberty and attempted to destroy it during his first fight with Superman (Christopher Reeve). The statue was originally designed and sculpted for a scene in Little Shop of Horrors, in which the ever-growing plant Audrey II climbed the statue as she took over New York City. However, the scene was cut and the statue was revamped and repurposed for Superman IV.

The statue was designed by Little Shop of Horrors art director Stephen Spence and was sculpted by Peter Voysey. The body is made primarily of fibreglass and the torch is resin with cast-iron detailing around the flame. The statue is painted green and is intentionally distressed to look weathered. It has some minor staining and cracking to the crown.

Both production designs are rendered in pencil and ink and drawn by model art director John Fenner. One depicts the torch, is attributed to the Little Shop of Horrors production, and is dated "15 Oct 85". The other depicts the statue in its entirety, is attributed to Superman IV, and is dated "19 Sept 86". The designs are rolled for storage and have some minor staining and wear to the edges. Dimensions (statue): 48 cm x 65 cm x 189 cm (19" x 25 1/2" x 74 1/2")

Special shipping required; see special shipping notice in the Buyer's Guide.

Sold without copyright; see copyright notice in the Buyer's Guide.

Estimate. £4,000 - 6,000



189 cm (74.5")



416
 Set of Sweeney Todd's (Johnny Depp) Hero Razor Blades M
Sweeney Todd: The Demon Barber Of Fleet Street (2007)

A set of Sweeney Todd's (Johnny Depp) hero razor blades from Tim Burton's musical horror Sweeney Todd: The Demon Barber of Fleet Street. After a decade and a half of exile, Todd (Johnny Depp) returned to Fleet Street and used his razors to cut the throats of his victims. All the razors are notably seen during the "My Friends" musical number.

This lot comprises a set of seven razors, one for each day of the week, designed by prop master David Balfour. Each stainless steel blade features a unique bas-relief design on its handle, based on illustrations by William Blake. After sculptor Dick George created the prototypes, Burton selected two of the seven razors to be used as Todd's primary hero razors. The first of the hero designs is a female figure, with an upturned face and whose hair flows around her body, and the second depicts a mother and child. The razors exhibit areas of rusting from age. Dimensions (each razor): 19 cm x 3 cm x 1.5 cm (7 1/2" x 1 1/4" x 3/4")

Estimate. £20,000 - 30,000



417
 Team America Hummer H2
 Large-Scale Model Miniature us
Team America: World Police (2004)

A light-up large-scale Team America Hummer H2 model miniature from Trey Parker's action comedy Team America: World Police. Team America deployed a Hummer while chasing enemies through Egypt.

This Hummer H2 model consists of fibreglass over a steel frame with four Kenda Turf Rider lawn mower tires, a patriotic paint theme, a hood that opens to form a ramp, resin rockets and thrusters, and emergency lights activated by two switches underneath. It exhibits scuffing; peeling; sticky residue; and numerous loose or absent parts including unsecured lights, one missing missile, unattached guns, and a reattached licence plate. Various separate parts are also included. Dimensions: 183 cm x 86.5 cm x 76.5 cm (72" x 34" x 30")

Contains electronic components; see notice in the Buyer's Guide.

Special shipping required; see notice in the Buyer's Guide.

Estimate. £6,000 - 8,000



418
 Donatello's (Corey Feldman/Jim Raposa) Stunt Head Ω
Teenage Mutant Ninja Turtles III (1993)

Donatello's (Corey Feldman/Jim Raposa) stunt head from Stuart Gillard's action-adventure sequel Teenage Mutant Ninja Turtles III. All Effects Company was responsible for the creation of the animatronic turtle heads for this film, and there are significant differences between their heads and those made by Jim Henson's Creature Shop for the previous two movies. All Effects' heads feature a thinner bandana, a longer neck seam and larger, more defined spots applied to the skin.

The Donatello head is made from layers of latex reinforced by a jute base and adhered to green spandex. It features custom-made eyes, cast resin teeth and gums, and a purple fabric bandana. Since production, the interior has been filled with PU foam and expanding foam, and the head is fixed to a short white tube at the base, allowing it to be attached to a black display stand and a circular wooden base. Filling the head has helped retain its shape and may have been implemented for promotional purposes. Accompanying this lot is a spare screen-used purple mesh bandana which exhibits glue remnants and fading. Dimensions: 39 cm x 28 cm x 51 cm (15 1/2" x 11" x 20")

Estimate. £4,000 - 6,000



This jacket was worn by
Arnold Schwarzenegger in
"Terminator 2: Judgment Day".

It is the authentic article,
one of many that he wore
(due to the varying stages
of deterioration required in
the costume)

Another was recently auctioned
in Texas as a charity item
and brought in a winning
bid of over \$3000.

Good luck.
Linda Hamilton
2 August 1991



419

T-800's (Arnold Schwarzenegger) Bullet-Riddled Jacket with Handwritten
Linda Hamilton Letter of Authenticity  **Terminator 2: Judgment Day (1991)**

The T-800's (Arnold Schwarzenegger) bullet-riddled jacket from James Cameron's sci-fi action sequel Terminator 2: Judgment Day with a Letter of Authenticity handwritten by Linda Hamilton. The T-800 wore his iconic leather jacket throughout the film, including when it took heavy fire from the police in a teargas-filled hallway of the Cyberdyne Systems building. There are shots in the film that likely feature this exact jacket based on the squib holes and other markings; however, the detail visible onscreen is not clear enough to establish the screen-match conclusively.

This black leather jacket was originally purchased at a charity event in Long Beach, California, shortly after the film's release. It features metal zippers and snaps, bullet holes throughout, and black tape covering some of the holes. Its interior lining is affixed via fastening strips, rather than sewn in, to allow production to install and rig squibs.

This jacket is intentionally distressed by production with scuffs, tears, grime, stiffening leather, and tears throughout the lining, as well as tape residue from pieces of black tape placed over squib hits to alter the look for continuity or be blown open when a squib was detonated. Also included is a handwritten LOA from Hamilton.

Estimate. £20,000 - 30,000



420
T-800 Articulated Metal Endoskeleton Arm m
Terminator 2: Judgment Day (1991)

A T-800 articulated metal endoskeleton arm from James Cameron's sci-fi action sequel Terminator 2: Judgment Day. During the film's opening scenes, an army of T-800 terminators dominated the wasteland war zone of 2029 Los Angeles during the conflict between the artificial intelligence Skynet and the human resistance.

These genocidal machines were created by Cameron's long-time collaborator, Stan Winston, who originally helped bring one to life in 1984's The Terminator. Stan Winston Studio was tasked with creating numerous endoskeletons for the sequel's "Future War" opening sequence, including both cable-controlled puppets and static endoskeletons.

The arm has been separated at the elbow, and is made of cast metal with a chrome finish. It features flexible metal cables encasing plastic tubes, which run down the centre of the forearm and would have operated the movable fingers. The finger joints of the hand are still fully flexible but can no longer be posed or moved mechanically. The arm exhibits some scratches and minor tarnishing from production use and age. Dimensions: 54 cm x 10 cm x 9 cm (21 1/4" x 4" x 3 1/2")

Estimate. £30,000 - 50,000





421
Autographed Terminator (Arnold Schwarzenegger) Jacket Ω
Terminator 3: Rise Of The Machines (2003)

A Terminator jacket autographed by Arnold Schwarzenegger from Jonathan Mostow's sci-fi action sequel Terminator 3: Rise of the Machines. The Terminator wore his signature motorcycle jacket throughout the film.

Designed by Tony Nowak Studio and tailored specifically for Schwarzenegger, this black full-grain soft leather motorcycle jacket features a unique patina that cannot be replicated on other leather jackets, as well as padding on the arms and shoulders, a full-zip front fastening, four pockets, a belt, and laced sides. The upper left breast is signed by Schwarzenegger in silver-colour ink and the inside bottom is embroidered "A.S. T-3 Original 18" in black thread. Some of the jacket's thread is fraying from production wear and age.

Estimate. £6,000 - 8,000

422
John Connor's (Christian Bale) Battle Costume Ω
Terminator: Salvation (2009)

John Connor's (Christian Bale) battle costume from McG's action sci-fi sequel Terminator Salvation. Connor wore his costume during the opening sequence as he and Resistance soldiers attacked a prominent Skynet base.

The costume comprises a brown leather bomber jacket (size XL) with a metal zip, metal buckles at the waist and neck, and a red sash attached to the left arm; a nylon harness complete with rope, crampons and canvas bags containing resin ammunition magazines; a black cotton T-shirt (no size marked); a pair of camouflage trousers (no size marked) with built-in plastic kneepads, plastic buttons and metal buckles on the waist; a pair of black boots (UK 11) made of rubber and canvas with lace-in boot zips affixed by leather laces; a pair of fingerless leather gloves with knuckle padding; a black nylon leg holster with two blocks decorated to resemble C-4 explosives; a black nylon wrist holster with a metal knife and plastic sheath attached; and a green nylon leg holster holding a rubber stunt handgun. The lot also includes a wooden rod decorated to resemble a stick flare, and a rubber stunt rifle with a rubber sight fixed to the side via plastic zip ties and a green canvas strap. Dimensions (rifle): 89 cm x 30 cm x 10 cm (35" x 12" x 4")

Restricted ownership; see replica firearm notice in the Buyer's Guide.

Estimate. £8,000 - 12,000



423
Leatherface's (Dan Yeager) Screen-matched Hero Chainsaw Ω
Texas Chainsaw 3D (2013)

Leatherface's (Dan Yeager) screen-matched hero chainsaw from John Luessenhop's slasher sequel Texas Chainsaw 3D. Leatherface used chainsaws throughout the film to terrorise Heather (Alexandra Daddario) and her friends. This is the second one he used, and it matches several scenes through distinctive marks on the guide bar.

It is a STIHL petrol-powered chainsaw, which has been repainted and heavily distressed by production, with scuffs, scratches and stage blood along the guide bar and engine. Dimensions: 110 cm x 27 cm x 30 cm (43 1/4" x 10 3/4" x 11 3/4")

Special shipping required; see special shipping notice in the Buyer's Guide.

Contains mechanical components; see mechanical notice in the Buyer's Guide.

Estimate. £8,000 - 12,000

424
Toby the Tram Engine Display M
Thomas The Tank Engine (T.V. Series, 1984 - 2022)

A Toby the Tram Engine display from the long-running children's television show Thomas the Tank Engine & Friends. Toby was based on a J70 tram engine, and his main function was to shuttle workers to and from the quarry.

The model is made primarily of resin and acrylic and is painted to look like it features wood panelling. It has metal wheels and a small motor inside, and sits on a custom-made display featuring a small section of track and gravel.

A level of sympathetic restoration has been undertaken to restore it to its current condition. The model was taken apart so that glue and previous repairs could be tidied. There remain some general signs of use, including a missing windowpane at the back, paint wear and cracks along its grey skirting, and a broken front-left doorway. The cowcatcher is a replacement piece. Dimensions (tram): 22 cm x 10 cm x 14 cm (8 3/4" x 4" x 5 1/2")

Contains electronics; see electronics notice in the Buyer's Guide.

Contains mechanical components; see mechanical notice in the Buyer's Guide.

Estimate. £8,000 - 12,000





425
Full-Size FAB 1 Rolls-Royce Bonnet Ornament M
Thunderbirds (T.V. Series, 1965 - 1966)

A FAB 1 Rolls-Royce bonnet ornament from Gerry and Sylvia Anderson's puppet animation television series Thunderbirds. The ornament, known as "The Spirit of Ecstasy" sat atop the bonnet of Lady Penelope's Rolls-Royce saloon car Fab 1. It was used during close-up shots and where a 1:1 scale reference was required, such as when the front-mounted machine guns appeared from the grill, and for Parker's perspective as he drove towards Creighton-Ward Manor.

The ornament, designed by Charles Robinson Sykes, depicts a graceful kneeling woman with billowing wing-like sleeves leaning forwards as if in flight. The kneeling version of the ornament was designed for the Rolls-Royce Silver Dawn, Phantom IV and Silver Wraith to allow the driver a clearer view over the bonnet.

It is made from a chrome alloy and is attached to a cap which has been threaded on the inside to allow it to be mounted to the front of a car radiator housing. The ornament shows mild tarnishing from age. Dimensions: 11.5 cm x 10 cm x 8 cm (4 1/2" x 4" x 3")

Estimate. £3,000 - 5,000

426
Peter Nelson Collection: Full-Size FAB 1 Rolls-Royce Radiator Cover M
Thunderbirds (T.V. Series, 1965 - 1966)

A FAB 1 full-size Rolls-Royce radiator cover from the production of Gerry and Sylvia Anderson's puppet animation television series Thunderbirds. This radiator cover was made by the production for use on a full-size version of Lady Penelope's Rolls-Royce saloon car FAB 1. It was used during close-up shots and where a 1:1 scale reference was required, such as when the front-mounted machine guns appeared from the grill, and for Parker's perspective as he drove towards Creighton-Ward Manor.

It is made from a chrome alloy and features drill holes on the top where the 'Spirit of Ecstasy' ornament would attach, a hole at the front where the Rolls-Royce emblem would be affixed and two channels at either side where the grill would slide in and be bolted at the bottom. The cover shows mild tarnishing from age. Dimensions: 68 cm x 68 cm x 15 cm (26 3/4" x 26 3/4" x 6")

From the personal collection of Peter Nelson, previously displayed at his two museums, "The Cars of the Stars" and "The Bond Museum" in Keswick, Cumbria, until they closed in 2011.

Estimate. £2,000 - 3,000

427
Titanic Lifeboat Sign M
Titanic (1997)

A Titanic lifeboat sign from James Cameron's romantic disaster film Titanic. These signs were used as set dressing throughout the ship's interior and exterior. This sign and others like it can be seen on the sides of the lifeboats that were used to evacuate the sinking ship.

The resin sign features black raised text reading "S.S. Titanic" against a white textured background. A strip of clear acetate covers the remaining glue, spread along the sign's back to fasten it on set. The sign exhibits scuffing to the paintwork, revealing areas of the resin beneath, and there is a crack at the left end. Dimensions: 4.5 cm x 34.5 cm x 0.5 cm (1 3/4" x 13 1/2" x 1/4")

Estimate. £4,000 - 6,000



428
Synth Police Droid Costume Display M
Total Recall (2012)

A synth police robot suit display from Len Wiseman's sci-fi action remake Total Recall. Robots were used to police the territories of the United Federation of Britain and the Colony, and thousands were later used by Coahaagen (Bryan Cranston) as a Colony-invading army.

The suit comprises of a helmet with a black acrylic facemask; a jumpsuit; a chest guard; a pair of shoulder guards; a back guard; a waist cover; two arm pieces; a pair of gloves; leg armour; a pair of shin guards; and a pair of shoes. The majority of the armour is made of resin and hand-painted, with the waist cover made of brown-painted rubber. The jumpsuit is made from an elasticated black fabric and has white printed sections to replicate the appearance of mechanical components, which were enhanced with CGI in the finished film. Several sections - most notably on the chest - feature printed badges reading "Federal Police", with the unit's serial number and the words "Rapid Response Unit". The suit comes on a custom-built display stand. The suit has wear from production use, including some cracking to the rubber sections white paint markings on the jumpsuit, and a notable scratch in the middle of the facemask. Dimensions (displayed): 37.5 cm x 60 cm x 195 cm (14 3/4" x 23 1/2" x 76 3/4")

Special shipping required; see special shipping notice in the Buyer's Guide.

Estimate. £4,000 - 6,000

68 cm (26")



429
Screen-matched Animatronic Scorponok Head M
Transformers (2007)

A screen-matched animatronic Scorponok head from Michael Bay's sci-fi adventure Transformers. During the Decepticon Blackout's attack on the US SOCCENT Forward Operations Base in Qatar, his symbiotic counterpart Scorponok was ejected. As the surviving soldiers trekked through the desert to safety, Scorponok stalked the unit, eventually ambushing them outside a Bedouin village. This animatronic head screen-matches the moment when it peeked out of the sand to spy on the soldiers.

The arachnid robot Scorponok was brought to life on screen almost entirely using CGI; the only physical components created were the head and tail, built and operated by the talented crew at KNB EFX.

The head is constructed around a steel frame, with assorted hinges, springs and supports, and includes a variety of moving parts controlled with cables: two side panels can move in and out independently; a set of small and large mandibles can be made to pinch together; and the large forward-facing eyes can twitch left and right. Covering the surface are fibreglass panels decorated with rivets, scuffs and other distressing effects to make the head appear battle-worn.

It is painted metallic grey and faux bronze, with black accents and splatter effect to add to the aged appearance. "USAF 680360" is stencilled in black paint on the left panel. Sand from the desert-based film set is still present, and a patch of gaffer tape is adhered to the top of the head. This, most likely, was to achieve the trickling sand effect when the robot emerged from the ground. The lot comes with a custom-made mounting point to attach it to a secure wall surface. Dimensions: 68 cm x 60 cm x 71 cm (26" x 23" x 28")

Contains electronics; see electronics notice in the Buyer's Guide.

Estimate. £20,000 - 30,000

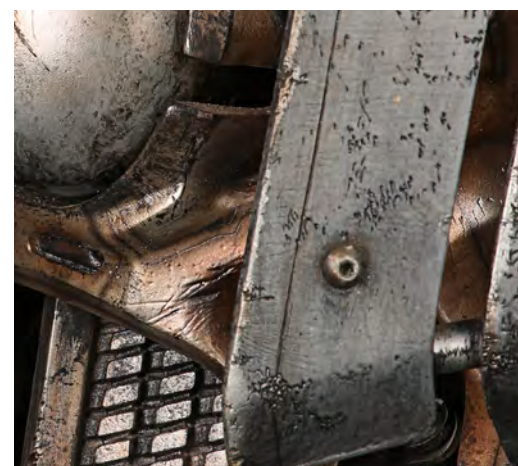

430
Full-size Hero Animatronic Scorponok Tail M
Transformers (2007)

A full-size hero animatronic Scorponok tail from Michael Bay's sci-fi action film Transformers.

After their base was attacked, the surviving soldiers trekked through the Qatari desert, tracked by the Decepticon known as Scorponok, who ambushed them outside a small village.

The arachnid robot was brought to life on screen almost entirely using CGI, with the only physical components being the head and tail. Special effects company KNB EFX created this piece especially for the scene in which the tail was recovered, then examined aboard an aircraft, where it momentarily reanimated and attacked the soldiers once again.

The full-size tail is built around multiple fastened steel segments, covered in similarly segmented fibreglass armour plating that is decorated with metallic grey paint, dressed with rivets, and given scuffs and an aged patina. The tip of the tail features pointed mandibles. Running through the centre of the rig are lengths of steel cable and rope that allowed the puppeteers to curl and twitch the tail on set. Dimensions: 350 cm x 85 cm x 85 cm

Contains electronics; see electronics notice in the Buyer's Guide.

Special shipping required; see special shipping notice in the Buyer's Guide.

Estimate. £10,000 - 15,000

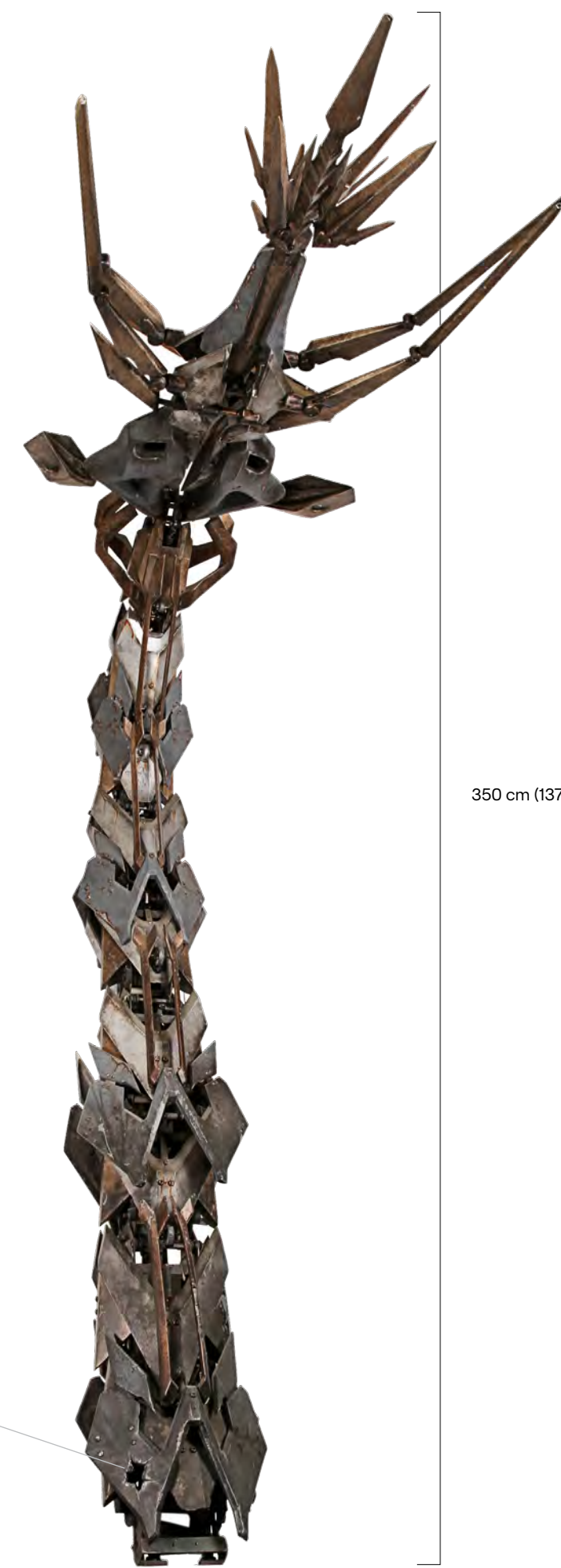

350 cm (137.8")



431
Sam (Quinn Lord) Mask and Costume Display us
Trick 'R Treat (2007)

A Sam (Quinn Lord) mask and costume display from Michael Dougherty's horror anthology *Trick 'r Treat*. Sam appeared in each story, including his own, "Sam," when he terrorized the ill-tempered Mr. Kreeg (Brian Cox).

This lot consists of a foam latex pumpkin-shaped mask hand-painted in muted orange tones with brown veins to appear flesh-like and lively and applied over rigid plastic skull for stability, as well as an orange fleece onesie with yellow burlap patches and beige hessian gloves. The mask features a hole from a shotgun blast above the right eye where Kreeg shot Sam, as well as stitch-like detailing around the mouth and left eye.

This lot comes mounted via metal poles in the feet to a custom-made faux stone display base with faux leaves. The burlap mask and Jack-O-Lantern lollipop held in opposite hands are replicas added to complete the display. Though the lot underwent sympathetic restoration following production, it still exhibits cracking and flaking foam on the mask, separating from the body, and tears in the toes of the onesie. As this display ships from Los Angeles, shipping should be arranged with Propstore prior to bidding. Dimensions (displayed): 146.25 cm x 45.75 cm x 35.75 cm (57.5" x 18" x 14")

Special shipping required; see notice in the Buyer's Guide.

Estimate. £30,000 - 50,000



432
Hector's (Eric Bana) Armour M
Troy (2004)

Hector's (Eric Bana) armour from Wolfgang Petersen's historical epic Troy. Trojan prince Hector wore his armour as he battled the combined armies of Greece, eventually duelling the legendary warrior Achilles (Brad Pitt).

Made from vinyl finished in gold-coloured paint, the armour comprises a helmet featuring an attached long plume; a chest plate decorated with ornate panels and patterns unique to this character; and a pair of greaves. Each component is lined with brown suede fabric with padding added to the shoulders of the chest plate. The interior of the chest armour is labelled "Hector #2", and the helmet and greaves are marked "Hector". The armour has been intentionally distressed to appear well worn.

Estimate. £5,000 - 7,000



433
Clarence (Christian Slater) and Alabama's (Patricia Arquette) Sunglasses M
True Romance (1993)

Clarence (Christian Slater) and Alabama's (Patricia Arquette) sunglasses from Tony Scott's romantic crime drama True Romance. Both wore their signature sunglasses throughout the film.

Clarence's plastic Elvis-style glasses are gold in colour, with amber lenses. Alabama's plastic sunglasses are light blue, with dark blue lenses. The lot is accompanied by two letters of authenticity from prop master Mike Blaze. Clarence's glasses are one of four pairs used for filming, while Alabama's are identical to the hero pair, but were back-ups and not used for filming. Dimensions (Clarence's glasses): 16.5 cm x 14.5 cm x 5.5 cm (6 1/2" x 5 3/4" x 2 1/4")

Estimate. £4,000 - 6,000



434
Clarence Worley's (Christian Slater) Screen-matched Licence and Bracelet M
True Romance (1993)

Clarence Worley's (Christian Slater) screen-matched licence and bracelet from Tony Scott's crime drama True Romance. Clarence wore his bracelet throughout the film and accidentally left his licence behind at the scene of Drexl's (Gary Oldman) murder. The licence matches the one seen held by Drexl through the creasing around its edges.

The licence is laminated, features a picture of Clarence and his personal information, and is held in a protective plastic case. The bracelet is metal and features Clarence's name. Dimensions (licence): 8 cm x 6 cm (3 1/4" x 2 1/4")

Estimate. £4,000 - 6,000



435
Alabama's (Patricia Arquette) Purse and License M
True Romance (1993)

Alabama's (Patricia Arquette) purse and licence from Tony Scott's romantic crime drama True Romance. Alabama's purse was seen on the floor of her hotel room as mobster Virgil (James Gandolfini) assaulted her for information.

The blue leather purse contains Alabama's laminated Florida driving licence. It was personally picked by director Scott, and the lot is accompanied by a letter of authenticity from property master Mike Blaze. The purse was the only one used on set and still has flecks of stage blood from the assault scene. Dimensions (purse closed): 8 cm x 11.5 cm x 2.5 cm (3 1/4" x 4 1/2" x 1")

Estimate. £3,000 - 5,000





436
Selene's (Kate Beckinsale) Pistols Ω
Underworld: Awakening (2012)

Selene's (Kate Beckinsale) pistols from Mans Marling and Bjorn Stein's action horror sequel *Underworld: Awakening*. Selene wielded Beretta 92FS as her trademark firearms, but she picked up a pair of STI GP6 pistols at the Antigen facility where she was held.

This lot consists of two resin STI GP6 pistols and two foam-modified Beretta 92FS Inox pistols. The STIs are engraved with the company logo on their sides, and the modified two-toned Berettas are painted black and silver-colour. Each handgun exhibits scratching and scuffing from production use, and the Berettas exhibit extensive adhesive residue and peeling paint from previously being mounted to a display. Dimensions (each): 51 cm x 33 cm x 5 cm (20" x 13" x 2")

Ownership may be restricted in some countries; see replica firearm notice in Buyer's Guide.

Estimate. £2,000 - 3,000



437
Selene's (Kate Beckinsale) PVC Catsuit M
Underworld (2003)

Selene's (Kate Beckinsale) PVC catsuit from Len Wiseman's fantasy-horror sequel *Underworld: Evolution*. Selene wore her signature catsuit throughout the film.

This custom-made black PVC catsuit features two leather-and-plastic buckle clips attached at the collar; a pair of elastic stirrups; a zip fastening down the front; and "Kate" handwritten inside in silver pen. It also exhibits intentionally distressed holes above the left knee and right wrist, which indicate that the costume was created for scenes set after Marcus (Tony Curran) attacked Selene on the boat, stabbing her in those locations. The seams display loose stitching from production use.

Estimate. £4,000 - 6,000



438
V's (Hugo Weaving) Belt of Knives \dagger
V For Vendetta (2005)

V's (Hugo Weaving) belt of knives from James McTeigue's dystopian drama *V for Vendetta*. V (Hugo Weaving) wore a belt of throwing knives throughout the film while working to bring down Britain's oppressive government - most notably during his final fatal confrontation with Creedy (Tim Pigott-Smith).

The wide, black leather belt features a silver-coloured metal buckle and 12 metal holster loops containing six permanently affixed knives. Each dense-rubber knife comprises a thin blade and a black-painted grip wrapped in gold-coloured cord. There are signs of tarnishing on the buckle and holster loops. Dimensions (each knife): 39 cm x 6.5 cm x 3 cm (15 1/4" x 2 1/2" x 1 1/4")

Estimate. £4,000 - 6,000



439
Van Helsing's (Hugh Jackman) Hero Hat M
Van Helsing (2004)

Van Helsing's (Hugh Jackman) hero fedora from Stephen Sommers' horror-adventure film *Van Helsing*. Monster hunter Van Helsing wore his signature headwear as he battled Count Dracula (Richard Roxburgh) and his minions.

This wide-brimmed fedora was custom made for the production by Tirelli, who produced two versions of the hero hat. This is the shorter-crown style, used for carrying, running and riding sequences. It is made from dark brown suede and leather, with intricate stitching on the main brim and a light brown trim around the band. The fedora is marked as size 59 on the interior, where "Van Helsing" is handwritten on a label. The hat has been lightly distressed and remains in excellent condition.

Estimate. £4,000 - 6,000



440
 Ray Ferrier's (Tom Cruise) Leather Jacket Costume M
War Of The Worlds (2005)

Ray Ferrier's (Tom Cruise) leather jacket costume from Steven Spielberg's sci-fi horror War of the Worlds. Ray wore this style of jacket throughout the film, and different jackets were used to demonstrate their gradual distressing as the action intensified. This particular jacket was likely created for the scene where Ray was captured and held inside the alien pod, through the rip that runs down the back left shoulder seam and its sleeves, which are two inches wider than the others made for production. The sleeves were widened to accommodate the excessive pulling by multiple characters to save Ray from the Alien's tripod's clutches.

The brown leather jacket is made by John David Ridge and features a label on the left interior pocket that reads "Mr. Tom Cruise, Big Sleeve". Also included are a blue T-shirt and a pair of dark blue jeans, (size 32), that have both been intentionally distressed to appear dirty and discoloured. "Ray 132-159" is handwritten in black pen inside both the T-shirt's neckline and the waistband of the jeans. This costume is accompanied by a production label that notes the scenes in which it was used.

Estimate. £6,000 - 8,000



441
 Cochise's (David Harris) Vest M
Warriors, The (1979)

Cochise's (David Harris) vest from Walter Hill's crime thriller The Warriors. Cochise and his fellow Warriors wore their gang vests throughout the film as they made their way across New York City to their base at Coney Island.

The brown faux leather vest is hand-labelled "Cochese" [sic] near the maker's label, and features a black geometric-patterned trim and five buttons on the front. After production, the vests had their original patches removed and were reused in other productions. The current patches are accurate copies based on costume designer Bobbie Mannix's original designs. Some of the synthetic leather has worn away in places, most notably around the arm holes.

Estimate. £10,000 - 15,000





442
Screen-matched Suck Kut Device
Wayne's World (1992)

A screen-matched Suck Kut device from Penelope Spheeris' comedy Wayne's World. Ron Paxton (Charles Noland) demonstrated his new hair-cutting invention on Wayne (Mike Myers) and Garth's (Dana Carvey) television show at the beginning of the film. It screen-matches the scene through imperfections and markings on the red nozzle.

This piece is made from resin and fibreglass in the form of a vacuum handle, with the words "Suck Kut" on the front. The main red handle is attached to a plastic hose that connects to a backpack unit with straps. This backpack unit is also plastic, and features two cylindrical tubes that are painted black, and features the name "Suck Kut", too. The nozzle has some cracks on each side and shows signs of repair. The device comes with a custom-made display featuring the film's title. Dimensions (displayed): 35.5 cm x 53.5 cm x 71 cm (14" x 21" x 28")

Estimate. £5,000 - 7,000



444
Wonder Woman's (Gal Gadot) Tiara
Wonder Woman (2017)

Wonder Woman's (Gal Gadot) tiara from Patty Jenkins' superhero film Wonder Woman. Queen Hippolyta (Connie Nielsen) gifted Diana her late aunt Antiope's (Robin Wright) tiara before Diana left the hidden island of Themyscira with Steve Trevor (Chris Pine). She continued to wear her tiara throughout the film as part of her signature Wonder Woman costume, on her quest to end the war in the outside world and stop Ares (David Thewlis).

The curved cast-resin tiara is finished in metallic gold with shades of black applied to create additional depth. It features a pointed section at the front decorated with a large star emblem at the centre, and the inside is lined with black faux suede. Presented on a custom display stand, the tiara displays minor marks on the lining, and the suede has begun to peel away slightly at the front. The lot is accompanied by a Warner Bros. certificate of authenticity. Dimensions (displayed): 15 cm x 15 cm x 21 cm (6" x 6 3/4" x 8 1/4")

Estimate. £15,000 - 25,000



Entertainment Pictures / Alamy Stock Photo

Clay Enos / Warner Bros / Kobal/Shutterstock

443
Lt. Schaffer's (Clint Eastwood) Nazi Uniform Jacket
Where Eagles Dare (1968)

Lt. Schaffer's (Clint Eastwood) Nazi uniform jacket from Brian G. Hutton's World War II film Where Eagles Dare. Schaffer wore his jacket while operating undercover as a Nazi officer, during a daring mission to rescue a US Army Brigadier General. Where Eagles Dare is widely considered one of the greatest war films of all time, and was one of the most popular movies released in 1968.

The grey jacket features a green-and-silver Nazi eagle patch on the right breast, rank insignia patches on the green collar, and an edelweiss flower patch on the right arm. The inside right pocket features an M. Berman Ltd costumier's label with "16076 C Eastwood" handwritten in faded blue ink. There is some wear to the rank patches on the collar.

Estimate. £6,000 - 8,000





446
 Deadpool's (Ryan Reynolds) Long
 Knuckle Blades Ω
X-Men Origins: Wolverine (2009)

Deadpool's (Ryan Reynolds) long knuckle blades from Gavin Hood's superhero prequel X-Men Origins: Wolverine. After being experimented on by Stryker (Danny Huston) and transformed into Weapon XI, Wilson (also named "Deadpool" by Stryker) battled Wolverine (Hugh Jackman) using a pair of long blades that extended from his knuckles.

These resin blades are painted silver to imitate metal. Each features a black rubber handle grip attached to a curved steel rod that fits between the knuckles and extends up the arm when held. The grips have the letters "R" and "L" painted on them in white. Both blades exhibit scuffs to the paintwork from production use. Dimensions (each): 74.5 cm x 7 cm x 7.5 cm (29 1/4" x 2 3/4" x 3")

Estimate. £4,000 - 6,000

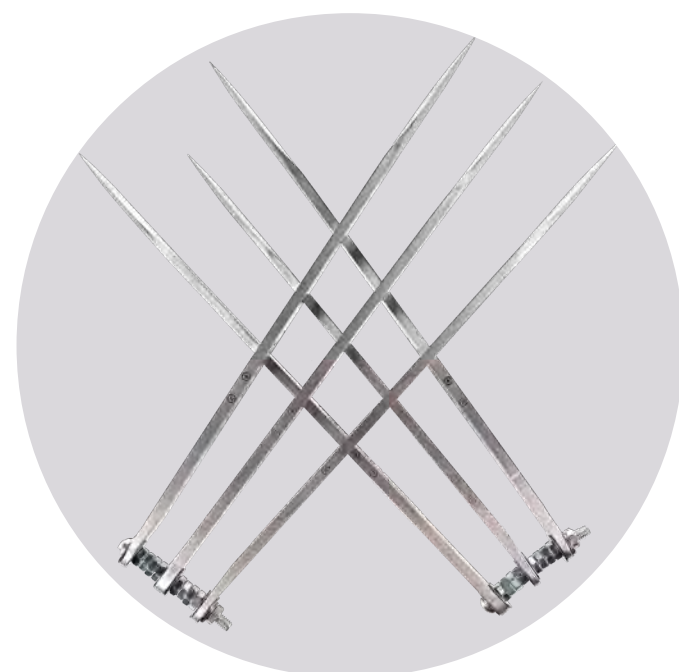

445
 Wolverine's (Hugh Jackman) SFX Aluminium Claws Ω
X-Men (2000)

Wolverine's (Hugh Jackman) SFX aluminium claws from Bryan Singer's superhero film X-Men. Wolverine deployed his signature adamantium claws throughout the film, including during flashbacks to the Weapon X tank and when Magneto (Ian McKellen) pulled the claws painfully far out from his hands.

These six aluminium claws were created by production and fitted into prosthetic arms for SFX, high-speed close-ups of Wolverine's blades coming through his skin and impacting objects, but ultimately unused in the final cut. Each claw blade features patterned debossing on the flat sides distinctive to both the train and flashback scenes. They are also uniquely longer than other Wolverine claws from throughout the franchise, with one blade shorter than the others for ejection purposes.

These claws are fastened together using bolts, washers, and hex nuts. Also included is a Certificate of Authenticity from FXSmith Inc. The blades exhibit scuffing from production use. Dimensions (each): 39.5 cm x 11.5 cm x 2.75 cm (15.5" x 4.5" x 2")

Blades were dulled by production.

Estimate. £8,000 - 12,000



447
 Hero Wolverine (Hugh Jackman)
 Claws Ω
Wolverine, The (2013)

A pair of hero Wolverine (Hugh Jackman) claws from James Mangold's superhero sequel The Wolverine. Wolverine used his retractable claws when he was forced to travel to Japan to fulfil the dying wish of an old friend.

This lot comprises two sets of extended aluminium claws attached to brown grips via curved metal rods. Designed to fit Jackman's hands, these claws were created for shots in which Wolverine's adamantium blades were fully extended, with the grip concealed in the palm. The claws are also polished and moulded by production to appear grooved from use. The claws come in a padded production carrying case featuring the film's title. Dimensions: 27 cm x 8 cm x 4 cm (10 3/4" x 3 1/4" x 1 1/2")

Estimate. £8,000 - 12,000





448
 Victoria's (Emily Blunt) George IV State Diadem
 Coronation Crown Ω
Young Victoria, The (2009)

Victoria's (Emily Blunt) George IV State Diadem coronation crown from Jean-Marc Vallee's historical drama *The Young Victoria*. Victoria wore the George IV State Diadem in the returning procession of her coronation.

A highly detailed recreation of the real George IV State Diadem that was worn regularly by queen regnant and consort since Queen Adelaide, this silver-colour metal crown features a purple velveteen inner lining, faux pearls and crystals embedded throughout, and a special paint applied to reduce the sparkle of the crystals for filming. Also included is a red velour pillow with gold-colour trimming and tassels, and a COA from Crowns and Regalia, the makers of the crown who resized it to specifically fit Emily Blunt. Dimensions (crown): 21.75 cm x 19.25 cm x 8.5 cm (8.5" x 7.5" x 3.25"); (pillow): 10" x 10" x 4.5" (25.5 cm x 25.5 cm x 11.5 cm)

Estimate. £20,000 - 30,000



Day 2

Lots 449 - 623.
Nov 4, 2022

Music lots can be viewed in the separate Music Treasures printed catalog or online catalog. Days 3 and 4 contain additional film and television lots.



Day 3

Lots 624 - 1083.
Nov 5, 2022



*Certain films and shows have Lots offered on more than one day of the Auction; see Index on page 681 for a complete listing of available Lots by film or show title



624
"Dawn of Man" Ape Mask **M**
2001: A Space Odyssey (1968)

A "Dawn of Man" ape mask from Stanley Kubrick's sci-fi epic 2001: A Space Odyssey. This mask was made for the "Dawn of Man" prologue sequence, renowned for its incredibly realistic make-up and facial appliances. This integral piece of movie history was constructed by the eminent Stuart Freeborn, whose astonishing work on 2001: A Space Odyssey led to him creating such popular movie characters as Yoda and Chewbacca in the Star Wars trilogy. Made of foam latex, the mask is displayed upon a clear plastic facial mould and comes with a silicon ape ear and was originally acquired directly from Stuart Freeborn. The mask shows degradation but, considering its age, remains in excellent condition. Dimensions: 28 cm x 18 cm x 17 cm (11" x 7" x 6 3/4")

Estimate. £2,000 - 3,000



626
Rare Promotional Lenticular Postcards, Premiere Ticket and Programmes **M**
2001: A Space Odyssey (1968)

Two rare lenticular postcards, a premiere ticket and screening programmes from the promotion of Stanley Kubrick's 2001: A Space Odyssey. The lenticular postcards were printed by Toppani for the Japanese Cinerama release in 1968. One design shows the wheel-shaped Space Station V, and the second card features astronauts on the lunar base. Completing the lot are a ticket and programme for the Gala European Premiere, dated "Wednesday, May 1st 1968"; an additional souvenir programme; and three newspaper clippings about the film. There are signs of wear to both programme covers, and the edge of one ticket is torn. Dimensions (each postcard): 14.5 cm x 10.5 cm (5 3/4" x 4 1/4"); (larger programme): 30.5 cm x 22.5 cm x 0.3 cm (12" x 8 3/4" x 1/4")

Estimate. £600 - 800



625
Stuart Freeborn Collection: Dawn of Man Prototype Mask and Mould **M**
2001: A Space Odyssey (1968)

A prototype mask and mould from Stanley Kubrick's sci-fi epic 2001: A Space Odyssey. Apes surrounded the Monolith during the opening "Dawn of Man" sequence. This lot originated from the collection of legendary make-up artist Stuart Freeborn. The foam-latex mask is hand-punched with faux hair and is a test for a "man-ape" character concept. Kubrick felt it would be problematic due to censorship issues and opted for a hairier "ape-man". The lot includes a plaster mould. The mask is stiff and brittle with light cracking. Dimensions (mask): 18 cm x 16 cm x 10 cm (7 1/4" x 6 1/4" x 4") Literature An image of this mask can be seen between pages 14 and 15 of Moonwatcher's Memoir: A Diary of 2001: A Space of Odyssey by Dan Ritcher, published by Carroll & Graf Publishers.

Estimate. £2,000 - 3,000



627
Jack Bauer's (Kiefer Sutherland) Jacket **Ω**
24 (T.V. Series, 2001 - 2010)

Jack Bauer's (Kiefer Sutherland) jacket from the action drama series 24. Bauer wore his jacket throughout Season 5, the critically-acclaimed season that earned the series five Primetime Emmy Awards, including Outstanding Drama Series and Outstanding Lead Actor in a Drama Series for Sutherland. This grey jacket features a denim exterior, a fleece lining with a hood, four front pockets, and a front enclosure with buttons and a zipper.

Estimate. £1,500 - 2,500



628
Donald Harris' (Robert Carlisle) ID Tag and Passes †Δ
28 Weeks Later (2007)

Donald Harris' (Robert Carlisle) ID tag and passes from Juan Carlos Fresnadillo's horror sequel 28 Weeks Later. Don wore his ID and used his passes when taking his children Tammy (Imogen Poots) and Andy (Mackintosh Muggleton) through District One. The plastic ID card features a picture of Don and his personal information and is attached to a metal clip. The three "Access All Areas" cards are blue, orange and green. The lot also includes an extendable metal chain that is worn on the belt. Dimensions (each card): 5.5 cm x 8.5 cm (2 1/4" x 3 1/4")

Estimate. £800 - 1,200



629
Stunt Spartan Costume M
300 (2006)

A stunt Spartan costume from Zack Snyder's historical epic 300. Led by King Leonidas (Gerard Butler), the outnumbered Spartan warriors wore their costumes throughout the film as they battled the invading Persian forces of King Xerxes (Rodrigo Santoro). The intentionally distressed costume comprises a fibreglass helmet with foam padding adhered to the cheek plates (labelled "#1 Tim Rigby"); a heavy red canvas cape (labelled "Rich Cetrone #4"); a pair of urethane bracers; a brown leather codpiece (labelled "5 Tim Connolly"); and a pair of urethane greaves (both labelled "E.Guilbault"). Remnants of stage blood are present on the helmet and greaves. The cape exhibits intentional holes and marks, and its colour is faded towards the bottom to create a worn appearance.

Estimate. £2,000 - 3,000



630
Battle-damaged Spartan Shield †Δ
300 (2006)

A battle-damaged Spartan shield from Zack Snyder's historical epic 300. Led by King Leonidas (Gerard Butler), the outnumbered Spartan warriors wielded their shields throughout the film as they battled the invading Persian forces of King Xerxes (Rodrigo Santoro). This battle-damaged version of the shield was likely used in the film's later sequences. The circular shield is made of fibreglass painted in shades of gold with a raised "V" shape. It is heavily distressed, featuring multiple lacerations, spear holes, stage blood and mud. Two nylon straps are hidden behind a leather patch on the back, alongside an additional handle wrapped in leather. Dimensions: 91 cm x 90 cm x 12 cm (35 3/4" x 35 1/2" x 4 3/4")

Estimate. £2,000 - 3,000



631
Captain-Style Spartan Helmet †Δ
300 (2006)

A Captain-style Spartan helmet from Zack Snyder's historical epic 300. Led by King Leonidas (Gerard Butler), the outnumbered Spartan warriors wore their helmets throughout the film as they battled the invading Persian forces of King Xerxes (Rodrigo Santoro). Approximately six major helmet sculptures were produced based on various named characters, with helmets of this style named for the Spartan Captain (Vincent Regan) given to background performers. Made of fibreglass, the helmet is painted to resemble bronze with brown leather lining the cheeks. The interior is padded with foam and labelled for stunt performer "Tim Rigby #1" in black ink. An additional label on the inside reading "204 Chad Stahelski" [sic] implies that assistant stunt coordinator Chad Stahelski may also have worn it. Lightly distressed to create a battle-worn appearance, the helmet displays noticeable chips to the fibreglass. Dimensions: 28.5 cm x 18.5 cm x 32 cm (11 1/4" x 7 1/4" x 12 1/2")

Estimate. £1,000 - 1,500



632
SFX Foosh Pistol M
6Th Day, The (2000)

An SFX Foosh pistol from Roger Spottiswoode's sci-fi action film The 6th Day. Various characters, including Adam Gibson (Arnold Schwarzenegger), used energy-emitting Foosh pistols throughout the film. The weapon was designed by the legendary Ron Cobb and this SFX gun combined calcium carbide and water to produce acetylene gas, which produced colourful flashes from the exhaust ports on the sides of the firearm when the trigger was pulled. The pistol is made of metal and features "FOSS-HARVESTER" on the left side and the serial number "1105" on the other. The pistol has wear from production use, most notably discolouration next to the exhaust ports on each side, paint wear, and a chip on the faux switch on the left. Dimensions: 25 cm x 6 cm x 15 cm (9 3/4" x 2 1/4" x 6") Restricted ownership; see replica firearm notice in the Buyer's Guide. Contains mechanical components; see mechanical notice in the Buyer's Guide.

Estimate. £800 - 1,200



634
David Norris' (Matt Damon) Costume †Δ
Adjustment Bureau, The (2011)

David Norris' (Matt Damon) costume from George Nolfi's sci-fi thriller The Adjustment Bureau. David wore his Loro Piana suit in several scenes as he and Elise Sellas (Emily Blunt) spent a day together. The costume consists of a navy blue woollen suit jacket (labelled "#1 DBL Damon Matt") and matching trousers ("#1 DBL Damon Matt"); a light blue shirt ("MD Nov 2009"); and a blue tie. The suit is accompanied by a production tag featuring information about the suit and the scenes it was used in.

Estimate. £1,500 - 2,500



633
Gigolo Joe's Stunt Suit M
A.I. Artificial Intelligence (2001)

Gigolo Joe's stunt suit from Steven Spielberg's sci-fi drama A.I. Artificial Intelligence. Gigolo Joe (Jude Law) wore his suit throughout the film, with various different shirts, as he evaded police and helped David (Haley Joel Osment) to find the Blue Fairy. The suit comprises a long coat and trousers made of grey taffeta fabric, to give the ensemble a metallic shimmer. The coat has three grey plastic buttons and the trousers have a metal zip and fastener. The garments are unmarked and show wear with slight fraying to the metallic threads throughout.

Estimate. £2,000 - 3,000



635
Pair of Bureau Portal Hats †Δ
Adjustment Bureau, The (2011)

A pair of Bureau portal hats from George Nolfi's sci-fi thriller The Adjustment Bureau. Adjustment Bureau agents wore hats to teleport via doors, and a large collection of these hats can be seen in the Bureau. The Biltmore® fedoras are "sage" green and "black oak" brown, and sized "59 - 7 1/2" and "60 - 7 1/2", respectively. Both have "The Adjustment Bureau" stamped in gold lettering on the leather sweatbands, and the brown hat has a decorative feather in its band.

Estimate. £800 - 1,200

636
No Lot

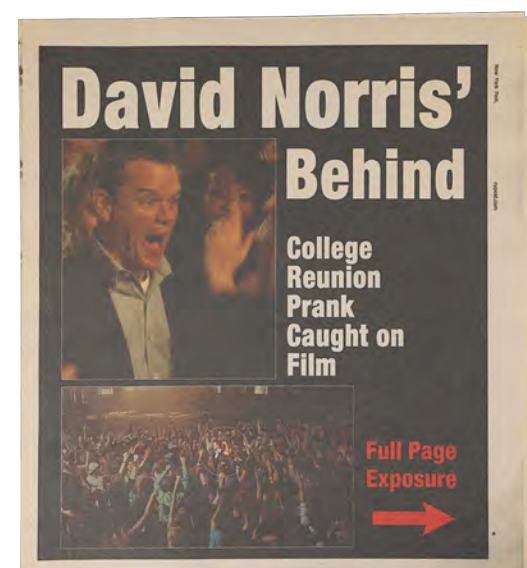

637
David Norris' (Matt Damon) Business Card, MetroCard, Newspaper Page and Campaign Pins †Δ
Adjustment Bureau, The (2011)

David Norris' (Matt Damon) business card, MetroCard, newspaper page and pins from George Nolfi's sci-fi thriller *The Adjustment Bureau*. Elise Sellas (Emily Blunt) wrote her phone number on the back of one of Norris' business cards; Norris used his MetroCard on the bus; The New York Post featured a story that torpedoed Norris' Senate-election campaign; and Norris' supporters wore pin badges at his rallies. The business card features Sellas' name and a phone number handwritten on the back, and the newspaper page features a photo of Norris and a headline about a college prank. Dimensions (newspaper page, folded): 30.5 cm x 28 cm (12" x 11")

Estimate. £800 - 1,200



638
Sydney Bristow's (Jennifer Garner) Jacket M
Alias (T.V. Series, 2001-2006)

Sydney Bristow's (Jennifer Garner) jacket from the sci-fi thriller series *Alias*. Sydney wore her jacket in the Season 1 episode "Doppelgänger" as she and Dixon (Carl Lumbly) broke into the vaccine plant in Badenweiler, Germany. The black leather Bebe jacket is size "M" and features a metal zip and beige stitching. It is accompanied by a certificate of authenticity from ABC Studios.

Estimate. £1,500 - 2,500

Propstore

Sell Your Posters

Star Wars: The Empire Strikes Back (1980)

Original Painted
Concept Artwork, 1980

sold for £53,125 (\$70,125) incl. bp



Achieve world record prices for your posters

Reach out for a free appraisal and valuation with our specialists



Email: consign@propstore.com
Phone UK Office: +44 (0) 1494 766485
Phone US Office: +1 818 727 7829

Scan QR code to visit propstore.com/sell



639
Kane's Scale-Double
Space Suit Gloves α
Alien (1979)

Kane's scale-double space suit gloves from Ridley Scott's sci-fi film Alien. Kane wore his gloves as part of his suit when he embarked on the surface of the moon with Dallas and Lambert. Ridley Scott's children, Jake and Luke, wore scaled-down spacesuits to double for the principal performers in certain shots in the sequence to make their surroundings look even larger and more imposing. This pair of thick brown foam gloves features large, oblong thumbs for better gripping capabilities and fastening strips applied throughout. The elastic lining inside the gloves is marked "Kane R" and "Kane B," respectively. The gloves exhibit some cracking and fraying in the foam, as well as stiffness from production.

Estimate. £2,000 - 3,000

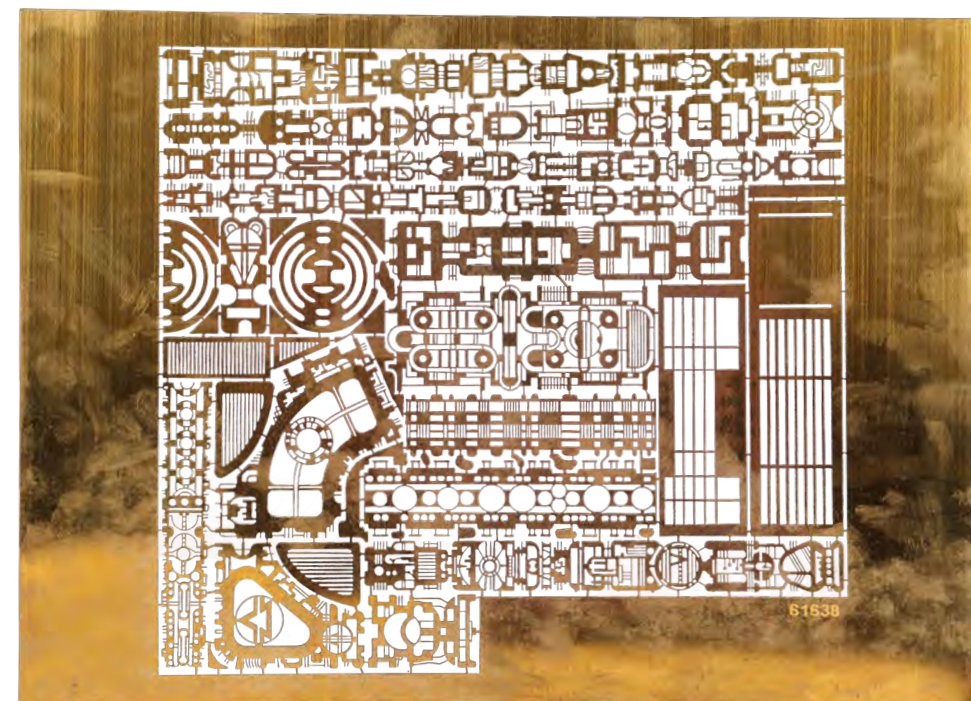

640
H.R. Giger Brass
Etching Space Suit Dressing \triangle
Alien (1979)

A premium laser-cut replica of an etching used as a stencil by Swiss surrealist artist H.R. Giger to create patterns in his paintings. It was also incorporated into designs seen in Ridley Scott's sci-fi horror Alien. This example was scanned directly from an original etching, and these intricate patterns were cut and incorporated into Dallas (Tom Skerritt), Kane (John Hurt) and Lambert's (Veronica Cartwright) spacesuits, which they wore while investigating a possible distress signal. The etching is on brass, and it is stamped "61638". There are signs of discolouration and fingerprint marks on the brass. Dimensions: 22.5 cm x 31 cm (8 3/4" x 12 1/4")

Estimate. £400 - 600

HARRY HARRIS ALIENS COLLECTION & ARCHIVE

This auction contains lots from The Harry Harris Aliens Collection and Archive, one of the largest collections of costumes, props and production material from 'Aliens' (1986). The collection has been extensively featured in magazines and on television and Harris was a key contributor to the 'Alien Quadrilogy' DVD set, and a Creative Consultant on the award-winning 'Alien Anthology' Blu-Ray set. The Harris Collection has also worked closely with several 20th Century Fox licensees to bring fresh and new Alien themed products to market. Harris Collection lots are identified as such in the title.



641
Harry Harris Collection: H.R. Giger
Autographed and Numbered
"Pilot in Cockpit" Print μ
Alien (1979)

An autographed and numbered "Pilot in Cockpit" print by Swiss surrealist artist H.R. Giger. Giger won an Academy Award® for his work with the visual effects team on Ridley Scott's Alien. The print features the iconic image of "The Pilot" dead in its cockpit, which Giger produced in 1978. It has been autographed in the bottom right corner, and numbered out of 1,000 in the bottom left, although the exact number is not clear. Dimensions: 59 cm x 49.5 cm (23 1/4" x 19 1/2")

Estimate. £300 - 500



642
Harry Harris Collection:
H.R. Giger Erotomechanics
Portfolio and Three Prints μ
Aliens (1986)

Three signed prints and a portfolio from Swiss surrealist H.R. Giger. The three prints feature Giger's distinct style of erotic "biomechanical" art. Designs such as these contributed to the iconic and horrific style of the xenomorph. Each has been hand-numbered (two "203/300" and one "75/300") and hand-signed by Giger himself. The prints come in a large red portfolio labelled "H.R. Giger Erotomechanics" on one side. The prints have some wear in places and the folder has scuffing and minor tears on the outside. Dimension (portfolio): 72 cm x 104 cm x 1.5 cm (28 1/4" x 41" x 1 1/2")

Estimate. £400 - 600



643
Harry Harris Collection: H.R. Giger Autographed Tarot Cards Proof Print **M**
Aliens (1986)

A page of tarot card proofs autographed by Swiss surrealist artist H.R. Giger. Giger was invited by the Swiss occultist Akron to create a set of tarot cards, for which he repurposed some of his existing work. The print features the 22 Major Arcana card images with their titles in German, and Giger has signed his autograph in silver pen in an empty square at the bottom of the page. The reverse of the page features the design for the card backs. The page has been torn from a larger book and features a rough edge down one side. It has been rolled for storage. Dimensions: 87.5 cm x 55 cm (34 1/2" x 21 3/4")

Estimate. £300 - 500



644
Harry Harris Collection: Pair of Large "Ugly" H.R. Giger Exhibition Invitations **M**
Aliens (1986)

A pair of large invitations to an "Ugly" H.R. Giger exhibition. These poster-sized invites feature the word "Ugly" on one side in Giger's iconic "biomechanical" style and information in German about the event on the 13th September, 1979. The invitations are rolled for storage. Dimensions (each): 50 cm x 68 cm (19 3/4" x 26 3/4")

Estimate. £200 - 300



645
Crashed Dropship Missile Pod **M**
Aliens (1986)

A dropship missile pod from James Cameron's sci-fi sequel Aliens. The dropship had missile pods attached to the tips of its wings, before it crashed while attempting to rescue the Colonial Marines on LV-426. The pod is made primarily of resin around a foam-and-metal core. It is broken into several pieces and features prominent damage as a result of being crashed during production. Dimensions (largest section): 66 cm x 37 cm x 40 cm (26" x 14 1/2" x 15 3/4")

Estimate. £3,000 - 5,000



646
Harry Harris Collection: Model Miniature Dropship Weapons Pod **M**
Aliens (1986)

A model miniature dropship weapons pod from James Cameron's sci-fi sequel Aliens. The pod was attached to the side of the Colonial Marines' dropship before it crashed on LV-426. The pod is made of fiberglass around a biscuit-foam core and is painted to look like metal. It features painted warning signs and serial numbers. The pod has wear from use, including chipping to the fiberglass, and unpainted sections where its missiles were previously housed. Dimensions: 21.5 cm x 14.5 cm x 16 cm (8 1/2" x 5 3/4" x 6 1/4")

Estimate. £1,500 - 2,500



53.5 cm (21")

22 cm (8.75")

647
Dropship Missile **M**
Aliens (1986)

A dropship missile from James Cameron's sci-fi sequel Aliens. The dropship used by Ripley (Sigourney Weaver) and the Colonial Marines to land on the planet LV-426 was armed with dozens of missiles. The missile is made of resin and is painted to look like metal. It has some adhesive remnants and wear to the paint where it was previously held in the model miniature dropship. There is also some staining and discolouration. Dimensions: 53.5 cm x 14 cm x 14 cm (21" x 5 1/2" x 5 1/2")

Estimate. £2,000 - 3,000

648
Model Miniature
Dropship Missiles **TD**
Aliens (1986)

Model miniature dropship missiles from James Cameron's sci-fi sequel Aliens. The dropship used by Ripley (Sigourney Weaver) and the Colonial Marines to land on the planet LV-426 was armed with dozens of missiles. The missiles are made of resin, painted predominantly white and are glued together. There are some markings to the paint where they were previously attached to other missiles. Dimensions: 22 cm x 2.5 cm x 1 cm (8 3/4" x 1" x 1/2")

Estimate. £400 - 600



649
Harry Harris
Collection: Sgt. Apone's
(Al Matthews) Flak Jacket **M**
Aliens (1986)

Sgt. Apone's (Al Matthews) flak jacket from James Cameron's sci-fi sequel Aliens. Colonial Marines wore flak jackets as part of their uniform, although Apone's was not seen in the final cut of the film. Flak jackets are padded and weighted with materials to protect the wearer from shrapnel and other lower-velocity projectiles. The green jacket features Apone's name and rank patches on the right chest, and US flag and USCM patches on the left chest. The jacket zips up at the front. It is size "large" and features an instruction label in the collar.

Estimate. £1,000 - 1,500



650
Harry Harris Collection: USCM Neck Armour Piece **M**
Aliens (1986)

A USCM neck armour piece from James Cameron's sci-fi sequel Aliens. Legendary armourer Terry English made the Marine armour for the film. The armour originally included neck guards like this but these were eventually unused, potentially due to the discomfort caused to the actors. It is made of aluminium and is painted with forest camouflage. It has foam padding and a green strap. A small arrow is hand-drawn on the foam, indicating the direction of wear.

Estimate. £300 - 500



652
Four Pulse Rifle Shells, Pulse
Rifle Tag and Dropship Crew Patch **M**
Aliens (1986)

Four pulse rifle shells, a pulse rifle tag and a dropship crew patch from James Cameron's sci-fi sequel Aliens. Colonial Marines used pulse rifles as their primary weapons and the dropship crew wore "Victory by Wings" patches on their flight suits. Each shell is a spent blank, with the words "45 auto" and "blank" stamped on its base. The force of detonation has caused a fanning effect around the top. The patch has been intentionally distressed to look well-worn. The plastic rifle tag has a leather loop and information about the rifles. Dimensions (patch): 10 cm x 10 cm (4" x 4")

Estimate. £400 - 600



651
Harry Harris Collection: Acheron Colony Badge **M**
Aliens (1986)

An Acheron Colony badge from James Cameron's sci-fi sequel Aliens. Colonists in Hadley's Hope, including administrator Al Simpson (Mac McDonald), wore badges on their shirts in the special edition of the film. The acrylic badge features the Weyland-Yutani Corp logo and the name of the colony. The back has a metal pin. Dimensions: 3.5 cm x 9 cm x 0.5 cm (1 1/2" x 3 1/2" x 1/4")

Estimate. £300 - 500



653
Harry Harris Collection: USS Sulaco Cargo Bay Sign **M**
Aliens (1986)

A USS Sulaco cargo bay sign from James Cameron's sci-fi sequel Aliens. Signs were seen on many of the walls of the Sulaco's cargo bay. The circular card sign has "Airway 7D" printed in black on it. It has some minor staining and discolouration, and a couple of small pinholes at the top. Dimensions: 38 cm x 38 cm (15" x 15")

Estimate. £600 - 800

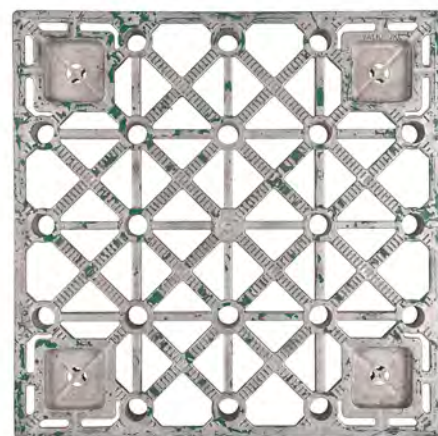

654
Harry Harris Collection:
Full-size USS Sulaco Floor Tile [M](#)
Aliens (1986)

A full-size USS Sulaco floor tile from James Cameron's sci-fi sequel Aliens. This style of tile was primarily used on the Sulaco hangar bay set, but was also used in the atmosphere processor lift. The tile is made of rigid green plastic and is spray-painted silver. The silver paint has worn away in places. Dimensions: 42.5 cm x 42.5 cm x 3 cm (16 3/4" x 16 3/4" x 3")

Estimate. £600 - 800



656
Hadley's Hope Desk Lamp [Ω](#)
Aliens (1986)

A Hadley's Hope desk lamp from James Cameron's sci-fi sequel Aliens. Desk lamps were used around the terraforming colony of Hadley's Hope, and in the Med Lab as Ripley (Sigourney Weaver) put Newt (Carrie Henn) to bed. The lamp features a bulb on a long metal arm, which can be adjusted on a pivot above the base. It illuminates via a standard U.K. wall plug. It exhibits wear from production use and age, including paintwork scuffing and scratches, and rusted metal. Dimensions (fully extended): 25 cm x 25 cm x 92 cm (9.75" x 9.75" x 36.25") Contains electronics; see electronics notice in the Buyer's Guide.

Estimate. £1,200 - 1,800



655
Harry Harris Collection:
Atmosphere Processor Set Dressing [M](#)
Aliens (1986)

A piece of set dressing from the atmosphere processor in James Cameron's sci-fi sequel Aliens. The piece is made from the back panel of a vintage television, and similar pieces are seen on the walls of the processor and in Newt's (Carrie Henn) hideaway. The piece is made of plastic and features a Weyland-Yunati sticker and two smaller silver stickers. It has some paint wear and chips. Dimensions: 64 cm x 66 cm x 31 cm (25 1/4" x 2 1/2" x 12 1/4")

Estimate. £800 - 1,200



657
Harry Harris Collection:
Acheron Colony Child's Tricycle [M](#)
Aliens (1986)

An Acheron Colony child's tricycle from James Cameron's sci-fi sequel Aliens. Children were playing with a tricycle in the halls of the main colony building in the Special Edition. The tricycle is plastic and painted orange. It was repainted after the production and has since been sympathetically restored. A Weyland-Yunati Corp plaque is adhered to the front. The wheels are black and the front wheel has black tape over the tread. The seat is no longer present. The tricycle has some paint wear and some minor cracking. The plaque was previously screwed to the front but is now stuck with tack. Dimensions: 98 cm x 52 cm x 53 cm (38 1/2" x 20 1/2" x 20 3/4")

Estimate. £800 - 1,200



658
Harry Harris Collection:
Model Miniature Colony Building [M](#)
Aliens (1986)

A model miniature colony building from the production of James Cameron's action sci-fi sequel Aliens. Model buildings were used throughout the film to create the set of Hadley's Hope, a terraforming and mining colony on the planetoid LV-426. Miniature scale buildings were used when the U.S. Colonial Marines arrived in their dropship and drove their APC vehicles through the desolate town. The model miniature building is made from resin with a plasticard roof dressed with plastic rods and blocks. Several sections on this model were constructed using a method known as kitbashing where the designer would take pieces from other models and toys - most notable models used are a Star Wars Snowspeeder, Millennium Falcon and a Space: 1999 Eagle transporter. Dimensions: 34 cm x 33 cm x 10 cm (13 1/2" x 13" x 4")

Estimate. £2,000 - 3,000



660
Harry Harris Collection:
A Pair of USS Sulaco Hangar Model Miniatures [M](#)
Aliens (1986)

A pair of model miniatures from the USS Sulaco hangar in James Cameron's sci-fi sequel Aliens. These were made for the climactic battle between Ripley (Sigourney Weaver) and the alien queen, a sequence partly realised on a miniature set. The miniatures - a crate and crane-like device - are made of resin and painted yellow. They have been intentionally distressed to appear well used, and are accompanied by a spring wrapped in foil to look like metal tubing. The pieces have wear from production use, including cracks, paint wear and minor dents. Dimensions (largest miniature): 22 cm x 17 cm x 34 cm (8 3/4" x 6 3/4" x 13 1/2")

Estimate. £800 - 1,200



659
Harry Harris Collection:
Pair of Model Miniature USS Sulaco Vidfones [M](#)
Aliens (1986)

A pair of model miniature USS Sulaco vidfones from James Cameron's sci-fi sequel Aliens. Vidfones were seen in the hangar bay of the Sulaco and were made for the miniature set built for the climactic fight between Ripley (Sigourney Weaver) and the alien queen. The vidfones are made primarily of resin with wooden screens painted silver. The screens and keypads are not attached. There are some chips and wear from where the items adhered to the set. Dimensions (screens): 11 cm x 15.5 cm x 2 cm (4 1/4" x 6" x 3/4")

Estimate. £800 - 1,200



661
Harry Harris Collection:
Model Miniature USS Sulaco Cargo Container [M](#)
Aliens (1986)

A model miniature USS Sulaco cargo container from James Cameron's sci-fi sequel Aliens. Ripley (Sigourney Weaver) smashed the alien queen into a stack of containers during the climactic fight in the Sulaco hangar bay. The container is made of vacuum-formed plastic and is broken into two sections and remains fragile as a result of production use. Dimensions: 10.5 cm x 7.5 cm x 8.5 cm (4" x 3" x 3 1/4")

Estimate. £600 - 800

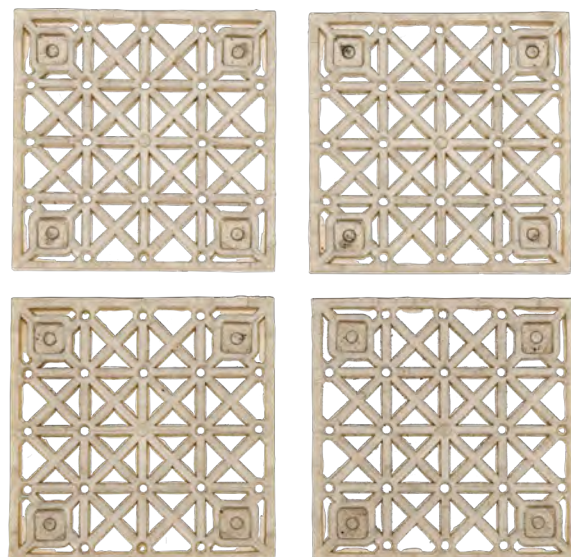

662
Four Miniature Floor Tiles M
Aliens (1986)

Four miniature floor tiles from James Cameron's sci-fi sequel Aliens. This style of floor tile was used on the models of the USS Sulaco hangar bay and the elevator that Ripley (Sigourney Weaver) took down to save Newt (Carrie Henn). The tiles are made of silver resin and feature a crosshatch design. Dimensions (each): 3.5 cm x 3.5 cm (1 1/2" x 1 1/2")

Estimate. £400 - 600



663
Pulse Rifle Design tΔ
Aliens (1986)

A printed pulse rifle design from the production of James Cameron's sci-fi action sequel Aliens. The page features a design for the iconic pulse rifle alongside features printed annotations. The design has been folded for storage, and the page has tears, wear to the edges and staining. Dimensions: 29.5 cm x 42 cm (11 1/2" x 16 1/2")

Estimate. £400 - 600

664
Autographed One-of-a-Kind
Replica Hero Pulse Rifle M
Aliens (1986)

An autographed, one-of-a-kind replica hero pulse rifle from James Cameron's sci-fi action sequel Aliens. Colonial Marines used their M41-A pulse rifles while battling xenomorphs on the planet LV-426. This custom built replica was created by professional effects artist Karl Derrick using a real M1A1 Thompson sub-machine gun and a Remington 870 pump-action shotgun, just as the hero version was on the production. Both weapons have been sympathetically deactivated. Bapty & Co, the armourers who supplied weapons for the film, gave Derrick access to the two remaining working pulse rifles so he could use them as reference. It is autographed on the magazine by actor Michael Biehn (Corporal Hicks), and accompanied by a letter of authenticity from Derrick, deactivation certificates for both weapons, and a carrying case. It has been intentionally distressed to appear well used, like the pulse rifles in Aliens. Dimensions: 71 cm x 7 cm x 26 cm (28" x 2 3/4" x 10 1/4") Firearm deactivated; see firearm deactivation notice in the Buyer's Guide. Restricted ownership; see replica firearm notice in the Buyer's Guide.

Estimate. £3,000 - 5,000



665
Terry English-made Replica Hicks
(Michael Biehn) Chestplate and Helmet M
Aliens (1986)

A Terry English-made replica Hicks (Michael Biehn) chestplate and helmet from James Cameron's sci-fi action sequel Aliens. Legendary armourer English designed and made the original armour for the Colonial Marines on the production and he has signed the inside of the chestplate in black marker pen. Both pieces are made of metal, decorated with a green camouflage pattern, and have "Hicks" printed in black on them. The chestplate also features Hicks' iconic painted heart and padlock. The helmet features a faux microphone and earpiece on one side, and a drop-down targeting sight above the right eye. The pieces have been intentionally distressed to appear well-worn and battle-scarred. Dimensions (chestplate): 45 cm x 40 cm x 16.5 cm (17 3/4" x 15 3/4" x 6 1/2");

Estimate. £1,500 - 2,500



667
Bound Final Script Ω
Aliens (1986)

A bound final script from the production of James Cameron's sci-fi action sequel Aliens. This 105-page script, also written by Cameron, is bound with brass brads and features a green cover labelled "Property of 20th Century Fox." Page 1 is dated "September 23, 1985." The script exhibits smudging and stains throughout the pages from handling with its cover torn loose and applied with tape by production. Dimensions: 23 cm x 28 cm x 5 cm (9" x 11" x 2")

Estimate. £800 - 1,200

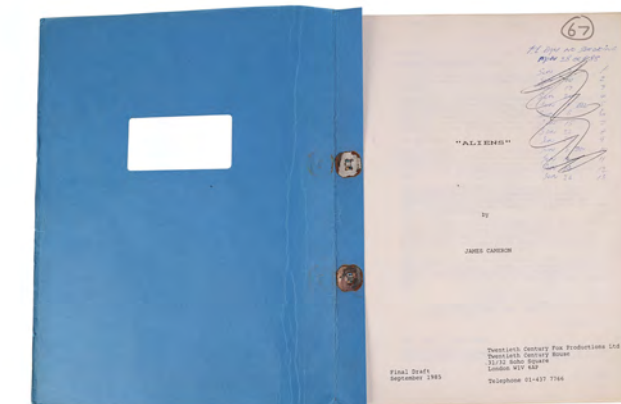

666
Harry Harris Collection:
Roy Charman's Production-Used Script M
Aliens (1986)

Roy Charman's production-used script from James Cameron's sci-fi sequel Aliens. Sound recordist Charman won an Academy Award® for his work on Raiders of the Lost Ark and was nominated three more times, including for Aliens. The script is 106 pages long and features handwritten annotations and crudely drawn sketches by Charman. The lot is accompanied by a list of Charman's credits, a printed picture of Charman, and a letter from Charman's wife Patricia. Dimensions: 28 cm x 22 cm x 1.5 cm (11" x 8 3/4" x 1/2")

Estimate. £800 - 1,200

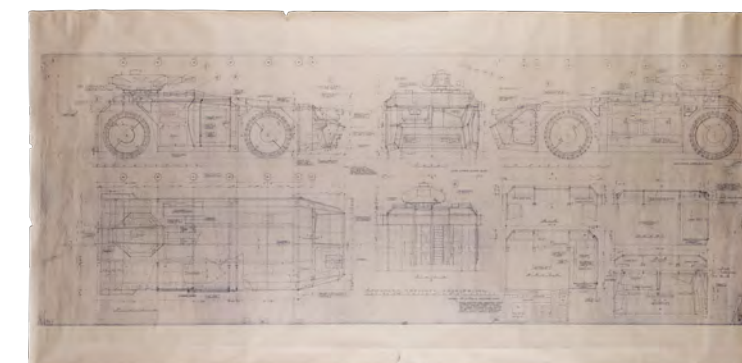

668
APC Exterior Blueprint M
Aliens (1986)

An APC exterior blueprint from the production of James Cameron's sci-fi sequel Aliens. Ripley (Sigourney Weaver), Hicks (Michael Biehn) and the other Marines arrived at terraforming colony Hadley's Hope in two Armoured Personnel Carriers (APCs). The large blueprint features the exterior plans for an APC. The print features several angles of the vehicle and includes dimensions and building materials. It is dated "20/8/85". The print has been rolled for storage and has some wear to the edges and some small holes. Dimensions: 100.5 cm x 209 cm (39 1/2" x 82 1/4")

Estimate. £600 - 800

669
Set of Three Hand-
Illustrated Dropship
Storyboards Ω
Aliens (1986)

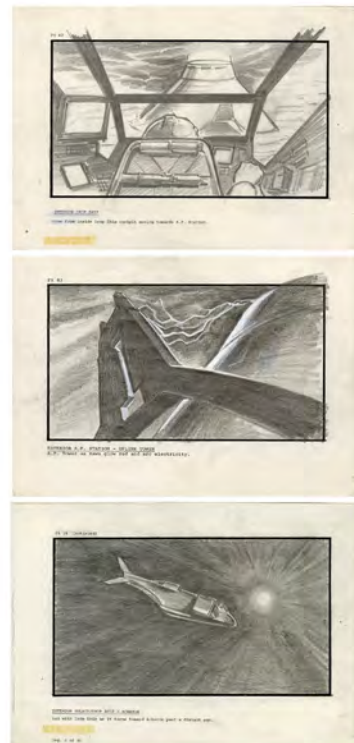

Three hand-illustrated dropship storyboards from the production of James Cameron's sci-fi action sequel Aliens. The UD-4L dropship known as Bug Stomper crash-landed on LV-426 when a xenomorph stowaway slaughtered the Colonial Marines onboard. This set consists of three unsigned, printed storyboards. Two feature the dropship and one features the A.P. Tower. Each has hand-rendered graphite illustrations. They are numbered "FX 42," "38 (Continued)," and "83," and printed with shot descriptions beneath the illustrations. The set exhibits tape residue and some staining in the margins. Dimensions (each): 30.5 cm x 30.5 cm (12" x 12") Sold without copyright; see notice in Buyer's Guide.

Estimate. £2,000 - 3,000

671
"Bug Stomper"
Crew Jacket
and Sweatshirt †Δ
Aliens (1986)



A "Bug Stomper" crew jacket and sweatshirt from the production of James Cameron's sci-fi action sequel Aliens. The grey cotton Reebok® jacket features a zip front closure, with knitted cuffs and waistband. The Aliens title is printed in blue on the left hip pocket and the distinctive Bug Stomper artwork - seen on the nose of the Colonial Marines' dropship in the film - adorns the back. Printed in different colours, the Bug Stomper artwork decorates the front of the white cotton polyester sweatshirt, and "Aliens" is printed on the left sleeve. Marked as size Large, both garments exhibit some minor staining.

Estimate. £500 - 700



670
Harry Harris
Collection: Hand-
Drawn Storyboard -
Dropship Lands M
Aliens (1986)

A hand-drawn storyboard from James Cameron's sci-fi sequel Aliens. The pencil storyboard depicts the dropship as it lands at Hadley's Hope colony. Labelled "FX 49", it is rendered onto A4 paper and features a short printed description of the shot underneath the illustration. "UL" is handwritten in the top right corner of the drawing and there are some lines of white correction fluid on the page. Dimensions: 21 cm x 30 cm (8 1/4" x 11 3/4") Sold without copyright; see copyright notice in the Buyer's Guide.

Estimate. £200 - 300

672
Fiorina 161
Inmate Costume M
Alien 3 (1992)



A Fiorina 161 inmate costume from David Fincher's sci-fi horror sequel Alien 3. Inmates wore their costumes throughout the film, and donned their overcoats while investigating the remnants of Ripley's (Sigourney Weaver) crashed ship. The costume consists of a heavy-duty cotton coat, a canvas overcoat (labelled "2 Craig Jones" inside the collar), a cotton T-shirt, a pair of cotton trousers, and a waterproof canvas hood. The costume has been intentionally distressed to appear well-worn and retains a slightly musty odour.

Estimate. £400 - 600



673
Harry Harris
Collection: Pair of
Alien Saga Jackets M
Alien 3 (1992)

A pair of jackets from the promotion of David Fincher's sci-fi horror sequel Alien 3. The lot includes a brown leather jacket with an "Alien 3" patch on the chest and references to the preceding Alien movies in the form of "Weyland-Yutani", "USCSS Nostromo" and "USCM" patches on the chest and arms, and an olive-coloured, quilted cotton drill bomber jacket with similar patches. The leather jacket is size "L" and the bomber jacket is size "XL".

Estimate. £200 - 300



675
Martin Asbury
Hand-drawn Pencil
Storyboard - Ripley
Meets the Alien M
Alien 3 (1992)

A Martin Asbury hand-drawn storyboard from David Fincher's sci-fi horror sequel Alien 3. The storyboard features four illustrations, predominantly rendered in pencil onto paper. They depict a scene in which Ripley (Sigourney Weaver) and the xenomorph come face-to-face, although the scene is different in the final cut. The page is titled "Library" and the illustrations have handwritten annotations next to them. Dimensions: 29.5 cm x 21 cm (11 1/2" x 8 1/4") Sold without copyright; see copyright notice in the Buyer's Guide.

Estimate. £800 - 1,200



674
Martin Asbury Hand-
drawn Pencil and Ink
Storyboards for the
Air Duct Killing M
Alien 3 (1992)

A collection of Martin Asbury hand-drawn storyboards from David Fincher's sci-fi horror sequel Alien 3. The collection includes four pages of illustrations in pencil and ink with accompanying handwritten annotations. They depict the scene in which one of the prisoners meets a grisly end in the air ducts. The pages are held together with a paper clip and they have some minor smudging in places. Dimensions: 29.5 cm x 21 cm (11 1/2" x 8 1/4") Sold without copyright; see copyright notice in the Buyer's Guide.

Estimate. £1,000 - 1,500

676
Xenomorph "Meat
Locker" Set Dec
Components ΩΔ
Alien 3 (1992)



Xenomorph "meat locker" set dec components from David Fincher's sci-fi horror sequel Alien 3. In a deleted scene, Ellen Ripley (Sigourney Weaver) discovered a "meat locker" - a new hive for the alien Queen - in Fiorina 161's Assembly Hall. These two brown and beige latex and foam rubber components were created as set decoration for the hive sequence by Academy Award®-winning special effects group Amalgamated Dynamics, Inc. (ADI). Both are textured with tube-shaped details and flat bottoms for mounting to the hive set. They exhibit cracking, discolouration, and scuffing throughout from production use and age. Dimensions (each): 52 cm x 52 cm x 53.5 cm (20.5" x 20.5" x 21")

Estimate. £800 - 1,200



677
Mad Sweeney's (Pablo Schreiber) Lucky Coin Ω
American Gods (T.V. Series, 2017 - 2021)

Mad Sweeney's (Pablo Schreiber) lucky coin from the fantasy drama series American Gods. Sweeney derived his leprechaun luck and extreme strength from his lucky coin, known as "the sun itself," throughout Seasons 1 and 2. This metallic coin is hand-painted to resemble gold. One side is engraved with a sun emblem, and the other is engraved with star and crescent moon emblems. The coin exhibits intentional distressing by production with flaking paint and nicks along the edges. Dimensions: 2.5 cm x 2.5 cm x 0.5 cm (1" x 1" x 0.25")

Estimate. £1,000 - 1,500



678
Production-used Clapperboard \mathcal{M}
Annie (1982)

A clapperboard from the production of John Huston's musical Annie. It features a chalkboard slate, a wooden clapper and a metal hinge. There are several strips of white masking tape adhered to its slate, upon which are written the film's title; the word "Test"; director Huston's name; cameraman Bri Murphy's name (uncredited); and the date "1.10.81". The clapper arm shows signs of wear. Dimensions: 28 cm x 23 cm x 2.5 cm (11" x 9" x 1")

Estimate. £1,000 - 1,500



679
"Argo" Movie Poster $\Omega\Delta$
Argo (2012)

An "Argo" movie poster from Ben Affleck's Academy Award®-winning thriller Argo. The CIA created posters for their fake sci-fi film, "Argo," as part of agent Tony Mendez's (Affleck) plan to rescue six American hostages from Iran. This colour poster depicting a futuristic space warrior surrounded by robots, aliens, and an otherworldly palace is printed on semi-gloss paper mounted to white backing. It exhibits visible wear along the edges, exposing the backing beneath. Dimensions: 47 cm x 31.75 cm (18.5" x 12.5")

Estimate. £1,000 - 1,500



680
Sheila's (Embeth Davidtz) Distressed Dress Ω
Army Of Darkness (1992)

Sheila's (Embeth Davidtz) distressed dress from Sam Raimi's horror action comedy Army of Darkness. Sheila's dress became increasingly torn and aged as she was turned into a deadite by Evil Ash (Bruce Campbell), then turned back into a human. This sheer pink, cotton blend ankle-length dress with a plunging neckline, wide frilled collar, and flowing sleeves which drape the full length of the dress also features leather laces on the reverse. The dress is extensively distressed by production, with the collar tattered and tears made throughout the neckline, sleeves, and hem.

Estimate. £2,000 - 3,000



681
Ash's (Bruce Campbell) Screen-matched Costume \mathcal{M}
Ash Vs Evil Dead (T.V. Series, 2015-2018)

Ash's (Bruce Campbell) screen-matched costume from the comedy/fantasy spin-off series Ash vs Evil Dead. This costume was worn in season two, episode 10 "Second Coming", in which Ash and his friends returned to the cabin where it all began to battle the past. His iconic blood-covered blue shirt screen-matches a scene later in the episode as he and Kelly (Dana DeLorenzo) watch the cabin explode into hellfire. The costume comprises: a screen-matched blue denim shirt with the hand-written label "Bruce Stunt", a production tag with scene references, plastic buttons and a hidden zip for ease of dressing; a cotton purple T-shirt with production distress; a pair of brown denim trousers with a hand-written label reading "Ash 36 slim leg #3 Preston"; a pair of brown leather boots with a hand-written label reading "Ash B/DBL #3 11 Preston" and a brown leather belt with a metal buckle.

Estimate. £3,000 - 5,000



682
Virtucon Binder [Ω](#)
Austin Powers: International Man Of Mystery (1997)

A Virtucon binder from Jay Roach's spy comedy Austin Powers: International Man of Mystery. Austin (Mike Myers) secretly photographed the contents of a binder at Alotta Fagina's (Fabiana Udenio) penthouse. It revealed Dr. Evil's (Myers) plan to drill a nuclear warhead into the Earth's core. The binder has the logo of Virtucon, Dr. Evil's company, on its front cover, and contains 14 pages. Dimensions: 29.5 cm x 25 cm x 2 cm (11 3/4" x 9 3/4" x 3/4")

Estimate. £600 - 800



683
"Swinger" Car Licence Plate and "Shaguar" Badges [Ω](#)
Austin Powers: The Spy Who Shagged Me (1999)

A "Swinger" car licence plate and three "Shaguar" badges from Jay's Roach's spy comedy sequel Austin Powers: The Spy Who Shagged Me. Austin drove his Union Jack-decorated "Shaguar" car with the licence plate "Swinger". The licence plate is made of black metal with raised white lettering, and the three badges are made of chrome-plated plastic. Dimensions (licence plate): 12.5 cm x 51 cm (5" x 20")

Estimate. £2,000 - 3,000



684
"Swinger 2" Licence Plate [M](#)
Austin Powers: The Spy Who Shagged Me (1999)

A "Swinger 2" licence plate from Jay Roach's spy comedy Austin Powers: The Spy Who Shagged Me. Austin Powers (Mike Myers) used his time-travelling Volkswagen New Beetle to return to 1969 and track down Dr. Evil (Myers). The iconic licence plate can be seen on the front and rear of the vehicle. Made of aluminium, the plate features white raised text reading "Swingers 2" over a black background. The reverse side exhibits rusting from age, while the front displays minor chips to the black coating from production use. Dimensions: 51 cm x 13 cm (20" x 5 1/4")

Estimate. £2,000 - 3,000



685
Felicity Shagwell's (Heather Graham) Necklace [M](#)
Austin Powers: The Spy Who Shagged Me (1999)

Felicity Shagwell's (Heather Graham) necklace from Jay Roach's 1999 spy spoof sequel Austin Powers: The Spy Who Shagged Me. CIA agent Shagwell wore her necklace when she and Austin Powers (Mike Myers) infiltrated Dr. Evil's (Mike Myers) Caribbean island. She wore different versions of the necklace throughout the film. The metal necklace is collar-shaped, with a Venus-symbol pendant, representing femininity. It exhibits some signs of tarnishing to the metal and the collar is slightly misshapen. Dimensions: 15.5 cm x 12.5 cm x 0.1 cm (6 1/4" x 5" x 1/4")

Estimate. £2,000 - 3,000



686
Dr. Evil Watch and Notepad, Crew Window Cards and Mini Me (Verne Troyer) Briefcase [Ω](#)
Austin Powers: The Spy Who Shagged Me (1999)

A set of items from Jay Roach's comedy sequel Austin Powers: The Spy Who Shagged Me. Dr. Evil themed watches and notepads were used by the employees and henchmen of Dr. Evil (Mike Myers), Mini-Me (Verne Troyer) held his briefcase as he entered the questionably shaped spaceship, and window cards were used by the production's crew. The watch is a Timex stainless steel watchface with the Dr. Evil logo in the centre and leather straps; the notepads consist of a set of six pads, four of which feature the logo and two have the phrase "From the desk of Dr. Evil" printed in black ink on each page; the window plaques are laminated paper featuring the film title, one also features a label reading the prop master's name and title; Mini-Me's briefcase is aluminium with a plastic handle, it is filled with foam to hold a single tape labelled "Master Mix". Dimensions: (Briefcase) 30 cm x 27 cm x 11 cm (11 3/4" x 10 1/2" x 4 1/4")

Estimate. £1,500 - 2,500



688
Screen-matched "Dr. Evil's Private Volcano Island" Sign [Ω](#)
Austin Powers: The Spy Who Shagged Me (1999)

A screen-matched "Dr. Evil's Private Volcano Island" sign from Jay's Roach's spy comedy sequel Austin Powers: The Spy Who Shagged Me. The sign greeted Austin (Mike Myers) and Felicity Shagwell (Heather Graham) when they arrived on the island's beach. It matches the one seen on screen through its markings and intentional weathering. The sign is made of white-painted wood, with a sheet of plastic stapled to its top that reads, "Keep Out". The sign is intentionally distressed and has an unpainted section on the back where it was previously attached to a post. Dimensions: 61 cm x 76 cm (24" x 30")

Estimate. £1,000 - 1,500

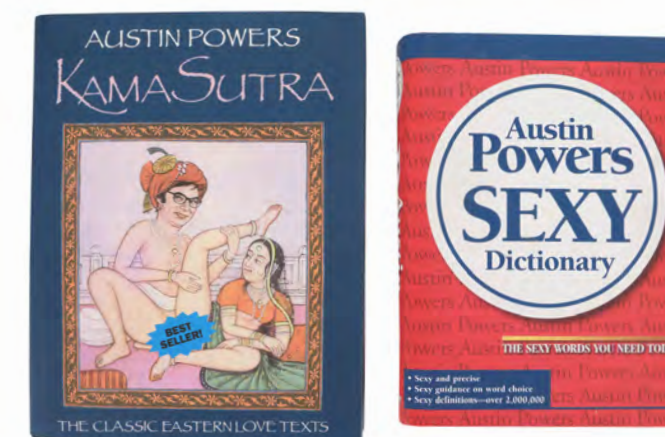

687
Austin Powers' (Mike Myers) Kama Sutra and Sexy Dictionary [Ω](#)
Austin Powers: The Spy Who Shagged Me (1999)

Austin Powers' (Mike Myers) Kama Sutra and Sexy Dictionary from Jay Roach's spy comedy sequel Austin Powers: The Spy Who Shagged Me. Austin held his copy of the Kama Sutra in bed with Vanessa Kensington (Elizabeth Hurley) at the beginning of the film. The Sexy Dictionary is not seen on screen. The Kama Sutra features a cover illustration of a naked Austin with his private parts covered, and is wrapped around a copy of The History of Freemasonry by Dr. Albert Mackey and William Hughan. The Sexy Dictionary cover is wrapped around an actual dictionary. The covers have some minor scuffing. Dimensions (Kama Sutra): 28.5 cm x 22.5 cm x 4 cm (11 1/2" x 8 3/4" x 1 1/2")

Estimate. £1,500 - 2,500

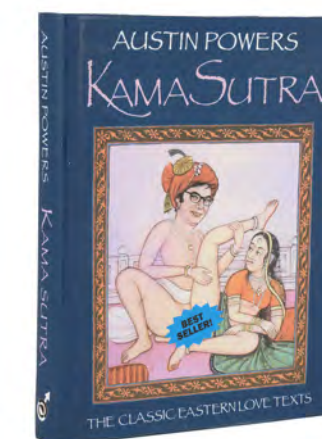

689
Austin Powers' (Mike Myers) Kama Sutra Book [Ω](#)
Austin Powers: The Spy Who Shagged Me (1999)

Austin Powers' (Mike Myers) Kama Sutra book from Jay Roach's spy comedy sequel Austin Powers: The Spy Who Shagged Me. Austin held up his Kama Sutra book whilst enjoying his honeymoon with his new wife Vanessa (Elizabeth Hurley). The custom-made navy-coloured cover shows Powers' face wearing a turban superimposed onto a male figure intertwined with a female figure. A summary of the book and several reviews are printed on the back cover in white. The sleeve covers a copy of Albert Gallatin Mackey's "The History of Freemasonry; Its Legendary Origins". Some minor marks and edge wear are present on the back cover. Dimensions: 28.5 cm x 22.5 cm x 4 cm (11 1/4" x 8 3/4" x 1 1/2")

Estimate. £1,000 - 1,500

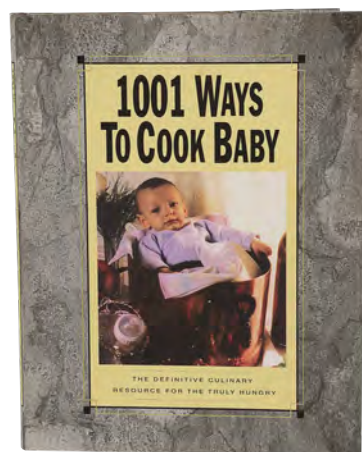

690
Fat Bastard's (Mike Myers) Baby Cookbook [Ω](#)
Austin Powers: The Spy Who Shagged Me (1999)

Fat Bastard's (Mike Myers) baby cookbook from Jay Roach's spy comedy sequel Austin Powers: The Spy Who Shagged Me. Fat Bastard read his "1001 Ways To Cook Baby" book within Dr. Evil's (Mike Myers) secret volcanic lair in a deleted scene. The cover features a picture of a baby in a cooking pot with the tagline "The Definitive Culinary Resource For The Truly Hungry" printed underneath. A summary of the book and several reviews are printed on the back. The sleeve covers a copy of Frank McLynn's "Famous Letters: Messages and Thoughts That Shaped Our World", and the book comes with three additional printed copies of the cover image. Dimensions: 29 cm x 22.5 cm x 2 cm (11 1/4" x 8 3/4" x 3/4")

Estimate. £400 - 600

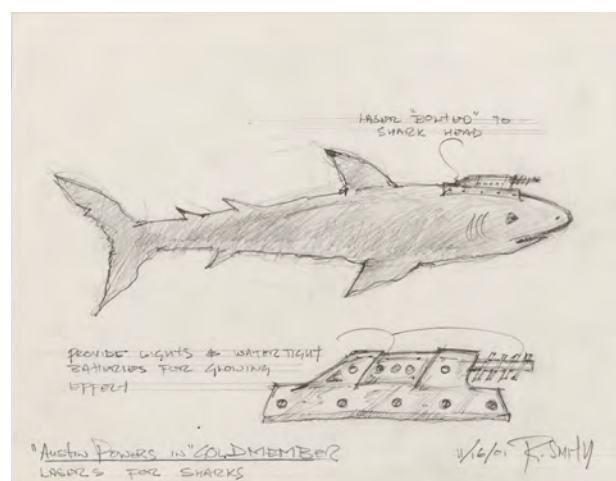

692
Hand-drawn Shark with Laser beams Concept Illustration [Ω](#)
Austin Powers In Goldmember (2002)

A hand-drawn shark with laser beams concept illustration from the production of Jay Roach's spy-comedy sequel Austin Powers in Goldmember. Created by production designer Rusty Smith, the pencil drawing shows a shark with a laser beam contraption "bolted" to its head, with a more detailed design of the laser beam below. The artwork is dated "11/16/01", signed by Smith and features annotations. It is mounted in a black wooden frame that features a hanging wire attached to the back. The illustration exhibits some smudges on the paper from production use. Dimensions: 35 cm x 43 cm x 1.5 cm (13 3/4" x 17" x 3/4") Sold without copyright; see copyright notice in the Buyer's Guide.

Estimate. £400 - 600



691
Fat Bastard's (Mike Myers) Knife and Sheath [Ω](#)
Austin Powers: The Spy Who Shagged Me (1999)

Fat Bastard's (Mike Myers) knife and sheath from Jay Roach's spy comedy sequel Austin Powers: The Spy Who Shagged Me. The large Scotsman wore a knife as part of his uniform when he posed as a guard in the British Ministry of Defense and stole Austin Powers' (Mike Myers) mojo from his cryogenic chamber. The knife comprises a metal blade decorated with ornate leaf-inspired patterns, and a resin grip finished to replicate studded black leather. The black leather sheath features silver metal hardware and a belt loop. Dimensions (knife): 43.5 cm x 4 cm x 4.5 cm (17" x 1 1/2" x 1 3/4")

Estimate. £600 - 800



693
Goldmember Key Prototype, Evil Medical School Envelopes [Ω](#)
Austin Powers In Goldmember (2002)

A prototype Goldmember key and Evil Medical School envelopes from Jay Roach's comedy sequel Austin Powers: Goldmember. The phallic key was presented to Goldmember (Mike Myers) by Mr. Roboto and was needed to activate the Tractor Beam - prototypes such as this were made by the production to test the final look and materials. The key is machine cut aluminium in the shape of a male appendage, it is unpainted yet features many details similar to the final version used during filming. Though ultimately unseen on screen, the envelopes were made by the production and are addressed to a Master Evil; the set consists of 30 paper envelopes featuring the symbol of Caduceus and "Evil Medical School". Dimensions: (Key) 26 cm x 12 cm x 4 cm (10 1/4" x 4 3/4" x 1 1/2"), (Envelope) 24.5 cm x 10.5 (9 1/2" x 4")

Estimate. £600 - 800



694
Set of Scripts, Crew Gifts and Chair Backs [Ω](#)
Austin Powers: The Spy Who Shagged Me (1999) And Austin Powers In Goldmember (2002)

A collection of scripts, crew gifts and chairbacks from the production of Jay Roach's spy comedy sequels Austin Powers: The Spy Who Shagged Me and Austin Powers in Goldmember. The two scripts consist of an "Austin Powers 2: The Wrath of Khan" first production draft dated "8/10/98" and a purple Goldmember second draft dated "October 4, 2001". The lot also includes a Goldmember polyester sports jersey (marked size XL); a Goldmember white T-shirt (marked size XL); a Goldmember "G" pendant; a Goldmember rollerskate keyring; two The Spy Who Shagged Me cocktail shakers; a Goldmember premiere invitation; a The Spy Who Shagged Me inventory photo binder; two The Spy Who Shagged Me yellow chairbacks; and a black "Mike Myers" chairback from Goldmember. One yellow chairback exhibits several marks. Dimensions (each script): 28 cm x 22 cm x 2 cm (11" x 8 1/2" x 3/4"); (each chairback): 17.5 cm x 55 cm x 0.5 cm (6 3/4" x 21 1/2" x 1/4")

Estimate. £600 - 800



695
John Steed's (Patrick Macnee) Black Bowler Hat [M](#)
Avengers, The (T.V. Series, 1961 - 1969)

John Steed's (Patrick Macnee) black bowler hat from the British spy-fi television series The Avengers. The bowler hat was part of Steed's trademark costume and served as one of his favourite weapons. He wore different coloured versions throughout the show and donned a black hat during multiple episodes. This hat was gifted by Macnee, at an end-of-shoot party, to a crew member who worked on the seasons which featured Emma Peel (Diana Rigg). Created by Dunn & Co., the bowler hat is made of black felt and features a black ribbon. The interior displays a leather sweatband and a Dunn & Co. label. The ribbon has become discoloured over time, and there are signs of damage on the sweatband. The lot includes a letter of authenticity from the crew member to whom it was gifted.

Estimate. £3,000 - 5,000





696
Surveillance Wasp +
Avengers, The (1998)

A surveillance wasp from Jeremiah S. Chachik's film adaptation of the iconic television series The Avengers. Drone-like wasps were created by Sir August de Wynter (Sean Connery) and controlled by Bailey (Eddie Izzard) to hunt down John Steed (Ralph Fiennes) and Dr. Emma Peel (Uma Thurman) in their blue 1970 E-Type Jaguar. The wasp is made from vac-formed plastic with aluminium legs, rubber toothed belts and steel inner components. It has resin wings and helicopter blades, and has an orange-coloured plastic stinger used as a placeholder for special effects purposes. The wasp is vacuum metalised silver, has poseable legs, feet and a segmented abdomen allowing movement. It shows minor damage to the plastic from time spent in storage and can be taken apart into three separate pieces. Dimensions (assembled): 120 cm x 80 cm x 55 cm (47" x 31 1/2" x 21 1/2")

Estimate. £3,000 - 5,000



698
Torn Phone-book Directory Page +
Back To The Future (1985)

A torn phone-book directory page from Robert Zemeckis' sci-fi comedy adventure Back to the Future. Marty McFly (Michael J. Fox) ripped a page from a telephone book in Lou's Cafe while trying to track down scientist Dr. Emmett Brown (Christopher Lloyd) in 1955. The double-sided page is numbered 33 to 34, with an intentional tear running down one side. The page features contact information for Brown, which reads "Brown Emmet L. scientist - 1640 Riverside dr." The page remains in an unfolded state, has become discoloured over time and displays minor wear. Dimensions: 28 cm x 21.5 cm (11" x 8 1/2")

Estimate. £2,000 - 3,000



697
Michael J. Fox-Autographed Gibson ES-345 Guitar +
Back To The Future (1985)

A Gibson ES-345 guitar autographed by Michael J. Fox, star of Robert Zemeckis' sci-fi adventure film Back to the Future. This guitar is a 2015 reissue of a 1960s Gibson ES-345 cherry red guitar, very similar to the 1958 model that Marty McFly (Fox) played during the "Enchantment Under the Sea" dance in the film. This guitar is signed in silver-colour ink by Michael J. Fox along with his character name, "Marty McFly." It comes in a black leather hard case with a yellow plush interior and includes a Certificate of Authenticity from Gibson Memphis. The guitar and case exhibit minimal signs of handling. Dimensions: 106.75 cm x 40.75 cm x 7.75 cm (42" x 16" x 3") Contains electronics; see electronics notice in the Buyer's Guide.

Estimate. £3,000 - 5,000



699
Michael J. Fox, Christopher
Lloyd and Drew Struzan Autographed Poster +
Back To The Future (1985)

An autographed poster from the promotion of Robert Zemeckis' sci-fi comedy adventure Back to the Future. This commercial one-sheet features artwork by renowned poster artist Drew Struzan and shows Marty McFly (Michael J. Fox) standing checking his watch next to the infamous DeLorean time machine with lines of flames along the floor. It has been autographed in blue ink by Fox, Christopher Lloyd (Doc Brown) and artist Drew Struzan. There are signs of creasing present near the bottom right corner. Dimensions: 101.5 cm x 68.5 cm (40" x 27")

Estimate. £800 - 1,200



700
Universal Studios Press Kit +
Back To The Future (1985)

A press kit created by Universal Studios to promote Robert Zemeckis' sci-fi adventure Back to the Future. The kit consists of 14 black-and-white stills from the production printed on glossy Amblin photo stock; seven stapled synopsis and character packets for Marty McFly (Michael J. Fox), Doc Brown (Christopher Lloyd), and George McFly (Crispin Glover) printed on "Universal News" letterhead; and a press information folder labelled "Back to the Future" and "From Universal An MCA Company." The staples are rusted and the folder exhibits tears and stains throughout from age and handling. Dimensions (each): 30.5 cm x 25.5 cm (12" x 10")

Estimate. £300 - 500



702
Spike's (Darlene Vogel)
Screen-matched 1980s Leotard +
Back To The Future Part II (1989)

Spike's (Darlene Vogel) screen-matched 1980s leotard from Robert Zemeckis' sci-fi sequel Back to the Future Part II. Spike wore her leotard in the 1980s-themed diner, where she and Griff's (Thomas F. Wilson) gang attempted to bully Marty McFly Jr. (Michael J. Fox) into taking part in a robbery. The placement of the leotard's triangular pattern screen-matches it to the moment Spike grabbed Marty Jr.'s groin, and when the gang hooked onto Griff's "P.I.T Bull" rocket-powered hoverboard. The white high-necked leotard features a black geometric pattern with bra cups sewn into the interior. Two decorative lightweight nylon braided tubes finished in copper-coloured paint are adhered around the sleeves. A Bill Hargate costumier label with the text "Darlene #2" is sewn inside the collar. The lot exhibits some staining and marks, and one of the tubes is loose at the neck.

Estimate. £2,000 - 3,000



701
CusCo "You're Fired!!!" Fax +
Back To The Future Part II (1989)

A CusCo "You're Fired!!!" fax from Robert Zemeckis' sci-fi adventure sequel Back to the Future Part II. After agreeing to an illegal deal with co-worker Needles (Flea), McFly was caught and fired over the phone by Mr. Fujitsu (Jim Ishida), causing faxes to appear throughout the house. Though this style is not obviously seen on screen, this sheet of light grey paper features a large "YOU'RE FIRED!!!" in a bold font, along with a burgundy "CUSCO" graphic and the address of the company at the top of the page. This fax has been adhered to a piece of thick card for display purposes. Dimensions (fax): 28 cm x 24.5 cm (11" x 9 1/2")

Estimate. £2,000 - 3,000



703
McFly Family Dehydrated Pizza Hut Wrapper +
Back To The Future Part II (1989)

A dehydrated Pizza Hut wrapper from Robert Zemeckis' sci-fi adventure sequel Back to the Future Part II. In the future of 2015, Lorraine McFly (Lea Thompson) brought a bag of rehydratable pizzas to a family dinner at her son Marty's (Michael J. Fox) house. This opened silver, red and black foil wrapper features a printed Pizza Hut logo and meal preparation instructions. The wrapper displays light creasing from production use, with some glue remnants on the front, while the red has faded over time. Dimensions: 14 cm x 13.5 cm (5 1/2" x 5 1/4")

Estimate. £1,500 - 2,500



704
Oh La La Cover M
Back To The Future Part II (1989)

An "Oh La La" magazine cover from Robert Zemeckis' sci-fi sequel Back to the Future II. Biff Tannen (Thomas F. Wilson) read his Oh La La magazine at the dance back in 1955. Later Marty McFly (Michael J. Fox) discovered that Biff had switched the cover to disguise the Sports Almanac. This double spread magazine cover comes unfolded with one side displaying the front and back cover. The front cover features the magazine's title whilst the back cover reads 'Le Mois Prochain Dans Oh La La'. The reverse spread is split between the contents page, which is written in french, and a black and white image of a lady in a polka dot bodysuit. Dimensions: 23 cm x 30.5 cm (9" x 12")

Estimate. £800 - 1,200



706
Hill Valley Telegraph Newspaper M
Back To The Future Part III (1990)

A Hill Valley Telegraph newspaper from Robert Zemeckis' sci-fi adventure sequel Back to the Future Part III. After travelling back to 1885, Marty McFly (Michael J. Fox) encountered Buford "Mad Dog" Tannen (Thomas F. Wilson) in a saloon where a man was reading the newspaper behind them. This Hill Valley Telegraph newspaper is dated "September 4th, 1885". It features 12 pages of black-and-white newsprint paper, with repeating content in the interior pages. There is slight discolouration on the pages. Dimensions: 40.5 cm x 30.5 cm (16" x 12")

Estimate. £1,000 - 1,500

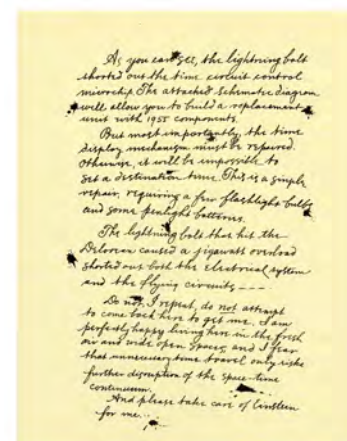

705
Page from Doc's (Christopher Lloyd)
1885 DeLorean Repair Letter to Marty (Michael J. Fox) Ω
Back To The Future Part III (1990)

A page from Doc's (Christopher Lloyd) 1885 DeLorean repair letter to Marty (Michael J. Fox) from Robert Zemeckis' sci-fi adventure sequel Back to the Future Part III. In 1955, McFly discovered a letter sent by 1885-era Doc Brown on how to fix the DeLorean, then read it to 1955-era Brown. This paper letter features cursive text printed in black ink. Although the text varies slightly from what is spoken and seen in the final cut, it contains several of the same phrases and elements McFly reads out loud. The letter exhibits several production-made ink blotches and minor discolouration from age. Dimensions: 28 cm x 21.5 cm (11" x 8.5")

Estimate. £1,200 - 1,800



707
Steven Spielberg Chair Back M
Band Of Brothers (T.V. Series, 2001)

A Steven Spielberg chair back from the production of war drama mini-series Band of Brothers, executive produced by Spielberg. This black canvas chair back features the series title on one side and Spielberg's name embroidered in gold thread on the reverse. The stitches holding the sides of the chair back together have been removed. Dimensions: 60 cm x 18 cm x 0.5 cm (23 3/4" x 7 1/2" x 1/2")

Estimate. £800 - 1,200



708
Cast-autographed Helmet,
Tom Hanks-autographed
Book and Crew Jacket M
Band Of Brothers (T.V. Series, 2001)

A cast-autographed Helmet, Tom Hanks-autographed book and crew jacket from the WWII miniseries Band of Brothers. The metal helmet has been signed by 19 members of the cast. Inside is labelled "J.J. Whitby", who had an uncredited role on the series. Stephen E. Ambrose's book Band of Brother, upon which the series was based, is autographed on the title page by Tom and Colin Hanks. The black crew jacket is labelled size "S". Dimensions (helmet): 28 cm x 23.5 cm x 17 cm (11" x 9 1/4" x 6 3/4")

Estimate. £600 - 800

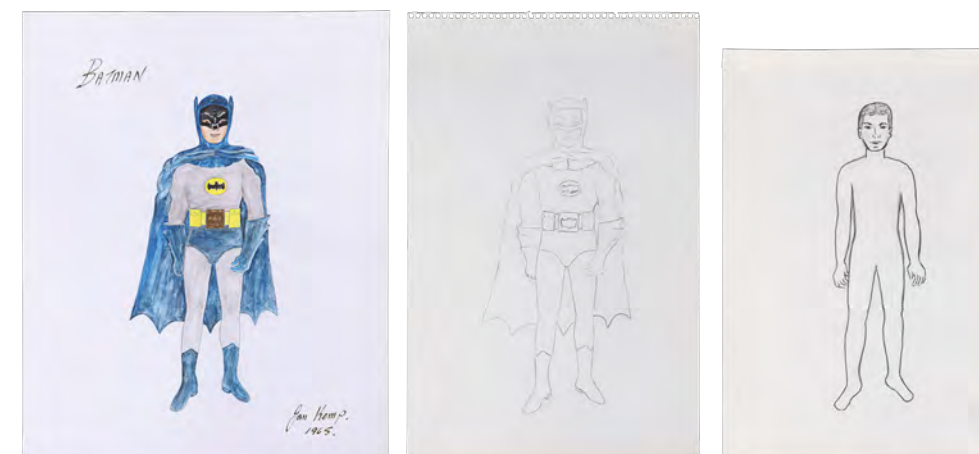

709
Jan Kemp Hand-drawn
and Painted Batman
(Adam West) Costume Designs M
Batman (T.V. Series, 1966 - 1968)

Jan Kemp hand-drawn and painted Batman (Adam West) costume designs from the production of superhero TV series Batman. Acquired from his family, these designs by principal costume designer Kemp feature Batman in his iconic grey-and-blue batsuit. One is rendered in pencil and watercolour on thick paper, and two are rendered in pencil. The character's name is handwritten above the watercolour design and Kemp has signed and dated it "1965" below. Dimensions (colour design): 43 cm x 35.5 cm (17" x 14") Sold without copyright; see copyright notice in the Buyer's Guide.

Estimate. £3,000 - 5,000



710
Jan Kemp Hand-drawn
and Painted Robin
(Burt Ward) Costume Designs M
Batman (T.V. Series, 1966 - 1968)

Jan Kemp hand-drawn and painted Robin (Burt Ward) costume designs from the production of superhero TV series Batman. Acquired from his family, these designs by principal costume designer Kemp feature "The Boy Wonder" in his iconic red, green and yellow costume. Both are rendered on thick paper, one in pencil and the other in pencil and watercolour. The character's name is handwritten above the watercolour design and Kemp has signed and dated it "1965" below. Dimensions (colour design): 43 cm x 35.5 cm (17" x 14") Sold without copyright; see copyright notice in the Buyer's Guide.

Estimate. £3,000 - 5,000



711
Jan Kemp Hand-drawn and Painted Joker (Cesar Romero) Costume Designs M
Batman (T.V. Series, 1966 - 1968)

Jan Kemp hand-drawn and painted Joker (Cesar Romero) costume designs from the production of superhero TV series Batman. Acquired from his family, these designs by principal costume designer Kemp feature the Joker in his classic purple suit with a green shirt. Both are rendered on thick paper, one in pencil and the other in pencil and watercolour. The character's name is handwritten above the watercolour design and Kemp has signed and dated it "1965" below. Dimensions (colour design): 43 cm x 35.5 cm (17" x 14") Sold without copyright; see copyright notice in the Buyer's Guide.

Estimate. £3,000 - 5,000



714
Jan Kemp Hand-drawn and Painted Egghead (Vincent Price) Costume Design M
Batman (T.V. Series, 1966 - 1968)

A Jan Kemp hand-drawn and painted Egghead (Vincent Price) costume design from the production of superhero TV series Batman. "The world's smartest criminal" Egghead originated on the television show, before moving to the comics. Acquired from the family of principal costume designer Kemp, the design features Egghead in a white suit with a yellow shirt. It is rendered in pencil and watercolour on thick paper. The character's name is handwritten at the top of the design and Kemp has signed and dated it "1965" below. Dimensions: 43 cm x 35.5 cm (17" x 14") Sold without copyright; see copyright notice in the Buyer's Guide.

Estimate. £1,000 - 1,500



715
Two Joker Supermarket Smylex Boxes M
Batman (1989)

Two Smylex boxes from Tim Burton's superhero film Batman. Colourful boxes branded with the Joker's face filled a shopping trolley and supermarket shelves in the villain's commercial for the deadly new product Smylex, broadcast during an Action News report show. One box is wrapped in neon-pink paper, with a bright green star shape featuring a cartoon image of the Joker adhered to the top. The other box is wrapped in bright orange paper, decorated with a green diagonal stripe and the same Joker emblem. There are several small marks on the pink paper. Dimensions (pink box): 15 cm x 23 cm x 15.5 cm (6" x 9" x 6 1/4"); (orange box): 19.5 cm x 26.5 cm x 7.5 cm (7 3/4" x 10 1/2" x 3")

Estimate. £1,000 - 1,500



712
Jan Kemp Hand-drawn and Painted Riddler (Frank Gorshin) Costume Designs M
Batman (T.V. Series, 1966 - 1968)

Jan Kemp hand-drawn and painted Riddler (Frank Gorshin) costume designs from the production of superhero TV series Batman. Acquired from his family, these designs by principal costume designer Kemp feature Riddler in his classic question mark costume. Both are rendered on thick paper, one in pencil and the other in watercolour and pencil. The character's name is handwritten above the watercolour design and Kemp has signed and dated it "1965" below. Dimensions (colour design): 43 cm x 35.5 cm (17" x 14") Sold without copyright; see copyright notice in the Buyer's Guide.

Estimate. £2,000 - 3,000



716
Cathedral Bell Tower Gargoyle M
Batman (1989)

A cathedral bell tower gargoyle from Tim Burton's superhero film Batman. Gargoyles adorned the cathedral's bell tower, seen in the climactic showdown between Napier/The Joker, Batman (Michael Keaton), and Vicki Vale (Kim Basinger). The menacing gargoyle is made of light grey-painted cast concrete and features a pair of piercing eyes, an open mouth and a long textured neck. It is missing its horns and displays signs of paint wear, notably around the mouth. Dimensions: 43 cm x 22 cm x 20 cm (17" x 8 3/4" x 8")

Estimate. £600 - 800



717
Derek Meddings Hand-drawn Pencil Concept Sketch for the Batwing M
Batman (1989)

A concept sketch hand-drawn by legendary visual effects artist Derek Meddings from the production of Tim Burton's superhero film Batman. Meddings supervised the construction of the Batwing, which was flown by Batman (Michael Keaton) as he took on the Joker (Jack Nicholson). The sketch comprises two pencil drawings of the Batwing, with "842117" handwritten in blue ink along one edge. Dimensions: 26.5 cm x 33 cm (10 1/2" x 13") Sold without copyright; see copyright notice in the Buyer's Guide.

Estimate. £800 - 1,200



713
Jan Kemp Hand-drawn and Painted Penguin (Burgess Meredith) Costume Designs M
Batman (T.V. Series, 1966 - 1968)

Jan Kemp hand-drawn and painted Penguin (Burgess Meredith) costume designs from the production of superhero TV series Batman. Acquired from his family, these designs by principal costume designer Kemp feature Penguin in his classic tuxedo costume. Both are rendered on thick paper, one in pencil and the other in watercolour and pencil. The character's name is handwritten above the watercolour design and Kemp has signed and dated it "1965" below. Dimensions (colour design): 43 cm x 35.5 cm (17" x 14") Sold without copyright; see copyright notice in the Buyer's Guide.

Estimate. £2,000 - 3,000



718
Collection of Hand-drawn Storyboards \pm
Batman (1989)

A collection of hand-drawn storyboards from the production of Tim Burton's superhero film Batman. This set depicts the sequence where Batman (Michael Keaton) used the Batmobile to break into the Axis Chemicals plant, before using an explosive device to destroy the facility. The lot comprises 11 sheets, with each image rendered in a combination of pencil and black pen. Each page is titled "Batman, Ace Chemicals Seq. Batboards" and the text "Pinewood '88" is located down the right side. Some of the storyboards display pencil smudging. Dimensions (each sheet): 29.5 cm x 21 cm (11 1/2" x 8 1/4") Sold without copyright; see copyright notice in the Buyer's Guide.

Estimate. £2,000 - 3,000



720
Set of 112 Printed Storyboards Ω
Batman (1989)

112 printed storyboards from the production of Tim Burton's superhero film Batman. Batman (Michael Keaton) battled master criminal The Joker (Jack Nicholson) in Gotham City. This set of 112 black-and-white storyboards was copied from hand-drawn storyboards by the production for distribution amongst key departments. The storyboards are labelled "Batman" and span the bulk of the film, with scene numbers, multiple annotations, the date "88," and the location "Pinewood" printed throughout. Some storyboards are numbered, while others' numbers are cut off from the printing. The set exhibits bending and edge wear throughout. Dimensions (each): 21.75 cm x 28 cm (8.5" x 11")

Estimate. £800 - 1,200

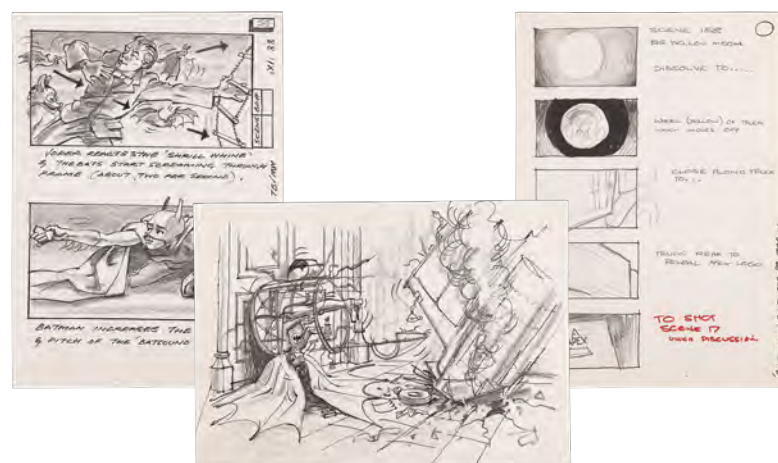

719
Set of Three Hand-drawn Storyboards \pm
Batman (1989)

A set of hand-drawn storyboards from the production of Tim Burton's superhero film Batman. The lot consists of three pages depicting various shots, including Batman (Michael Keaton) using his sonar device, causing bats to attack the Joker (Jack Nicholson). The majority of the storyboards are illustrated in pencil and black pen, with some printed elements. One page, labelled "59", features brief descriptions below each image, with the text "Batman, Pinewood, TB/MW, X1: 88" located down the right side. Tippex has been applied to the largest illustration. Dimensions (each sheet): 29.5 cm x 21 cm (11 1/2" x 8 1/4") Sold without copyright; see copyright notice in the Buyer's Guide.

Estimate. £1,000 - 1,500



721
Third Draft Script \mathcal{M}
Batman (1989)

A production-used script from the production of Tim Burton's superhero film Batman. Bound in black card with metal fastenings, the 112-page script is printed on white A4 paper and is dated "February 29th 1988". The card cover features a cut-out window revealing the film's title on the first page, and the issue number "35" is handwritten in the top right corner of the title page. Corrosion marks are present on the metal fastenings, and the cover exhibits white marks. Dimensions: 30 cm x 21.5 cm x 1.5 cm (11 3/4" x 8 1/2" x 1/2")

Estimate. £600 - 800



722
Crew Jacket, Stunts Hat and Screening Invitation \mathcal{M}
Batman (1989)

A crew jacket, hat and screening ticket from the post-production of Tim Burton's take on the caped crusader Batman. The jacket is a black leather bomber (size M) with a faux-fur collar and metal fasteners and zip, it features a Batman patch on the right shoulder and a Joker emblem on the left. The hat is red cotton with a plastic adjuster in the back, it features "Stunts Batman Feature Action LTD" printed on the front with an image of Batman. The screening ticket is card printed with the Batman emblem, inside features details relating to a private screening of the film. These items come from the personal collection of Carl Newman, Michael Keaton's movement double, and is accompanied by a letter from him. Dimensions: (ticket) 17.5 cm x 11 cm (7" x 4 1/4")

Estimate. £1,500 - 2,500

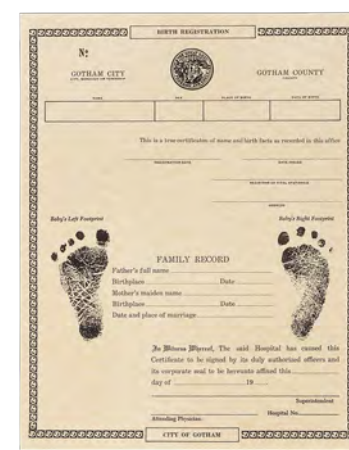

724
Gotham City Birth Certificate \mathcal{M}
Batman Returns (1992)

A Gotham City birth certificate from Tim Burton's superhero sequel Batman Returns. The Penguin (Danny DeVito) looked at birth certificates at the Gotham Hall of Records and made a list of firstborn sons of wealthy families, targeting them for murder. This blank certificate is printed on paper and features sections where information can be entered, as well as two printed baby footprints. Dimensions: 27.5 cm x 21.5 cm (10 3/4" x 8 1/2")

Estimate. £400 - 600



723
Catwoman's (Michelle Pfeiffer) Costume Stitches Ω
Batman Returns (1992)

Catwoman's (Michelle Pfeiffer) costume stitches from Tim Burton's superhero sequel Batman Returns. After Max Shreck (Christopher Walken) attempted to murder her, the reborn Selina Kyle sought vengeance as Catwoman. This set of 21 black latex costume components features Catwoman's signature white stitching running throughout, as designed by costume designers Bob Ringwood and Mary Vogt. Each is presented loose, having fallen away from the full bodysuit after production. While they have since undergone minor restoration efforts to stabilize and preserve their distinctive gloss, the stitches remain fragile from production use and age with flaking and peeling throughout.

Estimate. £1,000 - 1,500



725
Michael Keaton, Michelle Pfeiffer and Danny DeVito's Lifecasts \mathcal{M}
Batman Returns (1992)

Michael Keaton, Michelle Pfeiffer and Danny DeVito's lifecasts from the production of Tim Burton's superhero sequel Batman Returns. Lifecasts of the actor's heads were made during the early stages of pre-production to model the film's masks and costumes, including the iconic Batman cowl, designed by costume designer Bob Ringwood and created by Vin Burnham and co-sculptor Alli Eynon. The lot includes two biscuit-foam bust lifecasts of Keaton and Pfeiffer, and a hollow fibreglass cast of DeVito's head. The word "Lifesize" is handwritten in black pen along the front of Keaton's bust. Each lifecast exhibits wear from production use, including dirt marks, scuffs and remnants of black and brown foam from the casting process. The tip of the left ear on DeVito's lifecast has snapped off. Dimensions (Keaton's cast): 26 cm x 35 cm x 36 cm (10 1/4" x 13 3/4" x 14 1/2")

Estimate. £1,500 - 2,500



726
Set of 20 Hand-Drawn Storyboards Ω
Batman Returns (1992)

20 hand-drawn storyboards from the production of Tim Burton's superhero sequel *Batman Returns*. Production used storyboards to map out scenes and capture specific filming angles. These storyboards are rendered in ink, paint, pastel, and graphite on paper and vellum. Several are hand-numbered and feature annotations in the margins detailing the actions and angles for film. These storyboards exhibit some smudging and ink transfer with some pieces intentionally cut out from and attached to the pages by production. Dimensions (each): 28.75 cm x 23.5 cm (11.25" x 9.25") Sold without copyright; see copyright notice in the Buyer's Guide.

Estimate. £1,000 - 1,500



727
Set of 18 Hand-Illustrated Storyboards Ω
Batman Returns (1992)

18 hand-drawn sketch storyboards from the production of Tim Burton's superhero sequel *Batman Returns*. Batman (Michael Keaton) was trapped in the Batmobile as it rampaged across Gotham. This set of storyboards for the sequence is rendered in ink, paint, pastel, graphite, and other media on paper and vellum. They are hand-numbered and feature annotations in the margins detailing various actions and angles. These storyboards exhibit hole-punching, some smudging, and ink transfer with pieces intentionally cut out from and attached to several pages by production. Dimensions (each): 28.75 cm x 23.5 cm x 0.75 cm (11.25" x 9.25" x 0.25") Sold without copyright; see copyright notice in the Buyer's Guide.

Estimate. £1,000 - 1,500



728
Two-Face's (Tommy Lee Jones)
Oversized Decision Coin \mathcal{M}
Batman Forever (1995)

Two Face's (Tommy Lee Jones) oversized decision coin from Joel Schumacher's superhero sequel *Batman Forever*. The double-headed coin was Two-Face's most prized possession, which the villain used in several scenes throughout the film to determine the fate of his victims. This oversized version was created for close-up shots of the coin's face when it landed after being flipped. Cast from metal, both sides of the faux-silver coin feature the Statue of Liberty's face and the text "E Gothamus Unum". One side is disfigured by several deep scratches. Dimensions: 6.5 cm x 6.5 cm x 0.5 cm (2 1/2" x 2 1/2" x 1/4")

Estimate. £1,000 - 1,500



729
Gossip Gerty's (Elizabeth Sanders) Glasses Ω
Batman Forever (1995)

Gossip Gerty's (Elizabeth Sanders) glasses from Joel Schumacher's superhero sequel *Batman Forever*. Gossip Gerty, Gotham's preeminent gossip columnist, interviewed Edward Nygma (Jim Carrey), aka the Riddler, about Bruce Wayne (Val Kilmer). Sanders was the wife of *Batman* co-creator Bob Kane and appeared in cameos throughout the franchise. These custom-made glasses feature translucent yellow plastic frames with winged tips embedded with sequins and curved temples. Also included is a gold-colour, velvet-lined Christian Dior Lunettes glasses box. The lenses and box exhibit scratching from production wear. Dimensions (box): 16 cm x 8.25 cm x 6.5 cm (6.25" x 3.25" x 2.5")

Estimate. £1,200 - 1,800



730
Set of The Riddler's (Jim Carrey) Apartment Items \mathcal{M}
Batman Forever (1995)

A selection of The Riddler's (Jim Carrey) apartment items from Joel Schumacher's superhero sequel *Batman Forever*. Various memorabilia featuring The Guesser character - the inspiration for The Riddler persona - filled Edward Nygma's apartment. The lot comprises a snowglobe with the Guesser character with tiny holographic glitter and small question mark emblems, two black plastic cups, and two different Guesser prop puzzle books containing unrelated filler pages. There are signs of creasing on one book cover, and a large bubble has formed at the top of the snowglobe. Dimensions (snowglobe): 12 cm x 12 cm x 15 cm (4 3/4" x 4 3/4" x 6")

Estimate. £600 - 800



732
Foldable Stunt Batarang $\dagger\Delta$
Batman Begins (2005)

A foldable stunt batarang from Christopher Nolan's superhero film *Batman Begins*. Batman (Christian Bale) used batarangs throughout the film to fight Gotham's villains. The batarang is made of dense rubber and painted with a bronze finish. It is split down the centre, and each half is held together with two small hinges with inbuilt magnets to lock it into the fully open position. Dimensions: 6.5 cm x 19.5 cm x 0.5 cm (2 1/2" x 7 3/4" x 1/4")

Estimate. £2,000 - 3,000



731
Two-Face Thug Mask,
Circus Programme and Popcorn Boxes \mathcal{M}
Batman Forever (1995)

A Two-Face Thug mask, circus programme and popcorn boxes from Joel Schumacher's superhero sequel *Batman Forever*. Two-Face's (Tommy Lee Jones) Thugs wore masks throughout the film and notably accompanied him to inflict terror at the Gotham Hippodrome's Charity Circus event. Circus audience members ate popcorn and held programmes as they watched the Flying Graysons. The ski mask is made of black-and-red stretch fabric with eye and mouth holes, ad two separate metal faux piercing rings. Custom-made for production, the programme features a two-faced man on the cover and a performance schedule printed on the inside. Yellow-and-red striping and the same two-faced man emblem adorn the two cardboard popcorn boxes. Dimensions (programme): 27 cm x 20 cm (10 1/2" x 8")

Estimate. £400 - 600



733
Set of Wayne Enterprises Schematics $\dagger\Delta$
Batman Begins (2005)

A set of Wayne Enterprises printed schematics from Christopher Nolan's superhero film *Batman Begins*. Various designs for high-tech items were seen on the desk of Lucius Fox (Morgan Freeman), the head of the Applied Sciences division. The lot consists of six laminated A5-sized cards, each featuring designs and information for a grapple gun and harness. The schematics are split into two sets of three, are joined together via a metal keyring loop. Dimensions (each card): 15.5 cm x 21.5 cm (6" x 8 1/2")

Estimate. £1,000 - 1,500



734
Complete Viral Deck of Joker (Heath Ledger) Cards Ω
Dark Knight, The (2008)

A complete "viral deck" of Joker (Heath Ledger) cards from the promotion of Christopher Nolan's action thriller sequel The Dark Knight. 42 Entertainment and DC Comics released production-made decks of Joker's unique calling cards as part of its viral marketing campaign. These 47 specialty playing cards, an extremely rare complete set, are printed on textured semi-gloss cardstock and labelled either "Joker" or "J." Each features a distinct pattern on one side and a character image on the other, including gargoyles, dragons, and clowns, among others. Also included is the opened, original card box. Several cards exhibit bending. Dimensions (each): 9 cm x 6.5 cm (3.5" x 2.5")

Estimate. £2,500 - 3,500



735
The Joker's (Heath Ledger) Smoke Grenade M
Dark Knight, The (2008)

The Joker's (Heath Ledger) smoke grenade from Christopher Nolan's superhero sequel The Dark Knight. During the film's pivotal opening heist sequence, the Joker placed a smoke grenade in the mouth of the Bank Manager (William Fichtner). This black smoke grenade is made of rubber with a gun-metal clip and ring. It features a label tied to the ring, on which the film's code name "Rory's 1st Kiss" is handwritten in black pen. The grenade exhibits scratches and minor rusting from production use and age. Dimensions: 14.5 cm x 4 x 5.5 cm (5 3/4" x 1 1/2" x 2 1/2")

Estimate. £3,000 - 5,000



736
Drug Scheme
Bunny Toy M
Batman Begins (2005)

A drug scheme bunny toy from Christopher Nolan's superhero film Batman Begins. Headed by gang boss Carmine Falcone (Tom Wilkinson), drug runners concealed packets of drugs inside innocent-looking bunny toys. Falcone held a bunny that was not tampered with when he spoke to corrupt detective Arnold Flass (Mark Boone Junior) in the back of his limo. The soft plush toy features grey faux fur, brown-coloured eyes and stitching detailing on the nose. The underside of the ears, hands, and feet is a lighter brown, and this example does not bear any holes at the back, suggesting prop drugs were not inserted. Dimensions: 18 cm x 23 cm x 22 cm (7" x 9" x 8 3/4")

Estimate. £400 - 600



738
Set of Three The
Gotham Times
Newspapers Covers Ω
**Dark Knight,
The (2008)**

Three The Gotham Times newspaper covers from Christopher Nolan's action thriller sequel The Dark Knight. Gotham's local newspaper appeared as set dressing throughout the film, and were later distributed by Warner Bros. as promotional giveaways. This set consists of three production-made, black-and-white newspaper covers headlined "Harvey Dent Joins Race for Gotham DA," "City at War: Batman Saves Entire Family," and "Batman: Savior [sic] or Menace." Two covers feature photographs of Harvey Dent (Aaron Eckhart), and one features a photograph of Batman (Christian Bale) with additional stories on the interior pages. All exhibit horizontal fold lines. Dimensions (each): 29.25 cm x 31.75 cm (11.5" x 12.5")

**Estimate.
£1,200 - 1,800**

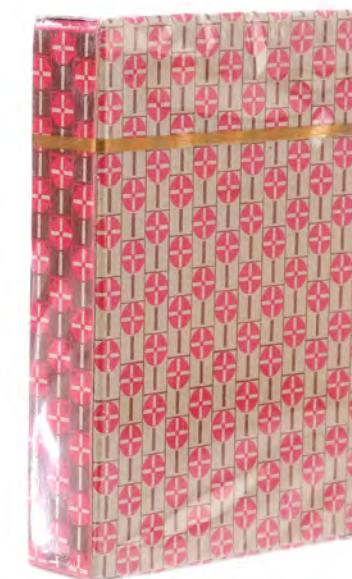

737
Joker's (Heath Ledger)
Sealed Card Deck Ω
**Dark Knight,
The (2008)**

Joker's (Heath Ledger) sealed card deck from Christopher Nolan's action thriller sequel The Dark Knight. The psychotic Joker planted his customized calling cards throughout the film, including with the car bomb that killed judge Surillo (Nydia Rodriguez Terracina). This complete, production-made deck of textured semi-gloss Joker cards remains sealed in its original clear plastic wrapping. Each card is printed with a distinct pattern on one side and a malevolent character image, such as gargoyles, dragons, and clowns, on the other. The full deck's bottom right corners exhibit some bending from handling. Dimensions: 6.5 cm x 9 cm x 1.5 cm (2.5" x 3.5" x 0.5")

**Estimate.
£1,200 - 1,800**



739
Squadron Leader
Canfield's (Michael
Caine) Pilot Life
Preserver $+$
**Battle Of
Britain (1969)**

Squadron Leader Canfield's (Michael Caine) pilot life preserver from Guy Hamilton's war film The Battle of Britain. Canfield wore his life preserver while defending the RAF airfields from the German raids. This orange P. Frankenstein & Sons Ltd. life preserver features the manufacturer's label, along with the patent number "689597" and a sewn-in costumer's label with Caine's name printed on it. The vest features cotton ties, a plastic whistle attached by a nylon cord, and a rolled collar that runs around the neck and down the front. The vest exhibits some wear from production use and age, including staining, faint fake blood marks on the collar, and rusting of the metal buckles.

**Estimate.
£2,000 - 3,000**



740
Group Captain Baker's
(Kenneth Moore)
RAF Uniform +
**Battle Of
Britain (1969)**

Group Captain Baker's (Kenneth Moore) RAF uniform from Guy Hamilton's war film *The Battle of Britain*. Baker wore his RAF uniform throughout the film, and was first seen on the Duxford Base during the "Eagle Day" attacks. This uniform includes a blue M. Berman Ltd. costumier's jacket, labelled size 40". It features brass buttons, a belt, a pilot's wings insignia sewn above the top left pocket, and a striped rank braid fastened above each cuff. A label is sewn to the interior with "Kenneth More, Jacket 1 B.O.B" printed on it, as well as "Plaza" handwritten in blue. The jacket is missing Baker's medal ribbons, which were fastened below his pilot wings. The uniform also includes a pale blue shirt, labelled size 16", and a slim black cotton tie. The jacket exhibits small holes and abrasions from production use, including a tear along the front left hem.

Estimate.
£2,000 - 3,000



742
Miniature
Floral Sculpture M
Beetlejuice (1988)

A miniature floral sculpture from Tim Burton's horror comedy *Beetlejuice*. Floral sculptures were prized possessions of Delia Deetz (Catherine O'Hara). Painted blue and grey, this miniature model featured in a stop-motion scene, in which some of Delia's floral sculptures came to life during the wedding ceremony of Lydia (Winona Ryder) and Betelgeuse (Michael Keaton). The sculpture is made of resin, metal, wood and acrylic, and mounted on a black display stand made of wood and plastic. The sculpture exhibits some exposed materials, chipping and fissures. Dimensions: 28 cm x 15.5 cm x 15.5 cm (11" x 6 1/4" x 6 1/4")

Estimate.
£1,500 - 2,500



741
Belle's (Emma Watson)
Hairpin Lock Pick + Δ
**Beauty And
The Beast (2017)**

Belle's (Emma Watson) hairpin lock pick from Bill Condon's live-action adaptation of Disney's *Beauty and the Beast*. Belle wore several leaf-inspired hairpins with her iconic yellow gown during her dance with the Beast (Dan Stevens). Later, Maurice (Kevin Kline) used one of her hairpins to pick the lock on the carriage he and Belle had been trapped in by Gaston (Luke Evans). The hairpin is made of thin metal with one end featuring a decorative curved leaf emblem with vein detailing on one side. There are some signs of scratches on the feather. Dimensions: 14 cm x 3 cm x 0.5 cm (5 1/2" x 1 1/4" x 1/4")

Estimate.
£800 - 1,200

743
Framed Flyer
Concept Artwork M
Beetlejuice (1988)



A concept artwork from the production of Tim Burton's 1988 comedy horror *Beetlejuice*. The artwork relates to a flyer advertising Betelgeuse's (Michael Keaton) bio-exorcism services, which fell out of the Handbook for the Recently Deceased that Adam and Barbara Maitland (Alec Baldwin and Geena Davis) were reading. The artwork is rendered in pencil and coloured ink on paper. It is displayed in a wooden frame behind an acrylic pane, with metal hanging wire at the rear. Accompanying the drawing and set within the frame are two stills from the film: one depicting the scene where the flyer appeared, and the other featuring a smiling Betelgeuse. The film title is engraved underneath the stills on a black display board. Dimensions: 88 cm x 47 cm x 2.5 cm (34 3/4" x 18 1/2" x 1") Sold without copyright; see copyright notice in the Buyer's Guide.

Estimate.
£1,000 - 1,500

744
No Lot



746
Isabel Bigelow's (Nicole Kidman)
Broomstick M
Bewitched (2005)

Isabel Bigelow's (Nicole Kidman) broomstick from Nora Ephron's romantic comedy *Bewitched*. Isabel carried her broomstick in multiple scenes throughout the film, most notably when she revealed to Jack Wyatt (Will Ferrell) that she was a real witch and used her powers to levitate him. The broomstick comprises a detailed lacquered wooden shaft with a metal armature and straw bristles. The straw head is woven tightly at the top and attached to the handle via string. Markings and knot-like detailing have been added to the wood to create an aged appearance. There are signs of damage on the shaft and visible glue remnants where the top of the head and shaft are adjoined. Dimensions: 168 cm x 10 cm x 10 cm (66 1/4" x 4" x 4")

Estimate. £2,000 - 3,000



745
Papi (George Lopez) Stand-In Ω
Beverly Hills Chihuahua (2008)

A Papi (George Lopez) stand-in from Raja Gosnell's family comedy *Beverly Hills Chihuahua*. Stand-in chihuahuas were created by production for times when a real dog was not needed or available. This dog stand-in features a polyfoam core painted to loosely match Papi and covered in latex over a wire frame. Its paws feature acrylic nails to complete the look. The lot exhibits scuffs and chips to the finish, red stains and other residue from props it was stored in contact with, and three missing toenails. Dimensions: 43.25 cm x 33.25 cm x 15.25 cm (17" x 13" x 6")

Estimate. £600 - 800



747
Pair of "The Boston Globe" Newspapers M
Black Mass (2015)

A pair of newspapers from Scott Cooper's biographical crime drama *Black Mass*. Billy Bulger (Benedict Cumberbatch) read about his criminal brother Whitey's (Johnny Depp) lottery win in one newspaper, and the other revealed Whitey's work as an FBI informant. The lottery newspaper features just a cover page and the informant newspaper is wrapped around a printed copy of the *Globe*. Both feature a large picture of Whitey. The newspapers have been folded and feature creases. Dimensions (folded): 30 cm x 38 cm (11 3/4" x 15")

Estimate. £500 - 700

748
Cast-Autographed
"Smokey Putnum (No. 30)" Bound Script Ω
Blacklist, The (T.V. Series, 2013 - 2022)

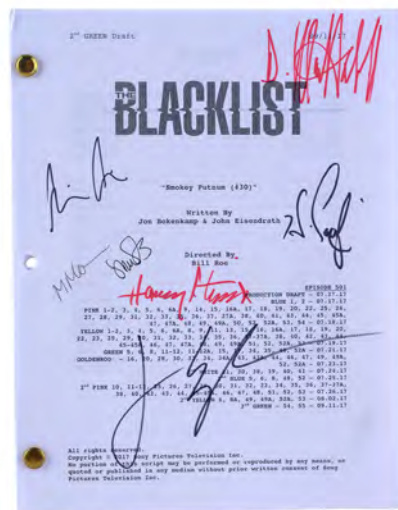

A cast-autographed script for the Season 5 episode "Smokey Putnum (No. 30)" of Jon Bokenkamp's crime series The Blacklist. In the episode, Red Reddington (James Spader) tracked down Blacklister Smokey Putnum (Michael Aronov). This brass brad-bound, 55-page production script - the second green draft dated "09.11.17" - is signed on front by Spader, Megan Boone ("Elizabeth Keen"), Harry Lennix ("Harold Cooper"), Diego Klattenhoff ("Donald Ressler"), Mozhan Marno ("Samar Navabi"), Hisham Tawfiq ("Dembe Zuma"), and Amir Arison ("Aram Mojtabai"). It is hole-punched and exhibits production-bent corners and includes a four-page "pronunciation guide" for various script terms at the back. Dimensions: 28 cm x 21.75 cm (11" x 8.5")

Estimate. £400 - 600

750
Framed
Liberator Blueprint Δ
Blake's 7 (T.V. Series, 1978 - 1981)

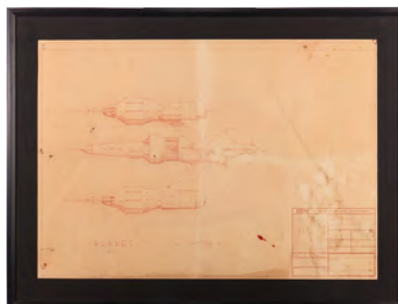

A framed blueprint of the Liberator from the production of BBC sci-fi television series Blake's 7. The alien spacecraft known as the Liberator appeared throughout the show's first three series. The print features a detailed top-down diagram of the spacecraft's exterior, and the sheet is labelled "The Liberator". An unfilled data field titled "BBC Television Design Department" is situated in the bottom right corner. Presented in a black frame, the blueprint has become discoloured over time and exhibits several marks, minor tears and creasing. Dimensions (displayed): 72.5 cm x 97 cm x 2 cm (28 1/2" x 38 1/4" x 3/4") Sold without copyright; see copyright notice in the Buyer's Guide.

Estimate. £600 - 800



749
Reinhardt's
(Ron Perlman)
Skull Bomb Δ
Blade 2 (2002)

Reinhardt's (Ron Perlman) skull bomb from Guillermo del Toro's action-thriller sequel Blade II. Blade (Wesley Snipes) attached a bomb to the base of his rival Reinhardt's skull to keep him in line. The device is made predominantly of brass and steel. It features a sharp, pointed "injector" at its centre, and four pincers for digging into the skin. The injector can be depressed using a plunger on the device. The bomb has some tarnishing to the metal and light surface scratches. Dimensions: 9.5 cm x 4.5 cm x 3.5 cm (3 3/4" x 1 3/4" x 1 1/4")

Estimate. £800 - 1,200

751
Blues Brothers
Prop Poster M
Blues Brothers, The (1980)



A Blues Brothers prop poster from John Landis' musical comedy The Blues Brothers. Posters like this were distributed when Jake (John Belushi) and Elwood (Dan Aykroyd) drove around Chicago promoting their concert at the Palace Hotel Ballroom. Printed on cardboard, the poster features a colourful rainbow-gradient background, with black text reading "Tonight Only" across the top and "Back After 3 Years Fabulous Rhythm and Blues Revue" with the concert location at the bottom. A black graphic portrait of Jake and Elwood is featured at the centre, sandwiched between their names and the band's name. Dimensions: 56 cm x 35.5 cm (22" x 14") Sold without copyright; see copyright notice in the Buyer's Guide.

Estimate. £2,000 - 3,000



752
Set of "Best Actress" Academy Awards®
Envelopes and Winner Cards Ω
Bodyguard, The (1992)

A set of "Best Actress" Academy Awards® envelopes and winner cards from Mick Jackson's romantic thriller The Bodyguard. Frank (Kevin Costner) ran onto the stage at the Academy Awards® ceremony and took a bullet for Rachel Marron (Whitney Houston) as she walked on stage to accept the award for Best Actress. The lot comprises six cream-coloured envelopes, each featuring "Best Actress" printed on the front and a metallic red paper seal on the back. Inside the envelopes are cards featuring Rachel's name and "Queen of the Night", the film she was nominated for. One of the cards features the text in gold-foil lettering, and the other displays black printed text. Two envelopes are open, while the remaining four are sealed, and the two open examples exhibit marks. Dimensions (each envelope): 13.5 cm x 18.5 cm (5 1/4" x 7 1/4")

Estimate. £1,000 - 1,500



754
Autographed "I Will Always Love You" Note M
Bodyguard, The (1992)

A note inscribed "I Will Always Love You" autographed in black ink by one of the best-selling recording artists of all time, Whitney Houston. Written by Dolly Parton, Houston recorded her version of the song "I Will Always Love You" for the soundtrack to Mick Jackson's romantic thriller The Bodyguard and her character Rachel Marron performs the ballad in the film's closing scene. Houston has autographed this note as "Whitney B." She only signed as "Whitney B" for a brief time whilst married to Bobby Brown. Dimensions: 21 cm x 21.5 cm (8 1/4" x 8 1/2") A portion of the hammer proceeds from this item are being donated to the National Autistic Society.

Estimate. £600 - 800



753
"Best Song" Academy Awards®
Envelopes and Winner Card Ω
Bodyguard, The (1992)

Two "Best Song" Academy Awards® envelopes and a winner card from Mick Jackson's romantic thriller The Bodyguard. Rachel Marron (Whitney Houston) froze and ran off stage whilst presenting the award for "Best Song" at the Academy Awards® ceremony with Clive Healy (Nathaniel Parker). The text on this version of the winner card differs from the insert in the final cut of the film. The two sealed cream-coloured envelopes feature "Best Song" printed on the front and a metallic red paper seal on the back. The winner's card displays the song title, "I Have Nothing", and composer names. Dimensions (each envelope): 13.5 cm x 18.5 cm (5 1/4" x 7 1/4")

Estimate. £800 - 1,200



755
Set of Three 'Rachel Marron's
Greatest Triumph!' Screen Lives Magazines Ω
Bodyguard, The (1992)

A set of three "Rachel Marron's Greatest Triumph!" Screen Lives magazines from Mick Jackson's romantic thriller The Bodyguard. A copy of Screen Lives magazine featuring actress and singer Rachel Marron (Whitney Houston) on the cover is seen on the table when her stalker Dan (Tony Pierce) created a threatening ransom-style letter. The production-made magazine covers all feature an image of Rachel sitting in a limousine with the headline "Rachel Marron's Greatest Triumph!" printed in a yellow box in bold text. The interior pages in all three examples are from an issue of Star tabloid magazine. One of the front covers exhibits a small tear. Dimensions (each): 30 cm x 25 cm x 0.2 cm (11 3/4" x 9 3/4" x 1/4")

Estimate. £800 - 1,200



756
Collection of Threatening Letters and Fan Mail
Bodyguard, The (1992)

A collection of threatening letters and fan mail from Mick Jackson's romantic thriller The Bodyguard. Frank Farmer (Kevin Costner) was hired as a bodyguard for actress and singer Rachel Marron (Whitney Houston) after she started receiving multiple threatening letters from a stalker. Although ultimately not clearly seen in the final cut of the film, Frank sifted through several letters when he first attended Rachel's house. The lot consists of an assortment of handwritten, printed and ransom-style cut and paste letters; 60 envelopes addressed to Rachel; and a package containing a voodoo doll. Some letters exhibit torn edges, and one sheet has been intentionally burnt. Dimensions (larger letters): 28.5 cm x 21.5 cm (11 1/4" x 8 1/2")

Estimate. £600 - 800



758
Rachel Marron (Whitney Houston)
CDs and Backstage Passes
Bodyguard, The (1992)

A set of Rachel Marron (Whitney Houston) CDs and backstage passes from Mick Jackson's romantic thriller The Bodyguard. Rachel Marron was an Academy-Award® nominated actress and music superstar receiving death threats from a stalker. These CDs and passes were made for the production but ultimately not seen in the final cut of the film. The lot comprises an "All Access" CD case; a "Touch" CD case; a "Cross Overs World Tour 92" CD case containing a disc featuring Rachel's name; and three laminated "Cross Overs World Tour 92, All Access" backstage passes. One of the CD covers displays minor discolouration. Dimensions (each CD): 12.5 cm x 14.25 cm x 1 cm (5" x 5 3/4" x 1/2")

Estimate. £600 - 800



757
Kevin Costner's Chair Back
Bodyguard, The (1992)

Kevin Costner's chair back from the production of Mick Jackson's romantic thriller The Bodyguard. Cast and crew use distinctive 'director's chairs' on set when resting between takes. Made from thick green canvas fabric, the chair back displays the film title printed on white on one side and text reading "Kevin Costner" on the other. There is a notable mark on the side featuring Costner's name. Dimensions: 17 cm x 55 cm x 1 cm (6 3/4" x 21 1/2" x 1/2")

Estimate. £600 - 800



759
Collection of Squirrel Hill Productions Memos and Paperwork
Bodyguard, The (1992)

A collection of Squirrel Hill Productions memos and paperwork from Mick Jackson's romantic thriller The Bodyguard. Staff carried paperwork in the rehearsal room in Rachel's (Whitney Houston) house, where she first met Frank (Kevin Costner), and an assistant held a folder full of memos when she handed Rachel paperwork to review. The lot comprises 15 memos; seven copies of a real estate authorisation form, three copies of a franchise approval form, five copies of a typed letter addressed to "Jackie" from Rachel, two sheets of grey "Squirrel Hill Productions" headed paper, and two grey "Squirrel Hill Productions" envelopes. Dimensions (each memo): 28 cm x 21.5 cm (11" x 8 1/2")

Estimate. £400 - 600



760
Frank Farmer's (Kevin Costner) Luggage Bags
Bodyguard, The (1992)

Frank Farmer's (Kevin Costner) luggage bags from Mick Jackson's romantic thriller The Bodyguard. Frank is seen carrying two luggage bags when he gets out of a taxi and heads into his home near the beginning of the film. The brown leather bag features two handles, a metal zip fastening along the top and comes with a long detachable strap. Also included in the lot is a large beige canvas bag which was ultimately not seen in the final cut of the film. There are signs of wear to the leather, and both bags exhibit marks. Dimensions (larger bag): 110 cm x 36 cm x 47 cm (43 1/4" x 14 1/4" x 18 1/2")

Estimate. £400 - 600



762
Three Borrowers Costumes
and Pod Clock's (Jim Broadbent) Spoon Gadget
Borrowers, The (1998)

Three costumes and Pod Clock's (Jim Broadbent) spoon gadget from Peter Hewitt's family adventure film The Borrowers. The Clocks wore their costumes - made from 'borrowed' household scraps - throughout the film. Pod used his spoon gadget to jam an ice cube dispenser and rescue Arrietty Clock (Flora Newbigin), after she became trapped in a freezer. This lot comprises Pod's jersey undershirt and his set of leather overalls and shoes; Homily Clock's (Celia Imrie) patchwork dress, featuring the actress' name handwritten on a costumer's label; Peagreen Clock's (Tom Felton) jumpsuit and jacket; and Pod's spoon gadget. The spoon gadget is made from a mix of materials and objects, including a teaspoon, a zipper, an elastic band and a hacksaw blade. This blade springs up from the stem of the spoon at a 90-degree angle when the wooden hinge holding it in place is released. The lot exhibits intentional distressing, with further staining, fraying and rusting from production use and age. Dimensions (spoon gadget): 177 cm x 50 cm x 25 cm (69 3/4" x 19 3/4" x 9 3/4")

Estimate. £1,000 - 1,500



761
Kevin Costner Autographed One-sheet Poster
Bodyguard, The (1992)

An autographed poster from the promotion of Mick Jackson's romantic thriller The Bodyguard. The one-sheet poster is printed on glossy paper and features Frank Farmer (Kevin Costner) carrying Rachel Marron (Whitney Houston) in the pouring rain. It is autographed in silver-coloured ink by Costner and displays the tagline "Never let her out of your sight, Never let your guard down, Never fall in love". The poster displays light creasing, tape remnants and a torn edge along the top, and photographic evidence of Costner signing the lot is included. Dimensions: 100.5 cm x 68.5 cm (39 1/2" x 27") A portion of the hammer proceeds from this item are being donated to the National Autistic Society.

Estimate. £300 - 500



763
Jason Bourne's (Matt Damon) Jacket
Bourne Supremacy, The (2004)

Jason Bourne's (Matt Damon) jacket from Paul Greengrass' action sequel The Bourne Supremacy. In a flashback, Bourne wore his jacket when he carried out his first assassinations on Conklin's (Chris Cooper) orders. This navy blue fabric blend jacket was custom-made by production as a wardrobe extra. It features a metal zipper closure, two side pockets, and cinching straps on the wrists. Also included is a wardrobe tag hand-marked "Bourne," "Flashback," "Extra Piece Chg. 1," and "M.D." for Matt Damon. The jacket exhibits some staining from production.

Estimate. £1,500 - 2,500



764
Jason Bourne's (Matt Damon)
Commandeered Greek Police Motorcycle
Jason Bourne (2016)

Jason Bourne's (Matt Damon) Greek police motorcycle from Paul Greengrass' action-thriller sequel Jason Bourne. Bourne rode this motorcycle through a riot in Athens, after stealing it from a police officer. He then used it to fight off police and The Asset (Vincent Cassel), before rescuing Nicky (Julia Stiles). The motorcycle is a 2015 Husqvarna FE 450 modified with front blue police lights, a rear police light stand that was damaged for the production, a rear carrying case, and one pannier. It features a white body decorated with Greek police decals, including their emblem on the pannier; a pair of spare panniers with an undamaged police light stand; and a spare front vent cover. The motorcycle also displays a handwritten label in front of the seat reading "JB stunt hero bike 1" and comes with the UK licence plate "HS15 EVW". It has a 449.3 cc 1-cylinder 4-stroke engine, is powered by unleaded petrol and its VIN number is VBKUA401FM362384. As this is a functioning vehicle, legal transfer of title will need to take place before delivery can be arranged. Dimensions: 220 cm x 146 cm x 81 cm (86 1/2" x 57 1/2" x 32") Special shipping required: see special shipping notice in the Buyer's Guide. Contains electronics; see electronics notice in the Buyer's Guide.

Estimate. £2,000 - 3,000



766
Hero War Hammer
Braveheart (1995)

A hero war hammer from Mel Gibson's historical epic Braveheart. Scottish warriors, including William Wallace (Gibson), carried war hammers into battle against the English. The weapon has a wooden handle and a heavy steel head. It has some wear from age, including rust on the head, and some cracks on the wooden handle. Dimensions: 70 cm x 24.5 cm x 4 cm (27 1/2" x 9 3/4" x 1 1/2")

Estimate. £800 - 1,200



765
Hand-Painted Matthew
Yurich Brainstorm Lab Matte Painting
Brainstorm (1983)

A matte painting of the Brainstorm lab hand-painted by matte artist Matthew Yurich for Douglas Trumbull's sci-fi film Brainstorm. Michael (Christopher Walken) and Karen Brace (Natalie Wood) vowed to stay married in the Brainstorm lab. This matte painting of the lab's exterior at night is rendered in mixed media on particle board labelled "BS" with tape in the top right corner. It exhibits paint stains and smudging, and the board is fractured and chipped along the edges. Dimensions: 203.25 cm x 96.5 cm x 1.5 cm (80" x 38" x 0.5") Sold without copyright. See notice in the Buyer's Guide. Special shipping required; see notice in the Buyer's Guide.

Estimate. £400 - 600



767
Two Pairs
of English Soldiers'
Tunics and Helmets
Braveheart (1995)

Two pairs of English soldiers' tunics and helmets from Mel Gibson's historical epic Braveheart. English soldiers wore tunics and helmets throughout the film as William Wallace (Mel Gibson) led his Scottish brethren against King Edward Longshanks' (Patrick McGouhan) invading army. The costumes were designed by Charles Knode, who was nominated for an Academy Award® for his work on the film. This lot consists of two orange burlap fringed sleeveless tunics, both with gold-colour lion emblems painted on front, as well as two grey fibreglass helmets, both with leather chin straps and one padded with foam. One tunic exhibits blood-staining by production, and both helmets exhibit chipping from wear.

Estimate. £800 - 1,200



768
Jesse Pinkman's
(Aaron Paul) "Felina" Shoes
Breaking Bad
(T.V. Series, 2008 - 2013)

Jesse Pinkman's (Aaron Paul) shoes from the final episode of the thrilling television series Breaking Bad. Jesse wore these shoes when captured by the Neo-Nazi gang, forced to make meth until he is eventually freed by Walter (Bryan Cranston) in the show's finale "Felina". The shoes (size US9/UK8) are Supra® "The Infamous" skating trainers with a camouflage print and black laces; they show minor scuffs and dirt from use on set.

Estimate. £1,000 - 1,500



769
Walter White's
(Bryan Cranston) Costume
Breaking Bad
(T.V. Series, 2008-2013)

Walter White's (Bryan Cranston) costume from Vince Gilligan's crime-thriller TV series Breaking Bad. Walter wore his ensemble at the beginning of the Season 5 episode "Say My Name", when he met with the Phoenix meth distributors. He was also seen sporting the jacket in the episode "Rabid Dog" and the trousers in "Blood Money". This costume consists of a black London Fog jacket (size L) with plastic zips and metal fasteners on the wrists; a pair of grey chino trousers (W34 L32); and a pair of black leather wallabee shoes (UK 10 1/2). Both the jacket and the trousers feature "WALT" handwritten in black ink on their interiors, and each item comes with an official Breaking Bad certificate of authenticity.

Estimate. £800 - 1,200



770
Walter White's (Bryan Cranston)
Tan Windbreaker
Breaking Bad (T.V. Series, 2013)

Walter White's (Bryan Cranston) tan windbreaker from Vince Gilligan's crime thriller series Breaking Bad. Walter wore his signature windbreakers, some tan and some black, throughout Season 5. This tan polyester zip-up Jos. A. Bank Traveler's [sic] Collection windbreaker (size L) features blue herringbone-patterned cotton lining on the interior, two front side pockets, and dual faux tortoiseshell buttons on each wrist. It exhibits light staining on the right lapel and back from production.

Estimate. £3,000 - 5,000



771
 Walter White's Underwear
Breaking Bad
 (T.V. Series, 2008 - 2013)

Walter White's underwear from Vince Gilligan's crime thriller series Breaking Bad. White (as played by Bryan Cranston) wore his iconic tighty-whities throughout the series, beginning when he first cooked crystal meth with Jesse Pinkman (as played by Aaron Paul) in the pilot episode. Matching underwear also appeared in White's closet throughout the series.

This pair of white men's cotton and polyester Towncraft briefs (size 40) features a white elastic waistband with blue and goldenrod details, though the elasticity is largely lost and there are tears along the left leg from wear and age.

Estimate. £3,000 - 5,000



772
 Pair of Walter White's
 (Bryan Cranston) Cell Phones
Breaking Bad
 (T.V. Series, 2008 - 2013)

Walter White's cell phones from Vince Gilligan's crime thriller series Breaking Bad. Walt used and destroyed a variety of secret phones throughout the series to operate his crystal meth business as Heisenberg. These two matching chrome-colour and black Kyocera Qualcomm 3C CDMA flip phones are both labelled with "Virgin Mobile" as their providers. Also included is a Sony Certificate of Authenticity. The pair exhibits scratching and staining from production use, and both are currently nonfunctional. Dimensions (each): 18 cm x 5 cm x 1 cm (7" x 2" x 0.5") Contains electronic components; see notice in the Buyer's Guide.

Estimate. £1,000 - 1,500



773
 Bag of Blue Sky Meth
Breaking Bad
 (T.V. Series, 2008 - 2013)

A bag of Blue Sky meth from Vince Gilligan's crime thriller series Breaking Bad. Walter White (as played by Bryan Cranston) and Jesse Pinkman (as played by Aaron Paul) manufactured their famously potent crystal meth - also known as "Blue Magic" and "Big Blue" - throughout the series, and loaded it into large baggies for drug lord Gus Fring (as played by Giancarlo Esposito) throughout Season 4.

This lot consists of approximately one pound of jagged blue silicone crystals inside a gallon-size plastic Ziploc bag labelled "Breaking Bad: Large bags of blue meth (silicon) [sic]." It is a prop and unsafe for consumption. Dimensions (bagged): 24.25 cm x 20.5 cm x 9 cm (9.5" x 8" x 3.5")

Estimate. £800 - 1,200



774
 Set of Montgomery
 Brewster's (Richard Pryor) Ephemera
Brewster's Millions (1985)

Montgomery Brewster's (Richard Pryor) ephemera from Walter Hill's classic comedy Brewster's Millions. In an attempt to inherit \$300 million, Hackensack Bulls pitcher "Monty" Brewster staged a match against the New York Yankees, ran for Mayor, and bought a rare misprinted stamp. This set consists of a glossy colour Yankees vs. Bulls brochure; four orange and blue uncut paper postage stamps printed with an upside-down biplane; two New York Poster newspapers with production-made covers, one featuring Brewster's stamp and one headlined "None of the Above"; and an enamel "Don't Vote for Brewster" campaign pin. The set exhibits signs of production use throughout, including edge wear and folding to the papers and brochure. Dimensions (largest): 29.25 cm x 38.25 cm (11.5" x 15"); (smallest): 10.25 cm x 10.25 cm (4" x 4")

Estimate. £1,500 - 2,500



776
 Fornicus' (Greg Zach) Puzzle Orb and RV Plate
Cabin In The Woods, The (2011)

Fornicus' (Greg Zach) puzzle orb and RV plate from Drew Goddard and Joss Whedon's horror comedy The Cabin in the Woods. Dana Polk (Kristen Connolly) escaped from the cabin with the RV, and later saw Fornicus with his puzzle orb. This lot consists of a cast resin orb with magnetised, removable parts, alchemical carvings, and silver-colour detailing, as well as an aluminium licence plate numbered "071645" and hand-labelled "Motor Home" on the reverse. Both exhibit some discolouration and scuffing from production. Dimensions (orb): 10.25 cm x 10.25 cm (4" x 4" x 4"); (plate): 30.5 cm x 16 cm (12" x 6.25")

Estimate. £2,000 - 3,000

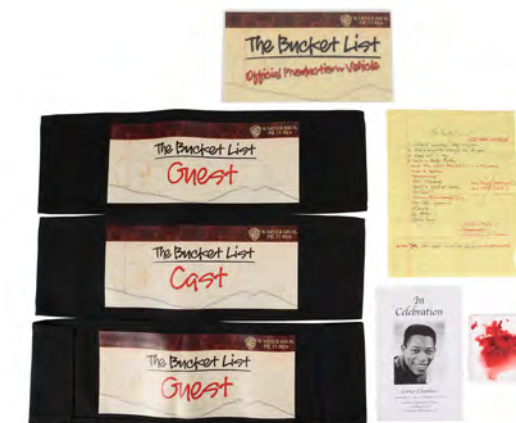

775
 Edward Cole's (Jack Nicholson)
 Screen-matched Bloodied Handkerchief, Bucket
 List Page, Funeral Flyer, and Production Ephemera
Bucket List, The (2007)

Edward Cole's (Jack Nicholson) screen-matched bloodied handkerchief, bucket list page, funeral flyer, and ephemera from the production of Rob Reiner's comedy-drama The Bucket List. Terminally ill billionaire Edward and mechanic Carter Chambers (Morgan Freeman) agreed to tick off items on their "bucket list" together before "kicking the bucket." This handkerchief's blood spatter screen-matches to the opening scene. The lot also includes a bucket list page seen throughout the movie; three production chairbacks; and a laminated Warner Bros. "Official Production Vehicle" card. The page exhibits intentional crumpling and taped-up tears. Dimensions (list): 27 cm x 21.5 cm (10 3/4" x 8 1/2")

Estimate. £800 - 1,200



777
 'Noland Alive!' Newspaper and People Magazine
Cast Away (2000)

A "Noland Alive!" newspaper and a copy of People magazine from Robert Zemeckis' drama Cast Away. Kelly (Helen Hunt) had a pile of newspapers and magazines on her kitchen table detailing plane-crash survivor Chuck Noland's (Tom Hanks) rescue from a desert island. The newspaper features the headline "Noland Alive" with a large picture of a bedraggled Noland. The accompanying article concerns the plane crash seen earlier in the film. The magazine cover features a picture of Noland, the headline "Noland Returns to Memphis After 60 Months at Sea", and pictures of the deceased aeroplane crew. The newspaper has been folded and features some discolouration. Dimensions (newspaper, folded): 32 cm x 36 cm (12 1/2" x 14 1/4")

Estimate. £2,000 - 3,000



778
 'Noland Comes Home'
 Newspaper and Newsweek Magazine Ω
Cast Away (2000)

A "Noland Comes Home" newspaper and a copy of Newsweek magazine from Robert Zemeckis' drama Cast Away. Kelly (Helen Hunt) had a pile of newspapers and magazines on her kitchen table detailing Chuck Noland's (Tom Hanks) escape from a desert island. The newspaper features two pictures of Noland beneath the headline "Noland Comes Home". The accompanying article details the plane crash seen earlier in the film. The magazine features a picture of Noland on the cover alongside the headline "The Fedex Mystery". The magazine also includes a couple of insert pages with additional pictures of Noland. The newspaper has been folded and features some discolouration. Dimensions (newspaper, folded): 32 cm x 36 cm (12 1/2" x 14 1/4")

Estimate. £2,000 - 3,000

779
 Winged FedEx Box and Production Photograph Ω
Cast Away (2000)

A winged FedEx box and production photograph from Robert Zemeckis' survival drama Cast Away. While stranded on a desert island, Chuck Noland (Tom Hanks) saved one unopened FedEx box with angel wings painted on it. After eventually escaping the island, he later delivered it to its intended recipient. This white cardboard box features FedEx logos, a barcode sticker, an adhesive plastic pouch containing shipping information, and a pair of hand-painted gold-coloured angel wings with three blue halos around them. The sealed box is intentionally distressed with dents, scuffing and staining. Also included is a Polaroid (marked "230") of Noland's FedEx box leaning against the door where he leaves it during the film's finale. Dimensions (box): 31.5 cm x 45.5 cm x 8 cm (12 1/2" x 18" x 3 1/4")

Estimate. £2,000 - 3,000

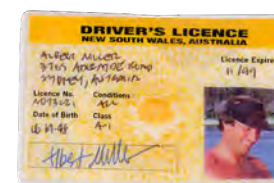
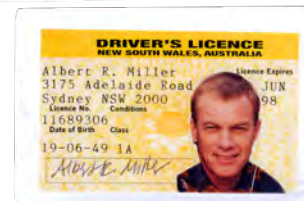
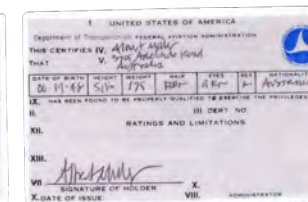
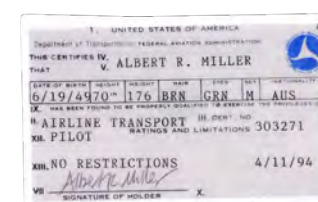
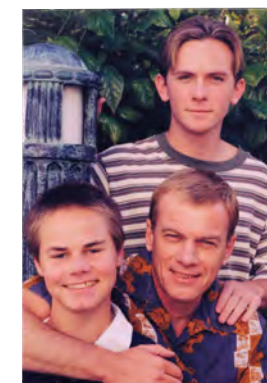
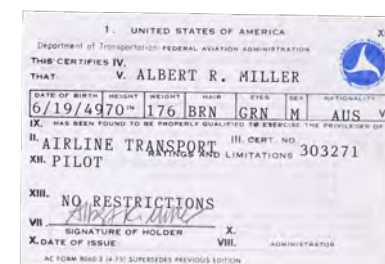
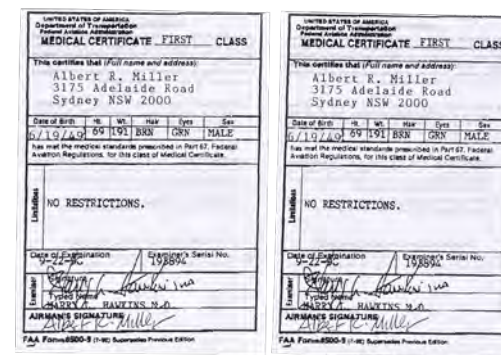

780
 Albert Miller (Vince Martin) IDs Ω
Cast Away (2000)

Albert Miller (Vince Martin) IDs from Robert Zemeckis' survival drama Cast Away. Shortly after the plane crash, pilot Al's body washed ashore along with several FedEx packages. Chuck (Tom Hanks) then searched his corpse and found his wallet which contained IDs and a family photo. This lot consists of two paper medical certificates, three transport IDs (two of which are laminated), two laminated Australian driver's licences, and one family photo. Dimensions (photo): 9 cm x 6 cm (3 1/2" x 2 1/4")

Estimate. £300 - 500

781
 Charlie Chaplin's (Robert Downey Jr.) Cane Ω
Chaplin (1992)

Charlie Chaplin's (Robert Downey Jr.) cane from Richard Attenborough's biopic Chaplin. Chaplin carried his cane in multiple scenes while playing the Tramp, most notably the one in which he impressed Hollywood comedy producer Mack Sennett (Dan Aykroyd). Chaplin created the iconic look of the Tramp after seizing several items from a communal male dressing room. Crafted from resin, the thin-ridged cane features a cast-in texture and is hand-painted in various shades of yellow and brown to resemble bamboo. The top end of the cane is curved to form a handle, while its tip features a brass-coloured metal cap. Dimensions: 87 cm x 10.5 cm x 2 cm (34 1/4" x 4 1/4" x 3/4")

Estimate. £3,000 - 5,000





782
Musical Dancing Marionette M
Charlie And The Chocolate Factory (2005)

A musical dancing marionette from Tim Burton's fantasy adventure Charlie and the Chocolate Factory. When the five lucky golden ticket recipients arrived at Willy Wonka's factory for their tour, they were greeted by an odd display of dancing animatronic puppets performing a welcome song. The exterior of this female puppet is made of fibreglass and has red hair. It is dressed in a pink floral dress and a white apron featuring the Wonka "W" logo. It holds a metal kitchen sieve in one hand, and "Sieve 7" is written in black ink on the back of its neck. Contained within the body are various servos and electrical components, which remain untested. The sieve shows signs of corrosion, and the garments exhibit marks. Dimensions: 36 cm x 43 cm x 82 cm (14 1/4" x 17" x 32 1/4") Contains electronic and mechanical components; see notice in the Buyer's Guide.

Estimate. £2,000 - 3,000



783
Golden Ticket and Fudgemallow Delight Wonka Bar M
Charlie And The Chocolate Factory (2005)

A golden ticket and Fudgemallow Delight Wonka Bar from Tim Burton's fantasy adventure Charlie and the Chocolate Factory. Five lucky children were given a tour of Willy Wonka's (Johnny Depp) factory after finding elusive golden tickets hidden in Wonka-bar wrappers. Printed on gold-coloured foil paper, the ticket displays an embossed stamp and text printed in black. The Wonka bar is made of injection-moulded brown plastic and is covered in silver foil, with a brown-coloured wrapper indicating its flavour. A printed seal on the front of the wrapper reads, "Win a trip to Wonka's Chocolate Factory". Marks are visible on the wrapper. Dimensions (ticket): 8 cm x 18 cm (3 1/4" x 7"); (bar): 9.5 cm x 19 cm x 1 cm (3 3/4" x 7 1/2" x 1/2")

Estimate. £2,000 - 3,000



784
Full-size Candy Cane Tree Branch M
Charlie And The Chocolate Factory (2005)

A full-size candy cane tree branch from Tim Burton's musical fantasy Charlie and the Chocolate Factory. Candy cane trees are dotted around the candy garden in Willy Wonka's (Johnny Depp) chocolate factory. The tree is made of resin and is finished in swirling white and red. The branch has some cracking at the base and shows signs of repair. The paint has faded in places and there is some paint transfer. Dimensions: 60 cm x 40 cm x 204 cm (23 1/2" x 15 3/4" x 80 1/4") Special shipping required; see special shipping notice in the Buyer's Guide.

Estimate. £2,000 - 3,000



786
Set of Four Wonka Bars M
Charlie And The Chocolate Factory (2005)

A set of four Wonka bars from Tim Burton's musical fantasy Charlie and the Chocolate Factory. Stacks of Wonka bars appeared in various locations around the globe as the world hunted for five elusive Golden Tickets. The bars are made of injection moulded brown plastic and feature a "Wonka" logo imprinted on each segment. Each bar is covered in silver foil and a colourful wrapper, indicating its flavour. The front of each bar features a printed seal reading, "Win a trip to Wonka's Chocolate Factory", and nutritional information is presented on the back. There are some glue remnants and minor staining on some of the bars. Dimensions (each bar): 9.5 cm x 18.5 cm x 1 cm (3 3/4" x 7 1/4" x 1/2")

Estimate. £1,000 - 1,500



785
Collection of Wonka Candy Props M
Charlie And The Chocolate Factory (2005)

A collection of candy props from Tim Burton's fantasy adventure Charlie and the Chocolate Factory. Wonka lollies hung from the ceiling of Willy Wonka's (Johnny Depp) old shop, while never-melting ice cream was sold outside by one of his competitors, and stacks of Wonka bars were sold around the world. A ladle was used by Wonka, Charlie (Freddie Highmore) and Grandpa Joe (David Kelly) during the chocolate riverboat ride. This lot consists of one biscuit-foam vanilla ice-cream scoop and waffle cone; two purple-tinted resin cups; a ladle featuring a seahorse-design handle; a packaged Wonka bar; and two red-tinted translucent resin lollies, each displaying a large "W". A section of the ice cream cone's tip has snapped off, and one of the lollies is missing its wooden handle. Some of the collection also exhibits glue remnants and minor staining. Dimensions (Wonka lolly): 28.5 cm x 19 cm x 1.5 cm (11 1/4" x 7 1/2" x 1/2")

Estimate. £1,000 - 1,500



787
Candy-cane Tree Stems M
Charlie And The Chocolate Factory (2005)

A collection of candy-cane tree stems from Tim Burton's musical fantasy Charlie and the Chocolate Factory. Candy-cane trees of various sizes were seen in Willy Wonka's (Johnny Depp) chocolate room. Canes similar to these were held by the Oompa Loompas during their Augustus Gloop (Philip Wiegatz) song. This lot comprises four candy-cane tree stems made of resin and painted with pink and white stripes. The two larger stems feature metal rods protruding from their base to help stabilise them when placed in the ground. The canes exhibit wear from production use, including small sections of exposed resin, a crack around the middle of one of the larger stems, and general staining. Dimensions (largest): 104 cm x 5 cm x 5 cm (41" x 2" x 2") Special shipping required; see special shipping notice in the Buyer's Guide.

Estimate. £800 - 1,200



788
Fencing Sword Ω
Charlie's Angels (2000)

A fencing sword from McG's action-comedy film Charlie's Angels. Alex Munday (as played by Lucy Liu) and her opponent used their swords while fencing during a montage introducing the film's titular heroines. This metal fencing sword features a long thin blade, a metal bellguard with red felt padding inside, a matching red grip wrap, and a metal pommel. The blade's point has a red rubber practice tip over it. The metal exhibits some scuffing and scratching from use and age. Dimensions: 108 cm x 14 cm x 14 cm (42.5" x 5.5" x 5.5")

Estimate. £400 - 600



789
Good Guy Doll Box &
Good Guy Doll Insert Ω
Child's Play 2 (1990)

A Good Guy doll box and a Good Guy doll insert from John Lafia's horror sequel Child's Play 2. Andy (Alex Vincent) and Kyle (Christine Elise) had to navigate a labyrinth of Good Guy doll boxes that filled the Play Pals Inc. factory whilst trying to escape Chucky (Brad Dourif). The lot consists of a large yellow cardboard box with a picture and various illustrations of the Good Guy doll alongside the tagline "He wants you for a best friend." Also included is a vacuum-formed plastic Good Guy doll insert, made by production to be placed behind the clear plastic windows on some of the doll boxes found in the factory instead of a real doll. These items exhibit wear from production use, including tears, creasing and abrasions on the cardboard packaging and scuffs on the chest of the doll insert. Dimensions (Box): 88 cm x 31 cm x 20 cm (34 3/4" x 12 1/4" x 8")

Estimate. £1,500 - 2,500

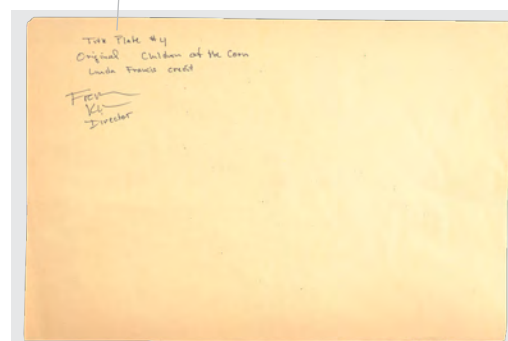
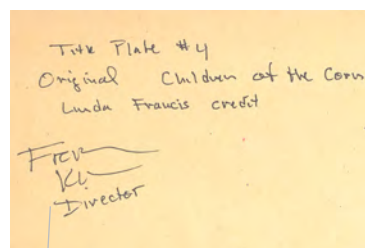

790
Fritz Kiersch-Signed
Hand-Drawn Sarah
(Anne Marie McEvoy) Illustration Ω
Children Of The Corn (1984)

A hand-drawn Sarah (Anne Marie McEvoy) illustration signed by Fritz Kiersch from Kiersch's classic horror film Children of the Corn. Sarah's macabre drawings of the Children appeared in the opening credits and her room during Burt's (Peter Horton) visit. One of five versions created by the art department, this illustration is rendered in crayon on brown drawing paper marked "and a child shall lead them" and inscribed "Title Plate #4 Linda Francis Credit" on the reverse by Kiersch. Included is a Letter of Authenticity from Kiersch. The paper exhibits some warping. Dimensions: 45.75 cm x 30.5 cm (18" x 12") Sold without copyright; see notice in the Buyer's Guide.

Estimate. £1,200 - 1,800



791
Christine Fuel Door M
Christine (1983)

A Christine fuel door from John Carpenter's adaptation of Stephen King's supernatural horror Christine. The eponymous 1958 Plymouth Fury was purchased by Arnie Cunningham (Keith Gordon), with the desire to fix the vehicle up - but Christine had other, darker intentions. This fuel door was created specifically for the special effects car, which was built for the scene where a heavily damaged Christine rebuilds herself. Special effects artist Roy Arbogast used hydraulics to crush the car inwards, and then the footage was reversed. The panel is made of solid rubber and painted in the car's signature red. "Christine Gas Door" is handwritten in black ink on the reverse. There are also remnants of adhesive on the reverse, where it was attached to the car. Dimensions: 14.5 cm x 18 cm x 1.5 cm (5 3/4" x 7" x 1/2")

Estimate. £3,000 - 5,000

792
Higbee's Window
Display Toy Airplane Ω
A Christmas Story (1983)

A Higbee's window display toy aeroplane from Bob Clark's comedy A Christmas Story. At the film's start, passersby revelled excitedly at a red biplane suspended in the window of a Higbee's Christmas display. Coming from a crew member, this biplane consists of wood, paper veneer, and a small metal engine. It features a straight-armed cross known as a "Balkenkreuz" that was introduced in 1916 and later became the emblem of the Wehrmacht. This lot has undergone sympathetic restoration to its wings and exhibits rust, wood chipping, and scratches from production and storage. Dimensions: 76.25 cm x 76.25 cm x 33.25 cm (30" x 30" x 13")

Estimate. £1,200 - 1,800

793
Minotaur Head Δ
**Chronicles Of Narnia: The Lion,
The Witch And The Wardrobe,
The (2005)**

A minotaur mask from Andrew Adamson's 2005 fantasy film The Chronicles of Narnia: The Lion, the Witch and the Wardrobe. Minotaurs fought on the side of the White Witch (Tilda Swinton). This mask and others like it were created by Howard Berger, who, along with Tami Lane, won an Academy Award® for his work on the film. The mask is made primarily of foam rubber around a resin helmet. It is covered with black faux fur and features two large foam-rubber horns and resin teeth. The foam rubber has cracked around the mouth, the left horn cap is cracked, and the right horn cap is no longer present.

Estimate. £2,000 - 3,000





794
Lucy Pevensie's (Georgie Henley) Costume and Jewellery Ω
Chronicles Of Narnia: The Voyage Of The Dawn Treader, The (2010)

Lucy Pevensie's (Georgie Henley) costume and jewellery from Michael Apted's fantasy-adventure sequel The Chronicles of Narnia: The Voyage of the Dawn Treader. Lucy changed out of her wet clothes and into this outfit after being rescued by the Dawn Treader. This costume consists of a pair of red leather, calf-height flat-heel boots labelled "Lucy Hero 2"; a custom-made cream-colour long-sleeved cotton peasant blouse with a "Lucy" tag; a silk double-breasted six-button vest; embroidered blue velvet jodhpurs with a handmade pocket pinned to the inside and a "Lucy 1 Bigger" tag; a leather belt with lacing labelled "Lucy Hero Belt"; a 14k gold charm bracelet; a colour-printed continuity photograph; and seven production tags. The costume exhibits mild discolouration, scuffing, and loose threads from wear.

Estimate. £2,500 - 3,500



795
Prince Caspian's (Ben Barnes) Costume Ω
Chronicles Of Narnia, The: The Voyage Of The Dawn Treader (2010)

Prince Caspian's (Ben Barnes) costume from Michael Apted's fantasy-adventure sequel The Chronicles of Narnia: The Voyage of the Dawn Treader. Caspian wore his costume when he investigated the Lone Islands. This costume consists of a long-sleeved purple cotton shirt; a damask-lined purple velvet jacket with slashed sleeves labelled "Pre Dungeon Caspian Fabric A Wider Neck 1 Neckline Hero"; brown jodhpurs labelled "Steel Caspian Hero Camera Friendly" with leather lacing; a pair of brown leather knee-length lace-up boots labelled "44 and a half Kile Gardenier [sic]"; a full-grain leather belt with debossed details and antiqued brass-coloured hardware; and one 22 cm x 28 cm (8" x 11") onset photograph. This costume exhibits loose buttons and frayed threads.

Estimate. £1,500 - 2,500



796
Edmund Pevensie's (Skandar Keynes) Costume and Baldric Ω
Chronicles Of Narnia: The Voyage Of The Dawn Treader, The (2010)

Edmund Pevensie's (Skandar Keynes) costume and baldric from Michael Apted's fantasy-adventure sequel The Chronicles of Narnia: The Voyage of the Dawn Treader. Edmund changed into his costume when the Dawn Treader rescued him. This lot consists of a brown and green leather suede long vest labelled "Edmund Hero 2"; purple silk waistcoat with 10 buttons labelled "Edmund Hero 2"; grey long-sleeved cotton shirt labelled "Edmund Narnia Shirt Bigger Stunt"; hand-made red and brown leather baldric with antiqued brass hardware and four embossed leather attachments; light brown fleece jodhpurs labelled "Edmund Hero 1"; and black calf-height boots. The costume exhibits loose buttons and thread, and scuffing on the leathers from production use.

Estimate. £1,200 - 1,800



797
Eustace Scrubb's (Will Poulter) Costume Ω
Chronicles Of Narnia: The Voyage Of The Dawn Treader, The (2010)

Eustace Scrubb's (Will Poulter) costume from Michael Apted's fantasy-adventure sequel The Chronicles of Narnia: The Voyage of the Dawn Treader. Eustace wore this costume when he approached the edge of Aslan's (Liam Neeson) country. This costume consists of a hand-made sky-blue cotton shirt labelled "Eustace Photo Double"; a satin-lined, steel-blue corduroy vest labelled "Eustace Photo Double"; olive green fleece jodhpurs labelled "Eustace Stunt"; a lace-up belt with stitched details; a pair of tan suede boots labelled "3 Jackson"; and one 22 cm x 28 cm (8" x 11") onset photograph. The jodhpurs exhibit mild discolouration and the boots minor scuffing.

Estimate. £1,200 - 1,800



799
Necromonger Costume Δ
Chronicles Of Riddick, The (2004)

A Necromonger costume from David Twohy's sci-fi sequel The Chronicles of Riddick. Necromonger infantrymen wore their armour throughout the film. The armour consists of a fibreglass helmet (marked "XL") with a foam-lined interior and a separate foam half mask; a balaclava; a rubber chest plate with attached pauldrons; a nylon bodysuit with a zip (marked size "L"); rubber rerebraces; leather gloves; a belt and codpiece (marked "L 107"); and leather boots (both marked "11 D"). The armour is painted grey with bronze accents, giving it a battle-worn appearance.

Estimate. £800 - 1,200



798
Hero Necromonger Pistol Δ
Chronicles Of Riddick, The (2004)

A hero Necromonger pistol from David Twohy's sci-fi sequel The Chronicles of Riddick. Necromongers used their pistols throughout the film as they battled Riddick (Vin Diesel) and his "breeder" allies. Made of resin, the futuristic weapon features highly ornate detailing and a tarnished steel and bronze-coloured metal-plated finish, in keeping with the design of Necromonger arms and armour. A small button located on the right side of the gun once powered a set of quick-firing strobe LEDs housed in the central chamber, which were activated by pulling the trigger. The electronics in the pistol no longer function. Dimensions: 28 cm x 18 cm x 6.5 cm (11" x 7" x 2 1/2") Contains electronics; see electronics notice in the Buyer's Guide.

Estimate. £1,500 - 2,500



800
Hand-painted Chris Achilleos Poster Concept Artwork Δ
Clash Of The Titans (1981)

Poster concept artwork hand-painted by illustrator Chris Achilleos for the promotion of Desmond Davis' fantasy adventure film Clash of the Titans. Achilleos was commissioned to create this artwork, but upon delivery, its packaging was opened using a razor, resulting in two subtle slices visible along its top and right sides. This gouache and oil pastel artwork depicting Perseus, Pegasus, and Medusa comes mounted on black paper adhered to thick card. Also included is a Letter of Authenticity. Dimensions (mounted): 79 cm x 54.5 cm (31" x 21 1/2") Sold without copyright; see notice in the Buyer's Guide.

Estimate. £2,000 - 3,000



801
Heavily Annotated Script,
Call Sheets and Production Paperwork **M**
Clash Of The Titans (1981)

A heavily annotated script, with call sheets and production paperwork from Desmond Davis' fantasy adventure Clash of the Titans. The script - credited to screenwriter Beverley Cross - is heavily annotated and highlighted throughout, including on the cover page, and also features pages of printed storyboards. The lot additionally includes 18 call sheets, 17 pages of location research photography, and other production ephemera, including shooting schedules, scene breakdowns, synopses, movement orders and handwritten notes. Many of the pages feature tears and staining. Dimensions (script): 28 cm x 22 cm x 2.5 cm (11" x 8 3/4" x 1")

Estimate. £600 - 800



803
Ghost Mask, Simon Paint
Test Face, Skin Piece and Text Stencils **M**
Clive Barker's Book Of Blood (2009)

A ghost mask, paint test face, a skin piece and stencils from the horror film adaptation of Clive Barker's Book of Blood. Hundreds of ghosts visited the haunted house and carved stories over Simon's (Jonas Armstrong) skin forming the Book of Blood. Barker hand-painted the mask during production, and a behind-the-scenes photo shows him holding this example. The lot comprises a full face latex mask with a decaying cracked paint finish and white tribal markings hand-painted by Barker himself and used on set, a vac-formed plastic paint test face, a latex prosthetic skin strip decorated with red-coloured text, and two metal text stencils. The mask comes on a display bust, and there is a small tear on the skin. Dimensions (mask): 24 cm x 22 cm x 37 cm (9 1/2" x 8 1/2" x 14 1/2")

Estimate. £800 - 1,200



802
Acsorius' (Jason Flemyng) Stunt Sword and Sheath **M**
Clash Of The Titans (2010)

Acsorius' (Jason Flemyng) stunt sword and sheath from Louis Leterrier's fantasy-adventure remake Clash of the Titans. Acsorius carried his sword during a flashback to Perseus' (Sam Worthington) childhood. The sword is made of rubber with a metal armature and is painted to resemble bronze. The sheath is made of leather and features a strap so it can be worn over the shoulder and rest on the hip. Both have been intentionally distressed to look old and well-used. Dimensions (sword): 72.5 cm x 6 cm x 7 cm (28 1/2" x 2 1/4" x 2 3/4")

Estimate. £2,000 - 3,000



804
Life-Size Posable Antarean Body **M**
Cocoon (1985)

A life-size posable Antarean body from Ron Howard's sci-fi comedy-drama Cocoon. Ancient aliens lived in cocoons kept in a rejuvenating pool to allow them to survive the trip home. This model is the "breathing" version, which features a rubber pipe at the base of its spine, through which air could be pumped. The hand-painted body is made of semi-rigid urethane with a jointed metal armature, which allows it to be curled into a foetal position. Sections of the body have been wrapped in light elasticated material. It is intentionally distressed, and the alien is missing several toes. Dimensions (laid flat): 175 cm x 48 cm x 21 cm (69" x 19" x 8 1/4") Special shipping required; see special shipping notice in the Buyer's Guide.

Estimate. £2,000 - 3,000



805
Hero Book, Knife, Union Flag,
Set of Letters, Photos and Chairbacks **M**
Cold Mountain (2003)

A collection of items from Anthony Minghella's period war epic Cold Mountain. The collection includes a knife with a wooden handle and leather scabbard; 34 empty envelopes addressed to William "W.P." Inman (Jude Law); handwritten letters from Ada Monroe (Nicole Kidman) to Inman; a rolled up hero book that is bound with a leather strap; a stamping kit; a costume continuity Polaroid photograph of Inman in bed; several black-and-white photographs of Inman and Monroe and hair samples; a Union Army regimental battle flag; and cloth chair backs for several cast and crew. Some items are purposely aged for effect, including water damage to the long letter from Monroe to Inman, and yellowing of the envelopes and letters. Dimensions: 51 cm x 51 cm x 23 cm (20" x 20" x 9")

Estimate. £2,000 - 3,000



807
John Bloomfield Hand-drawn Costume Design
for Conan (Arnold Schwarzenegger) and
Pit Fighter and Set of Concept Sketches **TD**
Conan The Barbarian (1982)

A hand-drawn John Bloomfield costume design for Conan (Arnold Schwarzenegger) and a pit fighter and concept sketches from the production of John Milius' fantasy adventure Conan the Barbarian. Signed by Bloomfield, the design shows Conan in mid-battle with a pit fighter. It is a collage formed of watercolour, pencil metallic ink and paper cuttings. Completing the set are eight additional sheets with sketches featuring Spanish annotations of costume components, some stapled with fabric samples. The lot displays pinholes and tears from production use. Dimensions (design): 38.5 cm x 52.5 cm (15 1/4" x 20 3/4") Sold without copyright; see copyright notice in the Buyer's Guide.

Estimate. £1,000 - 1,500



806
Cult of Set Amulet **TD**
Conan The Barbarian (1982)

A Cult of Set amulet from John Milius' fantasy film Conan the Barbarian. Members of the Cult of Set wore their amulets throughout the movie, as they followed their ruthless leader Thulsa Doom (James Earl Jones). The silver-painted metal amulet consists of two snakes looped around a sinister all-seeing eye with a curved horn situated at the top, and the emblem hangs on a length of black cord. It shows some minor tarnishing and fraying on the cord. Dimensions (cord extended): 48.5 cm x 9.5 cm x 2 cm (19" x 3 3/4" x 3/4")

Estimate. £2,000 - 3,000



808
John Bloomfield Hand-drawn Costume Design
for Subotai (Gerry Lopez) and Concept Sketches **TD**
Conan The Barbarian (1982)

A hand-drawn John Bloomfield costume design for Subotai (Gerry Lopez) and concept sketches from the production of John Milius' fantasy adventure Conan the Barbarian. The full-length design is signed by Bloomfield and was created using paper cuttings to form a collage, with pencil used to add detailing and a leather fabric sample stapled in one corner. Completing the lot are eight additional sheets with various sketches of different components of Subotai's attire annotated in Spanish. Some of the smaller sheets of paper display pinholes and small tears. Dimensions (largest design): 50 cm x 33 cm (19 3/4" x 13") Sold without copyright; see copyright notice in the Buyer's Guide.

Estimate. £1,000 - 1,500

809
John Bloomfield
Hand-drawn
Costume Design,
Concept Sketches
and Measurements
for Rexor
(Ben Davidson) †Δ
**Conan The
Barbarian (1982)**



A John Bloomfield costume design, concept sketches and measurements for Rexor (Ben Davidson) from the production of John Milius' fantasy adventure Conan the Barbarian. Signed by Bloomfield, the large sheet features a full-length collage design, three pencil sketches and an image of Davidson in costume. Completing the lot are two additional sheets with various boot designs and a measurements sheet dated "Oct 3 - 80". Dimensions (largest sheet): 50 cm x 37.5 cm (19 3/4" x 14 3/4") Sold without copyright; see copyright notice in the Buyer's Guide.

Estimate. £800 - 1,200



811
John Bloomfield Hand-painted Costume Designs
for Zula (Grace Jones), Princess Jehnna
(Olivia d'Abo) and Malak (Tracey Walter) †Δ
Conan The Destroyer (1984)

A set of three hand-painted John Bloomfield costume designs from the production of Richard Fleischer's fantasy-adventure sequel Conan The Destroyer. The lot consists of sketches for Zula (Grace Jones), Princess Jehnna (Olivia d'Abo) and Malak (Tracey Walter), all rendered in a mixture of watercolour and pencil on white paper and card. Each design is signed by Bloomfield and labelled with the film title, character name and actor name. There is evidence of erased pencil outlines and smudging from production use. Dimensions (design): 50.5 cm x 38 cm (20" x 15") Sold without copyright; see copyright notice in the Buyer's Guide.

Estimate. £800 - 1,200

810
John Bloomfield
Hand-painted
Costume Design
of Conan (Arnold
Schwarzenegger) †Δ
**Conan The
Destroyer (1984)**



A hand-painted John Bloomfield costume design of Conan (Arnold Schwarzenegger) from the production of Richard Fleischer's fantasy-adventure sequel Conan The Destroyer. The design is rendered in a mixture of watercolour and pencil on white paper and shows the warrior crouching whilst wielding a sword. It is signed by Bloomfield and is labelled "Madrid 1981" in the bottom right corner. There is evidence of erased pencil outlines, notably near the feet. Dimensions: 30 cm x 42 cm (11 3/4" x 16 1/2") Sold without copyright; see copyright notice in the Buyer's Guide.

Estimate. £1,000 - 1,500



812
Dr. Ellie Arrowway's (Jodie Foster)
Toy Compass with Prototype Compass and Chain †Ω
Contact (1997)

Dr. Ellie Arrowway's (Jodie Foster) toy compass with a prototype compass and chain from Robert Zemeckis' sci-fi film Contact. Palmer Joss (Matthew McConaughey) found a toy compass in his Cracker Jacks popcorn snacks and Arrowway wore it around her neck throughout the film, including on her fateful mission. This lot consists of a multicolour plastic compass with a thick brass-colour metal ring adhered to the top and "Made in China" engraved on the reverse; a matching prototype compass with a thin silver-colour ring; and a prototype brass-colour cable chain. Also included in the lot is a blue pin badge featuring the IMC logo. One of the compass needles has fallen off its bearing. Dimensions (each): 3.5 cm x 3 cm x 0.5 cm (1 1/2" x 1 1/4" x 1/4")

Estimate. £2,000 - 3,000



813
Coded Message Transparencies †Ω
Contact (1997)

A collection of coded message transparencies from Robert Zemeckis' sci-fi film Contact. Transparencies were used by Ellie Arrowway (Jodie Foster) and her team while decoding the extraterrestrial message that contained plans for an interstellar travel device. The collection consists of 49 transparencies and one paper document, all featuring the strange alien code, along with sticky notes and handwritten references. Dimensions (largest transparency): 48 cm x 48 cm (19" x 19")

Estimate. £800 - 1,200

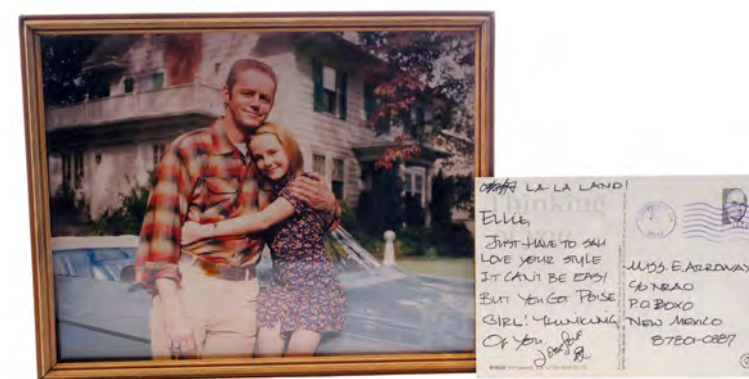

815
Dr. Ellie Arrowway's (Jodie Foster)
Postcard and Framed Family Photograph †Ω
Contact (1997)

Dr. Ellie Arrowway's (Jodie Foster) postcard and framed family photograph from Robert Zemeckis' sci-fi film Contact. Arrowway displayed photographs and a postcard sent by her now-deceased father (David Morse) in her rooms throughout the film. The postcard is black and white, and addressed to "Miss E. Arrowway", with a Cupertino, CA stamp on the reverse. The photograph has a wood-and-metal frame, and shows young Ellie (Jena Malone) with her father, in colour. The postcard's corners exhibit bending, and the backing on the frame has come loose following production. Dimensions (framed photo): 19.5 cm x 24.5 cm x 1.5 cm (7 3/4" x 9 3/4" x 1/2")

Estimate. £600 - 800

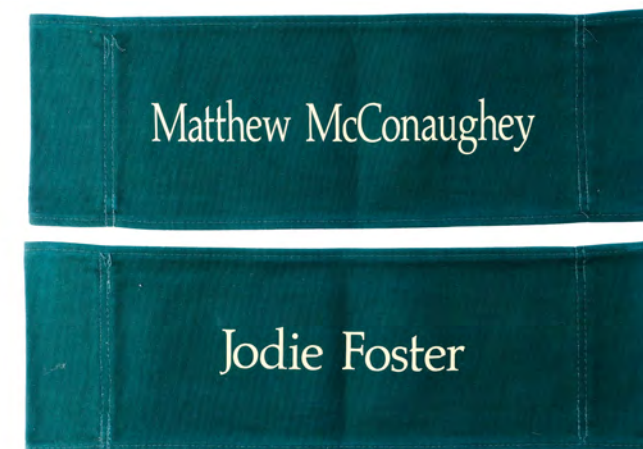

814
Jodie Foster and Matthew
McConaughey's Chair Backs †Ω
Contact (1997)

Jodie Foster and Matthew McConaughey's chairbacks from the production of Robert Zemeckis' sci-fi film Contact. Foster starred as Dr. Ellie Arrowway, a scientist studying extraterrestrial life; McConaughey co-starred as Christian philosopher Palmer Joss. Each of these canvas chairbacks features the production logo printed on one side and the actor's name on the other. Both exhibit fold lines from storage, fading to the logos and text, and minor stains from production use. Dimensions (each): 28 cm x 18 cm x 2.5 cm (11" x 7" x 1")

Estimate. £600 - 800



816
Dr. Ellie Arrowway's (Jodie Foster) Candidate
Profile, "The Machine" Data File and IMC Paperwork †Ω
Contact (1997)

Dr. Ellie Arrowway's (Jodie Foster) candidate profile, "The Machine" data file and IMC paperwork from Robert Zemeckis' sci-fi film Contact. Ellie's profile includes pages containing her personal, educational and medical history. "The Machine" file includes pages of data and graphs pertaining to the alien transportation device constructed in Cape Canaveral. The International Machine Consortium (IMC) paperwork includes six pages featuring an alien language, each with handwritten annotations and highlights; three pages of printed concept art of The Machine; and an empty IMC folder. Some of the paperwork has minor staining and the concept art has pin holes in each corner. Dimensions (candidate profile): 29.5 cm x 24 cm (11 1/2" x 9 1/2")

Estimate. £600 - 800



817
Hadden Industries ID Badges [Ω](#)
Contact (1997)

A collection of Hadden Industries ID badges from Robert Zemeckis' sci-fi film Contact. Employees and visitors at S. R. Hadden's (John Hurt) company wore ID badges as they worked on the second machine. The collection consist of laminated badges attached to plastic clips. 39 of the badges feature employee pictures and numbers, two feature photos on the wrong side of the badge, and two feature no photos at all. Also included with the lot are 10 plastic International Machine Consortium luggage label holders, nine plastic label ties, and two lanyards. Dimensions (each ID): 14 cm x 4.5 cm x 1 cm (5 1/2" x 1 3/4" x 1/4")

Estimate. £600 - 800



818
Dr. Ellie Arrowway (Jodie Foster) Pin
with IMC and Production Ephemera [Ω](#)
Contact (1997)

A Dr. Ellie Arrowway (Jodie Foster) pin with IMCn and production ephemera from Robert Zemeckis' sci-fi film Contact. Arrowway's supporters wore pins of her at the end of the film, while Members of the International Machine Consortium (IMC) carried blue memorabilia throughout, including at the Machine's launch. This lot consists of a black-and-white metal Arrowway pin; a blue cotton IMC hat; two metal IMC pins; and a blue and white vinyl IMC flag on a metal pole. Also included is a printed paper production logo. Dimensions (Arrowway pin): 5.5 cm x 5.5 cm (2 1/4" x 2 1/4")

Estimate. £500 - 700

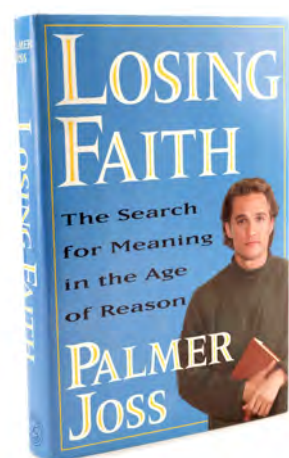

819
Palmer Joss' (Matthew McConaughey)
"Losing Faith" Book [Ω](#)
Contact (1997)

Palmer Joss' (Matthew McConaughey) "Losing Faith" book from Robert Zemeckis' sci-fi film Contact. Christian philosopher Palmer Joss promoted his book during a televised interview with Larry King. The hardback book features a picture of Joss on the cover and various testimonials on the back (misspelling "Joss" as "Loss"). The cover is wrapped around a copy of Deepak Chopra's Ageless Body, Timeless Mind. Dimensions: 24 cm x 16 cm x 3 cm (9 1/2" x 6 1/4" x 1 1/4")

Estimate. £400 - 600



820
Set of Four Hand-Drawn Ron Frenz
"Old Chief Wood'nhead" Comic Artworks [Ω](#)
Creepshow 2 (1987)

Four comic artworks hand-drawn by comic artist Ron Frenz for Michael Gornick's horror anthology sequel Creepshow 2. In the segment "Old Chief Wood'nhead," a cigar store Indian (Dan Kamin) came to life to avenge his murdered owner. Frenz created these four hand-pencilled and inked comic art pages at Anivision, LTD, for the segment. Each is rendered on DC Comics Bristol board, numbered, and labelled "Wood'nhead." Also included is a Certificate of Authenticity from animation supervisor Rick Catizone. The pages exhibit some graphite scrawling in the margins from production. Dimensions (each): 29.25 cm x 42 cm (11.5" x 16.5") Sold without copyright; see notice in the Buyer's Guide.

Estimate. £1,500 - 2,500



821
Set of Four Hand-Drawn Ron Frenz
"The Raft" Comic Artworks [Ω](#)
Creepshow 2 (1987)

Four comic artworks hand-drawn by comic artist Ron Frenz for Michael Gornick's horror anthology sequel Creepshow 2. In the segment "The Raft," a mysterious blob consumed four college students floating on a wooden raft. Frenz created these four hand-pencilled and inked comic art pages at Anivision, LTD, for the segment. Each is rendered on DC Comics Bristol board and two are labelled "The Raft." Also included is a Certificate of Authenticity from animation supervisor Rick Catizone. The pages exhibit some staining in the margins from production. Dimensions (each): 29.25 cm x 42 cm (11.5" x 16.5") Sold without copyright; see notice in the Buyer's Guide.

Estimate. £1,500 - 2,500



823
Production-used Clapperboard [M](#)
Crocodile Dundee (1986)

A clapperboard from the production of Peter Faiman's comedy Crocodile Dundee. The clapperboard features an acrylic slate, a wooden clapper and a plastic hinge. The slate features the film title and the names of director Faiman and cinematographer Russell Boyd, all engraved in black. Outlined boxes further divide the clapperboard into sections comprising slate, take, camera, sound, roll and date. Transparent adhesive tape is applied to the slate, upon which the roll number and the take number are handwritten in black marker pen. On the lower left of the slate is a drawing of a crocodile. On the rear of the clapperboard are the faded remnants of handwritten scene notes, the content of which suggests that the clapperboard was used in a scene filmed in the Australian Outback. Dimensions: 30.5 cm x 29 cm x 4 cm (12" x 11 1/2" x 1 1/2")

Estimate. £2,000 - 3,000



822
Set of Four Hand-Drawn Ron Frenz
"The Hitch-hiker" Comic Artworks [Ω](#)
Creepshow 2 (1987)

Four comic artworks hand-drawn by comic artist Ron Frenz for Michael Gornick's horror anthology sequel Creepshow 2. In the segment "The Hitch-hiker," a hitchhiker (Tom Wright) haunted the woman (Lois Chiles) who killed him. Frenz created these four hand-pencilled and inked comic art pages at Anivision, LTD, for the segment. Each is rendered on DC Comics Bristol board and two are labelled "The Hitch-hiker." Also included is a Certificate of Authenticity from animation supervisor Rick Catizone. They exhibit tape residue and additional notes handwritten in the margins from production. Dimensions (each): 29.25 cm x 42 cm (11.5" x 16.5") Sold without copyright; see notice in the Buyer's Guide.

Estimate. £1,500 - 2,500



824
Eric Draven's (Brandon Lee) Long-sleeved T-Shirt [M](#)
Crow, The (1994)

Eric Draven's (Brandon Lee) long-sleeved T-shirt from Alex Proyas' supernatural crime drama The Crow. Eric wore his T-shirt throughout the film. After returning from the grave, he donned his black attire as The Crow, hellbent on revenge. The T-shirt is custom-made from black Lycra with cotton cuff details. A piece of blue cotton fabric has been attached at the base of the waistband by the production to fasten between the legs to a piece of Velcro on the front of the T-shirt which was added to prevent the T-shirt from pulling up during acrobatic stunt work. It features the name "Eric" handwritten in black ink and shows minor fraying along the seams.

Estimate. £2,000 - 3,000



825
Printed Storyboard Binder [Ω](#)
Crow, The (1994)

A binder of printed storyboards from the production of Alex Proyas' action fantasy The Crow. Storyboards mapping out each frame in the film were rendered by the art department, then printed and distributed to various production teams. This blue vinyl, three-ring binder features a cover page labelled "The Crow" along with 338 printed, single-sided pages of black-and-white storyboards. Each storyboard features a scene and frame number, and several pages are affixed with yellow adhesive notes by production. Several pages exhibit minor tears from handling. Dimensions: 31.75 cm x 28 cm x 5 cm (12.5" x 11" x 2")

Estimate. £1,500 - 2,500



826
Set of 24 Printed Concept
Artworks with Handwritten Annotations [Ω](#)
Crow, The (1994)

24 printed concept artworks from the production of Alex Proyas' action fantasy The Crow. Concept art was created for various key sets, including Eric Draven's (Brandon Lee) apartment, Gideon's (Jon Polito) pawn shop, and the church where Sarah (Rochelle Davis) was held hostage, then distributed to key departments to help create Proyas' dark depiction of Detroit. This set of 24 printed artworks originated with production secretary Cindy J. Gray. Several are numbered and dated "1992," and others feature the printed signatures of their artists, including illustrators Peter Pound and Darren Gilford. They exhibit some staining, edge wear, and crease lines throughout. Dimensions (each): 42 cm x 30 cm (16.5" x 11.75")

Estimate. £400 - 600



827
Wanda Woodward's (Traci Lords) Leather Jacket [M](#)
Cry-Baby (1990)

Wanda Woodward's (Traci Lords) leather jacket from John Waters' romantic comedy musical Cry Baby. Wanda wore her leather jacket, which all the members of Cry-Baby's (Johnny Depp) gang of "drapes" donned, throughout the film. The black leather jacket features a front belt, epaulettes and "Cry Baby" handpainted in white across the back. It exhibits wear to the painted inscription, rust on the metal detailings and a small hole in the lining from production use and age.

Estimate. £2,000 - 3,000



828
Mystics SFX Enchantment Bowl [M](#)
Dark Crystal, The (1982)

A Mystic's SFX enchantment bowl from Jim Henson's fantasy film The Dark Crystal. On his deathbed, Mystic Master UrSu (Brian Muehl) used his enchantment bowl to reveal to the Gelfling Jen (performed by Jim Henson, Kathryn Mullen, Kiran Shah & voiced by Stephen Garlick) his destiny of "healing" the Dark Crystal by finding the lost shard. As UrSu reveals the prophecy, an illusion of the shard and the home of Ogra materialise out of the bowl. To create this illusion for the close up shots, the shard and Ogra's home were lowered into the liquid, which filled the bowl, and then played in reverse in post production. The Mystic's enchantment bowl is made of fibreglass, painted brown with a textured grain to imitate wood. It features spiral carvings around the exterior, three curved handles, three holes, and a thin spout protruding from the base. There are some glue remnants and areas of scuffing on the paintwork from production use and age. Dimensions: 45 cm x 45 cm x 29 cm (17 3/4" x 17 3/4" x 11 1/2")

Estimate. £2,000 - 3,000



829
SkekUng the Garthim Master's Production-Made
Armour and Costume Components [Ω](#)
Dark Crystal, The (1982)

SkekUng the Garthim Master's production-made armour and costume components from Jim Henson's and Frank Oz's fantasy adventure film The Dark Crystal. SkekUng wore his armoured costume commanding Garthim forces against the Gelflings. Made of fibreglass and resin, the set includes multi-colour plates; a talon and beak; a Skeksis head; simulated mechanical components and a faux orange crystal. Included is a photograph of SkekUng costume components. They exhibit wear, adhesive residue, and a missing talon. Dimensions (largest): 48.5 cm x 18 cm x 18 cm (19" x 7" x 7")

Estimate. £800 - 1,200



831
SkekTek the Scientist's Brooch
Prototype and Printed Concept Art [Ω](#)
Dark Crystal, The (1982)

SkekTek the scientist's brooch prototype and printed concept art from Jim Henson's and Frank Oz's fantasy adventure film The Dark Crystal. SkekTek, the scientist of the Skeksis, wore clothing adorned with technology and jewellery. This scorpion-shaped resin brooch is painted to resemble grey metal with a green patina, yellow talons in its claws and tail, and a centred orange faux crystal. Included is a printed copy of brooch concept sketches. The brooch exhibits minimal chipping; the print exhibits folding and edge wear. Dimensions (print, unfolded): 42 cm x 20.5 cm (16.5" x 12"); (brooch): 23 cm x 14 cm x 6.5 cm (9" x 5.5" x 2.5")

Estimate. £800 - 1,200



830
Chamberlain's (Frank Oz) Cloak Pin Prototype [Ω](#)
Dark Crystal, The (1982)

A prototype of Chamberlain's (Frank Oz) cloak pin from the production of Jim Henson's and Frank Oz's fantasy adventure The Dark Crystal. Chamberlain wore his cloak pin throughout the film as he schemed to become Emperor. Created by The Jim Henson Company, this moulded resin pin is hand-painted brown and yellow to resemble stone and bone. It features 10 faux bone spikes, seven faux rubies inset on the front, and an unfinished back for affixing to wardrobe. Several pieces are missing from the pin's top and bottom, and the resin exhibits white staining from exposure. Dimensions: 10.25 cm x 5.75 cm x 2.5 cm (4" x 2.25" x 1")

Estimate. £600 - 800



832
SkekUng the Garthim Master's Necklace Prototype [Ω](#)
Dark Crystal, The (1982)

SkekUng the Garthim Master's necklace prototype from Jim Henson's and Frank Oz's fantasy adventure The Dark Crystal. SkekUng, Garthim Master then Skeskis emperor, wore a large necklace. This mixed media necklace features fibreglass and yellow foam, painted grey with a beak-like centre element with yellow talons and a faux purple crystal, two attached bone-like pieces and two unattached bone-like pieces with talons. The fibreglass exhibits cracking and a broken piece of an unattached bone element. Dimensions (largest): 29.25 cm x 35.75 cm x 7.75 cm (11.5" x 14" x 3"); (smallest): 5.25 cm x 2.75 cm x 1.5 cm (2" x 1" x 0.5")

Estimate. £800 - 1,200



833
Skeksis Dagger Prototype Ω
Dark Crystal, The (1982)

A Skeksis dagger prototype from Jim Henson's and Frank Oz's fantasy adventure film *The Dark Crystal*. The Skeksis concealed daggers within their robes, including SkekZok (Jerry Nelson), who stabbed Kira (Kathryn Mullen). This resin dagger was originally created as a prototype for the stabbing scene, but is believed to have instead been used as a background piece on a Skeksis costume. It features a bone-like handle with a black faux stone, a silver-colour blade, and decorative patterns engraved throughout. The dagger exhibits scuffing, paint chipping, bending, and a large crack on the tip. Dimensions: 29.25 cm x 7 cm x 4.5 cm (11.5" x 2.75" x 1.75")

Estimate. £800 - 1,200



835
Set of Production and Promotional Photos and Ephemera Ω
Dark Crystal, The (1982)

A set of production and promotional photos and ephemera from Jim Henson's and Frank Oz's fantasy adventure film *The Dark Crystal*. This lot consists of several portfolios with production photographs and printed copies from various projects, including Skeksis concept sketches by Brian Froud; and photographs of printed dragon artwork; various photographs; one Christmas card from crew member Dave Barclay featuring Brian Froud artwork; and one press kit with the film's title logo containing cast and crew credits, press releases, and a copy of *Cinefantastique* Volume 13 Number 4. Some of the paper elements exhibit staining. Dimensions (largest): 45.75 cm x 33.25 cm x 1.5 cm (18" x 13" x 0.5"); (smallest): 8.25 cm x 8.25 cm (3.25" x 3.25")

Estimate. £1,500 - 2,500



834
SkekZok the Ritual Master's Decorative Brooch Prototype Ω
Dark Crystal, The (1982)

SkekZok the Ritual Master's decorative brooch prototype from Jim Henson's and Frank Oz's fantasy adventure film *The Dark Crystal*. SkekZok, the Ritual Master of the Skeksis, features several crescent moon motifs throughout his ensemble. This resin brooch is painted to resemble grey metal with a green patina, a textured scale-like finish, faux crystals, and yellow resin talons. It is mounted to a black wooden display base. It exhibits some light scratching to the brooch and base. Dimensions: 11.5 cm x 7.75 cm x 18 cm (4.5" x 3" x 7")

Estimate. £800 - 1,200



836
Steve Finch's (Matthew Broderick) Atomic War Lord Rocket Ω
Deck The Halls (2006)

Steve Finch's (Matthew Broderick) Atomic War Lord Rocket from John Whitesell's comedy film *Deck the Halls*. Steve bought the Atomic War Lord, a large, illegal rocket firework, to destroy Buddy Hall's (Danny DeVito) home after being driven to extremes. This lot consists of a yellow, warhead-shaped plastic rocket and a metal stand. From the collection of SPFX Coordinator Tony Lazarowich, this piece features a paper wrapping and painted yellow metal base. It exhibits scratches and creasing on the wrapping; scuffing and flaking on the paint; and scorch marks on the bottom. Dimensions (displayed): 35.75 cm x 21.75 cm x 21.75 cm (14" x 8.5" x 8.5")

Estimate. £800 - 1,200



837
Billy Costigan's (Leonardo DiCaprio) Hero Walther PPK M
Departed, The (2006)

Billy Costigan's (Leonardo DiCaprio) hero Walther PPK from Martin Scorsese's crime drama *The Departed*. Undercover cop Costigan carried his pistol throughout the film. Marked with the serial number "A084789", this pistol is a hero Interarms Walther PPK made of nickel-plated steel with black plastic grips. The weapon has been sympathetically deactivated and features an operable slide, magazine release, hammer and trigger. A threaded barrel allows for the attachment of a suppressor. The pistol is supplied with a certificate of deactivation and a copy of the original rental paperwork from the production armours. Dimensions: 15 cm x 2.5 cm x 11.5 cm (6" x 1" x 4 1/2") Firearm deactivated; see firearm deactivation notice in the Buyer's Guide.

Estimate. £2,000 - 3,000

838
Staff Sergeant Sean Dignam's (Mark Wahlberg) Stunt Pistol and Holster Ω
Departed, The (2006)



Sgt. Sean Dignam's (Mark Wahlberg) stunt pistol and holster from Martin Scorsese's crime drama *The Departed*. Dignam wore his pistol in his shoulder holster throughout the film. This moulded black foam rubber stunt SIG-Sauer P229 handgun features a "SIG SAUER" and "P229" stamp on either side. The weapon is hand-marked "MW" in silver-colour ink near the trigger. Also included is a self-fastening black nylon holster. The foam exhibits some pitting and cracking from production. Dimensions: 20.5 cm x 15.25 cm x 10.25 cm (8" x 6" x 4") Ownership may be restricted in some countries; see replica firearm notice in Buyer's Guide.

Estimate. £2,500 - 3,500

839
Colin Sullivan's (Matt Damon) Police Badge Set M
Departed, The (2006)



Colin Sullivan's (Matt Damon) police badge set from Martin Scorsese's Oscar-winning crime drama *The Departed*. While on duty, Sullivan wore his badge either around his neck or attached to his belt. The lot includes one metal badge and two leather holders. The badge reads "Mass State Police Sergeant" and is attached to a folded leather holder, which has a metal clip on the back and "MD" handwritten inside the leather. The second leather holder is circular and has a metal neck chain. Dimensions (badge and backing): 10 cm x 7 cm x 3 cm (4" x 2 3/4" x 1 1/4")

Estimate. £4,000 - 6,000



840
Colin Sullivan's (Matt Damon)
SIG Sauer Pistol and Holster M
Departed, The (2006)

Sullivan's (Matt Damon) SIG Sauer pistol and holster from Martin Scorsese's Oscar®-winning crime drama The Departed. Sullivan carried his weapon throughout the film and placed the gun and holster on a desk before "interrogating" Patrick "Fitzy" Fitzgibbons (David O'Hara). The weapon is a black plastic airsoft pistol with a moving slide, trigger, hammer and removable magazine clip. The black leather holster has "Sully" handwritten on the back in black marker. Dimensions: 19.5 cm x 3.5 cm x 13.5 cm (7 3/4" x 1 1/2" x 5 1/4") Restricted ownership; see replica firearm notice in the Buyer's Guide.

Estimate. £3,000 - 5,000



841
Colin Sullivan's (Matt Damon)
Hero Knife, Retractable
Knife and Stunt Knife M
Departed, The (2006)

Colin Sullivan's (Matt Damon) hero knife, retractable knife and stunt knife from Martin Scorsese's Oscar®-winning crime drama The Departed. Sullivan accidentally stabbed an innocent man while being followed by Billy Costigan (Leonardo DiCaprio). The hero knife has a steel blade and handle. The retractable knife has an aluminium blade on a spring and a resin handle, and the stunt knife is made of rubber. The stunt knife has some paint wear and minor cracking. Dimensions (each knife): 20 cm x 1.5 cm x 4 cm (8" x 1/2" x 1 1/2")

Estimate. £2,000 - 3,000



842
Colin Sullivan's (Matt Damon)
Hero Flip Phone M
Departed, The (2006)

Colin Sullivan's (Matt Damon) hero flip phone from Martin Scorsese's Oscar®-winning crime drama The Departed. Sullivan used his phone throughout the film and carried it clipped to his belt. The Sanyo phone is predominantly made of plastic and rubber, and has a removable battery on the back. It has some scuffing and a build-up of grime in some of the grooves. Dimensions (folded): 11 cm x 5 cm x 3 cm (4 1/4" x 2" x 1 1/4") Contains electronics; see electronics notice in the Buyer's Guide.

Estimate. £800 - 1,200



843
Exorcism Metal Chair M
Devils, The (1971)

An exorcism metal chair from Ken Russell's historical drama horror film The Devils. Father Pierre Barre (Michael Gothard), Baron De Laubardemont (Dudley Sutton) and Father Mignon (Murray Melvin) all sat on metal chairs during their interrogation and exorcism of Sister Jeanne (Vanessa Redgrave). They are also seen to be used by members of the court during Father Grandier's (Oliver Reed) trial. This steel chair is a minimalist design featuring a crescent-shaped frame and legs. There is some rusting of the metal apparent due to age. Dimensions: 45 cm x 63 cm x 89.5 cm (17 3/4" x 23 3/4" x 35 1/2")

Estimate. £600 - 800

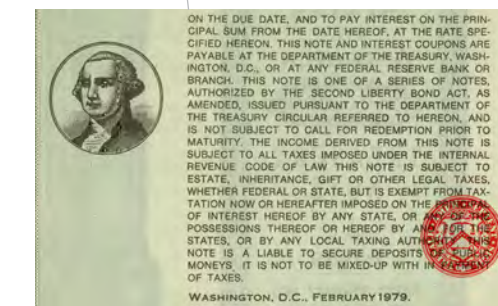

844
U.S. Treasury Note Ω
Die Hard (1988)

A U.S. Treasury note from John McTiernan's action thriller Die Hard. Professional thieves led by Hans Gruber (Alan Rickman) posed as terrorists to steal millions of dollars in bearer bonds from the vault in the Nakatomi building. Dated "February 1979," this light green, £100,000 bearer bond features mint green text, a red U.S. Treasury watermark stamp, and a red printing line down the front. There is a small printing imperfection next to the George Washington face, and the bottom of the note is truncated. It exhibits folded corners from production use. Dimensions: 38 cm x 24.25 cm (15" x 9.5")

Estimate. £2,000 - 3,000



845
John McClane's (Bruce Willis)
Bloodied Tank Top Ω
Die Hard With A Vengeance (1995)

John McClane's (Bruce Willis) bloodied tank top from John McTiernan's action-thriller sequel Die Hard With a Vengeance. McClane's tank top was progressively damaged and blood-stained as he and Zeus Carver (Samuel L. Jackson) attempted to stop terrorist Simon Gruber (Jeremy Irons) from robbing the Federal Reserve. This ribbed white cotton tank top is heavily distressed by production to appear blood-stained and covered in grime. Also included is a wardrobe tag hand-labelled "SC# 99-112." The top exhibits some stretching to the fabric from production wear.

Estimate. £3,000 - 5,000



846
John McClain's (Bruce Willis) Costume M
Live Free Or Die Hard (2007)

John McClane's (Bruce Willis) costume from Len Wiseman's action-thriller sequel Live Free or Die Hard. McClane wore his costume throughout the film, though it became more damaged and distressed as the action intensified. The small amount of intentional distressing and dark stains indicate the costume was made for the first half of the film, after the explosion in Matt Farrell's (Justin Long) apartment and up until McClane dove from the police car, which crashed into the helicopter. The costume consists of an army green long sleeve top, labelled size "M" with dark faux blood stains on the right sleeve, a cream tank top labelled size "M", and a pair of grey GAP trousers labelled size "32 x 32". Accompanying this lot is a certificate of authenticity from the Golden Closet.

Estimate. £3,000 - 5,000



848
Erudite Mutiny Stunt Assault Rifle and Pistol Ω
Divergent (2014)

An Erudite mutiny stunt assault rifle and pistol from Neil Burger's sci-fi adventure Divergent. The Erudite faction wielded rifles and pistols during the battle in which they brainwashed Dauntless members to help them overthrow Abnegation. These futuristic, custom-made, static resin and rubber stunt guns are both painted blue and black with matching copper-colour detailing and curved triggers inset to their bodies. Both exhibit paint chipping throughout, and the rifle's barrel is broken off from production use. Dimensions (rifle): 66.75 cm x 20.5 cm x 5 cm (26.25" x 8" x 2"); (pistol): 34.5 cm x 14 cm x 6.5 cm (13.5" x 5.5" x 2.5")

Estimate. £1,000 - 1,500

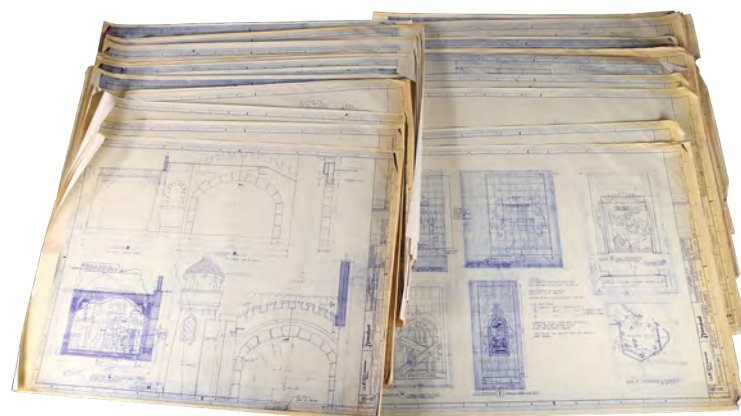

847
Set of 41 Blueprints for
Pinocchio's Daring Journey Ride M
Disneyland Theme Park (1983)

A collection of blueprints for the "Pinocchio's Daring Journey" theme-park attraction at Disneyland in Anaheim, California. The lot comprises 41 highly detailed blueprints featuring track layouts, murals and diagrams of various components, complete with extensive annotations and measurements. Each sheet has a title block containing several fields, including the project area (labelled "Fantasyland '83") and the unit name ("The Adventures of Pinocchio"). Presented in a rolled condition, the set exhibits several small tears, general wear and minor discolouration to the paper from age. Dimensions (largest): 92 cm x 122 cm (36 1/4" x 48")

Estimate. £800 - 1,200



849
Old Ben's Skull M
Django Unchained (2012)

Old Ben's skull from Quentin Tarantino's dramatic western Django Unchained. Candie (Leonardo DiCaprio) used the skull of an "old joe" named Ben that took care of him and his father to demonstrate his belief that black people were genetically subservient. The hollow skull has been cast in resin and hand-painted to imitate bone. It features a removable section at the back, which Caandie saws off during his speech to point out three dimples on the inside, and has since been glued in place. The skull exhibits a blue mark at the top front of the skull. Dimensions: 19 cm x 14 cm x 14 cm (7 1/2" x 5 1/2" x 5 1/2")

Estimate. £2,000 - 3,000



850
True Knot Steam Canister and Tags Ω
Doctor Sleep (2019)

A "steam" canister and tags from Mike Flanagan's horror sequel Doctor Sleep. The True Knot, a cult of psychics led by Rose the Hat (Rebecca Ferguson), collected "steam" in canisters by torturing and killing people who have the Shining, and used this essence to extend their lives. Rose breathed in steam to heal her wounds before the climactic fight against Danny (Ewan McGregor) and Abra (Kyliegh Curran). The canister is made of resin painted to look like metal. It is fixed in an "open" position, with the valves at the top extended outwards. It is accompanied by two fabric tags decorated with religious imagery, which were placed around the tops of the canisters by the cultists, and represented trophies from their victims. The canister has minor scratches and the tags are slightly faded. Dimensions: 10 cm x 10 cm x 21 cm (4" x 4" x 8 1/4")

Estimate. £3,000 - 5,000



851
Danny Torrance's (Ewan McGregor)
Screen-matched Jacket M
Doctor Sleep (2019)

Danny Torrance's (Ewan McGregor) screen-matched jacket from Mike Flanagan's horror sequel Doctor Sleep. Danny wore his work jacket for much of the film, including the climax at the Overlook Hotel, and the stitching in the lining matches the jacket worn as Danny speaks to Abra (Kyliegh Curran) in the park. The jacket zips up the front and has "M" handwritten in the collar. It is accompanied by a production tag reading "Distressed".

Estimate. £1,000 - 1,500



852
BBC Exhibition Battle-damaged Cyberman
Doctor Who: The Five Doctors (1983)

A battle-damaged Cyberman from The Five Doctors, a feature-length episode of the classic sci-fi TV series Doctor Who. Five of the incarnations of the Doctor were collected by an unknown being and deposited in the Death Zone on Gallifrey, along with Daleks, Cybermen and other enemies of the Doctor. Cybermen were attacked by the Raston Warrior Robot and killed. This Cyberman appeared in the Doctor Who exhibition in Longleat House. The Cyberman features a huge hole in the chest, filled with wires, bulbs, tubes, mesh and other items, as well as green "goo" made from painted hard foam. Long electrical wires protrude from the back of the costume. The suit and gloves are originals from the production and the helmet and boots are reproductions made by the BBC for the exhibition. The Cyberman has been intentionally distressed, but also has wear from age, including chips to the helmet and the silver paint flaking off the suit. The costume is on a mannequin. Dimensions (on mannequin): 42 cm x 62 cm x 197 cm (16 1/2" x 24 1/2" x 77 1/2") Special shipping required; see special shipping notice in the Buyer's Guide. Contains electronics; see electronics notice in the Buyer's Guide.

Estimate. £3,000 - 5,000



853
The Doctor's (Sylvester McCoy) TARDIS Key and Eric Roberts' Chairback
Doctor Who: The Movie (1996)

The Doctor's (Sylvester McCoy) TARDIS key and Eric Roberts' chairback from Geoffrey Sax's sci-fi television film Doctor Who: The Movie. While facing off against The Master (Eric Roberts), the Doctor used his key to lock the TARDIS before he was shot and rushed to the hospital. This lot consists of a silver-colour metal key on a chain embossed with geometric shapes, as well as a blue canvas chairback emblazoned "Eric Roberts." They key exhibits some discolouration from production and age. Dimensions (key): 37 cm x 3.25 cm x 0.75 cm (14.5" x 1.25" x 0.25"); (chairback): 58 cm x 18 cm (22.75" x 7")

Estimate. £2,000 - 3,000



854
Four Alien Heads
Including One Pan-Babylonian
Doctor Who: "The Rings Of Akhaten" (T.V. Series, 2013)

Four alien heads, including one Pan-Babylonian, from the BBC sci-fi series Doctor Who. In the Season 7 episode "The Rings of Akhaten" the Doctor (Matt Smith) and Clara (Jenna Coleman) visited a teeming alien market on the asteroid of Tiaanamat. This foam latex collection includes a Pan-Babylonian mask, a tentacle species mask with a rubber gas mask, a gilled mask and an eyeless head with a tentacle hanging from the corners of its mouth. Each featured a strip of Velcro®, as well as rips and minor cracking from production use. Dimensions (largest head): 32 cm x 36 cm x 42 cm (12 1/2" x 14 1/4" x 16 1/2")

Estimate. £1,500 - 2,500

855
Pan Babylonian and Three Background Creature Heads
Doctor Who: "The Rings Of Akhaten" (T.V. Series, 2013)

A Pan Babylonian and three background creature heads from the Season 7 episode The Rings of Akhaten of the revived BBC sci-fi series Doctor Who. The Doctor (Matt Smith) and Clara (Jenna Coleman) visited a teeming alien market and witnessed the Festival of Offerings on the asteroid Tiaanamat. Pan Babylonians were one of the species identified by the Doctor. The green-coloured Pan Babylonian mask features a patterned fin, pointed ears and a pair of glossy brown eyes. Completing the lot is a wrinkled, brown-patterned foam-latex mask; a beige-and-brown foam latex mask with detailed teeth; and a green latex mask with an elaborate breathing apparatus. The lot displays small rips and cracking, and the front of the breathing apparatus is loose. Dimensions (largest head): 62 cm x 28 cm x 25 cm (24 1/4" x 11" x 9 3/4")

Estimate. £1,500 - 2,500

856
Lugal-Irra-Kush, Eukanian, Lucanian & One Other Alien Head
Doctor Who: "The Rings Of Akhaten" (T.V. Series, 2013)

A Lugal-Irra-Kush, a Eukanian, a Lucanian and one other alien head from the BBC sci-fi series Doctor Who. In the Season 7 episode "The Rings of Akhaten", the Doctor (Matt Smith) and Clara (Jenna Coleman) visited a teeming alien market on the asteroid of Tiaanamat. This foam latex collection includes a horned Lugal-Irra-Kush mask, a finned Eukanian mask, a Lucanian mask with a bulbous skull and a helmet with a clear acrylic dome containing a set of battery-powered LEDs. Each item features strips of Velcro®, rips, and cracking from production use. Dimensions (Lugal-Irra-Kush head): 46 cm x 32 cm x 33 cm (18" x 12 1/2" x 13") Contains electronics; see electronics notice in the Buyer's Guide.

Estimate. £1,500 - 2,500

IN AID OF
BBC
CHILDREN
IN NEED

Lots 858 - 873 are being auctioned to raise funds for BBC Children In Need, a British charity committed to positively changing the lives of children and young people across the UK and on their behalf. All assets have been donated by BBC/BBC Studios Productions Limited direct from the show. A percentage of the final hammer price of these Auction Items will benefit BBC Children in Need (charity number 802052 in England & Wales and SC039557 in Scotland.) BBC Children in Need, Pudsey Bear and Blush are trade marks of the BBC and are used under licence. Additional lots from the collection can be found on Day 1 of the auction.

857
 BBC Children in Need Collection: Full-Size New Paradigm Drone Dalek Skirt +
Doctor Who (T.V. Series, 2005-Present)

A New Paradigm Drone Dalek skirt from the production of BBC sci-fi series Doctor Who. The New Paradigm were first introduced in the Season 5 episode "Victory of the Daleks". These new Daleks were much bulkier than their predecessors and introduced a colour-coded hierarchy. The bright red Drone Dalek also appeared in the Season 5 episode "The Pandorica Opens" and Season 7's "Asylum of the Daleks", where its red casing colour was much darker, as with this particular Dalek. The Dalek's skirt is made of moulded fibreglass and resin with a medium-density fibreboard interior, all fitted onto a black rubber base. It features grey sense globes, and a wooden operator seat is fitted inside. The lot exhibits notable paint wear and several of the sense globes are missing. However, the skirt exhibits some sympathetic restoration and assembly. Dimensions: 136 cm x 95 cm x 138 cm (53 1/2" x 37 1/2" x 54 1/4") Special shipping required: see special shipping notice in the Buyer's Guide.

Estimate. £1,000 - 1,500



858
 BBC Children in Need Collection:
 Two Full-Size Melted Dalek Skirts +
Doctor Who (T.V. Series, 2005-Present)

Two melted Dalek skirts from the BBC sci-fi series Doctor Who. In the Season 7 premiere "Asylum of the Daleks", Rory (Arthur Darvill) discovered a room full of heavily damaged and melted Daleks, after The Doctor (Matt Smith) hacked an idle Dalek with his sonic screwdriver and caused it to self-destruct. Each Dalek skirt is made of fibreglass, resin, medium-density fibreboard and expanding foam, textured and painted to look like melted metal and plastic. The lot displays significant paint wear, missing bosses and damage from its time spent in previous storage facilities. Dimensions (largest): 145 cm x 97 cm x 140 cm (57" x 38 1/4" x 55 1/4") Special shipping required: see special shipping notice in the Buyer's Guide.

Estimate. £1,000 - 1,500



859
 BBC Children in Need Collection:
 Full-Size Melted Dalek +
Doctor Who (T.V. Series, 2005-Present)

A melted Dalek from the BBC sci-fi series Doctor Who. Destroyed Daleks were seen in the Series 7 premiere "Asylum of the Daleks". While being chased by a horde of Daleks, The Doctor (Matt Smith) used his sonic screwdriver to hack an idle Dalek and send it careening backwards into his pursuers, causing a massive explosion that left melted Daleks in its wake. The melted Dalek is made of fibreglass, resin, medium-density fibreboard and expanding foam. It is textured and painted to look like melted metal and plastic. The Dalek shows paint wear and damage from its time spent in previous storage facilities. Dimensions: 95 cm x 110 cm x 100 cm (38" x 43" x 39") Special shipping required: see special shipping notice in the Buyer's Guide.

Estimate. £1,000 - 1,500

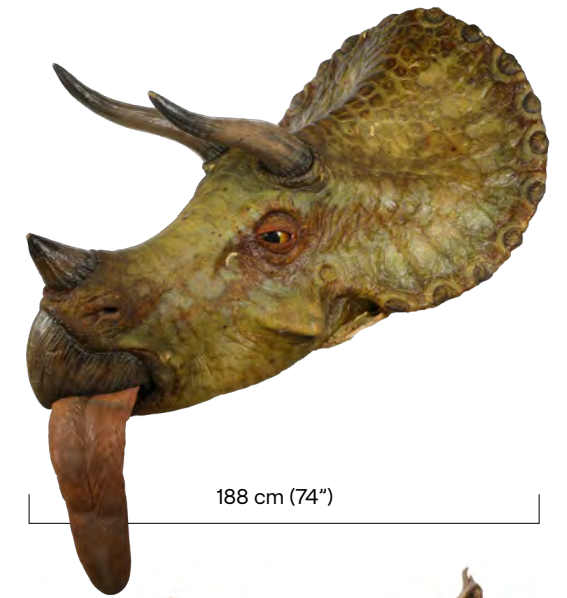

188 cm (74")

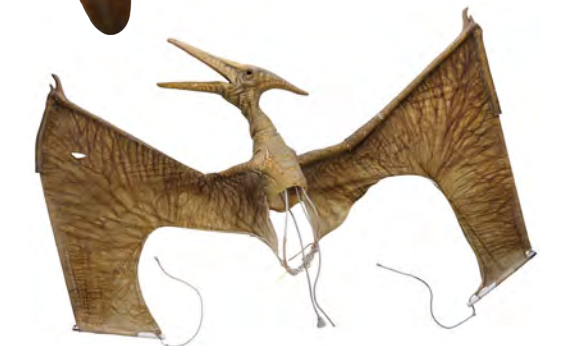

238 cm (93.75")

860
 BBC Children in Need Collection:
 Full-size Triceratops
 Head and SFX Pterodactyl +
**Doctor Who: "Dinosaurs On A
 Spaceship" (T.V. Series, 2012)**

A triceratops head and SFX pterodactyl from BBC sci-fi TV series Doctor Who. In the episode "Dinosaurs on a Spaceship", The Doctor (Matt Smith) rode a triceratops and was attacked by pterodactyls. The triceratops head comprises a fibreglass shell with foam-latex skin and features a foam tongue. The pterodactyl consists of a foam-latex head and torso with stretch-fabric wings. One wing has a small tear, and the foam-latex exhibits minor wear. Dimensions (triceratops): 188 cm x 105 cm x 80 cm (74" x 41 1/4" x 31 1/2") Contains electronics; see electronics notice in the Buyer's Guide. Special shipping required: see special shipping notice in the Buyer's Guide.

Estimate. £1,000 - 1,500



861
BBC Children in Need Collection:
Set of Creature Faces
and Slitheen Head +
Doctor Who

A set of creature faces and a Slitheen head from the BBC sci-fi series Doctor Who. The Doctor fought and befriended many monsters and aliens throughout the series. This lot consists of 13 latex faces from various episodes. Eight of these represent the infected crew members from the 2009 Autumn Special episode "The Waters of Mars", and there is also the blue latex face of Madame Vastra, a recurring character and ally of The Doctor. Also included is a Slitheen head made of latex applied to mesh wrapped around a resin shell, with metal mechanisms linked to wiring that feeds into the interior. This head exhibits wear from production use, including patches of mesh revealed by peeling latex and cracks to the interior shell. The mechanisms have not been tested. Dimensions (Slitheen head): 51 cm x 30 cm x 27 cm (20" x 11 3/4" x 10 3/4") A percentage of the final hammer price of this Auction Item will benefit BBC Children in Need (charity number 802052 in England & Wales and SC039557 in Scotland). Contains electronics; see electronics notice in the Buyer's Guide. Contains mechanical components; see mechanical notice in the Buyer's Guide.

Estimate. £1,000 - 1,500



862
BBC Children in Need Collection:
Modern Cyberman Pieces +
Doctor Who: Nightmare In Silver
(T.V. Series, 2013)

An assortment of Cyberman pieces from the BBC sci-fi series Doctor Who. These pieces are from the latest redesign of the Cybermen, first seen in the Series 7 episode "Nightmare in Silver". This lot comprises a fibreglass chest piece attached to wooden beams (with a circular metal panel that opens and closes via a lever on the inside) and a selection of silver-painted foam latex, Lycra and rubber body pieces. The cowl is labelled "2013 Cyber Collar" and "Aidan", and the rubber forearm "2013 Cyber Forearm". Circular domes on the wrist attachments light up in green and red. The lot exhibits significant wear, including cut-away sections, tears and foam disintegration, and scuffs and scratches. Dimensions (chest piece): 50 cm x 47.5 cm x 42.5 cm (19 3/4" x 18 3/4" x 16 3/4") A percentage of the final hammer price of this Auction Item will benefit BBC Children in Need (charity number 802052 in England & Wales and SC039557 in Scotland). Contains electronics; see electronics notice in the Buyer's Guide.

Estimate. £800 - 1,200



863
BBC Children in Need Collection:
Cyberman Pieces +
Doctor Who: Rise Of The
Cybermen (T.V. Series, 2006)

An assortment of Cyberman pieces from the BBC sci-fi series Doctor Who. These pieces are from the Cybus Cybermen redesign, first seen in the series 2 episode "Rise of the Cybermen". This lot comprises one silver-painted foam body piece; a Lycra-and-foam cowl (labelled "Karl"); a pair of fibreglass legs; one fibreglass arm ("Kasey"); and a pair of feet. One foot comprises a fibreglass shell covering a size 44 boot. The other is made from rubber with a separate foam-rubber sole. The set exhibits significant wear, including paint wear, foam disintegration, missing pieces, and tears in the rubber. Dimensions (body piece): 85 cm x 49 cm x 22.5 cm (33 1/2" x 19 1/4" x 9") A percentage of the final hammer price of this Auction Item will benefit BBC Children in Need (charity number 802052 in England & Wales and SC039557 in Scotland).

Estimate. £800 - 1,200



864
BBC Children
in Need Collection:
Cyberman Pieces +
Doctor Who: Rise Of
The Cybermen (T.V.
Series, 2006)

An assortment of Cyberman pieces from the BBC sci-fi series Doctor Who. These pieces are from the Cybus Cybermen redesign, first seen in the Series 2 episode "Rise of the Cybermen". This lot comprises a foam and fibreglass body piece; a black lycra and foam cowl; fibreglass legs; four rubber arms; and a pair of rubber and foam latex feet. Each piece is painted silver and intentionally distressed. The lot also exhibits wear, including a tear in the cowl. Dimensions (one leg): 95 cm x 22.5 cm x 20.5 cm (37 1/2" x 8 3/4" x 8") A percentage of the final hammer price of this Auction Item will benefit BBC Children in Need (charity number 802052 in England & Wales and SC039557 in Scotland).

Estimate. £800 - 1,200

866
BBC Children
in Need Collection:
Stone Cyberman +
Doctor Who:
The Big Bang

A stone Cyberman from BBC sci-fi series Doctor Who. Stone enemies of the Doctor (Matt Smith) were seen in Season 5 episode "The Big Bang", as ominous cracks in time spread across the universe, temporarily causing the Doctor's enemies to be erased, leaving only their petrified afterimages. The Cyberman is made from resin and rubber pieces placed on a plastic mannequin. It is covered in a thin layer of cement to lock the limbs in place and give it a stone-like appearance. The legs are detachable. Dimensions: 165 cm x 80 cm x 40 cm (65" x 31 1/2" x 16") Special shipping required: see special shipping notice in the Buyer's Guide.

Estimate. £800 - 1,200



865
BBC Children
in Need Collection:
Cyberman Pieces +
Doctor Who: Rise Of
The Cybermen (T.V.
Series, 2006)

An assortment of Cyberman pieces from the BBC sci-fi series Doctor Who. These pieces are from the Cybus Cybermen redesign, first seen in the Series 2 episode "Rise of the Cybermen". Painted in silver, this lot comprises a foam body piece; two resin right-leg calf pieces; one resin left-leg calf piece; a foam-latex helmet back; and a pair of resin and rubber-latex feet encasing a pair of unsized boots. The lot exhibits some production wear. Dimensions (body piece): 93 cm x 75 cm x 24 cm (36 3/4" x 29 1/2" x 9 1/2") A percentage of the final hammer price of this Auction Item will benefit BBC Children in Need (charity number 802052 in England & Wales and SC039557 in Scotland).

Estimate. £800 - 1,200

867
BBC Children in Need
Collection: Auton
SFX Head and Set of
Blaster Hands +
**Doctor Who: Rose/
The Pandorica Opens/
The Big Bang**

An Auton SFX head and a set of Auton blaster hands from the BBC sci-fi series Doctor Who. In the Season 1 premiere "Rose", the Autons were disguised as mannequins. This lot comprises two hinged fibreglass hands and a foam-rubber head mounted on a metal frame that swivels at the neck. Also included is another fibreglass hand, fastened to a pole, from the Season 5 episode "The Pandorica Opens". Painted to resemble skin, the hand has a split with two metal gun barrels. Dimensions (head): 64 cm x 35 cm x 21 cm (25 1/2" x 13 3/4" x 8 1/2") A percentage of the final hammer price of this auction Item will benefit BBC Children in Need (charity number 802052 in England & Wales and SC039557 in Scotland).

Estimate. £800 - 1,200





868
BBC Children in Need Collection:
Cherub Weeping Angel Heads and Hands,
and Pair of Weeping Angel Arms +
Doctor Who: The Angels Take Manhattan

An assortment of cherub Weeping Angel heads and hands, and a pair of Weeping Angel arms from the BBC sci-fi series Doctor Who. The Weeping Angels featured in the Season 7 episode "The Angels Take Manhattan". This lot consists of two cherub heads, three cherub arms, nine cherub hands and a pair of Weeping Angel arms. Each piece is made of resin painted to resemble stone and features a metal rod protruding from its base. Some items exhibit production wear including missing fingers. Dimensions (largest Weeping Angel arm): 65 cm x 21 cm x 13.5 cm (25 1/2" x 8 1/4" x 5 1/4") A percentage of the final hammer price of this Auction Item will benefit BBC Children in Need (charity number 802052 in England & Wales and SC039557 in Scotland).

Estimate. £800 - 1,200



870
BBC Children in Need Collection: Abzorbaloff
(Peter Kay) SFX Close-Up Belly and Back Prosthetics +
Doctor Who: Love And Monsters

Abzorbaloff's (Peter Kay) SFX close-up belly and back prosthetics from the BBC sci-fi series Doctor Who. In the episode "Love and Monsters", several people were absorbed by Abzorbaloff and their faces appeared on his belly. Made of foam latex, the lot comprises a back piece and three belly pieces. The back piece has faux hair down its spine, and two of the belly pieces are fastened to resin shells across a metal frame. Each belly piece has a hole for actors to insert their faces. Dimensions (largest piece): 77 cm x 116 cm x 38 cm (30 1/4" x 45 1/4" x 15") A percentage of the final hammer price of this auction item will benefit BBC Children in Need (charity number 802052 in England & Wales and SC039557 in Scotland).

Estimate. £600 - 800



869
BBC Children in Need Collection:
Aristotle Gun and Grappling Launcher +
Doctor Who: Into The Dalek

An Aristotle gun and grappling launcher from BBC sci-fi series Doctor Who. In the Season 8 episode "Into the Dalek", soldiers carried weapons on the rebel human ship Aristotle. This lot includes a red rifle with a long red silencer and a grappling launcher. The rifle is made predominantly of resin and is painted red and silver. It features a metal-and-resin stock, with wire protruding from its top. The rifle no longer has the trigger and grip section underneath. The grapple launcher is made from a metal pipe with resin detailing. It has a sticker on the side which reads "Aristotle - Dual Grappling Launcher", a black strap, and a static switch. Both pieces have been intentionally distressed, and the grappling launcher has some chips and a resin section that's broken near one end. Dimensions (rifle): 84 cm x 6 cm x 18 cm (33" x 2 1/4" x 7")

Estimate. £600 - 800



871
BBC Children in Need Collection:
Brian Williams (Mark Williams) Costume +
Doctor Who: Dinosaurs On A Spaceship (2012)

Brian Williams' (Mark Williams) costume from the Season 7 episode Dinosaurs on a Spaceship of the revived BBC sci-fi series Doctor Who. Brian found himself, alongside his son Rory (Arthur Darvill) and daughter-in-law Amy (Karen Gillan), in an adventure with The Doctor (Matt Smith), exploring an uncrewed ship containing several prehistoric dinosaurs. The costume comprises two pairs of navy cargo trousers (size men's 36), a pair of brown M&S trainers, and a white T-shirt decorated with a multi-coloured geometric design unseen in the final cut of the episode. The costume comes with a production costume label. A percentage of the proceeds from the sale of this lot will be donated to

Estimate. £400 - 600



872
BBC Children in Need Collection:
Mr. Brock's (Adetomiwa Edun) Prosthetic Head +
Doctor Who: The Return Of Doctor Mysterio

Mr Brock's (Adetomiwa Edun) prosthetic head from the BBC sci-fi series Doctor Who. In the Season 10 Christmas special episode "The Return of Doctor Mysterio", Mr Brock's body was taken over by brain-swapping aliens attempting to colonise earth. When confronted by The Doctor (Peter Capaldi), Brock opened his head and pulled out a gun that was concealed there. This latex prosthetic head is made in the likeness of actor Edun. It features resin eyes and synthetic eyelashes, eyebrows and hair. The head hinges open via a diagonal split, revealing the alien's solid blue goo-like structure inside. Dimensions: 27 cm x 36 cm x 40 cm (10 3/4" x 14 1/4" x 15 3/4") A percentage of the final hammer price of this Auction Item will benefit BBC Children in Need (charity number 802052 in England & Wales and SC039557 in Scotland).

Estimate. £400 - 600



874
Four Lobby Cards with Jack D.
Ripper (Sterling Hayden) Still +
**Dr. Strangelove Or: How I Learned
To Stop Worrying And Love The Bomb (1964)**

Four lobby cards with a still of Jack D. Ripper (Sterling Hayden) from Stanley Kubrick's classic war satire Dr. Strangelove or: How I Learned to Stop Worrying and Love the Bomb. Columbia Pictures distributed lobby cards highlighting star Peter Sellers' many characters to promote the film. This lot consists of four original colour-printed lobby cards dated "1963 Columbia Pictures" and featuring Dr. Strangelove (Sellers), the iconic War Room and military base sets, and Ripper with Lionel Mandrake (Sellers). Also included is a black-and-white glossy still of Ripper with his signature cigar. The cards exhibit some tape residue, pinholes, and discolouration from age. Dimensions (each): 35.75 cm x 28 cm (14" x 11")

Estimate. £200 - 300

873
No Lot



875
Vermithrax Pejorative Scale +
Dragonslayer (1981)

A dragon scale from Matthew Robbins' adventure fantasy Dragonslayer. Scales were shed by the vicious dragon Vermithrax Pejorative, who terrorised the kingdom of Urlund. Scales were gathered by Valerian (Caitlin Clarke) and affixed to Galen's (Peter MacNicol) shield to protect him against Vermithrax's flame breath. The scale is made of fibreglass and resin, with a raised centre and a textured ripple effect towards one end. It is painted dark grey-brown and portions of silicon with imprints of other scales remain on the both sides, suggesting it may have formed part of the dragon-scale shield. The scale shows signs of paint wear and degradation to the resin from age. Dimensions: 33 cm x 20 cm x 3 cm (13" x 8" x 1")

Estimate. £600 - 800



876
Framed Hand-Painted
Ron Miller Harkonnen
Flagship Concept Artwork Ω
Dune (1984)

Framed Harkonnen flagship concept artwork hand-painted by illustrator Ron Miller for the production of David Lynch's sci-fi epic Dune. The Harkonnens travelled on massive flagships to Arrakis along with the Sardaukar. This artwork depicting front, back, and bird's-eye views of a flagship is rendered in mixed media on bordered drawing paper and labelled "Harkonnen Flagship 1X Drop Forge and Tool Works." It comes behind glass in a black matte board and wood frame. The artwork is applied with correction fluid and exhibits some liquid staining. Dimensions (framed): 91.5 cm x 48.25 cm x 5 cm (36" x 19" x 2") Sold without copyright; see notice in the Buyer's Guide.

Estimate. £2,000 - 3,000



877
Framed Hand-Painted Ron Miller
Ornithopter Concept Artwork Ω
Dune (1984)

Framed Ornithopter concept artwork hand-painted by illustrator Ron Miller for the production of David Lynch's sci-fi epic Dune. Ornithopters, weapons-equipped transport vessels, were the standard aircraft of the Imperium. This artwork depicting an Ornithopter's front and back angles is rendered in mixed media on bordered drawing paper, labelled "Ornithopter 3-Passenger Fighter 1X Drop Forge and Tool Works," and signed by Miller. It comes behind glass in a black matte board and wood frame. The lot exhibits smudging, staining, and scratching to the glass from handling. Dimensions (framed): 96.5 cm x 53.5 cm x 5 cm (38" x 21" x 2") Sold without copyright; see notice in the Buyer's Guide.

Estimate. £2,000 - 3,000



878
Framed Hand-Painted Ron Miller
Sandworm Concept Artwork Ω
Dune (1984)

Framed sandworm concept artwork hand-painted by illustrator Ron Miller for the production of David Lynch's sci-fi epic Dune. Massive sandworms threatened to destroy Arrakeen, the main city of Arrakis. This artwork featuring nine various angles for the sandworms is rendered in mixed media on bordered drawing paper, labelled "The Arrakeen Sandworm," "Dr. Liet Kynes, I.E.," and "Gas Sphincters," and signed by Miller. It comes behind glass in a black matte board and wood frame. The artwork exhibits stains and smudges in its upper margins. Dimensions (framed): 81.5 cm x 53.5 cm x 5 cm (32" x 21" x 2") Sold without copyright; see notice in the Buyer's Guide.

Estimate. £2,000 - 3,000



879
Hero Exosuit Arm
and Stunt Weapon M
Edge Of Tomorrow (2014)

A hero exosuit arm and stunt weapon from Doug Liman's graphic novel adaptation Edge of Tomorrow. Exosuits were worn by Cage (Tom Cruise), Rita (Emily Blunt) and the UDF military against the race of strange alien creatures that invaded Earth. The exosuit arm is made from resin painted dark green with a plastic and rubber grip featuring functioning buttons, an arm support with foam protection and a Velcro® strap, a claw attachment at the front locked in place and a resin screen above the handle. Attached to the arm is a stunt machine gun made from resin painted black with a rubber tube affixed to the back to look like a cable, and features a UDF label with a barcode and the organisation's emblem. Dimensions: 66 cm x 28 cm x 25 cm (26" x 11" x 10") Restricted ownership; see replica firearm notice in the Buyer's Guide.

Estimate. £3,000 - 5,000



880
Cage's (Tom Cruise) Shotgun M
Edge Of Tomorrow (2014)

Cage's (Tom Cruise) shotgun from Doug Liman's sci-fi action film Edge of Tomorrow. Cage was given his shotgun by Rita (Emily Blunt) after the pair crash-landed their drop ship into the Louvre, and subsequently used the weapon to kill the alien "Mimics". The shotgun is cast from a Benelli Supernova and is made of hardened rubber and a metal armature. The shotgun has some rusty discolouration, staining and water damage distressing from production, as the Louvre set was very dirty and wet, with Cage running through water while carrying the weapon. Dimensions: 65 cm x 5 cm x 19 cm (25 1/2" x 2" x 7 1/2") Restricted ownership; see replica firearm notice in the Buyer's Guide.

Estimate. £2,000 - 3,000



881
Major William Cage's (Tom Cruise)
Stunt Claymore M
Edge Of Tomorrow (2014)

Major William Cage's (Tom Cruise) stunt claymore from Doug Liman's sci-fi action film Edge of Tomorrow. Cage used an anti-personnel mine to destroy the large Mimic on the French beach, and was subsequently covered in the creature's blood, causing him to relive the same day repeatedly. The claymore is made predominantly of rubber, with resin handles, and it is painted in different shades of green. Claymores do not usually have handles; these were added specifically for the film. "Front Toward Enemy" is featured in raised lettering on the front, where there is also some paint wear. Dimensions: 7 cm x 27 cm x 18.5 cm (2 3/4" x 10 1/2" x 7 1/4")

Estimate. £1,000 - 1,500



882
UDF Exo-Suit Rifle †Δ
Edge Of Tomorrow (2014)

A UDF exo-suit rifle from Doug Liman's sci-fi action film Edge of Tomorrow. United Defense Force soldiers wore large mechanical exo-suits with rifles mounted on their forearms. The rifle is made of biscuit foam with a resin shell and a metal barrel. A UDF barcode is adhered along the right side, and the back of the rifle has a hinged section, which attached it to the suit. The resin shell has chipped in a few places. Dimensions: 62 cm x 8 cm x 24 cm (24 1/2" x 3 1/4" x 9 1/2") Restricted ownership; see replica firearm notice in the Buyer's Guide.

Estimate. £1,000 - 1,500

883
Annotated Storyboard Binder, FX File, and Books Ω
Elf (2003)

An annotated storyboard binder, an FX file, and books from Jon Favreau's holiday movie Elf. From the collection of SPFX Coordinator Tony Lazarowich, this lot consists of one binder, a bound file, and two books. The binder, dated for 2002-2003, features 360 pages of photocopied storyboards and production paperwork with notes and highlighted annotations throughout the margins. The bound file features eight pages of printed SPFX notes for production. The two books are "Buddy's Little Self Help Book" and "Elf in the City." This lot exhibits edge fraying and mild corner creasing. Dimensions (largest): 31.75 cm x 29.25 cm x 10.25 cm (12.5" x 11.5" x 4"); (smallest): 12.75 cm x 19.75 cm x .75 cm (5" x 7.75" x 0.25")

Estimate. £2,500 - 3,500



884
Ajihad's (Djimon Hounsou) Stunt
Shield M
Eragon (2006)

Ajihad's (Djimon Hounsou) stunt shield from Stefen Fangmeier's fantasy adventure Eragon. Ajihad used his shield during the climactic battle against the army lead by Durza (Robert Carlyle). Made of foam rubber, the round shield features rivet detailing, spikes along half its edge, and an ornate decorative pattern. It is finished in amber and silver-coloured paint, with two leather straps attached to the back. Some of the small rivets around the edge display minor damage, and the silver paint has worn away in places. Dimensions: 35 cm x 51 cm x 6 cm (13 1/4" x 20" x 2 1/4")

Estimate. £600 - 800

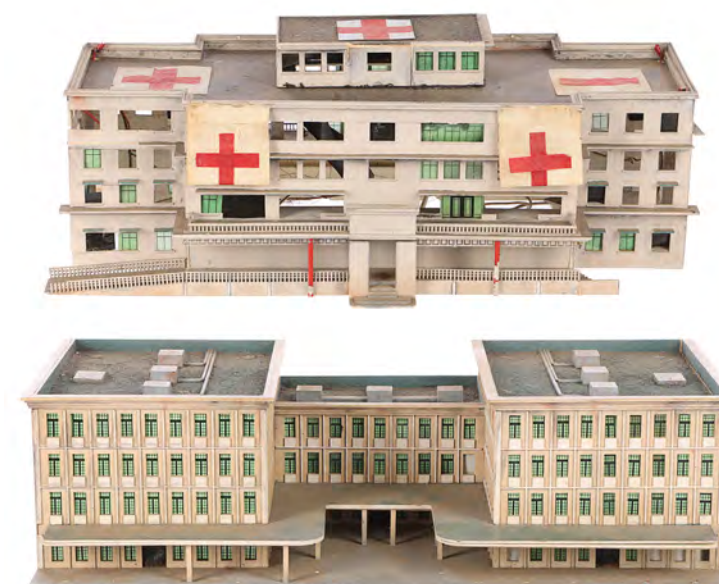

885
Pair of Model Miniature Buildings M
Escape From New York (1981)

A pair of model miniature buildings from John Carpenter's sci-fi action film Escape from New York. Miniature buildings were used throughout the film to create extensive and detailed shots of Manhattan. Several different scales were used for different angles, and these particular models were created for an overhead shot, when Snake Plissken (Kurt Russell) flew the glider over the city. Both models are constructed from panels of plastic board. They feature translucent plastic windows, with non-functioning grain-of-wheat bulbs hidden inside. One model appears to be a four-storey office building, while the other is a five-storey hospital complete with paper red cross banners. The pair show wear from production and further damage to the windows and structure from their time spent in storage. Dimensions (office building): 47.5 cm x 22 cm x 12 cm (18 3/4" x 8 1/2" x 4 3/4"); (hospital building): 44 cm x 29 cm x 16 cm (17 1/4" x 11 1/2" x 6 1/4")

Estimate. £3,000 - 5,000



886
Cast-Autographed Poster Ω
Evil Dead, The (1981)

A poster autographed by the cast of Sam Raimi's horror classic The Evil Dead. Posters and lobby cards featuring Bridget Hoffman were distributed to promote the theatrical release, though Hoffman did not appear in the film. This glossy colour poster featuring Hoffman with a chainsaw is signed in silver-colour ink by Raimi, Bruce Campbell (Ash Williams), Betsy Baker (Linda), Theresa Tilly (Sarah York), Scott Spiegel (Fake Shemp), and Ellen Sandweiss (Cheryl Williams). The top left corner exhibits fold lines and creasing. Dimensions: 35.75 cm x 43.25 cm (14" x 17")

Estimate. £500 - 700



887
MetaFlesh GamePod and UmbyCord with Ted Pikul's (Jude Law) Trout Farm ID and Trout Puppets Ω
Existenz (1999)

A MetaFlesh GamePod and UmbyCord with Ted Pikul's (Jude Law) trout farm ID and trout puppets from David Cronenberg's sci-fi thriller eXistenZ. After using his biomechanical UmbyCord to plug into the MetaFlesh GamePod, Pikul awoke as Larry Ashen, a butcher at a mutant trout farm. This lot consists of an otherworldly pink silicone GamePod with a matching cable wrapped in peach-coloured silicone; a plastic "Trout Farm" ID with a picture of Pikul/Ashen; and two hand-painted silicone, foam latex, and plastic trout puppets. The larger fish contains a nonfunctional battery pack. The lot exhibits some residual stickiness, odour, tears, scratches, and fragility from production. Dimensions: 66.25 cm x 35.75 cm x 7.75 cm (26" x 14" x 3") Contains mechanical components; see notice in the Buyer's Guide.

Estimate. £1,500 - 2,500



888
Moses' (Christian Bale) Cavalry Underarmour $\dagger\Delta$
Exodus: Gods And Kings (2014)

Moses' (Christian Bale) cavalry under armour from Ridley Scott's Biblical epic Exodus: Gods and Kings. Moses wore his under armour while fighting alongside Ramses (Joel Edgerton). The armour comprises hundreds of small resin plates, which are painted to look like metal scales and adhered to fabric. The armour is fastened with leather lacing, though its right side has a section cut out of it so it cannot be fastened.

Estimate. £600 - 800



889
Secret Ritual Orgy Cloak M
Eyes Wide Shut (1999)

A secret ritual orgy cloak from Stanley Kubrick's erotic drama Eyes Wide Shut. Attendees wore cloaks during the masked secret society orgy, which Dr William Harford (Tom Cruise) attended after learning that his wife Alice (Nicole Kidman) had previously contemplated an affair. The long cloak is made from black cotton twill fabric, and features a cape, collar, and hood lined in black satin. A hook-and-eye clip fastening is present at the front, and there are some minor stains on the satin lining. The lot is accompanied by an Angels Costumes certificate of authenticity.

Estimate. £1,000 - 1,500

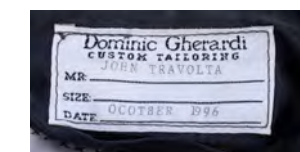

890
Castor Troy-as-Sean Archer (John Travolta) Suit & Accessories M
Face/Off (1997)

Suit and accessories worn by Castor Troy (Nicolas Cage) in the guise of Sean Archer (John Travolta) from John Woo's action thriller Face/Off. Terrorist Castor Troy wore this suit while wearing the face of FBI agent Sean Archer, most notably when he disarmed his own bomb to become an "American Hero" and take over Archer's life. This lot consists of a blue custom Dominic Gherardi three-piece suit; a Giorgio Armani purple-and-gold-striped tie; a pair of mismatched cufflinks; and a gold-tone tie clip. The suit displays no sizing, but features "John Travolta, October 1996" printed on the tailor's labels sewn into the waistcoat and trousers. The jacket exhibits a minor stain on the collar.

Estimate. £3,000 - 5,000



891
The Thing (Michael Chiklis) Facial Prosthetic and SFX Hands M
Fantastic Four (2005)

The Thing's (Michael Chiklis) facial prosthetic and SFX hands from Tim Story's superhero film Fantastic Four. After being exposed to cosmic radiation, Ben Grimm (Michael Chiklis) and his three companions became infused with superpowers, with Ben becoming a creature of stone known as The Thing. Chiklis, being a devout fan of The Thing since childhood, fought eagerly to protect the character from being CGI. He wore over 20kg of prosthetics which took three hours to apply. The lot comprises of a foam latex head appliance and matching gloves painted orange with detailing such as cracks and rough edges to look like rocks. The head appliance is made up of several pieces that have since been stuck together to make a complete bust and the gloves have partings in the palms that fasten with Velcro and metal button fasteners around the wrists. The gloves each have a handwritten label reading "Michael C #2"; a pair of hand extenders made from vac-formed plastic for the backs of the hands; and carbon fibre and resin moulded into finger segments. These segments are then joined with a mechanism that allows the wearer to control each digit. They feature the handwritten label "Michael" and several other number references on each finger section.

Estimate. £3,000 - 5,000



892
Victor Von Doom (Julian McMahon) BusinessWeek Magazine Cover Ω
Fantastic Four (2005)

A BusinessWeek magazine cover featuring Victor Von Doom (Julian McMahon) from Tim Story's superhero film Fantastic Four. A copy of BusinessWeek featuring the future Dr. Doom sat on his bathroom vanity while he stood at his mirror. This production-made, colour-printed glossy BusinessWeek magazine cover features a statue of Von Doom and the headline "Space Disaster Crashes Von Doom Industries." The interior pages feature a story headlined "The Golden Boy Tarnished" alongside a picture of Von Doom, and the back cover features an ad for "Cisco Systems." It exhibits scuffing on the back cover and staple holes from its initial binding. Dimensions: 21.75 cm x 28 cm (8.5" x 11")

Estimate. £800 - 1,200



893
Set of Three Dominic Toretto (Vin Diesel) Licence Plates Ω
Fast And The Furious, The (2001)

Three Dominic Toretto (Vin Diesel) licence plates from Rob Cohen's crime action drama The Fast and the Furious. Street racing legend Toretto drove his father's 1970 Dodge Charger R/T and two 1970 Chevrolet Chevelle SSs throughout the film. This lot consists of three plastic California licence plates: one numbered "2JRI424"; another numbered "2JRI424" and labelled "Dom's Charger"; and one numbered "290QKH" and labelled "sc. 71 Laura's Prius" when it was later used for the production of Judd Apatow's romantic comedy Knocked Up. The "Dom's Charger"-labelled plate is extensively distressed with grime and scratches by production. Dimensions (each): 31.25 cm x 16 cm (12.25" x 6.25")

Estimate. £800 - 1,200



894
Colonel Nathan Jessop's (Jack Nicholson) Military Shirt and Badges
M
A Few Good Men (1992)

Colonel Nathan Jessop's (Jack Nicholson) military shirt and badges from Rob Reiner's legal drama A Few Good Men. Colonel Jessop wore his military shirt and badges during Kaffee's (Tom Cruise) visit to the Guantanamo Bay Navy Base in Cuba and later during the trial as part of his Class A dress uniform. The khaki short sleeve shirt is labelled size "L" and features a prominent badge of rank ribbons and a silver-tone metal marine pin on each collar. It includes a Marine Shop production label displaying a faint "Jessep" [sic] handwritten in black pen. Three pin backs off the rank ribbons badge are missing.

Estimate. £3,000 - 5,000



895
Korben Dallas' (Bruce Willis) Winning Contest Ticket \mathcal{M}
Fifth Element, The (1997)

Korben Dallas' (Bruce Willis) winning contest ticket from Luc Besson's sci-fi adventure The Fifth Element. General Munro (Brion James) rigged the annual Gemini Croquette Contest, so Korben Dallas would win and receive the prize: two tickets to board the space cruise ship Fholston Paradise. Munro ambushed Dallas' apartment and presented him with the tickets. The two clear acetate tickets feature the flight details and Dallas' name. They both sit on top of a yellow card with a semi-circular "Winner" title which pops up when slid out of the envelope via two small springs. The tickets come presented in an open "NYC Mail" envelope housed in a plastic sleeve. There are small holes and signs of wear on the plastic sleeve. Dimensions (in envelope): 24 cm x 11 cm x 0.5 cm (9 1/2" x 4 1/4" x 1/4")

Estimate. £2,000 - 3,000



896
Fholston Paradise Sailor Uniform $\pm\Delta$
Fifth Element, The (1997)

A Fholston Paradise sailor uniform from Luc Besson's sci-fi adventure The Fifth Element. Sailors wore their outfits as they worked aboard the Fholston Paradise vacation space cruise ship where Korben Dallas (Bruce Willis) was sent to retrieve the four elemental stones. Designed by Jean Paul Gaultier in his signature sailor design, the costume consists of a white cap; a navy tunic decorated with a gold-coloured embroidered Fholston Paradise logo (labelled size XL); a white-and-navy striped turtleneck, a pair of white gloves; a pair of white shorts (labelled size W32); and a pair of black boots. The tunic features detachable sleeves and gold-coloured foam epaulettes.

Estimate. £800 - 1,200



898
Support Group Meeting Schedule \mathcal{M}
Fight Club (1999)

A support group meeting schedule from David Fincher's comedy thriller Fight Club. In an attempt to cure his chronic insomnia, the Narrator (Edward Norton) attended various support groups while pretending to suffer from multiple diseases, and grabbed a meeting schedule from the church notice board to plan out his week. The white sheet of paper features a list, printed in black, of meetings for each day of the week, with the text "St. Christopher Episcopal Church" printed along the top. Each entry includes the time, the group's name, and the location. The lot is accompanied by a 20th Century Fox certificate of authenticity. Dimensions: 28 cm x 21.5 cm (11" x 8 1/2")

Estimate. £800 - 1,200



897
Diva Plavalaguna Concert Ticket \mathcal{M}
Fifth Element, The (1997)

A Diva Plavalaguna (Maiwenn) opera ticket from Luc Besson's sci-fi adventure The Fifth Element. Korben Dallas (Bruce Willis) picked up and held a ticket when he arrived at his suite on the Fholston Paradise luxury cruise spaceship. The ticket is printed on cardstock paper, with the concert details written in white and yellow on a red background featuring a graphic motif. The ticket is creased. Dimensions: 19.5 cm x 9 cm (7 3/4" x 3 1/2")

Estimate. £600 - 800



899
Ming Palace Guard's Helmet $\pm\Delta$
Flash Gordon Conquers The Universe (1940)

A Ming palace guard's helmet from Ford Beebe and Ray Taylor's 1940 sci-fi movie serial Flash Gordon Conquers the Universe. Guards wore their helmets in the sixth chapter, "Flaming Death," while onboard Prince Barin's (Roland Drew) fleet ship, which mistakenly shot and pursued Flash's (Buster Crabbe) stolen craft. The gold-coloured painted metal helmet features a tall, oyster-like crest on the top, rivet-like detailing and a padded felt band marked "7 3/8" lines the inside. The paint has chipped away in several places, exposing the metal underneath; there is a dent in the front, and the left strap has detached. Minor scuffs and loose paint are present. Dimensions: 20 cm x 23 cm x 40 cm (8" x 9" x 15 3/4")

Estimate. £600 - 800



900
Ming Royal Guard Costume +
Flash Gordon (1980)

A Ming royal guard costume from Mike Hodges' sci-fi adventure Flash Gordon. Emperor Ming's (Max von Sydow) royal guards wore their costumes throughout the film, most notably when Flash (Sam J. Jones) and his companions first entered Ming's palace, and later during Ming and Dale's (Melody Anderson) wedding. The costume comprises a fibreglass helmet, breastplate and back armour; a red quilted jacket; a pair of bracers; a pair of matching red trousers featuring faux-fur detailing; three decorative leg armour plates; and a pair of greaves. The fibreglass armour components are finished in gold-coloured paint with red detailing, and feature small leather straps and buckles. There are signs of damage to the helmet, some buckles are missing, and the gold finish has worn away on some of the armour.

Estimate. £3,000 - 5,000



901
Hawkman Soldier Blaster M
Flash Gordon (1980)

A Hawkman soldier blaster from Mike Hodges' sci-fi adventure Flash Gordon. Hawkmen carried their rifles in Sky City, where the death match between Flash (Sam J. Jones) and Prince Barin (Timothy Dalton) took place, and used them while attacking the War Rocket Ajax during the film's climax. The weapon is predominantly made of cast fibreglass and is painted black and gold. Wing detailing adorns the barrel, and the blaster features a ridged guard with a decorative curved section attached to the bottom. The lot is missing a feather-shaped guard, and a piece from the barrel. Dimensions: 72 cm x 7 cm x 21 cm (28 1/4" x 2 3/4" x 8 1/4")

Estimate. £1,500 - 2,500



902
Hawkman Cannon M
Flash Gordon (1980)

A Hawkman cannon from Mike Hodges' sci-fi adventure Flash Gordon. Cannons were wielded by the Hawkmen, including their leader Prince Vultan (Brian Blessed), while attacking the War Rocket Ajax alongside Flash Gordon (Sam J. Jones). Constructed of black and gold-painted fibreglass, this cannon features an extended hollow barrel with a decorative shoulder guard, a feather-patterned grip and a static trigger. An oversized sight is attached to the top of the barrel; this has become damaged over time. The lot exhibits signs of chipping to the paint finish and minor damage to the detailing at the tip of the barrel. Dimensions: 94 cm x 30 cm x 38 cm (37" x 11 3/4" x 15")

Estimate. £1,500 - 2,500



903
Ming Soldier Blaster M
Flash Gordon (1980)

A Ming soldier blaster from Mike Hodges' sci-fi adventure Flash Gordon. Swords and rifles formed part of the armoury aboard the War Rocket Ajax, with the guards of Ming the Merciless (Max von Sydow) using rifles to protect their ship and emperor. The black-painted weapon is made of fibreglass and foam rubber around a wooden core. It is decorated with gold-and-red foil detailing, features a solid trigger, and has a leather carrying strap attached. Several of its foil decals have begun to peel, and the paint has flaked away, exposing the foam on the stock. Dimensions: 66 cm x 7 cm x 24 cm (26" x 2 3/4" x 9 1/2")

Estimate. £1,500 - 2,500



905
Plaster Trimaxion Drone Model Miniature Ω
Flight Of The Navigator (1986)

A plaster Trimaxion Drone model miniature from Randal Kleiser's sci-fi adventure Flight of the Navigator. The Trimaxion Drone transported David Freeman (Joey Cramer) eight years into the future to access the alien star charts in his mind. This bisque plaster model, created for reference and hand-painted silver-colour during pre-production, originated with production company Producers Sales Organization [sic] (PSO). It features decorative engravings along the hull which match pre-production drawings, as well as an arrow indicating "FWD" in light pink text. The miniature exhibits some chipping in the plaster and paint from production. Dimensions: 37 cm x 33.25 cm x 19.25 cm (14.5" x 13" x 7.5")

Estimate. £1,000 - 1,500



904
Vacuum-Formed Plastic Trimaxion Drone Model
Miniature Ω
Flight Of The Navigator (1986)

A vacuum-formed plastic Trimaxion Drone model miniature from Randal Kleiser's sci-fi adventure Flight of the Navigator. The Trimaxion Drone transported David Freeman (Joey Cramer) eight years into the future to access the alien star charts in his mind. This plastic model, created for reference and hand-painted silver-colour during pre-production, originated with production company Producers Sales Organization [sic] (PSO). It features a more elongated body and prominent top ridge than the Drone ultimately seen onscreen. The ship exhibits some cracks along the seam, scratched plastic, paint chipping, and discolouration from production and storage. Dimensions: 36.25 cm x 26.75 cm x 12.75 cm (14.25" x 10.5" x 5")

Estimate. £800 - 1,200



114 cm (45")

906
Set of Five Maquettes M
Flintstones, The (1994)

A set of five maquettes from the production of Brian Levant's comedy The Flintstones. Maquettes were supplied for the film by Jim Henson's Creature Shop and were used by the visual-effects department as master reference for colour matching and CGI modelling. The set comprises a green-and-brown brontosaurus; a green-and-brown "pigasaurus"; a brown mammoth; a red hedgehog-like creature climbing a tree stump on a black wooden base; and a red-and-black armadillo-like creature on a black wooden base, in the corner of which is the "Jim Henson Creature Shop London" logo. A brontosaurus appeared as Fred Flintstone's (John Goodman) bronto-crane at his Slate & Co workplace, while the Flintstone home had a pigasaurus waste disposal unit and a mammoth shower head. The maquettes are made of cast resin, and the mammoth and pigasaurus have acrylic eyes. Expertly painted, the maquettes exhibit highly intricate detailing and texturing. Dimensions (largest): 114 cm x 21 cm x 32 cm (45" x 8 1/2" x 12 1/2")

Estimate. £3,000 - 5,000



907
 Professor Philip Brainard's (Robin Williams) Miniature House Model +
Flubber (1997)

A miniature house model from Les Mayfield's sci-fi comedy Flubber. This model is a large-scale miniature of Professor Philip Brainard's (Robin Williams) home, where he worked on scientific experiments that resulted in his accidental creation of the green substance Flubber. The model comprises the main house and a separate garage, all made from a mix of wood and resin, with acrylic windows and no base. The windows feature paper curtains or false interiors glued to the inside, and the garage has "#1 Prof House" handwritten in pen on the interior. This lot exhibits significant wear from production use and age, including dirt marks, peeling paint, unstuck panels, glue remnants and a missing garage roof. Dimensions (house only): 89 cm x 86 cm x 58.5 cm (35" x 33 3/4" x 23")

Estimate. £500 - 700



909
 Ngoc Minh Quan's (Jackie Chan) Stunt AR-18 with Improvised Suppressor +
Foreigner, The (2017)

Ngoc Minh Quan's (Jackie Chan) stunt AR-18 with improvised suppressor from Martin Campbell's action film The Foreigner. Quan smuggled his weapon into an IRA hideout while disguised as a handyman. The weapon is a hard rubber AR-18 and it features a suppressor made to look like a cola can wrapped in fabric. Some of the paint has worn in places and there are imperfections in the rubber from casting, most notably at the back of the rifle. Dimensions: 57.5 cm x 8 cm x 22 cm (22 3/4" x 8 1/4" x 8 3/4") Restricted ownership; see replica firearm notice in the Buyer's Guide.

Estimate. £600 - 800



908
 Seth Brundle (Jeff Goldblum) Shed Ear, Fingernails and Broken Wrist Prosthetics +
Fly, The (1986)

Seth Brundle's (Jeff Goldblum) shed ear and fingernails, and a broken wrist prosthetic from David Cronenberg's sci-fi horror The Fly. Prosthetics were used throughout the film, including the body parts shed by Brundle as his body was consumed by housefly DNA, after a teleportation mishap. This set features a resin ear with latex flesh that was seen in Seth's bathroom cabinet alongside various other shed body parts, and a set of five resin fingernails that Seth peeled off when he first began his transformation. It also includes a broken wrist prosthetic made of resin and fibreglass that was used in the scene where Seth broke Marky's (George Chuvalo) wrist during an arm-wrestling match. The ear and fingernails are displayed in acrylic boxes affixed to a frame alongside a still from the film. Dimensions (display): 23 cm x 21.5 cm x 4 cm (9" x 8 1/2" x 1 1/2"); (wrist): 13.5 cm x 8.5 cm x 3 cm (5 1/4" x 3 1/2" x 1")

Estimate. £2,000 - 3,000



910
 Forrest Gump's (Tom Hanks) Floating Feather +
Forrest Gump (1994)

Forrest Gump's (Tom Hanks) feather from Robert Zemeckis' historical drama Forrest Gump. During the film's opening scene, a feather fell at Forrest's feet, before he picked it up and placed it inside a book. Though a computer-animated feather was created for shots showing motion, a real one was used for Hanks to interact with. This is a production feather, but does not match the one Forrest held in close up. This feather features a white rachis, fluffy white downy lower barbs, and grey-striped barbs near the tip. Dimensions: 9.5 cm x 4 cm (3 3/4" x 1 1/2")

Estimate. £2,000 - 3,000



911
 Forrest Gump's (Tom Hanks) Letter from Apple +
Forrest Gump (1994)

Forrest Gump's (Tom Hanks) letter from Robert Zemeckis' historical drama Forrest Gump. Forrest received a letter from "fruit company" Apple Computer, Inc. after Lieutenant Dan (Gary Sinise) invested their shrimp earnings in its stock. This lot consists of a letter typewritten on Apple Computer, Inc. letterheaded paper dated "September 23, 1975" and addressed to "Mr. Forrest Gump" by "J. Wellington Bigby, Chief Financial Officer," as well as a corresponding Apple Computer, Inc. envelope with a Cupertino, CA stamp. The letter is folded into thirds and the envelope comes unsealed. Dimensions (letter): 28 cm x 21.5 cm (11" x 8 1/2")

Estimate. £2,000 - 3,000



913
 Forrest Gump's (Tom Hanks) Army Certificate of Appreciation and
 Mama Gump's (Sally Field) Pill Bottle +
Forrest Gump (1994)

Forrest Gump's (Tom Hanks) Army Certificate of Appreciation and Mama Gump's (Sally Field) pill bottle from Robert Zemeckis' historical drama Forrest Gump. Although not obviously seen on screen, Forrest's certificate is in recognition of his "faithful performance of duty" in the army. Mama Gump had pill bottles on her bedside table after she fell ill. The certificate is in a metal frame and is dated "23 July 1974". The pill bottle is made of plastic and has a paper label with pharmaceutical information taped to it. The certificate has some marks and minor staining. Dimensions (framed certificate): 20.5 cm x 26 cm x 1 cm (8" x 10 1/4" x 1/2")

Estimate. £600 - 800



912
 Uncut Forrest Gump (Tom Hanks) and Lieutenant Dan (Gary Sinise) Fortune Magazine Cover +
Forrest Gump (1994)

A Forrest Gump (Tom Hanks) and Lieutenant Dan (Gary Sinise) Fortune magazine cover from the production of Robert Zemeckis' historical drama Forrest Gump. Forrest showed off a magazine cover featuring him and Dan to a woman at the bus stop, while explaining the history of the Bubba-Gump Shrimp Company. This production-made, single-sided paper cover depicts Forrest and Dan with a giant tub of Bubba-Gump Shrimp cocktail, and is dated "November 1974", with an Ettlne advertisement printed on the opposite side. It remains uncut and unfolded. Dimensions: 33 cm x 52.5 cm (13" x 20 3/4")

Estimate. £1,500 - 2,500



914
 Three Greenbow County Police Badges, Production Sign and Four Crew T-Shirts +
Forrest Gump (1994)

Three Greenbow County police badges, a production sign and four crew T-shirts from the production of Robert Zemeckis' comedy-drama Forrest Gump. Although not seen on screen, the police badges are aluminium with pins on the back and are labelled "Chief", "Deputy" and "Officer". The card production sign features the film's title and a silhouette of Forrest on a bench. Three of the four crew T-shirts are labelled "Large" and one is unlabelled. The T-shirts have minor staining and one has a small hole. Dimensions (production sign): 14 cm x 35.5 cm (5 1/2" x 14")

Estimate. £600 - 800

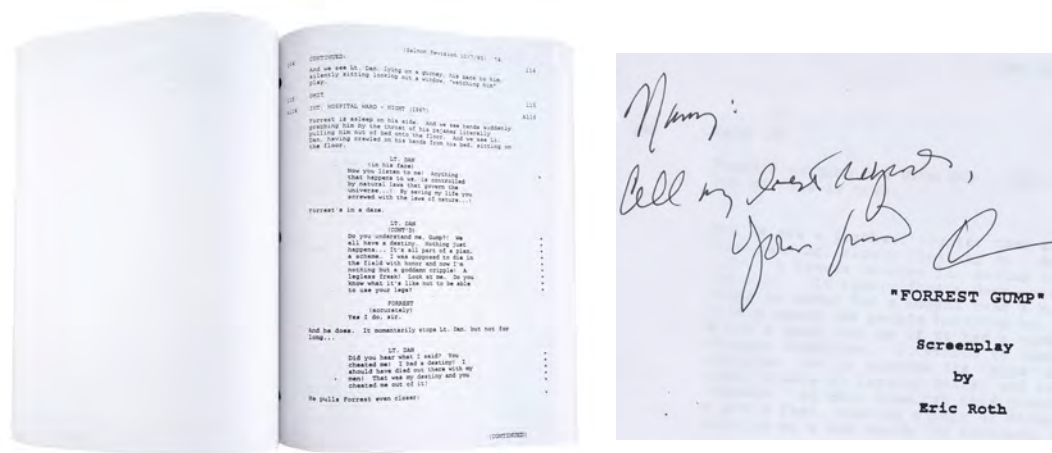

915
Eric Roth-Autographed Bound Final Shooting Script Ω
Forrest Gump (1994)

A bound final shooting script from Robert Zemeckis' Oscar-winning comedic drama Forrest Gump autographed by Eric Roth. Roth won the Academy Award for Best Writing for his adaptation of the novel by Winston Groom. This brass brad-bound, 151-page final shooting script is dated "12/9/93" and hand-signed "Nancy, all my best regards, your friend" in ink by Roth on the cover page. Also included is a Letter of Authenticity from the colleague to whom Roth gifted the script between 1994 and 1996. The script exhibits minor creasing at the corners and discolouration from production use and age. Dimensions: 23 cm x 28 cm x 2.75 cm (9" x 11" x 1")

Estimate. £600 - 800

916
Cyborg Machine Gun M
Fortress (1992)

A cyborg machine gun from Stuart Gordon's sci-fi action film Fortress. Cyborg prison guards wielded arm-mounted machine guns, and John Brennicks (Christopher Lambert) used one as he escaped the futuristic prison of the title. The three-barrelled weapon is made predominantly of resin, with two foam-and-resin cartridge belts. The gun features a hole in the back and an internal bar, which allows the wearer to hold it over their arm. It also has a small torch at the top. The gun has some paint wear and the section around the torch shows signs of repair. Dimensions: 62 cm x 37 cm x 24 cm (24 1/2" x 14 1/2" x 9 1/2") Contains electronics; see electronics notice in the Buyer's Guide.

Estimate. £1,000 - 1,500

917
Set of Nine Hand-drawn Storyboards M
Fraggle Rock: The Animated Series (T.V. Series, 1987 - 1988)

A set of hand-drawn storyboards from the production of Jim Henson's children's TV series Fraggle Rock: The Animated Series. This particular set depicts moments from episode five, Mokey's Flood of Creativity/What the Doozers Did. The set comprises nine sheets of paper, each featuring six panels of hand-drawn scenes sketched in blue pencil and graphite. "Marvel Productions, LTD." is printed along the top of all nine pages, and a brief description is situated under each storyboard. The sheets are numbered 50 to 59, with 52 missing from the set. Dimensions: (each sheet) 35.5 cm x 21.7 cm (14" x 8 1/2") Sold without copyright; see notice in the Buyer's Guide.

Estimate. £400 - 600



THE MARIO KIRNER COLLECTION

The following 21 lots come from the Friday the 13th Props Museum collection of Mario Kirner. The Museum was created as a private collection that showcased not only Jason's iconic hockey mask, but also a number of other movie props, costumes and additional materials that were used during the production of the Friday the 13th movies.

An avid contributor in the screen-used prop and costume collecting field for more than 20 years, Mario Kirner has been a dedicated in his work and efforts to help to transform what was once a niche hobby into a popular culture phenomenon. Mario is not just a collector, but a true historian and curator of all things Jason Voorhees and Friday the 13th, also publishing a book dedicated to showcasing the museum's content and their stories. Additional lots from the collection can be found on Day 1 of the auction.



918
Mario Kirner Collection: Chuck's (David Katims) Screen-matched Shirt Ω
Friday The 13th Part III (1982)

Chuck's (David Katims) screen-matched shirt from Steve Miner's slasher sequel Friday the 13th Part III. Chuck wore his shirt from the scene where he used the outhouse to the moment Jason Voorhees (Richard Brooker) killed him by throwing him into the fuse box. The shirt screen-matches the one on screen through the placement and pattern of the purple line near one side seam. This shirt originally came from the personal collection of actor David Katims, and it's believed to be the only costume piece known to still exist from the film. The cotton shirt is marked size "L" and features different-coloured stripes, several of which have faded over time. It comes with a tag reading "FRI,13 3D Katims, David, #8766". After production, a seamstress carried out repairs on the shirt, including the removal of the lining of one chest pocket to create two patches sewn onto the back. There are marks and stains present on the lot.

Estimate. £1,000 - 1,500



919
 Mario Kirner Collection:
 Head Cowl Ω
**Friday The 13th Part VI:
 Jason Lives (1986)**

A head cowl from Tom McLoughlin's slasher sequel Friday the 13th Part VI: Jason Lives. Once Jason (C.J. Graham) was resurrected by a lightning strike and murdered Allen (Ron Palillo) in the film's opening scenes, he covered his rotting face with the infamous hockey mask that Tommy (Thom Mathews) had brought with him to the graveyard. Only one head cowl is known to exist from this production. The cowl is made of foam latex, and painted in blue and grey shades to give the appearance of zombie-like rotting flesh. It features a hole cut away around the centre of the face since the hockey mask covered it in most scenes. The cowl has become brittle around the edges, exhibiting minor areas of flaking paint, and comes presented on a foam rubber cast bust of Graham. Dimensions: 28 cm x 46 cm x 39 cm (11" x 18" x 15 1/4")

Estimate. £2,000 - 3,000



920
 Mario Kirner Collection: Jason
 Voorhees' (Kane Hodder)
 Hand Appliance Ω
**Friday The 13th Part VII: The New
 Blood (1988)**

Jason Voorhees' (Kane Hodder) hand appliance from John Carl Buechler's slasher sequel Friday the 13th Part VII: The New Blood. Serial killer Jason appeared throughout the film covered in rotting flesh, a design choice by the effects team to reflect the fact that he had been killed and risen from the dead in previous chapters. Actor Kane Hodder wore a complete foam-rubber undersuit, including gloves, beneath his costume. This glove is made of foam rubber and is finished to resemble exposed bones and decayed skin. The foam rubber has become brittle over time, and small patches have crumbled away. The lot remains fragile and should be handled with care. Dimensions: 29 cm x 16 cm x 6 cm (11 1/2" x 6 1/4" x 2 1/4")

Estimate. £700 - 900



921
 Mario Kirner Collection: Jason
 Voorhees' (Kane Hodder)
 Set of Teeth Ω
**Friday The 13th Part VII:
 The New Blood (1988)**

A set of Jason Voorhees' (Kane Hodder) teeth from John Carl Buechler's slasher sequel Friday the 13th Part VII: The New Blood. Towards the end of the movie, Tina (Lar Park-Lincoln) used her telekinetic powers to break Jason's mask, revealing some of his teeth. These teeth were the only set made for Hodder, to wear with his facial make-up appliances. Made of plastic, each row of teeth comprises a mouthguard with a discoloured protruding section featuring spaced-out teeth. Hodder has autographed one row in black marker and has written "Jason" on the other. There are signs of minor repair on one row, where a small crack is present. Dimensions (one set): 7 cm x 10 cm x 4 cm (2 3/4" x 4" x 1 1/2")

Estimate. £700 - 900

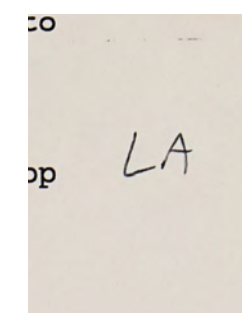
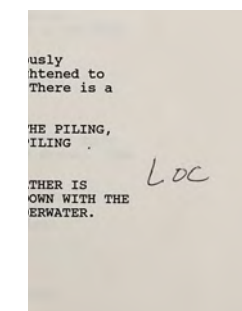
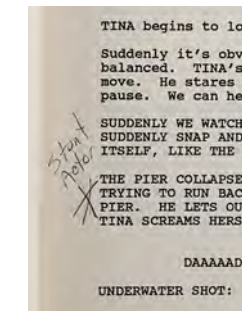
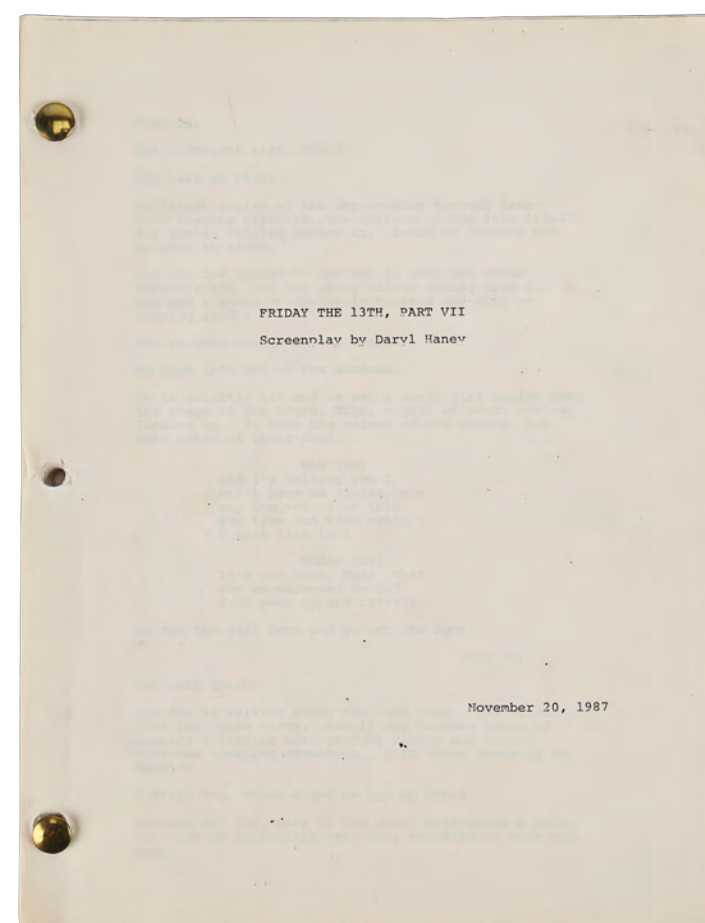

922
 Mario Kirner Collection:
 Kane Hodder's Personal
 Hand Annotated Script Ω
**Friday The 13th Part VII:
 The New Blood (1988)**

Kane Hodder's personal hand annotated script from the production of John Carl Buechler's slasher sequel Friday the 13th Part VII: The New Blood, in which Hodder starred as Jason Voorhees. Bound by brass fasteners, the document is credited to Daryl Haney and is dated "November 20, 1987". The script consists of 91 pages, and the text "Friday 13th - VII, partial revision, 11/20/87" is printed along the top of each page. Hodder has annotated some pages, which have the corners folded down, and "Friday VII, 11/20" is written along the spine. There are minor tears near the hole punches on the cover page. Dimensions: 28 cm x 22 cm x 1.5 cm (11" x 8 1/2" x 1/2")

Estimate. £1,500 - 2,500



923
 Mario Kirner Collection: John Carl Buechler's Personal Shooting Script [Ω](#)
Friday The 13th Part VII: The New Blood (1988)

John Carl Buechler's personal shooting script from the production of his slasher sequel Friday the 13th Part VII: The New Blood. The script is dated "10/13/87" and is credited to Daryl Haney, who only completed the first draft, which was subsequently heavily revised. The 108-page document comes in a black leather binder with the title "Friday The 13th, Part 7" and Buechler's name embossed in gold-foil text. "John's Script" is written in pencil on the first page. Changes were made to the script to maintain a veil of secrecy. These alterations included using the film's working title, "Birthday Bash", changing Jason's name to "Ethan", and replacing Crystal Lake with "Shadow Pond". The last page of the script exhibits small tears. Dimensions: 30 cm x 26.5 cm x 4 cm (11 3/4" x 10 1/2" x 1 1/2")

Estimate. £1,500 - 2,500



925
 Mario Kirner Collection: Kane Hodder Autographed Script Revision Pages and Assorted Production Paperwork [Ω](#)
Friday The 13th Part VII: The New Blood (1988)

A set of script revision pages and assorted paperwork autographed by Kane Hodder from the production of John Carl Buechler's slasher sequel Friday the 13th Part VII: The New Blood, in which Hodder played Jason Voorhees. The set comprises 13 orange revision pages dated "1/25/88"; a pink six-page shooting schedule; a blue three-page shooting schedule; two pages of stunt breakdowns; and a schedule. Hodder has autographed most of the paperwork in black ink, and Hodder's name is written in green ink on the script's front page. Presented in a production-used cardboard folder, the lot exhibits some minor stains and fold lines. Dimensions (revision pages): 28 cm x 21.5 cm x 0.2 cm (11" x 8 1/2" x 1/4")

Estimate. £600 - 800

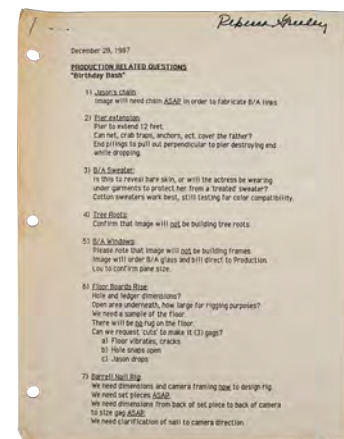

924
 Mario Kirner Collection: List of "Birthday Bash" Production Related Questions [Ω](#)
Friday The 13th Part VII: The New Blood (1988)

A list of "Birthday Bash" production questions from the production of John Carl Buechler's slasher sequel Friday the 13th Part VII: The New Blood. Dated "December 28, 1987", the two sheets feature the film's working title, "Birthday Bash" and a list of questions. The name of credited production manager Rebecca Greeley is handwritten in black ink at the top right corner. Adorning the back is a hand-drawn sketch showing details about the camera set-up for the sequence where Tina (Lar Park-Lincoln) used her telekinesis to electrocute Jason (Kane Hodder) as he lay in a puddle. There are signs of discolouration down the left side. Dimensions: 28 cm x 21.5 cm (11" x 8 1/2")

Estimate. £700 - 900



926
 Mario Kirner Collection: Crew Jacket and Shirt [Ω](#)
Friday The 13th Part VII: The New Blood (1988)

A crew jacket and shirt from the production of John Carl Buechler's slasher sequel Friday the 13th Part VII: The New Blood. Marked as a size M, the bomber jacket is made from black wool, with faux-leather sleeves and a knitted collar and cuffs. Embroidered on the right breast is the name "Solomon", referring to credited production office coordinator Pamela Solomon. The production title is stitched in red on the left breast, and a large image of Jason's hockey mask adorns the back. The light grey Hanes® T-shirt features a black printed image of Jason with the film title on the back and is marked size "L 42-44". The jacket's collar exhibits minor holes.

Estimate. £400 - 600

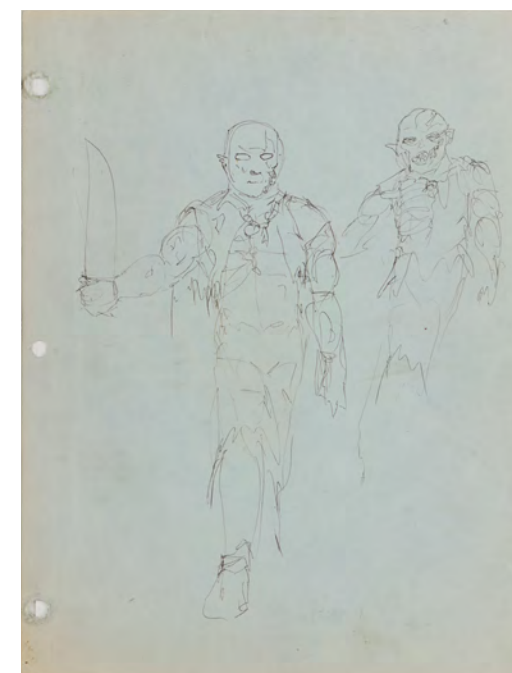

927
 Mario Kirner Collection: Hand-drawn Jason Sketch [Ω](#)
Friday The 13th Part VII: The New Blood (1988)

A hand-drawn sketch of Jason (Kane Hodder) from the production of John Carl Buechler's slasher sequel Friday the 13th Part VII: The New Blood. This lot originally came from the collection of director and special effects supervisor John Carl Buechler, and was sketched on the back page of his script. Rendered in ink on light blue paper, the sketch shows Jason dressed in his mask and tattered clothing, while wielding his machete. The sheet also features a rough sketch of Jason unmasked. It is presented in a silver-coloured frame, and there are signs of discolouration around the edges of the paper. Dimensions: 41 cm x 31 cm x 2 cm (16 1/4" x 12 1/4" x 3/4") Sold without copyright; see copyright notice in the Buyer's Guide.

Estimate. £400 - 600

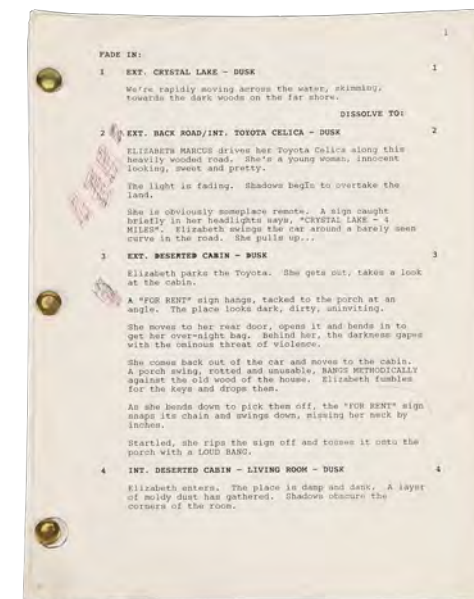

928
 Mario Kirner Collection: Kane Hodder's Personal Annotated Script [Ω](#)
Jason Goes To Hell: The Final Friday (1993)

Kane Hodder's personal annotated script from the production of Adam Marcus' horror sequel Jason Goes to Hell: The Final Friday, in which Hodder stars as Jason Voorhees. This early version of the script has been annotated in ink by Hodder. The script is 97 pages long and is held together with brass fasteners. The pages with annotations have the corners folded down. Dimensions: 28 cm x 22 cm x 1 cm (11" x 8 3/4" x 1/2")

Estimate. £1,500 - 2,500



929
 Mario Kirner Collection: Crew Jumper, Windbreaker and Kane Hodder Autographed Cap [Ω](#)
Jason Goes To Hell: The Final Friday (1993)

A crew jumper, windbreaker and a Kane Hodder-autographed cap from the production and promotion of Adam Marcus' horror sequel Jason Goes to Hell: The Final Friday. These items originated from the personal collection of Kane Hodder (Jason Voorhees). Both the jumper (size "large") and windbreaker (size "S") feature a custom design (by KNB EFX artist Bill Hunt) of the hockey mask, machete and demon dagger in a "Jolly Roger" style. The classic Friday the 13th logo appears each garment. The promotional cap is autographed by Hodder. It features the words "Death Wears Only One Mask" on the back.

Estimate. £600 - 800



930
Mario Kirner
Collection: Jason's
(Kane Hodder) Shirt Ω
Jason X (2001)

Jason's (Kane Hodder) shirt from Jim Isaac's horror sequel Jason X. Jason wore his shirt for much of the film, in which he was cryogenically frozen, before tormenting teens in the future. The shirt is a grey cotton button-up with a grandad-style collar.

Estimate. £2,000 - 3,000



931
Mario Kirner
Collection: Set
Blueprints and Plans Ω
Jason X (2001)

A collection of set blueprints and plans from the production of James Isaac's horror sequel Jason X. After production wrapped, the sets and set designs were purchased by virtual reality company 3001 AD, but later sold in a liquidation sale. This collection comprises six set blueprints and two printed copies of set designs. Two of the blueprints are held in framed displays. Several blueprints have handwritten annotations or sketches, and each of the blueprints has had the movie title and production information cut from the bottom right corner. One of the copies has a shoe print and two pieces of tape stuck to the edges. Dimensions (framed displays): 51 cm x 61 cm x 2 cm (20" x 24" x 3/4")

Estimate. £400 - 600



932
Mario Kirner
Collection:
Promotional
T-Shirts Ω
Jason X (2001)

A pair of T-shirts from the promotion of James Isaac's horror sequel Jason X. Both T-shirts are blue and feature the words "Camp Crystal Lake Counselor" printed on the front, with the film's title printed on the back near the neck. One of the T-shirts also features the logo for Californian radio station KROQ-FM. One T-shirt is size "XL", while the KROQ-FM T-shirt has no size label, and shows some discolouration and minor staining.

Estimate. £300 - 500



933
Mario Kirner
Collection: Kane
Hodder's Crew
T-Shirt, Autographed
Parking Permit and
Photographs Ω
Jason X (2001)

Kane Hodder's crew T-shirt, autographed parking permit and photographs from the production of James Isaac's horror sequel Jason X. The white T-shirt (size XL) displays a stitched motif on the front which combines the poster art for Jason X and the previous film in the franchise, Jason Goes to Hell: The Final Friday. The back of the T-shirt features a list of Jason's victims in the film, although some of the names were changed during the production. There is some very minor staining. The permit features Hodder's signature in silver pen and has several small pin holes. The photographs comprise three Polaroids - each featuring Hodder in his Jason costume with annotations by Hodder himself - and five behind-the-scenes photos showing Hodder on set. Dimensions (permit): 10.5 cm x 26.5 cm (4 1/4" x 10 1/2")



Estimate. £600 - 800



934
Mario Kirner Collection: Camp
Crystal Lake Counselor T-Shirt Ω
Freddy Vs. Jason (2003)

A Camp Crystal Lake counsellor T-shirt from Ronny Yu's horror crossover Freddy vs. Jason. A camp counselor (Tyler Foley) wore his T-shirt during a dream sequence in which Lori (Monica Keena) saw him having sex, before turning into Freddy Krueger (Robert Englund). The T-shirt features the camp's name and logo printed on the front and "Camp Counselor" printed on the back. "Tyler" is handwritten on the label.

Estimate. £400 - 600

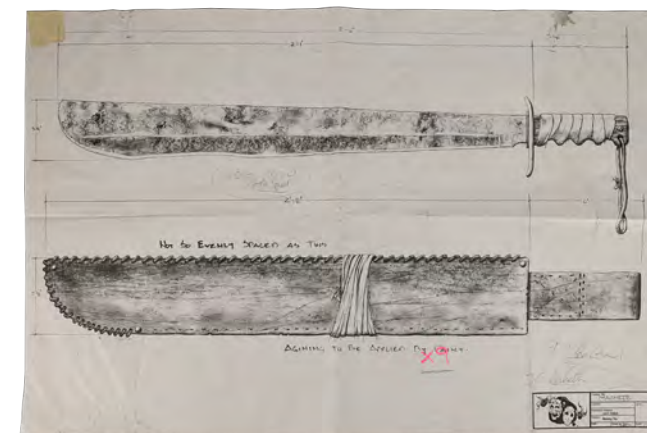

936
Mario Kirner Collection: Jason's (Ken Kirzinger)
Machete Printed Annotated Production Design Ω
Freddy Vs. Jason (2003)

A printed drawing depicting Jason Voorhees' (Ken Kirzinger) machete from Ronny Yu's horror crossover Freddy Vs. Jason. Drawn to a 1-1 scale by production designer John Willett, the illustration shows Jason's signature weapon, a two-and-a-half-foot-long machete, along with an accompanying sheath and some handwritten annotations around the sheath and on the back of the paper. There is creasing to the paper, staining on the reverse side, and it has been folded into rough quarters for storage. Dimensions: 86 cm x 56 cm (34" x 22")

Estimate. £700 - 900



935
Mario Kirner Collection:
Final Draft Script and Shooting Schedule Ω
Freddy Vs. Jason (2003)

A final draft shooting script and shooting schedule from the production of Ronny Yu's horror crossover Freddy vs. Jason. This script is credited to Damian Shannon and Mark J. Swift, and is dated "May 16, 2002" with revisions dated "July 29, 2002". The script is 121 pages long, with an additional 68 pages of shooting schedule added at the end. The collection is held together with brass fasteners and features some minor staining. Dimensions: 28 cm x 22 cm x 2 cm (11" x 8 3/4" x 3/4")

Estimate. £400 - 600



937
Mario Kirner Collection: Jason Voorhees' (Derek Mears)
Hunting Bow and Two Arrows Ω
Friday The 13th (2009)

Jason Voorhees' (Derek Mears) hunting bow and two arrows from Marcus Nispel's slasher reboot Friday the 13th. Jason used a bow to kill Nolan (Ryan Hansen) by piercing his head with an arrow during the wakeboarding sequence with Chelsea (Willa Ford) at Camp Crystal Lake. One of the arrows originally came from the production's property master. Made of metal and wood, the black hunting bow consists of two limbs, a grip section and one cable. The hero arrow comprises a wooden shaft with white-and-brown feather fletching and a white nock. Completing the lot is a stunt rubber arrow featuring a rubber tip and identical fletching. Remnants of stage blood are present on the stunt arrow's feathers, and the lot is accompanied by two Platinum Dunes certificates of authenticity. Dimensions (bow): 25 cm x 4 cm x 144 cm (9 3/4" x 1 1/2" x 56 3/4"); (larger arrow): 87 cm x 3.5 cm x 3.5 cm (33" x 1 1/4" x 1 1/4")

Estimate. £1,500 - 2,500



938
Mario Kirner Collection: Jason Voorhees' (Derek Mears) Teeth and Set of Four Concept Drawings Ω
Friday The 13th (2009)

A set of Jason Voorhees' (Derek Mears) teeth and four printed concept drawings from Marcus Nispel's slasher reboot Friday the 13th. Shots of Mears in his SFX make-up and teeth and the concept designs, feature in behind-the-scenes footage. Credited special effects make-up supervisor Scott Stoddard has stated that this was the only set of teeth made for the production. The lot includes the upper and lower painted acrylic and metal teeth presented on light green teeth moulds labelled "Derek M". There is a stiff loop on one set to keep Mears' upper lip open. The concepts are for Jason's disfigured face, torso, and back. The lot comes with a certificate of authenticity signed by both Stoddard and Mears. Dimensions (each mould): 6 cm x 8 cm x 4 cm (2 ¼" x 3 ¼" x 1 ½")

Estimate. £1,000 - 1,500



940
SFX Tank Shell †Δ
Fury (2014)

A special effects tank shell from David Ayer's war film Fury. Shells were loaded into guns by US tank crews. This shell features a brass cylinder and resin cone. The cone has been hand-painted to look like metal and has "76G TNT Shell M42A1" printed on its side. The shell is designed so that, when loaded into the gun, the cone would slide back into the cylinder, giving it the appearance of being shot upon ejection. The shell has some scuffs and scratches, most notably on the cone, while the brass cylinder is tarnished in places. Dimensions: 82 cm x 8.5 cm x 8.5 cm (32 ¼" x 3 ¼")

Estimate. £300 - 500



939
Three Demon Puppets in Diorama M
Jason Goes To Hell: The Final Friday (1993)

A diorama featuring three demon puppets from Adam Marcus' horror sequel Jason Goes to Hell: The Final Friday. At the climax of the film Jason (Kane Hodder) was dragged into hell by giant demonic hands. In the alternate ending, Jason was dragged into hell by demonic beasts, seen in their entirety. This diorama displays three original rod puppet miniatures alongside a Sideshow replica of Jason and a replica demon. The puppets are made of foam with metal armatures, have been painted to look dusty and dirty, and sit in the diorama's plaster base. The foam around the puppets has cracked in places and the puppets remain in a fragile condition. Dimensions: 36 cm x 33 cm x 16 cm (14 ¼" x 13" x 6 ¼")

Estimate. £800 - 1,200



941
Full-size "Fury" Tank Barrel with Gun Mantlet, Spare Muzzle & Tiger Tank Barrel M
Fury (2014)

Full-size "Fury" and Tiger tank barrels from David Ayer's war film Fury. "Fury" was the titular M4 Sherman tank manned by tank commander Don "Wardaddy" Collier (Brad Pitt) and his crew. The tank barrels are fibreglass and resin. The Tiger's is painted khaki brown and Fury's is painted dark green with the name "Fury" painted in white across it. The Fury barrel comes with a large fibreglass gun mantlet, which is the front panel in which the barrel slots, and a spare unpainted muzzle in two pieces. Dimensions (each barrel): 312 cm x 30 cm x 21 cm (102" x 12" x 8 ¼") Special shipping required: see special shipping notice in the Buyer's Guide.

Estimate. £2,000 - 3,000



942
Set of Fan Convention Promotional Paperwork Ω
Galaxy Quest (1999)

Fan convention promotional paperwork from Dean Parisot's sci-fi comedy Galaxy Quest. The cast of Galaxy Quest attended two conventions, once early in the film and again when The Protector crashed, in which attendees carried Galaxy Quest-themed paperwork. This set of production-made paperwork consists of one colour-printed advertisement for an N.S.E.A. Protector toy; a flyer for a Galaxy Quest Visa credit card; a yellow "QuestCon" flyer featuring Galaxy Quest cast names; and a "Galaxy Quest Galactic Congress (G.Q.C.)" delegate application form. They exhibit light tearing, fold lines, and edge wear throughout. Dimensions (each): 43.25 cm x 28 cm (17" x 11")

Estimate. £400 - 600



943
Wight Mask M
Game Of Thrones (T.V. Series, 2011-2019)

A Wight mask from the fantasy drama TV series Game of Thrones. The zombie-like Wights were seen throughout the series, created by White Walkers reanimating deceased bodies. The mask depicts a decomposed face with visible tendons, a missing nose, decaying teeth, and rotted flesh revealing bone beneath. It is made of latex and silicone painted in brown and green tones, applied to a green stretchy base which features metal hooks around its inside edges to fasten to the performer's costume. The mask comes presented on a black biscuit-foam mannequin head display. Dimensions: 24 cm x 40 cm x 42 cm (9 ½" x 15 ¾" x 16 ½")

Estimate. £2,000 - 3,000



944
Production Continuity Binder
Game Of Thrones (T.V. Series, 2011 - 2019)

A continuity binder from the production of fantasy series Game of Thrones. Wardrobe and script departments maintained continuity binders to ensure visual cohesion throughout the series. This green three-ring binder is labelled "Wyn," likely for principal wardrobe standby Wyn Vaughan-Humphries. It contains 34 colour continuity photos of key cast members, including Sean Bean, Kit Harrington, and Alfie Allen; six costume continuity pages with attached photographs; a character list; and a 26-page Unit List dated "29 July 2010." The binder and paperwork exhibit some staining from use. Dimensions: 25.5 cm x 31.75 cm x 2.75 cm (10" x 12.5" x 1")

Estimate. £1,500 - 2,500



945
Mickey Pearson's (Matthew McConaughey) Pub Costume
Gentlemen, The (2019)

Mickey Pearson's (Matthew McConaughey) pub costume from Guy Ritchie's crime comedy The Gentlemen. Mickey wore his burgundy plaid outfit during the opening scene, where he called his wife Rosalind (Michelle Dockery) from a pub to arrange a date night. The scene was revisited later in the film, when he had to rush to save Rosalind from being attacked by Dry Eye (Henry Golding). The costume consists of a custom-made burgundy plaid woollen blazer; a maroon John Lewis knitted top (size M); a pair of Uniqlo dark wash jeans; a woollen Anderson & Sheppard pocket square; and a pair of burgundy socks. The costume displays some plucked threads on the jeans.

Estimate. £2,000 - 3,000



946
Coach's (Colin Farrell)
Screen-matched Final Tracksuit
Gentlemen, The (2019)

Coach's (Colin Farrell) screen-matched final tracksuit costume from Guy Ritchie's crime comedy The Gentlemen. Coach wore his blue, red and white tracksuit during the climactic scenes at Raymond's (Charlie Hunnam) house. The positioning of the striped pattern near the jacket collar and zip screen matches the costume to the scene where Coach killed two Russian assassins. Costume designer Michael Wilkinson created custom patterns and printed these on quilted technical fabric for all of Coach's tracksuits. The costume comprises a blue zip-up jacket and trousers, decorated with blue, red and white striped trim. A red Lonsdale logo adorns the jacket, and both garments feature a knitted waistband and cuffs. A stain is present on the right cuff.

Estimate. £2,000 - 3,000

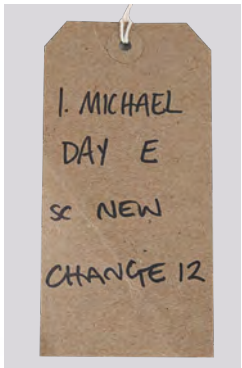

947
Mickey's (Matthew McConaughey)
"Alpha Dance" Tuxedo
Gentlemen, The (2019)

Mickey's (Matthew McConaughey) "Alpha Dance" tuxedo from Guy Ritchie's crime comedy The Gentlemen. Mickey wore his velvet tuxedo while exchanging words with American billionaire Matthew Berger (Jeremy Strong) at a gala dinner. Reporter Fletcher (Hugh Grant) described the conversation as "the alpha dance" when relaying the story to Raymond (Charlie Hunnam). The costume consists of a black velvet Ralph Lauren tuxedo jacket featuring purple lapels and cuffs; a pair of smart black trousers; a black silk Pronto Uomo bow tie; a pair of cufflinks; and eight assorted shirt studs. The cufflinks and studs are presented in a small box labelled "Michael" on the underside. Completing the lot is a white Emporio Armani shirt (collar size 16) which was not seen in the film's final cut. The costume comes with a production wardrobe tag.

Estimate. £1,000 - 1,500



948
Mickey's (Matthew McConaughey) "Snub" Costume †Δ
Gentlemen, The (2019)

Mickey's (Matthew McConaughey) "Snub" costume from Guy Ritchie's crime comedy *The Gentlemen*. Michael wore his costume when he snubbed and refused to shake the hand of the Daily Print newspaper editor Big Dave (Eddie Marsan) at a high-society party. The costume consists of a burgundy velvet tuxedo jacket; a Budd dress shirt (collar size 16½"); a black silk bow tie; four gold plated and white mother of pearl shirt studs; a pair of Gieves & Hawkes black smart trousers (size 34) and a pair of Budd black socks. The studs come presented in a black textured box which is labelled "Michael". The costume shows discolouration around the shirt collar and a minor stain on the jacket's left sleeve.

Estimate. £1,000 - 1,500

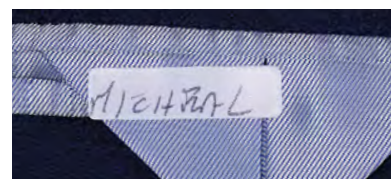

949
Mickey's (Matthew McConaughey)
Striped Tie Costume †Δ
Gentlemen, The (2019)

Mickey's (Matthew McConaughey) striped tie costume from Guy Ritchie's crime comedy *The Gentlemen*. Mickey wore his striped tie outfit when he was presented with a gold Cobra standard derringer by American billionaire Matthew Berger (Jeremy Strong) and his wife Jackie (Lyne Renée). The costume comprises a custom-made navy blue woollen double-breasted blazer; a white Hugo Boss slim-fit shirt (collar size 16); and a navy-and-gold striped silk-knitted tie. "Gary" is written in black ink near the hem on the inside of the shirt.

Estimate. £800 - 1,200

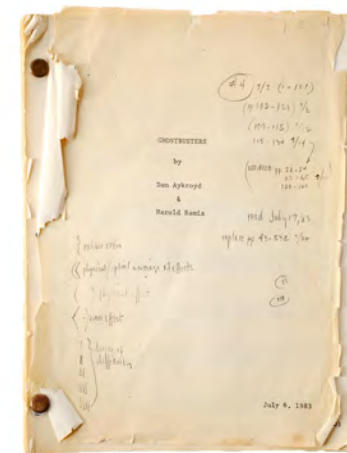

950
Bound Annotated Script Ω
Ghostbusters (1984)

A bound, annotated script from Ivan Reitman's sci-fi comedy *Ghostbusters*. Written by Dan Aykroyd and Harold Ramis, this 134-page script is dated July 6, 1983 and numbered "4" on the cover. This brass brad-bound script also features extensive annotations printed in the margins, some of which note the type of special effects needed and the degree of difficulty regarding those effects. The cover also presents a shooting schedule by grouped pages and dates. The script exhibits tearing, loose pages, and discolouration from production and age. Dimensions: 28 cm x 21.75 cm x 2.5 cm (11" x 8.5" x 1")

Estimate. £2,500 - 3,500



952
Hand-Painted Thom Enriquez
Terror Dog Concept Artwork Ω
Ghostbusters (1984)

Terror Dog concept artwork hand-painted by creature design consultant Thom Enriquez for Ivan Reitman's sci-fi comedy *Ghostbusters*. Gozer the Gozerian (Slavitz Jovan) brought two gargoyles to life as demonic dogs with glowing red eyes. This concept artwork is rendered in mixed media on paper and signed in the bottom right corner by Enriquez. Also included is a loose grey matte board frame. The artwork exhibits some stains in the margins and a folded bottom left corner from handling. Dimensions: 35.75 cm x 33 cm (14" x 13") Sold without copyright; see notice in the Buyer's Guide.

Estimate. £2,500 - 3,500



951
Set of Nine Promotional Stills Ω
Ghostbusters (1984)

Nine stills from the promotion of Ivan Reitman's sci-fi comedy *Ghostbusters*. Columbia Pictures distributed photos to the media as part of its press kits. This set consists of seven glossy stills of the *Ghostbusters* and Reitman printed in black-and-white on photo stock, as well as two colour-printed glossy photos of Peter (Bill Murray) in the courtroom scene. Several photos are numbered in the bottom right corners, and the set exhibits minor staining and creasing. Dimensions (each): 25.5 cm x 20.5 cm (10" x 8")

Estimate. £600 - 800



953
Slimer's Right Hand and Skin Ω
Ghostbusters II (1989)

Slimer's right hand and skin from Ivan Reitman's supernatural comedy sequel *Ghostbusters II*. The glutinous ghost known as both Onionhead and Slimer appeared throughout the film. This lot consists of a hand-painted and textured green foam forearm-length puppeteer's glove with metal clips, a fabric-lined interior labelled "Rehersal [sic]," and brown fingernails; a green elastane-blend opera glove; and foam Slimer skin painted in matching green with stripes and spots. The lot exhibits cracking and crumbling throughout the fingers with the thumb presented loose and the glove stained from production wear. Dimensions: 53.5 cm x 11.5 cm x 6.5 cm (21" x 4.5" x 2.5")

Estimate. £1,000 - 1,500



954
 Maximus' (Russell Crowe)
 Prototype Armour Set M
Gladiator (2000)

Maximus' (Russell Crowe) prototype armour set from Ridley Scott's Oscar®-winning historical epic *Gladiator*. This set features components relative to various armours he wore throughout the film, including the set he wore while commanding the Roman legions during the opening battle, the set he wore as he walked through the Roman encampment, and the set he wore while fighting Tigris of Gaul (Sven-Ole Thorsen) at the Colosseum. The lot comprises chest and back plates made of fibreglass covered in leather; a leather epaulette; and a leather cingulum militare. Adhered to the chest plate are mock-up emblems printed on paper, and both plates are lined with leather. The armour features a pair of leather straps on one side, and has "2" written on the interior. Displayed on a custom-built stand, the armour has been intentionally distressed to appear battle-worn, and some of the paper emblems have begun to peel away. Dimensions (displayed): 25 cm x 39 cm x 98 cm (9 ¾" x 15 ¼" x 38 ½")

Estimate. £3,000 - 5,000



955
 Zucchabar Arena
 Gladiator Helmet M
Gladiator (2000)

A Zucchabar arena gladiator helmet from Ridley Scott's Oscar®-winning historical epic *Gladiator*. Gladiators wore their helmets and armour in the arena at Zucchabar during Maximus' (Russell Crowe) first fight, and this helmet was worn by a warrior who fought Maximus' ally Hagen (Ralf Moeller). The helmet is made of fibreglass finished in silver paint to replicate metal, with added intentional distressing to create a battle-worn appearance. It features protective cheek and nose guards, and a neck guard is also attached to the back. Pieces of foam padding are adhered to the interior for comfort purposes. There are visible glue remnants, and some foam has come away over time. Dimensions: 33 cm x 16 cm x 29 cm (13" x 6 ¼" x 11 ½")

Estimate. £3,000 - 5,000



956
 General Maximus'
 (Russell Crowe) Roman Greaves M
Gladiator (2000)

General Maximus' (Russell Crowe) Roman greaves from Ridley Scott's historical epic *Gladiator*. Maximus Decimus Meridius wore his greaves when he led the Roman charge in the Battle of Vindobona. These two matching greaves are constructed from fibreglass, painted silver-colour and engraved with Roman designs on the front. Both are padded with leather and feature leather laces tied through metal hooks on the side. The leather is lifting in places from production wear, exposing the fibreglass, and both greaves exhibit intentional scuffing and grime applied by production.

Estimate. £3,000 - 5,000



957
 Maximus' (Russell Crowe)
 Unfinished General Armour M
Gladiator (2000)

Maximus' (Russell Crowe) unfinished general armour from Ridley Scott's Oscar®-winning historical epic *Gladiator*. Maximus wore his armour while leading the Roman legions against the barbarian tribes of Germania during the opening battle. This version of the armour was made for production but is unfinished, and was ultimately not seen in the film. The chest plate is made of fibreglass painted to appear bronze, and is embellished with a silver-coloured wolf's head, two Gryphons and swirling patterns. A pair of leather straps are attached to each side, and there are deliberate holes where the epaulettes were attached. The armour has been intentionally distressed, with slashes to make it appear battle-worn, and the lot comes on a custom-built stand. Dimensions (displayed): 25 cm x 40 cm x 77 cm (9 ¾" x 15 ¾" x 30 ¼")

Estimate. £2,000 - 3,000



959
 Maximus' (Russell Crowe) Encampment Epaulette M
Gladiator (2000)

Maximus' (Russell Crowe) encampment epaulette from Ridley Scott's Oscar®-winning historical epic *Gladiator*. Maximus wore epaulettes on both shoulders when he walked through the Roman encampment after the vicious battle against the barbarians in Germania. The epaulette is made of intentionally weathered leather. It has pointed ends, and the front end is decorated with an ornate button and trim, while a metal loop fastening is attached to the lining at both ends. The lot is presented on a custom-made display. There are remnants of sand and dirt on the leather from filming. Dimensions (displayed): 27.5 cm x 18 cm x 34 cm (10 ¾" x 7" x 13 ¼")

Estimate. £1,000 - 1,500



958
 Maximus' (Russell Crowe) Prototype Face Mask M
Gladiator (2000)

Maximus' (Russell Crowe) prototype face mask from Ridley Scott's Oscar®-winning historical epic *Gladiator*. Maximus wore his mask attached to a helmet during the re-enactment of the famous Battle of Carthage, in which he rallied his desperate team of gladiators against the charioteers. This mask was a prototype and varies slightly from the one seen in the film. Made of fibreglass, the mask is finished in silver-coloured paint with dark grey and black shades applied to produce a weathered, battle-worn appearance. It features large holes, a nose guard and angular detailing at the cheeks. The mask is lined with padded black leather and comes presented on a custom-made display. There are signs of dirt remnants on the leather lining. Dimensions (displayed): 20 cm x 19 cm x 35 cm (8" x 7 ½" x 13 ¾")

Estimate. £1,000 - 1,500



960
 Maximus' (Russell Crowe) Arena Epaulette M
Gladiator (2000)

Maximus' (Russell Crowe) arena epaulette from Ridley Scott's Oscar®-winning historical epic *Gladiator*. Maximus wore epaulettes on both shoulders during the climactic duel against Commodus (Joaquin Phoenix) in the Colosseum. The epaulette comprises five overlapping fibreglass strips, varying in lengths and forming a curved shape. Each strip is black with a silver-coloured outline and decorative rivet detailing, and is lined with black leather. Two metal loop fastenings are attached to the lining at each end of the longest strip. The epaulette is presented on a custom-made display. Dimensions (displayed): 33 cm x 21 cm x 34 cm (13" x 8 ¼" x 13 ¼")

Estimate. £1,000 - 1,500



961
Praetorian
Guard Shield †Δ
Gladiator (2000)

A Praetorian guard shield from Ridley Scott's *Gladiator*. Praetorian guards were the Imperial Roman soldiers tasked with protecting the Emperor, they carried these large shields along with a gladius at their hip or a spear at their side at all times throughout the movie. The shield is wood with a wooden handle and a layer of cotton canvas fabric glued on all sides; copper studs have been affixed to the outer rim, as well as, two steel crescent decals on the top and bottom of the front face. The shield is painted black and features a gold-coloured design of laurels and thunderbolts. It is finished with a vac-formed plastic boss at its centre that shows signs of breakage and repair. Dimensions: 130 cm x 61 cm x 28 cm (51" x 24" x 11") Special shipping required; see special shipping notice in the Buyer's Guide.

Estimate.
£1,000 - 1,500



962
Roman
Legionaries Sword
and Scabbard †Δ
Gladiator (2000)

A Roman legionaries sword and scabbard from Ridley Scott's Oscar®-winning historical epic *Gladiator*. Roman legionaries wielded their swords as they fought the barbarians in the forests of Germania during the film's opening battle, under the command of General Maximus (Russell Crowe). The weapon comprises an aluminium blade, a notched wooden grip, a wooden guard and a spherical wooden pommel. Covered in red canvas fabric, the scabbard is also made of wood and features metal band detailing around the top. Care should be taken when removing the weapon from the scabbard, as it can be difficult to withdraw. Dimensions: 79 cm x 10.5 cm x 6.5 cm (31" x 4 1/4" x 2 1/2")

Estimate.
£1,000 - 1,500



965
Praetorian Standard Ω
Gladiator (2000)

A Praetorian standard from Ridley Scott's historical epic *Gladiator*. The Praetorian guard waved their standard during Emperor Commodus' (Joaquin Phoenix) grand entrance in Rome. Designed by material sourcing company Rangarsons, this purple cotton and canvas standard is emblazoned "Praetoria XIV" above a olive branch garland in gold-colour thread. It features matching gold-colour tassels and comes wrapped with matching gold-colour rope to a wooden staff affixed with a tasselled faux steel spearhead. The head exhibits missing chunks and the staff exhibits nicks throughout from production use. Dimensions: 240 cm x 11.5 cm x 4 cm (94.5" x 4.5" x 1.5") Special shipping required; see notice in the Buyer's Guide.

Estimate. £600 - 800



963
Roman Cavalry
Sword and Sheath Ω
Gladiator (2000)

A Roman cavalry sword and sheath from Ridley Scott's historical epic *Gladiator*. General Maximus Decimus Meridius (Russell Crowe) and the Roman Cavalry wielded their swords in battle against the Germanic tribes. This lot consists of a sword with a lightweight metal blade inset into a brown wooden hilt with a ridged grip and a rounded pommel, as well as a red tape-wrapped wooden sheath with brown leather clip-on straps and a metal guard. The blade exhibits dulling by production, the pommel is slashed, and the tip of the sheath is peeling from use. Dimensions (sheathed): 76.25 cm x 9 cm x 7.75 cm (30" x 3.5" x 3")

Estimate.
£800 - 1,200



964
Roman Infantry
Sword and Sheath Ω
Gladiator (2000)

A Roman infantry sword and sheath from Ridley Scott's historical epic *Gladiator*. The Roman infantry led by General Maximus Decimus Meridius (Russell Crowe) wielded their swords in battle against the Germanic tribes. This lot consists of a sword with a lightweight metal blade inset into a brown wooden hilt with a ridged grip and a rounded pommel, as well as a red tape-wrapped wooden sheath with brown leather clip-on straps and a metal guard. The blade exhibits dulling by production, the pommel is slashed, and the tip of the sheath is peeling from use. Dimensions (sheathed): 76.25 cm x 9 cm x 7.75 cm (30" x 3.5" x 3")

Estimate. £600 - 800

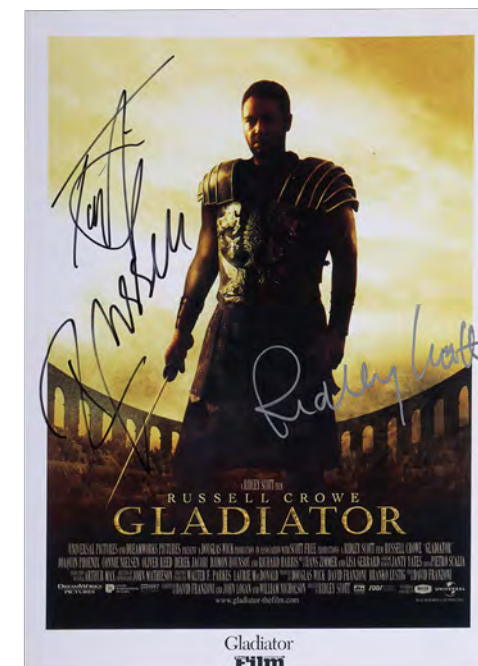

966
Russell Crowe, Ridley
Scott and Tommy Flanagan
Autographed Mini Poster M
Gladiator (2000)

An autographed mini-poster from the promotion of Ridley Scott's Oscar®-winning historical epic *Gladiator*. This poster is a smaller version of the one-sheet design and is printed onto glossy paper. It is autographed in black marker by Russell Crowe (Maximus), Tommy Flanagan (Cicero) and in silver-coloured ink by director Ridley Scott. Dimensions: 41.5 cm x 30 cm (16 1/4" x 11 3/4")

Estimate. £400 - 600



967
Pair of Roman
Praetorian Brooches Ω
Gladiator (2000)

Two Roman Praetorian brooches from Ridley Scott's historical epic *Gladiator*. Members of the Praetorian Guard, the elite soldiers who served as the Roman Emperor Commodus' (Joaquin Phoenix) personal bodyguards, wore distinctive lion-headed brooches. These two resin lion-shaped brooches are painted gold-colour with metal hooks on their backs for attaching to the Praetorian uniform. They exhibit scuffing and paint chipping from production use and age, and the reverses remain unpainted. Dimensions (each): 7.75 cm x 7.75 cm x 4 cm (3" x 3" x 1.5")

Estimate. £300 - 500



968
Michael Corleone's
(Al Pacino) Suit M
Godfather Part III, The (1990)

Michael Corleone's (Al Pacino) suit from Francis Ford Coppola's gangster sequel *The Godfather: Part III*. Michael wore his dark grey single-breasted suit at various points throughout the film, most notably during the negotiations in Vatican City. This custom Italian-made suit comprises a tailored jacket and a pair of trousers, each item featuring "Al Pacino #3" handwritten in black pen on labels sewn into its interior. There are no marked sizes.

Estimate. £3,000 - 5,000



969
Lyra's (Dakota Blue
Richards) Alethiometer Casing †Δ
Golden Compass, The (2007)

Lyra's (Dakota Blue Richards) alethiometer casing from Chris Weitz's fantasy adventure *The Golden Compass*. The alethiometer was a spiritual device used by Lyra to rescue her best friend Roger (Ben Walker) and other kidnapped children from the Gobblers. The prop department created the device's intricately decorated outer shell from forged brass. The lid opens to reveal an image of Prague's Church of Our Lady before Týn. Three faux winding crowns adorn the outside edge, and the inside of the casing is marked "1" in black marker. The lot displays marks and intentional weathering to appear used. Dimensions (closed): 10 cm x 8.5 cm x 3.5 cm (4" x 3 1/2" x 1 1/2")

Estimate. £1,500 - 2,500



970
lorek Stand-in Helmet †Δ
Golden Compass, The (2007)

A lorek stand-in helmet from the production of Chris Weitz's fantasy adventure *The Golden Compass*. lorek Byrnison (voiced by Ian McKellen) was an armoured warrior bear and comrade of Lyra Belacqua (Dakota Blue Richards). This helmet was used on set as a stand-in for actors, as well as a lighting reference for the visual effects artists. It can be seen in some behind-the-scenes footage. The helmet is made of fibreglass and painted to look like hammered and scarred "sky-iron". It differs in design to the digitally created helmet seen in the film, and there is some minor wear to the paintwork in some places. Dimensions: 55 cm x 52 cm x 43 cm (21 3/4" x 20 1/2" x 17")

Estimate. £1,000 - 1,500



971
Simba Head Appliance Ω
Gorillas In The Mist (1988)

A Simba head appliance from Michael Apted's drama *Gorillas in the Mist*. Primatologist Dian Fossey (Sigourney Weaver) infiltrated a band of gorillas in Rwanda and fought for Simba's survival as well as the rest of the pack's. Created by Rick Baker's Cinovation Studios, this appliance consists of black hand-punched hair applied over a black foam latex facial feature with a detailed nose, mouth, brow and cheeks. It is mounted to a display head and glued to a wooden base. The appliance exhibits signs of wear, including a vertical split on the back of the head. Dimensions: 38 cm x 25.5 cm x 30.5 cm (15" x 10" x 12")

Estimate. £800 - 1,200



972
Two Handwritten Letters and an Autographed Book M
Grace Kelly

Two handwritten letters and an autographed book from Grace Kelly. Oscar®-winning actress Kelly was later Princess Grace of Monaco. The two letters - dated "Feb 2nd 1972" and "Jan 20th 1974" - both discuss personal matters, including Kelly accepting the offer of being a godmother, and one is written on "Palais De Monaco" headed paper. The book is "My Book of Flowers", written by Kelly, and it features a personalised inscription on the title page. The lot also consists of a telegram from Kelly to a friend; a Polaroid® of Kelly dancing; and a photo of Kelly presenting an award. Dimensions (book): 28.5 cm x 22 cm x 3 cm (11 1/4" x 8 3/4" x 1 1/4")

Estimate. £300 - 500



200 cm (84")

973
Orb Chamber Wall Panel †Δ
Guardians Of The Galaxy (2014)

An Orb chamber wall panel from James Gunn's superhero movie *Guardians of the Galaxy*. Panels lined the walls of the chamber housing the mysterious Orb, which was stolen by Star-Lord (Chris Pratt) on the planet Morag, and later revealed to house the Power Stone. The chamber was later seen in *Avengers: Endgame* when Rhodey (Don Cheadle) and Nebula (Karen Gillan) travelled to Morag to obtain the Orb before Star-Lord. The piece is made of plaster over a wooden backing board, with large wooden supports to mount the piece on the wall of the set. Telling the story of the creation of the six Infinity Stones, the panel shows the Cosmic Entities forging the stones, with each of the powerful gems picked out in their respective colours - purple, blue, red, green, orange and gold. The panel is finished in blue and faux-gold paint. Dimensions: 200 cm x 214 cm x 15 cm (84 1/4" x 78 3/4" x 6") Special shipping required; see special shipping notice in the Buyer's Guide.

Estimate. £2,000 - 3,000



974
Young Michael Myers's (Daeg Faerch) Clown Costume M
Halloween (2007)

Young Michael Myers' (Daeg Faerch) clown costume from Rob Zombie's horror remake Halloween. As a child obsessed with clowns and masks, Michael Myers wore his clown costume on Halloween, when he killed his older sister Judith (Hanna Hall), her boyfriend Steve (Adam Weisman), and the abusive boyfriend of his mother (William Forsythe). The costume comprises a polyester jumpsuit with a yellow leg, a blue leg, and an upper section featuring a print of a laughing clown. It has elastic on the ankles and ties up at the back of the neck.

Estimate. £3,000 - 5,000

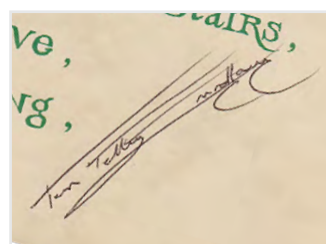
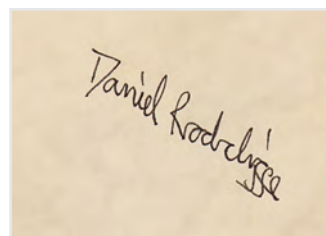
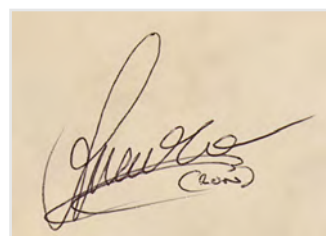
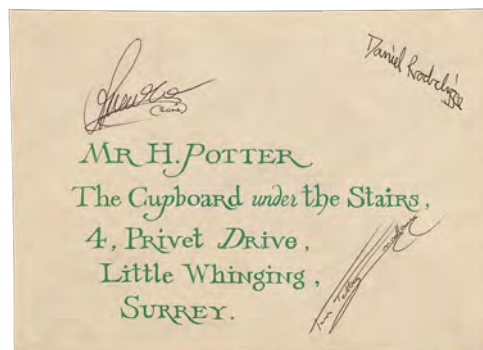

975
Cast-autographed Hogwarts Acceptance Envelope M
Harry Potter And The Philosopher's Stone (2001)

A cast-autographed Hogwarts acceptance envelope from Chris Columbus' fantasy adventure Harry Potter and the Philosopher's Stone. The envelope was created for the scene in which hundreds of acceptance letters flew down the Dursley family's chimney. It has Harry Potter's (Daniel Radcliffe) address printed in green on the front, with a faux wax seal and the Hogwarts crest printed on the back. The envelope is autographed in black pen by Radcliffe, Rupert Grint (Ron Weasley) and Tom Felton (Draco Malfoy). Dimensions: 13.5 cm x 18.5 cm (5 1/4" x 7 1/4")

Estimate. £1,500 - 2,500



976
First Year's Pre-sorting Hogwarts Tie M
Harry Potter And The Philosopher's Stone (2001)

A first year's pre-sorting Hogwarts tie from Chris Columbus' fantasy adventure Harry Potter and the Philosopher's Stone. Pre-sorting ties were worn by the first years from the moment they alighted the Hogwarts Express, to the scene in which they were sorted into their separate houses. This black polyester tie features the Hogwarts emblem and a "Made in Gt. Britain" label. Dimensions: 114.5 cm x 7 cm (45" x 2 3/4") Additional Provenance: Previously sold by Mulberry Bank auction in 2021.

Estimate. £1,200 - 1,800



977
Ollivanders Wand Box M
Harry Potter And The Philosopher's Stone (2001)

An Ollivander's wand box from Chris Columbus' fantasy-adventure film Harry Potter and the Philosopher's Stone. Stacks of boxes filled the shelves of Ollivanders, the shop Harry (Daniel Radcliffe) visited in Diagon Alley to purchase a wand. Boxes were gifted to attendees of the film's world premiere at Leicester Square in 2001. The sealed lid of the cardboard box features a black textured effect and an oval gold-colored Ollivanders-branded label. A small wand-maker measurement sticker is adhered to the left side. There are notable signs of wear to one of the corners on the left edge. Dimensions: 36.25 cm x 8.5 cm x 2.5 cm (14 1/4" x 3 1/4" x 1")

Estimate. £2,000 - 3,000



978
Ollivanders Wand Box M
Harry Potter And The Philosopher's Stone (2001)

An Ollivander's wand box from Chris Columbus' fantasy-adventure film Harry Potter and the Philosopher's Stone. Stacks of boxes filled the shelves of Ollivanders, the shop Harry (Daniel Radcliffe) visited in Diagon Alley to purchase a wand. Boxes were gifted to attendees of the film's world premiere at Leicester Square in 2001. The sealed lid of the cardboard box features a brown textured effect and a goldtone Ollivanders-branded label. A wand-maker measurement sticker is adhered to the left side and has begun to peel at the edges. Dimensions: 36.5 cm x 8.5 cm x 3 cm (14 1/2" x 3 1/2" x 1 1/4")

Estimate. £800 - 1,200

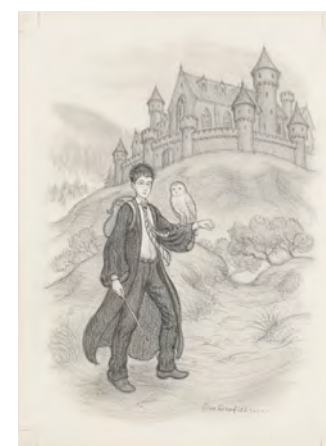

979
Hand-drawn Preliminary Book Cover Illustration by Giles Greenfield M
Harry Potter And The Philosopher's Stone (2001)

A hand-drawn preliminary book cover illustration by Giles Greenfield for the UK and Australian Bloomsbury first edition of J.K. Rowling's Harry Potter and the Goblet of Fire. Greenfield produced multiple compositional and conceptual drawings while creating the book's cover art. This illustration is rendered in pencil on white paper. It depicts Harry Potter standing in his school robes, holding his wand in one hand, with his owl Hedwig resting on his other arm, as Hogwarts School of Witchcraft and Wizardry stands atop a hill behind him. Greenfield has signed the bottom of the artwork in pencil, and the illustration comes presented in a white wooden frame that can be hung via a cord at the back. Dimensions (framed): 58 cm x 47 cm x 2.5 cm (23" x 18 1/2" x 1") Sold without copyright; see copyright notice in the Buyer's Guide.

Estimate. £1,500 - 2,500



980
Daniel Radcliffe and Cast Autographed Call Sheet M
Harry Potter And The Philosopher's Stone (2001)

An autographed call sheet from the production of Chris Columbus' fantasy-adventure film Harry Potter and the Philosopher's Stone. Dated "Friday 17th November 2000", this document is titled "Callsheet: 36" and concerns the external scenes set in the Dark Forest. It features a list of scheduled screen tests and call times for key cast members and doubles, and is autographed in black ink by the film's three stars, Daniel Radcliffe (Harry Potter), Rupert Grint (Ron Weasley) and Emma Watson (Hermione Granger). The sheet displays minor wear along the top edge. Dimensions: 30 cm x 21 cm (11 3/4" x 8 1/4")

Estimate. £800 - 1,200

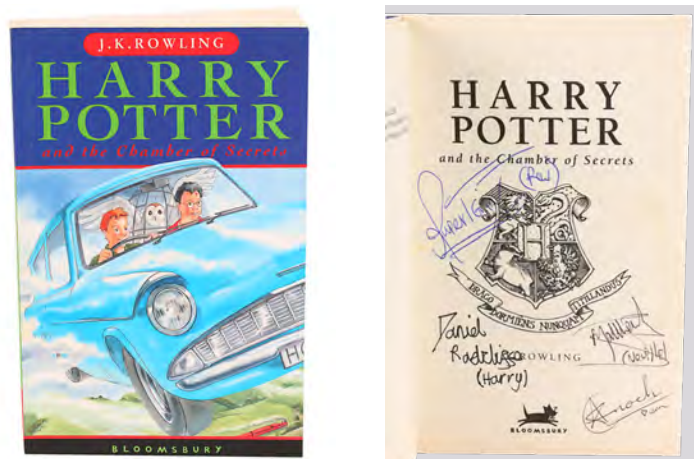

981
Daniel Radcliffe and
Cast-autographed Paperback Book $\pm\Delta$
Harry Potter And The Philosopher's Stone (2001)

A paperback copy of J.K. Rowling's novel Harry Potter and the Chamber of Secrets autographed by four actors from the film adaptation. Published by Bloomsbury, the 32nd print run book features cover artwork of Harry, Ron and Harry's owl Hedwig in the flying car, with an image of Hogwarts School of Witchcraft and Wizardry on the back cover. The title page is autographed in black and blue pen by Daniel Radcliffe, Rupert Grint, Matthew Lewis and Alfred Enoch. The lot exhibits signs of light wear, including minor crease lines on the cover, discolouration around the edges of some pages, and a small yellow stain on the autographed page. Dimensions: 2 cm x 13 cm x 20 cm (3/4" x 5 1/4" x 8")

Estimate. £800 - 1,200



983
Crew Gift Pocket Watch and Coat \mathcal{M}
Harry Potter And The Philosopher's Stone (2001)

A crew gift pocket watch and coat from the production of Chris Columbus' fantasy-adventure film Harry Potter and the Philosopher's Stone. The pocket watch features a curb link chain and an analogue face printed with a lightning bolt and stars. A transparent sticker reading "Harry Potter Cast and Crew 2001" is adhered to the case. The black nylon hooded coat has the Hogwarts crest embroidered on the left breast, and a Golden Snitch emblem decorates the back. The watch comes in a black presentation box, and the coat is labelled size small and displays marks on the lining. Dimensions (watch box): 10.5 cm x 10.5 cm x 3 cm (4 1/4" x 4 1/4" x 1 1/4") Contains mechanical components; see notice in the Buyer's Guide.

Estimate. £1,000 - 1,500



982
Golden Snitch Executive Crew Gift $\pm\Delta$
Harry Potter And The Philosopher's Stone (2001)

A golden snitch executive crew gift from the production of Chris Columbus' fantasy-adventure film Harry Potter and the Philosopher's Stone. The Golden Snitch was the most important ball in the broomstick-based sport known as Quidditch, and replica snitches were gifted to Warner Bros. executives and VIPs to commemorate the film's release. This gold-plated brass snitch features intricate silver-coloured wings and comes in a custom-made wooden box with a black velvet interior and brass clasps. The lot also includes a Warner Bros. certificate of authenticity. Dimensions (snitch): 17 cm x 5 cm x 4 cm (6 3/4" x 2" x 1 1/2"); (box): 13.5 cm x 22 cm x 11 cm (5 1/4" x 8 3/4" x 4 1/4")

Estimate. £2,000 - 3,000



984
Crew Gift Pocket Watch \mathcal{M}
Harry Potter And The Philosopher's Stone (2001)

A crew gift pocket watch from the production of Chris Columbus' fantasy-adventure film Harry Potter and the Philosopher's Stone. Made from gold-plated metal, the pocket watch features a curb link chain and a white analogue face printed with a lightning bolt and stars. A transparent sticker reading "Harry Potter Cast and Crew 2001" is adhered to the top of the case. The watch comes in a black presentation box which also contains a black velvet drawstring bag. Dimensions (watch box): 10.5 cm x 10.5 cm x 3 cm (4 1/4" x 4 1/4" x 1 1/4") Contains mechanical components; see notice in the Buyer's Guide.

Estimate. £1,000 - 1,500



985
Set of Crew Gift Hogwarts
Crests and "Chocolate" Frogs \mathcal{M}
Harry Potter And The Philosopher's Stone (2001)

A set of Hogwarts crests and "chocolate" frogs crew gifts from the production of Chris Columbus' fantasy-adventure film Harry Potter and the Philosopher's Stone. The lot comprises two Hogwarts crests, four shield-shaped house crests featuring each house's emblematic animal, and three frogs. Each piece is made of cast resin with metallic brass, bronze and copper powder finishes applied. All four house crests have felt backing adhered, and the base of the frogs display slight bubbling from the casting process. Dimensions (each house crest): 9.5 cm x 7 cm x 2 cm (3 3/4" x 2 3/4" x 3/4")

Estimate. £600 - 800



987
Daniel Radcliffe-autographed
Portrait Oversized Photo \mathcal{M}
Harry Potter And The Chamber Of Secrets (2002)

An oversized photo autographed by Daniel Radcliffe from the promotion of Chris Columbus' fantasy-adventure sequel Harry Potter and the Chamber of Secrets. The promotional still shows Harry Potter dressed in his red-and-gold Gryffindor Quidditch uniform, holding his Nimbus 2000 broomstick. It has been autographed by Radcliffe in black ink, and there is some surface wear to the top right corner. Dimensions: 40.5 cm x 30.5 cm (16" x 12")

Estimate. £300 - 500



986
SFX Crew Gift \mathcal{M}
Harry Potter And The Chamber Of Secrets (2002)

An SFX crew gift from the production of Chris Columbus' fantasy-adventure sequel Harry Potter and the Chamber of Secrets. Gifted to members of the special effects department, the crew gift shows the Weasley's flying Ford Anglia vehicle perched on top of a tree stump. It is made of fibreglass and resin, finished in brass-coloured paint. A shield featuring "HP II" is located at the front, and situated underneath is a banner that reads "SFX Crew 2002". The gift displays patches of paint wear, notably near the base. Dimensions: 12 cm x 12 cm x 12.5 cm (4 3/4" x 4 3/4" x 5")

Estimate. £400 - 600



988
Set of Three Hand-Illustrated
Doug Brode Dementor Marketing Concept Artworks Ω
Harry Potter And The Prisoner Of Azkaban (2004)

Three Dementor marketing concept sketches hand-drawn by concept artist Doug Brode for Alfonso Cuarón's fantasy sequel Harry Potter and the Prisoner of Azkaban. Warner Bros. incorporated key sequences from the film, including Harry Potter's fight with Dementors, into promotional materials. This set consists of three mixed media illustrations: one of a lone Dementor, one of Harry fighting a Boggart in Dementor form, and one of Harry encircled by Dementors labelled "Inspired from script sc. 117B/pg. 105." all rendered on paper. They exhibit visible creasing, and the labelled sketch is hole-punched. Dimensions (each): 28 cm x 43.25 cm (11" x 17") Sold without copyright; see notice in Buyer's Guide.

Estimate. £1,200 - 1,800

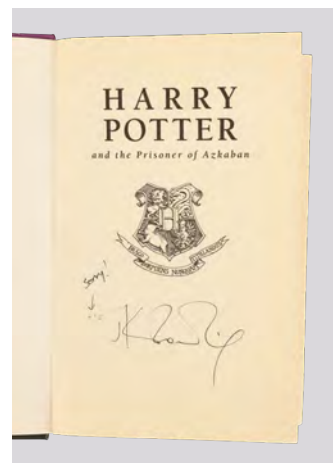
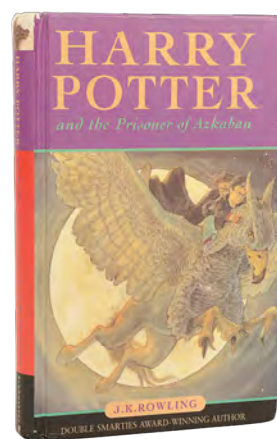

989
J.K. Rowling Autographed Hardback Book †Δ
Harry Potter And The Prisoner Of Azkaban (2004)

A J. K. Rowling-autographed copy of Harry Potter and the Prisoner of Azkaban, the third book in the author's seven-part Harry Potter series. Published by Bloomsbury, this 8th print-run hardback book features cover artwork of Harry and Hermione riding Buckbeak the Hippogriff, with an image of ominous dog-creature the Grim on the reverse. The title page is autographed in black ink by Rowling, who has also written "sorry!" with an arrow pointing to a small hole she made in the page while signing. Random words in the book's text are highlighted, and some pages have been scribbled on with various pens. There is creasing on the edges of the dust jacket. Dimensions: 20.5 cm x 13.5 cm x 2.5 cm (8" x 5 1/4" x 1")

Estimate. £800 - 1,200



991
Quidditch Field Supplies Trunk †
Harry Potter And The Goblet Of Fire (2005)

A Quidditch field supplies trunk from Mike Newell's fantasy sequel Harry Potter and the Goblet of Fire. Trunks were used as set decoration in the Waiting Tent as Harry (Daniel Radcliffe) awaited his turn to battle a dragon, the first task of the Triwizard Tournament. The wicker storage trunk is covered in green-painted canvas with brown leather trim and metal chain detailing. Both sides are decorated with stencilled text, a medical cross logo, and the Hogwarts crest. A rope handle is attached to each end, and the lid secures via two metal clasps. The box exhibits paint wear and warping, and some of the leather has come away. Dimensions: 35 cm x 74 cm x 38 cm (13 3/4" x 29 1/4" x 15")

Estimate. £2,000 - 3,000



990
Set of Four Hand-Drawn
Doug Brode Marketing Concept Sketches Ω
Harry Potter And The Prisoner Of Azkaban (2004)

Four marketing concept sketches hand-drawn by concept artist Doug Brode for Alfonso Cuarón's fantasy sequel Harry Potter and the Prisoner of Azkaban. Warner Bros. incorporated key film sequences into its promotional materials in the run-up to the theatrical release. This set consists of four mixed media illustrations - two of Harry, one of Harry's stag Patronus labelled "The patronus returns to its creator," and one of a Dementor chase labelled "Various monsters/characters in swirl" all rendered on paper. Three sketches are hole-punched, and the set exhibits significant creasing and folded corners throughout. Dimensions (each): 28 cm x 43.25 cm (11" x 17") Sold without copyright; see notice in Buyer's Guide.

Estimate. £800 - 1,200



992
Simon Bamford's Personal Shooting
Scripts, Behind-the-scenes Photos and Ephemera M
Hellraiser (1987) And Hellbound: Hellraiser II (1988)

Simon Bamford's personal shooting scripts, behind-the-scenes photos and ephemera from Clive Barker's horror film Hellraiser and Tony Randel's sequel Hellbound: Hellraiser II. Bamford played "Butterball" in both movies. Both the scripts are autographed by SFX make-up effects artist Cliff Wallace, while the Hellraiser script is also autographed by Doug Bradley (Pinhead), and the "Hellraiser II: Hellbound" script is autographed by Barbie Wilde (Female Cenobite). The Hellraiser script is one of only four copies sent to the original Cenobites. Also included are make-up test Polaroids; 13 stills; a crew T-shirt; assorted paperwork, and a still autographed by Bamford. There are red stage-blood stains on one script and holes in the T-shirt. Dimensions (each script): 30.5 cm x 22 cm x 2 cm (12" x 8 1/2" x 3/4") Sold without copyright; see copyright notice in the Buyer's Guide.

Estimate. £1,000 - 1,500



993
Pillar of
Souls Maquette M
**Hellraiser III: Hell
On Earth (1992)**

A maquette of the Pillar of Souls from Anthony Hickox's horror sequel Hellraiser III: Hell on Earth. The Cenobite Pinhead (Doug Bradley) returns to Earth through the Pillar of Souls, using club owner J.P. Monroe (Kevin Bernhardt) to bring him more victims. Made of cast resin, the model's design features the Cenobite Pinhead, his victims' various anguished figures and faces. Finished in black paint, the maquette displays intentional distressing, and patches of green paint are applied to replicate verdigris patina. Dimensions: 17 cm x 15 cm x 41 cm (6 3/4" x 6" x 16 1/4")

Estimate.
£1,000 - 1,500

995
Pencil Production
Designs for The
Kurgan's Sword †Δ
Highlander (1986)

Pencil production designs for the Kurgan's (Clancy Brown) longsword from the production of Russell Mulcahy's fantasy adventure Highlander. The designs are hand-drawn in pencil on translucent paper that has been layered for rigidity. They feature many handwritten notes about the sword's construction, referencing its retractable guard blades and the unusual hammered look of its pommel. They also include comments about a storage box to be made for transport. The design is rolled and shows minor degradation to the paper. Dimensions (unrolled): 146 cm x 83.5 cm (57 1/2" x 33") Sold without copyright; see notice in the Buyer's Guide.

Estimate.
£2,000 - 3,000



994
Static Puzzlebox M
**Hellraiser:
Revelations (2011)**

A static puzzle box from Victor García's horror sequel Hellraiser: Revelations. The puzzle box - created in the series' mythology by French artisan Philip LeMarchand - started life as a music box, but as LeMarchand delved into the supernatural it became known as the Lament Configuration: a key to unlocking hell itself. The puzzle box is made of solid black-tinted resin, decorated with aluminium plating and sealed with another layer of clear resin. This particular box would have been used for action and wide shots, and has sustained much wear from use on set. The plating has come away on some of its faces and the cube itself is cracked in one corner. Dimensions: 8 cm x 8 cm x 8 cm (3" x 3" x 3")

Estimate.
£2,000 - 3,000

996
Hand-drawn
James Acheson
Connor Macleod
Costume Design M
Highlander (1986)

A hand-drawn Connor Macleod costume design from the production of Russell Mulcahy's fantasy action-adventure Highlander. Hand-illustrated by Academy Award®-winning costume designer James Acheson, this detailed design is rendered in pencil on paper, with the actor and character name written along the top. A list of components are situated underneath, and a tartan fabric swatch is stapled to the lower-left corner. The drawing is signed by Acheson and displays some minor signs of smudging and pinholes. Dimensions: 42 cm x 30 cm (16 1/2" x 11 3/4") Sold without copyright; see copyright notice in the Buyer's Guide.

Estimate.
£2,000 - 3,000

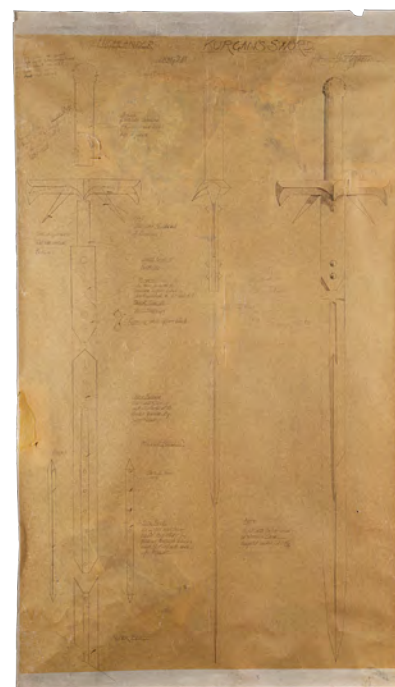

997
Hand-painted James Acheson Ramirez Costume Design M
Highlander (1986)



A hand-painted Ramirez costume design from the production of Russell Mulcahy's fantasy action-adventure Highlander. In the film, Ramirez (Sean Connery) trained Connor MacLeod (Christopher Lambert) to fight their mutual nemesis, The Kurgan (Clancy Brown). Hand-illustrated by Academy Award®-winning costume designer James Acheson, this design is rendered in a combination of watercolours and ink on paper, with the actor's name and production written underneath. It is signed by Acheson in pencil, is labelled "Possible Colour of Costume, 1", and Tippex has been applied to the design in some areas. Dimensions: 29.5 cm x 22.5 cm (11 1/2" x 8 3/4") Sold without copyright; see copyright notice in the Buyer's Guide.

Estimate.
£2,000 - 3,000

998
Hand-drawn James Acheson The Kurgan Costume Design Sketch M
Highlander (1986)



A hand-drawn costume design sketch for The Kurgan from the production of Russell Mulcahy's fantasy action-adventure Highlander. The Kurgan (Clancy Brown) was an immortal barbarian who contended to win The Prize against Scottish immortal Connor MacLeod (Christopher Lambert). Hand-illustrated by Academy Award®-winning costume designer James Acheson, this design is rendered in pencil on paper, with the actor's name and production title written in the top right corner. It features annotations calling out specific components and is signed by Acheson. The left edge of the paper has folded over over time. Dimensions: 42 cm x 30 cm (16 1/2" x 11 3/4") Sold without copyright; see copyright notice in the Buyer's Guide.

Estimate. £400 - 600

1001
Duncan MacLeod's (Adrian Paul) Sword of the Dragon Katana Ω
Highlander (T.V. Series, 1992-1998)



Duncan MacLeod's (Adrian Paul) sword of the Dragon katana from the fantasy-action TV series Highlander. MacLeod was given his iconic dragon-head katana by his mentor, the samurai Hideo Koto (Robert Ito). This sword design was made by Marto Toledo for Season 3. From the end of season 5 and onwards, this sword would feature a bronze collar along the neckline of the dragon-head pommel. The sword's blade is made of 440 stainless steel, and its handle is resin, coloured to resemble carved ivory and featuring Japanese iconography, including its enigmatic dragon-head pommel. The tsuba (guard) is bronze with a motif of two roosters. The sword comes with a black lacquered aluminium scabbard which is missing its Sageo, the cording used to secure the Katana to a belt. Dimensions: 104 cm x 8 cm x 8 cm (41" x 3" x 3")

Estimate.
£1,000 - 1,500



1002
Joe Roberts' (Sean Connery) Army Shorts †
Hill, The (1965)

Joe Roberts' (Sean Connery) army shorts from Sidney Lumet's military prison drama The Hill. Roberts wore his army shorts for most of the film, including the scenes depicting his forced manoeuvres over the eponymous man-made hill. Made of cotton and with a polyester inlay, the shorts are hand-labelled "Sean Connery" by M. Berman Ltd. They are khaki in colour, with a pleated front, slash pockets, an adjustable waist, four belt loops, a stitched hem and a combination button-and-metal-buckle closure. Both buttons exhibit minor fissures.

Estimate.
£1,500 - 2,500



999
Limited Edition David James Print Portfolio Ω
Highlander (1986)

A David James print portfolio from the post-production of Russell Mulcahy's fantasy Highlander. James was the production's still photographer and the photographs comprise number 42 of 500 sets. Each hand-numbered A4 photograph is printed on beige card adhered to an A3 textured card sheet. These black-and-white photos feature Connor MacLeod (Christopher Lambert), the Kurgan (Clancy Brown), Ramirez (Sean Connery) and more. They are presented in their original black card box featuring the text "Highlander - There can be only one" in faux-gold print. The set is accompanied by an official certificate signed by James, dated "Oct 1985" and a letter from Thorn EMI Screen Entertainment. Dimensions (in box): 41.5 cm x 31.5 cm x 2 cm (16 1/4" x 12 1/2" x 3/4")

Estimate. £300 - 500



1000
Geoff Portass' Personal Scripts and Additional Revision Pages M
Highlander (1986) And Highlander II: The Quickening (1991)

Special make-up effects supervisor Geoff Portass' personal scripts and revision pages from Russell Mulcahy's action-adventure fantasy Highlander and its sequel Highlander II: The Quickening. Bound in a black card cover, the 119-page Highlander script is dated "February 6, 1985", and handwritten on the title page is "Geoff Portass- Makeup FX" and "83". Dated "12th October 1989", the Highlander II 103-page document features a red card cover and "20" is written on the title page. Also included is a memo stapled to a set of 31 revision pages for Highlander II. Several annotations and scribbles are present on the torn memo page, which is missing its bottom half. Dimensions (larger script): 28 cm x 22 cm x 1.5 cm (11" x 8 3/4" x 1/2"); (revision pages): 28 cm x 21.5 cm x 0.4 cm (11" x 8 1/2" x 1/4")

Estimate. £600 - 800



88 cm (34")

1003
Iofur's Throne Room Wall Panel M
His Dark Materials (T.V. Series, 2019 - Present)

A wall panel from Iofur Raknison's throne room in His Dark Materials. Iofur ruled the race of armoured bears from his throne room, which was decorated with wall panels. The panel is made of resin, painted to look like bronze, and is displayed with a custom-made wooden frame. The panel is accompanied by a letter of authenticity from the National Film and Television School, who originally sold it in auction. Dimensions: 9.5 cm x 88 cm x 44 cm (3 3/4" x 17 1/4" x 3 3/4")

Estimate. £400 - 600



1004
Dwalin's (Graham McTavish) Prosthetic Dwarf Arms Ω
Hobbit, The: An Unexpected Journey (2012)

Dwalin's (Graham McTavish) prosthetic Dwarf arms from Peter Jackson's fantasy-adventure prequel The Hobbit: An Unexpected Journey. Dwalin travelled with Thorin Oakenshield (Richard Armitage) to reclaim the Lonely Mountain for the Dwarves. Made by Weta Workshop, these two matching silicone prosthetic arms are painted to resemble flesh with hand-punched hair, tattoos, scars, blue-green veins, and white fingernails with vertical ridging. Both arms are affixed with fabric mesh sleeves and mesh undersides for the hands. The arms are intentionally distressed by production to appear grimy from battle and exhibit holes in the fingers and ripped silicone. Dimensions (each): 56 cm x 14 cm x 9 cm (22" x 5.5" x 3.5")

Estimate. £2,000 - 3,000



1005
Set of Three Orc Masks Ω
Hobbit: An Unexpected Journey, The (2012)

Three Orc masks from Peter Jackson's fantasy-adventure prequel The Hobbit: An Unexpected Journey. Orcs, foot soldiers of the Dark Lord Sauron, hunted Bilbo Baggins (Martin Freeman) and his crew of Dwarves. This set consists of three foam latex masks constructed, hand-painted in various earth tones, and pinned to grey cardboard formers for structure by Weta Workshop. Each is hand-punched with small whisker hairs. The masks exhibit nicks in the foam and minor tearing throughout from production wear.

Estimate. £2,000 - 3,000



1007
Set of Production Ephemera Ω
Hocus Pocus (1993)

Ephemera from the production of Kenny Ortega's family fantasy-comedy Hocus Pocus. Originating from a crew member, this set consists of co-producer Bonnie Bruckheimer's black canvas chairback; a blue "Hocus Pocus" crew baseball cap; a printed thank-you note from Kirschner/Haft Productions; colour-printed concept art for the Town Hall scene signed and dated "92" by illustrator Giacomo G. Ghiazza; and 36 black-and-white and full-colour set continuity photographs. The chairback exhibits some residue from production and the concept art exhibits some folded corners. Dimensions (largest): 30.5 cm x 30.5 cm x 15.25 cm (12" x 12" x 6"); (smallest): 10.25 cm x 10.25 cm (4" x 4")

Estimate. £1,000 - 1,500



1006
Sanderson Sisters
Museum Memorabilia with Production Stills Ω
Hocus Pocus (1993)

Sanderson Sisters museum memorabilia with production stills from Kenny Ortega's family fantasy comedy Hocus Pocus. The Sanderson Sisters' (Bette Midler, Sarah Jessica Parker, and Kathy Najimy) home was converted into a museum in Salem. This lot originated with a crew member. It consists of a gold-colour engraved metal plaque for a painting of the "Sanderson Witches" plaque; a wood-framed plaque for Winifred Sanderson's "Spell Book"; a metal S-shaped cauldron hook, and six black-and-white production photographs of the Halloween night sequence. Both the metal plaque and hook exhibit some scratching and scuffing from production. Dimensions: 25.5 cm x 25.5 cm x 18 cm (10" x 10" x 7")

Estimate. £1,500 - 2,500

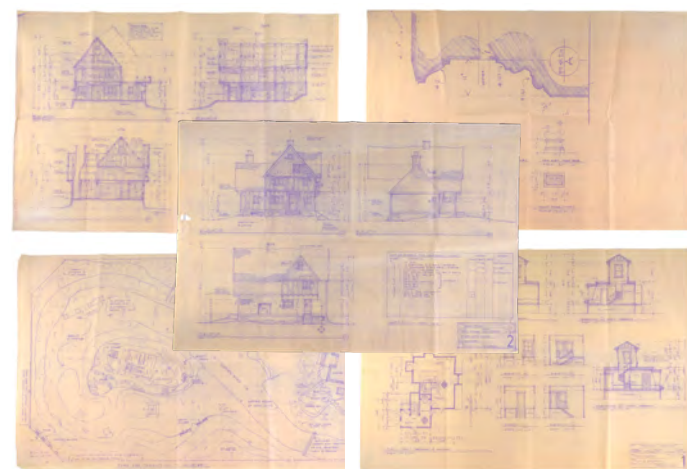

1008
Set of Five Printed Set Blueprints Ω
Hocus Pocus (1993)

Five printed set blueprints from the production of Kenny Ortega's family fantasy-comedy Hocus Pocus. The witchy Sanderson sisters (Bette Midler, Sarah Jessica Parker, and Kathy Najimy) were resurrected on All Hallow's Eve. This lot originated with a crew member. It consists of five production-made blueprint copies labelled for key set pieces, including the Sanderson House, "Max's Bedroom," "Plan 4 Transition to Cemetery," "Witch House," and three animal sculptures. Each is printed on beige draughting paper featuring the production, director, and original draughtsmen's names and date "1992." They exhibit folding, pinholes, small rips, and tearing at the edges from production use and handling. Dimensions (each): 90 cm x 61 cm (35.75" x 24")

Estimate. £600 - 800



1009
Hand-drawn Poster Concept Art Ω
Home Alone 2: Lost In New York (1992)

A poster concept pencil drawing from the promotion of Chris Columbus' adventure-comedy Home Alone 2: Lost in New York. This concept artwork, which was ultimately unused, features Kevin (Macaulay Culkin) on the sidewalk with Harry (Joe Pesci) and Marv (Daniel Stern) peering out of the sewer. It was created by artist Morgan Weistling who has signed the piece. The artwork has a thick paper backing and a tracing paper layer for protection and displays some minor smudging from use. Dimensions: 42.5 cm x 30 cm (16 3/4" x 11 3/4") Sold without copyright; see copyright notice in the Buyer's Guide.

Estimate. £1,200 - 1,800



1010
Newspaper Cover Ω
Home Alone 2: Lost In New York (1992)

A "Wet Bandits Escape" newspaper cover from Chris Columbus' Christmas comedy sequel Home Alone 2: Lost in New York. A torn Chicago Sun-Times newspaper ominously blew onto the McCallister porch the night before Kevin's (Macaulay Culkin) unplanned trip to the Big Apple. The Chicago Sun-Times cover features the headline "Wet Bandits' Escape During Prison Riot," mugshots of the dishevelled Harry (Joe Pesci) and Marv (Daniel Stern), as well as a "Sports Wednesday" section on the reverse. The lot displays some discolouration and a red paint mark on the front. Dimensions: 37.5 cm x 30.5 cm (14.75" x 12")

Estimate. £800 - 1,200



1011
Thud Butt's (Raushan Hammond)
Food Fight Hat and Autographed Photo Ω
Hook (1991)



Thud Butt's (Raushan Hammond) hat from Steven Spielberg's fantasy adventure Hook. After rejoining the Lost Boys, Peter (Robin Williams) inadvertently started a food fight, one of whose participants was Thud Butt. The hat is a blue, green and red tam o' shanter bonnet made from wool with a red pom-pom on top. The hat features remnants of dried icing from the food fight and has been autographed by Hammond on the inside. The hat comes with a certificate of authenticity and an autographed photo of Hammond holding both the certificate and the hat.

Estimate. £2,000 - 3,000



1012
 Pair of Captain Hook's Doubloons Ω
Hook (1991)

Two of Captain Hook's doubloons from Steven Spielberg's fantasy adventure film Hook. Smee (as played by Bob Hoskins) filled his pockets with pirate doubloons from Captain Hook's (as played by Dustin Hoffman) treasure trove. Many of the coins used in Hook also appeared as part of One-Eyed Willy's treasure in The Goonies.

These coins are made of metal hand-painted gold-colour and engraved with cross patterns and bars on opposite sides. Both exhibit scraped paint and exposed metal, and one exhibits glue residue from production. Dimensions (each): 4 cm x 4 cm x 0.75 cm (1.5" x 1.5" x 0.25")

Estimate. £400 - 600

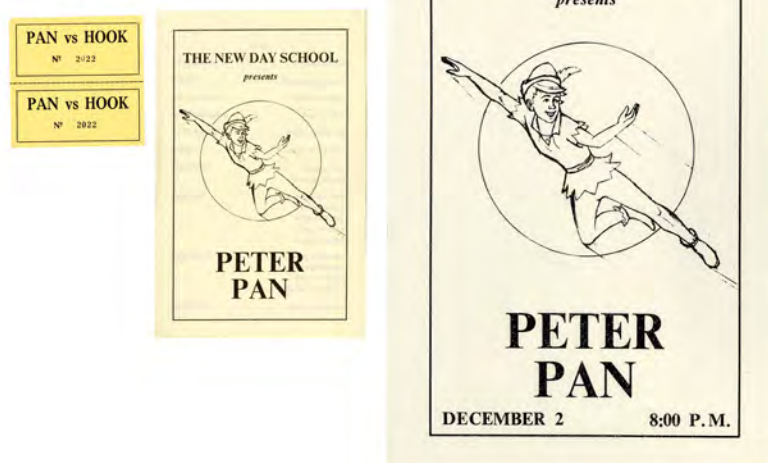

1013
 "Peter Pan" Program, Flyer, and Tickets Ω
Hook (1991)

A "Peter Pan" program, flyer, and tickets from Steven Spielberg's fantasy adventure film Hook. While other parents clutched programs proudly, Peter Banning (as played by Robin Williams) took a call during his daughter's (as played by Amber Scott) school play, and later duelled with Hook (as played by Dustin Hoffman). This lot consists of a two-page paper program for The New Day School's "Peter Pan" with credits on the interior; a matching flyer dated "December 2."; and two production-made yellow tickets labelled "Pan vs Hook No 2022." They exhibit folded corners and fading to the text from age. Dimensions (largest): 28 cm x 43.25 cm (11" x 17"); (smallest): 10.25 cm x 10.25 cm (4" x 4")

Estimate. £600 - 800



1014
 Lost Boys Catapult with Arrows Ω
Hook (1991)

A Lost Boys catapult with arrows from Steven Spielberg's fantasy adventure film Hook. The Lost Boys fired arrows on Peter Banning (as played by Robin Williams) upon his arrival and later used catapults against the pirates. This lot consists of one catapult and two wooden arrows with cloth heads. Constructed of wood, cloth, paper, and tygon tubing, this catapult features faux fur coverings, leather attachments, and a wicker basket. This lot exhibits loose and fragile tygon tubing, and discolouration from production. Dimensions (catapult): 122 cm x 26.75 cm x 100.5 cm (48" x 10.5" x 39.5"); (arrow): 63.5 cm x 6.5 cm x 6.5 cm (25" x 2.5" x 2.5")

Estimate. £2,000 - 3,000

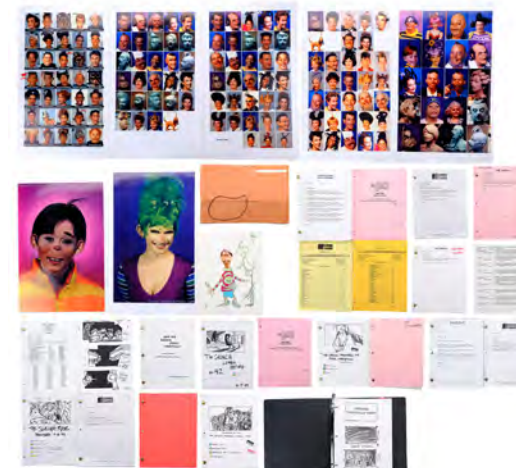

1015
 Whoville Makeup Test Prints
 with Rick Baker's Production Paperwork Ω
How The Grinch Stole Christmas (2000)

Whoville makeup test prints with Rick Baker's production paperwork from Ron Howard's holiday comedy How the Grinch Stole Christmas. Baker and Gail Rowell-Ryan's makeup for the optimistic Whos won them the Academy Award® for Best Makeup. This lot comes directly from Baker. It consists of eight glossy colour Cinovation Studios Whoville makeup test prints; two crew lists; six printed storyboard packets; a story outline; a set of script questions; first and second unit shooting schedules; and six drafts of Jeffrey Price and Peter S. Seaman's screenplay dated between "03/15/99" and "08/11/99." Dimensions: 45.75 cm x 30.5 cm x 30.5 cm (18" x 12" x 12")

Estimate. £800 - 1,200



1017
 Hero and Stunt Time Cartridges, Insert
 Timecodes and Justin Timberlake's Chairback Ω
In Time (2011)

Hero and stunt time cartridges, insert timecodes and Justin Timberlake's chair back from the production of Andrew Niccol's sci-fi action film In Time. Whilst on the run, Will Sales (Justin Timberlake) and Sylvia Weis (Amanda Seyfried) robbed a time bank, giving the extra time cartridges to the needy. This collection comprises two hero metal cartridges, one rubber stunt cartridge, eleven plastic timecodes and a chair back displaying Justin Timberlake's name. One hero cartridge exhibits a dented top edge from production use. Dimensions: (each cartridge) 14.5 cm x 7.5 cm x 2 cm (5 3/4" x 3" x 3/4")

Estimate. £800 - 1,200

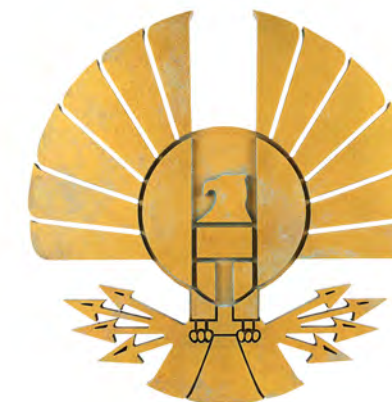

1016
 Decorative Seal of the Capitol Crest Ω
Hunger Games, The (2012)

A decorative crest depicting the official seal of the Capitol from the dystopian sci-fi film series The Hunger Games. Each film contained multifarious representations of the circular crest design displayed on various items, including plinths, flags and screens. Made of wood and painted faux gold, the crest displays an eagle motif. The rear of the crest contains a metal wall hook and several sponge tabs. The paint is slightly worn in certain areas. Dimensions: 47 cm x 46 cm x 2.5 cm (18 1/2" x 18 1/4" x 1")

Estimate. £1,500 - 2,500



1018
 Alien Command Station Model Miniatures Ω
Independence Day (1996)

Alien command station model miniatures from Roland Emmerich's sci-fi action film Independence Day. Captain Steven Hiller (Will Smith) and David Levinson (Jeff Goldblum) saw aliens at computer consoles when they flew into the Harvesters' Mothership to upload a virus. These two ornately detailed blue and green foam command station models are mounted with lights, one blue and one pink, installed to illuminate the alien puppets seated at each station. Both exhibit some exposed foam and have had their lights' wires cut by production, rendering them nonfunctional. Dimensions (each): 51 cm x 45.75 cm x 25.5 cm (10" x 9" x 5") Contains electronics; see notice in the Buyer's Guide.

Estimate. £800 - 1,200



1019
Peruvian Temple Arrow $\Omega\Delta$
Raiders Of The Lost Ark (1981)

A Peruvian temple arrow from Steven Spielberg's action-adventure film Raiders of the Lost Ark. Indiana Jones (Harrison Ford) set off many traps in his rush to escape the crumbling temple after obtaining the idol, including arrows fired out of the walls. This copper-colour arrow features a dense rubber arrowhead for safety with a hollow plastic shaft allowing it to be fired out of an air cannon on set. It exhibits wear from production and age, including paint flaking. Dimensions: 24.25 cm x 2.75 cm x 0.75 cm (9.5" x 1" x 0.25")

Estimate. £3,000 - 5,000

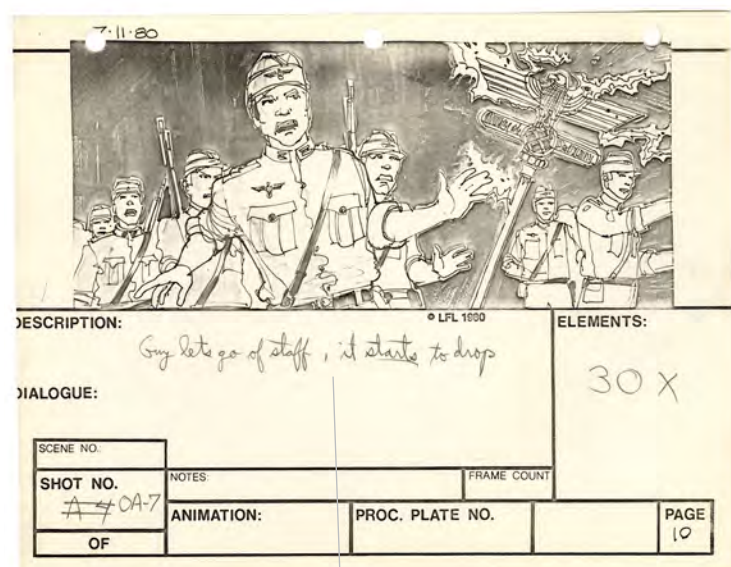

Guy lets go of staff, it starts to drop

1020
VFX Storyboard Hand-Annotated by George Lucas Ω
Raiders Of The Lost Ark (1981)

A VFX storyboard with handwritten annotations by George Lucas from the production of Steven Spielberg's action-adventure Raiders of the Lost Ark. Created by the effects team at Industrial Light & Magic (ILM), this storyboard depicts the scene in which the Ark of the Covenant was opened by the Nazis, releasing ancient spirits. While the storyboard itself is printed, numbered for shot "OA-7" and dated "711.80," it is hand-annotated "Guy lets go of staff, it starts to drop" and "30X," referring to the shot being 30 frames long, in graphite by co-writer/executive producer Lucas. The paper is hole-punched by production and exhibits light fading from age. Dimensions: 28 cm x 21.75 cm (11" x 8.5")

Estimate. £1,000 - 1,500

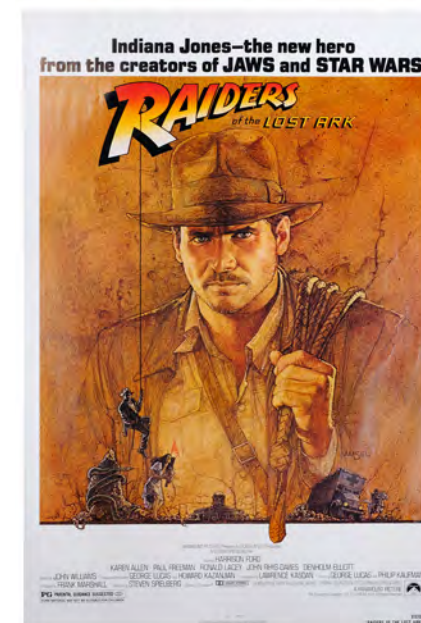

1021
US One-Sheet Ω
Raiders Of The Lost Ark (1981)

A U.S. one-sheet from the promotion of Steven Spielberg's action-adventure Raiders of the Lost Ark. Designed by Richard Amsel, this poster featuring the tagline "Indiana Jones - the new hero from the creators of JAWS and STAR WARS" above an illustration of Indiana Jones (Harrison Ford) with scenes from the film on each side was the first released theatrical poster. This glossy, full-colour one-sheet comes from the collection of executive producer Howard Kazanjian. It also features the National Screen Service (NSS) number "810100" printed in the bottom right corner. The poster exhibits some creasing from being rolled for storage. Dimensions: 68.75 cm x 104.25 cm (27" x 41")

Estimate. £800 - 1,200



1022
Kazim's (Kevork Malikyan) Jacket Ω
Indiana Jones And The Last Crusade (1989)

Kazim's (Kevork Malikyan) jacket from Steven Spielberg's adventure sequel Indiana Jones and the Last Crusade. Kazim wore his jacket during the speed boat chase through Venice. This striped polyester-blend jacket features four front pockets; a sewn-in collar tag with illegible handwriting, and a Bermans & Nathans tag in the inside pocket that displays the actors name "Kevork Malikyan 9329" as well as production information "Kirmal #1" and "Indiana Jones III." It exhibits some light wear from use and age, including loose seams and a single missing front button.

Estimate. £2,500 - 3,500

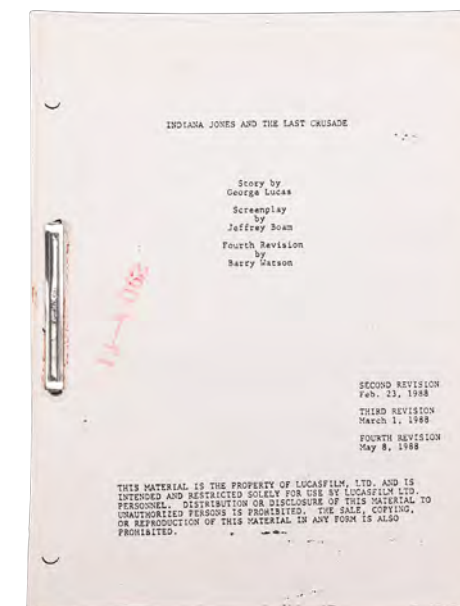

1023
Fourth-revision Script Ω
Indiana Jones And The Last Crusade (1989)

A fourth-revision script from the production of Steven Spielberg's action-adventure sequel Indiana Jones and the Last Crusade. The front cover credits the script to George Lucas, Jeffrey Boam and Barry Watson (a pen name for playwright Tom Stoppard) with a list of revisions dated "Feb. 23, 1988" to "May 8, 1988". Bound by a metal clip, the 147-page script is unannotated, and each page is stamped "IJ-4-062" in red. A large rip is present on the front cover, and corrosion marks are present near the metal clip. Dimensions: 28 cm x 21.5 cm x 2 cm (11" x 8 1/2" x 3/4")

Estimate. £500 - 700



1024
Light-Up Torch Ω
Indiana Jones And The Kingdom Of The Crystal Skull (2008)

A light-up torch from Steven Spielberg's action-adventure sequel Indiana Jones and the Kingdom of the Crystal Skull. Jones (Harrison Ford) and his companions used torches to navigate passageways in the Temple of Akator. The metal and resin torch is finished to resemble cloth and vine-wrapped wooden sticks. It features fibrefill stuffed inside the top, a copper-colour pipe running up through the bottom, and an upper light bulb that illuminates when the cord is plugged in. The torch exhibits paint chipping throughout and bending to the metal filaments near the top. Dimensions: 84 cm x 18 cm x 18 cm (33" x 7" x 7") Contains electronic components; see notice in the Buyer's Guide.

Estimate. £600 - 800



1026
Gadgetmobile's (D.L. Hughley) Eye Headlights Ω
Inspector Gadget (1999)

Gadgetmobile's (D.L. Hughley) eye headlights from David Kellogg's superhero film Inspector Gadget. Dr. Brenda Bradford (Joely Fisher) gave Inspector Gadget (Matthew Broderick) the Gadgetmobile, a robotic automobile with headlights for eyes. These headlights consist of two glass "eyeballs" painted with black irises and affixed with silver-colour plastic lids. Both come mounted to a metal base installed with electronic servos designed to make the lids "blink." The headlights exhibit oxidation on the covers, minor scratching, and visible paint lines from production. They are currently nonfunctional. Dimensions: 40.75 cm x 21.75 cm x 20.5 cm (16" x 8.5" x 8") Contains mechanical components; see notice in the Buyer's Guide.

Estimate. £500 - 700



1025
Will Dormer's (Al Pacino) Pistols and Holsters Ω
Insomnia (2002)

Will Dormer's (Al Pacino) pistols and holsters from Christopher Nolan's thriller Insomnia. Dormer's Smith & Wesson 4505 jammed while chasing Walter Finch (Robin Williams), so he shot him with his Walther PPK/S. This lot consists of one two-toned silver-colour and black rubber Walther PPK/S, one black rubber Smith & Wesson 4505, and two black leather Galco Holster holsters with elastic shoulder straps. These pistols exhibit holes, residue, paint marks, peeling, scratches, and rough edges. Dimensions (each): 23 cm x 15.25 cm x 7 cm (9" x 6" x 2.75") Ownership may be restricted in some countries; see replica firearm notice in Buyer's Guide.

Estimate. £1,500 - 2,500



1027
Louis' (Brad Pitt) Scythe \mathcal{M}
Interview With The Vampire: The Vampire Chronicles (1994)

Louis de Pointe du Lac's (Brad Pitt) scythe from Neil Jordan's gothic horror Interview with the Vampire. Louis used a scythe to cleave Santiago (Stephen Rea) in two, and to slay several enemy vampires, in revenge for the killing of his beloved Claudia (Kirsten Dunst). This one-piece scythe features a pointed blade and a long, angular staff. The blade is made of resin with a ridged metallic chine and a metal bracket at its heel. It is painted black, and has been blunted for safety on set. The staff is made of wood and has a bent snath and a grip handle at its midpoint. A handle previously located at the bottom of the staff is no longer present. The scythe shows signs of wear, including scratches along its snath. Dimensions (staff): 157 cm x 14.5 cm x 7.5 cm (62" x 5 3/4" x 3"); (blade): 56.5 cm x 11 cm x 1.5 cm (22 1/4" x 4 1/2" x 1/2") chair

Estimate. £2,000 - 3,000

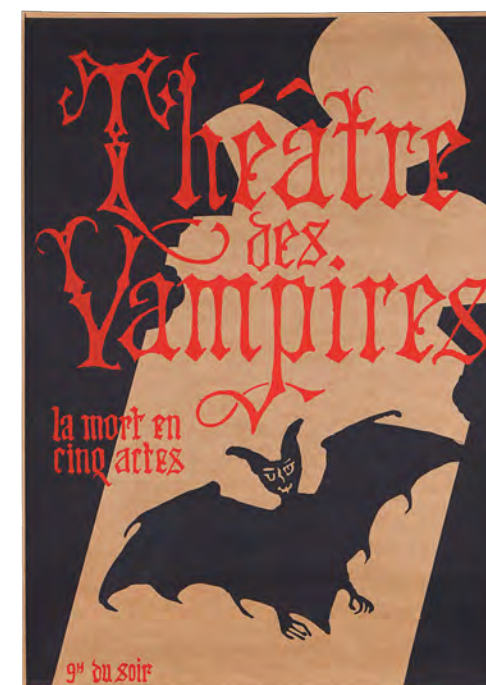

1028
Philip Kohler Collection:
Theatre des Vampires Poster \mathcal{M}
Interview With The Vampire: The Vampire Chronicles (1994)

A Theatre des Vampires poster from Neil Jordan's gothic fantasy Interview with the Vampire: The Vampire Chronicles. Posters for the Theatre des Vampires were displayed outside Armand's (Antonio Banderas) sinister playhouse. This lot comes from the personal collection of renowned production manager Philip Kohler. Printed on heavy brown card, the poster features the words "Theatre des Vampires" above an image of a bat fluttering in a Gothic-style window. The show is billed as "La mort en cinq actes" ("Death in five acts"), and the start time is given as "9 h du soir". There are notable signs of creasing down the right edge. Dimensions: 89.5 cm x 63.5 cm (35 1/4" x 25")

Estimate. £800 - 1,200



1029
Hero Ritual of Chüd Artefact $\dagger\Delta$
It Chapter Two (2019)

A hero Ritual of Chüd artefact from Andy Muschietti's horror sequel It Chapter Two. The Losers tried to use the artefact to contain It during the Ritual of Chüd at the climax of the film. The artefact is made of brown leather sections stitched together with leather string, and has images and patterns engraved upon it. The inside is lined with black fabric. The lid is made of faux clay and features a turtle design. The inside of the opening has adhesive remnants and colour transfer from the lid. 24 cm x 29 cm x 28.5 cm (9 1/2" x 11 1/2" x 11 1/4")

Estimate. £3,000 - 5,000



1030
Scratched Ritual of Chüd Artefact $\dagger\Delta$
It Chapter Two (2019)

A scratched Ritual of Chüd artefact from Andy Muschietti's horror sequel It Chapter Two. The Losers tried to use the artefact to contain It during the Ritual of Chüd, but Mike (Isaiah Mustafa) had scratched off the diagram showing that the previously attempted ritual had failed. The artefact is made of brown leather sections stitched together with leather string, and has images and patterns engraved upon it. The inside is lined with black fabric. One side is intentionally distressed and there are additional scratches on the bottom. The interior of the opening has adhesive remnants. Dimensions: 24 cm x 29 cm x 27 cm (9 1/2" x 11 1/2" x 10 3/4")

Estimate. £2,000 - 3,000



1031
Ritual of Chüd Token Set †
It Chapter Two (2019)

A Ritual of Chüd token set from Andy Muschietti's horror sequel It Chapter Two. The Losers used their tokens – an inhaler, an arcade token, a paper boat, a bloody rock, a yearbook page and a torn postcard – during the ritual to try and capture It. The items have been intentionally distressed to look old and well used, with the rock, postcard and boat all stained with stage blood. Dimensions (rock): 8 cm x 5.5 cm x 3.5 cm (3 1/4" x 2 1/4" x 1 1/2"); (wax boat): 12.5 cm x 26 cm (5" x 10 1/4"); (postcard): 10 cm x 15.5 cm (4" x 6")

Estimate. £2,000 - 3,000

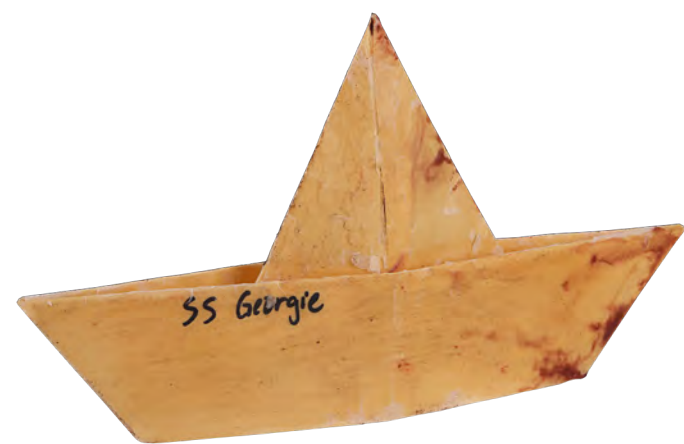

1032
SS Georgie Paper Boat †
It Chapter Two (2019)

An SS Georgie paper boat from Andy Muschietti's horror sequel It Chapter Two. Bill's (James McAvoy) younger brother George (Jackson Robert Scott) perished at the hands of It while playing with his paper boat, the SS Georgie. The boat is made of paper, covered with wax to make it waterproof. It is stained with faux blood and "SS Georgie" is handwritten in black marker on one side. The wax has cracked and come away in some places. Dimensions: 25.5 cm x 13.5 cm (10" x 5 1/4")

Estimate. £800 - 1,200



1035
Stephen King and Cast Chair Backs †
It Chapter Two (2019)

Stephen King's and a cast chair backs from the production of Andy Muschietti's horror sequel It Chapter Two. Author King had a cameo as the pawn shop owner Bill (James McAvoy) buys his old bike from. The chair backs are both black cotton and feature the film's working title of "Largo" on one side. One chair back has King's name printed in white and the other has "Cast". They have been folded for storage. Dimensions (each): 54.5 cm x 18 cm (21 1/2" x 7")

Estimate. £600 - 800



1036
Ben's (Jay Ryan) Hero and SFX Knives †
It Chapter Two (2019)

Ben's (Jay Ryan) hero and SFX knives from Andy Muschietti's horror sequel It Chapter Two. Ben used a knife to stab the monstrous, multi-limbed head of their friend Stan (Wyatt Oleff), who attacked them in the Neibolt House. The hero knife has a metal blade and wooden handle, and has been intentionally distressed and rusted. The SFX knife is made of rubber and has a shortened blade, which has some paint wear. Dimensions (hero knife): 32 cm x 1.5 cm x 3 cm (12 1/2" x 1/2" x 1 1/4"); (SFX knife): 13.5 cm x 1.5 cm x 3 cm (5 1/4" x 1/2" x 1 1/4")

Estimate. £600 - 800



1033
Losers' Screen-
matched Coffee Tin
and Shower Caps †
It Chapter Two (2019)

The Losers' screen-matched coffee tin and shower caps from Andy Muschietti's horror sequel It Chapter Two. Mike (James McAvoy) found the old tin containing his and his friends' shower caps, which they wore as children to stop spiders getting in their hair. The tin matches the one on-screen through creases and markings on the label, which reads "For Use Of Losers Only! - Stan". The tin contains six differently decorated shower caps, three of which correspond to the younger versions of Stan (Wyatt Oleff), Eddie (Jack Dylan Grazer) and Bill (Jaeden Martell). The tin and the caps have all been intentionally distressed and dirtied. Dimensions (tin): 16 cm x 16 cm x 16.5 cm (6 1/4" x 6 1/4" x 6 1/2")

Estimate. £600 - 800



1034
The Daily Derry
Newspaper †
It Chapter Two (2019)

A copy of The Daily Derry newspaper from Andy Muschietti's horror sequel It Chapter Two. The Daily Derry can be seen in newspaper dispensers as the Losers make their way across the town. It features the headline "Body Parts Found In Barrens" and a filler article about a crime in Malaysia. The article underneath (credited to assistant art director David Best) features a synopsis and history of Stanley Kubrick's The Shining. Dimensions (open): 55 cm x 32.5 cm (21 3/4" x 12 3/4")

Estimate. £600 - 800



1037
Bev's (Jessica Chastain) Screen-matched Postcard †
It Chapter Two (2019)

Bev's (Jessica Chastain) screen-matched postcard from Andy Muschietti's horror sequel It Chapter Two. Bev found the postcard – originally written by Ben (Jeremy Ray Taylor) when they were children – in her old apartment. The postcard screen-matches the one in the scene in the way it is torn and has a hair caught under the tape at the top. The postcard has been intentionally distressed with printed blood stains and has been torn roughly into quarters and taped back together. The message from Ben is a haiku, which reads "Your hair is winter fire / January embers / My heart burns there too - Secret Admirer". Dimensions: 10 cm x 16 cm (4" x 6 1/4")

Estimate. £400 - 600

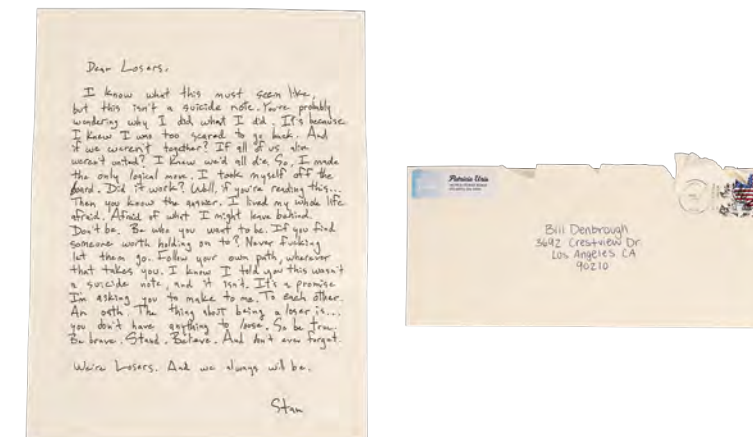

1038
Stan Uris' (Andy Bean) Suicide Letter and Envelope †
It Chapter Two (2019)

Stan Uris' (Andy Bean) suicide letter and envelope from Andy Muschietti's horror sequel It Chapter Two. Stan killed himself rather than face It and sent the Losers letters explaining his actions. Bill (James McAvoy) read his at the end of the film. The letter is printed and folded roughly into thirds. The envelope features Bill's address, a return address, a stamp, and it has been torn open. Dimensions (open letter): 27.5 cm x 21.5 cm (10 3/4" x 8 1/2")

Estimate. £400 - 600



1039
James Stop-motion Puppet Head Display †Δ
James And The Giant Peach (1996)

A James stop-motion puppet head display from Henry Selick's fantasy adventure James and the Giant Peach. James (Paul Terry) transformed into a stop-motion figure when he entered the giant peach, on which he and several friendly insects journeyed to New York City. The film alternated between live-action and stop-motion sequences to reduce production costs. Made of foam latex, the head has brown-painted, dishevelled hair and detailed facial features, including freckles and a pair of black bead-like eyes. Adhered to the neck is a white fabric shirt collar and a painted striped fabric tie. The head comes on a custom peach-shaped display base complete with a metal stalk. Dimensions (displayed): 10 cm x 10 cm x 15 cm (4" x 4" x 6")

Estimate. £800 - 1,200



1041
Peter Nelson Collection:
Stunt and Metal Ninja Weaponry †M
James Bond: You Only Live Twice (1967)

A set of stunt and metal weaponry from Lewis Gilbert's Bond film You Only Live Twice. Four-pointed throwing stars featured in Tiger Tanaka's (Tetsurō Tanba) ninja school, where James Bond (Sean Connery) trained. The lot comprises six four-pointed stunt shuriken (throwing stars), each with a small hole in the middle; two stunt tekko (knuckle dusters); two stunt pommel kunai (throwing knives); a stunt tsuki yari (crescent blade); and two metal pommel tekko-kagi (three-pronged claws). The stunt weapons are made of moulded resin and show signs of wear from production. The stunt shuriken each have small holes in the middle that were created when they were mounted in a museum display case. Dimensions (largest): 19 cm x 14.5 cm x 2 cm (7 1/2" x 14 3/4" x 3/4"); (smallest): 10 cm x 10 cm x 0.5 cm (4" x 4" x 1/4") From the personal collection of Peter Nelson, previously displayed at his two museums, The Cars of the Stars and The Bond Museum in Keswick, Cumbria, until they closed in 2011.

Estimate. £2,000 - 3,000



1040
Set of Autographed Colour
Pictures of James Bond Actors †Δ
James Bond: Various Productions

A set of six autographed pictures of each of the actors who have played James Bond in the Eon series of Bond films. The set comprises autographed colour pictures of Sean Connery, George Lazenby, Roger Moore, Timothy Dalton, Pierce Brosnan and Daniel Craig. In each picture, the actor is shown wearing a tuxedo, and in all but one he is carrying a gun. The pictures are printed on photographic paper. Dimensions (each): 26 cm x 20.5 cm (10 1/2" x 8")

Estimate. £200 - 300



1042
Maurice Binder Archive: Collection of 35mm
opening Title Test, Trailers and Outtakes Footage †M
James Bond: On Her Majesty's Secret Service (1969)

A collection of 35mm footage from the production and promotion of Peter R. Hunt's Bond movie On Her Majesty's Secret Service. These film rolls and trims were used by Maurice Binder to create the trailer, teaser trailer and, most memorably, the opening title sequence. Binder designed the opening titles of 14 James Bond movies, beginning with Dr. No. He was also responsible for producing the iconic gun barrel sequence. Binder designed the opening titles of 14 James Bond movies and was responsible for producing the iconic gun barrel sequence. This set comprises two metal Kodak film cans containing fully spooled reels, with labels detailing the film type, subject and length of the reel. The metal cans exhibit significant rusting from age. Dimensions (one can): 28 cm x 28 cm x 4 cm (11" x 11" x 1 1/2") Sold without copyright; see copyright notice in the Buyer's Guide.

Estimate. £1,500 - 2,500



1043
Maurice Binder Archive: Collection
of 35mm Opening Title Test,
Trailers and Outtake Footage †M
**James Bond: Live And Let Die
(1973)**

A collection of 35mm footage from the production and promotion of Guy Hamilton's Bond movie Live and Let Die. These film rolls and trims were used by Maurice Binder to create the trailer, teaser trailer and the opening title sequence. Binder designed the opening titles of 14 Bond movies, beginning with Dr. No. He was also responsible for producing the iconic gun barrel sequence. The lot comprises three metal film cans, reference tape strips and note pages. Two of the cans each contain a large film roll and the largest can holds 20 rolls. The cans exhibit significant corrosion, but most of the celluloid remains in good condition. Dimensions (largest can): 40 cm x 40 cm x 4.5 cm (15 3/4" x 15 3/4" x 1 3/4") Sold without copyright; see copyright notice in the Buyer's Guide.

Estimate. £1,500 - 2,500



1044
Valerie Leon's Bikini,
Autographed Card and Photo †M
**James Bond:
The Spy Who Loved Me (1977)**

A bikini worn by actor Valerie Leon during the promotion of Lewis Gilbert's Bond film The Spy Who Loved Me. Leon appeared as the hotel receptionist in the Sardinia scenes, and posed for promotional shots wearing this bikini. The bikini is accompanied by a handwritten card by Leon, and the photograph is signed "With love Valerie Leon". The red bikini has wear from age, use and storage, including markings from chlorinated water. It was previously mounted on a display, and the bottoms have stretched, becoming sheer at the back and front. Dimensions (photo): 24 cm x 18.5 cm (9 1/2" x 7 1/4")

Estimate. £600 - 800



1045
Peter Nelson Collection: S.D.
Studios Replica Wrist Dartgun †M
James Bond: Moonraker (1979)

An SD Studios replica wrist dartgun from Lewis Gilbert's Bond film Moonraker. Bond (Roger Moore) used his dartgun to kill the villain Hugo Drax (Michael Lonsdale). S.D. Studios Ltd made this highly-polished aluminium replica. It is accompanied by 10 replica darts. A plaque states the replica is 136 of 5000 (although it is believed that much fewer than 5000 were constructed) and the entire lot is presented in a wooden display case with a combination lock and glass lid. Dimensions (box): 21.5 cm x 31.5 cm x 9.5 cm (8 1/2" x 12 1/2" x 3 3/4") From the personal collection of Peter Nelson, previously displayed at his two museums, "The Cars of the Stars" and "The Bond Museum" in Keswick, Cumbria, until they closed in 2011.

Estimate. £3,000 - 5,000



1046
Peter Nelson Collection: James Bond's (Roger Moore) Knife Thrower Disguise Shirt and Belt M
James Bond: Octopussy (1983)

James Bond's (Roger Moore) Knife Thrower disguise shirt and belt from John Glen's Bond film Octopussy. Bond disguised himself as one of the knife throwing twins, Mischka and Grischka (David and Anthony Meyer), on the Octopussy circus train. The lot includes a red cotton shirt with "Roger" handwritten on the collar label, and a black leather belt with a large metal buckle and studs running up its length. From the personal collection of Peter Nelson, previously displayed at his two museums, "The Cars of the Stars" and "The Bond Museum" in Keswick, Cumbria, until they closed in 2011.

Estimate. £3,000 - 5,000

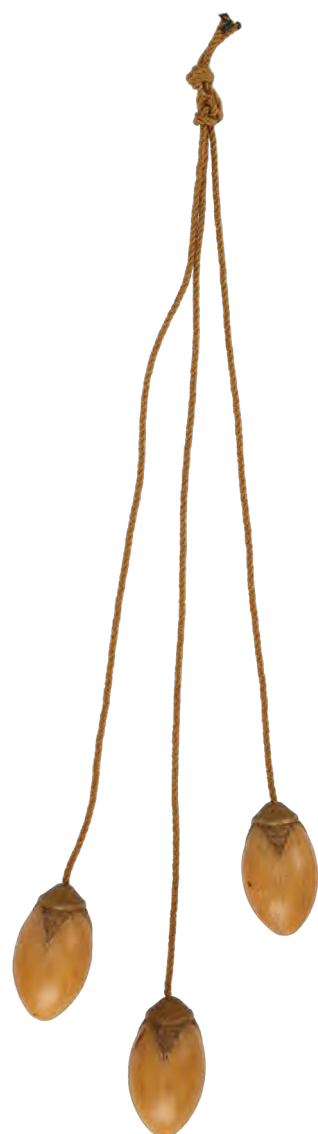

1047
Octopussy's (Maud Adams) Bolas M
James Bond: Octopussy (1983)

Octopussy's (Maud Adams) bolas from John Glen's Bond film Octopussy. Octopussy used her bolas to take down a guard as she and her henchwomen assaulted Kamal Khan's (Louis Jourdan) palace. The bolas are made of resin and are egg-shaped. The top of the bolas are painted to resemble metal and each are attached to a length of gold-coloured rope. They each have some scuffing and wear to the paintwork. Dimensions (each bola) 8 cm x 4.5 cm x 4.5 cm (3 1/4" x 1 3/4" x 1 3/4")

Estimate. £2,000 - 3,000



1048
Octopussy's Circus Sweatshirt T
James Bond: Octopussy (1983)

An Octopussy's Circus sweatshirt from John Glen's Bond movie Octopussy. Members of Octopussy's (Maud Adams) Circus wore their branded sweatshirts when disembarking from the train before their show and boarding the train in East Germany when James Bond (Roger Moore) posed as a circus crew member. The white women's sweatshirt has the circus logo printed on the front and no labelled size. There are slight signs of fading to the logo and minor staining on the sweatshirt.

Estimate. £400 - 600

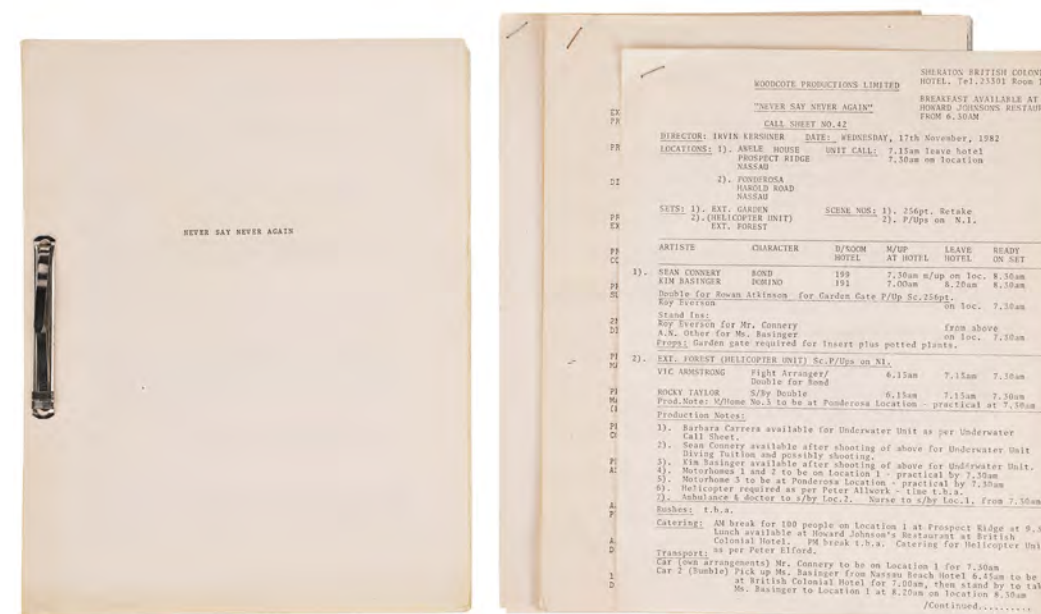

1049
Production-Used Script and Production Paperwork M
James Bond: Never Say Never Again (1983)

A production-used script and production paperwork from Irvin Kershner's 1983 Bond film Never Say Never Again. This set comes from the collection of the late Roy Everson, who worked as Sean Connery's personal assistant and stand-in for many years. The script is 117 pages long and is dated "7.9.82" on each page. It is held together with a metal fastener. Accompanying the script are a unit list, travel information, a Nassau information sheet, and a call sheet. The call sheet lists Everson as both Connery and Rowan Atkinson's stand-ins. The collection also features a handwritten letter of authenticity explaining Everson's personal connection to many film stars. Dimensions (script): 28 cm x 21.5 cm x 1.2 cm (11" x 8 1/2" x 1/2")

Estimate. £400 - 600



1050
Maurice Binder Archive: Collection of 35mm Opening Title Tests, Trailers and Outtake Footage M
James Bond: A View To A Kill (1985)

A unique collection of 35mm footage from the production and promotion of John Glen's Bond movie A View to a Kill. These film rolls and trims were used by film title designer Maurice Binder to create the movie's trailers and, most memorably, the opening title sequence. Binder designed the famous opening titles of 14 James Bond movies, beginning with Dr. No. He was also responsible for producing the iconic gun barrel sequence that has opened most Bond films to date. The collection comprises 24 metal film cans with labels, reference tape strips and some note pages. It includes the final main title sequence, the gun barrel sequence for the trailer, title trims, unused title sections, various scenes from the film, unused FX shots and more. The collection was acquired on the closure of the storage facility for a UK distribution centre in 1998. Most of the celluloid remains in good condition, with a few rolls showing signs of age. Dimensions (largest can): 38 cm x 38 cm x 5 cm (15" x 15" x 2") Sold without copyright; see copyright notice in the Buyer's Guide.

Estimate. £2,000 - 3,000



1051
 Peter Nelson Collection: James Bond's (Roger Moore) Credit Card M
James Bond: A View To A Kill (1985)

James Bond's (Roger Moore) credit card from John Glen's Bond movie A View to a Kill. Bond used his card to unlock a window and gain entrance to Stacey Sutton's (Tanya Roberts) house. Made of plastic, the front of the card is black with gold-coloured lettering, and the rear is black with a white signature strip. The card front features a logo for "The Sharper Image"; the expiry date "11 87"; an embossed 16-digit credit card number across the centre; and "007" in the lower left corner. The rear of the card features Bond's signature, and beneath the signature strip are the words "Authorized Signature" and legal terms. The gold colourant on the card front is slightly abraded. Dimensions: 8.5 cm x 5.5 cm (3 3/4" x 2 1/4") From the personal collection of Peter Nelson, previously displayed at his two museums, "The Cars of the Stars" and "The Bond Museum" in Keswick, Cumbria, until they closed in 2011.

Estimate. £2,000 - 3,000

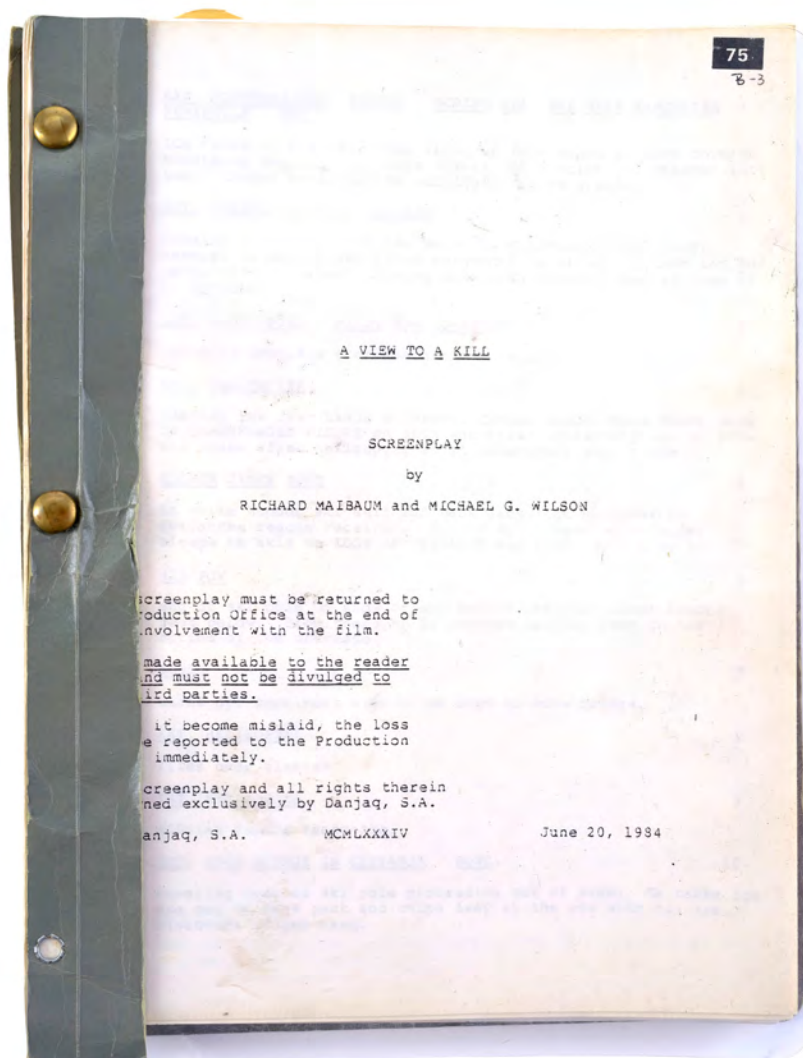

1052
 Bound Annotated Production Script M
James Bond: A View To A Kill (1985)

A bound and annotated production script from John Glen's Bond movie A View to a Kill. The 150-page revised script was written by Richard Maibaum and Michael G. Wilson. This script is bound with brass brads, dated "June 20, 1984," and hand-annotated in ink and graphite throughout its multicolour revision pages. The front cover is numbered "75" and labelled "B-3 by production with tape binding the front and back covers. The script exhibits edge wear throughout and crease lines on the binding. Dimensions: 28 cm x 21.75 cm x 4 cm (11" x 8.5" x 1.5")

Estimate. £600 - 800



1053
 Peter Nelson Collection: Zorin Industries Security Guard Jacket M
James Bond: A View To A Kill (1985)

A security guard jacket from John Glen's Bond movie A View to a Kill. Jackets were worn by security guards at the entrance to Max Zorin's (Christopher Walken) 'Zorin Industries' San Andreas Lake mine. The blue-grey wool jacket features a short collar; button epaulettes; dual chest patch pockets; satin interior lining; and a green-and-white fabric applique patch on each shoulder featuring the Zorin Industries "Z" logo. Included in the lot are two extra "Z" patches, one large and one small. The jacket exhibits minor signs of production wear. From the personal collection of Peter Nelson, previously displayed at his two museums, "The Cars of the Stars" and "The Bond Museum" in Keswick, Cumbria, until they closed in 2011.

Estimate. £600 - 800



1054
 Peter Nelson Collection: Brad Whitaker's (Joe Don Baker) Roman Emperor Statue Head and Photo M
James Bond: The Living Daylights (1987)

A Roman emperor statue head and photo from John Glen's Bond film The Living Daylights. Arms dealer Brad Whitaker (Joe Don Baker) was fascinated with military history and war and had a pantheon of great military commanders at his headquarters, but all the heads were modelled after his. This head is fibreglass with resin eyes and is painted a caucasian skin tone. It sits on a wooden stand to maintain its shape and has some wear from age and use, including a chip to the right ear and some scuffing. It is accompanied by a black-and-white photo of the statue next to Whitaker. Dimensions: 31 cm x 34 cm x 44.5 cm (12 1/4" x 13 1/2" x 17 1/2")

Estimate. £1,000 - 1,500



1055
Peter Nelson Collection:
Trans Siberian Pipeline Jumpsuit **M**
James Bond: The Living Daylights (1987)

A Trans Siberian Pipeline jumpsuit from John Glen's Bond movie *The Living Daylights*. A worker at the Trans Siberian Pipeline plant (Peter Porteus) wore a jumpsuit when he was seduced by his co-worker Rosika Miklos (Julia T. Wallace). Made from blue cotton, the jumpsuit has six press studs running down the front, pleated cuffs and hems, a rear back pocket and a front breast patch pocket. The pipeline logo has been screen-printed onto patches on the back and breast pocket. There is a Bermans & Nathans label located in the collar reading "Pipeline Worker 5250, Living Daylights." There are some stains on the legs of the jumpsuit. From the personal collection of Peter Nelson, previously displayed at his two museums, "The Cars of the Stars" and "The Bond Museum" in Keswick, Cumbria, until they closed in 2011.

Estimate. £600 - 800



1056
Peter Nelson Collection:
Milton Krest (Anthony Zerbe) SFX Head **M**
James Bond: Licence To Kill (1989)

Milton Krest's (Anthony Zerbe) SFX head from John Glen's Bond movie *Licence to Kill*. Krest was killed by drug lord Franz Sanchez (Robert Davi) inside a decompression chamber when Sanchez turned up the pressure valve and then ruptured the vent with an axe. The rapid decompression caused Krest's head to violently explode. Created by special effects supervisor John Richardson based on a mould of Zerbe's face, the head is made of foam latex with an airbrush finish to create a fleshy texture. Hair has been applied to represent eyebrows, eyelashes, a moustache and a receding mane. The addition of ceramic teeth and acrylic eyes gives the head an unsettlingly lifelike appearance. The latex is glued to a wooden base featuring a metal valve, into which air could be pumped to create the effect of Krest's head expanding. There is a small tear in the latex at the bridge of the nose and a 4 cm hole in the wooden base. Dimensions: 41 cm x 47 cm x 21 cm (16" x 18 1/2" x 8 1/2") From the personal collection of Peter Nelson, previously displayed at his two museums, "The Cars of the Stars" and "The Bond Museum" in Keswick, Cumbria, until they closed in 2011.

Estimate. £3,000 - 5,000

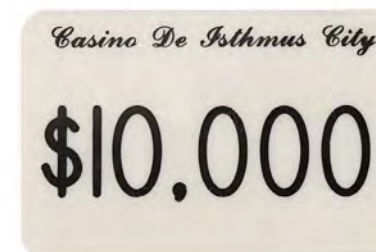

1057
Peter Nelson Collection:
Casino De Isthmus City
Chips & Drinks Stirrer **M**
James Bond: Licence To Kill (1989)

A set of Casino De Isthmus City casino chips and a drink stirrer from John Glen's Bond film *Licence to Kill*. James Bond (Timothy Dalton) posed as a high roller while visiting the Casino De Isthmus City in order to catch the drug baron Sanchez's (Robert Davi) attention. The lot comprises four round poker chips, each coloured purple, grey, green, pink and blue, with its value printed in black at the centre; one rectangular blue chip worth "\$5,000"; one rectangular white chip worth "\$10,000"; and a green drink stirrer which features the casino's name printed in gold inside its circular tip. All the items are made of plastic and exhibit a layer of glue residue on one side from previously being held in a display. Dimensions (largest chip): 7.5 cm x 11.5 cm x 0.5 cm (3" x 4 1/2" x 1/4") From the personal collection of Peter Nelson, previously displayed at his two museums, The Cars of the Stars and The Bond Museum in Keswick, Cumbria, until they closed in 2011.

Estimate. £3,000 - 5,000



1058
Red Cross Medical Supplies Pack **M**
James Bond:
The Living Daylights (1987)

A medical supplies pack from John Glen's Bond film *The Living Daylights*. The Mujahideen, under the leadership of Kamran Shah (Art Malik), transported opium disguised as bags of medical supplies. The hessian fabric pack has "Medical Supplies" printed in black above the red cross medical symbol. The pack is filled with padding and small beads to keep its shape and add weight. Dimensions: 62 cm x 32 cm x 11.5 cm (24 1/2" x 12 1/2" x 4 1/2")

Estimate. £400 - 600



1059
Peter Nelson Collection:
Dario's (Benicio del Toro) Knife **M**
James Bond: Licence To Kill (1989)

Dario's (Benicio del Toro) knife from John Glen's Bond movie *Licence to Kill*. Dario hid his knife in his jacket sleeve and used it to kill people on the orders of drug lord Franz Sanchez (Robert Davi). Among those stabbed by Dario were Felix Leiter's (David Hedison) bride Della Churchill (Priscilla Barnes) and Alvarez (Gerardo Albarrán), the lover of Sanchez's girlfriend, Lupe Lamora (Talisa Soto). The knife has a circular steelommel; a black plastic handle with an ergonomic grip; a steel cross guard; and a fixed steel blade with a spear point. At the base of the blade are the words "BLACK PANTHER SOLINGEN GERMANY", with "#064" on the reverse side. There are several rust spots on the blade. Dimensions: 28 cm x 5 cm x 1 cm (11" x 2" x 1/2") From the personal collection of Peter Nelson, previously displayed at his two museums, "The Cars of the Stars" and "The Bond Museum" in Keswick, Cumbria, until they closed in 2011.

Estimate. £800 - 1,200



1060
 Philip Kohler Collection: Script,
 Storyboards, Photographs and
 Production Paperwork M
James Bond: Licence To Kill (1989)

A script, a set of storyboards, some photographs and a collection of paperwork from the production of John Glen's Bond movie Licence to Kill. This lot comes from the personal collection of renowned production manager Philip Kohler. The lot consists of a 136-page script; additional revised script pages; a set of printed storyboards; 17 black-and-white headshots and stills; five cast-and-crew screening tickets, one of which is autographed by Timothy Dalton; and assorted loose paperwork. All the items feature the initial production title "Licence Revoked", and some of the paperwork features handwritten annotations and notes. Dimensions (script): 29.5 cm x 24 cm x 2 cm (11 1/2" x 9 1/2" x 3/4")

Estimate. £600 - 800

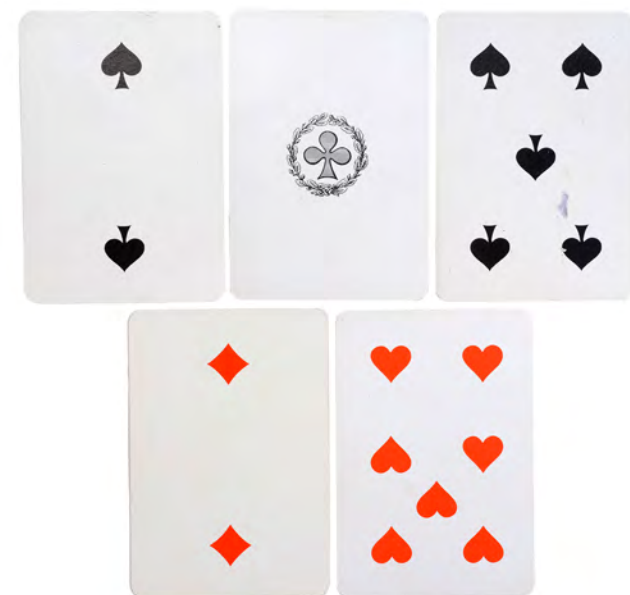

1061
 Set of Five Monte
 Carlo Casino Playing Cards Ω
James Bond: Goldeneye (1995)

Five Monte Carlo Casino playing cards from Martin Campbell's Bond film GoldenEye. After defeating a fellow gambler, Xenia Onatopp (Famke Janssen) played a game of baccarat with James Bond (Pierce Brosnan) at the Monte Carlo Casino. This set of playing cards consists of a 2 of diamonds, a 7 of hearts, a 5 of spades, a 2 of spades, and a club with a drawing of a wreath around it. Each is printed on glossy white cardstock. They exhibit minor edge wear and mild tearing from production. Dimensions (each): 10.25 cm x 7.75 cm (4" x 3")

Estimate. £3,000 - 5,000



1062
 Peter Nelson Collection:
 Six Nerve Gas Barrels M
James Bond: Goldeneye (1995)

Six nerve gas barrels from Martin Campbell's Bond film GoldenEye. Barrels were used as set decoration in the opening scenes as James Bond (Pierce Brosnan) and Alec Trevelyan (Sean Bean) infiltrate a Soviet chemical weapon production facility. The barrels also collapse on top of Soviet soldiers after they attempt to subdue Bond. The set consists of five plastic Mauser® oil canisters and one foam cast one; each has been painted silver with black and red Cyrillic lettering and numbers. The foam barrel shows scorch marks, bullet holes and damage to the top and bottom from use on set. Dimensions (Each) 65.6 cm x 40 cm x 40 cm (25 3/4" x 15 3/4" x 15 3/4") From the personal collection of Peter Nelson, previously displayed at his two museums, "The Cars of the Stars" and "The Bond Museum" in Keswick, Cumbria, until they closed in 2011. Special shipping required: see special shipping notice in the Buyer's Guide.

Estimate. £1,000 - 1,500



1063
 Peter Nelson Collection: Stunt GPS Encoder Box M
James Bond: Tomorrow Never Dies (1997)

A stunt GPS encoder box from Roger Spottiswoode's Bond movie Tomorrow Never Dies. During the opening sequence, terrorist-for-hire Henry Gupta (Ricky Jay) was surveilled purchasing a GPS encoder at an arms bazaar. He later used it at the behest of media mogul Elliot Carver (Jonathan Pryce) to divert HMS Devonshire into Chinese territorial waters and spark a war. The cuboid encoder box is made of metal encased in resin that is painted red. The resin shell features smooth, rounded edges and textured flat panels. The lot exhibits signs of production wear, including flakes to the red paint, and a small section of the hinge barrel is missing. Dimensions: 33 cm x 10 cm x 6 cm (13" x 4" x 2 1/2") From the personal collection of Peter Nelson, previously displayed at his two museums, "The Cars of the Stars" and "The Bond Museum" in Keswick, Cumbria, until they closed in 2011.

Estimate. £2,000 - 3,000



1064
 Philip Kohler Collection:
 Scripts, Production Paperwork and Crew Wear M
James Bond: Tomorrow Never Dies (1997)

A set of scripts, storyboards, paperwork and crew wear from the production of Roger Spottiswoode's Bond movie Tomorrow Never Dies. This lot comes from the personal collection of renowned production manager Philip Kohler. The lot consists of five production-used scripts, three sets of storyboard sequences; three crew T-shirts; two crew jackets; a crew tag; seven production blueprints; 14 individually bound memos, unit lists and shooting schedules. Also included is a binder of deleted scene pages from The World is Not Enough. Two scripts display corrosion marks on their front covers. Dimensions (binder): 35 cm x 29 cm x 7 cm (13 3/4" x 11 1/2" x 2 3/4")

Estimate. £800 - 1,200

1065
 Q's (Desmond Llewelyn) MI6 ID Card M
James Bond: The World Is Not Enough (1999)

Q's (Desmond Llewelyn) MI6 ID card from Michael Apted's Bond film The World is Not Enough. The movie marked Llewelyn's 17th and final appearance in the role. Although not obviously seen on-screen, the ID features a picture of Q and his MI6 information. The card is made of metal, with the information printed on plastic adhered to the ID. It is held in a plastic cover with a metal clip, and has some discolouration and glue remnants. Dimensions: 5 cm x 8.5 cm (2" x 3 1/4")

Estimate. £3,000 - 5,000



1066
 \$10,000 Casino L'or Noir Chip \pm
James Bond: The World Is Not Enough (1999)

A \$10,000 Casino L'or Noir chip from Michael Apted's Bond movie The World Is Not Enough. High-value chips were used by the clientele at Casino L'or Noir, owned by ex-KGB agent Valentin Zukovsky (Robbie Coltrane). Bond (Pierce Brosnan) visited the casino to retrieve information on the Russian terrorist Renard (Robert Carlyle). The silver-coloured plastic chip displays an ornate printed black design that features a side profile image of Zukovsky, card house symbols, the name of the casino, and the chip's denomination. Dimensions: 14 cm x 6.5 cm x 0.5 cm (5 1/2" x 2 1/2" x 1/4")

Estimate. £800 - 1,200



1068
 Philip Kohler Collection: Collection
 of Scripts, Paperwork, Photos and Blueprints \pm
James Bond: The World Is Not Enough (1999)

A collection of scripts, storyboards, paperwork, photos and blueprints from the production of Michael Apted's Bond movie The World is Not Enough. This lot comes from the personal collection of renowned production manager Philip Kohler. The collection comprises four scripts of varying drafts and revisions; a set of script insert pages; two sets of bound printed storyboards; five behind-the-scenes photos of the military base explosion; eight blueprints depicting various designs of the nuclear testing base and vents; a booklet of UK locations, a shooting schedule, a crew memo and 19 unit call sheets. Corrosion marks are present on the metal script clips. Dimensions: (each script) 30 cm x 21 cm x 2 cm (11 3/4" x 8 1/4" x 3/4")

Estimate. £600 - 800



1067
 Philip Kohler Collection:
 Scripts, Blueprints and Production Paperwork \pm
James Bond: The World Is Not Enough (1999)

A collection of scripts, blueprints and production paperwork from Michael Apted's Bond movie The World is Not Enough. This lot comes from the personal collection of renowned production manager Philip Kohler. The lot consists of three scripts (dated "7 October 1998", "12 October 1998" and "29 October 1998"); a file containing a revised script (dated "January 4 1999") and additional revision pages; two sets of paperclipped script-revision pages; seven loose script-revision pages; eight large set-design blueprints; the production's health-and-safety policy; and 11 call sheets. Some of the pages bear Kohler's handwritten name, and the blueprints have been haphazardly folded for storage. Dimensions (each script): 30 cm x 21 cm x 1 cm (11 3/4" x 8 1/4" x 1/2")

Estimate. £600 - 800



1069
 Peter Nelson Collection:
 Nuclear Facility Control Panel \pm
James Bond: The World Is Not Enough (1999)

A nuclear facility control panel from Michael Apted's Bond film The World Is Not Enough. Renard's (Rober Carlyle) henchmen used a control panel while stealing nuclear materials and a bomb. The control panel is made of resin and painted red. It has two control sticks (one labelled "Robot Arm" and one "Lift"), an arrangement of buttons and a screen which reads "Main Operation". A thick black cable protrudes from the right side. It has been intentionally distressed with dirt and has some additional paint wear. Dimensions: 35.5 cm x 19.5 cm x 10 cm (14" x 7 3/4" x 4")

Estimate. £400 - 600



1070
 James Bond's (Pierce Brosnan) MI6 ID Card \pm
James Bond: The World Is Not Enough (1999)
& Die Another Day (2002)

James Bond's (Pierce Brosnan) MI6 ID card from Michael Apted and Lee Tamahori's Bond films The World is Not Enough and Die Another Day. In a deleted scene, Bond used his ID card to open a door as he rushed to try and save Sir Robert King (David Calder) from his explosive money. The ID features a picture of Bond and his MI6 information. The card is made of metal, with the information printed on plastic adhered to the ID. It is held in a plastic cover with a metal clip, and has some discolouration and glue remnants. Dimensions: 5 cm x 8.5 cm (2" x 3 1/4")

Estimate. £3,000 - 5,000



1071
 Moneypenny (Samantha Bond), Q (John Cleese),
 Robinson (Colin Salmon) and Miranda Frost's
 (Rosamund Pike) MI6 ID Cards \pm
James Bond: The World Is Not Enough (1999)
& Die Another Day (2002)

Moneypenny (Samantha Bond), Q (John Cleese), Robinson (Colin Salmon) and Miranda Frost (Rosamund Pike) MI6 ID cards from Michael Apted and Lee Tamahori's Bond films The World is Not Enough and Die Another Day. Although not obviously seen on-screen, the IDs feature a picture of each character and their MI6 information. The cards are made of metal, with the information printed on plastic adhered to the IDs. Each is held in a plastic cover with a metal clip. The IDs have some discolouration and glue remnants, and the back of the Miranda Frost ID has come away. Dimensions (each): 5 cm x 8.5 cm (2" x 3 1/4")

Estimate. £3,000 - 5,000



1072
 M's (Judi Dench) MI6 ID Card \pm
James Bond: The World Is Not Enough (1999)
& Die Another Day (2002)

M's (Judi Dench) MI6 ID card from Michael Apted and Lee Tamahori's Bond films The World is Not Enough and Die Another Day, respectively. Although not seen on-screen, the ID features a picture of M and her MI6 information. The card is made of metal, with the information printed on adhered plastic. It is held in a plastic cover with a metal clip, and the ID has some discolouration and glue remnants. Dimensions: 5 cm x 8.5 cm (2" x 3 1/4")

Estimate. £2,000 - 3,000



1073
James Bond's (Pierce Brosnan)
Stunt Submachine Gun M
James Bond:
Die Another Day (2002)

James Bond's (Pierce Brosnan) stunt sub-machine gun from Lee Tamahori's Bond film Die Another Day. Bond used his sub-machine gun as he tried to escape from a North Korean military base run by Colonel Tan-Sun Moon (Will Yun Lee). This stunt version of an Ingram Military Armament Corp M10 9mm sub-machine gun is made from dense foam rubber. It features such details as an engraved serial number; front and rear sights; a trigger guard; various screw fixtures; a non-moving safety catch; a non-moving pull bolt; a trigger; and an engraved barrel. The gun displays light scratches and chips to the foam rubber. Dimensions: 30 cm x 25.5 cm x 4.5 cm (12" x 10" x 1 3/4") Restricted ownership; see replica firearm notice in the Buyer's Guide.

Estimate. £3,000 - 5,000

1074
Peter Nelson Collection:
Tang Ling Zao's (Rick Yune)
Stunt Jaguar Minigun M
James Bond:
Die Another Day (2002)

Tang Ling Zao's (Rick Yune) stunt Jaguar minigun from Lee Tamahori's Bond film Die Another Day. Bond (Pierce Brosnan) and Zao raced across the frozen Icelandic lakes in their weaponised Aston Martin V12 Vanquish and Jaguar XKR respectively, with Zao's Jaguar armed with a large minigun. This stunt gun is made of resin and painted black. It features four holes in the base where it was screwed to the vehicle. The weapon has some wear to the paint in some areas, exposing the grey resin beneath. Dimensions: 78 cm x 21 cm x 17 cm (30 3/4" x 8 1/4" x 6 3/4") Restricted ownership; see replica firearm notice in the Buyer's Guide.

Estimate. £2,000 - 3,000

1075
Jinx Johnson's
(Halle Berry) Hero Knife M
James Bond: Die Another Day
(2002)

Jinx Johnson's (Halle Berry) hero throwing knife from Lee Tamahori's Bond film Die Another Day. Jinx used her throwing knives while fighting Miranda Frost (Rosamund Pike) during the film's finale, with one knife penetrating a copy of Sun Tzu's book The Art of War. The knife is made of stainless steel with a pointed, double-edged blade that is serrated along half the length of one side. The grip has holes machined into it to give it perfect balance. The words "Stainless" and "Rostfrei" are engraved at the base of the blade. Dimensions: 22 cm x 4 cm x 0.5 cm (8 3/4" x 1 1/2" x 1/4")

Estimate. £1,000 - 1,500



1076
James Bond's (Pierce Brosnan)
Aston Martin Vanquish Action Car Components Ω
James Bond: Die Another Day (2002)

James Bond's (Pierce Brosnan) Aston Martin action car components from Lee Tamahori's Bond film Die Another Day. Bond used his car to smash into the flooded ice palace room to save Jinx (Halle Berry). Made of plastic, this set includes three original Aston Martin pieces from the vehicle and a headlight. Holes are present where spikes assisted the wall breach. The top nose section is split, with a replica Aston Martin logo. It is mounted and has been autographed by 2nd unit director Vic Armstrong, Bond director John Glen and art director Peter Lamont. Also featured is a storyboard page with the icy car chase. Dimensions (display): 120 cm x 46 cm x 32 cm (47" x 18" x 12 1/2")

Estimate. £1,000 - 1,500



1078
Set of Three Ocean Club Chips Ω
James Bond: Casino Royale (2006)

Three Ocean Club chips from Martin Campbell's spy film Casino Royale. Stacks of chips were used for the poker game that James Bond (Daniel Craig) joined at the Bahamas' One & Only Ocean Club. Custom-made for the production, these three plastic poker chips in increments of 5, 25, and 500 dollars feature the Ocean Club Bahamas "One & Only" logo in pink, light green, and light turquoise colours. The set exhibits mild scuffing and discolouration from production. Dimensions (each): 4 cm x 4 cm x 0.75 cm (1.5" x 1.5" x 0.25")

Estimate. £2,000 - 3,000



1077
Philip Kohler Collection: Draft Screenplays,
Storyboards, Production Paperwork and Crew Cap M
James Bond: Die Another Day (2002)

Draft screenplays, storyboards, production paperwork and a crew cap from Lee Tamahori's Bond film Die Another Day. This lot comes from the personal collection of renowned production manager Philip Kohler. The collection comprises two copies of the draft screenplay; a file of UK shooting locations; 48 call sheets; 198 pages of storyboards; movement orders; production memos; printed maps of Iceland; reprinted ice palace set-design blueprints; Eon letter-headed paper; a location budget breakdown; a script breakdown; shooting schedules; a Christmas card; and a navy blue polyester crew cap. Dimensions (script folder): 32 cm x 28.5 cm x 5 cm (12 1/2" x 11 1/4" x 2"); (call sheets): 29.5 cm x 21 cm (11 1/2" x 8 1/4")

Estimate. £800 - 1,200



1079
Set of Four Newspapers †Δ
James Bond: Casino Royale (2006)

A set of four newspapers from Martin Campbell's Bond movie Casino Royale. M (Judi Dench) threw a copy of the Evening Standard onto her table after being startled by Bond (Daniel Craig) when he broke into her home. The other production made newspapers were ultimately not seen in the final cut of the film. The lot comprises a copy of the Evening Standard, The Independent, The Daily Telegraph and the International Herald Tribune, all dated Friday 7 July 2006. Each front cover features headlines and CCTV images relating to Bond's assassination of Mollaka (Sébastien Foucan). Interior filler pages are present within The Independent, and some of the newspapers exhibit small tears along some edges. Dimensions (largest newspaper): 60 cm x 37 cm (23 1/2" x 14 1/2")

Estimate. £800 - 1,200



1080
 Game 2 Set Deck
 of "One&Only" Cards †Δ
James Bond: Casino Royale (2006)

A deck of "One&Only" playing cards from Martin Campbell's Bond movie Casino Royale. Packs of playing cards were used in the "One&Only" Ocean Club in the Bahamas, where Bond (Daniel Craig) met Alex Dimitrios (Simon Abkarian) during a poker game. Custom-made by Cartamundi, the high quality stock cards are each branded "OO", with blue-patterned backing. "Set Deck, Game 2" is written in gold ink on the packaging, denoting the scene they were used for. The packaging displays some signs of wear from being opened and a small tear on the right side. Dimensions: 9.5 cm x 6.5 cm x 2 cm (3 ¾" x 2 ¾" x ¾")

Estimate. £600 - 800

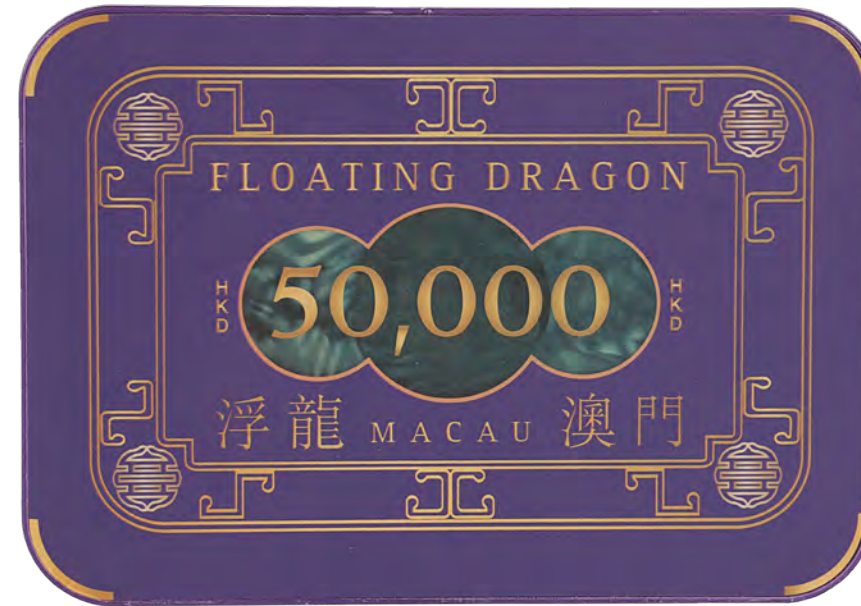

1082
 Floating Dragon
 HKD50,000 Casino Plaque †Δ
James Bond: Skyfall (2012)

A Floating Dragon casino plaque from Sam Mendes' Bond film Skyfall. Casino chips were used in the floating casino in Macau Bond (Daniel Craig) visited as he sought information about assassin Patrice (Ola Rapace). The purple plastic chip features emerald and golden detailing and "Floating Dragon" and "Macau" on both sides. Dimensions: 7.5 cm x 11 cm x 0.5 cm (3" x 4 ½" x ¼")

Estimate. £2,000 - 3,000



1081
 Floating Dragon
 HKD10,000 Casino Plaque †Δ
James Bond: Skyfall (2012)

A Floating Dragon casino plaque from Sam Mendes' Bond film Skyfall. Casino chips were used in the floating casino in Macau Bond (Daniel Craig) visited as he sought information about assassin Patrice (Ola Rapace). The burgundy plastic chip features emerald and golden detailing and "Floating Dragon" and "Macau" on both sides. Dimensions: 7.5 cm x 11 cm x 0.5 cm (3" x 4 ½" x ¼")

Estimate. £2,000 - 3,000

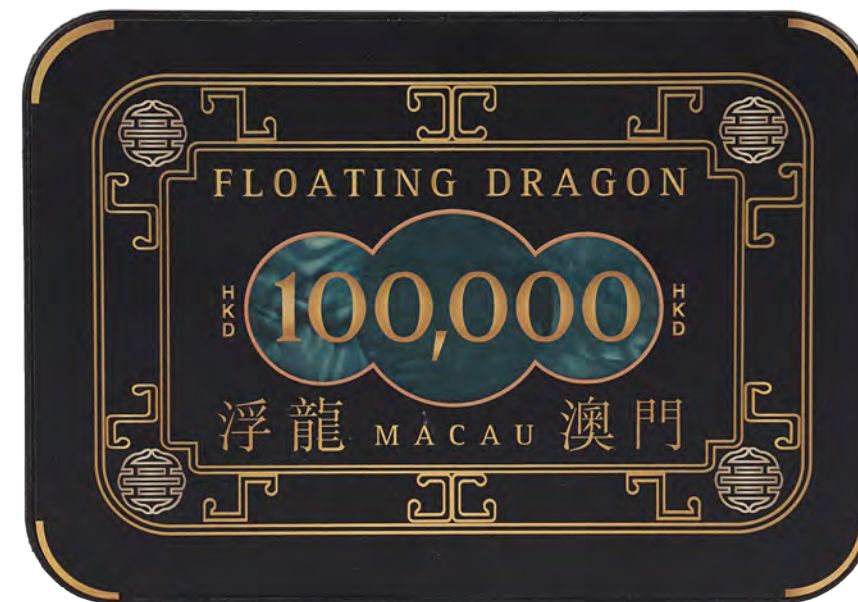

1083
 Floating Dragon
 HKD100,000 Casino Plaque †Δ
James Bond: Skyfall (2012)

A Floating Dragon casino plaque from Sam Mendes' Bond film Skyfall. Casino chips were used in the floating casino in Macau Bond (Daniel Craig) visited as he sought information about assassin Patrice (Ola Rapace). The black plastic chip features emerald and golden detailing and "Floating Dragon" and "Macau" on both sides. Dimensions: 7.5 cm x 11 cm x 0.5 cm (3" x 4 ½" x ¼")

Estimate. £2,000 - 3,000

Day 4

Lots 1084 - 1536.
Nov 6, 2022



1084
Production Clapperboard M
Jaws 3 (1983)

A production clapperboard from Joe Alves shark-infested thriller Jaws 3-D. Clapperboards were used to signal the beginning and ending of a shot to the cast, crew and production team; they also aided in organising takes for the post-production team. The clapperboard comprises a translucent acrylic board featuring the film's title; a section for scene, take, lens, "convg", T-stop, effects; the Director's and Camera Operator J. Contner's names; the date "[missing]-14-83" and "A Camera" beneath it. Along the top of the board is a wooden clapper featuring a metal hinge, the traditional black and white striped paint and a magnet to ensure a firm snap when the clapper is closed. Dimensions: 40.5 cm x 27 cm x 2 cm (16" x 10½" x ¾")

Estimate. £2,000 - 3,000



1085
Bruce Shark Maquette Ω
Jaws Ride At
Universal Studios Florida

A Bruce shark maquette from the creation of the Jaws ride at the Universal Studios Florida in Orlando, Florida. The attraction, which ran from 1990 until 2012, featured animatronic recreations of the famous shark (nicknamed "Bruce") from Steven Spielberg's 1975 thriller film Jaws, which were designed using detailed maquettes. This maquette, depicting a great white shark, is made of biscuit foam painted grey and white with black eyes and a pink mouth mounted to a wooden base. The foam exhibits cracking throughout, missing teeth, and signs of repair, including a reattached fin. Dimensions: 58.5 cm x 29.25 cm x 19.25 cm (23" x 11.5" x 7.5")

Estimate. £800 - 1,200



1086
The Creeper's (Jonathan Breck)
Hero Distressed T-Shirt M
Jeepers Creepers 2 (2003)

The Creeper's (Jonathan Breck) hero distressed T-shirt from Victor Salva's horror sequel Jeepers Creepers 2. The Creeper wore his T-shirt as he terrorised a bus full of students. The brown T-shirt is intentionally distressed, with holes, tears and staining. It is accompanied by a black undershirt onto which The Creeper's prosthetic chest is adhered. Both shirts have metal fasteners at the back so they can be easily worn and removed.

Estimate. £3,000 - 5,000



*Certain films and shows have Lots offered on more than one day of the Auction; see Index on page 681 for a complete listing of available Lots by film or show title



1087
Set of Turbo Man and Dementor Memorabilia
Jingle All The Way (1996)

Turbo Man and Dementor memorabilia from Brian Levant's Christmas comedy Jingle All The Way. Jamie Langston (Jake Lloyd) obsessed over Turbo Man's cereal and comic books, but only Dementor toys were available when his father Howard (Arnold Schwarzenegger) went Christmas shopping. This set consists of a production-made glossy "Turbo Man Special 1st Issue" comic book; an unfolded cardboard Turbo Man cereal box; two Turbo Man action figure cardbacks; a Dementor cardback; and a Dementor action figure in a plastic bubble. The cardboard components exhibit bent corners from production. Dimensions (largest): 39.5 cm x 52 cm (15.5" x 20.5"); (smallest): 18 cm x 25.5 cm (7" x 10")

Estimate. £1,000 - 1,500



1088
Arnold Schwarzenegger Signed Letter, Karate Box,
Gift Certificate, Newspaper and Costume Designs
Jingle All The Way (1996)

A letter, karate box, newspaper, set of costume designs and production items from Brian Levant's Christmas comedy Jingle All The Way. Howard Langston (Arnold Schwarzenegger) signed a letter while running late for his son Jamie's (Jake Lloyd) karate presentation, and a family photo is seen on his desk. The lot comprises a printed Langston company letter signed by Schwarzenegger - as himself, rather than his character - in black ink; a balsa wooden karate box; a Star Tribune newspaper; a production-made green Turbo Man gift certificate; a "Booster" sticker; a printed photo of the Langston family; a laminated production-title sign; and 12 printed costume designs for Turbo Man and his nemesis Dementor. Dimensions (box): 35.5 cm x 16 cm x 11 cm (14" x 6 1/4" x 4 1/4")

Estimate. £600 - 800



1089
Three Cans
of Jump Soda
**Joe Versus The
Volcano (1990)**

Three cans of Jump Soda from John Patrick Shanley's fantasy romance Joe Versus the Volcano. Residents of Waponi Woo drank their beloved Jump Soda throughout the film. This lot consists of three detailed, matching aluminium quart-size cans designed to resemble a real-world soda product with the "Jump" logo, ingredients, and other information printed around it. The cans are topless and exhibit visible rusting, stains, and dents from production use and age. Dimensions (each): 9 cm x 9 cm x 19 cm (3.5" x 3.5" x 7.5")

**Estimate.
£1,000 - 1,500**



1090
John Wick
(Keanu Reeves) Stunt
Horse Chase Suit
**John Wick: Chapter 3
- Parabellum (2019)**

John Wick (Keanu Reeves) stunt suit from Chad Stahelski's John Wick: Chapter 3 - Parabellum. John Wick wore his iconic suits throughout the franchise, and wore this particular ensemble when he had been wounded and chased through a horse stable by assassins, which lead to an epic horse-vs-motorcycle chase through the streets of New York City. The intentionally distressed costume consists of a dark grey polyester blazer and trousers (42W 36R) with plastic buttons and handwritten labels that read "Richard"; a grey pin-striped silk tie; a white polyester blend shirt (size 34/35) that has been hemmed in along the back and features red paint on the right hand side to resemble blood; a reversible black leather belt with a metal buckle; and a pair of black leather Calvin Klein® dress shoes (US 10) with rubber heels.

**Estimate.
£2,000 - 3,000**



1091
Captain Klenzendorf (Sam Rockwell) Nazi Uniform
Jojo Rabbit (2019)

Captain Klenzendorf's (Sam Rockwell) Nazi uniform from Taika Waititi's World War II comedy-drama Jojo Rabbit. Klenzendorf wore his uniform throughout the film. The costume consists of a green woollen jacket, a white shirt (labelled size "M 40") and a pair of grey trousers. The jacket is decorated with epaulettes, patches, badges and insignia indicating Klenzendorf's rank and battlefield accolades, including a breast eagle, a wound badge and an Iron Cross. The shirt and trousers contain Hero Collection costumier's labels, and the jacket and trousers each have "Klenzendorf" handwritten on a label inside.

Estimate. £2,000 - 3,000



1092
Jurassic Park Vehicle Decal
Jurassic Park: The Ride (1996 - 2018)

A vehicle decal from Universal Studios' amusement ride Jurassic Park: The Ride. Vehicle decals of this style were originally made for the production of Steven Spielberg's Jurassic Park, then reused to dress the boats on the water-based rollercoaster. This decal features the classic red, white, and black T-Rex "Jurassic Park" logo on the front with a black and white backing. It remains unpeeled and exhibits minor folding and creasing from storage. Dimensions: 51.5 cm x 55 cm (20.25" x 26")

Estimate. £500 - 700



1093
Production-Made Mr. DNA Animation Cel
Jurassic Park (1993)

A Mr. DNA animation cell from the production of Steven Spielberg's adventure sci-fi film Jurassic Park. Mr. DNA, voiced by Greg Burson, is introduced to Grant (Sam Neill), Ellie (Laura Dern) and Malcolm (Jeff Goldblum) by Hammond (Richard Attenborough) through the medium of animation; in a whimsical manner, Mr. DNA explains the wonders of Hammond's research and how he managed to bring dinosaurs back from extinction. The animation cel, short for celluloid which is a transparent sheet of plastic, features the colourful Mr. DNA hanging from a string above his head; in the sequence, this string is pulled to change the scene, however, a slightly different version to this particular cel was used in the final cut of the film. He is painted using gauche, features the number "31" handwritten in the bottom right corner and has been lovingly displayed to preserve the artwork. Dimensions: (Framed) 45.5 cm x 40.5 cm x 3 cm (18" x 16" x 1")

Estimate. £1,000 - 1,500

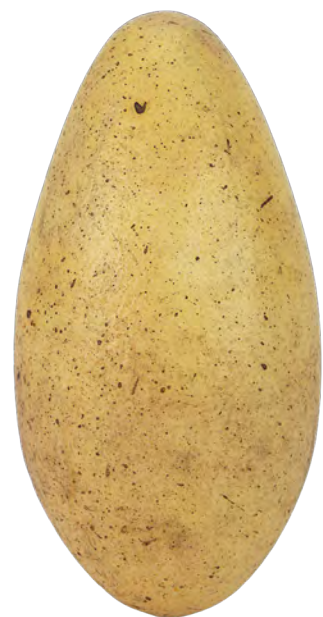

1094
Raptor Egg M
Jurassic Park III (2001)

A Raptor egg from Joe Johnston's sci-fi action sequel Jurassic Park III. Billy (Alessandro Nivola) stole two raptor eggs from their nest during the group's search for lost boy Eric (Trevor Morgan). The egg is made of foam rubber and features brown paint speckles. It exhibits faint dirt marks from production use. Dimensions: 15 cm x 7.5 cm x 7.5 cm (6" x 3" x 3")

Estimate. £3,000 - 5,000



1095
Weathered Jurassic Park Rain Jacket Ω
Jurassic World (2015)

A weathered Jurassic Park rain jacket from Colin Trevorrow's action-adventure sequel Jurassic World. Jurassic Park rain jackets were seen hanging on the wall in a storage room within the ruins of the original dinosaur park's Visitor Centre. This rain jacket is manufactured by Western Safety and features stickers displaying the classic Jurassic Park logo on the back and left breast. As these jackets were intended for set decoration, stickers were used instead of printing the logo directly onto the coat. The garment comes with its detachable hood and has been heavily distressed for the film, with staining and dirt applied.

Estimate. £3,000 - 5,000



1096
Park Visitor Brochure and Waterproof Park Jacket ⚠
Jurassic World (2015)

A park visitor brochure and production-made waterproof jacket from Colin Trevorrow's action-adventure sequel Jurassic World. Brochures were seen being read and carried by visitors to the dinosaur theme park at various points throughout the film. The jacket was made for the production, but this style was ultimately not seen in the film's final cut. The brochure features the park's logo with its name printed in five different languages on the cover. Inside are the various rides and attractions, with a detailed map of the island. Marked size XL, the blue Sport-Tek® waterproof jacket has the production title and a Chinese-style dragon head emblem printed in white on the left breast. Marks are present on the front of the coat. Dimensions (brochure folded): 22 cm x 9.5 cm (8 1/2" x 3 3/4")

Estimate. £2,000 - 3,000



1097
Dinosaur Egg Ω
Jurassic World (2015)

A dinosaur egg from Colin Trevorrow's action-adventure sequel Jurassic World. Dinosaur eggs incubated in the lab area when dinosaur safari park operations manager Claire Dearing (Bryce Dallas Howard) gave a speech about the state of the park. This oval-shaped resin egg is based on the size and shape of an ostrich egg. It features a textured surface hand-painted eggshell-colour with brown speckling, as well as a small production-made hole on the bottom. It exhibits paint splotching and a ring of black grime around its circumference from production. Dimensions: 14 cm x 11.5 cm x 11.5 cm (5.5" x 4.5" x 4.5")

Estimate. £1,200 - 1,800



1099
Press Junket Backdrop Sign M
Jurassic World: Fallen Kingdom (2018)

A backdrop sign from the promotion of J.A. Bayona's Jurassic World: Fallen Kingdom. This sign was used to decorate the backdrop during a press junket where the cast were interviewed by various press associations. The sign is thick rigid foam board shaped and carved to look like cracked stone and painted a weathered grey. It features the iconic skeletal Tyrannosaurus Rex above the name "Jurassic World". It shows minor paint wear to the corners and sharp edges and has a hole at the top where it was affixed to a wall. Dimensions: 123 cm x 63 cm x 5 cm (48 1/2" x 24 3/4" x 2")

Estimate. £600 - 800



1098
Isla Nublar Licence Plate Ω
Jurassic World (2015)

An Isla Nublar licence plate from Colin Trevorrow's action-adventure sequel Jurassic World. Staff vehicles at Jurassic World carried licence plates labelled for Isla Nublar. This plastic plate is numbered "J029" and painted blue and white with the Jurassic Park logo at centre and "Jurassic World" and "Isla Nublar" on the top and bottom edges, respectively. It features two production-made holes on top for mounting to a vehicle. The plate exhibits sticky residue, grime, and scuffing from production use with its reverse unpainted. Dimensions: 30.5 cm x 15.25 cm x 0.75 cm (12" x 6" x 0.25")

Estimate. £1,200 - 1,800



1100
Referee T-Shirt M
Karate Kid, The (1983)

An official's T-shirt from John G. Avildsen's action drama The Karate Kid. Official's wore their T-shirts during the All Valley Karate Championship tournament where Daniel (Ralph Macchio) has his final face off against Johnny (William Zabka) and the rest of the Cobra Kai. The T-shirt (size S34-36) is dark-blue cotton featuring "All Valley Karate Championship" printed on the back with an orange and red design and "Official" printed on the front in white.

Estimate. £800 - 1,200



1101
James Kavanagh QC's (John Thaw) Director's Chair, Briefcases, Picture Frames, Wallets, Wrist Watch and Glasses **M**
Kavanagh Qc (T.V. Series, 1995-2001)

Actor John Thaw's director's chair and the personal effects belonging to his character, James Kavanagh, from the legal-drama TV series Kavanagh QC. The wooden director's chair includes a chair back with Thaw's name printed on it and a leather pouch hanging from one arm that contains a glass ashtray and old newspapers. The personal effects include two black leather cases; three black leather wallets; one Sekonda wristwatch; a gold-toned ring; one pair of reading glasses with a case (labelled "Kavanagh"); and a small wooden fold-out courtroom table. Also included are three picture frames, one of which features a photo of Kavanagh's son (labelled "Kav's House Son's Pic"); a travel alarm clock; a blue notepad featuring two pages of handwritten notes; and a green folder holding 12 copies of three printed sheets titled, "An outline of criminal process in England and Wales". The collection exhibits wear, including a hole in the felt table top, a broken stand on the largest picture frame, and scuffs to the leather briefcases. Dimensions (chair): 49 cm x 56 cm x 87.5 cm (19 1/4" x 22" x 34 1/2")

Estimate. £2,000 - 3,000



1102
Cleaner Costume **Ω**
Kin (2018)

A Cleaner costume from Jonathan and Josh Baker's sci-fi film Kin. A pair of masked individuals known as Cleaners, pursued Eli Solinski (Myles Tuit) throughout the film after he fired an otherworldly gun. This costume consists of a futuristic padded black fibreglass helmet affixed on the reverse with a battery-operated fan; a tan North Face balaclava riddled with production-made bullet holes; a bullet-riddled tan cotton zip-up jacket; a black cotton G-Star jacket with a metal-armoured chest plate; matching black trousers; a black leather belt affixed via metal poles with thigh armour labelled "Left" and "Right"; matching knee and shin armour; two matching leather left hand gloves; and a bullet-riddled grey and blue canvas backpack. The metal components exhibit scratching and stuffing is exposed in the bullet-riddled components. Contains electronics; see electronics notice in the Buyer's Guide.

Estimate. £2,500 - 3,500



1103
Stunt Kingsman Pistol **†Δ**
Kingsman: The Secret Service (2014)

A stunt Kingsman pistol from Matthew Vaughn's action film Kingsman: The Secret Service. The Kingsman agents' pistols were specifically designed for the production and were carried by multiple agents, including Galahad (Colin Firth), Galahad (Taron Egerton) and Lancelot (Jack Davenport). The pistol is made of foam rubber and hand-painted black, with the pistol featuring a brown, textured grip and a silver ejection port. It has some imperfections from the casting process. Dimensions: 19.5 cm x 3 cm x 12 cm (7 3/4" x 1 1/4" x 4 3/4") Restricted ownership; see replica firearm notice in the Buyer's Guide.

Estimate. £800 - 1,200

Propstore

**Sell Your
Movie Memorabilia**
Achieve world record prices for
entertainment memorabilia

Rogue One: A Star Wars Story (2016)

Light-up R2-M80/KR2-M80/R2-F1P

Remote Control Droid

sold for £125,000 (\$168,750)

incl. bp



Reach out for a free appraisal
and valuation with our specialists



Email: consign@propstore.com

Phone UK Office: +44 (0) 1494 766485

Phone US Office: +1 818 727 7829

Scan QR code to visit propstore.com/sell



1104
Tournament Herald's Trumpet with Banner Ω
A Knight's Tale (2001)

A tournament herald's trumpet with a banner from Brian Helgeland's historical comedy A Knight's Tale. Royal trumpeters announced the starts of the jousting tournaments William Thatcher (as played by Heath Ledger) competed in under false pretences. This lot consists of a long, mediaeval-style brass trumpet with a wide bell and two hooks from which hangs a red canvas banner with gold-colour fringes. The banner is embroidered with three blue and gold lion emblems representing the dominion of King Edward III. The instrument and banner both exhibit intentional distressing by production to appear antique with tarnishing and grime applied. Dimensions: 139 cm x 16.5 cm x 9 cm (54.75" x 6.5" x 3.5")

Estimate. £300 - 500

1105
Sarah's (Jennifer Connelly) Hoggle Statue \mathcal{M}
Labyrinth (1986)

Sarah's (Jennifer Connelly) Hoggle statue from Jim Henson's fantasy musical Labyrinth. Sarah's bedroom was filled with toys which foreshadowed the characters she later met on her adventures. She used a statue of the cantankerous dwarf Hoggle as a bookend. The statue is made of cast resin filled with plaster. It is hand-painted in shades of cream, brown and black, and features the inscription "Hoggle, Labyrinth, 1985" handwritten in black pen on the base. The item exhibits minor cracks and a nick to the left earlobe from production use and age. Dimensions: 8 cm x 8 cm x 16.5 cm (3 1/4" x 3 1/4" x 6 1/2")

Estimate. £3,000 - 5,000

1106
Slampot Goblin Test Head and Photographs Ω
Labyrinth (1986)

A Slampot Goblin test head and photographs from Jim Henson's fantasy adventure Labyrinth. Jareth (David Bowie) ruled over the Goblins who lived inside the Labyrinth, though the Slampot Goblin was ultimately unseen in the final cut. This cast resin miniature goblin head features a bird-shaped helmet with the metal-hinged visor, synthetic brow and nostril hair, and comes mounted to a wooden display labelled "Slampot" by production. Also included are three photographs: two of the head, hand-marked "Michael McCormick", and one of McCormick with puppets. The head exhibits scratching and paint scuffing from production, one photo exhibits staining. Dimensions (largest): 15.25 cm x 23 cm x 23 cm (6" x 9" x 9"); (smallest): 8.25 cm x 8.25 cm (3.25" x 3.25")

Estimate. £2,000 - 3,000



1107
Production-used Screenplay, Paperwork, Photographs, and Hand-Drawn Artwork Ω
Labyrinth (1986)

Production-used screenplay, paperwork, photographs, and hand-drawn artwork from Jim Henson's fantasy adventure Labyrinth. This lot consists of one 143-page third draft screenplay with a red cover and metal bindings; one small portfolio containing 14 loose photographs and 24 pages of additional photographs; a 58-page note and partial treatment packet; seven pages of pink revision script pages; a set of 31 small photographs and 98 instant-print photographs primarily of goblin armour; and two hand-drawn creature costume concepts. Some of the paper elements exhibit creasing or staining, and one of the photographs had a piece cut off by production. Dimensions (largest): 30.5 cm x 43.25 cm (12" x 17"); (smallest): 8.25 cm x 8.25 cm (3.25" x 3.25") Sold without copyright; see notice in Buyer's Guide.

Estimate. £1,500 - 2,500



1109
Martin Asbury Storyboards for the Goblin Attack \mathcal{M}
Labyrinth (1986)

A set of storyboards, hand-drawn by Martin Asbury, from the production of Jim Henson's fantasy film Labyrinth. The lot comprises three pages featuring 15 storyboards depicting the Goblin City battle sequence, when Jareth's (David Bowie) Golbin army attacked Sarah (Jennifer Connelly), Ludo, Sir Didymus and Ambrosius in an attempt to stop them from entering the castle. Rendered in pencil and ink, each drawing features a brief description, notes on camera angles and directional arrows. Tippex is applied to some illustrations. Dimensions (each sheet): 30 cm x 21 cm (11 3/4" x 8 1/4") Sold without copyright; see copyright notice in the Buyer's Guide.

Estimate. £1,000 - 1,500



1108
Martin Asbury Storyboards for Sarah Confronting Jareth on the Escher Staircase \mathcal{M}
Labyrinth (1986)

A collection of storyboards, hand-drawn by Martin Asbury, from the production of Jim Henson's fantasy film Labyrinth. The lot comprises seven pages featuring 33 storyboards depicting moments from the climatic Escher staircase sequence, when Sarah (Jennifer Connelly) confronted Jareth (David Bowie) and desperately searched for Toby (Toby Froud). Rendered in pencil and ink, each drawing features a brief description, notes on camera angles and directional arrows. Tippex is applied to some images on one page, and the storyboards exhibit marks and smudging. Dimensions (each sheet): 30 cm x 21 cm (11 3/4" x 8 1/4") Sold without copyright; see copyright notice in the Buyer's Guide.

Estimate. £1,000 - 1,500



1110
Martin Asbury Hand-drawn Post-production Storyboards for Book Project \mathcal{M}
Labyrinth (1986)

A set of storyboards hand-drawn by Martin Asbury for a making of book of Jim Henson's fantasy film Labyrinth. These storyboards were created during post-production at the request of Henson, as he planned to create a making-of book, which was never produced. Jareth's appearance was altered from the original storyboards to resemble David Bowie. The lot comprises 10 pages featuring 51 pencil-and-ink storyboards showing various moments, including the Ballroom sequence and the Escher staircase sequence. Each detailed drawing features a brief description and directional arrows. Tippex is applied to some images and there are signs of minor discolouration. Dimensions (each sheet): 30 cm x 21 cm (11 3/4" x 8 1/4") Sold without copyright; see copyright notice in the Buyer's Guide.

Estimate. £800 - 1,200



1111
Jim Henson Autographed One-Sheet M
Labyrinth (1986)

An autographed US one-sheet poster from the promotion of Jim Henson's fantasy film Labyrinth. The poster features artwork by Ted CoConis and shows a montage of all the characters, with Jareth (David Bowie) at the centre and Sarah (Jennifer Connelly) situated underneath in her elaborate ballroom gown. It is autographed and inscribed in blue marker by Jim Henson, with the inscription reading "John, thank you; Jim Henson" in the top left corner. The lot exhibits pinholes, creasing, and small tears near the lower right corner. Dimensions: 104 cm x 68.5 cm (41" x 27")

Estimate. £400 - 600



1113
Lamb Chop and Friends Puppets M
Shari Lewis

Three puppets used by the comedy ventriloquist and children's entertainer Shari Lewis. Lewis and her sock puppet companions were first introduced to television in March 1956 on the family show Captain Kangaroo, but in 1960 she received her own spot on NBC called The Shari Lewis Show. Throughout her career, Lewis was accompanied by a sweet and gentle puppet called Lamb Chop, along with various other characters, such as Charlie Horse, Hush Puppy and Wing Ding. This set includes Hush Puppy, an unknown brown dog, and the iconic Lamb Chop. Each is made from a sock, with button eyes, felt tongue and ears, and stuffed arms and legs. The puppets show light tears and loose stitching, but they remain in excellent condition. These particular puppets were previously gifted back to the family of the maker. Dimensions (each): 40 cm x 12 cm x 12 cm (15 3/4" x 4 3/4" x 4 3/4")

Estimate. £2,000 - 3,000



1112
Professor G.H. Dorr (Tom Hanks) String Bow and I.D.,
Garth Pancake's (J.K Simmons) Toolbelt Ω
Ladykillers, The (2004)

Professor G.H. Dorr's (Tom Hanks) bow and I.D. and Garth Pancake's (J.K. Simmons) toolbelt from the Coen Brothers' comedy remake The Ladykillers. Dorr masqueraded as a violinist and professor, and Garth wore a toolbelt. This lot consists of a wooden violin bow; a laminated ID; a filled toolbelt, two pairs of goggles, leather work gloves, and 11 extra foam tools. The lot exhibits ID peeling, production-added bow scratches, and toolbelt scratches, stains, and fading. Dimensions (largest): 73.75 cm x 4 cm x 1.5 cm (29" x 1.5" x 1"); (smallest): 30.5 cm x 30.5 cm x 30.5 cm (12" x 12" x 12")

Estimate. £600 - 800



1114
Martin Asbury Hand-drawn Pencil Storyboards for the
Final Sequence M
Lara Croft: Tomb Raider (2001)

A set of storyboards, hand-drawn by storyboard artist Martin Asbury, from the production of Simon West's action adventure Lara Croft: Tomb Raider. The lot comprises 37 pages depicting the final sequence in the orrery, where Croft (Angelina Jolie) faces off with the Illuminati. The majority of the pages each feature eight detailed drawings arranged in two columns of four, rendered in graphite pencil, blue colour pencil and ink. However, three sheets display 16 smaller storyboards. Each drawing has a hand-written scene description, and every column of four panels is numbered, from 1 to 82. Dimensions (each sheet): 30 cm x 21.5 cm (11 3/4" x 8 1/2") Sold without copyright; see copyright notice in the Buyer's Guide.

Estimate. £800 - 1,200



1115
Lara Croft's (Angelina Jolie) Stunt Underwater P11 Pistol Δ
Lara Croft Tomb Raider: The Cradle Of Life (2003)

Lara Croft's (Angelina Jolie) underwater P11 pistol from Jan de Bont's action-adventure sequel Lara Croft Tomb Raider: The Cradle of Life. Croft wielded her P11 during the film's opening sequence as she narrowly escaped Chen Lo's (Simon Yam) attack at the Luna Temple. The weapon is made of solid resin and features five separate barrels, safety switches, finger grip detailing, and a static trigger. The majority of the pistol is finished in black, with the barrels painted matt silver to resemble metal. Dimensions: 18.5 cm x 5.5 cm x 16.5 cm (7 1/4" x 2 1/4" x 6 1/2") Restricted ownership; see replica firearm notice in the Buyer's Guide.

Estimate. £2,000 - 3,000



1116
Torn Magical Movie Ticket M
Last Action Hero (1993)

A torn magical movie ticket from John McTiernan's action comedy Last Action Hero. Danny (Austin O'Brien) was given a curious golden ticket by the movie theatre attendant Nick (Robert Prosky); before Danny enters, Nick tears the ticket in half and sends him in. After some time, as Danny is enjoying the movie, the torn ticket begins to glow and suddenly a bundle of dynamite flies out of the screen - a sequence of events that leads him to be transported into the world of his action hero, Jack Slater (Arnold Schwarzenegger). The ticket is made from card with a metallic laminate on each side; it features black and red detailing including the seat, row number and floorplan of the theatre on the back. The ticket shows wear to the laminate and colour degradation. Dimensions: 7.5 cm x 7.5 cm (3" x 3")

Estimate. £2,000 - 3,000



1117
Benedict's (Charles Dance) Stunt Dan Wesson Revolver M
Last Action Hero (1993)

Benedict's (Charles Dance) stunt Dan Wesson revolver from John McTiernan's action comedy Last Action Hero. Benedict used his modified revolver throughout the film as he hunts down Danny (Austin O'Brien) and Jack Slater (Arnold Schwarzenegger). The weapon is made from black foam rubber and features a muzzle brake compensator on the end of the barrel and large, hand-hugging target grips. It is missing the adjustable target sight and shows exposed rough foam in places. Dimensions: 44.5 cm x 18 cm x 6 cm (17 1/2" x 7" x 2 1/4") Restricted ownership; see replica firearm notice in the Buyer's Guide.

Estimate. £1,000 - 1,500



1118
Nathan Algren's (Tom Cruise) Hero Cavalry Sword M
Last Samurai, The (2003)

Nathan Algren's (Tom Cruise) hero cavalry sword from Edward Zwick's historical war epic The Last Samurai. Algren uses his sabre in battle against the Samurai until his capture by Katsumoto (Ken Watanabe). The sword has a dulled steel blade with a slight curvature. Its handle is wrapped in black leather and gold-coloured wire, and includes a winding brass guard. The lot includes a steel scabbard, featuring two rings which allow the piece to attach to a belt. The metal has some tarnishing. Dimensions (in scabbard): 112 cm x 12 cm x 9 cm (44" x 4 3/4" x 3 1/2")

Estimate. £3,000 - 5,000



1119
General Hasegawa's (Togo Igawa) Tanto Sword and Sheath ΩΔ
Last Samurai, The (2003)

General Hasegawa's (Togo Igawa) tanto sword and sheath from Edward Zwick's historical drama The Last Samurai. The defeated Hasegawa used his tanto to commit seppuku with Lord Moritsugu Katsumoto (Ken Watanabe) acting as his kaishakunin. This lot consists of a urethane tanto with a blade painted silver-colour to resemble metal and a hilt painted black with gold-colour embellishments and sculpted to resemble cord wrapping, as well as a black plastic sheath with fabric cord looped through it. The blade exhibits some fracturing near the base. Dimensions (sheathed): 37 cm x 4 cm x 3.25 cm (14.5" x 1.5" x 1.25")

Estimate. £1,200 - 1,800



1120
Det. Robert Goren's (Vincent D'Onofrio), Det. Alex Eames' (Kathryn Erbe) and Michael Keppler's (Liev Schreiber) IDs †Δ
Law & Order: Criminal Intent (T.V. Series, 2001-2011) & CSI: Crime Scene Investigation (T.V. Series, 2000-2015)

Det. Robert Goren's (Vincent D'Onofrio) and Det. Alex Eames' (Kathryn Erbe) IDs from Law & Order: Criminal Intent, and Michael Keppler's (Liev Schreiber) ID from CSI: Crime Scene Investigation. Detectives Goren and Eames wore their IDs during scenes in which the squad are in the department offices. Made from credit card-sized pieces of laminated card, the IDs feature headshots of D'Onofrio and Erbe, as well as character information. Michael Keppler wore his ID during his four-episode arc in Season 7. Made of thin plastic and bearing the Las Vegas Police logo, the white ID card features a photograph of Keppler with his information and job title. The IDs have some minor creasing to the plastic. Dimensions (largest): 11 cm x 6.5 cm (4 1/4" x 2 1/2")

Estimate. £600 - 800



1121
French Connection UK-branded Drug Cartons M
Layer Cake (2004)

A set of six French Connection UK-branded cartons from Matthew Vaughn's crime thriller Layer Cake. French Connection UK products featured in the film's opening montage, during which the unnamed protagonist (Daniel Craig) theorised that illegal drugs will eventually be made legal, his point illustrated by a series of imaginary shop shelves selling French Connection UK-branded drugs. The front of each paperboard carton features the FCUK logo and the name of the narcotic product contained within: ecstasy, LSD, cocaine, heroin, crack and speed, respectively. Three of the six cartons also include slogans at the front. The rear of the cartons incorporate the FCUK logo and a barcode. While most established brands might have been reluctant to engage in such a risky piece of marketing, the executive producer of the film was Stephen Marks, who was also the founder, chairman and CEO of French Connection Group PLC. Dimensions (largest): 14.5 cm x 8 cm x 8 cm (5 3/4" x 3 1/4" x 3")

Estimate. £1,000 - 1,500



1123
Zorro (Antonio Banderas) and Elena's (Catherine Zeta-Jones) Wedding Band, Divorce Filing, and Ring Pillow Ω
Legend Of Zorro, The (2005)

Zorro (Antonio Banderas) and Elena's (Catherine Zeta-Jones) wedding band, divorce filing, and ring pillow from Martin Campbell's swashbuckling sequel The Legend of Zorro. Armand (Rufus Sewell) forced Elena to serve her husband Zorro with divorce papers. This lot consists of an engraved silver-colour metallic ring; a document with cursive text printed in red and black ink titled "Issuance of Proceedings for Divorce," dated "June 23, 1849," and aged by production; and a cotton-filled white velvet pillow with brown tassels and embroidered flowers. Dimensions (largest): 30.5 cm x 23 cm (12" x 9"); (smallest): 2.5 cm x 2.5 cm x 2.5 cm (1" x 1" x 1")

Estimate. £800 - 1,200



1122
Zorro (Antonio Banderas) and Count Armand's (Rufus Sewell) Stunt Swords Ω
Legend Of Zorro, The (2005)

Zorro (Antonio Banderas) and Count Armand's (Rufus Sewell) stunt swords from Martin Campbell's swashbuckling sequel The Legend of Zorro. Zorro and Armand duelled atop a train filled with nitroglycerin. This lot consists of two urethane stunt sabres. One features a cupped and grated hilt, a black handle textured with studs painted silver-colour, and a round silver-colour pommel. The other features a grip painted bronze and engraved with a smiling face and fleur-de-lis. The latter blade exhibits bending from production use with knicks visible on both. Dimensions (each): 98 cm x 18 cm x 6.5 cm (38.5" x 7" x 2.5")

Estimate. £1,500 - 2,500



1124
Knights of Aragon Crate with Nitroglycerin Vials Ω
Legend Of Zorro, The (2005)

A Knights of Aragon crate with nitroglycerin vials from Martin Campbell's swashbuckling sequel The Legend of Zorro. The Knights of Aragon, the secret society controlling world affairs, placed crates filled with nitroglycerin on the Governor of California's (Pedro Armendariz) train. This lot consists of a wooden crate stamped "Orbis Unum," or "One World," on top, an additional crate lid damaged by production to appear exploded, and 18 cork-stoppered glass vials containing clear liquid in a production baggie labelled "hero bottle." The bottles exhibit sticky seepage, and the liquid is not safe for consumption. Dimensions: 63.5 cm x 40.75 cm x 38.25 cm (25" x 16" x 15")

Estimate. £600 - 800



1125
Harrigan's (Michael Emerson) Ring and Felipe's (Julio Oscar Merchoso) Bullet-shot Crucifix Ω
Legend Of Zorro, The (2005)

Harrigan's (Michael Emerson) ring and Felipe's (Julio Oscar Merchoso) bullet-shot crucifix from Martin Campbell's swashbuckling sequel *The Legend of Zorro*. Harrigan pricked Zorro (Antonio Banderas) with a needle concealed in his ring, and Father Felipe's crucifix saved him from being shot by McGivens (Nick Chinlund). This lot consists of a metal ring and a metal crucifix with floral engravings and a chain necklace embedded with a round bullet. Both exhibit tarnishing from age and production use. Dimensions (ring): 4 cm x 4 cm x 4 cm (1.5" x 1.5" x 1.5"); (crucifix): 10.25 cm x 7.75 cm x 1.5 cm (4" x 3" x 0.5")

Estimate. £600 - 800



1126
Elena's (Catherine Zeta-Jones) Pipe Ω
Legend Of Zorro, The (2005)

Elena's (Catherine Zeta-Jones) pipe from Martin Campbell's swashbuckling sequel *The Legend of Zorro*. Elena smoked a pipe in front of Count Armand (Rufus Sewell), saying she "stepped out for a puff," to cover up that she was actually on the balcony talking to Zorro (Antonio Banderas). This resin pipe features a translucent brown stem and a white bowl decoratively sculpted to resemble a rose. Dimensions: 19.25 cm x 5.25 cm x 5.25 cm (7.5" x 2" x 2")

Estimate. £600 - 800



1127
Turpentine Jug Ω
The Lighthouse (2019)

A turpentine jug from Robert Eggers' psychological drama *The Lighthouse*. Desperate for entertainment, Thomas Howard (Robert Pattinson) made a noxious turpentine concoction for fellow lighthouse keeper Thomas Wake (Willem Dafoe), who declared the drink "Monkey pump!" This tin jug originated with a crew member. It features a brown wooden handle, a soldered spout, and a "Pure Gum Spirits Turpentine - 1 gal." label applied to the front. The interior was varnished by production to make it safe for drinking, and the exterior exhibits ornate distressing to appear aged, stained, and rusted by brine. Dimensions: 20.5 cm x 20.5 cm x 23 cm (8" x 8" x 9")

Estimate. £1,000 - 1,500

1128
Satan's (Harvey Keitel) Sceptre Ω
Little Nicky (2000)

Satan's sceptre from Steven Brill's comedy *Little Nicky*. Adrian (Rhys Ifans) held the sceptre after seizing the throne of Hell from his weakened father, Satan (Harvey Keitel). This brown-painted fibreglass sceptre resembles a carved branch with a tapered ribbed stem and three smaller arms forking out at the top. It features metal plating around the base of each branch and plastic crystals protruding from the flat top of the main stem. There is a split in the metal plating. Dimensions: 86 cm x 39 cm x 33 cm (34" x 15 1/2" x 13")

Estimate. £1,000 - 1,500



1129
Rubber Demon Darts, Crew Gifts and Hockey Pucks Ω
Little Nicky (2000)

A set of crew gifts and hockey pucks from the production of Steven Brill's comedy *Little Nicky*. The lot comprises two official NHL Stanley Cup hockey pucks, a metal hand warmer engraved with "Little Nicky", and a metal "Concord" hip flask engraved with "Eugene Little Nicky 3-2-00". The hand warmer comes in a red cotton pouch, along with an instruction card. These are boxed in the hand warmer's original packaging, which has been wrapped in Christmas paper. The metal hip flask comes in its branded box. There is some disintegration of the stickers on the hockey pucks. Dimensions (hip flask): 16.5 cm x 8 cm x 2cm (6 1/2" x 3 1/4" x 3/4")

Estimate. £400 - 600





1130
Three "Jamboree" Scripts Ω
Lord Of The Rings Trilogy, The
(2001 - 2003)

Three "Jamboree" scripts from the production of Peter Jackson's fantasy epic trilogy The Lord of the Rings trilogy. This lot comprises a red canvas-bound script for each film in the trilogy and a set of promotional ephemera. The script for The Fellowship of the Ring consists of 214 pages printed on multicoloured paper, six of which detail the scene master list and feature sticky notes. The scripts for The Two Towers and The Return of the King contain 166 pages and 165 pages, respectively, and both are printed on multicoloured paper. Each script includes a false title page featuring the production's code name "Jamboree", and a "Carla #1" watermark is printed on the subsequent pages. The promotional ephemera includes an invitation to the world premiere of The Fellowship of the Ring and an after-party pass. These come in an envelope addressed to the executive in charge of production Carla Fry. Also included is a small leather-bound booklet containing the film's synopsis and stills of the principal actors in character. Dimensions (one script): 31 cm x 23.5 cm x 3 cm (12 1/2" x 9 1/2" x 1 1/2")

Estimate. £2,000 - 3,000



1132
Hand-drawn Mumakil Design and
Set Design Copies \mathcal{M}
Lord Of The Rings Trilogy, The
(2001 - 2003)

A hand-drawn mumakil design and set design copies from the production of Peter Jackson's The Lord of the Rings trilogy. This lot includes a pencil drawing of a mumakil, the elephant-like beast ridden by the Haradrim, drawn onto thick tracing paper. It includes technical and scale information. The set designs relate to miniatures built at Dry Creek Quarry near Wellington, New Zealand, which was the site of The Hornburg in The Two Towers and Minas Tirith in The Return of the King. The set designs feature highlighting and some handwritten annotations. The pages have minor staining, tears to the edges and have been rolled for storage. Dimensions (mumakil design): 59 cm x 83.5 cm (23 1/4" x 32 3/4") Sold without copyright; see copyright notice in the Buyer's Guide.

Estimate. £500 - 700



1131
Prosthetic Hobbit Feet \mathcal{M}
Lord Of The Rings Trilogy, The
(2001 - 2003)

A pair of Hobbit feet from Peter Jackson's epic fantasy trilogy The Lord of the Rings. Because of their leathery tough soles and thick warm hair, Hobbits walked barefoot throughout the trilogy. This pair of foam-latex prosthetic Hobbit feet were made by the Weta Workshop make-up and prosthetics department. They were cast from individual moulds of the performer's feet, which were then enlarged and hand-painted in peachy skin tones, with a layer of real dark brown hair applied to the top of the foot. Hobbit feet like these were never typically reused, as they were glued to the actor's feet for filming, making it difficult to keep the prosthetics intact during the removal process. The lot exhibits wear from production use, including staining and peeling on the soles, and there is a small split at the ankle of the right foot. Dimensions (each): 24 cm x 12 cm x 10 cm (9.5" x 4 3/4" x 4")

Estimate. £1,500 - 2,500

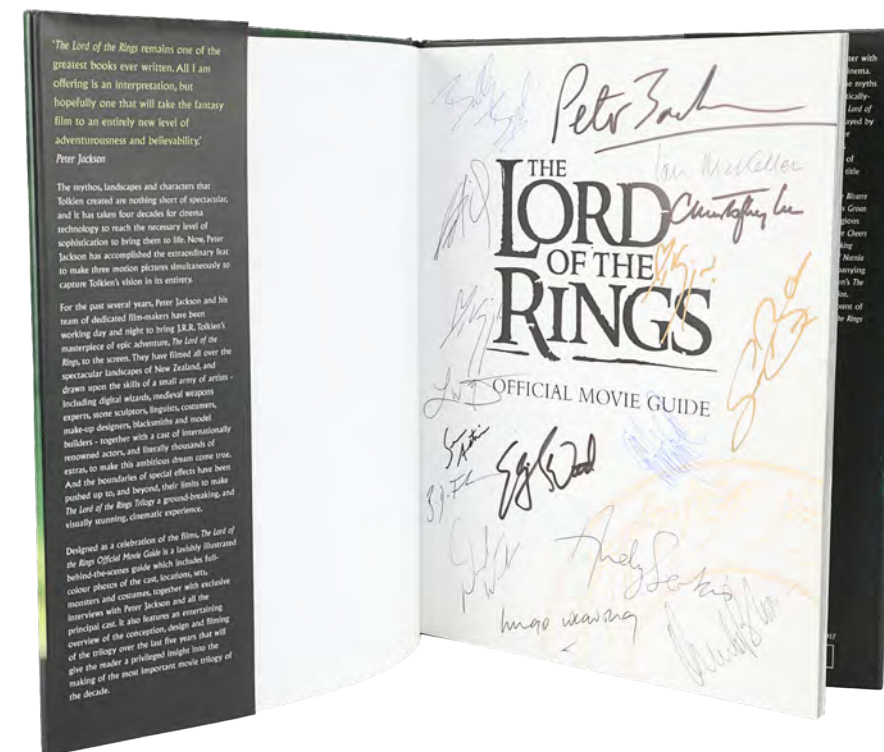

1133
Peter Jackson and Main Cast
Autographed Movie Guide Book \mathcal{M}
Lord Of The Rings: The Fellowship
Of The Ring, The (2001)

A movie guide book autographed by the main cast of Peter Jackson's fantasy epic The Lord of the Rings: The Fellowship of the Ring. The title page of the Official Movie Guide by Brian Sibley has been autographed by 16 cast and crew, including Elijah Wood (Frodo Baggins), Viggo Mortensen twice (Aragorn), Ian McKellen (Gandalf) and director Jackson. Dimensions: 29 cm x 23 cm x 1.5 cm (11 1/2" x 9" x 1/2")

Estimate. £3,000 - 5,000



1134
Gandalf's (Ian McKellen) Party Firework 
Lord Of The Rings: The Fellowship Of The Ring, The (2001)

Gandalf's (Ian McKellen) party firework from Peter Jackson's adaptation of J.R.R. Tolkien's epic fantasy novel The Lord of the Rings: The Fellowship of the Rings. Gandalf brought fireworks to Bilbo's (Ian Holm) 111th birthday to aid in the festivities. This style of firework resembles a large magical mushroom and this style can be seen under Gandalf's arm and in his cart before it's raided by Pippin (Billy Boyd) and Merry (Dominic Monaghan). The firework is made from paper mache painted blue with a red cap and it is attached to a hand-carved wooden rod by two pieces of rope. The item comes with a letter of authenticity from production company New Line Cinema. Dimensions: 44 cm x 15 cm x 15 cm (17" x 6" x 6")

Estimate. £3,000 - 5,000



1135
Dharma Initiative Beer Can 
Lost (T.V. Series, 2004 - 2010)

A Dharma Initiative beer can from sci-fi mystery series Lost. Workers of the Dharma Initiative ate and drank only products made by Dharma. The unsealed, empty can features the same plain white design as the other Dharma products with the geometric black Dharma label. The can reads "Dharma Initiative Beer" and features a barcode and Surgeon General's warning on the side. The can has some minor staining and dents. Dimensions: 6.5 cm x 6.5 cm x 12.5 cm (2 1/2" x 2 1/2" x 5")

Estimate. £600 - 800



1136
Penny Robinson's (Mina Sundwall) Spacesuit Components, Stunt Backpack, Journal, and Pencils 
Lost In Space (T.V. Series, 2018 - 2022)

Penny Robinson's (Mina Sundwall) spacesuit components, stunt backpack, journal, and pencils from Legendary Television's sci-fi series Lost in Space. In Season 1, Penny wore her spacesuit when she escaped the Resolute. In the Season 2 episode "Shipwrecked," Will (Maxwell Jenkins) gave the Robinsons copies of Penny's space travel journal as Christmas gifts. This lot consists of a navy blue lycra and nylon blend jacket marked "Penny 2 Hero Season 3"; matching trousers; a grey plastic wrist communicator; a hand-painted grey and orange foam backpack labelled "Robinson"; a paper journal labelled "Lost in Space by Penny Robinson"; and two green graphite PEFC pencils. They exhibit scratching and paint flaking from production use.

Estimate. £1,500 - 2,500



1138
Maureen Robinson's (Molly Parker) Spacesuit Components and Wrist Communicator 
Lost In Space (T.V. Series, 2018 - 2022)

Maureen Robinson's (Molly Parker) spacesuit components and wrist communicator from Legendary Television's sci-fi series Lost in Space. Maureen wore her spacesuit throughout the series, including when she escaped the Resolute with her family in Season 1 and when she got caught in an oceanic trench in Season 2. This costume consists of one navy blue rubberized, printed lycra blend jacket with nylon leather components, metal cinching buckles, orange accents, and "Maureen Stunt" and "Maureen Spacesuit S1" marked on the interior; matching trousers marked "2 Maureen" and "Prisha Dhar"; and a static grey plastic wrist communicator with elastic straps. This costume exhibits some stains and the communicator exhibits scratching from production use.

Estimate. £1,000 - 1,500



1137
Dr. Smith's Stunt Spacesuit Components with Wrist Communicator 
Lost In Space (T.V. Series, 2018 - 2022)

Dr. Smith's stunt spacesuit components with a wrist communicator from Legendary Television's sci-fi series Lost in Space. In the Season 1 episode "Diamonds in the Sky," Dr. Smith (Parker Posey) wore her spacesuit when she survived the Jupiter 18 crash landing. This costume consists of one navy blue rubberized, printed lycra blend jacket with nylon and leather components, orange accents, an FBF tag labelled "Parker Posey Dr. Smith 'Lost in Space,'" and "Smith Stunt" marked on the interior; matching trousers marked "Smith S1"; and a static grey plastic wrist communicator with hook-and-loop fasteners and an elastic strap. They exhibit scratches and discoloration on the trousers and knee guards from production.

Estimate. £800 - 1,200



1139
Will Robinson's (Maxwell Jenkins) Cold Weather Jacket with Mission 24 Patch and Camcorder 
Lost In Space (T.V. Series, 2018 - 2022)

Will Robinson's (Maxwell Jenkins) cold weather jacket with a Mission 24 patch and a camcorder from Legendary Television's sci-fi series Lost in Space. In the Season 1 episode "Impact," Will wore his jacket when he explored the icy planet his family crashed on, and later recorded his interactions with the Alien Robot. This lot consists of a futuristic grey leather and nylon jacket with a Mission 24 patch embroidered on the left arm, orange trim, synthetic fur detailing, and mesh pockets, as well as a nonfunctional black metal and plastic RICOH camcorder. This lot exhibits some scratches and loose threads from production. Contains electronics; see electronics notice in the Buyer's Guide.

Estimate. £1,200 - 1,800



1140
Maureen Robinson's (Molly Parker) Cold Weather Jacket with Mission 24 Patch Ω
Lost In Space (T.V. Series, 2018 - 2022)

Maureen Robinson's (Molly Parker) cold weather jacket with a Mission 24 patch from Legendary Television's sci-fi series Lost in Space. In the Season 1 episode "Impact," Maureen wore her jacket over her spacesuit to keep warm while nursing a leg injury earned during her escape from the Resolute. This jacket is made primarily of brown leather and nylon with a Mission 24 patch embroidered on the left arm, orange trim, synthetic fur detailing on the back, and mesh pockets on the chest. The interior is hand-marked "2 Maureen." This jacket exhibits white stains on the front from synthetic ice created by production.

Estimate. £500 - 700



1141
Set of Three Judy Robinson (Taylor Russell) Jackets Ω
Lost In Space (T.V. Series, 2018 - 2022)

Three Judy Robinson (Taylor Russell) jackets from Legendary Television's sci-fi series Lost in Space. Judy wore various jackets throughout the series, including while on Jupiter 2 and on other planets. This lot consists of three leather zip-up jackets: one beige, one black, and one grey corded trim on brown insets. Each features mesh and nylon detailing, and the beige jacket, which is hand-labelled "#5 Judy," features an attached strap around the waist. The set exhibits minor cracking to the leather and some discolouration from production.

Estimate. £500 - 700



1142
John (Toby Stephens) and Maureen Robinson's (Molly Parker) Leather Jackets Ω
Lost In Space (T.V. Series, 2018 - 2022)

John (Toby Stephens) and Maureen Robinson's (Molly Parker) leather jackets from Legendary Television's sci-fi series Lost in Space. The Robinsons wore their respective leather jackets throughout the series. This lot consists of two leather zip-up jackets, one chestnut brown with navy blue insets labelled "John" and "John's Brown Leather Jacket," as well as one tan with a barcoded tag labelled "Maureen" on the sleeve and "Maureen" hand-marked on the interior. Both exhibit cracking and mild discolouration to the leather from production wear.

Estimate. £500 - 700



1143
Will Robinson's (Maxwell Jenkins) Breakaway Toy Robot Ω
Lost In Space (T.V. Series, 2018 - 2022)

Will Robinson's (Maxwell Jenkins) breakaway toy robot from Legendary Television's sci-fi series Lost in Space. In the Season 1 episode "Pressurized," Will destroyed a toy robot his sister Penny (Mina Sundwall) made him to cope with the loss of the Alien Robot. This plastic toy robot was constructed from various "scavenged" white and grey plastic pieces and custom-made by production to be broken. It features long black hands and a black head with a clear plastic dome over the face to mimic the Alien Robot's signature dome helmet. The plastic exhibits some smudging and microfractures from use. Dimensions: 35.75 cm x 15.25 cm x 7.75 cm (14" x 6" x 3")

Estimate. £500 - 700



1144
Guru Pitka's (Mike Myers) Self-help Books and Chicken-attack Sleeve Ω
Love Guru, The (2008)

Guru Pitka's (Mike Myers) self-help books and a chicken-attack sleeve from Marco Schnabel's comedy The Love Guru. Pitka held up his books at various points throughout the film and was attacked by a rooster while trying to deliver a letter to Prudence Roanoke (Meagan Good). The five hardback books feature different titles and differently coloured dust jackets, each one wrapped around a copy of Charles Foster's Stardust and Shadows: Canadians in Early Hollywood. The chicken-attack sleeve has been intentionally distressed with tears and stage blood. Dimensions (each book): 23.5 cm x 16 cm x 3 cm (9 1/4" x 6 1/4" x 1 1/4")

Estimate. £800 - 1,200



1145
Justin Timberlake Autographed Hockey Stick and Elephant Flower Garland Ω
Love Guru, The (2008)

An ice hockey stick autographed by Justin Timberlake and a garland of flowers from Marco Schnabel's romantic comedy The Love Guru. Jacques "Le Coq" Grandé (Timberlake) used an ice hockey stick while keeping goal for the Los Angeles Kings. Lucy the elephant wore flowers as she was led into the ice hockey arena by Jane Bullard (Jessica Alba). Made of wood and painted in black and white, the blade of the ice hockey stick is wrapped in tape upon which Timberlake has written "Eugene: Props!!! Always my favourite department..." followed by his autograph. Eugene McCarthy was a property master on the film. The garland features 33 pink polyester chrysanthemums attached to the webbing of an aeroplane seatbelt. The shaft of the ice hockey stick is broken and the upper half is not included with this lot. Dimensions: (ice hockey stick) 94 cm x 23 cm x 2.5 cm (37" x 9" x 1")

Estimate. £600 - 800



1146
Mazikeen's (Lesley-Ann Brandt) Stunt Karambit Ω
Lucifer (T.V. Series, 2016 - 2022)

Mazikeen's (Lesley-Ann Brandt) stunt karambit from the crime drama series Lucifer. Mazikeen used her karambit in hand-to-hand combat when fighting against Lucifer Morningstar's (Tom Ellis) enemies throughout the series. This sickle-shaped cast resin weapon features aommel ring and a feather-like etching on the flat sides, along with engraved symbols. The blunt concave edge features bamboo-like notching and the convex edge is double-bevelled to appear sharp. Finished with silver-coloured paint, the karambit exhibits some scratching and visible paint lines on the handle from production use. Dimensions: 18.5 cm x 4 cm x 0.75 cm (7.25" x 1.5" x 0.25")

Estimate. £400 - 600



1147
 Macbeth's (Michael Fassbender) Stunt Swords †Δ
Macbeth (2015)

Macbeth's (Michael Fassbender) stunt swords from Justin Kurzel's adaptation of Shakespeare's tragedy Macbeth. Macbeth used his pair of swords - a traditional longsword and a short sword - during the opening battle, and in his final duel with Macduff (Sean Harris). Both swords are made of hard rubber with metal armatures. The blades are finished in metallic paint to replicate the appearance of blackened, worked steel, and the grips are bound in faux leather. Well-used in the film's battle sequences, there is some minor rubber delamination on the short sword blade, and some paint is coming away. Dimensions (longsword): 98 cm x 22.5 cm x 4 cm (38 1/2" x 8 3/4" x 1 1/2"); (short sword) 71 cm x 10 cm x 3 cm (28" x 4" x 1 1/4")

Estimate. £800 - 1,200

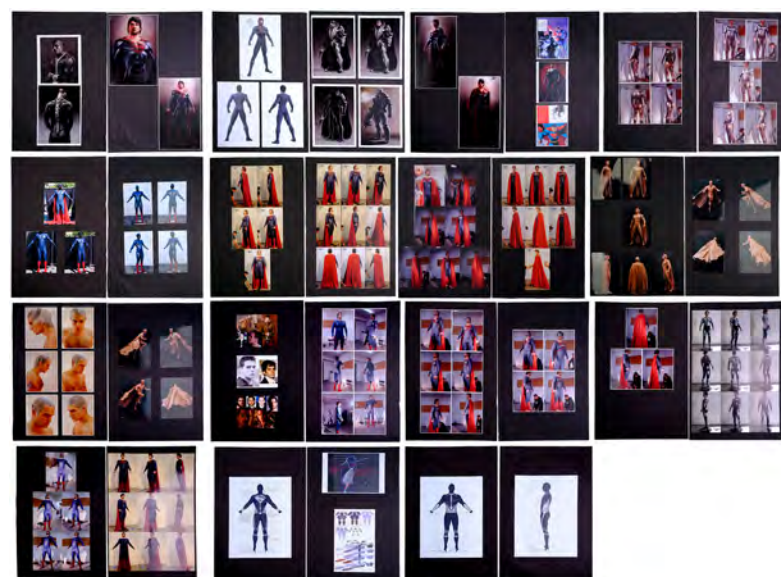

1148
 30 Pages of Printed Superman (Henry Cavill) Suit
 Concept Designs and Photos Ω
Man Of Steel (2013)

30 pages of printed Superman (Henry Cavill) suit concept designs and photos from Zack Snyder's superhero film Man of Steel. Jor-El (Russell Crowe) presented his son Kal-El with what would become his signature Kryptonian suit. This lot consists of 30 black construction paper pages featuring printed costume concept design, printed inspiration images from comics, maquette photographs, hair and makeup photographs of Cavill, and test photographs of suits on mannequins and Cavill. These designs were created and printed by specialty costuming firm Frontline Design during pre-production and feature their watermark. Some prints additionally feature notations, dates, and attributions to artists such as costume illustrator Warren Manser. They exhibit minor creasing and edge wear. Dimensions (each): 63.5 cm x 94 cm (25" x 37")

Estimate. £2,000 - 3,000

1149
 Fan-operated Marilyn Monroe
 Subway Grate Display with Replica
 White Dress M
Marilyn Monroe

A fan-operated Marilyn Monroe subway grate display with a replica white dress. In Billy Wilder's romantic comedy The Seven Year Itch, Monroe wore a white dress as she stood above a windy subway grate. This item pays homage to one of the most iconic moments in movie history. The display features a full-size fibreglass mannequin posed just as Monroe appeared in the scene. It includes a synthetic blonde wig, synthetic eyelashes, resin teeth, and hand-painted blue eyeshadow and red lipstick. The mannequin is dressed in a replica white halterneck dress and white leather strap heels. Areas at the top of the dress have been lightly glued to the mannequin to keep it in place. The mannequin stands upon a large working plug-in fan (UK 240V) set inside a metal grill, so the subway-grate scene can come to life. Accompanying the lot is a white leather clutch bag, which has been filled to retain its shape. The display exhibits rusting to the metal base, and stains and discoloration on the white dress from handling and age. Dimensions: 53 cm x 55 cm x 185 cm (21" x 21 3/4" x 73") Contains electronics; see electronics notice in the Buyer's Guide. Special shipping required; see special shipping notice in the Buyer's Guide.

Estimate. £1,000 - 1,500



1150
 Martian Blaster M
Mars Attacks! (1996)

A Martian blaster from Tim Burton's sci-fi comedy Mars Attacks! Martians used their blasters to vaporise the US Congress and attack Washington D.C., as well as several other cities, in their plan to terrorise Earth. The otherworldly blaster is made of dense rubber painted in bright red and green, with black and silver-coloured detailing. There are signs of paint chipping, and cracking is visible on the barrel from handling. The lot should be handled with care and is accompanied by a Warner Bros. certificate of authenticity. Dimensions: 38.5 cm x 6 cm x 17 cm (15 1/4" x 2 1/4" x 6 3/4")

Estimate. £3,000 - 5,000

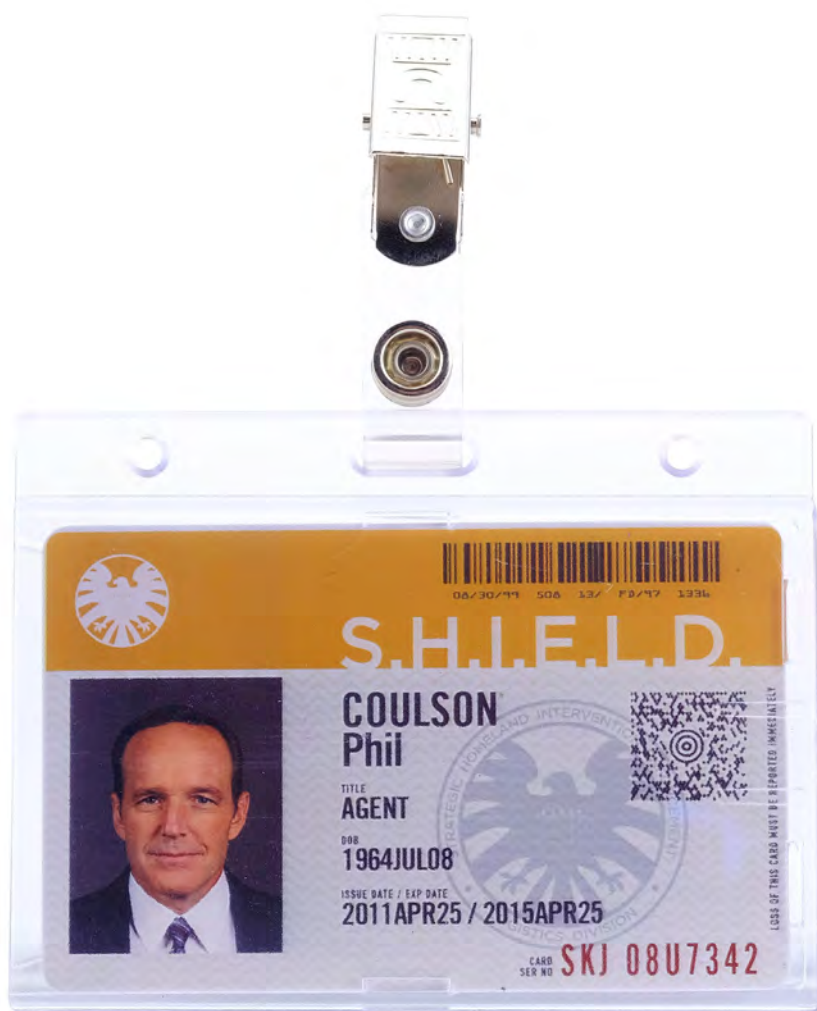

1151
 Agent Phil Coulson's (Clark Gregg)
 S.H.I.E.L.D. ID 
Marvel's Agents Of S.H.I.E.L.D. (T.V. Series, 2013 - 2020)

Agent Phil Coulson's (Clark Gregg) S.H.I.E.L.D. ID from Marvel's Agents of S.H.I.E.L.D. Coulson wore his personalised ID throughout the series, including in the pilot episode. This double-sided plastic ID card features the S.H.I.E.L.D. logo and name in white lettering over a mustard yellow background with Coulson's photo, birthdate "1964JUL08," issue date "2011APR25," expiration date "2015APR25," and serial number "SKJ08U7342" printed below. The card is encased in plastic with a metal clip and exhibits slight purpling from production use and exposure. Dimensions: 10.25 cm x 9.5 cm (4" x 3.75")

Estimate. £2,500 - 3,500



1152
 Trinity's (Carrie Anne Moss) SFX
 Rooftop Knife 
Matrix, The (1999)

Trinity's (Carrie Anne Moss) SFX rooftop knife from the Wachowskis' sci-fi action thriller The Matrix. Trinity took a knife from a SWAT operative during the rooftop showdown and used it while rescuing Morpheus. This SpecPlus Marine sp1-95 combat knife features a steel blade with a serrated edge and a black plastic handle with a spherical compass built into its end. The knife is modified to include a metal rod with a painted blue stripe extending from the grip guard, which was used to help with the effects of Trinity's death-defying knife skills. This piece exhibits a blunted tip, scuffs and rusting from production use and age. Dimensions: 31.5 cm x 12 cm x 3.5 cm (12 1/2" x 4 3/4" x 1 1/2")

Estimate. £3,000 - 5,000



1153
 Capt. B.J. Hunnicutt's (Mike Farrell) Bathrobe with
 Photo 
M*A*S*H (T.V. Series, 1972 - 83)

Captain B.J. Hunnicutt's (Mike Farrell) bathrobe with a photo from the legendary television series MASH. Hunnicutt wore his robe during martini time from season three onward. This costume consists of a yukata-inspired cotton bathrobe. It features a print of traditional Japanese art depicting dragons, tigers, waves, and Mount Fuji in neutral earth tones. The bathrobe features pockets and a black collar with white Japanese characters. The black-and-white photograph is 25 cm x 20 cm and features Hunnicutt wearing his robe, Hawkeye Pierce (Alan Alda), Father John Mulcahy (William Christopher), and Major Charles Emerson Winchester III (David Ogden Stiers). This lot exhibits some tearing along the seams and mild ripping in the fabric.

Estimate. £1,500 - 2,500



1154
 Neo's VFX Burly Brawl Fight Coat 
Matrix Reloaded, The (2003)

Neo's VFX Burly Brawl fight coat from the Wachowskis' sci-fi sequel The Matrix Reloaded. This version of the coat was worn by martial arts stunt coordinator Chad Stahelski - also Keanu Reeves' stunt double - during the fight sequence known as the "Burly Brawl". The coat was split into two halves so it could be worn with a special twisting belt harness, to create the effect of Neo twisting in the air. Visual effects were then applied during post-production to hide the belt and combine both halves of the costume. The cropped black textured woollen coat features a mandarin-style collar and covered buttons running down the front. Several white-coloured VFX tracking markers are sewn around the jacket's lower half, and several strips of black elastic hang from the hem. A label on the inside of the coat reads "Chad - Superfight, Twist Belt Fit". Some of the tracking markers are missing from the jacket.

Estimate. £3,000 - 5,000



1155
The Twins' (Adrian and Neil Rayment) Stunt Machine Gun M
Matrix Reloaded, The (2003)

A Twins (Adrian and Neil Rayment) stunt machine gun from The Wachowskis' action sci-fi sequel The Matrix Reloaded. During the highway car chase, one of the Twins fired his Heckler & Koch machine gun at Morpheus (Laurence Fishburne) and Trinity's (Carrie-Anne Moss) car. Dimensions: 69 cm x 6.5 cm x 37 cm (27 1/4" x 2 1/2" x 14 1/2") Restricted ownership; see replica firearm notice in the Buyer's Guide.

Estimate. £1,500 - 2,500



1156
John McVicar's (Roger Daltrey) Prisoner Identification Board †
McVicar (1980)

John McVicar's (Roger Daltrey) prisoner identification board from Tom Clegg's crime drama McVicar. A wall-mounted slatted identification board appeared adjacent to McVicar's prison cell door in the opening scenes of the film. The board is made of wood and bears a stamped logo denoting "Her Majesty's Prison" in black ink. It has a drilled hole at the top for ease of hanging. The individual cards are made of paperboard and McVicar's details are handwritten on each card with a black marker pen. Dimensions: 29 cm x 15 cm x 1.5 cm (11 1/4" x 6" x 1/2")

Estimate. £800 - 1,200

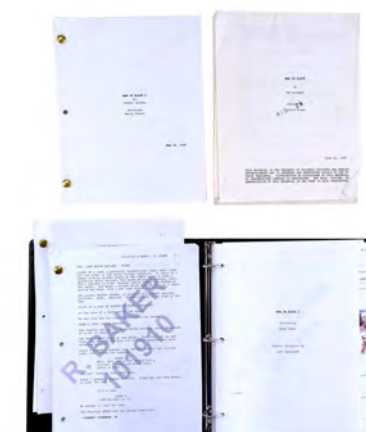

1159
Collection of Men In Black Scripts and Paperwork Ω
Men In Black (1997) / Men In Black II (2001) / Men In Black 3 (2012)

A collection of scripts and paperwork from Barry Sonnenfeld's Men in Black films. This set consists of one 1995 script draft for the 1997 film written by Ed Solomon and revised by David Koepp; two drafts of the sequel written in 2001 by Robert Gordon and revised by Barry Fanaro; one script for Men in Black 3 dated October 19, 2010, and character breakdowns for "HQ 1969 Immigration" and "Cosmic Bowl" scenes in Men in Black 3. The scripts exhibit corner creasing and the binder exhibits wear to its plastic exterior. Dimensions: (each) 21.75 cm x 28 cm x 2.75 cm (8.5" x 11" x 1")

Estimate. £800 - 1,200



1160
Pair of Agency Blasters Ω
Men In Black II (2002)

A pair of agency blasters from Barry Sonnenfeld's sci-fi comedy-action sequel Men in Black II. Agents K (as played by Tommy Lee Jones) and J (as played by Will Smith) stopped by K's old apartment, which was now inhabited by another family, to access his hidden armoury full of advanced weaponry from the agency. These two blasters are constructed primarily of resin with a silver-colour finish, scopes, vented grips, and greebles including small knob-like details. The paint exhibits chipping and one of the scopes has broken off. Dimensions (each): 30.5 cm x 20.5 cm x 7.75 cm (12" x 8" x 3")

Estimate. £1,000 - 1,500



1157
Medusa Plaque Ω
Medusa Touch, The (1978)

A plaque depicting Medusa from Jack Gold's supernatural horror The Medusa Touch. A plaque hung above a mantelpiece in the living room of John Morlar's (Richard Burton) flat and juxtaposed the opening credits. Detective Inspector Brunel (Lino Ventura) and Sgt. Duff (Michael Byrne) discussed the mythology and unsightliness of Medusa while viewing the plaque. This one differs slightly from the version on screen. It has a hexagonal wooden Whistler-style frame and red velvet matting. A circular ceramic centre depicts the severed head of Medusa against a green background. At the rear of the plaque is a metal wire fastened against two metal D-rings. One of the snakes is slightly chipped but the plaque is otherwise in good condition. Dimensions: 75 cm x 75 cm x 4 cm (29 1/2" x 29 1/2" x 1 1/2")

Estimate. £800 - 1,200



1158
Agents Kay (Tommy Lee Jones) and Jay's (Will Smith) FBI IDs Ω
Men In Black (1997)

Agents Kay (Tommy Lee Jones) and Jay's (Will Smith) FBI IDs from Barry Sonnenfeld's sci-fi comedy Men in Black. The Men in Black flashed FBI IDs when they questioned Beatrice (Siobhan Fallon Hogan) about Edgar's (Vincent D'Onofrio) peculiar behaviour. These paper "Special Agent" ideas feature signatures for "T. Manheim" and "W. Black" handwritten in black ink and badge numbers "28407" and "70482" printed in red on their fronts with a fingerprint and the FBI director's signature on their reverses. Both come inside black leather cases. The cases exhibit minor cracking from production. Dimensions (each): 14 cm x 9.75 cm x 1.5 cm (5.5" x 3.75" x .5")

Estimate. £1,200 - 1,800



1161
Men in Black Stunt Fin Gun Ω
Men In Black II (2002)

A Men in Black stunt Fin Gun from Barry Sonnenfeld's sci-fi adventure sequel Men in Black II. Kay (as played by Tommy Lee Jones) took Jay (as played by Will Smith) and the Worm Guys to a secret Men in Black weapons stash in his old apartment which held Fin Guns. This otherworldly foam rubber stunt rifle is hand-painted silver-colour with black detailing on the grip, green slats on the butt, a slotted "fin" along the barrel, and two fibre cords on top. The gun exhibits scuffing throughout from production use, and some cracks in the foam from age. Dimensions: 57.25 cm x 19 cm x 9 cm (22.5" x 7.5" x 3.5")

Estimate. £1,000 - 1,500



1162
First Contact Alien Head Appliance Ω
Men In Black II (2002)

A First Contact alien head appliance from Barry Sonnenfeld's sci-fi action comedy sequel Men in Black II. First Contact aliens appeared throughout the franchise, including when Jay (Will Smith) walked through MIB headquarters. This foam latex appliance is ornately painted to appear scaly and reptilian by Rick Baker's Cinovation Studios. It is inset with black acrylic lenses, reinforced with power netting, and affixed with breathing tubes on the interior. The mask comes mounted with PVC pipe to a wood base affixed with a tag marked "Big Head Alien." The left lens is loose from production. Dimensions (displayed): 38 cm x 38 cm x 37 cm (15" x 15" x 14.5")

Estimate. £1,000 - 1,500



1163
Set of Three 1969 Alien Costumes Ω
Men In Black 3 (2012)

Three 1969 alien costumes from Barry Sonnenfeld's sci-fi action comedy sequel Men In Black 3. Agent J (Will Smith) encountered many alien species in MIB's 1969 Headquarters. This set consists of a Basketball Head alien costume featuring a maroon leatherette coat marked "Jay Sundell," pink silk scarf, metal necklace and shell pendant, and matching black leatherette gloves, elastic suspenders, cotton-blend pants, and leather shoes; a Twilight alien costume featuring a gold-colour nylon-blend jumpsuit and green iridescent tube details; and a First Contact alien costume featuring a copper-colour spandex-blend jumpsuit labelled "Daniel Mintz" with matching gauntlets, rubber Tretorn boots, and three "Daniel Mintz" production tags. The costumes exhibit staining, fading, cracking, and tearing.

Estimate. £800 - 1,200



1164
Ethan Hunt's (Tom Cruise) Team File M
Mission: Impossible - Fallout (2018)

Ethan Hunt's (Tom Cruise) team file from Christopher McQuarrie's action sequel Mission: Impossible - Fallout. IMF Secretary Alan Hunley (Alec Baldwin) handed Ethan Hunt (Tom Cruise) a file containing information about his team that suggested Hunt was the mysterious and villainous John Lark. The file includes photos and information about Hunt and his team: Ilsa Faust (Rebecca Ferguson), Benji Dunn (Simon Pegg) and Luther Stickell (Ving Rhames). It also includes additional letters and memos, some of which are highlighted and feature handwritten signatures. Dimensions: 30 cm x 24 cm x 1 cm (11 3/4" x 9 1/2" x 1/2")

Estimate. £3,000 - 5,000



1165
White Widow (Vanessa Kirby) File M
Mission: Impossible - Fallout (2018)

A White Widow (Vanessa Kirby) file from Christopher McQuarrie's action sequel Mission: Impossible - Fallout. IMF Secretary Alan Hunley (Alec Baldwin) handed Ethan Hunt (Tom Cruise) a file containing information and photos of Alanna Mitsopolis, aka White Widow, before Hunt was due to liaise with her. The file contains photos of Mitsopolis and her brother (Frederick Schmidt), as well as images of the rendezvous location. It also includes pages of information and redacted emails. Dimensions: 30 cm x 26 cm (11 3/4" x 10 1/4")

Estimate. £1,500 - 2,500



1166
August Walker's (Henry Cavill) Stunt Detonator Ω
Mission: Impossible - Fallout (2018)

August Walker's (Henry Cavill) stunt detonator from Christopher McQuarrie's action sequel Mission: Impossible - Fallout. In the climactic battle, Walker and Ethan Hunt (Tom Cruise) fought over a detonator which controlled two nuclear devices. This stunt detonator is made of cast hard rubber with an extended antenna, false buttons labelled "Arm/Disarm" and "Safe On," and a sticker reading "Time 15m 00s" which was digitally replaced in the finished film affixed to the timer display. It exhibits some wear from production use, including scuffing and several cracks in the loops at the top. Dimensions: 26.75 cm x 6.5 cm x 3 cm (10.5" x 2.5" x 1.25")

Estimate. £1,200 - 1,800

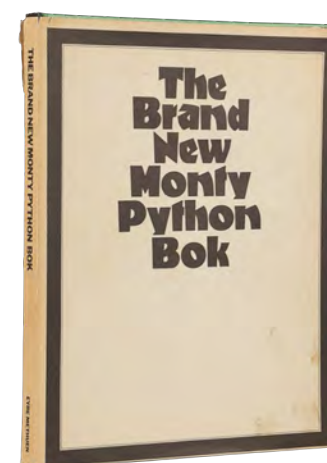

1168
Cast Autographed Edition of The Brand New Monty Python Bok M
Monty Python

A cast-autographed edition of The Brand New Monty Python Bok. The book comes in a white dust jacket with the title printed in black beside some realistic, smudged fingerprints on the front and the same title printed in reverse on the back. Underneath the dust jacket is a fake "Church Architecture" cover titled "Tits 'n Bum" with a background photo of several intertwined naked women. The book's first page features the autographs of Graham Chapman, John Cleese, Terry Gilliam, Eric Idle, Terry Jones and Michael Palin. These are positioned around a faux, glued-in Ferndean School library check-out page containing a list of all the students who withdrew the book, including "J.P. Sartre", "S. Davis Jr.", "Shirley Bassey" and "M. Thatcher". Also included is a black-and-white photograph of the comedy troupe. The dust jacket exhibits discolouration from age and small tears. Dimensions (book): 28.5 cm x 22.5 cm x 1.5 cm (11 1/4" x 8 1/4" x 1/2")

Estimate. £1,000 - 1,500

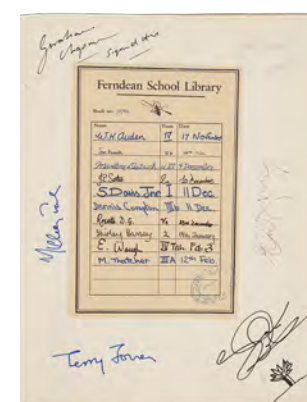

1167
Gray Widower Lighting Stand-in M
Mist, The (2007)

A grey widower lighting stand-in from the production of Frank Darabont's horror The Mist. Grey widowers were spider-like creatures which, along with other monsters appearing out of the mist, terrorised a group of people hiding in a supermarket. Lighting stand-ins are used to give special effects artists lighting references for the CGI creatures appearing in a film. The hand-painted creature has resin legs, a foam-rubber body and head, and wooden spines. It has some minor cracks in the foam rubber and is missing three fangs around the mouth. Dimensions: 27 cm x 38 cm x 17 cm (10 3/4" x 15" x 6 3/4")

Estimate. £1,500 - 2,500



1169
Rick O'Connell (Brendan Fraser) Costume +
Mummy, The (1999) And Mummy Returns, The (2001)

A Rick O'Connell (Brendan Fraser) costume from Stephen Sommers' fantasy-adventure The Mummy and its sequel The Mummy Returns. Rick wore his Foreign Legion jacket while defending the ruins of Hamunaptra from the Medjai at the beginning of The Mummy, and his shirt and trousers throughout much of The Mummy Returns. The jacket is labelled "Brendan Frazier [sic] April 1998"; the shirt is labelled "Stage 3 DBL"; and the trousers are labelled "Stunt Double Brendan Frazier [sic] April 2000". The costume pieces have been intentionally distressed to look well worn, with stains and holes.

Estimate. £1,000 - 1,500



1170
Set of Four Prototype Red Canopic Jars +
Mummy Returns, The (2001)

A set of four prototype red Canopic jars from the production of Stephen Sommers' action-adventure sequel *The Mummy Returns*. Canopic jars can be seen in the tomb explored by Rick (Brendan Fraser) and Evelyn (Rachel Weisz) at the beginning of the film. The jars are predominantly made of plaster, with an acrylic cylinder in each jar's base. They are painted red and feature hieroglyphs on the base, and each jar's lid represents a different animal. The paintwork is slightly different to the one seen in the film. The jars have been intentionally distressed to look ancient, but show some additional paint wear from age. Dimensions (tallest): 12 cm x 12 cm x 17 cm (4 3/4" x 4 3/4" x 6 3/4")

Estimate. £800 - 1,200



1172
Jim Henson Autographed Photo and Screening Ticket +
Great Muppet Caper, The (1981)

A Jim Henson-autographed photo and a screening ticket from the production of Henson's adventure comedy *The Great Muppet Caper*. The photograph shows Henson with several Muppets, including Kermit the Frog, and has been inscribed "To Sheala from Kermit the Frog and Jim Henson" in green ink. The ticket was issued for a unit screening of the film on Sunday 21 June 1981, at the Odeon cinema in Marble Arch, London. The ticket is marked as "No. 732". Dimensions (photograph): 20 cm x 25.5 cm (8" x 10")

Estimate. £400 - 600



1171
Gonzo's "Workin' at the Car Wash Blues" Morgan Car +
Muppet Show, The (T.V. Series, 1976-1981)

Gonzo's Morgan car from Jim Henson's comedy TV series *The Muppet Show*. Gonzo's car appeared during the opening number of Season 5 Episode 7. Gonzo sang "Workin' at the Car Wash Blues" as he cleaned the vehicle before driving off. The car also appeared in Season 5 Episode 10 where the car featured the number plate "ZZXKL", which led Fozzie and Link to believe the car's name was "Zikskuhl". The car is a small-scale pedal version of the Morgan Plus 8. It comprises a steel chassis with treadle-action drive to the rear axle; four wheels and a spare, with solid rubber tyres; a red fibreglass body; a black leather-lined seat; a clear plastic "aero" windscreen; a pair of functional headlights activated by a button by the steering wheel; an "LG10" number plate on the front bumper; and the loose "ZZXKL" number plate. Dimensions: 123 cm x 48 cm x 43 cm (48" x 19" x 17") Contains electronics; see electronics notice in the Buyer's Guide.

Estimate. £2,000 - 3,000



1173
Morgan Weistling Pencil Poster-concept Drawing +
Muppet Christmas Carol, The (1992)

A pencil poster-concept drawing from the promotion of Brian Henson's festive musical comedy *The Muppet Christmas Carol*. This concept artwork, which was ultimately unused, was hand-drawn by renowned artist Morgan Weistling. The drawing features Ebenezer Scrooge (Michael Caine) sitting in a chair surrounded by an array of Muppet characters, including Bob Cratchit (Kermit the Frog), Emily Cratchit (Miss Piggy), Charles Dickens (The Great Gonzo) and Tiny Tim Cratchit (Robin the Frog). The artwork is rendered on card, covered by a sheet of tracing paper that's secured with masking tape along the top edge. Weistling has signed the artwork. The lot exhibits signs of smudging. Dimensions: 33.5 cm x 24 cm (13 1/4" x 9 1/2") Sold without copyright; see copyright notice in the Buyer's Guide.

Estimate. £1,500 - 2,500



1174
Invisible Boy's (Kel Mitchell) Cape +
Mystery Men (1999)

Invisible Boy's (Kel Mitchell) cape from Kinka Usher's superhero comedy *Mystery Men*. Invisible Boy wore his cape when the Mystery Men went to Casanova Frankenstein's (Geoffery Rush) mansion. This costume consists of a layered canvas cape lined with black taffeta and printed with a city design, as well as a vest with its back directly sewn onto the cape. Black nylon straps with metal hardware sit at the cape's shoulders and metal studs decorate the side seams. Attached by hook and loop fasteners, the vest front is removable and features two black zippers and a centre front pocket. The costume exhibits some pilling from wear.

Estimate. £600 - 800



1176
Sheet of Four Roy Hobbs (Robert Redford) Baseball Cards +
Natural, The (1984)

A sheet of four Roy Hobbs (Robert Redford) baseball cards from Barry Levinson's sports drama *The Natural*. Sheets of vintage cards were printed out after baseball rookie Hobbs became a star player for the New York Knights. This uncut sheet of four glossy Playball-style "Roy Hobbs" cards is printed in full colour on cardstock with blue borders and text and an unmarked back. The top edge of the sheet exhibits creasing and bending from production. Dimensions: 12.75 cm x 16.5 cm (5" x 6.5")

Estimate. £400 - 600



1175
Burned John Wilkes Booth (Christian Camargo) Diary Page +
National Treasure: Book Of Secrets (2007)

A burned John Wilkes Booth (Christian Camargo) diary page from Jon Turteltaub's action-adventure sequel *National Treasure: Book of Secrets*. Mitch Wilkinson (Ed Harris) revealed a burned page from Booth's Diary to discredit Ben Gates' (Nicholas Cage) at his own seminar and provoke Gates to action. This paper page is intentionally distressed by production to appear aged, torn, and discoloured from being burned. It features calligraphic print referring to several of Booth's co-conspirators in the assassination of Abraham Lincoln, including "Surratt," "Spangler," "Payne," and a crossed-out "Thursday June 3 1864" date. The page exhibits fold lines from production. Dimensions: 7.75 cm x 10.25 cm (3" x 4")

Estimate. £2,000 - 3,000



1177
Geoff Portass' Personal First and Second Draft Scripts +
Nightbreed (1990)

Special make-up effects supervisor Geoff Portass's personal scripts from Clive Barker's fantasy horror *Nightbreed*. The script labelled "1st Draft" is dated "14th September 1988" and comprises 104 unannotated pages, with Geoff Portass' name and the issue name "34" handwritten along the top of the cover. Bound in a black card cover, the second draft script consists of 131 pages, with 18 assorted first draft upside-down pages located at the back. Portass' name and the number "70" are handwritten on the title page, and the document is dated "December, 1988". The card cover exhibits several tears, and the first draft's back page displays notable folds. Dimensions (larger script): 30.5 cm x 21.5 cm x 2 cm (12" x 8 1/2" x 3/4")

Estimate. £800 - 1,200



1178
Simon Bamford's Personal Shooting Script, Behind-the-scenes Photos and Ephemera M
Nightbreed (1990)

Simon Bamford's personal shooting script, behind-the-scenes photos and ephemera from the production of Clive Barker's fantasy horror Nightbreed. Bamford played Midian resident Ohnaka. Dated "December 1988", the 148-page, second-draft script is bound in black card with two metal butterfly pins and comes with 38 loose amendment pages. Also included in the lot are four continuity Polaroids featuring Bamford as Ohnaka; eight photographs of the make-up department at work; seven larger stills; a premiere invitation; a Nightbreed comic book; and assorted production paperwork. Completing the collection is a still of Ohnaka autographed by Bamford. There are notable rips on the script's card cover. Dimensions (script): 31 cm x 22 cm x 2 cm (12 1/4" x 8 3/4" x 3/4") Sold without copyright; see copyright notice in the Buyer's Guide.

Estimate. £800 - 1,200

1179
Plaster Freddy Krueger (Robert Englund) Rebirth Glove Casting Ω
A Nightmare On Elm Street 4: The Dream Master (1988)

A plaster Freddy Krueger (Robert Englund) rebirth glove casting from Renny Harlin's horror sequel A Nightmare on Elm Street 4: The Dream Master. Krueger's signature glove caught flame when his skeleton re-assembled itself in Ronald Kincaid's (Ken Sogoes) junkyard dream. This detailed plaster cast was created by R. Chris Biggs EFX Shop for a silicone mould used to fabricate Freddy's flammable glove. Also included is a Letter of Authenticity from SFX makeup artist Scott Coulter. The cast is unpainted and flattened on the bottom. Dimensions: 24.25 cm x 16.5 cm x 7.75 cm (9.5" x 6.5" x 3")

Estimate. £1,200 - 1,800

1180
Plaster Freddy Krueger (Robert Englund) Rebirth Head Casting Ω
A Nightmare On Elm Street 4: The Dream Master (1988)

A plaster Freddy Krueger (Robert Englund) rebirth head casting from Renny Harlin's horror sequel A Nightmare on Elm Street 4: The Dream Master. Krueger's skeleton was re-assembled in his junkyard grave during Ronald Kincaid's (Ken Sogoes) dream sequence. This cast, the first pour from the original alginate mould, was created by R. Chris Biggs EFX Shop for the silicon mould for the reborn Krueger's prosthetic makeup. Included is a Letter of Authenticity from SFX makeup artist Scott Coulter. The cast exhibits scuffing and a split in the ear where plaster entered the mould's seamline. Dimensions: 45.75 cm x 25.5 cm x 38.25 cm (18" x 10" x 15")

Estimate. £1,200 - 1,800



1.6 m (5.25')

1181
Large-scale Model Miniature Helicopter M
North Sea Hijack (1979)

A large-scale model miniature helicopter from Andrew V. McLaglen's action thriller North Sea Hijack. This model helicopter was used in place of a full-sized Bo 105 for SFX distance shots as it approached the oil rig platform that had been hijacked by terrorists. Made from wood and metal with a fibreglass shell, the helicopter is painted red with blue accents including the name of the craft "Jennifer" on the tail. This name is a reference to the book on which the film is based: Esther, Ruth, and Jennifer by Jack Davies. The model helicopter features mechanical propellers with a motor hidden behind the cockpit and shows minor paint wear from age. Dimensions: 160 cm x 60 cm x 45 cm (63" x 23 1/2" x 17 3/4") Special shipping required; see special shipping notice in the Buyer's Guide. Contains mechanical components; see mechanical notice in the Buyer's Guide.

Estimate. £3,000 - 5,000



1182
The Bank Casino Playing Cards, Chips, Plaques, Dice and Coin Ω
Ocean's Thirteen (2007)

Casino playing cards, chips, plaques, dice and a coin from Steven Soderbergh's heist-comedy sequel Ocean's Thirteen. Willy Bank (Al Pacino) owned and operated The Bank hotel and casino - the latest target of Danny Ocean (George Clooney) and his gang. This lot includes a pack of playing cards; eight sets of chips in varying denominations; four betting plaques; a set of five translucent green dice; and a golden \$1 coin. Each item features The Bank Casino name, and the chips come with a white plastic case for storage. Dimensions (each plaque): 5.5 cm x 8.5 cm (3 1/4" x 3 1/4"); (pack of cards): 9 cm x 6.5 cm x 1.5 cm (3 1/2" x 2 1/2" x 1/2")

Estimate. £1,000 - 1,500



1183
Set of Three BBFC Certificates M
Omen, The (1976) / Damien: Omen II (1978) / Omen III: The Final Conflict (1981)

A set of three original British Board of Film Classification certificates for Richard Donner's horror The Omen, Don Taylor's sequel Damien: Omen II, and Graham Baker's third instalment Omen III: The Final Conflict. These certificates were issued to state which age bracket each film was suitable for, and were shown in UK cinemas before the start of each movie. All three certificates display a red-and-black colour scheme and a rating of X. There are notable signs of wear to the top right corner of the Omen certificate. Dimensions (each certificate): 28 cm x 32.5 cm (11" x 12 3/4")

Estimate. £1,500 - 2,500

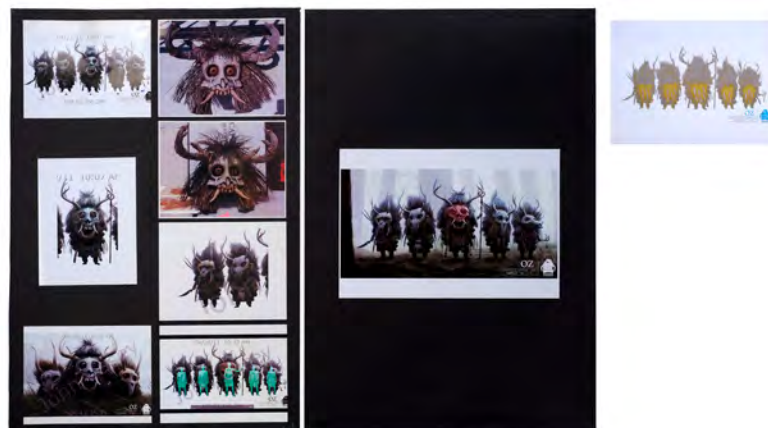

1184
Set of Nine Printed Whimsie Concept Artworks Ω
Oz The Great And Powerful (2013)

Nine printed Whimsie concept artworks from the production of Sam Raimi's fantasy prequel Oz the Great and Powerful. Whimsies - evil spirits who resided outside the Land of Oz - appeared in L. Frank Baum's Oz books, but ultimately did not appear in the film. These Whimsie concept designs were created and printed by specialty costuming firm Frontline Design during pre-production. The set features individual and group images printed on glossy colour Frontline Design stock and mounted to black construction paper. Five designs are labelled "Oz" and "Whimsie," and six are dated between March and April 2011. The lot exhibits minor creasing throughout from production. Dimensions: 63.5 cm x 94 cm (25" x 37")

Estimate. £400 - 600



1186
Leslie Knope's (Amy Poehler) Essential ID Lanyard Ω
Parks And Recreation (T.V. Series, 2009 - 2015)

Leslie Knope's (Amy Poehler) essential ID lanyard from the comedy series Parks and Recreation. In Season 3, Knope became an essential employee and gained the confidence to lead Pawnee's Parks and Recreation department. This plastic-laminated, colour-printed paper ID is labelled "Leslie Knope" and "Essential" alongside the City of Pawnee emblem, a barcode, and Knope's headshot and comes clipped to a woven navy blue lanyard. An Entertainment 720 sticker labelled "Props Do Not Remove" is affixed to the ID's back. It exhibits plastic bubbling at the upper right corner, and caught threads on the lanyard. Dimensions: 53.5 cm x 5.75 cm x 1.5 cm (21" x 2.25" x 0.5")

Estimate. £700 - 900



1185
Japanese Officer's Hero Katana and Scabbard \mathcal{M}
Pacific, The (T.V. Series, 2010)

A Japanese officer's hero katana and scabbard from the HBO war drama mini-series The Pacific. Japanese officers carried katanas both ceremonially and as a weapon for hand-to-hand combat. The katana is made from metal with woven leather on the handle and features a cherry blossom design on the tsuba (guard), fuchi (handle collar), menuki (handle ornament) and fuchi-kashira (end cap). The katana comes with a brown leather scabbard into which it locks in place when sheathed, and a button on the handle frees the blade when pressed. The blade is tarnished with stage blood, has a dulled edge, and some of the metal shows discolouration. Dimensions: 104 cm x 7.5 cm x 5.5 cm (41" x 3" x 2")

Estimate. £600 - 800



1187
Gina Gray's (Anya Taylor-Joy) Lighter \mathcal{M}
Peaky Blinders (T.V. Series, 2013-2022)

Gina Gray's (Anya Taylor-Joy) lighter from season six of the crime drama television series Peaky Blinders. Gina used her lighter after answering a call at her home which informed her that all the Shelby men will be gathering soon. She lit a cigarette as she told her husband Michael (Finn Cole) that the Shelby's would be by a window, meaning that their men could drive by and shoot Arthur Shelby (Paul Anderson). The lighter is made from brass with a marbled-orange plastic shell - it resembles a Dunhill and has an extinguishing arm and a screw to the side that raises the flame. On the base is the fuel screw and the engraving "PAT No. 143752 Made in England". Dimensions: 5 cm x 4.5 cm x 1 cm (2" x 1 3/4" x 1/4")

Estimate. £600 - 800



1188
Jud Crandall's (Fred Gwynne)
Costume \mathcal{M}
Pet Sematary (1989)

Jud Crandall's (Fred Gwynne) costume from Mary Lambert's adaptation of Stephen King's Pet Sematary. Jud wore his costume during the film's climax as the undead Gage Creed (Mike Hughes) returned home. The costume consists of a pair of striped bib overalls; a multi-coloured, canvas-like sweater and a taupe long sleeved undershirt (size XL). Each piece has been intentionally distressed with stage blood, dirt and stains.

Estimate. £3,000 - 5,000



1189
Captain Hook (Jason Isaacs)
Costume Design \mathcal{M}
Peter Pan (2003)

A costume design for Captain Hook (Jason Isaacs) from the production of P. J. Hogan's fantasy adventure film Peter Pan. Peter Pan (Jeremy Sumpter) led Wendy (Rachel Hurd-Wood), John (Harry Newell) and Michael (Freddie Popplewell) to Neverland, where they battled against the evil Captain Hook and his pirates. The detailed full-body concept illustration is printed with a combination of coloured pencil, paints, inks and markers applied over the top. It features a printed signature of credited concept artist Mariano Diaz and the artwork is dated "May 7, 2002". Multiple pinholes are present in the top corners of the paper. Dimensions: 76 cm x 54 cm (29 3/4" x 21 1/4") Sold without copyright; see copyright notice in the Buyer's Guide.

Estimate. £600 - 800



1190
The Phantom's (Gerard Butler)
Masquerade Stunt Sword and Mask Δ
Phantom Of The Opera, The (2004)

The Phantom's (Gerard Butler) stunt sword and mask from Joel Schumacher's film adaptation of The Phantom of the Opera. The Phantom wore his mask and wielded his sword after gatecrashing the masquerade ball held at the Opera House, where he demanded that the managers stage his new opera Don Juan. The sword, made of resin with inner metal supports, resembles a rapier and features an ominous skull as a crossguard. The sword is cast in the scabbard painted black and silver and shows minor paint wear and exposed metal from the removal of two prongs from the crossguard. The mask, made of fibreglass and resin, features a similar skull design with protruding brow and cheekbones. The inside of the mask is unfinished and there is no strap, indicating that it was not worn during shooting. Dimensions (sword): 114 cm x 16 cm x 12.5 cm (45" x 6 1/4" x 5"); (mask): 17.5 cm x 16.5 cm x 10 cm (7" x 6 1/2" x 4")

Estimate. £600 - 800

Donald Sutherland	Ridley Scott
Skye Bennett	Anatole Taubman
Natalia Wörner	Sam Claflin
Matthew Macfadyen	Rufus Sewell
Emily Holt	Eddie Redmayne



1191
Earl Bartholomew's (Donald Sutherland) Severed Head and Cast Chair Backs M
Pillars Of The Earth, The (T.V. Series, 2010)

Earl Bartholomew's (Donald Sutherland) severed head and a set of cast chair backs from the production of historical TV mini-series The Pillars of the Earth. Earl Bartholomew was executed in Episode 3 after being accused of plotting a rebellion against King Stephen (Tony Curran). The head is made of latex with a foam core. It features hand-punched hair and is painted in Sutherland's flesh tones, with blood red around the neck. The chair backs are made from polyester canvas and feature the names of cast members Donald Sutherland, Eddie Redmayne, Natalia Wörner, Rufus Sewell, Matthew Macfadyen, Skye Bennett, Emily Holt, Sam Claflin and Anatole Taubman, as well as producer Ridley Scott. Dimensions (severed head): 29 cm x 25 cm x 15 cm (11 1/2" x 10" x 6"); (chair back): 41 cm x 19 cm (16" x 7 1/2")

Estimate. £1,000 - 1,500



1194
General Ursus' (James Gregory) Stunt Pistol Ω
Beneath The Planet Of The Apes (1970)

General Ursus' (James Gregory) stunt pistol from Ted Post's sci-fi sequel Beneath the Planet of the Apes. General Ursus carried his gun, holstered at his hip, throughout the film. This stunt pistol is hand-painted black to resemble metal. Also included is a custom-made foam base painted beige to resemble stone, inset with two acrylic posts, and affixed with a plaque featuring the film's logo. The pistol exhibits extensive paint flaking and some cracks from production and age. Dimensions (displayed): 37 cm x 28 cm x 18 cm (14.5" x 11" x 7") Ownership may be restricted in some countries; see replica firearm notice in Buyer's Guide.

Estimate. £2,500 - 3,500



1192
Cursed Aztec Coin Ω
Pirates Of The Caribbean: The Curse Of The Black Pearl (2003)

A cursed Aztec coin from Gore Verbinski's adventure film Pirates of the Caribbean: The Curse of the Black Pearl. Stacks of coins filled the caverns of Isla De Muerta when Barbossa's (Geoffrey Rush) crew returned Aztec gold taken years earlier to finally lift their curse. This coin is made of metal with a gold-colour finish, gold-colour sparkles glued on for extra shine, a skull-and-sun motif engraved on front, and a geometric pattern engraved on back. It exhibits worn paint from production use. Dimensions: 0.75 cm x 0.75 cm x 0.25 cm (1.5" x 1.5" x 0.25")

Estimate. £2,500 - 3,500



1195
Mutant Mask Ω
Beneath The Planet Of The Apes (1970)

A mutant mask from Ted Post's dystopian sci-fi sequel Beneath the Planet of the Apes. Telepathic mutants deformed by nuclear radiation lived in the ruins of New York. Designed by creative makeup designer John Chambers and makeup supervisor Dan Striepeke from concepts by Post and screenwriter Paul Dehn, this foam latex mask is hand-painted in shades of pink and brown to resemble flesh and muscle with blue and red varicose veins, enlarged ears, and mouth and eyeholes. The mask comes mounted to a styrofoam bust for stability, but remains fragile and exhibits extensive stiffening, cracking, and tearing to the foam from age and wear. It should be handled with caution.

Estimate. £2,000 - 3,000



1193
Captain Jack Sparrow's (Johnny Depp) Chair Back M
Pirates Of The Caribbean: Dead Men Tell No Tales (2017)

Captain Jack Sparrow's (Johnny Depp) chair back from the production of Joachim Rønning and Espen Sandberg's swashbuckling sequel Pirates of the Caribbean: Dead Men Tell No Tales. Cast and crew use distinctive 'director's chairs' on set when resting between takes. The black canvas chair back features the text "Captain Jack Sparrow" on one side and the film title on the reverse, all printed in white. There are some minor marks present on one side and a fold line from previous storage. Dimensions: 54.5 cm x 16.5 cm x 1 cm (21 1/2" x 6 1/2" x 1/2")

Estimate. £600 - 800



1196
Cornelius' (Roddy McDowall) Astro Boots Ω
Escape From The Planet Of The Apes

Cornelius' (Roddy McDowall) Astro boots from Don Taylor's science fiction film sequel Escape from the Planet of the Apes. Cornelius wore futuristic astro boots when he landed on Earth. These zip-front Crown Bristolite boots (US size Large) are made of leather, rubber, foam, metal, and other assorted fabrics painted white. Also included is a custom-made foam display base painted beige to resemble stone and affixed with a plaque featuring the film's logo. The boots exhibit extensive cracking along the leather and loose rubber portions from production wear and age. Dimensions (displayed): 42 cm x 33.25 cm x 34.5 cm (16.5" x 13" x 13.5")

Estimate. £3,000 - 5,000



1197
Ape Army Rifle Ω
Planet Of The Apes (T.V. Series, 1974)

An ape army rifle from the sci-fi television series Planet of the Apes. The ape military used rifles in various scenes throughout the series. The rifle is carved from wood, stained dark brown. It features sculpted metal based on an M1 Carbine with a bulkier barrel and no magazine. It has a black-painted canvas shoulder strap affixed to metal loops. Dimensions: 88 cm x 14 cm x 7 cm (34 3/4" x 5 1/2" x 2 3/4")

Estimate. £1,000 - 1,500

1198
Ape Soldier Costume and Mask Ω
Planet Of The Apes (2001)

An ape soldier costume and mask from Tim Burton's sci-fi remake Planet of the Apes. Ape soldiers were notably seen following General Thade (Tim Roth) and Colonel Attar (Michael Clarke Duncan) during the final battle. This mask was created by renowned special effects artist Rick Baker, who designed and created all of the film's prosthetic makeup. The costume comprises a crimson, pointed urethane helmet; a foam-latex gorilla mask; a black neck bib; a set of red fibreglass chest armour with attached woven leather sleeves; a textured woollen long-sleeved top; a padded upper-body muscle leotard; a navy spandex full-body suit; a pair of gloves with ape-like fingers attached; a pair of black faux-leather hand covers; a patterned waist wrap; a pair of textured woollen trousers; a pair of red fibreglass shin guards; a pair of lace-up check-patterned boots with exposed ape toe appliances; and a stunt bolas throwing weapon. Multiple components feature labelled background/stunt actor names. The foam latex has crumbled away in places on the mask's interior.

Estimate. £3,000 - 5,000



1199
Three "Believe" Tickets Ω
Polar Express, The (2004)

Three train tickets from Robert Zemeckis' animated adventure film The Polar Express. Tickets were carried by children who travelled aboard the Polar Express, and had to be punched by the Conductor (Tom Hanks). Physical props were created for the film and used by motion-captured, live-performing actors. The actors and props were then overlaid with computer-generated 3D models. The lot comprises one large ticket and two smaller tickets, all made of card and numbered "0001225". All the tickets display an image of the train on one side, and the words "Round Trip" on the other. The word "Believe" - which featured on the Hero Boy's (also Hanks) ticket - is printed on both sides, as if it has been punched into the ticket. Dimensions (large ticket): 7 cm x 19 cm x 0.2 cm (2 3/4" x 7 1/2" x 1/4")

Estimate. £3,000 - 5,000



1200
Train Engineer (Michael Jeter) Striped Cap Ω
Polar Express, The (2004)

A train engineer (Michael Jeter) striped cap from Robert Zemeckis' animated adventure film The Polar Express. Smokey and Steamer, the fireman and engineer of the Polar Express (both played by Jeter), wore striped hats as they worked tirelessly to prevent the train from crashing. Physical props and costume components were used by live-performing actors, who dressed in Lycra suits covered in sensors for the purposes of motion capture. The actors and the props they held were then overlaid with computer-generated 3D models. The blue-and-white striped peaked cap features a round embroidered patch at the front, with the letters "PE" attached. The hat has been intentionally distressed with dirt stains and marks.

Estimate. £2,000 - 3,000

1202
The Hobo's (Tom Hanks) Motion Capture Coffee Pot Ω
Polar Express, The (2004)

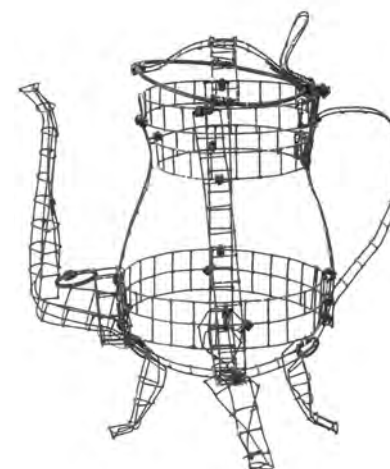

The Hobo's (Tom Hanks) motion capture coffee pot from Robert Zemeckis' animated adventure film The Polar Express. The Hobo prepared coffee over a fire and offered Hero Boy (also Hanks) a "cup of Joe" on the train's roof. Physical props and costume components were used by live-performing actors, who dressed in Lycra suits covered in sensors for the purposes of motion capture. The actors and the props they held were then overlaid with computer-generated 3D models. Several props were made from wire or mesh so the motion capture cameras could still read the sensor-marker dots on the actor. Made of sculpted thin black wire, the coffee pot features an opening lid, a handle, and a narrow spout and sits on four legs. Dimensions: 20 cm x 15 cm x 24 cm (8" x 5 3/4" x 9 1/2")

Estimate. £1,000 - 1,500



1201
Robert Zemeckis, Tom Hanks and Cast Chair Backs Ω
Polar Express, The (2004)

A set of three chair backs from the production of Robert Zemeckis' animated adventure film The Polar Express. Cast and crew use distinctive 'director's chairs' on set when resting between takes. All three are made of thick navy canvas and display the film title with an image of a jingle bell featuring a reflection of the train. On the reverse, two of the chair backs feature the names of director Robert Zemeckis and main cast member Tom Hanks, while the third displays the word "Cast", all printed in white and grey. The lot exhibits some minor stains and marks from use. Dimensions (each): 17 cm x 55 cm x 0.5 cm (6 3/4" x 21 1/2" x 1/4")

Estimate. £1,000 - 1,500

1203
Stand-In Large Punch Puppet Ω
Polar Express, The (2004)



A stand-in punch puppet from Robert Zemeckis' animated adventure film The Polar Express. Hero Boy played with a punch puppet on Christmas morning when his younger sister Sarah handed him a present containing his lost bell from Santa. Physical props were used by live-performing actors, who dressed in Lycra suits covered in sensors for the purposes of motion capture. The actors and the props they held were then overlaid with computer-generated 3D models. The puppet features a resin head, painted wooden hands and legs, and is dressed in a deep red velvet costume decorated with gold-coloured trim. The lot comes on a custom-made display featuring the film title. Dimensions (displayed): 30.5 cm x 30 cm x 72 cm (12" x 11 3/4" x 28 1/4")

Estimate. £600 - 800



1204
 Prototype Jingle Bell and Crew Gift Jingle Bell Ω
Polar Express, The (2004)

A prototype jingle bell and crew gift jingle bell from the production of Robert Zemeckis' animated adventure film The Polar Express. Only children who truly believed in Santa Claus heard the ringing of the bells, and Santa gifted the Hero Boy a bell. The prototype bell is made of brass, and the crew gift metal bell is decorated with engraved text reading "The Polar Express, 2003" and is attached to a strip of dark red leather. It comes in a navy velvet drawstring pouch which contains a thank you note from the film's producers. The prototype bell exhibits signs of verdigris patina. Dimensions (prototype): 4 cm x 4 cm x 5 cm (1 1/2" x 1 1/2" x 2"); (crew gift): 5 cm x 5 cm x 18 cm (2" x 2" x 7")

Estimate. £600 - 800



1205
 Open-Mouthed Vampire Maquette Display Ω
Priest (2011)

An open-mouthed vampire maquette display from the production of Scott Stewart's horror thriller Priest. Priest (Paul Bettany) and Priestess (Maggie Q) incinerated a trainload of vampires while rescuing Priest's kidnapped daughter, Lucy (Lily Collins). This reference maquette for a vampire with an open, fanged mouth is constructed from textured, translucent fibreglass with silicone skin painted to appear decayed on the rib cage, shoulder, and mouth. The maquette comes mounted to a foam-padded wooden display with the film's logo printed on the top. Several fangs are broken and the silicone is peeling off from exposure and age. Dimensions: 18 cm x 14 cm x 30.5 cm (7" x 5.5" x 12")

Estimate. £400 - 600

1206
 "When You Believe" Early Draft M
Prince Of Egypt, The (1998)

An early draft of the song "When You Believe" for the production of Brenda Chapman, Simon Wells and Steve Hickner's animated musical The Prince of Egypt. This song is the film's closing number and became a commercially successful single performed by Mariah Carey and Whitney Houston, winning Best Original Song at the 71st Academy Awards. The lyrics are handwritten in pencil on a page taken from a notepad and feature amendments and notes on the reverse side. The draft displays composer Stephen Schwartz's signature and the date "23 June 2000" written in purple pen at the bottom. The page exhibits grease stains and creased corners. Dimensions: 26.5 cm x 21 cm (10 1/2" x 8 1/4") Sold without copyright; see copyright notice in the Buyer's Guide.

Estimate. £600 - 800

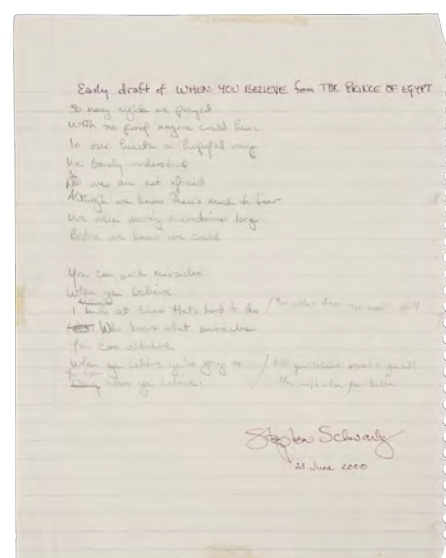

1207
 Dr. Elizabeth Shaw's (Noomi Rapace) Stunt and Hero Axes M
Prometheus (2012)

Dr. Elizabeth Shaw's (Noomi Rapace) stunt and hero axes from Ridley Scott's sci-fi prequel Prometheus. Shaw armed herself with an axe as she boarded the crashed lifeboat and discovered her alien progeny had grown to massive size. Shaw can be seen battling with the xenomorph with her axe in a deleted scene in the film. The lot features a hero axe with a steel head and resin handle, and a stunt axe made of rubber with a metal armature. Both have been intentionally distressed. The steel axe head has some rust and the foam rubber has some cracks. Dimensions (each): 93 cm x 7 cm x 30 cm (36 1/2" x 2 3/4" x 11 3/4")

Estimate. £3,000 - 5,000



1208
 SFX Escape Pod Δ
Prometheus (2012)

An SFX escape pod from Ridley Scott's sci-fi prequel Prometheus. Several escape pods were present in the bay of the Prometheus as Meredith Vickers (Charlize Theron) frantically changed into her spacesuit and strapped herself into her pod, before Captain Janek (Idris Elba) rammed the Engineer's ship. This version of the pod was created for exterior shots only. The pod is made of fibreglass finished in grey and silver, with a removable top panel featuring a transparent plastic viewport and black rubber trim. "Light Weight 1" and "1 x 450" are handwritten on the hollow interior. The lot displays notable scratching and scuffs on the underside. Dimensions: 253 cm x 126 cm x 76 cm (99 1/2" x 49 1/2" x 30") Special shipping required; see special shipping notice in the Buyer's Guide.

Estimate. £3,000 - 5,000



1209
 Prometheus Light-up Sleep Pod Δ
Prometheus (2012)

A light-up sleep pod from Ridley Scott's sci-fi prequel Prometheus. The Prometheus' crew journeyed to the moon LV-223 in sleep pods. Numbered "P-04", this resin pod features an MDF-and-fibreglass frame, a retractable upper panel, and clear acrylic casing. Its interior is lined with futuristic resin and metal components, and its base is lined with flexible plastic mesh. Electronics, including light-up control panels, buttons, white LED strip lights, and computer consoles, are installed internally and externally. The pod is finished in white and applied with an array of Weyland Corp. decals, safety warnings, and numbers. Its panel base exhibits cracking on both sides, and the frontal video screen is no longer present. Dimensions: 250 cm x 90 cm x 140 cm (98 1/2" x 35 1/2" x 55") Contains electronics; see electronics notice in the Buyer's Guide. Special shipping required; see special shipping notice in the Buyer's Guide.

Estimate. £3,000 - 5,000



1210
SFX Engineer Ampule M
Prometheus (2012)

An SFX Engineer ampule from Ridley Scott's sci-fi prequel Prometheus. The Prometheus crew found cavernous rooms filled with ampules containing terraforming biochemicals. This is one of 12 large-sized ampules made for the scenes in which the containers leaked their chemicals. This resin version has internal fluid lines to allow the flow of the black liquid, which runs through a hole at the base. For SFX use, a modified lid with a recessed top allowed for a pool of the fluid to sit while a speaker, previously installed within, animated it harmonically. Each ampule was intentionally distressed, with black traces of fluid still present down the sides. A standard version of the ampule's lid is included with the piece. Dimensions: 77 cm x 28 cm x 28 cm (30 1/4" x 11" x 11")

Estimate. £2,000 - 3,000



1212
Ceramic Engineer Ampule M
Prometheus (2012)

A ceramic Engineer ampule from Ridley Scott's sci-fi prequel Prometheus. Ampules were used by the Engineers to store their terraforming biochemicals, which were unstable at room temperature. The crew of the Prometheus found cavernous rooms filled with ampules of different sizes. Designed by raku pottery specialist Rob Sollis, this version of the deadly bioweapon is ceramic. It has alien text vertically etched into its curving body and is finished with metallic paint. The ampule comprises two separate parts - a lid and base - which have been intentionally distressed to appear ancient. There is a small chip on one side of the base opening. Dimensions: 17.5 cm x 17.5 cm x 42.5 cm (7" x 7" x 16 3/4")

Estimate. £2,000 - 3,000



1211
Engineer SFX Wax Head M
Prometheus (2012)

A wax Engineer head from Ridley Scott's sci-fi prequel Prometheus. The crew of the Prometheus discovered the head of an Engineer in the submerged alien structure on the moon LV-223 but it exploded when they tried to reanimate it. This hollow head is made of reinforced wax and has been intentionally distressed, giving the appearance of cracked and flaking skin. It was created for the 'exploding head' shot in the laboratory scene but ultimately wasn't required for filming. Dimensions: 35 cm x 26 cm x 21 cm (13 3/4" x 10 1/4" x 8 1/4")

Estimate. £2,000 - 3,000



1213
Prometheus Bridge Chair TD
Prometheus (2012)

A Prometheus bridge control chair from Ridley Scott's sci-fi prequel Prometheus. Captain Janek (Idris Elba), Dr. Elizabeth Shaw (Noomi Rapace) and others strapped themselves into their bridge chairs while the scientific ship Prometheus landed on the moon LV-223. The chair is made of fibreglass around a metal skeleton, and features a green padded seat and headrest, with a four-point harness which clips across the chest. The chair is intentionally distressed to appear well-used and is decorated with decals and stickers. It has some additional cracks and holes in the fibreglass. Dimensions: 75 cm x 64 cm x 135 cm (29 1/2" x 25 1/4" x 53 1/4") Special shipping required; see special shipping notice in the Buyer's Guide.

Estimate. £2,000 - 3,000



1214
Torch and "Pup" Scanner Ball M
Prometheus (2012)

A torch and "pup" scanner ball from Ridley Scott's sci-fi prequel Prometheus. The crew of the Prometheus used torches, and Fifield (Sean Harris) released his scanning "pups" while exploring the submerged alien structure on the moon LV-223. The metal torch lights up when powered with an AA battery and also features a red laser. The scanner is made of dense rubber and is painted to look like metal. Dimensions (torch): 21.5 cm x 3 cm x 3 cm (8 1/2" x 1 1/4" x 1 1/4"); (scanner): 9.5 cm x 9.5 cm x 9.5 cm (3 3/4" x 3 3/4" x 3 3/4") Contains electronics; see electronics notice in the Buyer's Guide.

Estimate. £1,000 - 1,500



1216
Pack of Red Apple Cigarettes M
Pulp Fiction (1994)

A pack of Red Apple cigarettes from Quentin Tarantino's neo-noir film Pulp Fiction. Several characters smoked Red Apples throughout the film, including Mia Wallace (Uma Thurman), Butch (Bruce Willis) and Pumpkin (Tim Roth). Red Apple is a fictional brand of cigarette that has featured in several Tarantino films, including Kill Bill: Vol. 1, The Hateful Eight and Once Upon a Time in Hollywood. This unopened packet is wrapped in clear plastic and features the graphic of a smiling green caterpillar emerging from a red apple and smoking a cigarette. Dimensions: 9 cm x 5.5 cm x 2.5 cm (3 1/2" x 2 1/4" x 1")

Estimate. £1,500 - 2,500



1215
Pack of Red Apple Cigarettes M
Pulp Fiction (1994)

A Red Apple cigarette pack from Quentin Tarantino's neo-noir movie Pulp Fiction. Several characters smoked Red Apples throughout the film, including Mia Wallace (Uma Thurman), Butch (Bruce Willis) and Pumpkin (Tim Roth). Red Apple is a fictional brand of cigarette that has featured in several Tarantino films, including Kill Bill: Vol. 1, The Hateful Eight and Once Upon a Time in Hollywood. The unopened packet is wrapped in clear plastic and features the graphic of a smiling green worm protruding from a red apple and smoking a cigarette. Dimensions: 8.5 cm x 5.5 cm x 2 cm (3 1/4" x 2 1/4" x 3/4")

Estimate. £1,500 - 2,500



1217
Pinhead and Blade Puppet Clothing O
Puppet Master Vs Demonic Toys (2004)

Pinhead and Blade's puppet clothing from Ted Nicolaou's cult horror crossover Puppet Master vs Demonic Toys. Pinhead and Blade are two characters created by Charles Band and David Schmoeller, and have appeared in several of their films. Pinhead's clothing comprises a pair of faux-suede trousers and a red jumper with the sleeves burnt off to reveal his powerful animatronic arms. Blade's clothing comprises a pair of polyester black trousers; a coat with battle-damaged sleeves and a faux-velvet collar; and an SFX blood-letting hook. Dimensions (hook): 23.5 cm x 5 cm x 4.5 cm (9 1/4" x 2" x 1 3/4")

Estimate. £1,000 - 1,500



1218
 Charles Babbitt's (Tom Cruise) Screen-matched
 Sports Jacket M
Rain Man (1988)

Charles "Charlie" Babbitt's (Tom Cruise) screen-matched sports jacket from Barry Levinson's Oscar®-winning drama Rain Man. Babbitt wore the jacket when he visited Wallbrook mental institution and met his brother Raymond "Ray" Babbitt (Dustin Hoffman), and when he accompanied Raymond to the train station in the closing sequence. The jacket screen-matches the one on screen in the placement of the bobble stitches and how the running stitches meet the collar and lapel seams. Made in Italy, the navy blue Bobby Yosten sports jacket is single-breasted with a slubbed linen blend and a low 2-button stance. The jacket exhibits a windowpane style; a white and orange check pattern; notch lapels; a welted breast pocket; straight jetted hip pockets; 3-button cuffs; and a ventless back.

Estimate. £3,000 - 5,000



1219
 John Rambo's (Sylvester Stallone) M60 Ammo Belt Ω
Rambo: First Blood Part II (1985)

John Rambo's (Sylvester Stallone) M60 ammo belt from George P. Cosmatos' action sequel Rambo: First Blood Part II. Rambo wore his M60 ammo belt in scenes where he carried his M60 machine gun, including when he attempted to free prisoners-of-war from a bamboo cage. This belt originated from Sylvester Stallone's personal collection. It consists of 57 real-world, non-firing military surplus M60 machine gun bullets. The bullets exhibit light tarnishing and discoloration from age and production use.

Estimate. £2,500 - 3,500

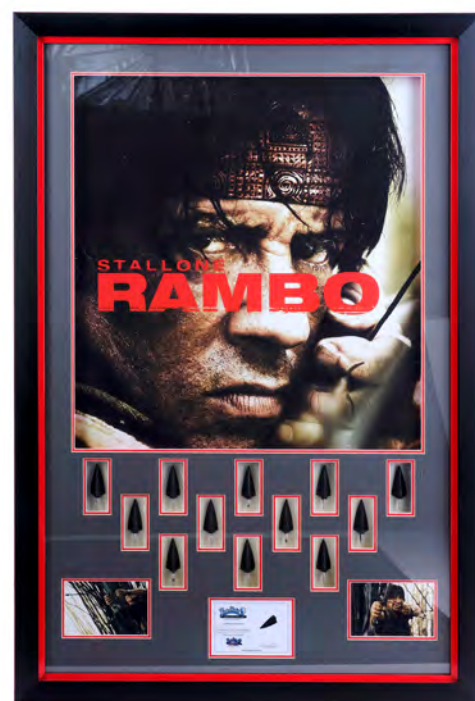

1220
 John Rambo's (Sylvester Stallone) Arrowheads
 Framed Display Ω
Rambo (2008)

A framed display of John Rambo's (Sylvester Stallone) arrowheads from Sylvester Stallone's action film Rambo. Rambo used his bow and arrows alongside the mercenaries to save missionaries. This lot consists of 12 arrowheads in a framed display. These unfinished arrowheads were originally created for the production. They are constructed of black rubber and feature three sides that come to a soft point, and a small threaded metal post at the base. This lot exhibits rough edges on the arrowheads and incomplete threading on the metal posts. Dimensions: 81.5 cm x 122 cm x 2.75 cm (32" x 48" x 1")

Estimate. £1,000 - 1,500



1221
 John Rambo's (Sylvester Stallone) Battle-Damaged
 Costume Ω
Rambo (2008)

John Rambo's (Sylvester Stallone) battle-damaged costume from Sylvester Stallone's action sequel Rambo. Rambo wore his costume throughout the film as he fought to save mercenaries from Major Pa Tee Tint's (Maung Maung Khin) forces. This costume consists of a dark brown cotton T-shirt (size XL) and stone-washed dark grey cotton GAP cargo jeans (size M). The trousers feature six pockets, including utility pockets on the front leg, and brass rivets on the ankles. The costume is extensively distressed by production to look battle-damaged with holes at the neck and sleeves.

Estimate. £2,000 - 3,000



1222
 John Rambo's (Sylvester Stallone) Stunt "Heartstopper"
 Knife Ω
Rambo: Last Blood (2019)

John Rambo's (Sylvester Stallone) stunt "Heartstopper" knife from Adrian Grunberg's action sequel Rambo: Last Blood. To avenge Gabriela (Yvette Monreal), Rambo cut out Hugo's (Sergio Peris-Mencheta) heart with his MK-9 sub-hilt tactical knife. Designed by knife designer Dietmar Pohl and nicknamed the "Heartstopper" by Stallone, this foam stunt knife is painted gunmetal grey and taupe with a handguard designed to look machined, handle scales, and an extended sub-hilt for control. A brown camouflage-patterned paracord is looped through the pointed pommel. The foam exhibits some pitting foam and the blade is nicked from production. Dimensions: 38.25 cm x 10.25 cm x 3.25 cm (15" x 4" x 1.25")

Estimate. £2,500 - 3,500



1223
 Baby Skutter M
Red Dwarf (T.V. Series, 1988 - 2022)

A baby Skutter from the sci-fi comedy television show Red Dwarf. Skutters were motorised service droids on the Red Dwarf and one had babies with a female version aboard the alternate Red Dwarf in "Parallel Universe", the sixth episode of Series II. The skutter is made of plastic and resin around a biscuit-foam core. It is painted metallic blue and numbered "56". The skutter has a short section of fishing line at the back and a small hole in the front, where it was dragged along behind the larger Skutter. There are some minor chips and cracks, and the base is slightly loose. Dimensions: 13.5 cm x 8 cm x 12 cm (5 1/4" x 3 1/4" x 4 3/4")

Estimate. £1,000 - 1,500



1224
The Tin Man's (Deep Roy) Head Plaque †Δ
Return To Oz (1985)

The Tin Man's (Deep Roy) head plaque from Walter Murch's fantasy-adventure sequel Return to Oz. After the defeat of the Nome King (Nicol Williamson), the Tin Man was no longer petrified and reunited with Dorothy (Fairuza Balk) and her friends in a celebratory parade. A plaque adorned the right side of the Tin Man's hat. The plaque is made of metal finished in a copper colour and features raised lettering, which reads "Baum Hardware Co., Fine funnels for Kerosene, Gasoline & Coal Oil". There are four screw holes, and the plaque is curved in shape, allowing it to be attached flush to the hat. There are several marks present on the lot. Dimensions: 6 cm x 12 cm x 2 cm (2 ¼" x 4 ¾" x ¾")

Estimate. £3,000 - 5,000



1225
Tik-Tok Crew Gift and Compliment Slip †M
Return To Oz (1985)

A Tik-Tok crew gift and compliment slip from the production of Walter Murch's fantasy-adventure sequel Return to Oz. This miniature mechanical figure is made of gold-colour metal and features intricate detailing, including a moustache, a tin helmet, and rivets around its rotund torso. Small screws allow the model's arms to move backwards and forwards. Also included in the lot is an Oz Productions Limited compliment slip. Presented in its original box, the crew gift exhibits light scratching and patches of wear to the gold finish, and the compliment slip is creased. Dimensions (crew gift): 4 cm x 5.5 cm x 7 cm (1.5" x 2.25" x 2.75")

Estimate. £800 - 1,200

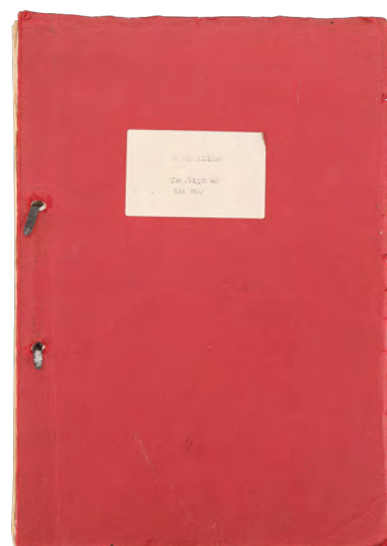

1226
Storyboard Binder †M
Return To Oz (1985)

A storyboard binder from the production of Walter Murch's fantasy-adventure sequel Return to Oz. The set comprises 266 printed storyboards split into four sections, each featuring a red or yellow-coloured card cover with a label displaying "Oz Productions" and a brief scene reference. The storyboards depict several scenes, including The Gump coming to life and flying across the Deadly Desert; and Dorothy's (Fairuza Balk) meeting with the Nome King (Nicol Williamson). The name of credited executive producer Gary Kurtz is written on the yellow card cover, and the binder's spine is labelled "02 Storyboard, Dorothy Meets The Nome King". There are signs of foxing on some sheets. Dimensions: 30.5 cm x 21.5 cm x 4 cm (12" x 8 ½" x 1 ½")

Estimate. £600 - 800



1227
Peter Sellers Life Casts †Δ
Revenge Of The Pink Panther (1978)

A pair of Peter Sellers life casts from the production of Blake Edwards' crime-comedy sequel Revenge of the Pink Panther. Life casts are often made on productions to test prosthetics and make-up. Inspector Clouseau (Peter Sellers) was a master of disguise, so required multiple make-up and costume changes. The casts are made of plaster and vary slightly, with one featuring an elongated nose and wrinkles. "Mafia" is carved into the forehead of the other, for the scene in which Clouseau disguised himself as a Mafia don. The casts both feature a build-up of grime and dust, and small chips. One has a small dried patch of clay on the forehead. Dimensions (each cast): 35 cm x 18 cm x 13 cm (13 ¾" x 7" x 5")

Estimate. £600 - 800



1228
Caesar's (Andy Serkis) Cattle Prod and Cord Ω
Rise Of The Planet Of The Apes (2011)

Caesar's (Andy Serkis) cattle prod and cord from Rupert Wyatt's sci-fi film Rise of the Planet of the Apes. Caesar wielded his cattle prod against Dodge Landon (Tom Felton) before he freed other apes from their cages. This lot consists of a metal cattle prod designed by SPFX Coordinator Tony Lazarowich. Designed to produce sparks, it features a round, two-prong cap with a leather-wrapped handle and an attached black paracord. Also attached is a four-foot long cable. Production intentionally distressed the prod. This lot exhibits rusting, scuffing, and scratched paint from production. Dimensions: 167.75 cm x 5.25 cm x 5.25 cm (65.75" x 2" x 2") Contains electronic components; see notice in the Buyer's Guide.

Estimate. £3,000 - 5,000



1229
EM-208 Droid †M
Robocop (2014)

An EM-208 droid from José Padilha's sci-fi action remake RoboCop. EM-208 droids were purely robotic drones created by OmniCorp to replace police and military personnel. Rows of droid parts could be seen hanging from the ceiling when Alex Murphy (Joel Kinnaman) tried to escape the OmniCorp labs. The droid has a black resin torso and a silver, 3D-printed head. The torso features metal cords to the left and right of the head, allowing it to be hung. The droid sits on a custom-made display with the film's title on the base. Dimensions (display): 31 cm x 39 cm x 107 cm (12 ¼" x 15 ¼" x 42 ¼")

Estimate. £1,000 - 1,500



1230
 Richie Lanz's (Bill Murray) Star Motel Management Costume Ω
Rock The Kasbah (2015)

Richie Lanz's (Bill Murray) Star Motel management costume from Barry Levinson's comedy *Rock the Kasbah*. Richie wore his costume when he auditioned and signed a client from his motel room office. This costume consists of a brown leather Reed Sportswear jacket; a patterned blue cotton Billy Reid button-up shirt (US size L); a white cotton Zimmerli undershirt; blue Levi's jeans; brown leather To Boot New York ankle boots (US size 12); a floral-patterned brown leather belt; a puka shell necklace; a metal bracelet; and a wardrobe tag hand-labelled "Richie" and "Hero Siler [sic] Bracelet." The leather components exhibit cracking from use and age.

Estimate. £800 - 1,200



1231
 Merci's (Kate Hudson) Denim Costume Ω
Rock The Kasbah (2015)

Merci's (Kate Hudson) denim costume from Barry Levinson's music comedy *Rock the Kasbah*. Merci wore her costume when she celebrated Salima's (Leem Lubany) Afghan Star Top 3 win. This costume consists of a blue denim zip-up jumpsuit; a sheer light blue shawl with gold-colour tassels and floral pattern details; a pair of faux gold hoop earrings; five faux gold rings; a metal chain necklace with a heart-shaped pendant; a faux gold-and-turquoise bracelet; two black leather and plastic high-heeled shoes; and a blue denim purse with faux gold and plastic gem details. Also included are five wardrobe tags hand-marked "Merci." The jumpsuit is intentionally distressed with holes by production, and the shawl exhibits some fraying.

Estimate. £500 - 700

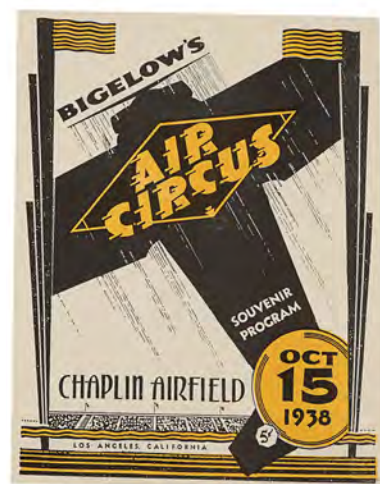

1232
 Bigelow's Air Circus Programme, Set of Badges and Headed Paper μ
Rocketeer, The (1991)

A Bigelow's Air Circus programme, a set of badges and a sheet of headed paper from Joe Johnston's action-adventure film *The Rocketeer*. Crowd members held branded memorabilia and staff members wore badges at Bigelow's Air Circus, where stunt pilot Cliff (Bill Campbell) donned his *Rocketeer* pack. The lot consists of a paper Bigelow's Air Circus souvenir programme; a Bigelow's Air Circus logo white badge; a white "Judge" badge; a gold-coloured badge featuring an image of a plane; and a sheet of Bigelow's letterhead paper. Dimensions (programme): 28 cm x 21.5 cm (11" x 8 1/2"); (each pin): 5.5 cm x 5.5 cm x 1 cm (2 1/4" x 2 1/4" x 1/2"); (paper): 28 cm x 21.5 cm (11" x 8 1/2")

Estimate. £300 - 500



1233
 Elton John's "Bennie and the Jets" Cane Δ
Rocketman (2019)

Elton John's "Bennie and the Jets" cane from Paramount Pictures' biographical musical *Rocketman*. Elton held his cane as he walked down a staircase into a nightclub in a hallucinogenic drugged state during the "Bennie and the Jets" montage, which began with him performing the song on stage.

The cane consists of a clear, spherical faux-crystal handle, a gold-coloured metal collar and a black-painted wooden shaft with a black rubber ferrule attached to its tip. Dimensions: 93 cm x 5 cm x 5 cm (36 1/2" x 2" x 2")

Estimate. £1,500 - 2,500



1234
 Elton John's Miniature Mansion Δ
Rocketman (2019)

Elton John's miniature mansion from Paramount Pictures' biographical musical *Rocketman*. At the end of a sequence charting Elton's rise to fame, he and John Reid opened the front of a miniature mansion to reveal a golden Goodbye Yellow Brick Road record.

Based on the Brocket Hall estate, this miniature mansion features detailed wood and resin brickwork, tiling and chimneys, with acrylic exterior windows. The front opens on metal hinges revealing six small rooms and a central chamber lined with detailed portraits. Each room displays paper floor tiling, felt rugs and white miniature furniture. It also features wired ceiling LEDs, the control panel for which is missing. This mansion exhibits some peeling paper flooring and exterior dirt from production use and storage. Dimensions: 64 cm x 115 cm x 76.5 cm (25 1/4" x 45 1/4" x 30 1/4") Contains electronics; see electronics notice in the Buyer's Guide.

Estimate. £1,000 - 1,500



1235
 Young Reggie Dwight's "Rocketman"
 Costume and Piano †Δ
Rocketman (2019)

Young Reggie Dwight's "Rocketman" costume and piano from Paramount Pictures' biographical musical Rocketman. While nearly drowning, Elton John had a vision of his younger self singing and playing "Rocketman" at the bottom of a pool.

The costume comprises a golden jumpsuit made of an embossed foil-like fabric; an orange foam skullcap; a neck-piece with a fan attached; and a pair of golden boots. The fan is powered by AA batteries and the costume is accompanied by four production tags. The piano is a black, wooden child-size grand piano accompanied by a stool. Several of the piano's corners have orange sections attached for SFX purposes. It is not a functioning instrument. Dimensions (piano): 55 cm x 50.5 cm x 49.5 cm (21 3/4" x 20" x 19 1/2") Contains electronics; see electronics notice in the Buyer's Guide.

Estimate. £1,000 - 1,500

1237
 Oversize Clapper Slate †Δ
Rocketman (2019)

An oversized clapper slate from the production of Paramount Pictures' musical biopic Rocketman. This large white acrylic clapper slate features the film's title, director "Dexter Fletcher," and cinematographer "George Richmond" engraved in black, as well as sections for the scene and take numbers. The slate has some scuffs and scratches, most notably around the edges. Dimensions: 55 cm x 88 cm x 0.5 cm (21 3/4" x 34 3/4" x 1/4")

Estimate. £800 - 1,200

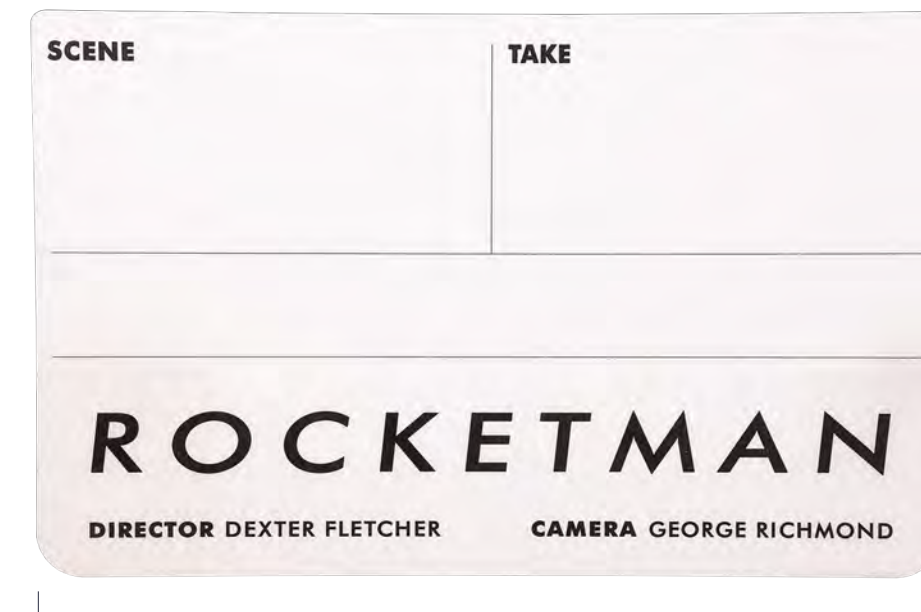

55cm (21.75")

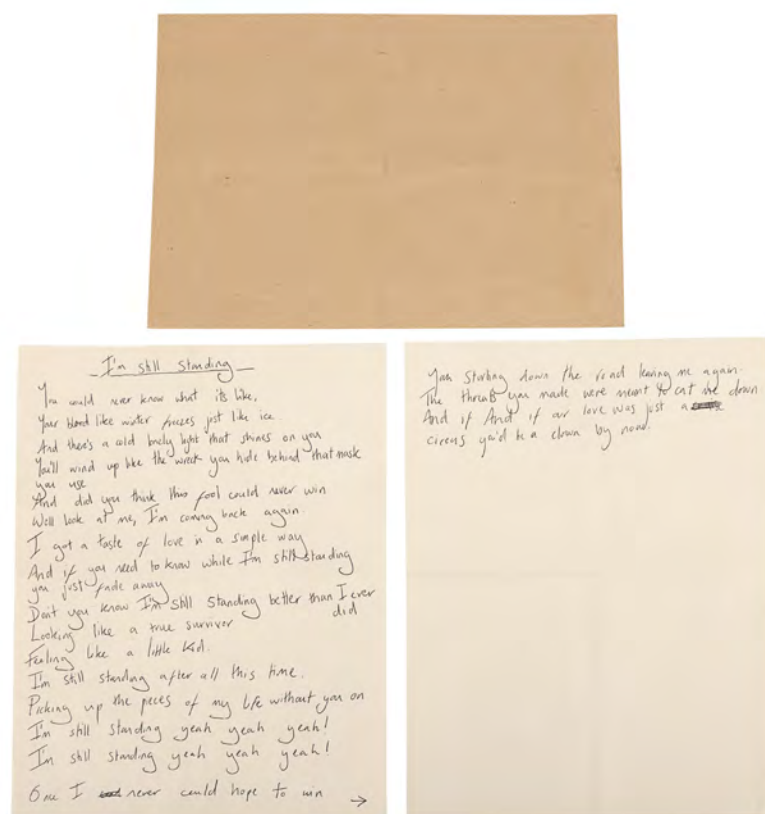

1236
 Elton John's Hero "I'm Still
 Standing" Lyrics and Envelope †Δ
Rocketman (2019)

Elton John's hero "I'm Still Standing" lyrics and envelope from Paramount Pictures' biographical musical Rocketman. Elton was given lyrics at the rehab centre by his friend and writer Bernie Taupin and began composing the music on a piano. This scene transitions into the final sequence of Elton performing a recreation of the "I'm Still Standing" music video.

The lot consists of a brown envelope and two pages featuring printed manuscript writing in black, with a couple of words crossed out. Horizontal fold lines from storage are present on the lyrics and envelope. Dimensions (lyrics): 23 cm x 18 cm (9" x 7"); (envelope): 23 cm x 16 cm (9" x 6 1/4")

Estimate. £800 - 1,200

1238
 Elton John's Unfinished,
 Production-made Devil Costume
 and Components †Δ
Rocketman (2019)

Elton John's unfinished, production-made Devil costume and components from Paramount Pictures' biographical musical Rocketman. Elton wore his flamboyant devil outfit to an addiction rehabilitation session, a scene that is revisited several times throughout the film.

The lot includes two orange-coloured Lycra jumpsuits with matching high-collared jackets; an orange cap; two sets of 3D-printed horns; four prototype fibreglass belt buckles; and a metal buckle decorated with diamantés. Both jumpsuits feature drawn flame-like shapes, which are heavily embellished on the final version of the costume. One belt buckle exhibits fibreglass strands. Dimensions (larger horns): 8 cm x 6.5 cm x 22.5 cm (3 1/4" x 2 1/2" x 8 3/4")

Estimate. £600 - 800



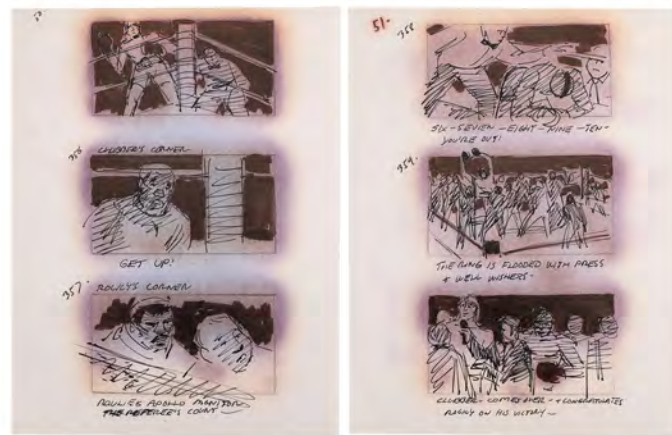

1239
Hand-drawn Rocky Defeats Clubber Storyboard Artwork †Δ
Rocky III (1982)

A set of hand-drawn storyboard artwork from the production of Sylvester Stallone's sports drama film Rocky III. Artist David Negron Sr. illustrated storyboards to plan out the film's meticulously choreographed boxing scenes. The two sheets of wax paper each contain three storyboards depicting the moment Rocky Balboa (Sylvester Stallone) defeated James "Clubber" Lang (Mr. T) in their rematch. Each storyboard is hand-drawn in a combination of pen and marker with detailed annotations, and the pages are numbered "50" and "51". The storyboards exhibit some minor marks, signs of smudging and pinholes. Dimensions (each sheet): 28 cm x 21.5 cm (11" x 8 1/2") Sold without copyright; see notice in the Buyer's Guide.

Estimate. £400 - 600

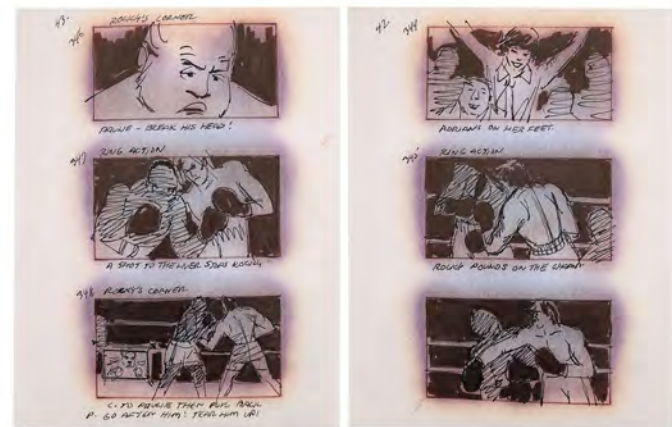

1240
Hand-drawn Rocky Fights Clubber Storyboard Artwork †Δ
Rocky III (1982)

A set of hand-drawn storyboard artwork from the production of Sylvester Stallone's sports drama film Rocky III. Artist David Negron Sr. illustrated storyboards to plan out the film's meticulously choreographed boxing scenes. Labelled "42" and "43", the two sheets of wax paper each contain three storyboards depicting Rocky Balboa's (Sylvester Stallone) rematch against James "Clubber" Lang (Mr. T), hand-drawn in a combination of pen and marker with handwritten annotations. The storyboards exhibit some pinholes, minor marks and signs of smudging. Dimensions (each sheet): 28 cm x 21.5 cm (11" x 8 1/2"). Sold without copyright; see notice in the Buyer's Guide.

Estimate. £400 - 600

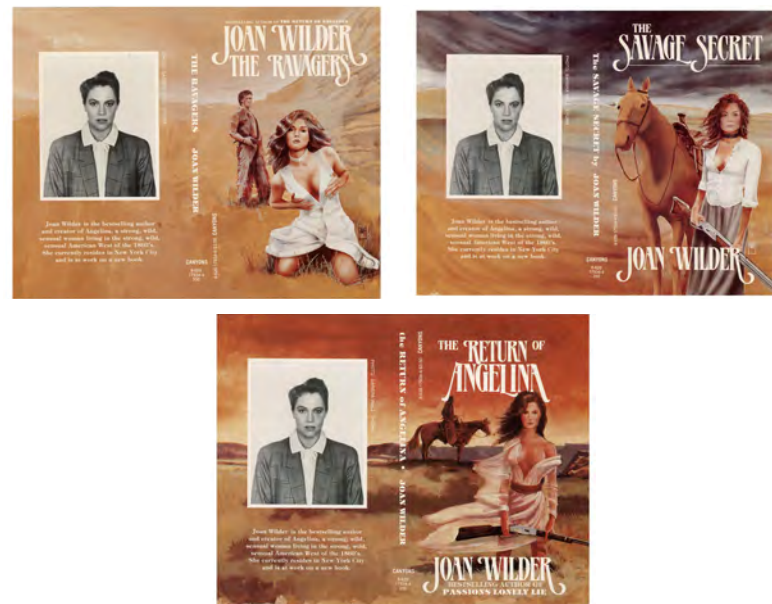

1241
Set of Three Joan Wilder (Kathleen Turner) Romance Novel Covers Ω
Romancing The Stone (1984)

Three Joan Wilder (Kathleen Turner) romance novel covers from Robert Zemeckis' romantic action comedy Romancing the Stone. Wilder and Jack Colton (Michael Douglas) saw many of Wilder's romance novels in drug dealer Juan's (Alfonso Arau) house. This set consists of colour-printed glossy book jackets for Wilder's novels "The Ravagers," "The Return of Angelina," and "The Savage Secret." Each is labelled for the publisher "Canyons" and features a black-and-white photo of Wilder with a short biography on the back cover. They exhibit fold lines from being applied over books, as well as edge wear and pinholes from production use. Dimensions (each): 24.25 cm x 19 cm (9.5" x 7.5")

Estimate. £1,000 - 1,500



1242
Collection of Main Character Hero Swords and SFX Dagger †Δ
Romeo & Juliet (2013)

A collection of main character hero swords and an SFX dagger from Carlo Carlei's adaptation of Shakespeare's Romeo & Juliet. Swords were carried and used throughout the film as the Montagues and Capulets feuded. Juliet (Hailee Steinfeld) used a dagger to stab herself after learning Romeo (Douglas Booth) had taken poison. The collection comprises Romeo's hero sword, fighting sword; Tybalt's (Ed Westwick) hero sword; Mercutio's (Christian Cooke) hero sword; Count Paris' (Tom Wisdom) hero sword; and three additional unfinished and damaged swords. Each sword features swordsmith Del Tin Armi Antiche's stamp at the base of the blade, and the named character swords each come in a leather sheath. Dimensions (each sword): 113 cm x 23 cm x 13 cm (44 1/2" x 9" x 5"); (dagger): 49 cm x 16 cm x 5.5 cm (19 1/4" x 6 1/4" x 2 1/4")

Estimate. £3,000 - 5,000



1243
E.L.F.S. Helmet and Jetpack Ω
Santa Clause 2, The (2002)

An E.L.F.S. helmet and jetpack from Michael Lembeck's holiday comedy The Santa Clause 2. The Effective Liberating Flight Squad (ELFS) wore helmets when they flew their jetpacks around the North Pole in preparation for Christmas. This lot consists of a padded grey resin helmet with a buckling chinstrap labelled "ELFS" on front and a matching fibreglass jetpack with flame patterns painted on the exhaust pipes and a padded red fabric harness labelled "ELFS" affixed on the reverse. They exhibit cracking, glue residue, scratches, and scuffing from production use. Dimensions (jetpack): 37 cm x 24.25 cm x 9 cm (14.5" x 9.5" x 3.5")

Estimate. £1,500 - 2,500



1244
Set of Amanda Young's (Shawnee Smith) Reverse Bear Trap Parts Ω
Saw (2004)

Amanda Young's (Shawnee Smith) reverse bear trap parts from James Wan's horror film Saw. Young woke up to find her head stuck inside a deadly "reverse bear trap" with only 60 seconds to free herself. This set comes directly from the collection of renowned special effects artist Tom "Brooklyn" Bellissimo, who assembled them for a cut scene in which Jigsaw (Tobin Bell) built the bear trap. It consists of four large metal mouthpieces, including one hand-marked "B" and two engraved with Kaiser Aluminum logos; two cables; 11 gears; 17 aluminium panels; 27 nuts and bolts; two popsicle sticks; a Magnum lock; a bronze clasp; and 16 miscellaneous metal components. They exhibit minor bending and some rusting throughout from age. Dimensions: 30.5 cm x 30.5 cm x 15.25 cm (12" x 12" x 6")

Estimate. £3,000 - 5,000



1245
 Detective David Tapp's
 (Danny Glover) Beretta 92FS
Saw (2004)

Detective David Tapp's (Danny Glover) Beretta 92FS from James Wan's horror film Saw. Tapp wielded his firearm while pursuing Jigsaw (Tobin Bell) and defending Alison (Monica Potter) and Diana (Makenzie Vega). This black plastic gun features a "Y and P" logo on the grip, a safety tip painted black, and a working slide, trigger, and hammer. It is blood-stained by production and exhibits yellow paint marks, scratches, and flaking. Dimensions: 21.75 cm x 15.25 cm x 5.25 cm (8.5" x 6" x 2") Ownership may be restricted in some countries; see replica firearm notice in Buyer's Guide. Contains mechanical components; see notice in the Buyer's Guide.

Estimate. £1,200 - 1,800



1246
 Hell House Door Knocker
Scary Movie 2 (2001)

A Hell House door knocker from Keenen Ivory Wayans' horror comedy sequel Scary Movie 2. In a signature visual gag, Cindy Campbell (Anna Faris) used an inappropriate door knocker to enter Hell House. This sculpted, faux bronze knocker originated with a crew member on the film. It is hand-painted grey and bronze-colour to resemble a small metal figure with two heavyweight enlarged testicles dangling from a metal wire beneath the penis and a screw for mounting to a door embedded in the back. The metallic finish exhibits chipping and has turned green from age in places. Dimensions: 34.5 cm x 20.5 cm x 18 cm (13.5" x 8" x 7")

Estimate. £600 - 800



1247
 Oskar Schindler's
 (Liam Neeson) List
Schindler's List (1993)

Oskar Schindler's (Liam Neeson) list from Steven Spielberg's historical drama Schindler's List. With his assistant Itzhak Stern (Ben Kingsley), Schindler assembled a list of "skilled" Jewish workers to be taken to his factory, to save them from Auschwitz. This list consists of 14 printed and photocopied pages detailing the workers' names, birth dates and professions. Some of the names feature printed underlines, marks and crosses. The pages come presented on a clipboard with a silver-painted paper clip. This clip exhibits minor scuffs and scratches, which reveal its blue basecoat. Dimensions (clipboard): 33 cm x 23.5 cm x 5 cm (13" x 9 1/4" x 2")

Estimate. £1,000 - 1,500



1248
 Nancy's (Blake Lively) Bikini, Wetsuit
 Sleeve, and Tank Top
Shallows, The (2016)

Nancy's (Blake Lively) bikini, wetsuit sleeve, and tank top from Jaume Collet-Serra's drama The Shallows. Nancy, a surfer, wore her wetsuit and bikini while stranded on a small island in the ocean surrounded by a fiending great white shark. This lot consists of a string bikini featuring an orange top with decorative padding along the cup interiors and a blue nylon and Spandex-blend bikini bottom with white and orange patterning; a grey, blue, and orange neoprene wetsuit arm intentionally-weathered by production with stains and tears; a tan and white cotton tank top with hand-writing on the tag; a paper production tag with character, performer, and scene information; and another tag with hand-written scene information. The lot exhibits signs of wear, including discolouration.

Estimate. £3,000 - 5,000



1249
 Shaun's (Simon Pegg) Screen-
 matched Bloody Shirt and Tie
Shaun Of The Dead (2004)

Shaun's (Simon Pegg) screen-matched bloody shirt and tie from Edgar Wright's zombie comedy Shaun of the Dead. Shaun wore his shirt and tie throughout the zombie outbreak, which became bloodier and bloodier with each zombie he killed. By the placement of the blood splatter, these items have been matched with the ones seen on-screen, specifically from the scene where Shaun and Ed (Nick Frost) kill the two zombies in their garden, to the moment Shaun runs into zombie Pete (Peter Serafinowicz) in their bathroom. The white cotton shirt is labelled a size 16, buttons up at the front and features red paint splatters across the front, collar and sleeves. The accompanying tie has a diagonal stripe pattern in two tones of red and displays some white marks from production use.

Estimate. £2,000 - 3,000

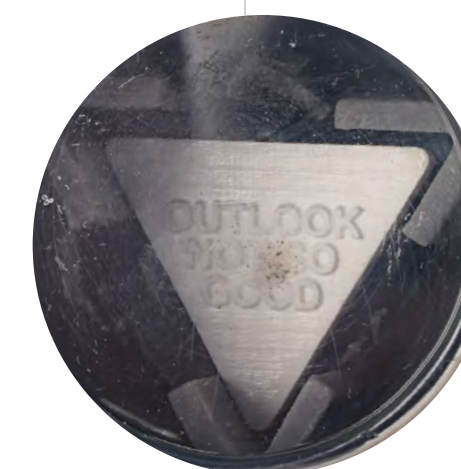

1250
 Pair of Dr. Thaddeus Sivana's (Mark
 Strong) Magic Eight Balls
Shazam! (2019)

A pair of Dr. Thaddeus Sivana's (Mark Strong) Magic Eight Balls from David F. Sandberg's superhero film Shazam! Young Thaddeus (Ethan Pugiotto) was contacted by an ancient wizard (Djimon Hounsou) through his Eight Ball at the beginning of the film, and the adult Thaddeus consulted his Eight Ball throughout the movie. Both plastic balls have been constructed to produce only one answer each - a mystical symbol and "Outlook Not So Good", respectively - and both have been drained of their liquid. They have some scuffing and scratches. Dimensions (each): 10 cm x 10 cm x 10 cm (4" x 4" x 4")

Estimate. £1,000 - 1,500



1251
 Freddy Freeman's (Jack Dylan Grazer) Flattened
 Superman Bullet and Certificate of Authenticity †Δ
Shazam! (2019)

Freddy Freeman's (Jack Dylan Grazer) flattened Superman bullet and certificate of authenticity from David F. Sandberg's superhero film Shazam! Superhero fan Freddy showed off his bullet – flattened after it was shot at Superman – to a nonplussed Billy (Asher Angel). The bullet is made of resin and painted to look like crushed metal. It is accompanied by a prop certificate of authenticity, and both are held in a clear plastic bag. The bag has some small holes on each side near the opening. Dimensions (bullet): 1.5 cm x 1 cm x 0.75 cm (½" x ¼" x ¼"); (certificate): 10.5 cm x 6.5 cm (4" x 2 ½")

Estimate. £600 - 800



1253
 Billy Batson's (Asher Angel) Notebook and Pen †Δ
Shazam! (2019)

Billy Batson's (Asher Angel) notebook and pen from David F. Sandberg's superhero film Shazam! Billy used his notebook to write down names and addresses while searching for his birth mother. The lined notebook has names printed in a handwritten style on the first 12 pages. The rest of the pages are blank. The pen is a blue ballpoint. Dimensions (notebook): 18 cm x 13.5 cm x 1.5 cm (7" x 5 ¼" x ½")

Estimate. £400 - 600



1252
 Three Cast Chair Backs †Δ
Shazam! (2019)

Three cast chair backs from the production of David F. Sandberg's superhero film Shazam! The chair backs are labelled "Sivana" (Mark Strong), "Wizard" (Djimon Hounsou) and "Cast" respectively, and each feature the film's working title "Franklin" on one side. Dimensions (each): 54.5 cm x 17 cm (21 ½" x 6 ¾")

Estimate. £400 - 600



1254
 Sacrificial Dagger Display †M
Sherlock Holmes (2009)

A sacrificial dagger from Guy Ritchie's mystery thriller Sherlock Holmes. A woman under the thrall of Lord Blackwood (Mark Strong) almost killed herself with the dagger before Holmes (Robert Downey Jr.) and Watson (Jude Law) saved her. The dagger has a hard rubber ram's head grip, and a black resin blade. The ram's eyes are faux gems, and the dagger has been intentionally distressed. It comes in a custom-made display featuring a wooden frame and a printed poster for the film. The frame is hinged, allowing access to the dagger, which has some wear from production use and age, including scuffing and scratches. Dimensions (dagger): 37.5 cm x 10.5 cm x 5.5 cm (14 ¾" x 4" x 2 ¼"); (display): 63 cm x 59 cm x 11 cm (24 ¾" x 23 ¼" x 4 ¼")

Estimate. £1,000 - 1,500



1255
 Sherlock Holmes' (Robert
 Downey Jr) Sunglasses †M
**Sherlock Holmes: A Game Of
 Shadows (2011)**

Sherlock Holmes' (Robert Downey Jr) sunglasses from Guy Ritchie's action-adventure sequel Sherlock Holmes: A Game of Shadows. Holmes wore his glasses while disguised as a Chinese opium addict at the start of the film. The glasses have small, round, tinted non-prescription glass lenses and a thin gold-tone frame. They come presented in a green felt-lined case, with a strip of tape adhered to the inside featuring the words "Robert Downey Jnr. A game of Shadows" handwritten in blue pen. There is a small chip on the inside rim of the left lens. Dimensions (glasses laid open): 11.5 cm x 12 cm x 4 cm (4 ½" x 4 ¾" x 1 ½")

Estimate. £1,500 - 2,500



1.97 m (6.45')

1256
 Overlook Hotel Exterior
 Street Lamp †M
Shining, The (1980)

An Overlook Hotel exterior street lamp from Stanley Kubrick's horror film The Shining. Lamps illuminated the gardens and paths of the Overlook Hotel. The lamp is made of steel with glass panels in the lantern. It was shortened to fit and kept by a crew member in his garden for 40 years after filming, and has since been refurbished and repainted, with a new base added, as it was previously planted in the ground. Dimensions: 46 cm x 76.5 cm x 197 cm (18" x 30" x 77 ½") Special shipping required; see special shipping notice in the Buyer's Guide.

Estimate. £3,000 - 5,000



1257
 Overlook Hotel Interior Light Fitting †M
Shining, The (1980)

An Overlook Hotel interior light fitting from Stanley Kubrick's horror film The Shining. Light fittings decorated the walls of the Overlook Hotel lobby. The fitting is made of aluminium and consists of two light holders which slot into a backboard. The fitting has been repainted black since filming. Dimensions: 47 cm x 35 cm x 18 cm (18 ½" x 13 ¾" x 7")

Estimate. £2,000 - 3,000



1258
Overlook Hotel Interior Light Fitting M
Shining, The (1980)

An Overlook Hotel interior light fitting from Stanley Kubrick's horror film *The Shining*. Light fittings decorated the walls of the Overlook Hotel lobby. The fitting is made of aluminium and consists of two light holders which slot into a backboard. The fitting has been repainted black since filming, and a piece of the backboard has broken off around the edge. Dimensions: 47 cm x 35 cm x 18 cm (18 1/2" x 13 3/4" x 7")

Estimate. £2,000 - 3,000



1259
Collection of Rare Behind-the-scenes Photos tΔ
Shining, The (1980)

A collection of rare behind-the-scenes photographs from the production of Stanley Kubrick's classic horror *The Shining*. The lot consists of 59 photographs depicting various crew and key cast members on set during filming. One photograph is a candid headshot of Shelley Duvall, and 11 of the images feature Nicholson posing and joking around with crew members; in many of these he wears his burgundy corduroy jacket. The backs of several photographs exhibit discolouration. Dimensions (each photo): 9 cm x 13 cm (3 1/2" x 5 1/4") Sold without copyright; see copyright notice in the Buyer's Guide.

Estimate. £400 - 600

1260
Hand-Painted Ralph McQuarrie "Alien Spacecraft"
Production Illustration Ω
Showsan (Chevy Commercial)

An "alien spacecraft" production illustration hand-painted by Ralph McQuarrie for a 1987 Chevrolet commercial shot in Showscan. Showscan was a high-speed, large-format filmmaking process pioneered by visual effects master Douglas Trumbull. This advertisement for the Chevrolet Corsica utilised the process to depict a benign abduction by friendly extraterrestrials whose ship McQuarrie designed. This hand-painted illustration of the alien spacecraft, a rare colour example from the production, is rendered in mixed media on Crescent illustration board, signed by McQuarrie, and labelled "Interior Alien Spacecraft Chevrolet Commercial (Showscan)." The board exhibits staining on its borders. Dimensions: 40.75 cm x 33 cm (16" x 13") Sold without copyright; see notice in the Buyer's Guide.

Estimate. £2,000 - 3,000

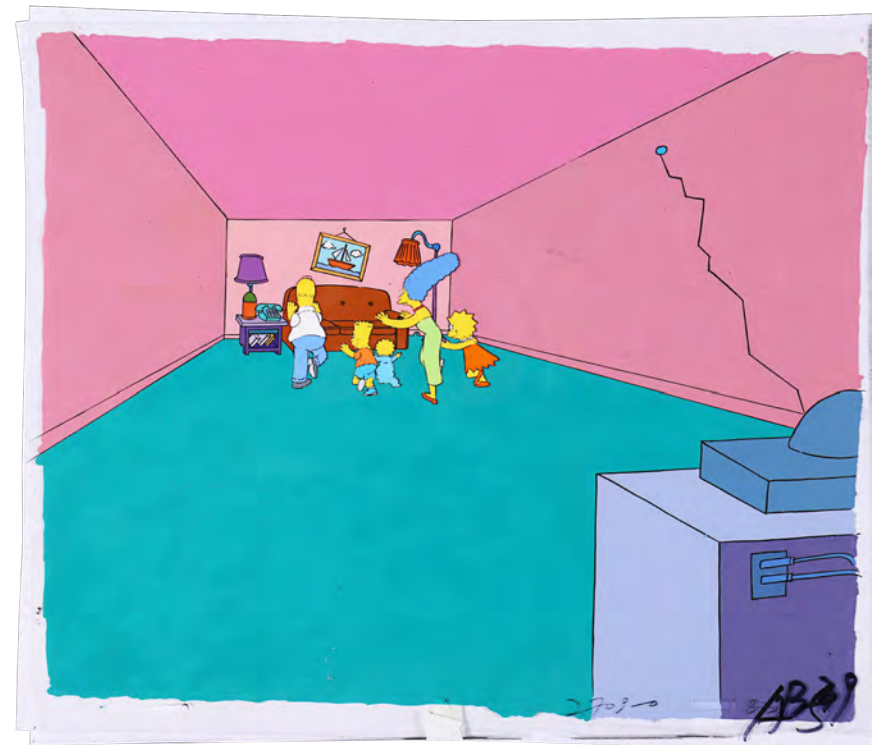

1261
Couch Gag Animation Cel M
Simpsons, The (T.V. Series, 1989 - Present)

A couch gag animation cel from the long-running animated sitcom *The Simpsons*. The cel shows the Simpsons chasing after the couch as it and the wall behind it recede into the distance. This parody of the Terry Gilliam film *Time Bandits* appears in the Season 6 episode "Homer Badman" and was repeated in three later episodes. The cel is plastic and features hand-painted depictions of the eponymous family. Several production codes are handwritten in the bottom right corner. Dimensions: 27 cm x 32 cm (10 1/2" x 12 1/2") Sold without copyright; see copyright notice in the Buyer's Guide.

Estimate. £1,500 - 2,500



1262
Life-size Promotional Theatre
Display of The Simpsons M
Simpsons Movie, The (2007)

A life-size display of *The Simpsons* sitting on their famous couch from the promotion of David Silverman's animated comedy *The Simpsons Movie*. A limited run of life-size statue displays were constructed for movie theatres, giving fans a chance to take their photo with all five Simpson family members. The display comprises life-size fibreglass-and-plastic figures of the Simpsons sitting on a large sofa. The couch is made of wood covered in orange-coloured plastic with black-painted outlining and detailing. There is light damage to the tips of Bart Simpson's hair, signs of scuffing, and cracking on the plastic layer of the sofa, exposing the wood beneath in places. Dimensions: 100 cm x 263.5 cm x 190 cm (39 1/4" x 103 3/4" x 74 3/4") Special shipping required; see special shipping notice in the Buyer's Guide.

Estimate. £1,500 - 2,500

Propstore

Poster Live Auction

Propstore's live auction of rare and collectible posters, artwork and more



London

Spring 2023



James Bond: Dr. No (1962)

UK Quad, 1962

sold for: £16,250 (\$21,000)



1263
Kevin's (Elijah Wood) Severed Head and Glasses +
Sin City (2005)

Kevin's (Elijah Wood) severed head and glasses from Frank Miller and Robert Rodriguez's comic-book crime thriller Sin City. After Goldie (Jaime King) was murdered by psychopathic cannibal Kevin, Marv (Mickey Rourke) tracked him down and wreaked revenge by mutilating and beheading him. Made of silicone, the head displays a close likeness to Wood, with hand-punched hair across the scalp, eyebrows, and eyelashed. The eyeballs are made of resin, featuring painted lines to appear bloodshot. The head is covered in stage-blood spatter, some of which has solidified and stuck to the hair. The head is displayed on a black base and accompanied by a pair of glasses with a metal frame and flexible curved arms. The glasses have been intentionally distressed, featuring stage blood and a broken lens. Dimensions (including base): 25.5 cm x 20 cm x 24.5 cm (10" x 8" x 9 3/4")

Estimate. £3,000 - 5,000



1264
Jackie Boy's (Benicio del Toro) Head +
Sin City (2005)

Jackie Boy's (Benicio del Toro) head from Frank Miller and Robert Rodriguez's comic-book crime thriller Sin City. Jackie Boy's blocked pistol backfired, causing the slide to pierce his forehead, before Miho (Devon Aoki) decapitated him. The head is made of silicone skin and faux hair around a foam core with a metal armature. The head has been intentionally distressed, with a hole in the forehead for the slide, and red paint imitating blood. Dimensions: 26 cm x 18 cm x 28 cm (10 1/4" x 7" x 11")

Estimate. £2,000 - 3,000





1265
 Baghuul (Nicholas King) Long Coat M
Sinister (2012)

Baghuul's (Nicholas King) long coat from Scott Derrickson's *Sinister* and Ciarán Foy's *Sinister 2*. Baghuul is the demonic antagonist of the *Sinister* franchise, using his otherworldly powers to hypnotise children into murdering their families before consuming the child's soul. The coat, seen in both films, is made of dark grey cotton with a blue-grey silk lining. The sleeve cuffs have been unstitched to give a rough appearance, and the coat closes with five pairs of metal button fasteners.

Estimate. £1,000 - 1,500



1266
 Production-used Clapperboard M
Sleepy Hollow (1999)

A clapperboard from the production of Tim Burton's fantasy horror *Sleepy Hollow*. Used by the "B" camera unit during filming, the clapperboard consists of an acrylic slate with a wooden clapper fixed to the top. The slate features the production title "Sleepy Hollow" and the names of director Tim Burton and director of photography Emmanuel Lubezki, all engraved in black. Outlined boxes divide the piece into fields titled scene and take, both of which contain remnants of handwritten details in black marker pen. There are signs of scuffing and paint wear along the clapper arm. Dimensions: 4 cm x 28 cm x 23.5 cm (1 1/2" x 11" x 9 1/4")

Estimate. £2,000 - 3,000



1269
 Hand-drawn Snowy Landscape and House Background M
Snowman, The (1982)

A hand-drawn house background from Dianne Jackson and Jimmy T. Murakami's Academy Award®-nominated Christmas fantasy *The Snowman*. Rendered in colour pencils on paper, the image shows the snowy countryside, with the main character James' family home situated at the centre. The drawing is labelled "Sq1, Sc 8, H 54" and is adhered to a celluloid sheet. The top section has been cut away, and protective tissue paper has been placed behind the celluloid sheet. Dimensions: 33 cm x 26.5 cm (13" x 10 1/2") Sold without copyright; see copyright notice in the Buyer's Guide.

Estimate. £800 - 1,200



1271
 Set of Nine Printed Poster Concept Designs Ω
South Park: Bigger, Longer & Uncut (1999)

Nine printed poster concept designs from the promotion of Trey Parker and Matt Stone's animated comedy *South Park: Bigger, Longer & Uncut*. The tagline ultimately used on the theatrical posters was "Uh-Oh." These poster concept mock-ups are printed in full colour on glossy posterboard featuring the Comedy Central and Paramount logos and dated "99" in the bottom right corner. They feature a variety of early taglines, including "The Hot Ticket This Summer!," "They're About to Cross the Line," and "Invading a Theatre Near You Whether You Like It or Not." The set exhibits some creasing and bending. Dimensions (each): 28 cm x 43.25 cm (11" x 17")

Estimate. £400 - 600



1270
 Cast-autographed Pilot Script M
Sopranos, The (T.V. Series, 1999 - 2007)

A pilot episode script autographed by the cast of Mafia crime drama *The Sopranos*. The script – a post-production photocopy of the screenplay for the show's pilot episode – is bound with two brass fasteners and is autographed by cast members James Gandolfini (Tony Soprano), Lorraine Bracco (Dr. Jennifer Melfi), Edie Falco (Carmela Soprano), Michael Imperioli (Christopher Moltisanti), Robert Iler (A.J. Soprano), Steve Schirripa (Bobby Baccalieri), Vincent Curatola (Johnny Sacramoni) and Aida Turturro (Janice Soprano). The script has a sticker from a previous auction adhered to the cover page. Dimensions: 28 cm x 21.5 cm x 1 cm (11" x 8 1/2" x 1/2")

Estimate. £600 - 800



1272
 Thracian Sword Ω
Spartacus: Blood And Sand (T.V. Series, 2010)

A Thracian sword from the Starz historical action series *Spartacus: Blood and Sand*. Thracian warriors, including Spartacus (Andy Whitfield), wielded swords of this style throughout the season as they joined Spartacus' rebellion.

This metal-bladed sword features a wooden grip with a gold-coloured pommel, matching slatted metal accents, and a studded, crescent-shaped guard. It is intentionally distressed to appear well-used with nicks, dents, and rusting applied to the blade and chips in the grip from production. Dimensions: 91.5 cm x 30.5 cm x 10.25 cm (36" x 12" x 4")

Estimate. £1,500 - 2,500

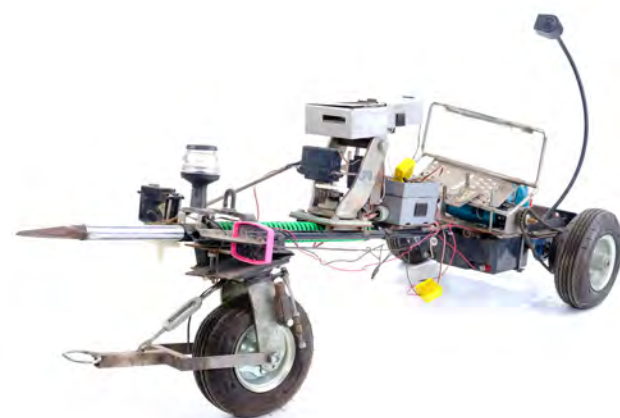

1267
 Chip Hazard's (Tommy Lee Jones) Jackhammer Vehicle US Δ
Small Soldiers (1998)

Chip Hazard's (Tommy Lee Jones) jackhammer vehicle from Joe Dante's sci-fi action film *Small Soldiers*. Hazard chased Christy Fimple (Kirsten Dunst) with his jackhammer vehicle. This custom-made, three-wheeled vehicle is equipped with a motorised disc launcher, a battering ram featuring a jackhammer head fastened to a pogo stick, a cheese grater seat, an LED clip light, power conduits, and a 12-volt drill configured to rotate the tire chain. It exhibits discolouration and damage from production, most notably on the launcher, and is currently nonfunctional. Dimensions: 129.75 cm x 48.5 cm x 58.5 cm (51" x 19" x 23") Contains electronic components; see notice in the Buyer's Guide.

Estimate. £800 - 1,200



1268
 Hand-painted Snowman Hugging James Animation Cel M
Snowman, The (1982)

An original, hand-painted animation cel from Dianne Jackson and Jimmy T. Murakami's Academy Award®-nominated Christmas fantasy *The Snowman*. Rendered in gouache on celluloid, the cel features a poignant moment, when the Snowman hugged the main character James. The drawing is labelled with production sequence numbers "12/8" and "43", and a protective tissue-paper sheet has been placed behind the acetate cel. The colours on the lot remain vibrant, and the cel shows very slight signs of handling at the edges. Dimensions: 27 cm x 33 cm (10 1/2" x 13") Sold without copyright; see copyright notice in the Buyer's Guide.

Estimate. £2,000 - 3,000



1273
Spartacus' (Andy Whitfield) Gladiator Helmet with Greaves Ω
Spartacus: Blood And Sand (T.V. Series, 2010)

Spartacus' (Andy Whitfield) gladiator helmet with greaves from the Starz historical action series Spartacus: Blood and Sand. Thracian slave Spartacus wore his signature helmet and armour throughout Season 1 as he transitioned from gladiator into rebellion leader. This lot consists of a gold-colour resin and metal galea-style helmet labelled "Hoplomuc [sic]" with a red synthetic fur crest, a defensive curved brim, a mesh visor, and leatherette chinstraps, as well as two matching leather and resin lace-up greaves with metal rings on the back painted bronze-colour and hand-labelled "ANDY'S S8" and "Hoplomachus" in the interior. The helmet exhibits extensive distressing by production to look rusted, mouldy, and dinged from age and battle.

Estimate. £1,500 - 2,500



1274
Crixus' (Manu Bennett) Battle Armour Ω
Spartacus (T.V. Series, 2010 - 2013)

Crixus' (Manu Bennett) battle armour from Steven S. DeKnight's historical action series Spartacus. Champion fighter Crixus wore his armour throughout the series as he battled in the gladiatorial arena. This lot consists of a crimson leather plated manica with metal studs and buckles; a matching leather lace-up belt with chainmail tassels and an engraved eagle emblem labelled "Crixus Double"; a silver-colour leather and metal plated gauntlet; a brown cotton loincloth; two animal-patterned gold-colour and silver-colour metal greaves; two blue cotton pads hand-marked "Crixus Hero L" and "Crixus Stunt L"; and two brown leather sandals. The armour exhibits cracked leather and some grime from production wear.

Estimate. £1,200 - 1,800



1277
Ulpius' (Temuera Morrison) Doctore Costume Ω
Spartacus (T.V. Series, 2010 - 2013)

Ulpius' (Temuera Morrison) Doctore costume from the Starz historical action series Spartacus: Gods of the Arena. The lead trainer of gladiators at the Batiatus Ludus, Ulpius wore his costume throughout the series. This costume consists of crimson leather chest armour with beige leather and burlap backing and metal straps; a multicolour striped wool and cotton shawl; a dark grey scarf; multicolour mixed fabric knee-length pants with suede trim; a brown leather wrist bracelet with wool trim hand-marked "Onemaus," "Double," and "Left"; a brown leather lace-up arm guard; and two crimson and brown leather belts with metal details. The costume is intentionally torn throughout and applied with dirt and grime by production to appear well-worn.

Estimate. £600 - 800



1278
Gladiator Fish Shield Ω
Spartacus (T.V. Series, 2010 - 2013)

A gladiator fish shield from the Starz historical series Spartacus. Gladiators wielded shields painted with various sacred animals as they fought to the death throughout the series. This shield is constructed from panelled, wood-backed fibreglass hand-painted brown with four fish designs on the front and metal studs around the edges. The reverse is affixed with both leather and metal arm straps, as well as one foam pad. The shield is distressed by production to appear battle-damaged with scratches, cuts, and small punctures throughout the front. Dimensions: 92.5 cm x 51 cm x 1.5 cm (36.5" x 20" x 0.5")

Estimate. £300 - 500



1275
Thracian Shield Ω
Spartacus (T.V. Series, 2010)

A Thracian shield from the Starz historical series Spartacus: Blood and Sand. Thracian warriors, including Spartacus (Andy Whitfield), wielded shields of this style as gladiators and soldiers at various points throughout the series.

This shield is constructed from metallized resin engraved with Thracian symbols on the front, affixed on the reverse with foam-padded leather arm straps, and applied with a shiny, textured patina to resemble bronze. It exhibits chipping and paint scuffing from production use and age with one of the foam pads missing. Dimensions: 57.25 cm x 57.25 cm x 1.5 cm (22.5" x 22.5" x 0.5")

Estimate. £1,000 - 1,500



1276
Ashur's (Nick Tarabay) Gladiator Shield Ω
Spartacus (T.V. Series, 2010 - 2013)

Ashur's (Nick Tarabay) gladiator shield from the Starz historical action series Spartacus. A former gladiator in the service of Quintus Lentulus Batiatus (John Hannah), Ashur wielded his shield in several battles throughout the series. This wood and leather shield is finished in dark green paint and affixed on the reverse with two foam-padded leather arm straps. It features a moulded resin boss in the centre as well as a decorative metal rim affixed on the edges. The shield exhibits distressing by production to appear battle-worn with scratches, stains, and discolouration throughout. Dimensions: 66.75 cm x 48.25 cm x 1.25 cm (26.25" x 19" x 0.5")

Estimate. £1,000 - 1,500



1279
Spartacus' (Andy Whitfield) Murrillo Gladius and Gladiator Helmet Ω
Spartacus (T.V. Series, 2010)

Spartacus' (Andy Whitfield) murrillo gladius and gladiator helmet from the Starz historical action series Spartacus. Roman-trained gladiator Spartacus wielded his gladius in arena combat throughout Season 1, wearing his helmet while facing experienced fighter Crixus (Manu Bennett). This lot consists of a faux steel sword featuring a curved wooden grip and matching pommel with slatted lines engraved on both; and a resin and metal galea-style helmet featuring a two-layer feathered metal crest, defensive curved details on the front, large circular openings by the eyes, and a padded interior with a leather chinstrap. Also included is a Starz Certificate of Authenticity. Both exhibit intentional battle damage from production, as well as some chipping from use. Dimensions (gladius): 68.75 cm x 9 cm x 9 cm (27" x 3.5" x 3.5")

Estimate. £800 - 1,200



1280
Lucretia's (Lucy Lawless) Dress †Δ
Spartacus: Blood And Sand (T.V. Series, 2010-2013)

Lucretia's (Lucy Lawless) dress from the historical TV series Spartacus: Blood and Sand. Lucretia wore her dress in the Season 1 episodes "Party Favors" and "Revelations", notably in the arena when Spartacus (Andy Whitfield) beheaded Solonius (Craig Walsh-Wrightson). The gown is made of thin red fabric with an orange-and-red trim decorated with gold-coloured floral detailing. Small beads form several small leaves which hang from both shoulders, and a black-and-gold snake-like belt wraps around the waist. Attached within the garment is a low-cut red bodice with gold metal detailing and several metal chains featuring faux crystals hanging down the front. Also included is a purple sash, worn as a loose shoulder covering

Estimate. £2,000 - 3,000



1281
 Spartacus' (Liam McIntyre) Shield
Spartacus: Vengeance (T.V. Series, 2012)/Spartacus: War Of The Damned (T.V. Series, 2013)

Spartacus' (Liam McIntyre) shield from the Starz historical series Spartacus: Vengeance and Spartacus: War of the Damned. Spartacus and his band of escaped slaves wielded matching shields throughout both series as they sought vengeance for their enslavement. This metal-studded resin shield is finished with bronze-colour paint to appear metallic and affixed on the reverse with two foam-padded leather arm straps. The shield is distressed by production to appear well-used with scratches and discolouration throughout, and black ink markings on the reverse have faded with age. Dimensions: 57.25 cm x 45.75 cm x 1 cm (22.5" x 18" x 0.5")

Estimate. £400 - 600

1282
 Spider-Man's (Tobey Maguire) Test Costume Display
Spider-Man (2002)

A Spider-Man (Tobey Maguire) test costume display from the production of Sam Raimi's superhero film Spider-Man. Test costumes are an integral part of the fabrication process and are used in pre-production to assess the construction of different costumes. The Spider-Man costume evolved over the course of the film as Peter Parker (Tobey Maguire) refined the style, until he settled upon the iconic red-and-blue outfit prior to his fight against the Green Goblin (Willem Dafoe). Designed by three-time Academy Award®-winner James Acheson, this spandex costume is presented in a custom-built display with a black wooden frame, a laser-cut mount board and an acrylic pane. Fixed by screws to the base of the mount board is a gold-coloured metal plate with the engraving "SPIDERMAN (2002) - Production made Spiderman torso fabric". At the rear of the frame are metal hanging brackets. Dimensions (displayed): 129 cm x 58 cm x 1.5 cm (51" x 23" x 3/4")

Estimate. £3,000 - 5,000

1283
 Set of Five Daily Bugle Newspaper Covers
Spider-Man (2002)

A set of five Daily Bugle newspaper covers from Sam Raimi's superhero film Spider-Man. Daily Bugle papers were seen being held by various people throughout the film. The headlines read: "N.Y. Fears Costumed Freak!", "Who Is Spider-Man?", "Spider-Man Green Goblin Terrorize Bugle", "Enough!" and "Big Apple Dreads Spider Bite!" Four of the five newspapers feature the same inside pages containing a few articles and television listings, and the back covers all have weather reports. Dimensions (each): 38 cm x 29 cm (15" x 11 1/2")

Estimate. £2,000 - 3,000

1.29 m (4.25')

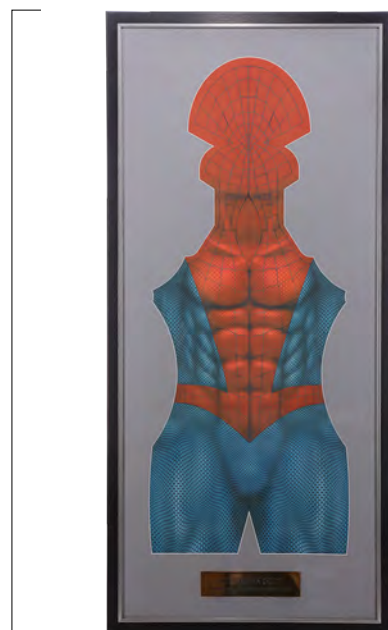

1284
 Set of Five Daily Bugle Newspapers
Spider-Man (2002)

A set of five Daily Bugle newspapers from Sam Raimi's superhero film Spider-Man. Numerous copies of the Daily Bugle were made by production as props and set dressing. Each of these five newspapers features a unique headline and images of Spider-Man (Tobey Maguire) on its front page. These headlines are, respectively, "ENOUGH", "POLICE SEEK SPIDER-MAN", "VIGILANTE EVADES POLICE", "SPIDER-MAN: SUPER HERO OR SUPER ZERO" and "N.Y. FEARS COSTUMED FREAK!" Each newspaper's inside pages feature articles and television listings, with weather reports on the back page. Dimensions (each): 38 cm x 29 cm (15" x 11 1/2")

Estimate. £2,000 - 3,000



1286
 'Times Scare!' Daily Bugle Newspaper Cover
Spider-Man (2002)

A "Times Scare!" Daily Bugle newspaper cover from Sam Raimi's superhero film Spider-Man. A newspaper with this headline was held by J. Jonah Jameson (J.K. Simmons) and it features a picture of Green Goblin's (Willem Dafoe) attack on the Oscorp board in Times Square. The inside pages feature a few articles and television listings, and the back cover has weather reports. Dimensions: 38 cm x 29 cm (15" x 11 1/2")

Estimate. £1,000 - 1,500



1285
 Set of Three Daily Bugle Newspapers
Spider-Man (2002)

A set of three Daily Bugle newspapers from Sam Raimi's superhero film Spider-Man. Numerous copies of the Daily Bugle were made by the production as props and set dressing. One newspaper features the headline "REWARD!", as seen in close-up in Peter Parker's (Tobey Maguire) apartment when he had the idea to earn money taking photographs of himself as Spider-Man. The accompanying two newspaper covers feature the headlines "POLICE SEEK SPIDER-MAN!" and "VIGILANTE EVADES POLICE" respectively, alongside images of Spider-Man. The inside pages of each newspaper feature articles and television listings, with weather reports on the back cover. Dimensions (each): 38 cm x 29 cm (15" x 11 1/2")

Estimate. £1,500 - 2,500



1287
 Two Daily Bugle Newspapers
Spider-Man (2002)

Two Daily Bugle newspapers from Sam Raimi's superhero film Spider-Man. Numerous copies of the Daily Bugle were made by production as props and set dressing. One newspaper features the headline "SPIDER-MAN'S REIGN OF TERROR", with a picture of Spider-Man (Tobey Maguire) climbing down a wall. It can be seen in the film on Daily Bugle editor J. Jonah Jameson's (J.K. Simmons) desk. The other newspaper has the headline "WANTED" above a close up of Spider-Man, as seen plastered across the city after the Green Goblin (Willem Dafoe) attacked Jameson's office. The inside pages of each newspaper feature articles and television listings, with weather reports on the back page. Dimensions (each): 38 cm x 29 cm (15" x 11 1/2")

Estimate. £1,000 - 1,500



1288
Daily Bugle "Who Is Spider-Man?" Newspaper Cover **Spider-Man (2002)**

A Daily Bugle "Who Is Spider-Man?" newspaper cover from Sam Raimi's superhero film Spider-Man. Daily Bugle publisher J. Jonah Jameson (J.K. Simmons) held a newspaper in his hand when he declared Spider-Man a criminal and public menace. The newspaper cover shows a black-and-white blurred image of Spider-Man swinging over the streets of New York with the headline "Who Is Spider-Man?" printed underneath. The interior pages are blank. There are signs of red paint on the front and a small scribble in biro ink on the image. Dimensions: 38 cm x 29 cm x 0.1 cm (15" x 11 1/2" x 1/4")

Estimate. £800 - 1,200



1289
Peter Parker (Tobey Maguire) Press Passes with Daily Bugle Duffel **Spider-Man (2002)**

Peter Parker (Tobey Maguire) press passes and a Daily Bugle duffel from the production of Sam Raimi's superhero film Spider-Man. Although not obviously seen on screen, Parker would have carried his press pass as a photographer for J. Jonah Jameson's (J.K. Simmons) Daily Bugle newspaper. This lot consists of 14 production-made plastic Daily Bugle press passes labelled "Peter Parker", and a grey canvas duffel bag with a shoulder strap and the Daily Bugle logo printed on the side. The passes do not feature photos. Dimensions (duffel, flat): 66 cm x 51 cm x 2.5 cm (26" x 20" x 1")

Estimate. £600 - 800

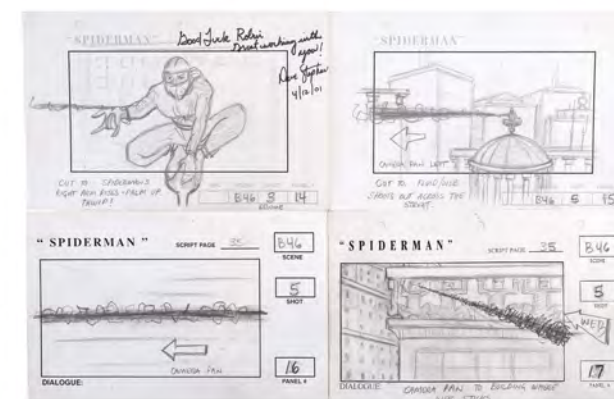

1292
Four Hand-drawn Storyboards **Spider-Man (2002)**

Four hand-drawn storyboards from the production of Sam Raimi's superhero film Spider-Man. Rendered in pencil, the set comprises four consecutive panels of Spider-Man (Tobey Maguire) shooting his web. One panel features a handwritten message to property master Robin L. Miller from storyboard artist David Stephan which reads: "Good luck Robin, Great working with you! Dave Stephan 4/12/01". Dimensions (each): 14 cm x 21.5 cm (5 1/2" x 8 1/2") Sold without copyright; see copyright notice in the Buyer's Guide.

Estimate. £600 - 800

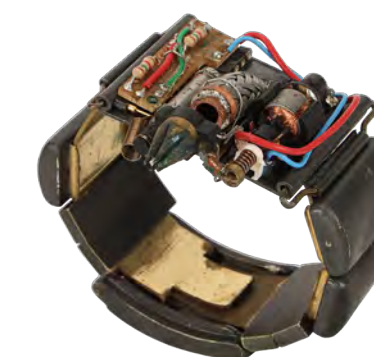

1293
Spider-Man's (Tobey Maguire) Prototype Web-Shooter **Spider-Man (2002)**

A prototype web-shooter from the production of Sam Raimi's superhero film Spider-Man. During the film's development, it was intended that Spider-Man (Tobey Maguire) would use mechanical wrist-mounted web-shooters, as in the comics. However, Raimi ultimately decided that the webs would be generated organically from Spider-Man's wrists, but not before concept art, set photos and some early promotional clips showed Peter Parker (Maguire) testing his DIY mechanical device. The prototype web-shooter features black resin panels mounted to a brass bracelet with a circuit board stapled on top. The shooter includes a pad-activated servomechanism designed to squeeze "webs" from a cartridge through a nozzle on the front of the board. The prototype does not feature any functional mechanical or electronic component. It exhibits rusting, a missing bracelet panel and production wear. Dimensions: 20 cm x 10 cm x 5 cm (8" x 4" x 3/4")

Estimate. £600 - 800



1290
Daily Bugle Newspaper Insert **Spider-Man (2002)**

A Daily Bugle newspaper insert from Sam Raimi's superhero film Spider-Man. Peter Parker (Tobey Maguire) read the Bugle in search of a car to impress Mary Jane (Kirsten Dunst), but found an advert offering \$3,000 to amateur wrestlers. The insert is 11 pages long and features various articles and adverts. Some of the article headlines reference Marvel characters Tony Stark and Wilson Fisk. A few of the pages have become discoloured. Dimensions: 38 cm x 29.5 cm (15" x 11 1/2")

Estimate. £600 - 800



1291
Pair of Tobey Maguire's Chairbacks **Spider-Man (2002)**

Two of Tobey Maguire's chairbacks from the production of Sam Raimi's superhero film Spider-Man. Maguire played Peter Parker, who became the heroic Spider-Man after a radioactive spider bit him at Oscorp. These canvas chairbacks, one royal blue and one navy, each feature the production's spider logo printed in red on one side and the actor's name printed in red on the other side. The pair exhibits fold lines and white staining from production use. Dimensions (each): 28 cm x 19 cm x 1.5 cm (11" x 7 1/2" x 1/2")

Estimate. £600 - 800



1294
Prototype Green Goblin (Willem Dafoe) Pumpkin Bomb **Spider-Man (2002)**

A prototype Green Goblin (Willem Dafoe) pumpkin bomb from the production of Sam Raimi's superhero film Spider-Man. After transforming himself into the supervillain known as the Green Goblin, industrialist Norman Osborne wielded his signature pumpkin bombs as explosives and bladed weapons, among other offensive uses. This orange spherical bomb is made of resin and features a button-like accent with eight raised details on one side. Its entire surface is decorated with a series of textured rectangular elements. It exhibits some discoloration and staining throughout, with some moulding excess on the rear section. Dimensions: 9 cm x 9 cm x 9 cm (3.5" x 3.5" x 3.5")

Estimate. £400 - 600



1295
"Spider-Man No More" Daily Bugle Newspaper with Inserts **Spider-Man 2 (2004)**

A Daily Bugle newspaper headlined "Spider-Man No More" with inserts from Sam Raimi's superhero sequel Spider-Man 2. J. Jonah Jameson (J.K. Simmons) reported on Spider-Man's (Tobey Maguire) trashed costume in the Daily Bugle after Peter Parker quit as the superhero. This production-made, colour-printed newspaper cover headlined "Spider-Man No More" features a picture of the costume and the credit line "Photo by Eddie Brock." The cover is applied over separate unrelated inserts printed on newspaper stock to fill the interior. It exhibits edge tearing and creasing from being folded widthwise. Dimensions: 38.25 cm x 29.25 cm x 2.5 cm (15" x 11.5" x 1")

Estimate. £1,000 - 1,500

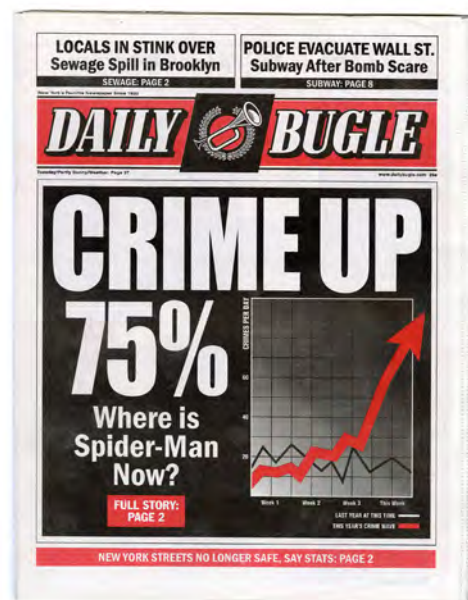

1296
 "Crime Up 75%" Daily Bugle Newspaper with Heavyweight Inserts Ω
Spider-Man 2 (2004)

A Daily Bugle newspaper headlined "Crime Up 75%" with heavyweight inserts from Sam Raimi's superhero sequel Spider-Man 2. Run by editor J. Jonah Jameson (J.K. Simmons), the Daily Bugle newspaper attempted to blame Spider-Man (Tobey Maguire) for New York's rising crime rate. This lot consists of a production-made, colour-printed newspaper cover headlined "Crime Up 75%: Where is Spider-Man Now?" with a graph of rising crime rates. The cover is applied over a separate newspaper printed on heavyweight paper stock. The lot exhibits tearing at top and edge wear throughout from production. Dimensions: 38.25 cm x 29.25 cm x 2.5 cm (15" x 11.5" x 1")

Estimate. £1,000 - 1,500



1297
 Set of 13 Venom (Topher Grace) Costume Fitting Photographs Ω
Spider-Man 3 (2007)

13 Venom (Topher Grace) costume fitting photographs from the production of Sam Raimi's superhero sequel Spider-Man 3. Disgraced Daily Bugle photographer Eddie Brock became the host for an extraterrestrial symbiote, turning him into the black suit-clad Venom. These photographs were taken during test fittings for Venom's costume by specialty costuming firm Frontline Design. Each is printed on glossy colour photo stock along with the Frontline logo and mounted to black construction paper. The set exhibits minor creasing throughout from production. Dimensions (each): 63.5 cm x 94 cm (25" x 37") Sold without copyright; see copyright notice in the Buyer's Guide.

Estimate. £600 - 800



1298
 Production-used Clapperboard \mathcal{M}
Splendor In The Grass (1963)

A clapperboard from the production of Elia Kazan's Oscar®-winning period drama Splendor in the Grass. The clapperboard features a wooden clapper, a metal hinge and a chalkboard slate, with its contents applied in white stencil. The slate features the abbreviated title "Splendour"; director Kazan's name; cinematographer Boris Kaufman's surname and initial; and production company Newtown Productions, abbreviated as "Newtown". Outlined boxes further divide the clapperboard into sections comprising scene, take, sound, date and exterior. A strip of white adhesive tape has been applied to the slate, upon which the roll number is handwritten in marker pen. The clapperboard shows paint erosion, scuffs and rust. Dimensions: 35.5 cm x 28.5 cm x 4.5 cm (14" x 11 1/4" x 1 3/4")

Estimate. £2,000 - 3,000



1299
 Engineering Radiation Suit \mathcal{M}
Star Trek: The Motion Picture (1979)

An engineering radiation suit from Robert Wise's sci-fi film Star Trek: The Motion Picture, which was repurposed for Nicholas Meyer's sequel Star Trek II: The Wrath of Khan. Starfleet engineers wore their radiation suits while aboard the Enterprise. This lot consists of a cream-coloured jumpsuit, one red collar (worn by cadets), one black foam collar (worn by officers), a pair of cream-coloured boots with chunky, black rubber heels, and a pair of fleece-lined gloves. The jumpsuit features a Starfleet patch on the right shoulder, a yellow rank band around the left arm, elastic stirrups and a detachable back. The front of the jumpsuit displays a central mesh crest encircled by piping, a metal disc, and two heavy-duty clips. The boots have the initials "L.L." handwritten on the inside in black pen, and the gloves display the name "Robot M". The lot exhibits wear from production use, including staining, deterioration of the foam on the black collar and cracking to the leather gloves.

Estimate. £3,000 - 5,000



1300
 Pair of Storyboard Binders Ω
Star Trek: The Motion Picture (1979)

Two storyboard binders for Robert Wise's sci-fi film Star Trek: The Motion Picture. Production planned out shooting and SFX sequences in storyboard form during pre-production, then distributed copies of those storyboards to key departments. These white vinyl three-ring binders - one labelled "1" and one labelled "2" - contain production-made Paramount Pictures copies of 504 individual storyboards spanning the entirety of the film with printed annotations in the margins. The storyboards are alphabetised with file dividers and organised by film sequence. The binders exhibit yellow discolouration and markings from age and storage. Dimensions (each): 28.75 cm x 29.25 cm x 7.75 cm (11.25" x 11.5" x 3")

Estimate. £1,500 - 2,500



1301
 Framed Hand-Drawn Andy Probert "Enterprise Meeting V'ger" Storyboard Ω
Star Trek: The Motion Picture (1979)

A framed "Enterprise meeting V'ger" storyboard hand-drawn by production illustrator Andy Probert for Robert Wise's sci-fi film Star Trek: The Motion Picture. The massive, sentient ship V'ger attempted to interact with the U.S.S. Enterprise. This storyboard depicting the Enterprise encountering V'ger is rendered in mixed media on black paper signed and dated "6.28.79" by Probert. It comes mounted behind glass in a black wood and metal frame affixed with a hanging wire. Black matting inside the frame exhibits some staining from handling. Dimensions: 30.5 cm x 12.75 cm x 0.75 cm (12" x 5" x 0.25") Sold without copyright; see notice in the Buyer's Guide.

Estimate. £800 - 1,200



1302
Yellow Satin SFX Crew Jacket [Ω](#)
Star Trek: The Motion Picture (1979)

A yellow satin SFX crew jacket from Robert Wise's sci-fi film *Star Trek: The Motion Picture*. Jackets of this style were gifted to crew members. This yellow satin zip-up bomber jacket (size XS) is embroidered "Special Effects Crew" in navy blue on the left breast with the film's title and Enterprise logo embroidered in matching blue and yellow on the reverse. While satin jackets from this era are frequently heavily faded, this jacket retains its vibrant colouration. It exhibits minor snagging and abrasions on the back, as well as loose threads and faint blue staining on the sleeves from wear.

Estimate. £500 - 700



1303
"Heroes Of The Final Frontier" Cast Autographed Photo [Ω](#)
Star Trek V: The Final Frontier (1989)

A framed photo autographed by the cast of William Shatner's sci-fi sequel *Star Trek V: The Final Frontier*. The photo has been autographed in silver pen by Shatner (Captain Kirk), Leonard Nimoy (Mr. Spock), George Takei (Sulu), DeForest Kelley (Dr. McCoy), James Doohan (Scottie), Nichelle Nichols (Uhura) and Walter Koenig (Chekov). It is mounted under acrylic above a plaque featuring the character names, images of the USS Enterprise and the Enterprise-A, and the words "Limited Edition 1560/2500". There are some scratches on the acrylic. Dimensions: 41 cm x 41 cm x 4 cm (16" x 16" x 1 1/2")

Estimate. £1,000 - 1,500

1304
EVA Phaser Rifle [Ω](#)
Star Trek: First Contact (1996)

An EVA phaser rifle from Jonathan Frakes' sci-fi sequel *Star Trek: First Contact*. Picard (Patrick Stewart), Worf (Michael Dorn), and Hawk (Neal McDonough) armed themselves with rifles to stop the Borg from using the deflector dish to call reinforcements. This rubber rifle is moulded around an internal metal armature, affixed with a black nylon shoulder strap on the left side, and painted silver-colour and black with black decals applied on top. It exhibits wear from use and age, including scuffs and scratches, and the paint has worn away in some places. Dimensions: 90 cm x 6 cm x 14 cm (35.5" x 2.5" x 5.5")

Estimate. £3,000 - 5,000



1305
2378 Type-2 "Dolphin" Phaser [Ω](#)
Star Trek: Nemesis (2002)

A 2378 Type-2 "dolphin" phaser from Stuart Baird's sci-fi film *Star Trek: Nemesis*. The 2378 phaser variant differed from its predecessors in its more streamlined shape, its switch from rectangular to round buttons, and silver-colour emitter. An alternate-colour version of the 2378 variant was previously used in a deleted scene from *Star Trek: Voyager's* series finale. This static black and silver-colour resin phaser features a grooved handle and three static buttons with reflective decals. The phaser exhibits scuffs and scratches in the painted finish, and peeling in the decals exposing the original button colours underneath. Dimensions: 20.5 cm x 5.25 cm x 5.25 cm (8" x 2" x 2")

Estimate. £2,000 - 3,000



1306
Set of 18 Hand-Illustrated Doug Brode Concept Artworks [Ω](#)
Star Trek (2009)

A set of 18 pieces of concept artwork hand-illustrated by prop illustrator Doug Brode for J.J. Abrams' sci-fi film *Star Trek*. Concept artists on the film strived to find a balance between the iconic classic designs and fresh updated designs for the props and costumes of the reimagined *Star Trek*. These artworks are rendered in mixed media on 18 sheets of paper, signed by Brode, depicting Federations headsets, Vulcan telepathy enhancers, Sulu's sword, weapons including Klingon weapons and accessories, Spock's mask for a deleted scene, and a jackhammer-like device with arm and leg assists. The drawings exhibit crumpling and edge wear throughout. Dimensions (each): 28 cm x 43.25 cm (11" x 17") Sold without copyright; see notice in the Buyer's Guide.

Estimate. £500 - 700

1307
Flying Parasite [+](#)
Star Trek: The Original Series (T.V. Series, 1966 - 1969)

A flying parasite from "Operation: Annihilate!", episode 29 of the first season of *Star Trek*. Flying parasites caused the inhabitants of the Federation colony Deneva to go insane. One also attached itself to Mr. Spock (Leonard Nimoy) and infected him. The parasites were often found at rest on walls and ceilings and seemed immune to the crew's phaser blasts. When attacking, however, they flew at their intended hosts and latched on, subsequently becoming known as "flying pizza" by collectors and fans. The creature is made of silicone, and has become discoloured with age, turning a darker brown/green. Some of the silicone around the edge has frayed and torn and there is a split underneath, revealing some of the red silicone inside. It is accompanied by a letter of authenticity detailing its history. Dimensions: 23 cm x 16.5 cm x 1.5 cm (9" x 6 1/2" x 1/2")

Estimate. £2,500 - 3,500

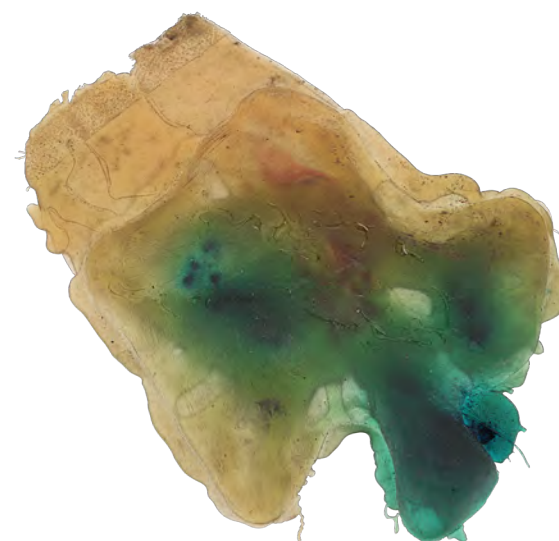



1308
 Cast Autographed Photo Ω
Star Trek: The Original Series (T.V. Series, 1966 - 1969)

A framed photo autographed by the cast of Star Trek: The Original Series. The photo is autographed in black pen by William Shatner (Captain Kirk), Leonard Nimoy (Mr. Spock), George Takei (Sulu), DeForest Kelley (Dr. McCoy), James Doohan (Scottie), Nichelle Nichols (Uhura) and Walter Koenig (Chekov). It is mounted under acrylic above a plaque featuring the character's names, an image of the USS Enterprise, and the words "Limited Edition 200/2500". There is some light scratching on the acrylic. Dimensions: 51.5 cm x 51.5 cm x 4 cm (20 1/4" x 20 1/4" x 1 1/2")

Estimate. £1,000 - 1,500



1309
 Data's (Brent Spiner) Hand and Sleeve \mathbb{M}
Star Trek: The Next Generation (T.V. Series, 1987-1994)

Data's (Brent Spiner) hand and sleeve from Gene Roddenberry's sci-fi television series Star Trek: The Next Generation. The piece was used in the Season 7 episode "Phantasms", for a nightmare sequence in which Data was attacked and dismantled by workmen. The hand is cast in latex and painted faux gold to match Data's skin tone. It is attached to a latex forearm covered by a length of Data's uniform sleeve, which has a brown satin lining. A thin metal rod is located within the forearm, which was held by the actor during filming. There are slight chips and marks to the paint on the hand from production use and age. Dimensions: 53.5 cm x 17 cm x 7 cm (21" x 6 3/4" x 2 3/4")

Estimate. £2,000 - 3,000



1310
 Full Starship Transfers Sheet \mathbb{M}
Star Trek: The Next Generation (T.V. Series, 1987-1994)

A full sheet of starship transfers from sci-fi series Star Trek: The Next Generation. The sheet contains various Starfleet insignia and fonts, including the U.S.S. Enterprise name and its registry numbers NCC-1701-A and NCC-1701-D. The sheet also includes the Klingon emblem and several complete alphabets in various sizes. The sheet has some minor creasing. Dimensions: 43 cm x 58.5 cm (17" x 23")

Estimate. £1,000 - 1,500



1311
 Starfleet Operations Tunic \mathbb{M}
Star Trek: The Next Generation (T.V. Series, 1987 - 1994)

A Starfleet operations tunic from the sci-fi series Star Trek: The Next Generation. Introduced in the third season, this style of uniform was worn by Starfleet personnel working in the operations division throughout the remainder of the series. This yellow and black wool tunic features a raised collar with yellow piping along its edge, a rear zipper, a fastening strip on the chest for attaching a combadge, and a sewn-in Paramount tag marked "Michael" and "G21." The ink of the "G21" marking exhibits fading.

Estimate. £1,000 - 1,500



1312
 Set of Six Crew Plaques Ω
Star Trek: The Next Generation (T.V. Series, 1987 - 1994)/Star Trek: Voyager (T.V. Series, 1995 - 2001)

Six crew plaques from the productions of Gene Roddenberry's sci-fi television series Star Trek: The Next Generation and Star Trek: Voyager. Commemorative plaques were gifted to crew members at the end of each season. This set consists of wood and acrylic plaques labelled for Seasons 5 through 7 of TNG and Seasons 1, 2, and 4 of Voyager. Each features a different logo printed on the acrylic. They exhibit minor fading and slight gouging from handling. Dimensions (largest): 42 cm x 24.25 cm x 4 cm (16.5" x 9.5" x 1.5"); (smallest): 15.25 cm x 18 cm x 4 cm (6" x 7" x 1.5")

Estimate. £800 - 1,200

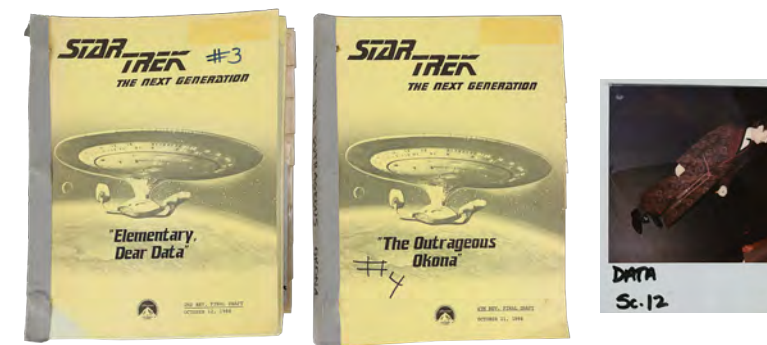

1314
 Pair of Costume Continuity Season 2 Scripts -
 "Elementary, Dear Data" and "The Outrageous Okona" -
 with Cast Polaroids $\dagger\Delta$
Star Trek: The Next Generation (T.V. Series, 1987-1994)

A pair of costume continuity scripts from the production of the sci-fi television series Star Trek: The Next Generation. The scripts are for the Season 2 episodes "Elementary, Dear Data" and "The Outrageous Okona". Both feature a copy of the script and pages detailing the costumes needed in the episode. They have handwritten notes and some pages are accompanied by polaroids, including for main cast actors Patrick Stewart, Brent Spiner, Diana Muldaur, LeVar Burton, and Michael Dorn, and for guest actors, including Whoopi Goldberg, Teri Hatcher and Joe Piscopo. Each script has the title handwritten down the spine and both have small tears and staining from age and production use. Dimensions (each script) 28 cm x 23 cm x 2 cm (11" x 9" x 3/4") Sold without copyright; see notice in the Buyer's Guide.

Estimate. £800 - 1,200

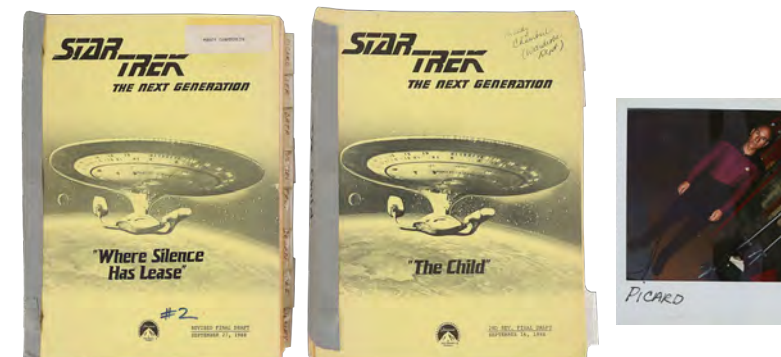

1313
 Pair of Costume Continuity Season 2 Scripts - "The Child"
 and "Where Silence Has Lease" - with Cast Polaroids $\dagger\Delta$
Star Trek: The Next Generation (T.V. Series, 1987-1994)

A pair of costume continuity scripts from the production of the sci-fi television series Star Trek: The Next Generation. The scripts are for the Season 2 episodes "The Child" and "Where Silence Has Lease". Both feature a copy of the script and pages detailing the costumes needed in the episode. They have handwritten notes and some pages are accompanied by polaroids, including for main cast actors Patrick Stewart, Jonathan Frakes, Brent Spiner, Marina Sirtis, Diana Muldaur, and Michael Dorn, and for guest actors, including Whoopi Goldberg and Colm Meaney. Each script has the title handwritten down the spine and both feature the name of costumer Amanda Chamberlin on the covers. Dimensions (each script) 28 cm x 23 cm x 2 cm (11" x 9" x 3/4") Sold without copyright; see notice in the Buyer's Guide.

Estimate. £800 - 1,200



1315
 Cast Autographed Photo Ω
Star Trek: The Next Generation (T.V. Series, 1987-1994)

A photo autographed by the cast of sci-fi series Star Trek: The Next Generation. This printed photo has been autographed in marker pens of different colours by Patrick Stewart (Captain Picard), Jonathan Frakes (Commander Riker), Gates McFadden (Dr. Crusher), Brent Spiner (Data), Michael Dorn (Worf), Marina Sirtis (Counsellor Troi), LeVar Burton (Geordi La Forge) and Whoopi Goldberg (Guinan). The photo is a printed copy of a promotional still. Dimensions: 20 cm x 28 cm (8" x 11")

Estimate. £800 - 1,200



1316
Set of Five Cast Polaroids M
Star Trek: The Next Generation
(T.V. Series, 1987-1994)

Five Polaroids featuring cast members from sci-fi series Star Trek: The Next Generation. These photographs were used by the costume department to ensure continuity between scenes. They feature Marina Sirtis (Deanna Troi), LeVar Burton (Geordi La Forge), Wil Wheaton (Wesley Crusher) and two pictures of John de Lancie (Q). Four of the Polaroids feature handwritten notes in black ink, and all have their episodes written in pencil on the back. Each photograph has tape remnants. Dimensions (each): 10.5 cm x 9 cm (4 1/2" x 3 1/2") Sold without copyright; see copyright notice in the Buyer's Guide.

Estimate. £600 - 800

1317
Freighter Model Miniature
with Cobra Command Logos Ω
Unknown Star Trek Production

A freighter model miniature with Cobra Command logos from an unknown Star Trek production. Based on the Ken Larson "Ranger 3" prototype used as a Katarian ship in "Buck's Duel to the Death" of Buck Rogers in the 25th Century, this model is similar to Jaheel's (Jack Kehler) ship from the Deep Space Nine episode "Babel", but with different detailing and no signs of redressing, so it is not believed to be the filming model, despite its illustration in Star Trek Fact Files. Neelix's (Ethan Phillips) ship in Voyager, the Baxial, was based on a similar design. This resin miniature is painted grey and beige with red and grey bottom storage compartments; wiring visible beneath; two rear lights; the labels "D-1655," "JP40," and "ASTM;" and red and black Cobra Command logos (never meant to be distinguishable on camera) on the front and sides. It exhibits flaking paint, exposed resin, and a loose top compartment. Dimensions: 39.5 cm x 15.25 cm x 10.25 cm (15.5" x 6" x 4") Contains electronic components; see notice in the Buyer's Guide.

Estimate. £3,500 - 5,500

1318
Small LCARS Keypad Ω
Star Trek: The Next Generation
(T.V. Series, 1987 - 1994)

A small LCARS access panel from the sci-fi series Star Trek: The Next Generation. The crew of the Enterprise used keypads to access the ship's main computer system, the LCARS (Library Computer Access and Retrieval System) throughout the series. Designed to appear illuminated when backlit, this black acrylic panel features a sheet of graphics with simulated purple, red, and orange touch-screen buttons in the series' iconic LCARS (Library Computer Access and Retrieval System) style taped to the back. The acrylic exhibits some scratching, and the tape is peeling in some places from production. Dimensions: 16 cm x 11 cm x 0.75 cm (6.25" x 4.25" x 0.25")

Estimate. £1,000 - 1,500



1319
Bajoran Phaser Rifle M
Star Trek: Deep Space Nine (T.V. Series, 1993 - 1999)

A Bajoran phaser rifle from sci-fi TV series Star Trek: Deep Space Nine. Bajoran phaser rifles were used in multiple episodes by members of the Bajoran Resistance. They were originally designed by illustrator Jim Martin and were first seen on-screen in the third-season episode "Shakaar". Made of solid cast resin, the phaser rifle features an ergonomic black grip; a guard which surrounds the hand; open shoulder stocks; and straps. It is painted to look bronze and has hand-painted red-and-gold detailing. The paint has chipped away around some of the edges and corners. Dimensions: 65 cm x 23 cm x 6 cm (25 1/2" x 9" x 2 1/2")

Estimate. £2,000 - 3,000

1320
Framed Light-Up Klingon
Wardroom Panel Ω
Star Trek: Deep Space Nine (T.V. Series, 1993 - 1999)

A framed light-up Klingon wardroom panel from the sci-fi series Star Trek: Deep Space Nine. Klingon panels lined Deep Space Nine's wardroom throughout the series, including in the Season 7 episode "When It Rains.." when General Martok (J.G. Hertzler) was inducted into the Order of Kahless. This large colour panel is designed to illuminate from behind when plugged into an AC power outlet. It comes mounted behind glass in a black metal frame. The panel exhibits some discolouration from production use and age along its edges. Dimensions: 139.75 cm x 75 cm x 2.5 cm (55" x 29.5" x 1") Contains electronic components; see notice in the Buyer's Guide.

Estimate. £600 - 800



1321
Tom Paris' (Robert Duncan McNeill)
Captain Proton Ray Gun Ω
Star Trek: Voyager (T.V. Series, 1995 - 2001)

Tom Paris' (Robert Duncan McNeill) Captain Proton ray gun from the sci-fi drama series Star Trek: Voyager. Paris wielded his 1950s inspired ray gun throughout Season 5 as he assumed the identity of serial play hero Captain Proton in the Holodeck. This silver-colour resin ray gun features a cylindrical shaped scalloped grey barrel and a body with silver-colour and blue detailing throughout. Its grip is affixed on both sides with textured black accents. It is missing the sight on the end of the barrel and exhibits scuffing to the paint throughout. Dimensions: 29.25 cm x 16.75 cm x 5.25 cm (11.5" x 6.5" x 2")

Estimate. £1,200 - 1,800





1322
Suliban Resistance Energy Pistol Ω
Star Trek: Enterprise (T.V. Series, 2001 - 2005)

A Suliban resistance energy pistol from the sci-fi series Star Trek: Enterprise. In the pilot episode "Broken Bow," members of the Suliban resistance movement, including Sarin (Melinda Clarke), used unique energy pistols distinctly lacking the more organic look of other Suliban weaponry. This black and silver-colour resin and plastic energy pistol features green and brass-colour striping, and a red button on the trigger designed to illuminate a small light on the emitter tip powered by batteries in the grip. It exhibits scuffing in the painted finish of both the silver-colour body and the black grip. The lighting element is not currently functional as the wiring in the battery compartment needs some repair. Dimensions: 20.5 cm x 15.25 cm x 7.75 cm (8" x 6" x 3") Contains electronic components; see notice in the Buyer's Guide.

Estimate. £2,500 - 3,500

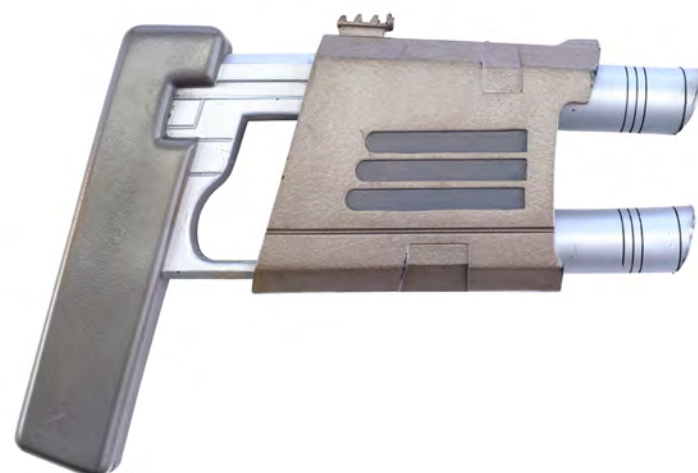

1323
Nausicaan Disruptor Pistol Ω
Star Trek: Enterprise (T.V. Series, 2001 - 2005)

A Nausicaan disruptor pistol from the sci-fi series Star Trek: Enterprise. In the Season 1 episode "Fortunate Son," Nausicaan warriors brandished their disruptors when they besieged the ECS Fortunate, a seemingly defenceless cargo ship. This dense rubber disruptor pistol features a pair of silver-colour under and over cylindrical barrels affixed to a trapezoidal housing with a grey hand grip and a built-in trigger guard. Also included is a brown plastic and suede holster. It exhibits paint chipping around the barrel and exposed rubber from production use. Dimensions: 26.75 cm x 16.75 cm x 3 cm (10.5" x 6.5" x 1.25")

Estimate. £2,500 - 3,500



1324
NERVA Thruster Model Ω
Star Trek: Enterprise (T.V. Series, 2001 - 2005)

A NERVA thruster model from the sci-fi series Star Trek: Enterprise. High-ranking Starfleet officers, such as Admiral Maxwell Forrest (Vaughn Armstrong), decorated their offices with antique space program memorabilia. This model, created to commemorate NASA and the Atomic Energy Commission's 1960s NERVA (Nuclear Engine for Rocket Vehicle Applications) program, is made of metal with elements painted yellow, blue, and red and decaled logos for NASA, the A.E.C., and "NERVA." It is mounted on a wooden base and exhibits scuffed paint and decals, scratches in the wood, and a loosening mount. Dimensions: 24.25 cm x 11.5 cm x 29.25 cm (9.5" x 4.5" x 11.5")

Estimate. £800 - 1,200



1325
Klingon Mask \mathcal{M}
Star Trek: Discovery (T.V. Series, 2017 - 2022)

A Klingon mask from sci-fi TV series Star Trek: Discovery. Klingons were antagonists, and occasional allies, to the crew of the USS Discovery and Starfleet. The species was redesigned for the series, which gave them pointier heads and no hair, as well as altering their clothing, technology and architecture. This silicone mask features a prominent ridged forehead, nose and skull. It is painted a purple hue with some grey detailing. "Kid Klingon Girl" is handwritten inside the neckline at the back, and the mask is displayed on a black foam bust.

Estimate. £2,000 - 3,000



1327
Picnic Set and Whisky Gift-box Crew Gifts \mathcal{M}
Lucasfilm

A picnic set and whisky gift-box crew gift from Lucasfilm, the production company behind the Star Wars franchise. Presented in a green-and-brown nylon picnic bag, the set includes a detachable bottle carrier; a thermal-lined bag; an outdoor blanket; a chopping board; four plates, cups, napkins and sets of utensils. Also included in the lot is a wooden "Lucasfilm Ltd" gift box containing a Star Wars-themed whiskey decanter; two glasses featuring decals of The Mandalorian and The Clone Wars; six whiskey stones; and two "XI" coasters. Both sets come in cardboard storage boxes. Dimensions (picnic set): 52 cm x 41 cm x 29 cm (20 1/2" x 16" x 10 1/4"); (whiskey box): 37.5 cm x 32.5 cm x 13 cm (14 3/4" x 12 3/4" x 5 1/4")

Estimate. £800 - 1,200



1326
Stunt Starfleet Type II Hand Phaser $\dagger\Delta$
Star Trek: Discovery (T.V. Series, 2017 - 2022)

A stunt Starfleet Type II hand phaser from Seasons 1-3 of Star Trek: Discovery and Seasons 1-2 of Star Trek: Short Treks. Starfleet officers used a unique variant of the iconic Type II hand phaser to defend themselves from enemies throughout both series. The phaser comprises a black foam body with cast details including non-functional buttons and dials, a stationary trigger, a three-emitter front, and an embedded Type I phaser with a Starfleet delta on it. Remnants of gold and silver-coloured paint remain around elements such as the rear stripes and trigger. There is some bubbling to the foam, most notably at the top of the weapon. Dimensions: 23 cm x 4.5 cm x 17 cm (9" x 1 3/4" x 6 3/4")

Estimate. £2,000 - 3,000



1328
Set of ILM Crew Gifts \mathcal{M}
Industrial Light & Magic (Ilm)

A set of crew gifts from the visual effects company Industrial Light & Magic. Items were gifted to members of the crew for their work on various productions. The set comprises: 27 pins dedicated to ILM productions, each featuring the dates of production and "ILM VFX"; a Solo: A Star Wars Story leather crew bag; an ILM T-shirt (size XL); a mesh cap; a beanie featuring Grogu from The Mandalorian; a handkerchief; and a protective lower-face mask. Dimensions (Solo bag): 43 cm x 35 cm x 12 cm (17" x 13 3/4" x 4 3/4")

Estimate. £600 - 800



1329
LucasFilm Record Player and Crew Gifts M
Lucasfilm

A set of crew gifts from the Star Wars franchise production company LucasFilm. The set comprises of: a LucasFilm Ltd themed record player with a UK and US power adapter; three black t-shirts (size XL) with various LucasFilm-themed designs; a 50 Years celebration pin; a deck of Star Wars-themed playing cards; a necklace with three charms; a notebook and pen. The record player comes in a box with titles of current and future productions on the sides. Dimensions: (record player in box) 40.5 cm 35 cm x 15 cm (16" x 13¾" x 6") Contains electronics; see electronics notice in the Buyer's Guide.

Estimate. £400 - 600



1330
Pair of Staff-Signed
"Yoda on Planet" Christmas Cards Ω
Lucasfilm

Two "Yoda on Planet" Christmas cards signed by staff members of Lucasfilm. These 2003 holiday cards feature printed illustrations by Industrial Light & Magic (ILM) artist Kathryn Otoshi of Yoda sitting on a planet on their fronts with the message "Envisioning Unlimited Possibilities for the New Year" on their interiors. One card is hand-signed and inscribed by three Lucasfilm employees to ILM visual effects producer Thomas G. Smith, and one features what are believed to be secretarial signatures made on behalf of George, Katie, Amanda, and Jett Lucas. Both exhibit ink staining. Dimensions (each): 20.5 cm x 12.75 cm (8" x 5")

Estimate. £400 - 600



1333
Wookiee Hand, Wookiee Teeth Sculpt, and Tion
Medon (Bruce Spence) Ear Covers Ω
Star Wars Prequel Trilogy (1999 - 2005)

A wookiee hand, a wookiee teeth sculpt, and five Tion Medon (Bruce Spence) ear covers from George Lucas' Star Wars prequel trilogy. Tion Medon was the Pau'an administrator of the Pau City port who greeted Obi-Wan Kenobi (Ewan McGregor) in Revenge of the Sith. The five ear covers are made of fibreglass and painted metallic teal. The wookiee hand is made of rubber, and the teeth sculpt is made of resin around a metal frame. The hand is dry and cracked, and remains in a fragile condition. The teeth sculpt is missing a tooth. Dimensions (each ear cover): 7 cm x 7 cm x 1.5 cm (2¾" x 2¾" x ¾")

Estimate. £800 - 1,200



1334
Yoda Mouth and Teeth Casting Ω
Star Wars: The Phantom Menace (1999)

A Yoda mouth casting from the production of George Lucas' Star Wars prequel trilogy. As Yoda (Frank Oz) was originally a puppet in The Phantom Menace, the production team needed to construct functional moving parts, some of which remained unfinished. The item is a foam-latex casting of Yoda's open mouth showing all 13 teeth and a tongue. It is unpainted and still has its mould lines. There are also slight depressions at the back, where a hand would manipulate the mouth. Dimensions: 11.5 cm x 9.5 cm x 4 cm (4½" x 3¾" x 1½")

Estimate. £400 - 600



1331
Set of Lucasfilm Employee Ephemera ΩΔ
Lucasfilm

A set of Lucasfilm employee ephemera. This set consists of a white plastic bag commemorating a Special Olympics benefit screening of The Empire Strikes Back on May 17th, 1980; a cream-colour glossy cardstock ESB program; a colour paper invitation for the 1996 July 4th Lucasfilm Picnic; a colour invitation on holographic-accented cardstock for the "Viva Las Lucas" event on December 12th, 1998; two colour cardstock invitations and a flyer for an Attack of the Clones employee screening on May 11th, 2002; and a colour cardstock holiday card and envelope. The set exhibits various signs of handling. Dimensions: 28 cm x 35.75 cm x 1.25 cm (11" x 14" x 1")

Estimate. £600 - 800



1332
Neimoidian Mask Ω
Star Wars Prequel Trilogy (1999 - 2005)

A Neimoidian mask from George Lucas' Star Wars prequel trilogy. The Neimoidians ran the Trade Federation, and by cooperating with the Sith and joining the Confederacy of Independent Systems, they helped spark the Clone Wars. The mask is made of foam latex painted olive green with mottled tones. It sits atop a black plastic stand with a metal frame, and tape has been adhered to the interior by production. The mask has recently undergone sympathetic restoration and exhibits minor flaking and fissures from age and production wear. Dimensions: 56 cm x 33 cm x 25.5 cm (22" x 13" x 10")

Estimate. £2,000 - 3,000

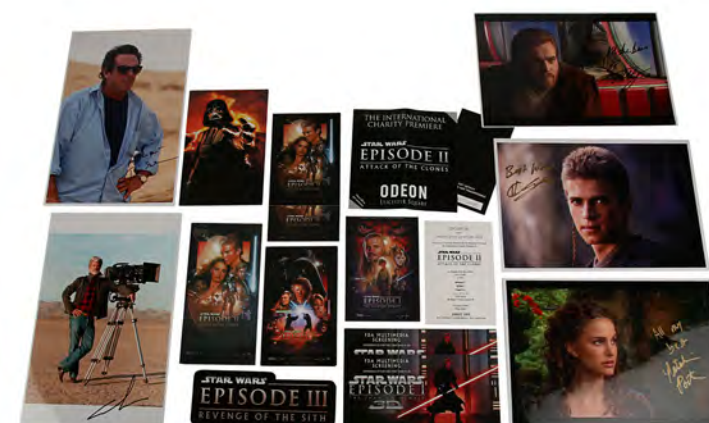

1335
George Lucas and Main Cast Autographed Stills and
Screening Tickets †Δ
Star Wars Prequel Trilogy (1999 - 2005)

A collection of autographed promotional stills and screening tickets from the production and promotion of the Star Wars prequel trilogy. The five stills feature writer-director George Lucas, Ewan McGregor (Obi-Wan Kenobi), Hayden Christensen (Anakin Skywalker), Natalie Portman (Padmé Amidala) and producer Rick McCallum, each of whom has autographed their photo in either black or gold-coloured marker. The lot also includes 10 tickets for various screenings of The Phantom Menace, Attack of the Clones and Revenge of the Sith, all featuring the locations, dates and times for each event. Completing the lot is a windscreen identification label. Dimensions (each still): 30 cm x 20.5 cm (11¾" x 8"); (largest ticket): 19 cm x 12.5 cm (7½" x 5")

Estimate. £400 - 600



1336
Production-Made Unfinished Mace Windu (Samuel L.
Jackson) Lightsaber Ω
Star Wars Prequel Trilogy (1999 - 2005)

A Mace Windu (Samuel L. Jackson) lightsaber from the production of George Lucas' Star Wars prequel trilogy. Jedi Master Windu wielded his signature lightsaber throughout the series, including when he duelled with Jango Fett (Temuera Morrison) on Kamino. This lightsaber is made of cast resin with a white glossy finish and sculpted details throughout. It exhibits some wear from handling and age, including cracking and chipping. Dimensions: 26.75 cm x 5.25 cm x 5.25 cm (10.5" x 2" x 2")

Estimate. £2,000 - 3,000



1337
Production Made Unfinished Lightsabers for Qui-Gon Jinn, Obi-Wan Kenobi and Ki-Adi Mundi †
Star Wars: The Phantom Menace (1999)

Three unfinished lightsabers from the production of George Lucas' Star Wars: The Phantom Menace. The resin lightsabers are unfinished versions of Qui-Gon Jinn (Liam Neeson), Obi-Wan Kenobi (Ewan McGregor) and Ki-Adi-Mundi's (Silas Carson). The lightsabers have some imperfections from the casting process, and a grey-coloured filler was used to smooth some holes. Dimensions (longest): 28.5cm x 4 cm x 4 cm (11 ¼" x 1 ½" x 1 ½")

Estimate. £2,000 - 3,000



1338
Vertical Podracing Rock Formation Model Miniature Ω
Star Wars: The Phantom Menace (1999)

A vertical podracing rock formation model miniature from George Lucas' Star Wars: The Phantom Menace. Anakin Skywalker (Jake Lloyd) won his freedom in a podrace through the deserts of Tatooine. Industrial Light & Magic (ILM) created physical models of rock elements for the sequence, with images of the models' textures then projected onto digital forms to create the final look of the desert elements. This vertical oriented foam, metal, and wood model is hand-painted tan and grey to resemble stone, and mounted to a wooden base. It exhibits peeling paint with exposed metal underneath. The base remains unfinished. Dimensions: 45.75 cm x 45.75 cm x 51 cm (18" x 18" x 20")

Estimate. £1,500 - 2,500



1341
Geonosis Outcropping Model Miniature Ω
Star Wars: Attack Of The Clones (2002)

A Geonosis outcropping model miniature from George Lucas' Star Wars: Attack of the Clones. The Clone Wars were initiated when the Confederacy of Independent Systems and the Galactic Republic fought in the Battle of Geonosis. Industrial Light & Magic (ILM) rendered the planet's towering rock formations by creating and photographing physical model miniatures, then projecting them as large-scale environmental elements. This model miniature for a Geonosian outcropping surrounding the arena is constructed of particle board and foil, painted in shades of tan and blue to appear rocky, and distressed to appear textured. It exhibits visible signs of use from production, including scuffed paint throughout. Dimensions: 63.5 cm x 42 cm x 59.75 cm (25" x 16.5" x 23.5")

Estimate. £1,000 - 1,500



1342
Mace Windu (Samuel L. Jackson) Signature Edition Replica Lightsaber †
Star Wars: Attack Of The Clones (2002)

A Master Replicas Mace Windu (Samuel L. Jackson) signature edition lightsaber from the promotion of George Lucas' Star Wars: Attack of the Clones. Master Replicas based this limited-edition 2003 release on digital scans of the original hero lightsaber from the Lucasfilm Archives. The hilt is made of chrome-plated metal with anodized gold-coloured detailing and black rubber sections forming the grip. It comes presented within a black display case lined with blue velvet. Also included is an additional plexiglass display case with a Samuel L. Jackson autographed Master Replicas and Lucasfilm plaque identifying it as number 587 of 750 made. Some minor marks are present on the hilt, and the lot comes with a certificate of authenticity. Dimensions (plexiglass case): 36.5 cm x 12.5 cm x 15.5 cm (14 ¼" x 5" x 6")

Estimate. £800 - 1,200

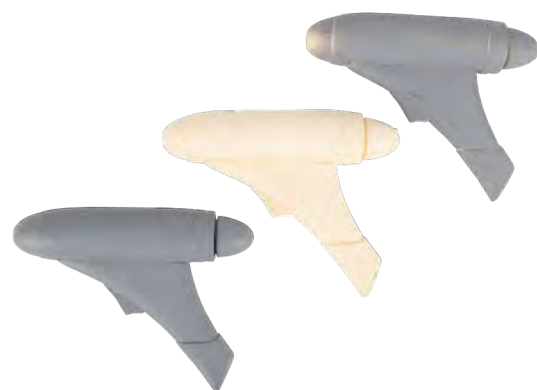

1339
Prototype Queen Amidala (Natalie Portman) Blasters †
Star Wars: The Phantom Menace (1999)

Three prototype Queen Amidala (Natalie Portman) blasters from the production of George Lucas' Star Wars: The Phantom Menace. The blasters are made of resin, and two are painted grey. The blasters have some markings and imperfections from the casting process. Dimensions (each): 16 cm x 3.5 cm x 12.5 cm (6 ¼" x 1 ½" x 5")

Estimate. £800 - 1,200



1340
Rare Yoda Department Crew Gift M
Star Wars: The Phantom Menace (1999)

A rare Yoda Department crew gift from the production of George Lucas' Star Wars: The Phantom Menace. This particular item and others were given to the individuals who brought Yoda (Frank Oz) to life. Made of unpainted resin, the gift depicts a cheerful Yoda atop a dome with an inscription reading "Yoda Team '97". On the back is the name "Pollard", likely attributing the original sculpt to key sculptor Gary Pollard. The gift comes in a star-themed gift box containing a card dedicated to the gift's recipient. Dimensions (gift): 9 cm x 6 cm x 6 cm (3 ½" x 2 ½" x 2 ½")

Estimate. £600 - 800



1343
Anakin Skywalker (Hayden Christensen) Burnt Hand Make-up Ω
Star Wars: Revenge Of The Sith (2005)

An Anakin Skywalker (Hayden Christensen) burnt hand make-up appliance from George Lucas' Star Wars: Revenge of the Sith. Burnt-looking prosthetics were created for the epic final confrontation between Anakin and Obi-Wan Kenobi (Ewan McGregor) on the fiery world of Mustafar; specifically when Obi-Wan severs Anakin's left arm and both his legs, before leaving his old friend to be consumed by flames. Though not obviously seen on screen, the hand make-up (created for the left hand) is made of foam latex, with the appearance of exposed bone on the backs of the fingers. It is painted in a caucasian flesh tone, with black to represent charring. The hand shows significant degradation to the foam latex and paint. Dimensions: 22 cm x 13 cm x 1 cm (8 ½" x 5" x ¼")

Estimate. £400 - 600



1344
Darth Vader Replica Helmet †
Star Wars: Revenge Of The Sith (2005)

A Darth Vader replica helmet from George Lucas' Star Wars: Revenge of the Sith. This Master Replicas® helmet was created from moulds for an original helmet located at the Lucasfilm archives. It is made of fibreglass with machined metal detailing, and comes with a display stand, a plaque and certificate of authenticity. The plaque is labelled "Limited Edition: 1029" and only 1,500 were made. No original packaging is present. Dimensions: 38 cm x 34 cm x 30 cm (14 ½" x 13" x 11 ½")

Estimate. £1,000 - 1,500



1345
R2-D2 Droid Components M
Star Wars: A New Hope (1977)

A set of R2-D2 droid components from the production of George Lucas' Star Wars: A New Hope. R2-D2 (Kenny Baker) was Luke Skywalker's (Mark Hamill) plucky astromech droid, and many components were made and used for the multiple R2 units used throughout production. The set comprises six pieces of machined aluminium: a blue-tinted tube seen on each foot joint; an upper leg joint socket; a pair of upper leg bolts; a "locomotion power cell" component; a "heat exhaust" cap; and a bayonet socket light fitting. Each component shows signs of wear from use on production, such as glue residue, paint degradation and car body filler. Dimensions (foot joint tube): 18.5 cm x 3.5 cm x 3.5 cm (7 1/4" x 1 1/2" x 1 1/2")

Estimate. £3,000 - 5,000



1346
Ceremonial Rebel Trooper Jacket M
Star Wars: A New Hope (1977)

A ceremonial Rebel trooper jacket from George Lucas' Star Wars: A New Hope. Rebel troopers wore ceremonial jackets as part of their uniforms during the final scene, where Han Solo (Harrison Ford) and Luke Skywalker (Mark Hamill) were presented with medals for destroying the Death Star during the Battle of Yavin. Based on vintage United States Marines "dress greens", the green woollen jacket features a stand-up collar with a pair of metal fasteners. A Bermans & Nathans label is sewn to the lining and displays "38c, 5'10" handwritten in blue ink. The jacket is in good overall condition, with signs of light wear and some loose threads.

Estimate. £2,000 - 3,000

1347
Krayt Dragon Rib Ω
Star Wars: A New Hope (1977)

A krayt dragon rib from George Lucas' Star Wars: A New Hope. C-3PO (Anthony Daniels) walked past the skeletal remains of a krayt dragon in the Tatooine desert. Bone fragments were recovered from the sand dunes of Tunisia where the sequence was filmed. This rib shard is constructed from fibreglass and painted in an off-white bone colour. Metal hooks are affixed to the back with plaster for mounting to the large-scale dragon body. The rib exhibits significant fracturing and cracking, discolouration, and flaking to its finish from many years in the Sahara. Dimensions: 52.25 cm x 12.75 cm x 12.75 cm (20.5" x 5" x 5")

Estimate. £3,000 - 5,000

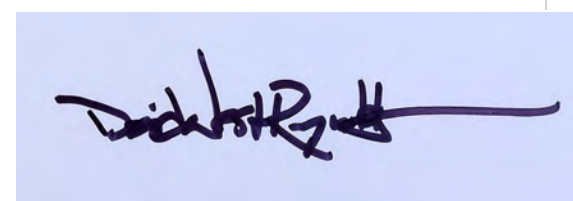

1348
David West Reynolds-Signed Small Ribbed Cantina Door Frame Section Ω
Star Wars: A New Hope (1977)

A cantina door frame section from George Lucas' Star Wars: A New Hope signed in black marker by author David West Reynolds. Luke Skywalker (Mark Hamill) and Obi-Wan Kenobi (Alec Guinness) first encountered smuggler Han Solo (Harrison Ford) in the iconic Mos Eisley cantina sequence. While difficult to discern in the finished film, this variant of the design is visible in behind-the-scenes footage. This ribbed, rectangular vacuformed plastic sheet is painted white and grey, and mounted to grey foam board for preservation and display. In addition to the signature, the back is marked "4B." It exhibits paint fading, staining, and visibly cracked plastic. Dimensions: 45.75 cm x 11.5 cm x 5.25 cm (18" x 4.5" x 2")

Estimate. £800 - 1,200



1350
"Star Nars" X-Wing Crew T-Shirt Ω
Star Wars: A New Hope (1977)

A "Star Nars" X-wing crew shirt from the production of George Lucas' Star Wars: A New Hope. Given to Industrial Light & Magic (ILM) crew members early in production, this style of shirt came to be known as the "Star Nars" shirt due to the letter "W" being cut off. This beige cotton crew-cut T-shirt (size XL) features the words "STAR WARS" in bold red and black block letters behind an early illustration of an X-wing. The shirt exhibits some paint splatters and holes in the front, back, and sleeves from previous wear.

Estimate. £1,500 - 2,500



1349
Promotional X-Wing Pilot Helmet M
Star Wars: Original Trilogy (1977 - 1983)

An X-Wing pilot helmet from the promotion of George Lucas' Star Wars: Original Trilogy. Helmets were made in promotion of the franchise some time in the 1980s. This particular helmet was made from the original production moulds and used to promote merchandise sold at Selfridges. The helmet is made from panels of vac-formed plastic pinned together with rivets. It is painted white with red accents, features a transparent orange visor and the Rebel Alliance decals typically seen on Luke Skywalker's (Mark Hamill) helmet. Dimensions: 28 cm x 24 cm x 24 cm (11" x 9 1/2" x 9 1/2")

Estimate. £2,000 - 3,000



1351
Joe Johnston Original Production-used X-Wing and Y-Wing Designs M
Star Wars: A New Hope (1977)

A pair of framed, original Joe Johnston blueprint designs from the production of George Lucas' Star Wars: A New Hope. Johnston was a design artist on the production and worked specifically in the miniature and optical effects unit. The lot comprises two printed designs: one featuring the rear view of an X-Wing starfighter, and the other the top and undersides of a Y-Wing. The pair are printed on paper measuring 16" by 11" and come displayed in a wooden frame with a pane of acrylic. The frame exhibits scratches and light paint wear. Dimensions (each frame): 55 cm x 51 x 1.5 cm (21 3/4" x 20" x 1/2")

Estimate. £800 - 1,200

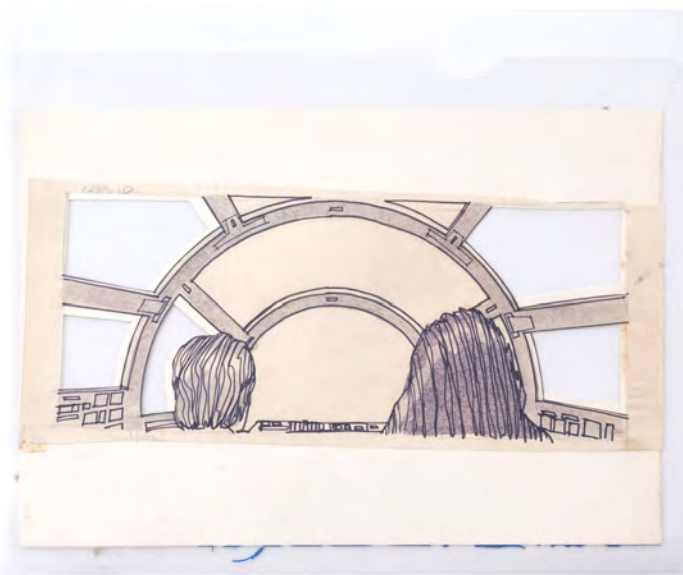

1352
Hand-Drawn Storyboard [Ω](#)
Star Wars Saga

A hand-drawn storyboard from the production of George Lucas' Star Wars saga. This storyboard depicted Han Solo and Chewbacca in the cockpit of the Millennium Falcon. This storyboard consists of two layers of paper with its illustration (on the top layer) rendered in ink. The side windows of the cockpit have been cut out of both layers. The storyboard exhibits minimal ink smudging, staining on the sides between the layers from adhesives, and the two layers have come apart. Dimensions: 19.25 cm x 28 cm (7.5" x 11") Sold without copyright; see notice in the Buyer's Guide.

Estimate. £2,000 - 3,000



1353
Star Wars Wrap Party Crew Photos [Ω](#)
Star Wars: Various Productions

A collection of crew photos from a Star Wars wrap party from various productions. These behind-the-scenes photographs feature cast and crew members with their families both onset at the Death Star and offset at a wrap party. This lot consists of seven film photographs (12.75 cm x 9 cm) mounted on black paperboard. George and Marcia Lucas, Harrison Ford, Mark Hamill, Robert Watts, and other notable figures appear in the set. These pictures feature a yellow tone due to the type and age of the dye used in film prints when they were chemically processed, making these pictures unique to this time. This collection exhibits lifted adhesive and wear on the edges of the photos. Dimensions (each): 40.75 cm x 51 cm (16" x 20") Sold without copyright. See notice in the Buyer's Guide.

Estimate. £1,000 - 1,500



1354
37 Star Wars Behind-the-Scenes Stills and LucasArts "MIRAGE" Flipbook [Ω](#)
Lucasfilm

37 behind-the-scenes stills from George Lucas' Star Wars: A New Hope and a flipbook for LucasArts' "MIRAGE." Following production, sets from A New Hope were struck and dumped on the Elstree Studios backlot. These black-and-white stills show various recognizable discarded setpieces, including a full-size X-wing, at Elstree. Also included is a flipbook showcasing "MIRAGE," a large-scale, multiplayer, multimedia entertainment system developed between LucasArts and technology company Hughes Training. As "MIRAGE" was never completed, surviving materials like this plastic-bound flipbook featuring printed illustrations and dated "1991 LucasArts" are rare. The binding exhibits tears from handling. Dimensions: 45.75 cm x 28 cm x 2.5 cm (18" x 11" x 1")

Estimate. £800 - 1,200

CHARLES LIPPINCOTT COLLECTION

Lots in this section of the auction come from the collection of Charles "Charley" Lippincott. Lippincott is considered among the foremost marketing and merchandising experts in the history of fantasy and science-fiction. After an early start in traditional Hollywood publicity, his career exploded when college friend George Lucas hired him as Lucasfilm's VP of Advertising, Publicity, Promotion & Merchandising, a role he used to create arguably the most successful - and bombastic - marketing campaign ever for Lucas' 1977 blockbuster Star Wars. Lippincott subsequently masterminded the publicity strategies for such era-defining properties as Ridley Scott's Alien and Mike Hodges' Flash Gordon. The popularity of these projects further propelled him into the top ranks of film executives, leading him to produce Danny Cannon's cult classic Judge Dredd. While Charley Lippincott passed away in 2020, his personal collection of rare unseen production and marketing materials reflects a legacy of influence on some of cinema's most memorable titles. All auction registrants will also be entered into a random giveaway drawing to win a T-shirt or brochure produced by Lippincott for the 2016 convention MidAmeriCon 2 ("MAC II") which re-united Gary Kurtz, Alan Dean Foster, Marc Pevers, and Gary Kurtz. The giveaway is made possible by Lippincott's estate.



1356
Charles Lippincott Collection: 20th Century Fox Press Clippings Photo Book [Ω](#)
Star Wars: A New Hope (1977)

A 20th Century Fox press clippings photobook from George Lucas' Star Wars: A New Hope. This book was created by Stanley Bielecki, who represented Fox movies to the press and created the book to show Fox executives that he was helping get press for the film. The plastic comb-bound book comes from the collection of the film's advertising and publicity supervisor Charles "Charley" Lippincott. It features 14 pages of black-and-white articles with high gloss pages and matte backs. This lot exhibits some residue between the pages causing some sticking, notable black ink marks on the matte sides, and edge wear on the pages. Dimensions: 40.75 cm x 51 cm x 1.5 cm (16" x 20" x 0.5")

Estimate. £1,000 - 1,500



1355
Charles Lippincott Collection: Cast and Crew Glory Book [Ω](#)
Star Wars: A New Hope (1977)

A cast and crew glory book from George Lucas' Star Wars: A New Hope. This plastic spiral-bound photo book comes from the collection of the film's advertising and publicity supervisor Charles "Charley" Lippincott, who hand-carried a batch of photo-covered books to the US from the film's UK production office, and personally gave them to people to explain the film. Photo-covered versions such as this were assembled directly by Lippincott and Stanley Bielecki, in whose lab the photos were printed. This example is rarer than the triangle-sticker cover version gifted to most crew due to its black glossy cardstock cover featuring Mark Hamill, Harrison Ford, Carrie Fisher, and Peter Mayhew in costume above an early Star Wars logo. It contains a handwritten 20th Century Fox label dated "1976" and 25 black-and-white photos on the interior. The book exhibits light edge wear, creasing, and minor marking. Dimensions: 26.75 cm x 20.5 cm x 1.5 cm (10.5" x 8" x 0.5")

Estimate. £3,000 - 5,000

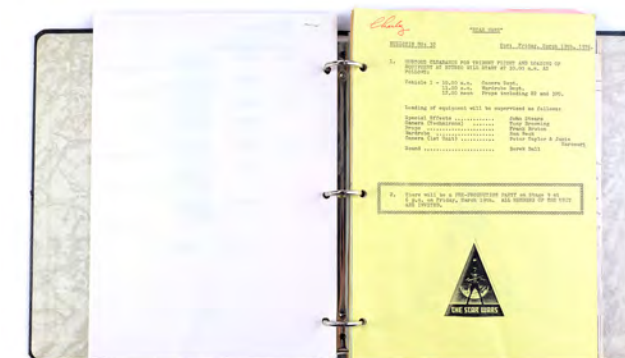

1357
Charles Lippincott Collection: Charles "Charley" Lippincott's Pre-Production Schedule Binder [Ω](#)
Star Wars: A New Hope (1977)

Charles "Charley" Lippincott's schedule binder from pre-production of George Lucas' Star Wars: A New Hope. Lippincott was the film's advertising and publicity supervisor, and an instrumental figure in the global success of the franchise. This black vinyl National three-ring binder comes from Lippincott's collection. It consists of 55 pages of memos, scouting schedules, and notes, many dated "1976," hand-labelled "Charley," and annotated in pen. Stickers featuring Ralph McQuarrie's "The Star Wars" logo and "Pre-Production Schedule" are affixed to the spine. They are peeling, and the paperwork exhibits edge wear and staple holes throughout. Dimensions: 25.5 cm x 30.5 cm x 2.5 cm (10" x 12" x 1")

Estimate. £800 - 1,200



1358
Charles Lippincott Collection: Teaser Style "B" One-Sheet
Star Wars: A New Hope (1977)

A teaser style "B" one-sheet from the promotion of George Lucas' Star Wars: A New Hope. Distributed by 20th Century Fox in Spring 1977, this second advance teaser poster was the first to feature both the correct Star Wars logo and the tagline "A long time ago in a galaxy far, far away.." coined by Lucas and Fox marketing executive David Weitzner. This original blue-and-white bordered glossy one-sheet comes from the collection of the film's advertising and publicity supervisor Charles "Charley" Lippincott. It exhibits tape residue in the upper right corner and crease lines from being rolled for storage. Dimensions: 68.75 cm x 104.25 cm (27" x 41")

Estimate. £1,000 - 1,500



1360
Hand-Drawn Storyboards and Annotated Production Materials for Promotional Featurette
Star Wars: A New Hope (1977)

Hand-drawn storyboards and annotated production materials for a promotional featurette for George Lucas' Star Wars: A New Hope. This lot comes from the collection of the film's advertising and publicity supervisor Charles "Charley" Lippincott and consists of a Kaleidoscope Films envelope with a photocopied production outline; a storyboard packet; a shot log packet; a log for EMI shot footage; and a narration script for Mark Hamill. The 17-page storyboards feature hand-drawn images on attached note cards, while the shot log packets feature 33 pages of photocopied annotations and handwritten corrections in the margins. These packets represent a rare insight into the behind-the-scenes documentary footage shot of the film during production. This lot exhibits discolouration, and notable photocopier marks. Dimensions: 21.75 cm x 35.75 cm x 1.5 cm (8.5" x 14" x 0.5")

Estimate. £2,000 - 3,000

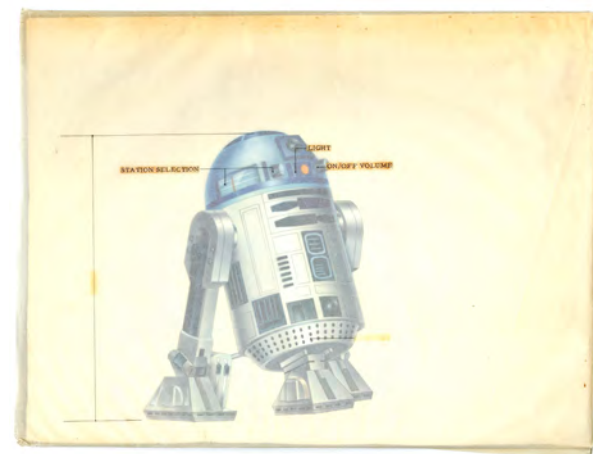

1359
Hand-Painted Concept Artwork for Japanese Coca-Cola R2-D2 Radio Product
Star Wars: A New Hope (1977)

Hand-painted concept artwork for an R2-D2 radio created and manufactured by Coca-Cola Japan to promote George Lucas' Star Wars: A New Hope. Coca-Cola released a limited number of R2-shaped AM radios for a sweepstakes in 1977. The original radio products are extremely rare. This lot comes from the collection of the film's advertising and publicity supervisor Charles "Charley" Lippincott, who was gifted it in Japan during the film's promotional world tour. It features a mixed media R2-D2 illustration rendered on paper and overlaid with vellum, then applied with printed labels reading "Station Selection," "Light," and "On/Off Volume." The artwork exhibits creasing and folding, and the labels are coming loose. Dimensions: 26.75 cm x 35.75 cm (10.5" x 14") Sold without copyright; see notice in the Buyer's Guide.

Estimate. £1,000 - 1,500



1361
Charles Lippincott Collection: Carrie Fisher-Signed and Hand-Annotated Children's Television Workshop Questionnaire
Star Wars: A New Hope (1977)

A questionnaire signed and hand-annotated by Carrie Fisher. Fisher was invited to appear in Puzzle Scene, an educational publication from Sesame Street production company Children's Television Workshop, to promote Star Wars: A New Hope. This five-page questionnaire comes from the collection of the film's advertising and publicity supervisor Charles "Charley" Lippincott, who managed Fisher's responses. It features a combination of Fisher's and Lippincott's handwritten, often satirical answers to personal questions in pen on Children's Television Workshop letterhead dated "March 30, 1977." The last page is a release form signed by Fisher. A paperclip binding the packet exhibits rusting from age. Dimensions: 21.75 cm x 28 cm (8.5" x 11")

Estimate. £1,000 - 1,500



1362
Alec Guinness Handwritten Postcard from the Tunisia Set
Star Wars: A New Hope (1977)

A postcard handwritten by Alec Guinness from the Tunisian set of George Lucas' Star Wars: A New Hope. Tunisia was the main shooting location for the planet Tatooine and Guinness sent this postcard to a relative during the production. The message is dated "Monday 22 March" and features a detailed account of the recent weather with Guinness signing "Alec" at the bottom. The picture on the front shows the ancient city of Carthage. The postcard has a crease down the middle and some discolouration from age. Dimensions: 10 cm x 14.5 cm (4" x 5 3/4")

Estimate. £800 - 1,200



1364
Alec Guinness and David Prowse Autographed Still
Star Wars: A New Hope (1977)

A still autographed by Alec Guinness and David Prowse from the promotion of George Lucas' Star Wars: A New Hope. Printed on glossy paper, the black-and-white still shows Obi-Wan Kenobi (Guinness) in a lightsaber duel with Darth Vader (Prowse). The image is autographed in silver-coloured ink by Prowse and pink ink by Guinness. The lot is accompanied by a certificate of authenticity from The Write Stuff Autographs. Dimensions: 20.5 cm x 25.5 cm (8" x 10")

Estimate. £1,000 - 1,500



1363
Carrie Fisher Owned and Autographed Portrait
Star Wars: Original Trilogy (1977 - 1983)

A photo portrait of Carrie Fisher, autographed and from her personal collection. This portrait was a private commission by Fisher and features the legendary Star Wars actress seated in an armchair in palatial surroundings with a playful smile on her face. The portrait has the signature of the photographer in the bottom left corner and has been framed for display and preservation. Fisher herself has autographed the reverse of the frame in black ink. The item comes with a letter of authenticity from the original sale, signed by Fisher and an associate of Sotheby's auction house. Dimensions: (Framed) 77.5 cm x 63 cm x 2 cm (30 1/2" x 24 3/4" x 3/4")

Estimate. £1,000 - 1,500



1365
Mark Hamill, Carrie Fisher, Alec Guinness and Cast Autographed Trilogy VHS Poster
Star Wars: Original Trilogy (1977 - 1983)

An autographed poster promoting the release of the original Star Wars trilogy on VHS, digitally remastered by THX, the company developed by Tomlinson Holman at Lucasfilm in 1983. This example is autographed in black and blue ink by more than 30 cast members, including Mark Hamill (Luke Skywalker), Carrie Fisher (Princess Leia), Alec Guinness (Obi-Wan Kenobi), David Prowse (Darth Vader), Peter Mayhew (Chewbacca), Anthony Daniels (C-3PO), Kenny Baker (R2-D2), Frank Oz (Yoda), Billy Dee Williams (Lando Calrissian), Ian McDiarmid (Emperor Palpatine) and Jeremy Bulloch (Boba Fett). The poster exhibits creasing around the edges, with marks and tape strips on the back. Dimensions: 84 cm x 59.5 cm (33" x 23 1/4")

Estimate. £2,000 - 3,000



1366
Mark Hamill and Cast
Autographed Photos †Δ
Star Wars: Original Trilogy
(1977 - 1983)

A set of four black-and-white autographed photos of the key cast members from the Star Wars original trilogy. The lot consists of a still of Luke Skywalker (Mark Hamill) from the Empire Strikes Back; a photograph of Kenny Baker stood next to R2-D2; a headshot of Peter Mayhew alongside a photo of Chewbacca; and a headshot of Anthony Daniels situated next to an image on C-3PO. Each actor has autographed their photograph with messages dedicated to special effects technician Roger Nichols. Dimensions (largest photos): 25.5 cm x 20.5 cm (10" x 8")

Estimate. £600 - 800



1367
Alec Guinness-autographed Photo †M
Star Wars: A New Hope (1977)

An Alec Guinness-autographed photo of Obi-Wan Kenobi from George Lucas' Star Wars - Ep IV - A New Hope. "Alec Guinness" is handwritten in black ink near the centre. The photo has some minor dents. Dimensions: 25 cm x 20 cm (9 3/4" x 7 3/4")

Estimate. £800 - 1,200



1368
Harrison Ford and Peter Mayhew
Autographed Photo †M
Star Wars: A New Hope (1977)

A Harrison Ford and Peter Mayhew autographed photo from the promotion of George Lucas' Star Wars: A New Hope. The photo, measuring 16" x 20", depicts the iconic space smuggler Han Solo (Harrison Ford) and his Wookiee companion Chewbacca (Peter Mayhew) posed in front of their spacecraft the Millennium Falcon. Ford has autographed the image in silver-coloured ink and Mayhew has signed the photo in blue ink. The lot features a sticker from OfficialPix, a company that acquired licensed autographed products. Dimensions: 51 cm x 41 cm (20" x 16")

Estimate. £600 - 800

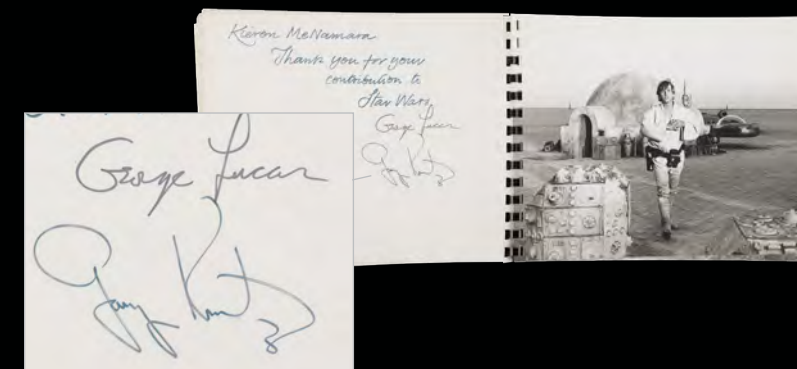

1369
Cast and Crew Photo Book Autographed by George
Lucas and Gary Kurtz †M
Star Wars: A New Hope (1977)

A cast and crew photo book from George Lucas' Star Wars: A New Hope. The book contains 25 black-and-white photos which depict key moments from the film in chronological order. The last page of the book contains a handwritten note thanking prop man Kieron McNamara for his contribution to the film. The note is signed by George Lucas and his co-producer Gary Kurtz. The front cover of the book has a sticker that uses the film's original title "The Star Wars". The photos are printed on photographic paper and are bound in a black cardboard cover with a black plastic spine. Two of the bindings on the spine are missing. Dimensions: 26 cm x 21 cm x 1.5 cm (10 1/4" x 8 1/4" x 1/2")

Estimate. £1,000 - 1,500



1371
Set of Five UKG and AFA Graded Boba Fett and
Stormtrooper Action Figures †
Star Wars: Original Trilogy (1977 - 1983)

A set of Boba Fett and Stormtrooper action figures, graded by the UK Graders (UKG) and Action Figure Authority (AFA), from the promotion of the original Star Wars trilogy. The lot includes an A New Hope Boba Fett mailer figure (UKG 85); a Return of the Jedi Boba Fett "Toy Toni" unpainted knee variant figure (AFA 90 NM+/MT); a Return of the Jedi Tri-Logo Boba Fett unpainted knee and painted dart variant figure (UKG 90); an A New Hope Stormtrooper SW12C figure; and a Return of the Jedi Argentinian Stormtrooper figure. Each toy comes in a protective plastic casing with its corresponding grading sticker adhered. The mailer Boba Fett figure comes with a note to consumers, a small catalogue and its original mailer box. Dimensions (largest): 6 cm x 35 cm x 17 cm (2 1/4" x 13 3/4" x 6 3/4")

Estimate. £1,500 - 2,500



1370
X-Wing and TIE Fighter Crew T-Shirt †Ω
Star Wars: A New Hope (1977)

An X-Wing and TIE fighter crew T-shirt from the production of George Lucas' Star Wars: A New Hope. Crew shirts with artwork by Ralph McQuarrie of a TIE fighter chasing an X-Wing through space were issued to select members of the production staff. This rare, white cotton Spruce shirt is printed on front with the colour X-Wing and TIE fighter graphic, but is not personalised on the reverse. It exhibits minor staining and fraying at the hem from wear.

Estimate. £250 - 350



1372
Deathstar Playset, X-Wing Fighter UKG75 and
Chewbacca SW12C UKG65 †
Star Wars: A New Hope (1977)

A Death Star playset, X-wing fighter (UKG 75) and Chewbacca SW12C action figure (UKG 65) from the promotion of George Lucas' Star Wars: A New Hope. Kenner originally released a large Death Star Space Station set in 1978 in the United States, but manufacturers in other countries decided not to produce it due to its size, choosing instead to create cardboard playsets, such as this one from Palitoy in the UK. The X-wing fighter and Chewbacca figure come in a protective plastic casing with their corresponding UK Graders (UKG) sticker adhered. The playset's box ends have been opened, and some of its components are missing. Dimensions (playset box): 32 cm x 61 cm x 8 cm (12 1/2" x 24" x 3 1/4")

Estimate. £1,500 - 2,500

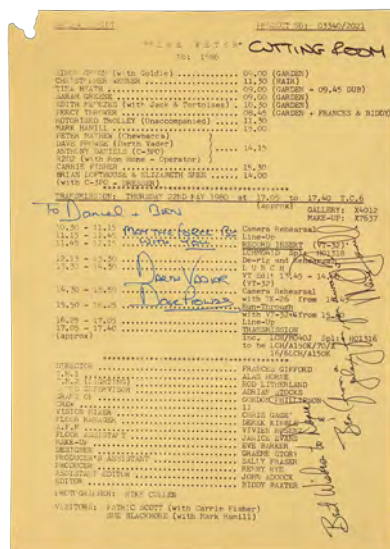

1373
 Mark Hamill and Dave Prowse Autographed Blue Peter Call Sheet
Star Wars: The Empire Strikes Back (1980)

A Blue Peter call sheet autographed by Mark Hamill (Luke Skywalker) and Dave Prowse (Darth Vader) from the promotion of Irvin Kershner's Star Wars: The Empire Strikes Back. Hamill, Prowse, Carrie Fisher (Leia Organa), Peter Mayhew (Chewbacca) and Anthony Daniels (C-3PO) appeared on the British children's television show Blue Peter to promote the film, with the episode airing on Thursday 22 May 1980. Both actors have addressed their messages to "Daniel" and "Ben", with Prowse writing, "May the force be with you, Darth Vader - Dave Prowse", and Hamill writing, "Best wishes to Daniel & Ben (from a galaxy far, far away!) Mark Hamill". The call sheet has a tear in the top left corner and a small piece of tape at the top. Dimensions: 29.5 cm x 21 cm (11 3/4" x 8 1/4")

Estimate. £600 - 800

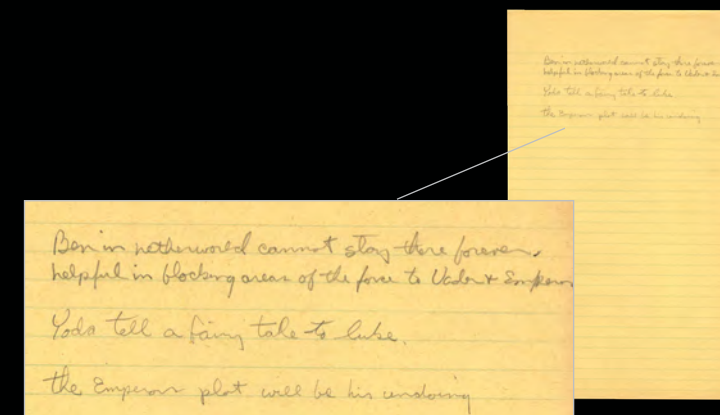

1376
 Handwritten George Lucas "Ben," "Yoda," and "Emperor" Story Notes
Star Wars: The Empire Strikes Back (1980)

Story notes handwritten by George Lucas circa the production of Irvin Kershner's Star Wars: The Empire Strikes Back. Likely written during the screenwriting stage, these notes make reference to several key characters' story arcs, including Obi-Wan "Ben" Kenobi (Alec Guinness) in the Jedi netherworld, Yoda (Frank Oz) telling Luke Skywalker (Mark Hamill) a fairytale, and Emperor Palpatine's (Ian McDiarmid) schemes. The notes are written in pencil in Lucas' distinctive script handwriting on U.S. legal-size lined paper. The page exhibits staining and folded corners and light discoloration from age. Dimensions: 21.75 cm x 35.75 cm (8.5" x 14")

Estimate. £2,000 - 3,000

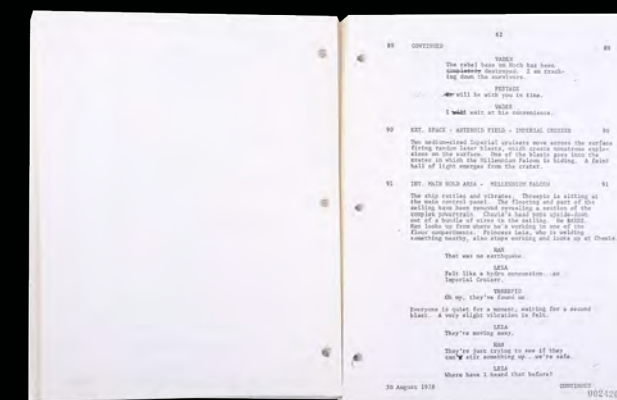

1377
 Bound Lucasfilm Research Library Third Draft Script
Star Wars: The Empire Strikes Back (1980)

A bound third draft script for Irvin Kershner's Star Wars: The Empire Strikes Back. Written by Leigh Brackett, this 135-page script was printed by the Lucasfilm Research Library for reference use. This brass brad-bound, three-hole-punched script features a Lucasfilm cover hand-marked "Empire 3rd Draft Aug '78," "Lucasfilm Research Library" stamped in blue ink above the credits on the first page, and various product numbers stamped on the revision pages. Annotations are printed throughout the margins. The cover exhibits some staining and the spine is bent from handling. Dimensions: 21.75 cm x 28 cm x 1.5 cm (8.5" x 11" x 0.5")

Estimate. £1,500 - 2,500



1374
 Irvin Kershner and Gary Kurtz Autographed Photo
Star Wars: The Empire Strikes Back (1980)

An autographed photo of director Irvin Kershner and producer Gary Kurtz on the set of Star Wars: The Empire Strikes Back. The behind-the-scenes colour image shows Kershner and Kurtz chatting in the snowy Finse, Norway, where the Hoth battle sequences were filmed. Both are dressed in the distinctive blue Norwegian crew jackets. Kershner has signed the image in blue marker at the bottom, and Kurtz has used black ink. Dimensions: 20 cm x 25.5 cm (8" x 10")

Estimate. £300 - 500



1378
 Hoth Battle Mini Storyboards Binder
Star Wars: The Empire Strikes Back (1980)

A set of mini storyboards from the production of Irvin Kershner's Star Wars: The Empire Strikes Back. Such storyboard sets were created as a reference for senior crew members while on set and on location. Presented in a small black binder, the lot consists of 212 printed storyboards depicting scenes from the introductory title crawl through to the rebels' evacuation of the ice planet Hoth. Many of the storyboards are dated at the top, with information printed below each illustration, including a short description, scene number, shot number and frame count. There is rust on the metal fastening, and one corner of the title page is missing. Dimensions: 18 cm x 23 cm x 5 cm (7" x 9" x 2")

Estimate. £800 - 1,200



1379
 AFA Graded Kenner Slave I and A-Wing Fighter
Star Wars: The Empire Strikes Back (1980) And Star Wars: Droids (1985)

A Slave I spaceship and A-Wing fighter vehicle, graded by the Action Figure Authority (AFA), from the promotion of Irvin Kershner's Star Wars: The Empire Strikes Back and the Lucasfilm animated television series Star Wars: Droids. Released in 1981 by Kenner, the Slave I spaceship (AFA 80 NM) comes housed inside its original box, which features a retail price sticker on the front and back. The Kenner A-Wing fighter (AFA (80 Q-NM) was produced in limited numbers, and the box states that the vehicle comes with one of the three Planetary Maps issued with products from their Power of Force line. Each toy comes in a protective plastic casing with its corresponding grading sticker adhered. Cracks are present on two sides of the Slave I's acrylic case. Dimensions (largest): 31 cm x 43 cm x 14.5 cm (12 1/4" x 17" x 5 3/4")

Estimate. £1,000 - 1,500



1375
 Pair of Hand-Drawn Ralph McQuarrie Novelization Cover Concept Artworks
Star Wars: The Empire Strikes Back (1980)

Two cover concept artworks hand-drawn by Ralph McQuarrie for the novelization of Irvin Kershner's Star Wars: The Empire Strikes Back. The novelization was written by Donald F. Glut and published in 1980 by Del Rey. These two concept artworks for the novelization's cover draw from production illustrations created by McQuarrie in 1979. One depicts Luke Skywalker's (Mark Hamill) Cloud City battle with Darth Vader (David Prowse), while the other depicts the title underneath two thumbnail sketches. The artworks are rendered in graphite, ink, and marker on drawing paper. Both are also featured on page 146 of the Abrams publication Star Wars Art: Ralph McQuarrie. They exhibit stray markings and bending. Dimensions (each): 30.5 cm x 21.75 cm (12" x 8.5") Sold without copyright; see notice in the Buyer's Guide.

Estimate. £3,000 - 5,000



1380
 12" Chewbacca Flat Box AFA 50 VG †Δ
Star Wars: The Empire Strikes Back (1980)

A rare 12" Chewbacca figure flat box from the promotion of Irvin Kershner's Star Wars: The Empire Strikes Back. In 1980, Kenner planned to continue its large-size, 12-inch action figure range, and one of the characters proposed was Chewbacca. However, the figure was never produced, and the only characters released in packaging bearing the Empire Strikes Back title artwork were IG-88 and Boba Fett, both of which were released in limited quantities. The flattened cardboard box comes in a plastic protective casing, with an Action Figure Authority (AFA) sticker featuring the toy's grading (50 VG) adhered to the casing's right side. The lot is accompanied by a Collectible Investment Brokerage certificate of authenticity. Dimensions: 65.5 cm x 44 cm x 3.5 cm (25 3/4" x 17 1/4" x 1 1/4")

Estimate. £3,000 - 5,000



1381
 Stuart Freeborn Collection: Ewok Production Costume Components †Δ
Star Wars: Return Of The Jedi (1983)

A set of Ewok costume components from the production of Richard Marquand's Star Wars: Return of the Jedi. These components originally came from the collection of legendary make-up artist Stuart Freeborn. The set comprises three fur samples; two paper sheets featuring fur samples; four plastic dome eyes (two labelled "R"); teeth and denture moulds; and various unfinished foam-latex prosthetic pieces. The foam-latex components include a full face mask, two ears, four hollow toe castings, and a solid casting of a tiny foot. There are signs of discolouration, and some samples are missing from the paper. Dimensions (largest component): 28 cm x 25 cm x 12 cm (11" x 9 3/4" x 4 3/4")

Estimate. £1,000 - 1,500



1382
 Production-made Anakin Skywalker (Sebastian Shaw) Scars †Δ
Star Wars: Return Of The Jedi (1983)

Production-made Anakin Skywalker (Sebastian Shaw) scars from Richard Marquand's Star Wars: Return of the Jedi. Scars were created by acclaimed makeup special effects artist Stuart Freeborn and these originated from his collection. Makeup appliances were used to create the look of Anakin's scarred face after it is revealed beneath the Darth Vader helmet. The scars are made from foam latex and remain uncut and unpainted. They closely resemble the scars seen on Anakin's left cheek. Dimensions: 23.5cm x 18 cm x 1.5 cm (9 1/4" x 7" x 1/2")

Estimate. £800 - 1,200

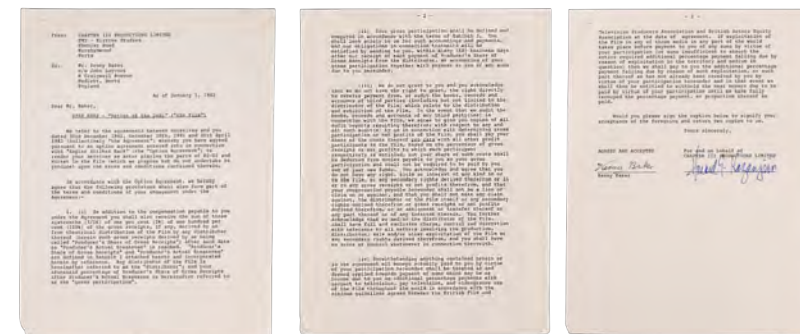

1383
 Kenny Baker Estate Collection: Kenny Baker and Howard Kazanjian-signed Chapter III Productions Contract †M
Star Wars: Return Of The Jedi (1983)

Kenny Baker's signed three-page contract from the production of Richard Marquand's Star Wars: Return of the Jedi. This lot comes from the estate of renowned actor Kenny Baker. Drafted by Chapter III Productions Limited, the contract features several typed paragraphs detailing Baker's agreement to reprise the role of beloved droid R2-D2 in Return of the Jedi, as well as play a new character, the Ewok named Wicket. However, after Baker fell ill on the first day of shooting, the role of Wicket was given to Warwick Davis. Dated "January 1, 1982", the contract is signed at the bottom of the third page in black ink by Baker, and in blue ink by producer Howard Kazanjian. The contract displays creasing and staple holes. Dimensions: 28 cm x 21.5 cm (11" x 8 1/2")

Estimate. £2,000 - 3,000



1384
 Main Cast-autographed Lobby Card †M
Star Wars: Return Of The Jedi (1983)

A lobby card autographed by the main cast of Richard Marquand's Star Wars: Return of the Jedi. The lobby card is autographed in silver pen by Mark Hamill, Carrie Fisher, Harrison Ford, Peter Mayhew and Anthony Daniels, all of whom appear on the card. It has some very minor edgewear. Dimensions: 28 cm x 35.5 cm (11" x 14")

Estimate. £1,500 - 2,500



1385
 "Revenge of the Jedi" Teaser One-Sheet †Ω
Star Wars: Return Of The Jedi (1983)

A "Revenge of the Jedi" teaser one-sheet from the promotion of Richard Marquand's Star Wars: Return of the Jedi. Early teaser posters illustrated by artist Drew Struzan featured the film's original title, "Revenge of the Jedi," before it was replaced with the final title. This glossy, full-colour one-sheet featuring Luke Skywalker (Mark Hamill) and Darth Vader (David Prowse) duelling under the tagline "The Saga Continues" comes from the collection of producer Howard Kazanjian. It exhibits some creasing from being rolled for storage. Dimensions: 68.75 cm x 104.25 cm (27" x 41")

Estimate. £1,000 - 1,500



1386
MTV-7 Revenge Box Flat AFA 75+ +
Star Wars: Return Of
The Jedi (1983)

An MTV-7 Multi-Terrain vehicle box flat box from the promotion of Richard Marquand's Star Wars: Return of the Jedi. This example bears a Revenge of the Jedi logo, the production's original title, making it highly desirable. The film's title was changed to Return of the Jedi before any toys from the line were released and distributed to stores. The flattened cardboard box comes in a plastic protective casing, with an Action Figure Authority (AFA) sticker featuring the toy's grading (75+ EX+/NM) adhered to the casing's bottom side. Dimensions: 39.5 cm x 35 cm x 3.5 cm (15 1/2" x 13 3/4" x 1 1/4")

Estimate. £800 - 1,200



1389
Propshop Limited Edition Melted Darth Vader
Helmet Replica †Δ
Star Wars: The Force Awakens (2015)

A limited edition Propshop replica of the melted Darth Vader helmet from J.J. Abrams' Star Wars: The Force Awakens. In the film, Kylo Ren (Adam Driver) brooded over the charred remains of Lord Vader's (David Prowse) helmet. Propshop, the industry prop and set decoration fabricator who created many props for The Force Awakens, released only 500 made-to-order, 3D-printed replicas of the melted helmet in partnership with Disney and Lucasfilm. Made from original 3-D scan data from the production to ensure accuracy, this helmet is constructed of a range of proprietary synthetic materials, hand-painted in Vader's signature charcoal-black, sanded and affixed with metal details near the damaged breathing apparatus. Also included is a display stand with a plaque. Dimensions (displayed): 46 cm x 30 cm x 41 cm (18" x 11 3/4" x 16 1/4")

Estimate. £800 - 1,200



1390
Propshop Limited Edition Chewbacca
Bowcaster Replica †Δ
Star Wars: The Force Awakens (2015)

A limited edition Propshop replica of Chewbacca's (Peter Mayhew) bowcaster from J.J. Abrams' Star Wars: The Force Awakens. Propshop, the industry prop and set decoration fabricator which created many props for The Force Awakens, released made-to-order, 3D-printed replicas of Chewie's bowcaster in partnership with Disney and Lucasfilm. The pieces were made from original 3D-scan data from the production to ensure the utmost accuracy. This black bowcaster is made of high-density resin with metal and acrylic elements. It features a binocular scope, circular side greebles, a pullable trigger, and a green woven strap with metal clips. There are signs of minor repair work on the stock. Dimensions: 80 cm x 78 cm x 24 cm (31 1/2" x 30 3/4" x 9 1/2")

Estimate. £800 - 1,200



1387
Collection of Crew Apparel
and Poster M
Star Wars: Revenge Of The Sith
(2005)

A collection of crew apparel and a poster from George Lucas' Star Wars: Revenge of the Sith. The set comprises a black heavyweight fabric Driza-bone® jacket (size L); a black cotton fleece (size 14); a black cotton sleeveless fleece (size XL); a black cotton long-sleeve polo shirt (size S); a black cotton T-shirt with "Revenge of the Sith" printed in red (size L); a black cotton T-shirt with "Documentary Crew" embroidered on the left breast (size S); and a crew poster depicting photos of the various departments that worked on the production. Dimensions (poster): 82 cm x 55 cm (32 1/4" x 21 3/4")

Estimate. £600 - 800

1388
Captain Phasma (Gwendoline
Christie) Production
Reference Helmet †Δ
Star Wars: The Force Awakens
(2015)

A Captain Phasma (Gwendoline Christie) art reference helmet from the production of J.J. Abrams' Star Wars: The Force Awakens. The commander of the First Order's stormtroopers wore distinctive silver-coloured chrome armour, a costume design initially proposed for Kylo Ren. This helmet was used as reference by the art department during production, while creating the final design. The helmet is made of 3D-printed resin with a muted silver chrome-like finish, black acrylic lenses in the eye recesses, and mesh grill detailing. The lot displays intentional distressing to the finish and minor cracks on the underside of the neck. Dimensions: 31 cm x 28.5 cm x 30 cm (12 1/4" x 11 1/4" x 11 3/4")

Estimate. £3,000 - 5,000



1391
Propshop Kylo Ren Battle-worn Helmet Replica †Δ
Star Wars: The Force Awakens (2015)

A limited edition Propshop replica of Kylo Ren's (Adam Driver) battle-worn helmet from J.J. Abrams' Star Wars: The Force Awakens. Propshop, the industry prop and set decoration fabricator who created many props for The Force Awakens, released made-to-order, 3D-printed helmet replicas in partnership with Disney and Lucasfilm. The pieces were made from original 3D scan data from the production to ensure the utmost accuracy, and this helmet is constructed of a range of proprietary synthetic materials. It has a padded lining and a black mesh insert on the inside of the visor. The helmet has been expertly hand-painted, with silver-coloured inlay detailing and intentional weathering applied. The lot comes with a black plastic display stand with a plaque. Dimensions (displayed): 34 cm x 23.5 cm x 50 cm (13 1/2" x 9 1/4" x 19 3/4")

Estimate. £600 - 800



1392
Propshop Limited Edition Kylo Ren Lightsaber Replica †Δ
Star Wars: The Force Awakens (2015)

A Propshop limited edition replica of Kylo Ren's (Adam Driver) lightsaber from J.J. Abrams' Star Wars: The Force Awakens. Propshop, the industry prop and set decoration fabricator who created many props for The Force Awakens, released made-to-order, limited edition replicas in partnership with Disney and Lucasfilm. The pieces were made from original 3D scan data from the production to ensure the utmost accuracy. This crossguard lightsaber hilt is made of aluminium expertly hand-painted to appear weathered, with metal and high-density resin elements. Also included is a display stand with a plaque featuring the film's title artwork and a custom wood crate featuring Lucasfilm's logo and the film logo. Dimensions (displayed): 20.5 cm x 15 cm x 30 cm (8" x 6" x 11 3/4"); (box): 62 cm x 33 cm x 21 cm (24" x 13" x 8 1/4")

Estimate. £500 - 700





1393
Propshop Limited-edition Rey Lightsaber Replica †Δ
Star Wars: The Force Awakens (2015)

A Propshop limited-edition replica of Rey's (Daisy Ridley) lightsaber from J.J. Abrams' Star Wars: The Force Awakens. Propshop, the industry prop and set decoration fabricator which created many props for The Force Awakens, released made-to-order limited-edition replicas in partnership with Disney and Lucasfilm. The pieces were made from original 3D scan data from the production to ensure the utmost accuracy. This lightsaber hilt is made of aluminium and steel expertly hand-painted to appear weathered, with high-density resin detailing and six dense black rubber strips. Also included is a display stand with a plaque bearing the film's title. Some of the black rubber strips have begun to peel. Dimensions (displayed): 20.5 cm x 9 cm x 30 cm (8" x 3 1/2" x 11 3/4")

Estimate. £500 - 700



1394
Set of Crew Apparel M
Star Wars: The Force Awakens (2015)

A set of apparel made for the Industrial Light and Magic VFX crew from the production of J.J. Abrams' Star Wars: The Force Awakens. The lot comprises a black nylon First Order emblem jacket; a light grey Resistance Superbird emblem jacket; a black Elevate "VII" polyester gilet; a blue T-shirt decorated with a reworking Ralph McQuarrie triangle Star Wars logo; and a white T-shirt featuring a printed copy of an X-Wing storyboard. All five garments are labelled as size XL and remain in an unworn condition.

Estimate. £400 - 600

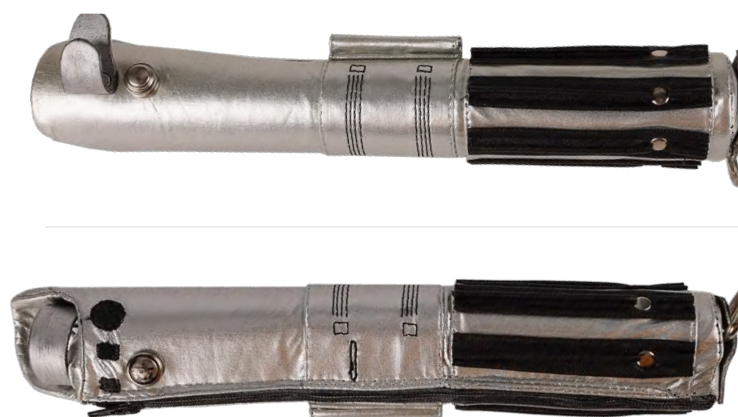

1397
Prototype Luke Skywalker Lightsaber Pencil Case †Δ
Star Wars: The Force Awakens (2015)

A prototype lightsaber pencil case from the promotion merchandising of J.J. Abrams' Star Wars: The Force Awakens. A multitude of merchandise was designed and manufactured on the film's release, but some items, such as this pencil case, never made it to retail. The pencil case is made from silver stretch fabric and faux leather, with a real leather interior. It is designed to resemble Luke Skywalker's lightsaber, with intricate, hand-embroidered details and metal fixtures. The interior is hollow and the pencil case opens with a metal zip. Dimensions: 30 cm x 7 cm x 4.5 cm (11 3/4" x 2 3/4" x 1 3/4")

Estimate. £300 - 500



1398
Art Department Crew Parka M
Star Wars: The Rise Of Skywalker (2019)

An art department crew parka from the production of J.J. Abrams' Star Wars: The Rise of Skywalker. The Regatta Great Outdoors parka jacket is made of black polyester, with a zip fastening down the front and a faux-fur trim on the hood. A large embroidered patch featuring an emblem of Kylo Ren's helmet with the text "Star Wars, Episode IX, Art Dept" decorates the left breast pocket. Two different coloured patches are sewn to the shoulders. The jacket is labelled as a UK size "M" and displays minor marks.

Estimate. £400 - 600



1395
Harrods Limited Edition BB8 Model †Δ
Star Wars: The Force Awakens (2015)

A Harrods limited-edition BB8 model from the promotion of J.J. Abrams' Star Wars: The Force Awakens. The small brass model was created by PropShop and comes in a protective box with "By Exclusive Invitation from Harrods" on the magnetic lid. The box has some minor wear from storage. Dimensions: 4.5 cm x 4.5 cm x 7.5 cm (1 3/4" x 1 3/4" x 3")

Estimate. £400 - 600



1396
Set of Three Crew Jackets †Δ
Star Wars: The Force Awakens (2015), Rogue One: A Star Wars Story (2016) And Solo: A Star Wars Story (2018)

A set of three crew jackets from the productions of J.J. Abrams' Star Wars: The Force Awakens, Gareth Edwards' Rogue One: A Star Wars Story and Ron Howard's Solo: A Star Wars Story, respectively. The lot comprises a padded black "Star Wars VII, SFX Crew 2014" gilet; a black "Rogue One: A Star Wars story" fleece-lined jacket with a "Hat Trick Catering" patch embroidered on the left breast; and a black polyester "Solo, ILM VFX, 2018" bomber-style jacket. All three clothing items are marked size M.

Estimate. £400 - 600



1.15 m
(3.75')

1399
Harrods "Star Wars Gallery" Destroyed Darth Vader
Helmet Acrylic Screen Print †Δ
Star Wars: The Force Awakens (2015)

A large destroyed Darth Vader helmet screen print from the promotion of J.J. Abrams' Star Wars: The Force Awakens. This print was created exclusively for the Star Wars Gallery showcased in London department store Harrods in 2016, and was displayed alongside authentic replica props from The Force Awakens. Each exhibition item was created by Propshop, the company responsible for the film's original props. The weighty white acrylic sheet shows a detailed screen print of Darth Vader's destroyed helmet, as seen when Kylo Ren (Adam Driver) speaks to it and asks for forgiveness. There is a hole in each corner where the artwork was mounted. Dimensions: 114.5 cm x 114.5 cm x 1 cm (45" x 45" x 1/2") Special shipping required; see special shipping notice in the Buyer's Guide.

Estimate. £1,000 - 1,500



1.15 m
(3.75')

1400
Harrods "Star Wars Gallery" Captain Phasma Helmet
Acrylic Screen Print †Δ
Star Wars: The Force Awakens (2015)

A large Captain Phasma helmet screen print from the promotion of J.J. Abrams' Star Wars: The Force Awakens. This print was created exclusively for the Star Wars Gallery showcased in London department store Harrods in 2016, and was displayed alongside authentic replica props from The Force Awakens. Each exhibition item was created by Propshop, the company responsible for the film's original props. The weighty white acrylic sheet shows a detailed screen print of the chrome-plated helmet donned by the First Order captain. There is a hole in each corner where the artwork was mounted within the gallery. Dimensions: 114.5 cm x 114.5 cm x 1 cm (45" x 45" x 1/2") Special shipping required; see special shipping notice in the Buyer's Guide.

Estimate. £1,000 - 1,500

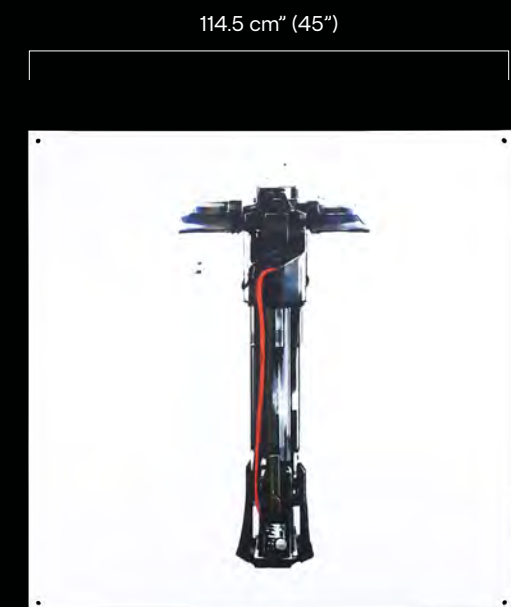

1401
Harrods "Star Wars Gallery" Kylo Ren
Lightsaber Acrylic Screen Print †Δ
Star Wars: The Force Awakens
(2015)

A large Kylo Ren lightsaber screen print from the promotion of J.J. Abrams' Star Wars: The Force Awakens. This print was created exclusively for the Star Wars Gallery showcased in London department store Harrods in 2016, and was displayed alongside authentic replica props from The Force Awakens. Each exhibition item was created by Propshop, the company responsible for the film's original props. The weighty white acrylic sheet shows a detailed screen print of Kylo Ren's (Adam Driver) lightsaber hilt showing its distinctive crossguard design. There is a hole in each corner where the artwork was mounted within the gallery. Dimensions: 114.5 cm x 114.5 cm x 1 cm (45" x 45" x 1/2") Special shipping required; see special shipping notice in the Buyer's Guide.

Estimate. £1,000 - 1,500



1402
Stormtrooper Promotional 1:1
Statue †Δ
Star Wars: Rebels (2014)

A life-size Stormtrooper statue display from the promotion of the Lucasfilm animated television series Star Wars Rebels. Muckle Mannequins produced two variations of limited-edition promotional Stormtrooper statues, one with straight arms (known as "RE-STO-1") and one with bent arms (known as "RE-STO-2"). Made of fibreglass, the statue has been sculpted to resemble the uniform worn by Imperial stormtroopers and comes with a blaster rifle positioned in both hands. The figure comes presented on a custom-made rectangular base which is missing its plaque, and there are some minor chips to the blaster. Dimensions: 54 cm x 70 cm x 192 cm (21 1/4" x 27 1/2" x 75 1/2") Special shipping required; see special shipping notice in the Buyer's Guide.

Estimate. £1,000 - 1,500



1403
Collection of Crew Gear †Δ
Star Wars: The Rise Of Skywalker
(2019)

A collection of crew gear from the production of J.J. Abrams' Star Wars: The Rise of Skywalker. The lot comprises a black BB-8 "Jordan 2018" T-shirt (size S); a black T-shirt featuring a keyboard design (size S); a green "Trixie" logo T-shirt (size S); a white "Trixie" record design T-shirt (size M); a padded jacket featuring "IX" embroidered in yellow on the right sleeve (size M); a black stainless steel water bottle; two black caps and two "IX" gift bags. The original tags are still attached to the jacket's zip. Dimensions (gift bag): 42 cm x 36 cm x 10 cm (16 1/2" x 14 1/4" x 4")

Estimate. £400 - 600



1404
Set of Four Costume Continuity Polaroids and a
Costume Sketch † M
Stargate (1994)

A set of four costume continuity Polaroids and a costume sketch from the production of Roland Emmerich's sci-fi adventure film Stargate. Two photographs feature Horus (Djimon Hansou) carrying a spear and wearing a mask with an ornate falcon-head motif. The other two photographs feature Anubis (Carlos Lauchu) carrying a spear; in one, he also sports an intricately designed jackal mask. Scene numbers and character names are handwritten on all four photographs. The costume sketch comprises a single sheet of plain A4 paper, upon which handwritten notes and drawings detail various Anubis costume elements across 24 scenes. Dimensions (costume sketch): 28 cm x 21.5 cm (11" x 8 1/2") Sold without copyright; see copyright notice in the Buyer's Guide.

Estimate. £400 - 600



1406
Goa'uld Ship UGDO Panel Ω
Stargate SG-1 (T.V. Series, 1997 - 2007)

A Goa'uld ship UGDO panel from the sci-fi action series Stargate SG-1. Goa'uld ships were lined with panels known by production as UGDOS, or Universal Garage Door Openers, due to their use on multiple Goa'uld sets throughout the series. This panel features components added for the Season 6 "Descent," including an art deco-inspired cover, a rare ornately designed interior portion behind the front plate, and eight removable multicolour pegs. Also included is a Stargate Propshop Certificate of Authenticity. The lot exhibits wood splintering, scratches, and faded and chipped paint from production. Dimensions: 31.75 cm x 43.25 x 14 cm (12.5" x 17" x 5.5")

Estimate. £1,000 - 1,500



1405
Jack O'Neill's (Richard Dean
Anderson) Costume Display M
Stargate SG-1
(T.V. Series, 1997 - 2007)

Colonel Jack O'Neill's (Richard Dean Anderson) costume from the sci-fi television show Stargate SG-1. This costume was created for Season 10, but was ultimately not seen on screen. Anderson left the show after Season 8, only making guest appearances during Seasons 9 and 10. The uniform consists of a cap (labelled "NIC"); a green zip-up jacket; a pair of matching cargo trousers (labelled "Stargate 12" and "O'Neil" [sic]); a green Nylon belt; and a pair of size 12 black leather combat boots (labelled "Stargate 12" and "O'Neil" [sic]). An "SG1" patch adorns the right sleeve of the jacket, with an Earth emblem patch on the left sleeve, and an additional patch is missing from the Velcro rectangle above the left chest pocket. The costume is presented on a custom-made display which features the production title on its base, and is accompanied by a MGM certificate of authenticity. Dimensions (displayed): 39 cm x 55 cm x 212 cm (15 1/4" x 21 1/2" x 83 1/2") Special shipping required; see special shipping notice in the Buyer's Guide.

Estimate. £2,500 - 3,500



1407
President Henry Hayes' (William Devane) Binder with
Khalek (Neil Jackson) Paperwork Ω
Stargate SG-1 (T.V. Series, 1997 - 2007)

President Henry Hayes' (William Devane) binder with Khalek (Neil Jackson) paperwork from the sci-fi television series Stargate SG-1. In Season 7, President Hayes was inaugurated and briefed from binders in the White House. In Season 9, SG-1 studied Khalek's unusual Goa'uld/human hybrid genetics. This lot consists of a black vinyl three-ring binder labelled "President of the United States"; two colour-printed "Genetic Report Analysis" pages labelled "Khalek"; seven printed memoranda labelled "Henry Hayes"; an Air Force business card; and five memoranda labelled "House of Representatives." The paperwork exhibits staining, tearing, and hole-punching from production. Dimensions: 26 cm x 29.5 cm x 4 cm (10.25" x 11.75" x 1.5")

Estimate. £400 - 600



1408
Colonel John Sheppard's
(Joe Flanigan) Costume
Display M
Stargate Atlantis
(T.V. Series, 2004 - 2009)

Colonel John Sheppard's (Joe Flanigan) costume from sci-fi TV series Stargate: Atlantis. Sheppard wore his duty uniform during the first three seasons. The costume comprises a grey nylon-and-polyester jacket with matching trousers; a tactical vest; and a pair of leather boots (size "10.5"). The right sleeve of the jacket features an "Atlantis" patch, and the left sleeve an American flag patch. The trousers have a label in the waistband reading "Sheppard" and are size "M/31". The tactical vest features multiple pockets, several of which contain field-dressing packets. The costume is displayed on a custom-built stand featuring the show's title, and is accompanied by two certificates of authenticity from MGM. Dimensions (display): 38 cm x 55 cm x 183 cm (15" x 21 3/4" x 72") Special shipping required; see special shipping notice in the Buyer's Guide.

Estimate. £1,500 - 2,500



1409
Pair of Model-miniature
TAC Fighters M
Starship Troopers
(1997)

A pair of model-miniature TAC fighters from Paul Verhoeven's sci-fi action film Starship Troopers. TAC fighters were the primary combat aircraft of the United Citizen Federation Fleet, notably used during bombing missions against the Arachnids. These model miniatures are made of resin and feature windows and other exterior details hand-coloured in black, red and green pens. One of the models is missing a back wing that has snapped off. This appears to have also occurred to the other model but has been glued back in place. Dimensions: (each fighter) 5 cm x 7cm x 1.5 cm (2" x 2 3/4" x 1/2")

Estimate. £800 - 1,200



1412
Lenny Nero's (Ralph Fiennes) Coat M
Strange Days (1995)

Lenny Nero's (Ralph Fiennes) ornate coat from Kathryn Bigelow's sci-fi thriller Strange Days. Nero carefully chose a coat from his wardrobe and wore it for most of the film, at one point commenting on its expensiveness in a conversation with nightclub bouncer Wade Beemer (Michael Jace). Marked "Fox" on its interior, the coat is a patchwork of soft leather and suede with reptile-skin textures and a crimson velvet section beneath the collar. Two of the coat buttons are missing, there are some minor scuff marks at the base of the coat, and the back of the collar has faded.

Estimate. £1,000 - 1,500



1413
Vial of Green Goo O
Stranger Things
(T.V. Series, 2016 - 2022)

A canister of green goo from sci-fi horror TV series Stranger Things. In Season 3, Steve (Joe Keery) and Dustin (Gaten Matarazzo) discovered a glass canister filled with a mysterious green substance while infiltrating the Russian base hidden beneath Hawkins' Starcourt Mall. This canister comprises a clear flexible plastic inner tube set inside a cast-resin-and-rubber casing with a handle at the top, which has been painted to imitate metal. The inner tube is filled with a thick green substance and includes an oval LED light that would have been activated on set to give the goo a glowing radioactive look. The LED light is suspended in the goo and features a strip of tape at the back, indicating it adhered to either the top or bottom of the canister at one point. It is believed that only one canister known to be made for production, as it was duplicated on screen using CGI. Accompanying this lot is a Celebrity Authentics letter of authenticity from a production member who worked on the series. Dimensions: 10.5 cm x 11.5 cm x 27.5 cm (4 1/4" x 4 1/2" x 10 3/4")

Estimate. £3,000 - 5,000



1414
Pin-Up Girl's (Laura Margolis) Mask M
Strangers, The (2008)

Pin-Up Girl's (Laura Margolis) mask from Bryan Bertino's horror film The Strangers. Three mask-wearing strangers spent a night tormenting Kristen (Liv Tyler) and James (Scott Speedman). This vacuum-formed plastic mask is shaped and hand-painted to resemble a girl with a Clara Bow-style bob haircut. The face is painted with a light creme base, with pink rosy cheeks and eye shadow. There are holes in the eyes and two small breathing holes in the nose. Each side of the mask has a small hole for string. Dimensions: 24 cm x 18 cm x 10 cm (9 1/2" x 7" x 4")

Estimate. £3,000 - 5,000



1410
Battle-Damaged Corvette
Transport Model Miniature O
Starship Troopers (1997)

A battle-damaged Corvette Transport model miniature from Paul Verhoeven's sci-fi satire Starship Troopers. The cornerstone of the Federation fleet, UCF Corvettes came under heavy attack during the failed invasion of Klendathu. Constructed by Sony Pictures Imageworks' Thunderstone model shop, this highly detailed model miniature is made from cast resin painted green and grey. Plasma damage is visible on the hull, and burn marks are applied in blue and purple to the sides. There is a hole in the bottom for mounting to a post, and the model exhibits scuffed paint, exposing the resin. Dimensions (displayed): 16.5 cm x 5 cm x 3.25 cm (6.5" x 2" x 1.25")

Estimate. £1,500 - 2,500



1411
Mobile Infantry
Helmet O
STARSHIP TROOPERS
(1997)/CRUSADE (T.V.
SERIES, 1999)

A Mobile Infantry helmet from Paul Verhoeven's sci-fi satire Starship Troopers. Mobile Infantry troopers wore their standard-issue helmets throughout training, in propaganda videos, and during their planet-hopping campaign against the Arachnids. This foam-padded fibreglass helmet is painted green-grey with Mobile Infantry logos on the front and back, mounted with a resin sight, and affixed at the neck with a black foam chin strap. Also included is a clear plastic visor which has come loose from the helmet since production. Its current paint scheme and accessories were added for the production of J. Michael Straczynski's Babylon 5 spin-off series Crusade, in which members of the Earthforce armed forces wore standard-issue helmets. The helmet is hand-numbered "8" in two places on the interior and exhibits scratching, small fractures in the fibreglass, and flaking paint from production wear and age.

Estimate. £600 - 800



1415
Dollface (Gemma Ward) Mask M
Strangers, The (2008)

A Dollface (Gemma Ward) mask from Bryan Bertino's horror film The Strangers. Three masked strangers spent a night tormenting Kristen (Liv Tyler) and James (Scott Speedman). This vacuum-formed plastic mask is shaped and hand-painted to resemble the face of a china doll. It features large holes in the eyes and a small hole in the mouth. It is an early version of the final design and features some slight differences, including the shape of its cheeks and the placement of its eyebrows. Each side of the mask has a small hole for string. Dimensions: 21 cm x 17 cm x 6.5 cm (8 1/4" x 6 3/4" x 2 1/2")

Estimate. £3,000 - 5,000



1416
SFX "The Stuff", Small Container and Large Container
Autographed by Larry Cohen M
Stuff, The (1985)

A pair of "The Stuff" containers from Larry Cohen's satirical horror The Stuff. A delicious and mysterious goo was discovered oozing out of the earth, then marketed as the newest dessert sensation The Stuff. However, it turned its consumers into zombie-like snackers. "The Stuff" branded containers were seen throughout the movie. The lot comprises a small "The Stuff" container made of paper; a hardened piece of foam putty moulded to look like a poured liquid; and a large "The Stuff" container autographed by director Cohen in black ink. The items show minor discoloration and dirt from age. Dimensions (large container): 15.5 cm x 11 cm x 11 cm (6" x 4 1/4" x 4 1/4")

Estimate. £800 - 1,200



1417
Deadshot's (Will Smith) ZEV Pistol and Magazines Ω
Suicide Squad (2016)

Deadshot's (Will Smith) ZEV pistol and magazines from David Ayer's superhero film Suicide Squad. Deadshot wielded his signature pistol when he faced off against the Enchantress (Cara Delevingne) and Incubus (Alain Chanoine). This lot consists of a custom-designed black plastic pistol modelled from a ZEV handgun and painted maroon and gold-colour with a shiny textured grip and two removable black plastic magazines with gold-painted tops. Each component is intentionally distressed by production to appear well-used with scratches and paint lines. Dimensions: 26.75 cm x 18.5 cm x 4 cm (10.75" x 7.5" x 1.75") Ownership may be restricted in some countries; see replica firearm notice in Buyer's Guide.

Estimate. £1,200 - 1,800



1418
A.R.G.U.S. Pneumatic Tracker/Detonator Injector Gun Ω
Suicide Squad (2016)

An A.R.G.U.S. pneumatic tracker/detonator injector gun from David Ayer's superhero film Suicide Squad. Amanda Waller's (Viola Davis) team used injector guns to put tracker bombs in antiheroes' necks. This static injector gun is made of black and steel-colour metal with rubber components and a compressing trigger. Painted in white onto one side of the gun are numbers, a futuristic barcode, and a dial indicator. The metal is finished with black paint to mimic a gritty appearance. It exhibits minor scratching on the metal from production. Dimensions: 28 cm x 18.5 cm x 2.75 cm (11" x 7.75" x 1.25")

Estimate. £800 - 1,200



1420
Starro Spore Background Mask Ω
Suicide Squad, The (2021)

A Starro spore background mask from James Gunn's superhero sequel The Suicide Squad. After Starro escaped from imprisonment, it shed spores that latched onto unsuspecting people from Corto Maltese. Designed specifically for background performers, this grey plastic mask features holes for leather cording, a pink and blue starfish pattern with a single eyeball at the centre, and "BG016" labelled on the interior. The bottom has been cut and filled with plastic mesh for visibility. The mask exhibits scratches from production and wear, and glue residue on the mesh.

Estimate. £1,000 - 1,500



1419
Captain Boomerang's (Jai Courtney) Boomerang Ω
Suicide Squad (2016)

Captain Boomerang's (Jai Courtney) boomerang from David Ayer's superhero film Suicide Squad. George Harkness, aka Captain Boomerang, used his signature high-tech boomerang throughout the film. This static boomerang is made of cast resin and painted a solid grey. It features bevelling on both arms to appear blade-like with leading edges designed to look sharp and blunt trailing edges. The inner elbow features an asymmetrical cutout. The boomerang exhibits small scratches, cuts, and paint lines from production use. Dimensions: 40.75 cm x 7.75 cm x 0.75 cm (16" x 3" x 0.25")

Estimate. £400 - 600



1421
Spacesuit Boots ±Δ
Sunshine (2007)

A pair of spacesuit boots from Danny Boyle's sci-fi thriller Sunshine. Capa (Cillian Murphy) and Kaneda (Hiroyuki Sanada) both wore their spacesuits and boots while repairing the shield panels on the spaceship Icarus II. The boots are made of fibreglass painted gold. Each features a metal cuff with a metallic vinyl trim, and has a metal stand fastened to its base, which protrudes out of the boot. The upper and lower sections of the boots are separate pieces, attached via a hinge on either side, to allow the ankle and calf to flex. The left boot has a woven nylon fabric lining, while the right features a metallic grid sole. Both boots have been intentionally distressed for production and exhibit additional abrasions to the paintwork, rusting to the metal stands, and dust from storage. Dimensions (each boot): 41 cm x 26 cm x 45 cm (16" x 10 1/4" x 17 3/4")

Estimate. £800 - 1,200

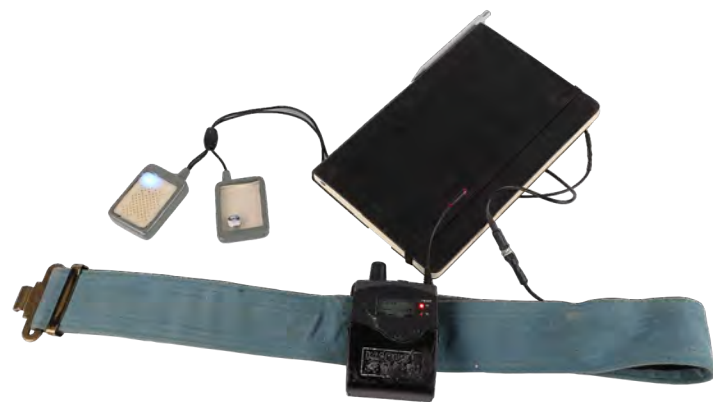

1422
Corazon's (Michelle Yeoh) Diary and Capa's (Cillian Murphy) Hero Light-up Communicator + Sunshine (2007)

Corazon's (Michelle Yeoh) diary and Capa's (Cillian Murphy) hero light-up communicator from Danny Boyle's sci-fi thriller Sunshine. Botanist Corazon had her diary with her during the conversation about making a rendezvous with the original Icarus mission ship, and Capa wore his communicator for much of the film. The black Moleskin® diary features handwritten notes and doodles in Yeoh's own hand, including information about plants, thoughts on her character, and a partial diary of the production. The communicator features a blue belt with a transceiver connected to a pair of grey resin dog tag communicators. When activated, the transceiver screen illuminates and displays Capa's name. The communicator has some wear from use, including cracks and adhesive remnants. The Icarus II logo on the transceiver is heavily scratched. Dimensions (diary): 21 cm x 13 cm x 2 cm (8 1/4" x 5" x 3/4") Contains electronics; see electronics notice in the Buyer's Guide.

Estimate. £800 - 1,200



1423
Selena's (Faye Dunaway) Baphomet Statue + Supergirl (1984)

Selena's (Faye Dunaway) Baphomet statue from Jeannot Szwarc's superhero film Supergirl. Selena used her statue of Baphomet as a vessel for the Omegaedron, a powerful object which imbued Selena with powers. The statue is made of silver-painted fibreglass, and resembles a human-goat hybrid. The top section is removable, revealing an interior cavity. The statue has some paint wear, damage to the talons, and cracks in the horns. Dimensions: 56 cm x 46 cm x 42.5 cm (22" x 18" x 16 3/4")

Estimate. £3,000 - 5,000

1424
Large Kryptonian Console Crystal + Superman (1978)

A large Kryptonian console crystal from Richard Donner's superhero film Superman. Elaborate crystals formed the consoles seen within the Arctic Fortress of Solitude on the planet Krypton, the home of Superman (Christopher Reeve). The crystal shard is made of clear acrylic and features a multi-faceted finish. Intentional small cracks and scuffs have been applied to the surface to create a unique crystalline appearance when lit from below. There is a drill hole at the top where it was initially attached onset, and the lot comes presented on a custom Superman emblem shaped display base. Dimensions (displayed): 15 cm x 20 cm x 50 cm (6" x 8" x 19 1/2")

Estimate. £3,000 - 5,000

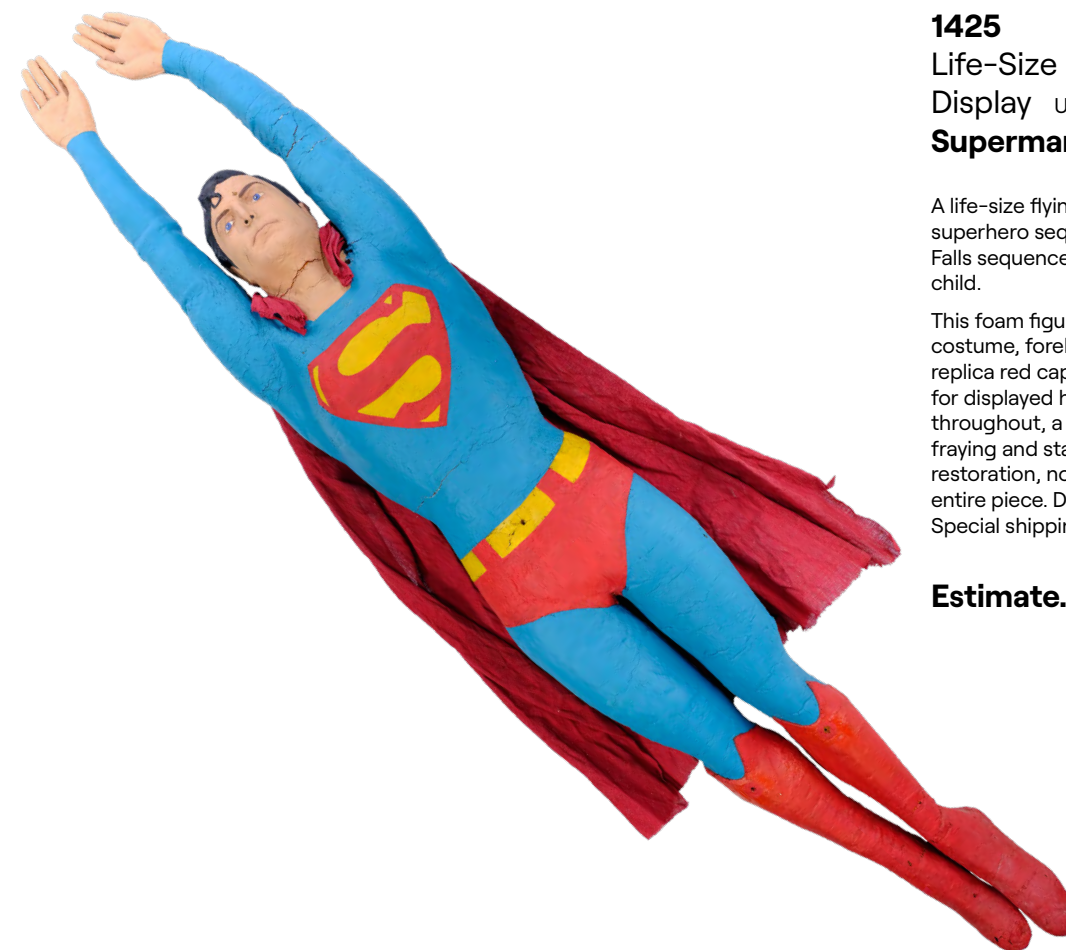

1425
Life-Size Flying Superman (Christopher Reeve) Display + Superman II (1980)

A life-size flying Superman (Christopher Reeve) from Richard Lester's superhero sequel Superman II. This figure was created for the Niagara Falls sequence, where Superman flew into the falls to catch a falling child.

This foam figure features detailed painting including Superman's iconic costume, forelock, and Reeve's blue eyes. Attached to the back is a replica red cape, added for display, with holes where a hook protrudes for displayed hanging. The foam exhibits stiffening and cracking throughout, a hole in the centre of the belt and in each knee, and fraying and staining to the cape. This figure has undergone extensive restoration, nose and finger replacement, and full repainting of the entire piece. Dimensions: 254 cm x 43.25 cm x 28 cm (100" x 17" x 11") Special shipping required; see notice in the Buyer's Guide.

Estimate. £3,000 - 5,000



1426
"I Spent the Night with Superman" Daily Planet Newspaper + Superman (1978)

An "I Spent the Night with Superman" Daily Planet newspaper from Richard Donner's superhero film Superman. Lois Lane (Margot Kidder) spent the evening with Superman, (Christopher Reeve) then wrote an article about her experience in the Daily Planet, which was read by Otis (Ned Beatty) and Eve (Valerie Perrine) in Lex Luthor's (Gene Hackman) lair. The newspaper features the headline "I Spent the Night with Superman" above a picture of Superman and the article. The cover page is wrapped around several pages of the International Herald Tribune. It has some discolouration and has been folded in half. Dimensions (folded): 31.5 cm x 43 cm (12 1/2" x 17")

Estimate. £2,000 - 3,000



1427
Daily Planet Newspaper and Cover Page + Superman (1978)

A "Lex Luthor's Scheme 'Bombs' Superman Saves Nation" Daily Planet newspaper and "Twin Nuclear Missiles Test Confirmed" cover page from Richard Donner's superhero film Superman. Otis (Ned Beatty) bought a newspaper with the headline "Twin Nuclear Missiles Test Confirmed" and showed it to Lex Luthor (Gene Hackman). This lot consists of a cover page with the "Nuclear Missile" headline, and a newspaper with the headline "Lex Luthor's Scheme 'Bombs' Superman Saves Nation". The newspapers have some discolouration and sun-bleaching. Dimensions (folded): 31.5 cm x 43 cm (12 1/2" x 17")

Estimate. £2,000 - 3,000

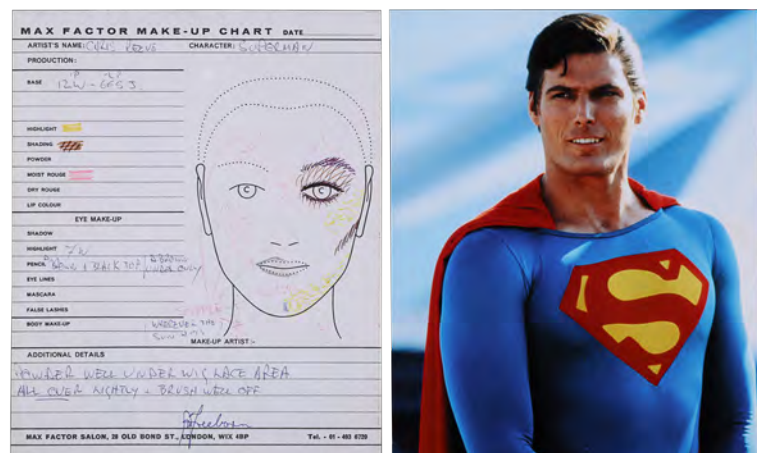

1428
 Superman (Christopher Reeve) Make-Up Chart +Δ
Superman (1978)

A Superman (Christopher Reeve) make-up chart from Richard Donner's superhero film Superman. This make-up chart was signed off by legendary make-up artist Stuart Freeborn and features handwritten notes on what make-up Reeve should have and where. It is undated and accompanied by a photo of Reeve as Superman. Dimensions: 25 cm x 20 cm (9 ¾" x 8")

Estimate. £400 - 600



1430
 Marlon Brando Rare Behind the Scenes Colour Photographs M
Superman (1978)

A collection of rare Marlon Brando behind the scenes photographs from Richard Donner's superhero film Superman. This lot consists of six colour photographs, printed on glossy photographic paper, depicting Marlon Brando as Jor-El behind the scenes and one sepia-toned polaroid of Brando partially in costume, seated on set. Some of these also feature Donner alongside Brando, directing the set-up for the scene. Dimensions: (each colour photo) 27.5 cm x 21.5 cm (10 ¾" x 8 ½") Sold without copyright; see copyright notice in the Buyer's Guide.

Estimate. £300 - 500



1429
 Two Oversized Storyboards M
Superman (1978)

Two oversized storyboards from Richard Donner's superhero film Superman. Each A2 page features a printed storyboard of a Metropolis street, with one showing Superman (Christopher Reeve) bursting out from underground, having escaped from Lex Luthor's (Gene Hackman) lair. The scene does not appear like this in the final cut of the film. One is labelled "240 - Dusk" and the other is labelled "240 - Dusk - Cut to Crowd Reaction". The pages have wear from age and use, including rips, staining and discolouration. Dimensions (each): 51 cm x 76 cm (20" x 30")

Estimate. £400 - 600



1431
 Christopher Reeve Autographed Photo M
Superman (1978)

A Christopher Reeve-autographed photo from the promotion of Richard Donner's Superman. The black-and-white image shows a close-up of Superman (Christopher Reeve) in his signature costume and is autographed along the bottom by Reeve in blue ink. "To Spencer" is also inscribed in black ink near the lower edge. Dimensions: 25.5 cm x 20.5 cm (10" x 8")

Estimate. £400 - 600



1432
 Margot Kidder-autographed Photo Inscribed to Dave Prowse M
Superman (1978)

A Margot Kidder-autographed photo inscribed to Dave Prowse from the production of Richard Donner's superhero film Superman. Actor and bodybuilder Prowse - who notably played Darth Vader in the original Star Wars trilogy - trained Christopher Reeve for the title role. The photo features Reeve and Kidder, and is inscribed in blue ink "For David, with love, Margot Kidder". The photo is in a protective plastic sleeve and accompanied by the original bill of sale from the Prowse estate. Dimensions: 20 cm x 25 cm (8" x 9 ¾")

Estimate. £200 - 300



1433
 Non (Jack O'Halloran) SFX Flying Model Miniature M
Superman II (1980)

A Non (Jack O'Halloran) SFX flying model miniature from Richard Lester's superhero sequel Superman II. Miniatures were used during the film for some shots of General Zod (Terence Stamp), Ursa (Sarah Douglas) and Non flying. Created by renowned visual effects supervisor Derek Meddings, this miniature is a cast resin model of Non with his arms stretched out in front of him, and it features a highly detailed painted face. There are small holes in the head and crotch, through which a filament was passed, and a larger hole is present in the torso's back where the model was affixed to a rig. Presented on a custom-built stand, the model displays several cracks with signs of sympathetic restoration around the neck and right hand, and its left hand is missing. Dimensions (displayed): 32 cm x 9 cm x 37 cm (12 ½" x 3 ½" x 14 ½")

Estimate. £3,000 - 5,000

1434
 Fortress of Solitude Crystal +Δ
Superman II (1980)

A Fortress of Solitude crystal from Richard Lester's superhero sequel Superman II. Clear crystals appeared in several sequences set in Superman's (Christopher Reeve) Arctic citadel, including Lex Luthor's (Gene Hackman) infiltration, Superman's transformation into a mortal, and his final confrontation with General Zod (Terence Stamp) and his Kryptonian cohorts. The Fortress of Solitude and several crystals also appeared in the first film of the franchise, Superman, with which this sequel was filmed back-to-back. Made of resin and displaying an angular, shard-like shape, the crystal exhibits light surface scratches. Dimensions: 29 cm x 3.5 cm x 2 cm (11 ½" x 1 ½" x ¾") Sold without copyright; see copyright notice in the Buyer's Guide.

Estimate. £3,000 - 5,000



1435
 Pair of Daily Planet "White House Surrenders" Newspapers M
Superman II (1980)

A pair of Daily Planet "White House Surrenders" newspapers from Richard Lester's superhero sequel Superman II. A newsstand across from the Daily Planet offices displayed news of the President's (E.G. Marshall) surrender to Kryptonian General Zod (Terence Stamp) as Superman (Christopher Reeve) arrived to challenge Zod to a fight. This lot consists of two black-and-white production-made newspaper covers jacketing an inner spread of a 1979 pre-existing copy of the Windsor Express newspaper. The covers feature the headline "White House Surrenders" along with photos of the President and General Zod. They exhibit staining down their left edges as well as minor discolouration and fold lines due to storage. Dimensions (each): 57.5 cm x 43.5 cm (22 3/4" x 17 1/4")

Estimate. £2,000 - 3,000



1436
 Four Daily Planet Newspapers M
Superman III (1984)

Four Daily Planet newspapers from Richard Lester's superhero sequel Superman III. These production-made newspapers refer to various plot points throughout the film, most notably the incident when Superman turns bad and starts causing trouble around the world, and when he finally defeats his darker self. This lot includes three black-and-white newspapers featuring the headlines "Danger-Superman at Work", "Badman at Work" and "Oils Well That Ends Well! Superman Super Again", along with images of Superman. Accompanying these is another newspaper comprising a Daily Planet cover glued to a spread from a 1979 copy of the Windsor Express. The headline reads "City Councillors Give Go Ahead to New Community Open Space" and inside is a second sheet from a 1979 Windsor Express. The lot displays minor discolouration and fold lines due to storage. Dimensions: 57.5 cm x 42.5 cm (22 3/4" x 16 3/4")

Estimate. £2,000 - 3,000



1437
 Pair of Newspapers Ω
Superman (1978)

A pair of newspapers from Richard Donner's superhero film Superman. After Superman's (Christopher Reeve) debut, various news sources published stories about the mysterious hero. In a deleted scene, visible in production contact sheets (not included), Lois Lane (Margot Kidder) doodled on a newspaper with a large photo of Superman on it, as she wondered about his secret identity. This lot consists of two newspapers, both printed in black-and-white on newsprint. One is a Daily News paper with the headline "Look Ma - No Wires!" and an image of Superman flying; the other one features the headline "Inside Story of Superman" with large close-up photographs of Superman. They exhibit discolouration, corner creasing, and mild tears. Dimensions (each): 59.75 cm x 45.75 cm (23.5" x 18")

Estimate. £1,500 - 2,500



1438
 "Superman Extinguishes Flames" Daily Planet Newspaper †Δ
Superman III (1983)

A Daily Planet "Superman Extinguishes Flames" newspaper from Richard Lester's superhero sequel Superman III. The production-made newspaper refers to the moment 'evil' Superman (Christopher Reeve) blew out the Olympic flame, but the sequence was ultimately not used in the final cut of the film. Consisting of the front and back cover, the piece is printed on newspaper stock with the Daily Planet logo at the top. A black-and-white image of Superman standing proudly features on the front, with various articles surrounding the photo and multiple advertisements adorning the back cover. The newspaper displays two small tears on the top edge. Dimensions: 57.5 cm x 42.5 cm (22 3/4" x 16 3/4")

Estimate. £600 - 800



1439
 Pair of Metropolis Car Licence Plates Ω
Superman Franchise (1978 - 1987)

Two Metropolis car licence plates from the productions of the Christopher Reeve-era Superman film series. Licence plates appeared throughout all four films on cars both overturned and undamaged in Metropolis. These plates, one without screw holes numbered "PED702" and one with screw holes numbered "KLT944," are constructed from aluminium with tape residue on their reverses from being applied to production vehicles. Both exhibit intentional distressing with bent aluminium, as well as grime and soot applied by production. Dimensions (each): 30.5 cm x 15.25 cm x 2.5 cm (12" x 6" x 1")

Estimate. £2,000 - 3,000



1441
 Gus Gorman's (Richard Pryor) Supercomputer Screw M
Superman III (1983)

Gus Gorman's (Richard Pryor) supercomputer screw from Richard Lester's superhero sequel. Gus unscrewed a vital part of the supercomputer and ate the screw, saving Superman's (Christopher Reeve) life. The metal screw features a red head covered in fabric. The lot is accompanied by a letter of authenticity detailing its history. Dimensions: 2 cm x 1 cm x 1 cm (3/4" x 1/2" x 1/2")

Estimate. £400 - 600



1440
 Derek Meddings-made Model Miniature Car †
Superman III (1984)

A Derek Meddings-made model miniature car from Richard Lester's superhero sequel Superman III. This miniature was made by the legendary special effects designer Meddings and his team for a section of the scene in which Evil Superman (Christopher Reeve) and Clark Kent (also Reeve) fought in a scrapyard. The shots involving the miniature were ultimately cut, but the full-scale car can be seen on the car crusher conveyor belt. The car is made of fibreglass and metal, with acrylic windows and it has been intentionally distressed. The car is accompanied by nine behind-the-scenes photos showing the sequence being filmed. Dimensions: 118 cm x 45 cm x 30 cm (46 1/2" x 17 3/4" x 11 3/4")

Estimate. £500 - 700



1442
 Set of Storyboards †Δ
Superman III (1983)

A set of 151 storyboards from the production of Richard Lester's superhero sequel Superman III. These storyboards illustrate the climactic fight sequence, from Superman's (Christopher Reeve) flight to Ross Webster's (Robert Vaughn) hideout - containing Gus Gorman's (Richard Pryor) supercomputer - to the moment the machine is destroyed. Each printed storyboard features the production title and page number along the top, with a brief description of what is happening in the relevant scene. Pages 62, 63, 64, and 120 are missing from the set, and there are some minor tears on the first page. Dimensions (each): 21 cm x 30 cm (8 1/4" x 11 3/4")

Estimate. £600 - 800



1443
 Superman's (Christopher Reeve) Photo Booth Strips with Opening Credit Sequence Storyboard File **M**
Superman III (1984)

Superman's (Christopher Reeve) photo booth strips with a storyboard sequence file from Richard Lester's adventure comedy Superman III. Photo strips were used during the opening sequence when Clark Kent changes into Superman by running into a photobooth with a child waiting outside; when Superman emerges, he realises that his image has been captured as he's changed and quickly tears off the pictures of Clark and hands the rest to the child. This lot comprises two photo strips made of semi-gloss photo paper featuring four photos each as Clark changes clothes, one has had the last picture (showing Superman) torn away from the rest. The storyboard sequence depicts the opening credit scenes as Superman comes to the rescue after a series of chaotic events ricochet across the city; the file consists of 106 pages of printed illustrations featuring descriptions of the events occurring. Dimensions: (Photo Strip) 20 cm x 4 cm (8" x 1½"), (File) 38 cm x 24 cm x 2 cm (15" x 9½" x ¾")

Estimate. £3,000 - 5,000



1444
 Hand-Drawn and Printed Jack Johnson Spacecraft Concept Art **Ω**
Superman Lives (Unproduced)

Hand-drawn and printed Jack Johnson spacecraft concept art from the production of Tim Burton's unproduced superhero adventure Superman Lives. This lot consists of 10 drawings rendered in mixed media (three on vellum, seven on tracing paper) and 13 printed copies of drawings on standard white paper. Nine of the drawings are signed by art department illustrator Johnson. It exhibits torn edges and creasing to the vellum pages and pinholes in the corners of all pages. Dimensions (largest): 48.5 cm x 62.25 cm (19" x 24.5"); (smallest): 21.75 cm x 28 cm (8.5" x 11") Sold without copyright; see notice in the Buyer's Guide.

Estimate. £400 - 600



1445
 Leviathan/Demon Tablet **Ω**
Supernatural (T.V. Series, 2005 - 2020)

A Leviathan/Demon tablet from the dark fantasy series Supernatural. In the Season 7 episode "Reading is Fundamental," Sam (Jared Padalecki) and Dean Winchester (Jensen Ackles) acquired a Leviathan tablet which only Kevin Tran (Osric Chau) could read. Tran later read how to close Hell on the Demon Tablet. This double-sided foam tablet originated with a crew member. It is carved to resemble stone with off-white detailing, and features otherworldly etchings on one side corresponding to leviathans and one side to demons. The tablet is intentionally distressed by production to appear ancient with scuffs and pitting in the foam from use. Dimensions: 23 cm x 21.75 cm x 3.25 cm (9" x 8.5" x 1.25")

Estimate. £2,500 - 3,500



1446
 Angel Dagger **Ω**
Supernatural (T.V. Series, 2005 - 2020)

A fate-killing blade from the dark fantasy series Supernatural. In the Season 6 episode "My Heart Will Go On," Balthazar (Sebastian Roche) tried to kill Atropos (Katie Walder) with his blade while she was distracted by Castiel (Misha Collins). This metal dagger originated with a crew member. It features a four-edged blade that tapers into a normal blade with a curved cut-out at the tip and brass-colour electroplating, as well as an etched handle and pommel painted black. The dagger exhibits chips and notable paint marks. Dimensions: 43.25 cm x 12 cm x 5.25 cm (17" x 4.5" x 2") Blade was dulled by production.

Estimate. £1,200 - 1,800



1447
 James Keziah Delaney's (Tom Hardy) Pistol **M**
Taboo (T.V. Series, 2017)

James Keziah Delaney's (Tom Hardy) pistol from the BBC TV drama Taboo. Delaney used his pistol to protect Lorna (Jessie Buckley) from kidnappers in the third episode and during the street fight against British soldiers in the season finale. This rubber firearm is based on a Sea Service Tower flintlock pistol. It is painted to resemble wood, with a silver-toned barrel and a brass-coloured trigger guard and butt cap. It features the inscriptions "Tower" and "GR" below the image of a crown on the lockplate. The pistol exhibits paint wear and a crack in the hammer from production use. Dimensions: 39 cm x 17 cm x 6 cm (15 ½" x 6 ¼" x 2 ½") Restricted ownership; see replica firearm notice in the Buyer's Guide.

Estimate. £2,000 - 3,000

1448
 Screen-matched Light-up Surveillance Droid **⊕**
Surrogates (2009)

A screen-matched light-up FBI surveillance droid from Jonathan Mostow's 2009 sci-fi action film Surrogates. The FBI used surveillance drones to monitor hundreds of video screens under the supervision of network administrator Bobby (Devin Ratray). It can be matched to the droid seen on screen through the serial number and several marks and imperfections on the back. The droid is made primarily of resin and plastic over a metal skeleton and frame. It stands on three moveable legs underneath a central circular support. The lights on the arm protruding from its chest illuminate when powered using a US-style mains plug, and long animatronics cables to control the head run from the chest. The drone has a serial number sticker on the back, and the decals on the shoulders and back read "362 G23". Dimensions: 78 cm x 78 cm x 118 cm (30 ¾" x 30 ¾" x 40 ½") Contains electronics; see electronics notice in the Buyer's Guide. Special shipping required; see special shipping notice in the Buyer's Guide.

Estimate. £3,000 - 5,000



1449
Comic-con Prop Ted Bear Ω
Ted 2 (2015)

An on-screen Ted toy from Seth MacFarlane's comedy sequel Ted 2. Ted (Seth MacFarlane) hid in a display of toy bears sharing his likeness while trying to flee his stalker Donny (Giovanni Ribisi) at the New York Comic-Con. The toy is made from tawny synthetic fur, with plastic eyes and nose. It is stuffed with hollow fibre filling and has stiff plastic pads on its feet to allow it to stand. It also features a working voice box hidden beneath a Velcro pouch in its back; the voice box has an on/off switch and is activated by a button in the toy's right hand, saying phrases such as "Hey Johnny, how 'bout a beer, huh?" and "Hehe, come here ya bastard!" Dimensions: 62 cm x 40 cm x 22 cm (24 1/2" x 16" x 8 3/4") Contains electronics; see electronics notice in the Buyer's Guide.

Estimate. £1,500 - 2,500

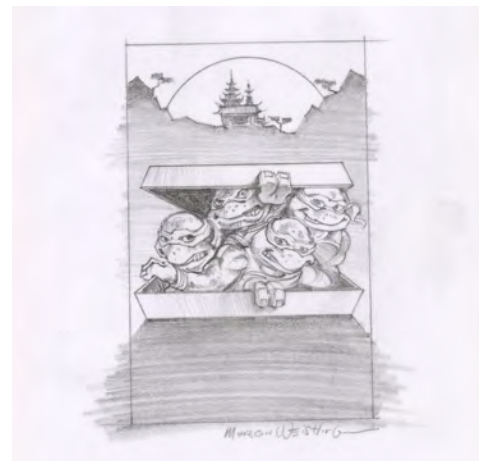

1450
Hand-drawn Morgan Weistling Poster Concept Design \mathcal{M}
Teenage Mutant Ninja Turtles III (1993)

A hand-drawn Morgan Weistling poster concept design for the promotion of Stuart Gillard's superhero sequel Teenage Mutant Ninja Turtles III. This illustration is a development sketch made during the early stages of the poster design process. Rendered in pencil on tracing paper and taped to a sheet of white paper, it depicts the four turtles emerging from a box in front of a horizon outlining a Japanese pagoda and trees against a giant sun. The drawing exhibits some pencil smudges and a yellow stain at the bottom of the tracing paper. Dimensions: 29.5 cm x 21 cm (11 1/2" x 8 1/4") Sold without copyright; see copyright notice in the Buyer's Guide.

Estimate. £400 - 600



1451
JB's (Jack Black)
Sasquatch Costume Ω
Tenacious D In The Pick Of Destiny (2006)

JB's (Jack Black) Sasquatch costume from Liam Lynch's musical comedy Tenacious D in The Pick of Destiny. JB ate wild mushrooms and hallucinated about being a baby Sasquatch with his father Sasquatch (John C. Reilly). This costume consists of a full body jumpsuit applied throughout with synthetic brown fur; a detachable, open-faced cowl with snap button closures; a pair of hand-painted urethane gloves; and large, matching urethane feet with rubber and foam padding. The costume exhibits some hair shedding, and the hands and feet exhibit grime stains and tearing from wear.

Estimate. £2,000 - 3,000



1452
T-800 Climbing Ladder Hand-drawn Storyboard $\mathcal{+}\Delta$
Terminator, The (1984)

A hand-drawn storyboard from the production of James Cameron's sci-fi action film The Terminator. The artwork depicts a close-up of the T-800's (Arnold Schwarzenegger) head entering the frame as it climbs a ladder within the factory during the film's climactic sequence. Rendered in a combination of pencil and charcoal on tracing paper, this storyboard is labelled "91" in red-coloured marker and features an upwards arrow directing the action as it would appear in shot. There is a red ink mark on the right edge and signs of smudging. Dimensions: 21 cm x 27.5 cm (8 1/4" x 10 3/4") Sold without copyright; see copyright notice in the Buyer's Guide.

Estimate. £1,500 - 2,500

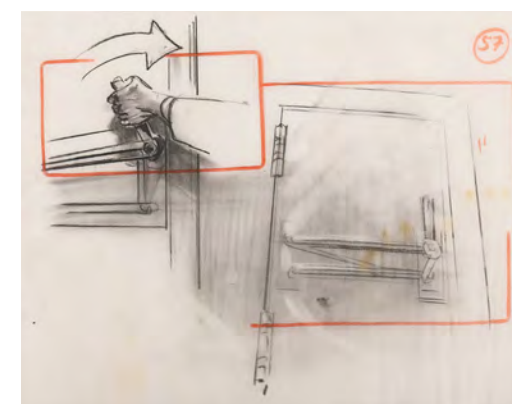
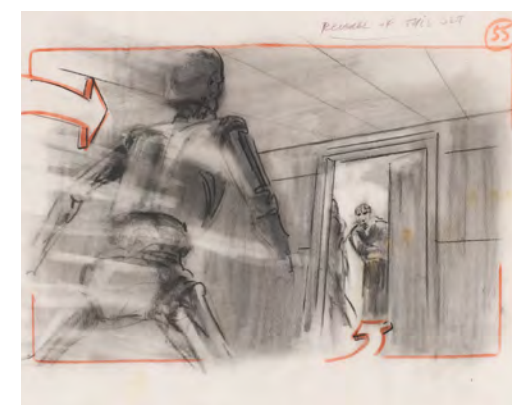

1453
Locked Door Sequence Hand-drawn Storyboards $\mathcal{+}\Delta$
Terminator, The (1984)

A set of two hand-drawn storyboards from the production of James Cameron's sci-fi action film The Terminator. The lot consists of two pages showing the moment Sarah Connor (Linda Hamilton) and Kyle Reese (Michael Biehn) locked a door to temporarily prevent the T-800 (Arnold Schwarzenegger) from entering the factory. The artwork is rendered in pencil and charcoal on tracing paper, with red-coloured marker used to frame each drawing and directional arrows. Both sheets have been labelled "55" and "57", respectively, and one displays an annotation reading "Reverse of this set". The set displays minor signs of smudging and marks. Dimensions (each sheet): 21 cm x 27.5 cm (8 1/4" x 10 3/4") Sold without copyright; see copyright notice in the Buyer's Guide.

Estimate. £1,500 - 2,500



1454
Set of Two Factory Sequence Hand-drawn Storyboards $\mathcal{+}\Delta$
Terminator, The (1984)

Two hand-drawn storyboards from the production of James Cameron's sci-fi action film The Terminator. The lot consists of two pages featuring four storyboards depicting moments from the sequence where Sarah Connor (Linda Hamilton) and Kyle Reese (Michael Biehn) retreated into the factory whilst being pursued by the T-800 (Arnold Schwarzenegger). The artwork is rendered in graphite pencil and charcoal on tracing paper, with white-coloured pencil applied onto one sketch. Both sheets have been labelled "36" and "64", respectively, in red marker. One page displays a brief scene description reading, "Sarah's hand reaches in ... - Opens the door", and both sheets show directional arrows. Dimensions (larger sheet): 21 cm x 27.5 cm (8 1/4" x 10 3/4") Sold without copyright; see copyright notice in the Buyer's Guide.

Estimate. £1,500 - 2,500



1455
The Terminator's (Arnold Schwarzenegger) T-Shirt \mathcal{M}
Terminator 2: Judgment Day (1991)

The Terminator's (Arnold Schwarzenegger) T-shirt from James Cameron's sci-fi action sequel Terminator 2: Judgment Day. The Terminator acquired a T-shirt and new outfit from a biker at the beginning of the film. This version of the T-shirt displays no sign of distressing, suggesting it was worn from the point the Terminator acquired the garment to the moment he was shot in the Galleria shopping mall, while protecting John Connor (Edward Furlong) from the T-1000 (Robert Patrick). Marked size "XL 46-48", this black cotton Hanes® T-shirt was originally acquired directly from one of the film's production companies. The garment displays some minor holes and tape remnants from being previously displayed. The lot is accompanied by a letter from a previous owner detailing its history.

Estimate. £3,000 - 5,000

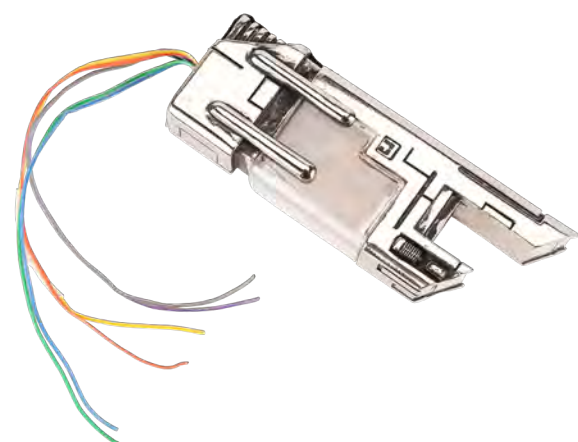

1456
T-850 Hydrogen Fuel Cell †Δ
Terminator 3: Rise Of The Machines (2003)

A T-800 endoskeleton fuel cell from Jonathan Mostow's sci-fi action sequel Terminator 3: Rise of the Machines. The Terminator (Arnold Schwarzenegger) used its last remaining fuel cell to sacrifice itself and destroy the T-X (Kristanna Loken). The cell is made of chrome-plated resin, with a translucent plastic section at the centre and colourful wires protruding from one end. The cell has been intentionally distressed to look well worn. It has some glue remnants at the wired end and a section of black tape down one side. Dimensions: 11.5 cm x 3 cm x 4 cm (4 1/2" x 1 1/4" x 1 1/2")

Estimate. £1,500 - 2,500



1458
Miniature Barrel and Bucket M
Thing, The (1982)

A miniature barrel and bucket from John Carpenter's sci-fi horror The Thing. Various barrels and buckets were seen around the Antarctic research base and miniatures were used during the climactic scene of MacReady (Kurt Russell) facing off against the Thing and using explosives to destroy it. The barrel is made of a card tube with a resin shell and lid, and the smaller bucket is made of resin. Both have been intentionally distressed. The barrel has part of its lip missing at the top, and the bucket no longer has a handle. Dimensions (barrel) 18.5 cm x 13 cm x 13 cm (7 1/4" x 5" x 5")

Estimate. £1,000 - 1,500



1457
Two Hand-drawn Pencil Storyboards of Mac and the Puddles †Δ
Thing, The (1982)

A pair of hand-drawn pencil storyboards from John Carpenter's sci-fi horror The Thing. The storyboards show the scene in which MacReady (Kurt Russell) and Dr Copper (Richard Dysart) explored the ruins of the Norwegian camp. The storyboards are rendered in pencil with a description of the shot written underneath and are signed "Ploog". Comic book artist Mike Ploog worked as a production illustrator on the film and later worked on The Dark Crystal, Ghostbusters, and X-Men. The pages are hole-punched and have some minor edgewear and additional pencil markings. Dimensions (each): 21.5 cm x 28 cm (8.5" x 11") Sold without copyright; see copyright notice in the Buyer's Guide.

Estimate. £600 - 800

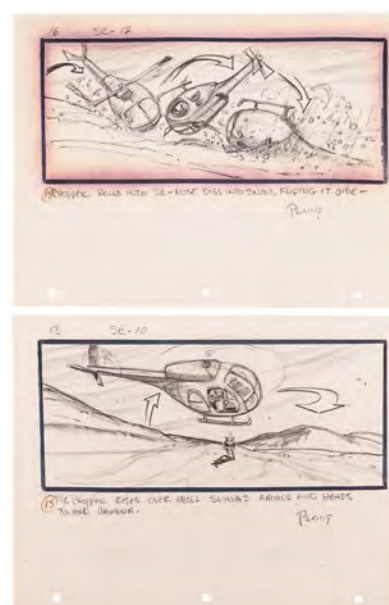

1459
Two Hand-drawn Pencil Storyboards of the Crashing Helicopter †Δ
Thing, The (1982)

A pair of hand-drawn pencil storyboards from John Carpenter's sci-fi horror The Thing. The storyboards show the Norwegian helicopter crashing as it chases the dog in the opening scenes. In the final cut, the scene ends with the helicopter exploding from a grenade, not crashing. The storyboards are rendered in pencil with a description of the shot written underneath and are signed "Ploog". Comic book artist Mike Ploog worked as a production illustrator on the film and later worked on The Dark Crystal, Ghostbusters, and X-Men. The pages are hole-punched and have some minor edgewear and additional pencil markings. Dimensions (each): 21.5 cm x 28 cm (8.5" x 11") Sold without copyright; see copyright notice in the Buyer's Guide.

Estimate. £600 - 800

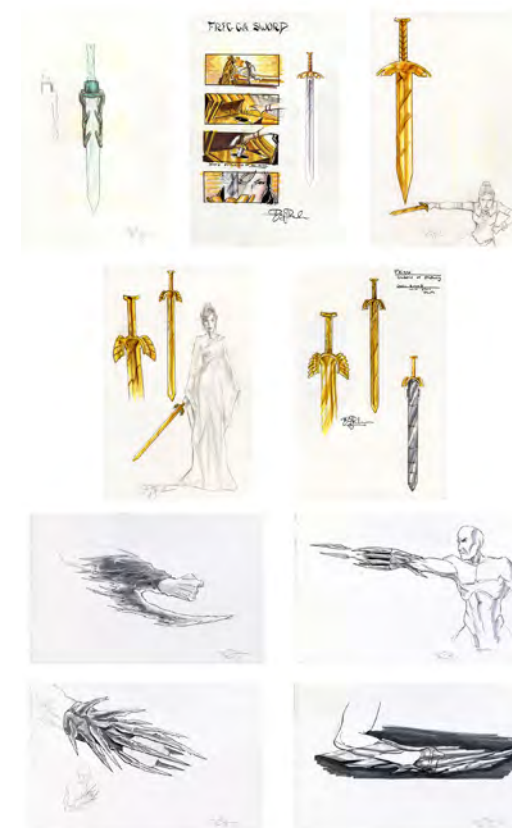

1460
Set of Nine Hand-Illustrated Doug Brode Frost Giant and Sword Concept Artworks Ω
Thor (2011)

Nine Frost Giant and sword concept artworks hand-illustrated by conceptual artist Doug Brode for Kenneth Branagh's superhero adventure Thor. The Asgardians wielded a variety of weapons, including swords, against the Frost Giants unleashed by Loki (Tom Hiddleston) during the Battle of Jotunheim. This set consists of nine concept artworks - four depicting the Giants' weaponized ice hands, four depicting Frigga's sword, and one depicting another otherworldly sword - rendered in mixed media on collaged paper and signed by Brode. The artworks exhibit creasing, flattened corners, and some staining. Dimensions (each): 28 cm x 43.25 cm (11" x 17") Sold without copyright; see notice in Buyer's Guide.

Estimate. £800 - 1,200



1461
Peter Nelson Collection: Replica Parker and Lady Penelope Puppets M
Thunderbirds (T.V. Series, 1965 - 1966)

Replica Parker and Lady Penelope puppets created after the production of Gerry and Sylvia Anderson's puppet animation television series Thunderbirds. Created by model-maker Martin J. Bower, known for his work on Outland, Flash Gordon and Alien, these high quality puppets are predominantly made from resin; the heads, hands and feet are painted with skin tones and faux-hair has been glued to the tops of the heads, eyelashes and - in Parker's case - eyebrows. The puppets feature their own outfits that include Parker's hat and Penelope's feather boa, they have moveable eyes and bottom lips and loose joints allowing them to be posed and puppeted. Bower's attention to detail has even added production-accurate touches such as a the label "Parker 2 Stage 1" hand-painted on his chest. Dimensions: (Each) 57 cm x 15 cm x 9 cm (22 1/2" x 6" x 3 1/2")

Estimate. £2,000 - 3,000



48 cm" (19")



180 cm" (71")

1462
FAB 1 Production Prototype Model †Δ
Thunderbirds (2004)

A FAB 1 production prototype model from Jonathan Frakes live action adaptation of Thunderbirds. This conceptual design of Lady Penelope's (Sophia Myles) famous car was made by the art department during the production of the movie, although the eventual design of the car was slightly different. The large maquette is made from wood with fibreglass detailing and has a hollow interior. It is painted in Lady Penelope's favourite shade of pink, with a black roof and silver and black-coloured wheels. Dimensions: 180 cm x 48 cm x 40 cm (71" x 19" x 15 3/4") Special shipping required: see special shipping notice in the Buyer's Guide.

Estimate. £2,000 - 3,000



1463
Life Vest Ω
Titanic (1997)

A life vest from James Cameron's romantic disaster film Titanic. Passengers made use of their life vests throughout the film's iconic sinking sequences as they struggled to evacuate the doomed vessel. This vest is constructed from cream-colour canvas with foam padding stitched into the front and back and matching wrap-around nylon straps on each side. Also included is a 20th Century Fox Certificate of Authenticity. The vest is speckled with grime and exhibits stains throughout from production wear.

Estimate. £2,500 - 3,500



1464
Jack's (Leonardo DiCaprio) Mirror Image Third-Class Ticket M
Titanic (1997)

Jack Dawson's (Leonardo DiCaprio) mirror image third-class ticket from James Cameron's romantic disaster film Titanic. Jack won his third-class passenger ticket in a poker game from Sven Gunderson (Dan Pettersson), whose passenger name is filled in at the bottom. To accurately show the Titanic's departure from Southampton on the port side, Cameron needed to film the starboard side and reverse the image in post-production. Therefore, this ticket, as well as many of the ship's signs and notices, had to be printed as a mirror image. The ticket is mounted in a framed display, which features the film's title printed on a brass plaque. Accompanying it is a 20th Century Fox certificate of authenticity, which notes that the ticket was "Won by Jack in on-shore gambling scene". Dimensions: 29 cm x 26 cm x 1.5 cm (11 1/2" x 10 1/4" x 1/2")

Estimate. £1,500 - 2,500



1465
Titanic Porthole Ω
Titanic (1997)

A Titanic porthole from James Cameron's romantic disaster film Titanic. Portholes were visible on the RMS Titanic throughout its doomed journey in the North Atlantic. Created for the full-size ship sets, this fibreglass porthole is hand-painted in two grey tones and mounted with a clear acrylic window. The fibreglass and paint exhibit chipping and cracking throughout from age and production use, and the metal screws exhibit rust stains. Dimensions: 33 cm x 33 cm x 4 cm (13" x 13" x 1.5")

Estimate. £300 - 500



1466
Lara Croft's (Alicia Vikander) Costume M
Tomb Raider (2018)

Lara Croft's (Alicia Vikander) costume from Roar Uthaug's action-adventure Tomb Raider. Lara wore her costume whilst travelling the island of Yamatai in search of her father and the cursed tomb of Himiko. Her costume became increasingly distressed throughout her adventure. The intentionally distressed stains on the top and the hole in the left leg of the trousers indicate that this version was used whilst she was captured by Mathias Vogel. This costume consists of a grey-green tank top, a pair of green cargo trousers and a brown leather belt featuring a gold-tone circular metal buckle that reads "The Boys Brigade" with a cross and anchor emblem in the centre. The trousers display the label "Heidi with Harness, Stage 2" handwritten in black pen on the underside of the interior back pocket. This indicates that the trousers were worn by a stunt performer during one of Croft's many death defying leaps that required a harness for shooting.

Estimate. £2,000 - 3,000



1468
"Immortals" US Deputy Marshal Badge Ω
Tombstone (1993)

An "Immortals" U.S. Deputy Marshal badge from George P. Cosmatos' Western Tombstone. Wyatt Earp's (Kurt Russell) posse of deputies, the Immortals, wore matching badges while riding Tombstone of the Cowboys. This lightweight metal badge is one of only 10 made for the film by Caravan West. It is engraved "US Deputy Marshal" with three star patterns. Also included are a colour-printed, behind-the-scenes photograph featuring Caravan West owner and costar Peter Sherayko along with a Letter of Authenticity from Sherayko. The badge exhibits scratching throughout from production use. Dimensions: 5 cm x 5 cm x 1.5 cm (2" x 2" x 0.5")

Estimate. £800 - 1,200



1467
Joseph A. Porro Hand-drawn Doc Holliday (Val Kilmer) and Morgan Earp (Bill Paxton) Costume Designs M
Tombstone (1993)

A pair of Joseph A. Porro costume designs from George P. Cosmatos' Western Tombstone. Doc Holliday (Val Kilmer) and Morgan Earp (Bill Paxton) fought alongside Wyatt Earp (Kurt Russell) during the gunfight at the O.K. Corral. Costume designer Porro worked with sketch artist Janet Schriever to create the two designs, for the costumes of Doc Holliday and Morgan Earp, respectively. Each is rendered in pencil and watercolour paint on card, and features the film and character names, along with Porro and Schriever's names, handwritten in pencil. Both pages have several lengths of tape on the reverse. Dimensions (each page): 43 cm x 35.5 cm (17" x 14") Sold without copyright; see copyright notice in the Buyer's Guide.

Estimate. £1,500 - 2,500



1469
Cmdr. Phillips' White Graduation Suit M
Top Gun (1986)

Cmdr. Phillips' white graduation suit from Tony Scott's action drama Top Gun. At the graduation ceremony, all the graduating naval aviators and their instructors were dressed in their formal service dress. This white naval uniform, known as service dress white, consists of a jacket (labelled size "M 46"), a pair of trousers (labelled size "37-R") and a combination hat (labelled size "7 1/2"). The jacket features a standing collar, shoulder boards, uniform ribbons, and a gold-toned naval aviator badge. There is a label stapled to the left cuff which reads "Monty Jordan, Jester" handwritten in pencil, and a label fastened to the inner lapel which has "Kimbor" handwritten in black pen. The labelling indicates that this costume may have been used for more than one character, including Cmdr. Phillips (Monty Jordan), and Jester (Michael Ironside). The combination hat features a yellow embroidered leaf motif on the peak, indicating a captain or commanding officer wore it, but is missing its gold strap and Naval Officer's Insignia. Handwritten in blue pen on the interior of the hat is "Monty Jordan Stunt Masters". This lot exhibits staining and a small tear in the lining of the jacket from production use.

Estimate. £2,000 - 3,000



1470
Wolfman (Barry Tubb) and Merlin's (Tim Robbins) Flight Trousers M
Top Gun (1986)

Wolfman (Barry Tubb) and Merlin's (Tim Robbins) flight trousers from Tony Scott's action drama Top Gun. Wolfman and Merlin wore their flight trousers during test flights and the final mission. This lot comprises two pairs of green anti-g flight trousers made by Flight Suits Ltd. Each pair features a thick waist section; cutaways at the crotch and knees; Velcro patches; a black leather shroud knife pocket; and an inflation hose. One pair is a size "Medium Regular", with the name "Wolfman" handwritten in black pen on its interior label; the other pair is a size "Large Regular", and displays the name "Merlin", also handwritten in black pen on its interior label. Both pairs exhibit discolouration, loose threads, and wear to the tape and rubber covers on the inflation hoses due to production use and age.

Estimate. £2,000 - 3,000



1471
Set of Four Costume Continuity Polaroids M
Top Gun (1986)

A set of four costume continuity polaroid photographs from Tony Scott's Top Gun. Two photographs feature Pete "Maverick" Mitchell (Tom Cruise): one wearing a US Navy summer khaki uniform with Ray-Ban sunglasses and the other wearing blue jeans and a dark blue shirt over a white T-shirt. The other two photographs feature Charlotte Blackwood (Kelly McGillis): one wearing a beige pencil skirt with a yellow short sleeve top and the other wearing blue jeans, brown leather cowboy boots and a yellow long sleeve top. Dimensions (each): 11 cm x 9 cm (4 1/4" x 3 1/2") Sold without copyright; see copyright notice in the Buyer's Guide.

Estimate. £1,000 - 1,500



1472
Tommy Tank and Searchlight Ω
Toys (1992)

A Tommy Tank and searchlight from Barry Levinson's 1992 comedy Toys. Lieutenant General Leland Zevo (Michael Gambon) created Tommy Tanks as instruments of war and used them against Leslie Zevo (Robin Williams). This lot consists of a resin tank and vehicle with a searchlight on top. The tank features a turret depicting a toy-like face with a helmet. The metal searchlight has electronic components. This tank and searchlight exhibit scuffing along the body and tire treads, and leaked oil. Dimensions (tank): 53.5 cm x 30.5 cm x 30.5 cm (21" x 12" x 12"); (searchlight): 56 cm x 24.25 cm x 30.5 cm (22" x 9.5" x 12") Contains electronics; see electronics notice in the Buyer's Guide.

Estimate. £3,000 - 5,000



1473
Woody Helmet and Control Box Ω
Toys (1992)

A light-up woody helmet and control box from Barry Levinson's 1992 comedy Toys. Alsatia Zevo (Joan Cusack) tested Leslie Zevo's (Robin Williams) prototype woody helmet, and later tested it with Gwen Tyler (Robin Wright). This clear acrylic helmet has numerous wires designed to illuminate it when connected to power and a plastic black cap shaped like a brain. The aluminium control box features a switch and three knobs: "YES," "GLOW," and "CHASE." Both exhibit scratching and discolouration. Dimensions (helmet): 23 cm x 23 cm x 12.75 cm (9" x 9" x 5"); (box): 28 cm x 20.5 cm x 15.25 cm (11" x 8" x 6") Contains electronics; see electronics notice in the Buyer's Guide.

Estimate. £2,000 - 3,000



1475
Bumblebee Licence Plate M
Transformers: Revenge Of The Fallen (2009)

A Bumblebee licence plate from Michael Bay's sci-fi action sequel Transformers: Revenge of the Fallen. Autobot scout Bumblebee was Sam Witwicky's (Shia LaBeouf) guardian and mode of transportation. This plastic plate is painted black and silver and reads "900 STRA" in raised lettering. It is accompanied by a letter of authenticity signed by Michael Bay. Dimensions: 15.5 cm x 30.5 cm x 0.5 cm (6 1/4" x 12" x 1/4")

Estimate. £2,000 - 3,000



1474
Battle Damaged "Tommy Tank" Zevo Toy M
Toys (1992)

A battle damaged "Tommy Tank" Zevo toy from Barry Levinson's fantastical comedy Toys. General Leland Zevo (Michael Gambon) sent several lethal miniature war toys, including "Tommy Tanks", to try and kill Leslie Zevo (Robin Williams) and his family. A vicious battle ensued between the original Zevo toys and Leland's newer war machines. This tank is made predominantly of fibreglass painted in grey chrome with red decals. Made to move on plastic caterpillar tracks, it also features two rotating guns and a frosted Perspex viewfinder that's fixed in an upright position. The top of the tank is fitted with a skeletal face in a German World War II-style helmet. The eyes, nose and mouth comprise LEDs, which lit up blue and white in the film. This tank exhibits intentional battle damage and wear from production use and age, including two missing missiles, repair tape, missing lenses over the LED eyes, a broken barrel on the front left gun, and other minor nicks to the paintwork. Dimensions: 52.5 cm x 28.5 cm x 32.5 cm (20 3/4" x 11 1/4" x 12 3/4") Contains electronics; see electronics notice in the Buyer's Guide. Contains mechanical components; see mechanical notice in the Buyer's Guide.

Estimate. £2,000 - 3,000



1476
Black Guard's Lightcycle Baton Ω
Tron Legacy (2010)

Black Guard's lightcycle baton from Joseph Kosinski's sci-fi action sequel Tron Legacy. Dictatorial program Clu (Jeff Bridges) and his team of elite warriors used their batons to deploy lightcycles as they battled fellow programs on the game grid. This black matte plastic baton features grey accents on the sides and centre. One side of the baton features a slanted edge where it could be inserted into the wearer's holster. It exhibits scuffing throughout and paint chipping on the side. Dimensions: 30.5 cm x 5.25 cm x 2.75 cm (12" x 2" x 1")

Estimate. £1,200 - 1,800



1477
Tugg Speedman's (Ben Stiller)
Distressed Costume M
Tropic Thunder (2008)

Tugg Speedman's (Ben Stiller) distressed costume from Stiller's comedy action film *Tropic Thunder*. Tugg's clothes became distressed after he became separated from the group, his sanity soon began to slip after he killed a panda and was captured by the heroin-producing gang The Flaming Dragons. The costume consists of a green cotton vest, a pair of green cotton military trousers, a strip of brown leather used as a headband and two production wardrobe tags detailing scene reference and costume details. The costume has been heavily distressed by the production with rips and stage blood.

Estimate. £1,000 - 1,500



1478
Eudorus' (Vincent Regan)
Breastplate and Myrmidon
Costume M
Troy (2004)

Eudorus' (Vincent Regan) breastplate and Myrmidon costume from Wolfgang Petersen's historical epic *Troy*. Eudorus wore his costume throughout the film, during its many battles. As Achilles' (Brad Pitt) second-in-command, Eudorus fought by his side, while storming the beach of Troy and sacking Apollo's temple. The breastplate is made of black woven leather, and features leather tassels, metal studs, leather lacing at the shoulders, and a strip of tape on the inside that displays "Eudorus #2" handwritten in black pen. Accompanying the breastplate is a black rubber Myrmidon helmet, a pair of laced leather-and-rubber greaves, and a pair of bracers. The helmet and the bracers both feature interior foam padding. The costume has been intentionally distressed, with fake blood applied, to make it appear aged and battle-worn. It also exhibits some additional wear from production use, including rust on the metal stud detailing and erosion of the foam inside the helmet.

Estimate. £2,500 - 3,500



1479
Triopas' (Julian Glover) Hero Armour M
Troy (2004)

Triopas' (Julian Glover) hero armour from Wolfgang Petersen's historical epic *Troy*. Triopas, the King of Thessaly, wore his armour as Achilles (Brad Pitt) defeated his champion Boagrius (Nathan Jones) in single combat. The armour is predominantly made of leather, with metal plating over the shoulders, around the neckline, and on the middle of the chest and back, as well as on sections of the belt, which fastens at the rear. "Triopas" is handwritten on two labels inside. The armour has been intentionally distressed to appear well worn. Some of the metal detailing is rusted in places and displays verdigris.

Estimate. £1,000 - 1,500



1480
Ajax's (Tyler Mane)
Armour M
Troy (2004)

Ajax's (Tyler Mane) armour from Wolfgang Petersen's historical epic *Troy*. Ajax wore his armour as he fought alongside Achilles (Brad Pitt) and the Greeks to assault the city of Troy. The armour features thick leather pieces with stitched detailing, as well as metal detailing down the side. It laces up at the back, and is marked "Ajax #1" in black ink on the interior. The armour has been intentionally distressed to appear well worn. Some of the metal detailing is a little rusted in places.

Estimate. £1,000 - 1,500



1482
Paris' (Orlando Bloom)
Tunic M
Troy (2004)

Paris' (Orlando Bloom) tunic from Wolfgang Petersen's mythical epic *Troy*. Paris wore his tunic under his armour throughout the film. The tunic is made from a navy blue, fleece-like material, with a golden zig-zag pattern. The sleeves feature circular metal studs and resin adornments painted to look like metal, and the sides of the tunic are tied with strips of fabric. The garment features a handwritten label reading "Orlando Bloom 3". One sleeve is missing a stud and the studs have some minor rusting.

Estimate. £600 - 800



1481
Menelaus' (Brendan Gleeson)
Armour M
Troy (2004)

Menelaus' (Brendan Gleeson) armour from Wolfgang Petersen's historical epic *Troy*. Spartan king Menelaus wore his armour in several scenes, notably when he fought Paris (Orlando Bloom), the lover of his wife Helen (Diane Kruger), outside the walls of Troy. The chest armour is made of dense brown rubber with a textured appearance, leather accents and wide straps. A strip of tape marked "Menelaus" is adhered to the armour's brown suede lining, and the sides of the garment are laced with brown leather thongs. The lot has been intentionally distressed to appear well worn, with small patches of green paint applied to create the appearance of a verdigris patina. A small round metal component is missing from both shoulders.

Estimate. £1,000 - 1,500



1483
Myrmidon Stunt
Costume M
Troy (2004)

A Myrmidon stunt costume from Wolfgang Petersen's historical epic *Troy*. Under the command of Achilles (Brad Pitt), Myrmidon soldiers wore their armour throughout the film, including the beach landing sequence, when they slaughtered Trojan soldiers to establish the Greek beachhead. The costume comprises a crested black rubber helmet featuring broad cheek plates and internal foam padding (labelled "Stunts, S7 27"); a set of woven leather body armour decorated, with brass studs and attached layered shoulder sections (labelled "Stunts" with other faded writing); a pair of leather bracers; and a pair of leather greaves. Metal panelling adorns the bracers and greaves. The metal components on the armour exhibit signs of corrosion from exposure to water during filming.

Estimate. £2,000 - 3,000

1484
Glaucus' (James Cosmo) Costume M
Troy (2004)

Glaucus' (James Cosmo) costume from Wolfgang Petersen's historical epic Troy. General Glaucus wore his armour in multiple scenes as he served King Priam (Peter O'Toole), and while making a speech to his army as they attempted to defend the city of Troy against the Greek forces. Made from rubber finished in gold-coloured paint, the costume comprises a helmet (labelled "Glaucus"); a chest plate with ornate panels and black-coloured gem-like detailing unique to this character (labelled "Glaucus #1"); and a pair of bracers (both labelled "Glaucus R"). The costume has been intentionally distressed to appear battle-worn, and there is an intentional split on the back of the helmet.



Estimate.
£1,500 - 2,500

1486
Lysander's (Owain Yeoman) Costume M
Troy (2004)

Lysander's (Owain Yeoman) costume from Wolfgang Petersen's historical epic Troy. Trojan General Lysander wore his armour in multiple scenes, most notably when Hector (Eric Bana) enquired how long before their army would be ready for the arrival of the Greeks. Lysander was last seen standing beside Helen (Diane Kruger) as Hector walked out the gates to meet Achilles (Brad Pitt). Made from rubber finished in gold-coloured paint, the costume comprises a helmet with foam padding inside; a breastplate with ornate panels and brown lacing at the sides; a pair of greaves; a pair of bicep bands; and a pair of bracers. All the items listed feature a suede lining and are labelled "Lysander". The costume has been intentionally distressed to appear aged and battle-worn.



Estimate.
£1,000 - 1,500

1485
Tecton (Mark Lewis Jones) Costume M
Troy (2004)

Tecton's (Mark Lewis Jones) costume from Wolfgang Petersen's historical epic Troy. Tecton was the commander of the Apollonian Guard and was notably seen telling Hector (Eric Bana) that his men were ready at the city gates before Achilles' (Brad Pitt) storming of the Trojan beaches. Made from vinyl finished in gold-coloured paint, the costume comprises a helmet featuring an attached brown-coloured long plume (labelled "Tecton"); a chest plate with ornate panels and patterns unique to this character (labelled "Tecton"); a pair of bracers (both labelled "Tecton Double"); and a pair of greaves (one labelled "Tecton Double"). The costume has been intentionally distressed to appear well worn.



Estimate.
£1,000 - 1,500

1487
Agamemnon's (Brian Cox) Stunt Sword M
Troy (2004)

Agamemnon's (Brian Cox) stunt sword from Wolfgang Petersen's historical epic Troy. The King of Mycenae wielded his sword throughout the film, most notably when he led the attack on the city of Troy. The sword is made of dense rubber with a metal armature, and the blade features an intricate swirling pattern running along its length. The handle of the weapon comprises a curved guard, a cross-patterned hilt and a circular pommel, all finished in red paint. Green paint replicating verdigris has been applied along the blade, and there are patches of wear to the paint finish. Dimensions: 67 cm x 9 cm x 7 cm (26 1/4" x 3 1/2" x 2 3/4")



Estimate.
£2,000 - 3,000

1488
Boagrius' (Nathan Jones) Sword M
Troy (2004)

Boagrius' (Nathan Jones) sword from Wolfgang Petersen's historical epic Troy. King Triopas' (Julian Glover) champion Boagrius wielded his sword during his duel with Achilles (Brad Pitt), who swiftly defeated him. The heavyweight sword comprises a solid bronze blade that has an intentionally weathered appearance, and a black-painted rubber grip decorated with faded, silver-coloured stripes. A flower emblem adorns the underside of the sword's circular pommel. Paint marks are present at the top of the grip. Dimensions: 81 cm x 7.5 cm x 8 cm (31 3/4" x 3" x 3 1/4")



Estimate.
£2,000 - 3,000

1490
Hero Myrmidon Sword M
Troy (2004)

A hero Myrmidon sword from Wolfgang Petersen's historical epic Troy. The Myrmidons, commanded by Achilles (Brad Pitt), used their swords in battle throughout the film. The sword is cast in bronze, with parallel grooves running along the blade and a detailed resin grip, finished in brown, attached to either side of the handle. The blade features some nicks and scratches along the edge from production use. Dimensions: 69 cm x 16 cm x 4 cm (27 1/4" x 6 1/4" x 1 1/2")



Estimate. £1,000 - 1,500

1489
Hector's (Eric Bana) Carving Knife, Agamemnon's (Brian Cox) Dagger and Briseis' (Rose Byrne) Knife M
Troy (2004)

Hector's (Eric Bana) carving knife, Agamemnon's (Brian Cox) dagger and Briseis' (Rose Byrne) knife from Wolfgang Petersen's historical epic Troy. Hector used his knife to carve wooden animals, Agamemnon stabbed his dagger into a map while strategising, and Briseis held her knife up to Achilles' (Brad Pitt) throat while she was his prisoner. All three are made of cast bronze, and Hector's knife has faux leather wrapped around the handle. Dimensions (Agamemnon's dagger): 42 cm x 7.5 cm x 3 cm (16 1/2" x 3" x 1 1/4")



Estimate.
£1,500 - 2,500



1491
Martin Asbury Hand-drawn Pencil Storyboards for Helen of Troy at the Palace M
Troy (2004)

A collection of hand-drawn storyboards from Wolfgang Petersen's historical epic Troy, by credited storyboard artist Martin Asbury. This collection consists of 13 pencil storyboards for various scenes, including Hector (Eric Bana) convincing Helen (Diane Kruger) to remain in Troy, as well as illustrations showing Greek forces massing to attack the city. One of the storyboards is printed and some feature ink detailing. Handwritten annotations accompany each frame. Dimensions (each page): 29.5 cm x 21 cm (11 1/2" x 8 1/4") Sold without copyright; see copyright notice in the Buyer's Guide.

Estimate. £600 - 800



1492
Edward Cullen's Multnomah Falls Costume Components Ω
Twilight (2008)

Edward Cullen's Multnomah Falls costume components from Lionsgate's blockbuster hit *Twilight*. Edward wore various iterations of his costume when he talked with Bella Swan by the lake and when he visited her in the hospital.

These components consist of a navy-blue windbreaker (size L) hand-marked "TW" with an assortment of pockets and a snap-button-lined zipper front; a grey cotton thermal (size S); and two black trainers with blue accents labelled "Stunt." Also included is a wardrobe tag with character and scene notes. This top piece exhibits minor fraying and the shoes intentionally distressed by production to appear water-damaged.

Estimate. £2,500 - 3,500



1493
Edward Cullen's Hospital Hoodie Ω
Twilight (2008)

Edward Cullen's hospital hoodie from Lionsgate's blockbuster hit *Twilight*. Edward wore his hoodie when he watched over Bella Swan as she recovered in the hospital.

This marled grey cotton blend hoodie (size M) features decorative serged seams in black thread, a red and black drawstring grommet, and a kangaroo pocket. It exhibits wear from production, including a missing drawstring.

Estimate. £1,500 - 2,500



1494
Set of Three Edward Cullen T-Shirts Ω
Twilight (2008)

Three Edward Cullen T-shirts from Lionsgate's blockbuster hit *Twilight*. Edward wore a variety of shirts, including as undershirts in chilly Forks, WA, throughout the film as he wooed Bella Swan.

This set comes directly from Lionsgate. It consists of three cotton T-shirts (all size S), one blue, one light grey, and one dark grey. Each is hand-marked "TW" on the interior collar. The set exhibits minor pilling from age and production wear.

Estimate. £1,000 - 1,500



1495
Bella Swan's Phoenix Costume Components Ω
Twilight (2008)

Bella Swan's Phoenix costume components from Lionsgate's blockbuster hit *Twilight*. Bella wore her button-up shirt over her undershirt when she said goodbye to her mother and stepfather in Phoenix, AZ.

These components consist of a brown and pink plaid cotton button-up shirt (size 4) hand-marked "TW" on the interior with metal snap buttons on the shoulders and front pockets, as well as a grey polyester and cotton long-sleeved shirt (size S) marked "Bella" and "TW." Both exhibit some elastic loss from age.

Estimate. £600 - 800



1497
Bella Swan's Movie Night Costume M
The Twilight Saga: New Moon (2009)

Bella Swan's movie night costume from Lionsgate's blockbuster sequel *The Twilight Saga: New Moon*. Bella wore her outfit to the cinema with Jacob Black and Mike Newton.

The costume consists of a green zip-up hooded jacket; a cream button-up shirt with blue-and-pink embroidery; a pair of jeans; and a pair of casual shoes. The jacket has "NM" handwritten on the label, the trousers have "Bella S" and "NM" handwritten on the label, and each shoe has "Bella" handwritten inside it. The costume is accompanied by two production labels, one of which reads "Bella Hero", while the other lists the numbers of the scenes in which the costume was used.

Estimate. £2,000 - 3,000



1496
Bella Swan's Carver Cafe Cardigan Ω
Twilight (2008)

Bella Swan's Carver Cafe cardigan from Lionsgate's blockbuster hit *Twilight*. Bella wore her cardigan when she and her father Charlie dined at the Carver Cafe.

This brown knitted cotton hooded cardigan (size M) comes directly from Lionsgate. It features grey cotton lining, three brown wood front buttons, two pockets, and "TW" hand-marked on the interior label. The cardigan exhibits some loosening to the sleeves and hood from wear.

Estimate. £500 - 700

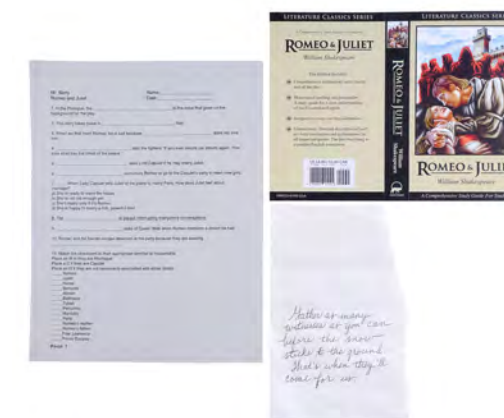

1498
Bella Swan's Test and Book Cover with Alice Cullen's Note to Bella Ω
The Twilight Saga: New Moon (2009)/The Twilight Saga: Breaking Dawn - Part 2 (2012)

Bella Swan's test and book cover with Alice Cullen's note to Bella from Lionsgate's blockbuster sequels *The Twilight Saga: New Moon* and *The Twilight Saga: Breaking Dawn - Part 2*. Bella took a test on Romeo and Juliet in Mr. Berty's class, and later, Alice left a note warning Bella about the Volturi in her copy of *The Merchant of Venice*.

This lot comes directly from Lionsgate. It consists of a production-made Romeo and Juliet book cover; a six-page test labelled "Mr. Berty Romeo and Juliet"; and a title page for "The Merchant of Venice" with cursive notes printed on the reverse. The page is intentionally torn by production. Dimensions (largest): 23 cm x 28 cm (9" x 11"); (smallest): 20.5 cm x 12.75 cm (8" x 5")

Estimate. £500 - 700



1499
 Bella Swan's Striped Henley and Thermal Hoodie Ω
The Twilight Saga: New Moon (2009)/The Twilight Saga: Eclipse (2010)

Bella Swan's striped henley from Lionsgate's blockbuster hit *The Twilight Saga: New Moon* and thermal hoodie from *The Twilight Saga: Eclipse*. Bella wore her striped henley when she spoke with Jacob Black in the final scenes of *The Twilight Saga: New Moon*, and later wore her thermal hoodie when she assured her father, Charlie, that Edward Cullen was appropriately old-fashioned.

This lot comes directly from Lionsgate. It consists of a light blue and heather grey striped cotton henley (size M) with cloth-covered metal buttons and a navy cotton hooded thermal (size M) with orange stripes, metal clasp closures, and "E.C." hand-marked on the interior. The hoodie's tag exhibits fraying.

Estimate. £600 - 800



1501
 Violet's (Milla Jovovich) Auto Pistol $\dagger\Delta$
Ultraviolet (2006)

Violet's (Milla Jovovich) auto pistol from Kurt Wimmer's sci-fi action film *Ultraviolet*. Violet carried her auto pistols throughout the film. The weapon was designed and made for the production, and comprises a pistol inside a black resin housing. It features a moving slide and trigger, and has some minor cracking along the inside of the grip. Dimensions: 21.5 cm x 3.5 cm x 15 cm (8 1/2" x 1 1/2" x 6") Restricted ownership; see replica firearm notice in the Buyer's Guide.

Estimate. £1,500 - 2,500



1500
 Esme Cullen's Stunt Crest Bracelet Ω
The Twilight Saga: Breaking Dawn - Part 1 (2011)

Esme Cullen's stunt crest bracelet from Lionsgate's blockbuster sequel *The Twilight Saga: Breaking Dawn - Part 1*. As a member of the Cullen family, Esme wore her family crest bracelet throughout the film.

This stunt bracelet comes directly from Lionsgate. It features a burnished metal band engraved on the interior to resemble sterling silver with a urethane Cullen family crest glued to the front. The urethane exhibits cracking on the reverse, and the band is discoloured from production use and age.

Estimate. £800 - 1,200



1502
 Violet's (Milla Jovovich) Katana Gun $\dagger\Delta$
Ultraviolet (2006)

Violet's (Milla Jovovich) katana gun from Kurt Wimmer's sci-fi action film *Ultraviolet*. Violet had a pair of sub-machine guns with magazines that doubled as katana-style blades. The gun is made of rubber with a metal barrel, and is accompanied by two blades. One blade is made of foam rubber painted silver, and slots into the grip of the gun. The other is made of resin and metal and features metal faux bullets in one end; this blade does not fit into the gun. The pieces have some minor cracking to the rubber and paintwork, most notably on the rear and top of the gun. Dimensions: 23 cm x 4 cm x 43 cm (9" x 1 1/2" x 17") Restricted ownership; see replica firearm notice in the Buyer's Guide.

Estimate. £1,000 - 1,500



1503
 Franklin State Warriors T-Shirt Ω
Unbreakable (2000)

A Franklin State Warriors T-shirt from M. Night Shyamalan's superhero thriller *Unbreakable*. David Dunn (Bruce Willis) worked security at several Franklin State Warriors football games where fans wore costumes emblazoned with the Warriors' logo. This style of T-shirt was made by production for the stadium scenes, but ultimately unseen in the final cut. The shirt is made of grey cotton (size XL) with a green, red, and goldenrod "Warriors" logo printed on front. It exhibits lost elastic and crinkling from age and handling.

Estimate. £200 - 300



1504
 The Female's (Scarlett Johansson) Lace Top M
Under The Skin (2013)

The Female's (Scarlett Johansson) lace top from Jonathan Glazer's sci-fi horror *Under the Skin*. The Female wore her lace top underneath her pink top, and it was seen most prominently during the scenes in which she seduced and trapped men. The salmon-pink top features lace sections around the midriff, arms and neckline, and a zip runs down the back. The top is accompanied by a letter of authenticity signed by a member of the crew.

Estimate. £500 - 700



1505
 V's (Hugo Weaving) SFX Spinning Knife \dagger
V For Vendetta (2005)

V's (Hugo Weaving) SFX spinning knife from James McTeigue's dystopian drama *V for Vendetta*. V expertly wielded his signature throwing knives throughout the film while working to bring down Britain's oppressive government. This version of the weapon was created for the scenes where V quickly spun the knife in his hand. The knife comprises a thin steel blade featuring a slightly blunted tip, and a black dense-rubber grip decorated with textured silver-metal cord-like detailing. A metal ring is fused to the blade halfway along its length for the actor to slide their finger into, allowing them to spin the knife around freely. Dimensions: 39 cm x 7.5 cm x 3.5 cm (15 1/4" x 3" x 1 1/2")

Estimate. £2,000 - 3,000



1506
Colonel Claus Von Stauffenberg's (Tom Cruise) Uniform \dagger
Valkyrie (2008)

Colonel Claus Von Stauffenberg's (Tom Cruise) uniform from Bryan Singer's World War II thriller Valkyrie. Von Stauffenberg wore his uniform throughout the film as he and a group of disaffected officers conspired to assassinate Adolf Hitler (David Bamber). This lot includes a light green jacket, which features an embroidered Nazi Eagle symbol on the right chest; a faux collar; decorated epaulettes; silver collar boards; a German Cross badge; and a faux-gold Wound Badge. The lot also includes a pair of trousers with crimson panels running vertically down the side of each leg, and a feldgrau (field-grey) cotton cap featuring a dark green felt band, a black plastic peak and two silver-tone braids. The front of the cap displays a metal Nazi Eagle emblem and a faux-silver oak-leaf insignia surrounding a central cockade. Each piece exhibits Cruise's name hand-marked on labels attached to its interior, and corrosion to the metal detailings from production use. Additionally, the jacket exhibits unstitching along the armhole seam.

Estimate. £3,000 - 5,000



1507
Victor Crowley's (Kane Hodder) Overalls Ω
Victor Crowley (2017)

Victor Crowley's (Kane Hodder) overalls from Adam Green's slasher sequel Victor Crowley. Supernatural psychopath Crowley wore his overalls as he was accidentally resurrected, which gave him a chance to continue on his homicidal killing spree. These blue denim overalls were deliberately distressed by production, with rips and blood stains throughout. Also included is an ArieScope Pictures Certificate of Authenticity signed by director Adam Green. The overalls exhibit some additional wear, including fraying to the ends of the pant legs and a split in the back.

Estimate. £1,500 - 2,500



1508
Ray Ferrier's (Tom Cruise) "Virgin" Leather Jacket and Rachel Ferrier's (Dakota Fanning) Third Place Rosette \mathcal{M}
War Of The Worlds (2005)

Ray Ferrier's (Tom Cruise) "Virgin" leather jacket and Rachel Ferrier's (Dakota Fanning) rosette from Steven Spielberg's sci-fi thriller War of the Worlds. Ray wore his jacket throughout the film, and Rachel played with a rosette and toy horses when she explained she had a splinter in her finger. The custom-made brown leather jacket features red-and-white stripe detailing on the sleeves, a label reading "Actual Jkt #1 - Virgin" sewn to the lining, and a John David Ridge label marked "Regular Size" in its internal pocket. The yellow ribbon rosette features metallic text reading "Uset Festival of Champions, Third Place", and has a "Congratulations" label adhered to the back. The lot comes with an original costume reference tag. Dimensions (rosette): 23 cm x 13 cm x 1 cm (9" x 5 1/4" x 1/2")

Estimate. £3,000 - 5,000



1509
Ray Ferrier's (Tom Cruise) Blue Hoodie Costume \mathcal{M}
War Of The Worlds (2005)

Ray Ferrier's (Tom Cruise) blue hoodie costume from Steven Spielberg's sci-fi horror War of the Worlds. Ray can be seen wearing this costume throughout the film's first half, as he attempted to lead his children to safety after aliens attacked Earth. The costume consists of a navy fleece zip-up hoodie, an olive Juicy Couture t-shirt labelled size M, a blue unisex t-shirt, and a pair of jeans made by Paper Denim & Cloth, which feature the size "33" handwritten on the manufacturer's tag. Accompanying this costume is a production label which notes that this costume was used aboard the "ferry" in scenes 79-98.

Estimate. £1,500 - 2,500



1510
Rachel Ferrier's (Dakota Fanning) Costume \mathcal{M}
War Of The Worlds (2005)

Rachel Ferrier's (Dakota Fanning) costume from Steven Spielberg's sci-fi horror War of the Worlds. Rachel wore her costume throughout the film, with several progressively distressed versions made for the production. The costume consists of a long-sleeved pink top, labelled size M and featuring a beaded flower motif on its front, and a mustard knitted sweater with multi-coloured striped sleeves. The costume remains relatively undistressed, apart from some black staining applied to the sweater's sleeves, indicating that it was likely used during the film's opening sequence. Additional wear from production use includes a small hole in the top's right sleeve.

Estimate. £800 - 1,200



1511
Original Hand-painted Costume Design Artworks \mathcal{M}
War Of The Worlds (2005)

A set of original costume design artworks hand-painted by the Costume Designers Guild Award-winning Joanna Johnston, from the production of Steven Spielberg's sci-fi horror War of the Worlds. This set comprises coloured costume designs for Ray (Tom Cruise) and Rachel Ferrier (Dakota Fanning), significantly Ray's signature leather jacket, rendered in a mix of watercolour and pencil on five pages of A3 watercolour paper. Each artwork features Johnston's signature and a stamp that reads "Designed by Joanna Johnston". Accompanying these designs is a photographic still and a magazine cut-out of Cruise on set. The pages exhibit smudges and small tears in the perforated top edge, from where each sheet has been removed from its drawing pad. Dimensions (each sheet): 40.5 cm x 30.5 cm (16" x 12") Sold without copyright; see copyright notice in the Buyer's Guide.

Estimate. £800 - 1,200



1512
Alliance Knight's Shield with Foot Soldier Sword Ω
Warcraft (2016)

An Alliance knight's shield with a foot soldier's sword from Legendary Pictures' fantasy epic Warcraft. Royal guards and knights of the Alliance, along with more humble foot soldiers, defended King Llane (Dominic Cooper) against the Orc Horde invading Azeroth. This lot consists of a urethane shield with a metallized Stormwind lion emblem moulded to the front and leather arm straps with brass buckles affixed on the reverse, as well as a urethane sword with a rune-engraved blade, a blue ridged grip, and blue faux gems inset in the hilt. Both are distressed by production to appear battle-worn with nicks, scrapes, and applied grime. Dimensions (shield): 66 cm x 56 cm x 15.25 cm (26" x 22" x 6"); (sword): 119.5 cm x 25.5 cm x 9 cm (47" x 10" x 12")

Estimate. £2,500 - 3,500

1513
Alliance Foot Soldier's Sword, Scabbard, and Shield Ω
Warcraft (2016)

An Alliance foot soldier's sword, scabbard, and shield from Legendary Pictures' fantasy epic Warcraft. Alliance foot soldiers wielded blue and silver-colour weaponry battling the Orc Horde. This lot consists of a urethane sword with a silver-colour engraved blade and blue ridged grip; a matching urethane shield with leather straps engraved with a Stormwind lion; and an engraved brown leather scabbard. The sword is missing a gem, and the shield is intentionally distressed by production to appear battle-used. Dimensions (sword): 108 cm x 25 cm x 4.5 cm (42.5" x 9.75" x 1.75"); (shield): 84 cm x 63.5 cm x 13 cm (33" x 25" x 5")

Estimate. £1,500 - 2,500

1514
Alliance Knight's Shield Ω
Warcraft (2016)

An Alliance knight's shield from Legendary Pictures' fantasy epic Warcraft. Royal guards and knights of the Alliance defended King Llane (Dominic Cooper) against the Orc Horde invading Azeroth. This urethane shield is painted silver-colour and blue to resemble steel with a metallized Stormwind lion emblem moulded to the front and leather arm straps with brass buckles affixed on the reverse. It is extensively distressed by production to appear battle-worn with nicks, dents, and scratches throughout. Dimensions: 63.5 cm x 51 cm x 12.75 cm (25" x 20" x 5")

Estimate. £1,500 - 2,500



1515
Alliance Hand Cannon Ω
Warcraft (2016)

An Alliance hand cannon from Legendary Pictures' fantasy epic Warcraft. Foot soldiers of the Alliance used hand cannons when they battled the Orc Horde at the dark portal. This ornate, moulded rubber hand cannon with an affixed rubber axehead and gold-colour trim is painted brown to appear wooden. It also features a leather strap. The cannon is intentionally distressed by production to look tarnished and worn from battle use with cracking and discolouration throughout the rubber. Dimensions: 73.75 cm x 20.5 cm x 5.25 cm (29" x 8" x 2") Ownership may be restricted in some countries; see replica firearm notice in Buyer's Guide.

Estimate. £1,200 - 1,800



1517
Set of Six Slate Covers Ω
Warcraft (2016)

Six slate covers from the production of Legendary Pictures' fantasy epic Warcraft. Director Duncan Jones used two cameras to capture 3D imagery for VFX shots, requiring alternate covers for slates used to differentiate the cameras. This set consists of one small and one large acrylic "A" camera slates printed with the production logo, director "Duncan Jones," and cinematographer "Simon Duggan"; two matching "B" camera slates; and matching "C" and "D" slates. They exhibit scratching, scuffing, and staining throughout. Dimensions (largest): 28 cm x 20.5 cm x 0.75 cm (11" x 8" x 0.25"); (smallest): 14 cm x 10.25 cm x 0.75 cm (5.5" x 4" x 0.25")

Estimate. £600 - 800



1516
Alliance Foot Soldier Sword Ω
Warcraft (2016)

An Alliance Foot Soldier sword from Legendary Pictures' fantasy epic Warcraft. Foot soldiers of the Alliance wielded their blue and silver Stormwind swords in battles with the invading armies of the Orc Horde. This urethane sword features a silver-colour blade engraved with runes, a blue urethane gem inset in the hilt, and a ridged grip painted blue with a diamond-shapedommel. Grime is applied throughout the blade by production, and paint is flaking off the hilt, exposing the urethane. Dimensions: 107 cm x 17.75 cm x 7.75 cm (42" x 7" x 3")

Estimate. £800 - 1,200

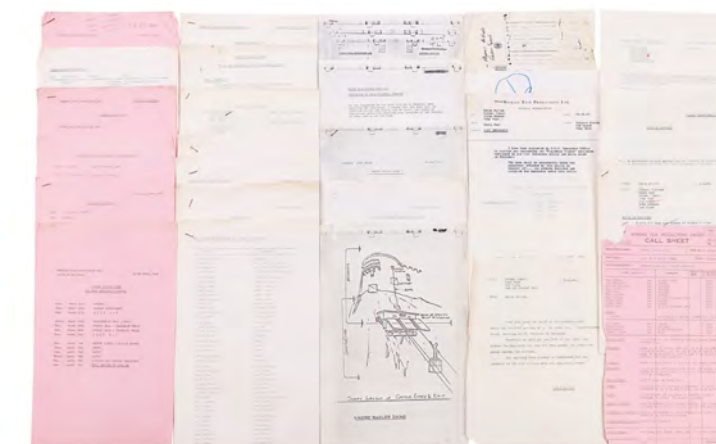

1518
Collection of Production Paperwork Ω
Where Eagles Dare (1968)

A collection of production paperwork from Brian G. Hutton's WWII film Where Eagles Dare. This collection of paperwork includes various memos to and from director Hutton; a call sheet; an annotated unit list for the Austrian; printed notes about stunts and location facilities; and other production ephemera. Some of the pages feature handwritten notes and doodles. Several of the pages are stapled together. Dimensions: 34 cm x 22 cm x 1 cm (13 1/2" x 8 3/4" x 1/2")

Estimate. £300 - 500



1519
 Richard Williams Hand-drawn Artwork of Roger Rabbit and Jessica Rabbit
 Who Framed Roger Rabbit (1988)

A Richard Williams hand-drawn sketch of Roger Rabbit and Jessica Rabbit from the production of Robert Zemeckis' Oscar®-winning detective comedy Who Framed Roger Rabbit. Animation director Williams won two Academy Awards® for his work on the movie, including a Special Achievement Award. This artwork was originally donated by Aardman Animations to the "Mia Lloyd Fundraising Animation Auction", which took place online in 2017. Titled "The Happy Couple", the sketch is rendered in pencil and coloured crayon and is signed by Williams. The lot is accompanied by a letter of authenticity from Senior Animation Supervisor at Aardman Mathew Rees (now Head of CG Animation). Dimensions: 37 cm x 25 cm (14 1/2" x 9 3/4") Sold without copyright; see copyright notice in the Buyer's Guide.

Estimate. £3,000 - 5,000



1520
 Philip Kohler Collection: Acme Large Pill Packing Box and Product Label Design Prints
 Who Framed Roger Rabbit (1988)

An Acme large pill packing box and label design prints from the production of Robert Zemeckis' Oscar®-winning detective comedy Who Framed Roger Rabbit. Large pill boxes, glue and disappearing ink, were part of the vast stock of products seen in the Acme warehouse. This lot comes from the personal collection of renowned production manager Philip Kohler. The flattened cardboard packing box has "Acme Large Pills" spray-painted in red and black stencilled letters on both sides, and both full-colour label designs feature the Acme brand. There are marks and remnants from tape strips on the box. Dimensions (box): 99 cm x 41.5 cm x 1.5 cm (39" x 16 1/4" x 1/2"); (larger print): 30 cm x 42 cm (11 3/4" x 16 1/2")

Estimate. £600 - 800



1521
 Philip Kohler Collection: Set of Acme Glue Disappearing Ink Label Design Prints
 Who Framed Roger Rabbit (1988)

A set of Acme glue and disappearing ink label design prints from the production of Robert Zemeckis' Oscar®-winning detective comedy Who Framed Roger Rabbit. Glue and disappearing ink were part of the vast stock of products seen in the Acme warehouse. This lot comes from the personal collection of renowned production manager Philip Kohler. The set consists of nine "Glue, Extra Sticky" label prints and two "Disappearing & Re-appearing Ink" label prints, all in full colour on paper and featuring the Acme brand. Dimensions (glue label print): 30 cm x 42 cm (11 3/4" x 16 1/2"); (ink label print): 30 cm x 21 cm (11 3/4" x 8 1/4")

Estimate. £400 - 600



1522
 Pair of Flying Monkey Masks
 Wicked (West End Theatre)

A pair of flying monkey masks from the long-running hit stage musical based on the characters from the Wizard of Oz, Wicked. All the masks for the Broadway show were created by the make-up effects company W.M. Creations, Inc. These masks are made from foam rubber and latex and feature long brown plastic hairs that have been hand-punched into the skull. Each mask was uniquely hand-painted in red, and brown tones, with additional make-up applied for each performance. Names written in black pen on the inside identify these masks to have been worn by "Jared" and "Mitchell". The masks exhibit wear from production use, including peeling areas of painted latex. Dimensions (each): 31 cm x 21 cm x 32 cm (12 1/4" x 8 1/4" x 12 1/2")

Estimate. £500 - 700



1524
 Hand-illustrated and Printed Nockmaar Castle Matte Painting Concept Artworks
 Willow (1988)

Hand-illustrated and printed Nockmaar Castle matte painting concept artworks from the production of Ron Howard's fantasy film Willow. These two artworks were created by Industrial Light & Magic (ILM) as concepts for matte paintings of Queen Bavmorda's (Jean Marsh) home. This lot consists of one artwork of Nockmaar hand-rendered in mixed media on illustration board and one marked "I.A.?" and "MP 30" which consists of a printed photograph of soldiers at the castle with hand-illustrated additions on the castle and black tape borders. They exhibit stray paint and marker splotches and doodles, as well as adhesive residue and damage. Dimensions (largest): 20.5 cm x 30.5 cm (8" x 12"); (smallest): 20.5 cm x 26.25 cm (8" x 10.25") Sold without copyright; see notice in the Buyer's Guide.

Estimate. £1,500 - 2,500

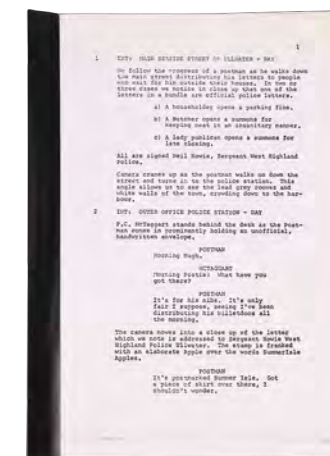

1523
 Sir Christopher Lee-owned Script
 Wicker Man, The (1973)

A script owned by Sir Christopher Lee from the production of Robin Hardy's mystery thriller The Wicker Man. This item comes from the personal collection of legendary actor Sir Christopher Lee. The script is 120 pages long and is held together with a plastic spine. It is unannotated and has some minor staining on some of the pages. Dimensions: 30 cm x 21.5 cm x 2 cm (11 3/4" x 8 1/2" x 3/4")

Estimate. £800 - 1,200



1525
 50th Anniversary Hand-drawn Concept Artwork by Mark Hobson
 Wizard Of Oz, The (1939)

Hand-drawn concept artwork by Mark Hobson for the 1989 50th Anniversary VHS release of Victor Fleming's fantasy musical The Wizard of Oz. This pencil artwork is rendered on a sheet of tracing paper, which is fastened to a larger piece of white paper and protected by a semi-transparent sheet taped to its top edge. The drawing features the header "Fiftieth 50 Anniversary" and the film's title at the centre of the composition, above which is a line of portraits featuring the Cowardly Lion (Bert Lahr), the Scarecrow (Ray Bolger) and the Tin Man (Jack Haley). A larger portrait of Dorothy (Judy Garland) is positioned below. Dorothy is framed by detailed sketches of other characters, with the Emerald City in the background to her left. The lot exhibits some wear, including creased edges and a tear at the top left of the protective layout paper. Dimensions: 43 cm x 28 cm (17" x 11") Sold without copyright; see copyright notice in the Buyer's Guide.

Estimate. £1,000 - 1,500



1526
Zombie Test Bust †Δ
World War Z (2013)

A zombie test bust from Marc Forster's zombie apocalypse film World War Z. This test bust was used in the design process to finalise the look of the infected zombie humans seen throughout the film. The bust depicts a bald male zombie with bite marks, deep cuts and abrasions to his nose, neck, jaw, earlobe and collarbones. Gaunt, cadaverous, and with several raised veins, the zombie has assumed a melancholic and somewhat ruminative facial expression. The bust is made on a fibreglass life cast upon which foam latex has been applied, together with an airbrush finish, to create a fleshy texture and a remarkably lifelike appearance. The shirt is made of cotton. Dimensions: 24.5 cm x 49 cm x 44.5 cm (9 3/4" x 19 1/2" x 17 1/2")

Estimate. £1,000 - 1,500

1527
Alien Ship Fragment Ω
X-Files, The (T.V. Series, 2002)

An alien ship fragment from Chris Carter's sci-fi mystery series The X-Files. In Season 9 episode 9, "Provenance," Agent Robert Comer (Neal McDonough) used the alien ship fragment he stole to heal himself after getting into a motorcycle crash. This lot consists of a solid resin fragment painted silver-colour and textured to look like metal striations. It features carved "alien" writing on one side and a flat back. The fragment exhibits discolouration, notable black paint marks, and holes from the casting process. Dimensions: 11.5 cm x 6.5 cm x 1.5 cm (4.5" x 2.5" x 0.5")

Estimate. £3,000 - 5,000

1528
"Miracle Ends Controversy"
Newspaper †
X-Files, The (T.V. Series, 1993 - 2018)

A newspaper from the sci-fi series The X-Files. In the Season 7 episode "En Ami" Scully (Gillian Anderson) handed Mulder (David Duchovny) a newspaper with the headline "Miracle Ends Controversy", kicking off their investigation into how a boy recovered from cancer overnight. The paper's cover page features filler articles and the pages inside are an old copy of the Los Angeles Times.

Estimate. £400 - 600

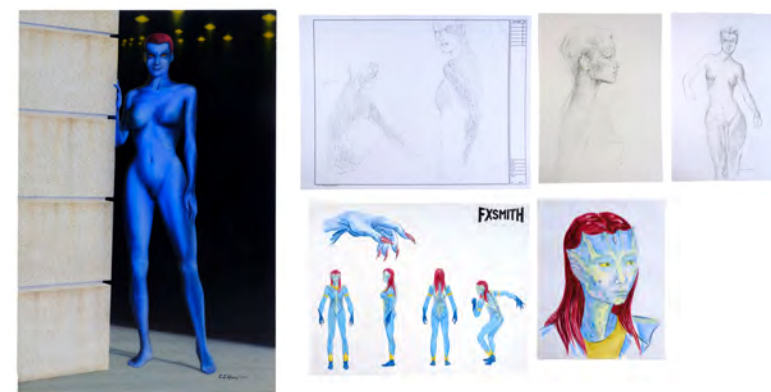

1529
Set of Six Hand-Drawn Mystique Concept Artworks Ω
X-Men (2000)

Six Mystique concept artworks hand-drawn for the production of Bryan Singer's superhero film X-Men. Mystique (Rebecca Romijn) transformed out of her natural blue skin to force a war between mutants and humans. This set consists of a Tania Richard-signed bust and body sketch, a C.S. Herel-signed painting, two Gretchen Sanchez-signed concept design sketches, and a re-visioned character design concept sketch, all of Mystique. The set is rendered in mixed media on paper and various boards. Also included are six Certificates of Authenticity from effects company FX Smith. The sketches exhibit edge fraying and the painting exhibits minor corner folding from production. Dimensions (largest): 44.5 cm x 64.25 cm (17.5" x 25.25"); (smallest): 28 cm x 36.25 cm (11" x 14.25") Sold without copyright; see copyright notice in the Buyer's Guide.

Estimate. £1,500 - 2,500

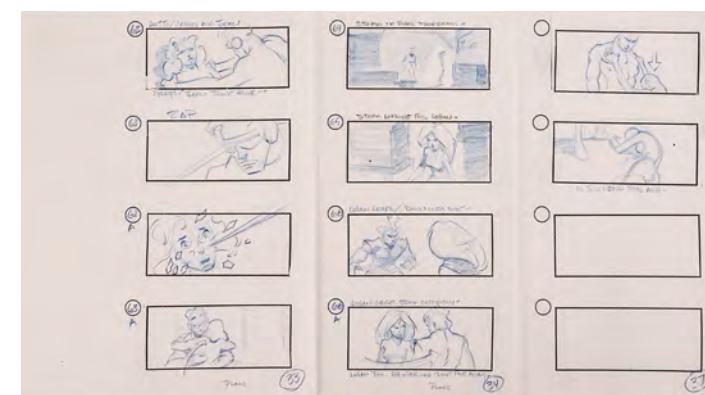

1531
Set of Hand-Drawn Pencil Storyboards of Wolverine Confronting Mystique †Δ
X-Men (2000)

A set of hand-drawn storyboard pages from the production of Bryan Singer's superhero film X-Men. The lot consists of ten storyboards drawn onto three sheets of paper. These storyboards depict when Wolverine (Hugh Jackman) confronted Mystique (Rebecca Romijn-Stamos) disguised as Storm, and one page shows Cyclops (James Marsden) coming to the aid of Jean Grey (Famke Janssen). Drawn by storyboard artist Mike Ploog, each blue-coloured pencil rendered image is labelled with a number, a brief description of the scene, and some feature directional arrows. Pinholes are present on each page from production use. Dimensions (each sheet): 28 cm x 21.5 cm (11" x 8 1/2") Sold without copyright; see copyright notice in the Buyer's Guide.

Estimate. £500 - 700

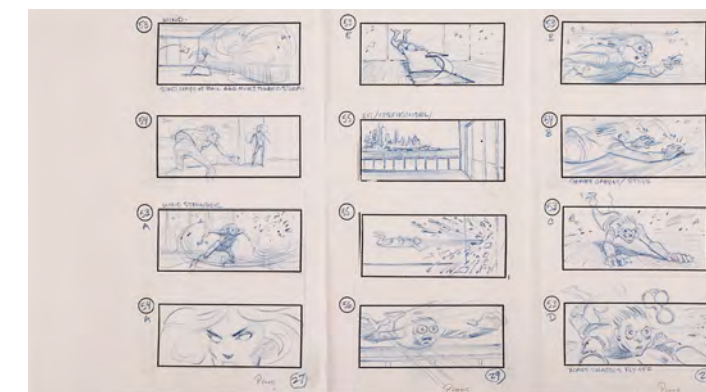

1530
Set of Hand-drawn Pencil Storyboards Storm Attacking Toad †Δ
X-Men (2000)

A set of hand-drawn storyboard pages from the production of Bryan Singer's superhero film X-Men. The lot consists of twelve storyboards drawn onto three sheets of paper. These storyboards depict Storm (Halle Berry) using wind and lightning to attack Toad (Ray Park), forcing him to fall into the Hudson River. Illustrated by storyboard artist Mike Ploog, each blue-coloured pencil rendered image is labelled with a number, and some feature a brief description of the scene. Pinholes are present on each page from production use. Dimensions (each sheet): 28 cm x 21.5 cm (11" x 8 1/2") Sold without copyright; see copyright notice in the Buyer's Guide.

Estimate. £500 - 700



1532
Collection of Printed Concept Art, Storyboards, Reference Photos, and Crew Ephemera Ω
X2: X-Men United (2003)/X-Men: The Last Stand (2006)

A collection of production materials and crew ephemera from the superhero films X2: X-Men United and the sequel X-Men: The Last Stand. This lot consists of 25 colour prints of concept designs for Nightcrawler and a sentinel by James Oxford and Ricardo Delgado. It also contains two printed collages of Vatican City; an album containing printed set designs and reference photographs with a Guy Hendrix Dyas-signed card; and a laminated Magneto crew pass. Also included are binders containing printed concept illustrations and key sequence storyboards. All exhibit folding, edge wear, and stains throughout from production and age. Dimensions: 56 cm x 45.75 cm x 30.5 cm (22" x 18" x 12")

Estimate. £800 - 1,200



1533
Production Clapperboard M
X-Men: The Last Stand (2006)

A clapperboard from the production of Brett Ratner's superhero sequel X-Men: The Last Stand. The clapperboard comprises an acrylic slate and a wooden clapper. The slate features director Ratner and cinematographer Dante Spinotti's names beneath sections for the roll, scene and take numbers. The slate is decorated with the film's logo and the faces of Wolverine (Hugh Jackman), Jean Grey (Famke Janssen), Rogue (Anna Paquin), Storm (Halle Berry) and Professor Xavier (Patrick Stewart). Dimensions: 24 cm x 28 cm x 2 cm (9 1/2" x 11" x 3/4")

Estimate. £1,500 - 2,500



1534
Xena's (Lucy Lawless) Winged Helmet and Replica Chakram Ω
Xena Warrior Princess (T.V. Series 1995 - 2001)

Xena's (Lucy Lawless) winged helmet and replica chakram from the action adventure series Xena: Warrior Princess. In the Season 6 episode "Return of the Valkyrie," Xena wore her helmet while wielding her signature weapon. This lot consists of a silver-colour leather helmet with urethane embellishments and "Xena" handwritten inside; a chrome-and-gold-coloured metal replica chakram featuring an inner edge with a Grecian-inspired meander and faux abalone shell; instructions for the chakram; an Icons Authentic Replicas Certificate of Authenticity; and an Icons "Winter 1997/1998" catalogue. The helmet exhibits cracking and paint chipping, while the chakram exhibits minor scratches and paint chipping. Dimensions (chakram): 25 cm x 25 cm x 1 cm (10" x 10" x 0.5")

Estimate. £800 - 1,200



1535
Set of Lobby Cards and One-Sheets Ω
Zulu (1964)

Lobby cards and one-sheets from the promotion of Cy Endfield's war epic Zulu. Karsh is considered one of the foremost portraitists in history for his photographs of Winston Churchill and President Eisenhower, among others. This set consists of eight colour-printed Paramount Pictures lobby cards, each dated "1963" and numbered "64/36," as well as two original colour-printed one-sheets, one in Italian printed by Policrom S.p.A. and one in French printed by SAINT-MARTIN. Both one-sheets are folded, and the lobby cards exhibit some staining. Dimensions (largest): 58.5 cm x 81.5 cm (23" x 32"); (smallest): 28 cm x 35.75 cm (11" x 14") Sold without copyright; see copyright notice in the Buyer's Guide.

Estimate. £700 - 900



1536
Set of Yousuf Karsh Cast Photographs Ω
Zulu (1964)

Cast photographs shot by Yousuf Karsh for Cy Endfield's war epic Zulu. Considered one of the foremost portraitists in history for his photographs of Winston Churchill and President Eisenhower, among others, Karsh shot images of the cast for Embassy Films throughout production in 1963. This set consists of eight black-and-white behind-the-scenes photographs of key cast members, including Michael Caine, Ulla Jacobsson, Jack Hawkins, and Chief Buthelezi of the Zulu Nation. Each is hand-numbered in graphite and annotated with image references on the back. Some also feature stickers applied with image credits for "Karsh, Ottawa." The set exhibits minor bending. Dimensions (each): 28 cm x 35.75 cm (11" x 14")

Estimate. £2,000 - 3,000

VAT Quick Reference Guide

VAT Status	Buyer Location / Business or Individual	VAT on Hammer Price	VAT on Buyer's Premium	VAT on Buyer's Expenses
Standard Rules (†)	UK & NI / Individual	20%	20%	20%
	UK & NI / Business	20%	20%	20%
	Rest of World / Individual	0%	20%	20%
	Rest of World / Business	0%	0%	0%
Temporary Import (Ω)	UK & NI	5%	20%	20%
	Rest of World	0%	0%	0%
Margin Scheme (M)	UK	0%	20%	20%
	NI	20%	20%	20%
	Rest of World	0%	0%	0%
Items Outside UK (US and EU)	UK & NI	0%	20%	20%
	Rest of World	0%	0%	0%

Special Notices

Notice on Lots Requiring Special Shipping

Lots with this disclaimer, due to their size and/or nature (including lots which may be shipped from offsite) will require specialist shipping service with additional cost. Buyer will be responsible for all shipping costs of Lots. Bidders are strongly advised to contact Propstore for a shipping quote prior to bidding on these Lots.

Notice on Off-site Storage

Some lots in the auction are stored off-site, outside of Propstore's primary facility. They may be stored in another State and therefore will ship from their current location to Buyer's location, at Buyer's expense. These lots will not be available to preview before the auction without special arrangements. Buyer will be responsible for all shipping costs of Lots, regardless of Lot storage location. Please contact Propstore for a shipping quote prior to bidding on off-site storage lots.

U.K. Storage

Certain Lots are currently located in Propstore's London facility and will ship directly to the buyer from the London facility. Any such Lots will be identified in the catalogue with the symbol U.K. next to its lot number. Buyer will be responsible for all shipping and import charges from the U.K. See clause 5.3.3 of Terms & Conditions and please inquire for additional information.

Propstore Interest Δ

From time to time, Propstore may offer a Lot which it owns in whole or in part or in which it has a financial interest and any such Lot will be identified in the catalogue with the symbol Δ next to its Lot number.

Notice on Electronics and Mechanics

Some lots in the auction contain contain electronic and/or mechanical components. While every effort is made to describe them accurately, no guarantee or warranty is made as to the functionality, lifespan or safety of those components. It is entirely incumbent on the new owner to satisfy themselves as to their safe use and maintenance.

Notice on Copyright

Lots with this disclaimer are sold without copyright, reproduction rights, licencing agreements or any other type of legal release.

Notice on U.S. Live Firearms

This item is a firearm stored in the U.S., and while it may have been modified for film industry use and is sold for collectible purposes only, it is legally a firearm it must be transferred to a U.S. buyer through a Federal Firearms License dealer. The firearm may transfer from Propstore, or directly from the consignor, to Buyer's local FFL dealer. Propstore will coordinate with Buyer on all transfers. Buyer will then have to go through the necessary steps to transfer the firearm from your local FFL dealer to yourself, which vary state by state. All costs associated with the transfer will be the Buyer's responsibility. Exporting the piece to the U.K. or Europe may be possible if it is deactivated at additional cost; please inquire for details.

Notice on Firearm Deactivation

Firearms with this disclaimer have been permanently and sympathetically deactivated to U.K. legal requirements and no longer retains any functional capacity to fire; a U.K. proof house certificate of deactivation is included. For buyers within the U.S., these Lots may still need to transfer through a Federal Firearms Dealer (see notice on U.S. Live Firearms.) It is solely the buyer's responsibility to check, prior to bidding, the legal status of this weapon within their own country and the importation therein. All costs associated with the transfer will be the buyer's responsibility.

Notice on Replica Firearms and UK Restrictions

Replica firearms Lots will ship with a blaze orange plug affixed to their barrel tip (plug is not depicted in catalogue illustrations.) Buyers should be aware that ownership of Lots with this disclaimer is restricted for UK residents to registered re-enactors, galleries, or individuals in film, television, or theater production. Please inquire for further details. There may be restrictions applicable to Buyers in other countries as well; it is solely the Buyer's responsibility to check, prior to bidding, the legal status of this item within their own country and the importation therein.

Privacy Policy

By registering for this auction, you consent to us contacting you regarding your bidding activity and about important updates regarding the running of the auction. We will not pass your information on to any third parties. You can view our privacy policy at propstore.com/privacy-policy/

Buyer's Guide

1. Introduction

This Buyers' Guide contains a brief overview of Propstore's auction process and the terms under which Lots are made available for sale at auction. A more detailed statement of our Terms and Conditions of Sale follows after this Buyer's Guide. Please read the Buyer's Guide and the Terms and Conditions of Sale carefully. By registering to bid and participate in a Propstore auction, you will be deemed to have agreed to be bound by them..

2. Definitions

2.1. When the following words are used in this Buyer's Guide, they mean:

Auction	A live sale by auction hosted by Propstore
Bidder	Any person, properly registered and approved by Propstore to participate in an Auction who makes or considers making a bid to buy a Lot at Auction
Buyer	The person or organisation making the highest bid or offer for a Lot accepted by the auctioneer, including a principal bidding as agent
Buyer's Expenses	A fee of 5% of the Hammer Price charged to the Buyer for a Lot won on any bidding platform other than propstoreauction.com
Buyer's Premium	A commission of 25% (or £30, whichever is higher) plus VAT if applicable) of the Hammer Price for a Lot, payable by the Buyer to Propstore
Company	Any partnership, corporation, limited liability company, association, or any other business entity duly organized and qualified to conduct business under the laws of its state of formation
Cryptocurrency	Cryptocurrency means the virtual or digital currency accepted by Propstore as payment, using our chosen payment processor. The current list of the forms of Cryptocurrency we accept are set out on our website at propstore.com/cryptocurrency
Guarantee of Attribution	Propstore's limited guarantee relating to the provenance of each Lot, given to the extent set out in Condition 10 of the Terms and Conditions of Sale
Hammer Price	The highest bid for a Lot accepted by the auctioneer at the Auction or the post-Auction sale price of that Lot
Lot	Each item or group of items consigned by the Seller to Propstore to be made available for sale at an Auction, as detailed in the catalogue
Propstore	Propstore Limited (company number 08622002) of Great House Farm, Chenies, Rickmansworth, WD3 6EP
Purchase Price	The Hammer Price plus the Buyer's Premium, any applicable Buyer's Expenses and any applicable sales tax and/or VAT, charged to the Buyer
Reserve Price	(Where applicable) the minimum price at which the Seller has authorised Propstore to sell a Lot
Seller	The person or organisation offering the Lot for sale, including their agents or personal representatives
Terms and Conditions of Sale	Propstore's Terms and Conditions of Sale at Auction, from time to time as may be amended, a copy of which appears following the Buyer's Guide

3. Before the Auction

3.1. Bidder Registration

- 3.1.1. Every person or organisation wishing to make a bid is required to register with Propstore before participating at an Auction.
- 3.1.2. To register, the registration form (available in this Buyer's Guide or online at propstore.com) must be completed in full and Propstore provided with valid Visa, MasterCard or American Express credit card details to be held on file; and
 - 3.1.2.1. at least one (1) form of ID is required which must include one (1) government-issued photo identification. If this does not state your current address, proof of address will also be required.
 - 3.1.2.2. an organisation must provide a certified copy or original certificate of incorporation, or, in the case of unregistered entities, other evidence satisfactory to Propstore contact Propstore on +44 (0)1494 766485 for confirmation of what will be acceptable;
 - 3.1.2.3. a person registering as an agent to bid on behalf of a third party must bring the appropriate identification documents as set out above for themselves and for the third party on whose behalf they are authorised to make a bid and provide to Propstore a signed authorisation from the third party confirming their authority to participate at the Auction on that third party's behalf.

3.2. Pre-Auction Viewing

- 3.2.1. During the Pre-Auction Viewing period, as set forth in the Auction catalogue, any Bidder may preview Lots free of charge by appointment with Propstore..

3.3. Delivery Costs

- 3.3.1. Without any liability, Propstore can provide shipping estimates before the Auction; a Bidder requiring this information should email shipping@propstore.com including the Lot number and shipping address at least 3 working days before the start of the Auction.

Buyer's Guide

3.4. Bidders outside the U.K.

- 3.4.1. If the Bidder is based outside the United Kingdom, the Bidder should ensure in advance of the Auction that the Lot can be exported from the U.K. and imported into the country of destination. No sale will be cancelled because the Lot may not be imported into the country of destination.
- 3.4.2. Propstore's recommended third-party independent freight agent, Precision Cargo, can advise Bidders on relevant export licensing regulations and may submit export licence applications upon request. Neither Propstore nor its freight agents can guarantee that any licences, permits or consents will be granted.

4. At the Auction

4.1. Estimates

- 4.1.1. Estimates represent Propstore's guide to Bidders and do not give any indication or representation of actual values or likely bids. Estimates do not include any Buyer's Premium, Buyer's Expense, VAT or sales tax.
- 4.1.2. Propstore reserves the right to amend its estimates from time to time.

4.2. Reserve Price

- 4.2.1. The Reserve Price is the minimum price the Seller will accept for a Lot. The Reserve Price will not be more than the lowest estimate given by Propstore. Propstore may disclose or keep confidential the Reserve Price at its entire discretion.

4.3. Bidding

- 4.3.1. All bids are by individual Lot unless the auctioneer states to the contrary during the live Auction. Lots will usually be sold in their numbered sequence, unless the auctioneer announces otherwise.
- 4.3.2. All bids must be made in English only.
- 4.3.3. The auctioneer may accept bids from Bidders present in the sale room, via telephone, online or written bids delivered to Propstore before the Auction commences, either using the form in this Buyer's Guide or the online form at propstore.com.
- 4.3.4. Telephone Bidders must provide to Propstore a list of Lots on which they intend to bid at least 24 hours before the start of the Auction. Telephone bids will only be accepted on Lots with low-end estimate of at least £500 and telephone calls may be recorded by or on behalf of Propstore.
- 4.3.5. Written bids will be executed at the lowest possible price, taking into account the Reserve Price.
- 4.3.6. Online bids shall be made in accordance with and subject to the terms of the online auction platform access provider.
- 4.3.7. The auctioneer may also execute (non-identified) bids on behalf of the Seller up to the Reserve Price only. No bids may be made by the Seller in excess of the Reserve Price
- 4.3.8. Save as expressly stated in this Buyer's Guide, Propstore accepts no liability for errors or omission in respect of bids made online, by telephone or in writing
- 4.3.9. The auctioneer may accept or decline bids at his entire discretion.
- 4.3.10. At its discretion, Propstore reserves the right to apply a bidding cap or suspend bidding privileges to individual bidders at any point during the auction period. The cap will be withdrawn once evidence has been submitted to Propstore's satisfaction that all bids are genuine, the bidder has the means to complete the purchase(s) and any other security checks Propstore may be obliged to carry out have been completed.

5. After the Auction

5.1. Successful bids

- 5.1.1. Propstore will notify successful Bidders and send (by email unless requested otherwise) a payment invoice setting out the Purchase Price and itemising the Hammer Price and Buyer's Premium, plus any applicable VAT within 7 calendar days of the end of the Auction.

5.2. Payment

- 5.2.1. Payment is due within 7 calendar days from receipt of invoice and must be made by the Buyer. Payments from any other source will not be accepted and shall be returned by Propstore.
- 5.2.2. Payment must be made in Pounds Sterling and may be made by electronic transfer, debit card, credit card (up to a maximum of £25,000) bankers draft or cash (up to a maximum of £5,000). Please quote the Lot number, invoice number and Bidder registration number when making payment to ensure it can be processed as efficiently as possible.
- 5.2.3. Credit card payments are only acceptable on the express understanding that the Lot is not returnable, refundable nor exchangeable and no charge card credit may be issued in the event of any such return. If payment is made by credit card, Buyer will not undertake any action or effort to stop payment, seek a refund, or attempt a charge back of such amounts – or any Credit Card Fee assessed thereon – by the issuer of the credit card.
- 5.2.4. Cryptocurrency payments are accepted via our payment processor (Stripe), as indicated at checkout. You must pay for the entire balance owed including the Purchase Price and any other relevant charges entirely in one form of Cryptocurrency and you should ensure you have a sufficient balance to pay for all sums owed. We do not accept partial payment by Cryptocurrency and a different form of payment in one transaction. Cryptocurrency payment is only acceptable on the express understanding that the Lot is not returnable, refundable nor exchangeable. We also reserve the right to exclude the use of payment by Cryptocurrency on certain Lots, such exclusion to be noted on the listing.

5.2.5. [†] These lots are sold under standard VAT rules. For buyers within the UK and Northern Ireland, 20% VAT will be due on the hammer price; 20% VAT will also be due on the Buyer's premium. When lots are exported outside the UK and Northern Ireland (proof of export required or shipped by Propstore or through Propstore's authorised shipper), no VAT will be due on the hammer price; 20% VAT will be due on the Buyer's premium only ; unless items are exported to a registered business outside the UK and Northern Ireland, in which case no VAT is due.

5.2.6. [¶] These lots have been temporarily imported from outside the UK and Northern Ireland for sale at auction in London. For buyers within the UK and Northern Ireland (private individuals or registered businesses), 5% VAT will be due on the hammer price; 20% VAT will also be due on the Buyer's premium. When lots are exported outside

the UK and Northern Ireland (proof of export required or shipped by Propstore or through Propstore's authorised shipper), no VAT will be due.

5.2.7. [M] These lots are sold under the margin scheme. For buyers within the UK (private individuals or registered businesses), no VAT will be due on the hammer price; 20% VAT will be due on the Buyer's premium. When lots are exported outside the UK and Northern Ireland (proof of export required or shipped by Propstore or through Propstore's authorised shipper), no VAT is due. For Buyers in Northern Ireland, 20% VAT will be due on the Hammer Price.

5.2.8. [US] These lots are currently located in Propstore's Los Angeles facility and will ship directly to the buyer from the Los Angeles facility. For buyers within the UK and Northern Ireland (private individuals or registered businesses), no VAT will be charged by Propstore on the hammer price; 20% VAT will be due on the Buyer's premium. For buyers outside the UK and Northern Ireland, no VAT will be charged by Propstore.

5.2.9. [AR] On certain Lots marked "AR" in the catalogue an Additional Premium will be payable by the Buyer for royalties relating to the Artists Resale Right Regulations 2006. It does not apply on art with a hammer price under €1,000. The current breakdown is as follows:

Hammer Price:
 - From €0 to €50,000 - 4%
 - From €50,000.01 to €200,000 - 3%
 - From €200,000.01 to €350,000 - 1%
 - From €350,000.01 to €500,000 - 0.5%
 - Exceeding €500,000 - 0.25%

Resale royalties are not subject to VAT. Customers will be charged in GB£, however the € currency conversion rate from date of the sale is used.

5.2.10. Successful bidders whose total invoice is equal to or greater than €10,000 (or the GBP equivalent) shall agree to undergo Enhanced Customer Due Diligence (EDD) checks as per the EU Fifth Money Laundering Directive (5MLD). The lots won will not be released until the EDD check has been completed and passed.

5.2.11. Due to the impact of the U.S. Wayfair ruling Propstore is obligated to collect sales tax on orders shipped to a number of States within the U.S., even when auctioning from London. Additional States become sales tax-eligible regularly due to ongoing updates. Please review the online terms for the current list of States Propstore charges sales tax to - a state-by-state guide to taxes is provided below though this is subject to change; final taxes will be added to your invoice upon checkout.

Arizona	11.2%
California	9.50%
Florida	8.00%
Illinois	11.00%
Indiana	7.00%
Louisiana	11.50%
Maryland	6.00%
Massachusetts	6.30%
Michigan	6.00%

Nevada	8.30%
New York	8.80%
North Carolina	7.50%
Ohio	8.00%
Tennessee	10.00%
Texas	8.30%
Utah	8.70%
Virginia	7.00%
Washington	10.10%

Propstore charges sales tax in accordance with the individual state requirements; therefore additional states may become taxable for purchases from Propstore at any time. Buyers are encouraged to check with Propstore prior to bidding if they have questions about the sales tax status of potential purchases.

5.3. Export and Import

5.3.1. It is the Buyer's sole responsibility to arrange and obtain all necessary export/import licences, permits and any other necessary consents before the Lot is shipped.

5.3.2. Propstore's third-party independent recommended freight agent will be able to deal with enquiries from Bidders and Buyers on importing and/or exporting of Lots. Precision Cargo is Propstore's freight agent of choice.

5.3.3. With regards to lots exported outside the UK and Northern Ireland, if your Lots are shipped by Propstore or through Propstore's authorised shipper, you will not be required to pay VAT when settling your invoice. If you are using any other shipper, or hand carrying your Lots outside the UK and Northern Ireland, then VAT will be due on the invoice, which will be refunded once acceptable proof of export is provided by your shipper of choice.

5.3.4. To prove export of your Lots, on Ω Lots, obtain HMRC form C88 through Propstore's authorised shipper, which must be stamped by HMRC upon leaving the U.K.. On † or margin scheme Lots, obtain Notice 4 07 from Propstore's authorised shipper, which must be stamped by HMRC upon leaving the U.K.. In all cases Lots must be exported within no more than 3 months of the sale date, and proof of export must be reported via the appropriate form.

5.4. Shipping and storage

5.4.1. The Buyer is solely responsible for all shipping and delivery costs. Propstore recommends Lots are custom-packed and recommends FedEx as its carrier of choice. For oversized Lots, Propstore recommends Precision Cargo.

5.4.2. In the event of delay in shipping or failure to collect a Lot (for a reason outside Propstore's control) within 14 days of the due date for payment of Propstore's invoice (or such other date for shipping or collection agreed by Propstore a storage fee of 3% of the Hammer Price per month shall be charged to the Buyer. If the Buyer has failed to pay the Purchase Price and the cost of shipping and handling, Propstore, at its option may cancel the sale.

Terms & Conditions

These Terms and Conditions of Sale ("Conditions") set out the legal relationship between the Bidder/Buyer and Propstore and the Seller. By registering to bid and participate in a Propstore Auction, you will be deemed to have read and agreed to be bound by these Conditions and the accompanying Buyer's Guide, as set forth in the catalogue for the Auction and online at propstore.com.

1. Interpretation

These Conditions shall include the terms set out in the Propstore Live Auction Buyer's Guide, a copy of which has been made available to the Bidder. In the event of any conflict between these Conditions and the Buyer's Guide, these Conditions shall take precedence.

2. Definitions

2.1. See 2.1 of Buyer's Guide

3. Propstore as agent

3.1. Unless expressly agreed otherwise, Propstore acts as agent for the Seller. The contract for the sale of the Lot is made between the Seller and the Buyer.

3.2. Propstore's staff are not professional restorers so descriptions of Lots, images and statements of condition in Propstore's catalogue or on its website are for illustrative purposes only. Propstore cannot guarantee that colors are properly shown. Save for Propstore's Terms of Guarantee of Attribution, all Lots are sold "as is". Bidders are encouraged to inspect Lots and satisfy themselves as to their condition before bidding, seeking and obtaining independent professional advice where required.

3.3. Condition reports are available for each Lot upon request.

4. Catalogue descriptions and condition of Lots

4.1. All Lots are sold subject to their condition at the date of the Auction. The nature and age of the Lots means they are often unique and are likely to have wear and tear, damage and other imperfections and may have been totally or partially restored or repaired. By making a bid, the Bidder accepts the actual condition of the Lot and acknowledges that if a bid is successful, the Buyer will buy the Lot 'as is'.

4.2. Propstore's staff are not professional restorers so descriptions of Lots, images and statements of condition in Propstore's brochure or on its website are for illustrative purposes only. Poster lots in the auction may have undergone restoration; Propstore staff will make reasonable efforts to identify any restoration and this will be disclosed within the lot description. Propstore cannot guarantee that colours are properly shown. Save for Propstore Terms of Guarantee of Attribution all Lots are sold 'as is'. Save for Propstore Terms of Guarantee of Attribution all Lots are sold 'as is'. Propstore cannot and does not warranty any restoration the longevity of any restoration work carried out at any point in a lot's lifetime. Bidders are encouraged to inspect Lots and satisfying themselves as to condition before bidding, taking independent professional advice where required.

4.3. Condition reports are available for each lot upon request.

4.4. Film posters in the sale include condition abbreviations: M = mint; EX = excellent; VG = very good; G = good; F = fair.

4.5. Lots are sold only as collectibles and unless stated expressly to the contrary, Propstore makes no representation or warranty that any Lot is fit for any other purpose

4.6. Mannequins, display stands, scale measures and other display equipment are not included with the Lots unless expressly stated in the Lot description in the catalogue.

4.7. Estimates are simply a guide and should not be relied upon as to advice on value or the ultimate Purchase Price, which could be significantly higher.

5. 5. Before the Auction

5.1. Every Bidder must register with Propstore (including providing evidence of identity) in accordance with the Buyer's Guide. Personal information shall be used only in accordance with Condition 8 below.

5.2. From time to time, Propstore may offer a Lot which it owns in whole or in part or in which it has a financial interest and any such Lot will be identified in the catalogue with the symbol Δ next to its Lot number.

5.3. Bidders are aware that, due to the one-of-a-kind nature of the materials, Propstore only guarantees the provenance of Lots to the extent set out in the Terms of Guarantee of Attribution, and Propstore will not accept returns of any material and will not issue refunds, credits or exchanges except as provided for in the Guarantee of Attribution.

5.4. As a courtesy to Buyers, Propstore offers interest free payment plans on all auction invoices with a value of more than £1,000 (see Condition 7.3 of the Conditions of Sale). Note that you cannot use the payment plan if you wish to use Cryptocurrency as payment.

6. At the Auction

6.1. Propstore reserves the right to:

6.1.1. refuse admission and/or participation at the Auction and to reject any bid. Bids may not be accepted from unregistered bidders and all Bidders must be 18 or over;

6.1.2. apply a bidding cap or suspend bidding privileges to individual bidders at any point during the auction period. The cap will be withdrawn once evidence has been submitted to Propstore's satisfaction that all bids are genuine, the bidder has the means to complete the purchase(s) and any other security checks Propstore may be obliged to carry out have been completed.

6.2. All bids must be made in GBP Sterling. The auctioneer has the right to exercise reasonable discretion in refusing any bid, advancing the bidding in such a manner as he may decide, withdrawing or dividing any Lot, combining any two or more Lots and, in the case of error or dispute, and whether during or after the sale, determining the successful Bidder, continuing the bidding, cancelling the sale or reoffering and reselling the Lot in dispute. If any dispute arises after the sale, then, in the absence of any evidence to the contrary the sale record maintained by the auctioneer will be conclusive.

6.3. Unless otherwise indicated, all Lots are offered subject to a Reserve Price. The Reserve Price will not exceed the low estimate printed in the catalogue. The Reserve Price will not be more than the lowest estimate given by Propstore. Propstore may disclose or keep confidential the Reserve Price at its entire discretion.

6.4. The auctioneer may open the bidding on any Lot below the Reserve Price by placing a bid on behalf of the Seller. The auctioneer may continue to bid on behalf of the Seller up to the amount of the Reserve Price, either by placing consecutive bids or by placing bids in response to other Bidders.

6.5. When making a bid, every Bidder acknowledges that such bid is a binding offer to buy the Lot at that price (plus the Buyer's Premium, Buyer's Expenses (if applicable), all applicable taxes and any and all shipping charges, storage and other costs). A successful Bidder will be deemed to be the Buyer unless it has been explicitly agreed in writing with Propstore before the start of the Auction that the Bidder is acting as agent on behalf of an identified third party acceptable to Propstore (and registered with Propstore), and only then will Propstore regard that third party as the Buyer. In such circumstances, the Bidder acting as agent confirms that he is authorised to bind the third party and that the Buyer has been made aware of and accepts these Conditions.

Terms & Conditions

6.6. Propstore will use reasonable efforts to execute written bids delivered before the Auction for Bidders unable to attend the auction in person, by an agent or by telephone or online. All such written bids must be made on Propstore's Absentee Bids Form (in the catalogue).

6.7. If Propstore receives written bids on a particular Lot for identical amounts, and at the auction these are the highest bids on the Lot, it will be sold to the person whose written bid was received and accepted first.

6.8. Online bidding at Propstore Auctions is made available via third party service providers and use of their services and all online bidding is subject to their respective terms of use. Successful online bids will be subject to payment of Buyer's Expenses.

6.9. The Auction will be tracked on a video or digital screen, which may display, among other things, a photograph of the Lot offered for sale and the then-current bid. Bidders understand and agree that errors may occur in its operation and, except as expressly stated in the Buyer's Guide or these Conditions, Propstore shall have no liability arising out of or related to any errors or omission in respect thereto.

6.10. By participating in and/or attending the Auction and signing the registration form, each person consents to be filmed and/or photographed and agrees and authorises Propstore to use and publish such film and/or photographs, name and likeness for use in (1) providing online access to the Auction, (2) recording the results of the Auction, (3) print, digital, online and all other media for marketing purposes (including without limitation, on Propstore's website, YouTube and other online platforms) and (4) in any other Propstore publications of whatever nature. The participant releases Propstore and holds it harmless from any reasonable expectation of confidentiality or privacy associated with such images and releases Propstore and any third parties involved in the making, creation or publication of the images or any marketing or other materials from all and any liability for claims made in respect of such publication. Publication of the images in whatever format confers no right of ownership on the individual or right to royalties or payment. A designated area will be set aside if you do not wish to be filmed. If you wish to withdraw consent, email support@propstore.com.

6.11. Subject to the auctioneer's reasonable discretion, the Bidder placing the highest bid accepted by the auctioneer will be the Buyer and the striking of his hammer marks the acceptance of the highest bid and the conclusion of a contract for sale between the Seller and the Buyer. Risk and responsibility for the Lot (including frames or glass where relevant) passes to the Buyer on the date seven calendar days from the date of the sale or on collection by the Buyer if earlier and the Buyer should arrange insurance cover for the Lot if required.

7. 7. After the Auction

7.1. Propstore will notify successful Bidders and send (by email unless requested otherwise) a payment invoice setting out the Purchase Price and itemising the Hammer Price and Buyer's Premium plus any applicable VAT within 7 calendar days of the end of the Auction.

7.2. Unless a payment plan (as set out in condition 7.3 below) has been agreed by Propstore, payment is due within 7 calendar days from receipt of invoice and must be made by the Buyer. Payments from any other source will not be accepted and shall be returned by Propstore.

7.3. Payment plans will be available in 1, 2, or 3 month increments on any invoice over £1000, unless otherwise specified on the individual lot. Bidders wishing to utilise the payment plan service, if approved by Propstore, will be responsible for paying a 20% deposit on their Lots within 7 calendar days of receiving their invoice. The balance will then be split over 1, 2 or 3 months per the Buyer's selection. If the 1 month option is selected, the remaining balance on the Lot will be due 30 days after the deposit date. If the 2 month option is selected, half of the remaining balance will be due 30 days after the deposit date and the remaining half 30 days after that, and so on.

7.4. Propstore offers no grace period on payment plan deadlines. If the Buyer does not adhere to payment deadline as agreed under the terms of the payment plan, the Buyer will have defaulted. In the event of default all funds already paid to Propstore will be forfeited by the Buyer, and title of the Lot will not transfer to Buyer. Propstore and the Seller shall also be entitled to all remedies for non-payment as described below and at law.

7.5. Title in the Lot will pass to Buyer and the Lot will be made available for collection by the Buyer only when Propstore is completely satisfied that all monies owing have been paid in full.

7.6. Payment must be in Pounds Sterling and may be made by electronic transfer, debit card, credit card (up to a maximum of £25,000) bankers draft or cash (up to a maximum of £5,000). Please quote the Lot number, invoice number and Bidder registration number when making payment to ensure it can be processed as efficiently as possible.

7.7. Credit card payments are only acceptable on the express understanding that the Lot is not returnable, refundable nor exchangeable and no charge card credit or refund may be issued in the event of any such return. If payment is made by credit card, Buyer will not undertake any action or effort to stop payment, seek a refund, or attempt a charge back of such amounts – or any Credit Card Fee assessed thereon – by the issuer of the credit card.

7.8. Cryptocurrency payments are accepted via our payment processor (Bitpay), as indicated at checkout. You must pay for the entire balance owed including the Purchase Price and any other relevant charges entirely in one form of Cryptocurrency and you should ensure you have a sufficient balance to pay for all sums owed. We do not accept partial payment by Cryptocurrency and a different form of payment in one transaction. Cryptocurrency payment is only acceptable on the express understanding that the Lot is not returnable, refundable nor exchangeable. We also reserve the right to exclude the use of payment by Cryptocurrency on certain Lots, such exclusion to be noted on the listing.

7.9.

[H] These lots are sold under standard VAT rules. For buyers within the UK and Northern Ireland, 20% VAT will be due on the hammer price; 20% VAT will also be due on the Buyer's premium. When lots are exported outside the UK and Northern Ireland (proof of export required or shipped by Propstore or through Propstore's authorised shipper), no VAT will be due on the hammer price; 20% VAT will be due on the Buyer's premium only; unless items are exported to a registered business outside the UK and Northern Ireland, in which case no VAT is due.

[O] These lots have been temporarily imported from outside the UK and Northern Ireland for sale at auction in London. For buyers within the UK and Northern Ireland (private individuals or registered businesses), 5% VAT will be due on the hammer price; 20% VAT will also be due on the Buyer's premium. When lots are exported outside the UK and Northern Ireland (proof of export required or shipped by Propstore or through Propstore's authorised shipper), no VAT will be due.

[M] These lots are sold under the margin scheme. For buyers within the UK (private individuals or registered businesses), no VAT will be due on the hammer price; 20% VAT will be due on the Buyer's premium. When lots are exported outside the UK (proof of export required or shipped by Propstore or through Propstore's authorised shipper), no VAT is due. For buyers within Northern Ireland, 20% VAT will be due on the Hammer Price.

[US] These lots are currently located in Propstore's Los Angeles facility and will ship directly to the buyer from the Los Angeles facility. For buyers within the UK and Northern Ireland (private individuals or registered businesses), no VAT will be charged by Propstore on the hammer price; 20% VAT will be due on the Buyer's premium. For buyers outside the UK and Northern Ireland, no VAT will be charged by Propstore.

[AR] Artist's Resale Right – On certain Lots marked "AR" in the catalogue an Additional Premium will be payable by the Buyer for royalties relating to the Artists Resale Right Regulations 2006. It does not apply on art with a hammer price under €1,000. The current breakdown is as follows:

Hammer Price

– From €0 to €50,000 – 4%

Terms & Conditions

– From €50,000.01 to €200,000 – 3%

– From €200,000.01 to €350,000 – 1%

– From €350,000.01 to €500,000 – 0.5%

– Exceeding €500,000 – 0.25%

Resale royalties are not subject to VAT. Customers will be charged in GBP, however the € currency conversion rate from date of the sale is used.

710. The Buyer will not acquire title to the Lot until all amounts due to the Seller and Propstore from the Buyer have been received by Propstore in cleared funds even in circumstances where Propstore has released the Lot to the Buyer.

711. By registering for this auction the Buyer authorises Propstore to charge the credit card provided at registration for all Lots purchased at the auction, and any future auction a Bidder may participate in, if not paid in full within 7 calendar days after the auction close.

712. If the Buyer does not make any payment due to Propstore by the due date for payment, Propstore may charge a fee on the overdue amount at the rate of 5% a year above the base lending rate of Lloyds Bank plc from time to time. This fee shall accrue on a daily basis from the due date until the date of actual payment of the overdue amount, whether before or after judgment. The Buyer must pay Propstore fee together with any overdue amount.

713. In addition to its rights in condition 711 and at law, in the event of default by the Buyer, Propstore may take one or more of the following actions:

713.1. hold the Buyer liable for the total amount due and commence legal proceedings for its recovery together with interest, legal fees and costs to the fullest extent permitted under applicable law;

713.2. cancel the sale;

713.3. resell the Lot publicly or privately on such terms as Propstore shall think fit;

713.4. pay the Seller an amount up to the net proceeds payable in respect of the Hammer Price;

713.5. set off against any amounts which Propstore may owe to the Buyer in any other transactions, some or all of the outstanding amount remaining unpaid by the Buyer;

713.6. apply any amount paid to discharge any amount owed in respect of any particular transaction, whether or not the Buyer so directs;

713.7. reject at any future auction any bids made by or on behalf of the Buyer or to require a deposit from the Buyer before accepting any further bids;

713.8. exercise all the rights and remedies of a person holding security over any Lot in Propstore's possession owned by the Buyer, whether by way of pledge, security interest or in any other way, to the fullest extent permitted by the law of the place where such Lot is located. The Buyer will be deemed to have granted such security to Propstore and it may retain such Lot as collateral security for such Buyer's obligations;

713.9. take such other action as Propstore deems necessary or appropriate. If Propstore resells the Lot under condition 713.3 above, the Buyer shall be liable for payment of any deficiency between the total amount originally due to Propstore and the amount received upon resale as well as all reasonable costs, expenses, damages, legal fees and commissions and premiums of whatever kind associated with both sales or otherwise arising from the default. If Propstore pays any amount to the Seller under condition 713.4 above, the Buyer acknowledges that Propstore shall have all of the rights of the Seller, however arising, to pursue the Buyer for such amount.

714. Propstore shall be entitled to retain Lots sold until all amounts due have been received in full in good cleared funds or until the Buyer has performed any other outstanding obligations as Propstore shall reasonably require. Subject to this, the Buyer shall collect, or have shipped or collected for shipment, purchased Lots within 7 calendar days from the date of the sale unless otherwise agreed between Propstore and the Buyer. Lots can be collected in person by appointment only.

715. Each Lot will require a custom packing service and by bidding on a Lot a Bidder agrees to pay all relevant shipping costs. Propstore's carrier of choice is FedEx, although some Lots will require special freight service. Potential shipping estimates can be obtained by emailing shipping@propstore.com detailing the Lot number of interest and the shipping address prior to the auction.

716. Propstore recommends working with its preferred third-party independent freight agent Precision Cargo on any questions regarding importing and exporting Lots.

717. Although Propstore shall use reasonable efforts to take care when selecting third parties for these purposes, the Buyer will contract directly with such third party and Propstore accepts no liability or responsibility for the acts or omissions of any such third parties. Similarly, where Propstore suggests other handlers, packers or carriers, its suggestions are made on the basis of its general experience of such parties in the past and Propstore is not responsible to any person to whom it has made a recommendation for the acts or omissions of the third party concerned.

718. It is the Buyer's sole obligation and responsibility to be aware of, to comply with, and to pay for all relevant import duties, taxes, VAT, customs and other fees charged in the Buyer's local jurisdiction. Propstore will ship all packages with the full value of the Lot declared. Buyer understands and agrees that Propstore shall have no obligation or responsibility for any import duties, taxes, VAT, customs, shipping or other charges for the Lots shipped. Failure by the Buyer to pay all necessary amounts may result in the relevant authorities returning the Lot to Propstore and in those circumstances the Buyer will be charged and will pay storage cost and Propstore's additional reasonable costs and expenses.

719. It is the Buyer's responsibility to ensure that any Lot purchased from Propstore enters the shipping location lawfully, that all duties and taxes have been paid and that all required export procedures, regulations, and laws were properly complied with. Buyer understands and agrees that Propstore shall have no obligation or responsibility for complying with any export procedures, regulations, or laws applicable to the Lot.

720. Unless otherwise agreed by Propstore in writing, the fact that the Buyer wishes to apply for an export licence does not affect or postpone the Buyer's obligation to make payment in accordance with Propstore's payment terms nor Propstore's right to charge fees or storage charges on late payment. If the Buyer requests Propstore to apply for an export licence on his or her behalf, Propstore shall be entitled to make a charge and be paid for this service. Propstore shall not be obliged to rescind or cancel a sale nor to refund any monies paid by the Buyer to Propstore as a result of or related to the Buyer's failure or inability to obtain an export licence.

721. Where Lots are not collected within 14 calendar days from the due date of payment, whether or not payment has been made, a storage fee of 3% of the Hammer Price per month shall be charged to the Buyer. If the Buyer has failed to pay the Purchase Price and the cost of shipping and handling, Propstore, at its option may cancel the sale.

722. Successful bidders whose total invoice is equal to or greater than €10,000 (or the GBP equivalent) shall agree to undergo Enhanced Customer Due Diligence (EDD) checks as per the EU Fifth Money Laundering Directive (5MLD). The lots won will not be released until the EDD check has been completed and passed.

723. Due to the impact of the U.S. Wayfair ruling Propstore is obligated to collect sales tax on orders shipped to a number of States within the U.S., even when auctioning from London. Additional States become sales tax-eligible regularly due to ongoing updates. Please review the online terms for the current list of States Propstore charges sales tax to; final taxes will be added to your invoice upon checkout.

Terms & Conditions

8. Use of information

- 8.1. Propstore will hold all personal information provided by the Bidder at registration and the Bidder agrees and consents to such information being used by Propstore to:
- 8.1.1. make available each Lot for shipping to the Buyer;
 - 8.1.2. process the Buyer's payment and use the registered email address to update the buyer about their order, including but not limited to sending reminders relating to any outstanding payment;
 - 8.1.3. contact credit reference agencies and keep records of any searches carried out on Propstore's behalf;
 - 8.1.4. where explicit consent has been given, inform the Bidder about upcoming auctions and news (please contact Propstore by email at support@propstore.com or by phone +44 (0)1494 766485 if you wish to stop receiving these);
 - 8.1.5. inform the Bidder about important auction updates; this personal information including email addresses will be deleted from the auction mailing list once the auction is complete
 - 8.1.6. In the event of non-payment, we can, at our option, reveal your identity and contact details to the seller

9. Liability

- 9.1. If Propstore fails to comply with these Conditions it is responsible for loss or damage a Buyer suffers that is a foreseeable result of Propstore's breach or its negligence. Propstore is not responsible for any loss or damage that is not foreseeable. Loss or damage is foreseeable if an obvious consequence of Propstore's breach or if contemplated by the Buyer and Propstore at the time the hammer falls on the Lot at the Auction.
- 9.2. Subject to condition 9.3, Propstore's liability shall be limited to the amount actually paid for the Lot by the Buyer. Save to the extent required by law, in no event shall Propstore be liable for incidental or consequential damages of any kind.
- 9.3. 9.3. Propstore does not exclude or limit its liability for:
- 5.4.3. death or personal liability caused by its negligence or the negligence of its employees, agents or subcontractors;
 - 5.4.4. fraud or fraudulent misrepresentation; and
 - 5.4.5. breach of the terms implied by sections 12, 13, 14 and 15 of the Sale of Goods Act 1979 (title, description, quality and fitness for purpose) save to the fullest extent permissible at law.

10. Terms of Guarantee of Attribution

- 10.1. Propstore warrants the attribution of each Lot as stated in the title block (film title and item title) of that Lot in the Auction catalogue, subject to any revisions (which may be given in writing or online before or during the Auction at which the Lot is purchased by the Buyer); this is Propstore's Guarantee of Attribution. Buyers should be aware that multiple examples of props and costumes are frequently used during production and it is often impossible to determine whether a specific piece has been used on-camera. Any specific on-camera usage known to Propstore will be noted within the description, but no warranties are given by Propstore on that description.
- 10.2. If a Buyer demonstrates, to Propstore's reasonable satisfaction, that the Guarantee of Attribution is materially incorrect, the sale will be rescinded if the Lot is returned to Propstore in the same condition in which it was at the time of sale. In order to satisfy Propstore that the Guarantee of Attribution is materially incorrect, Propstore reserves the right to require the Buyer to obtain, at the Buyer's expense, the opinion of two experts in the field, mutually acceptable to Propstore and the Buyer.
- 10.3. In the event a sale is rescinded in accordance with condition 10.2, Propstore shall repay to the Buyer the Purchase Price. Repayment of the Purchase Price shall be the Buyer's sole remedy for an incorrect Guarantee of Attribution, to the exclusion of all other remedies to the extent permissible at law. It is specifically understood that this will be considered the Buyer's sole remedy under this clause 10.
- 10.4. The Buyer expressly agrees that Propstore shall not be liable in whole or in part, for, and the Buyer shall not be entitled to recover, any special, indirect, incidental or consequential damages including loss of profits or value of investment or opportunity cost.
- 10.5. Bidders are aware that description revisions may occur on some Lots, and should inquire before the Auction whether any description revisions have occurred on a given Lot and/or examine a lot before bidding on it. Propstore will make all reasonable efforts to make description revisions readily available during the Auction.
- 10.6. Except as expressly provided in these Conditions Propstore shall have no liability to the Buyer in respect of a Lot and all and any implied warranties and conditions are excluded to the fullest extent permitted by law.

11. Intellectual property rights

- 11.1. The copyright in all images, illustrations and written material produced by or for Propstore relating to a Lot (including the contents of the Auction catalogue), is and shall remain at all times the property of Propstore and shall not be used by the Buyer, nor by anyone else, without Propstore's written consent. Propstore and the Seller make no representation or warranty that the Buyer of a Lot will acquire any copyright or other reproduction rights in it.
- 11.2. In the catalogue descriptions, Propstore takes steps to identify and provide provenance for Lots offered at auction. In many cases, the Lots offered were used in or in conjunction with motion pictures or other programmes and information is furnished in order to fully identify and describe the Lot offered at Auction, including photographs and illustrations. Propstore in no way claims any connection to or relationship with the producers of the motion picture or other programme. In all cases, the use of the titles or other elements of a motion picture or other programme is for informational purposes only.

12. Events outside our control

Propstore will not be liable or responsible for any failure to perform, or delay in performance of, any of its obligations under these Conditions that is caused by an event outside its control, that being any act or event beyond Propstore's reasonable control, including without limitation strikes, lock-outs or other industrial action by third parties, civil commotion, riot, invasion, terrorist attack or threat of terrorist attack, war (whether declared or not) or threat or preparation for war, fire, explosion, storm, flood, earthquake, subsidence, epidemic or other natural disaster, or failure of public or private telecommunications networks. Propstore's obligations shall be suspended and time for performance extended until such time as the event outside its control is over, following which a new collection or shipping date can be agreed.

13. Other important terms

- 13.1. If any part of these Conditions is found by any court to be invalid, illegal or unenforceable, that part shall be discounted and the rest of the Conditions shall continue to be valid to the fullest extent permitted by law.
- 13.2. The contract is between the Seller, Buyer and Propstore and no other person shall have any rights to enforce any of its terms.

Terms & Conditions

13.3. If Propstore fails to insist on performance of any of a Buyer's obligations under these Conditions, or if it delays in doing so, that will not mean that Propstore has waived its rights against the Buyer and does not mean the Buyer no longer has to comply with those obligations.

13.4. These Conditions are governed by English law, without regard to its choice of law provisions. The Parties agree that any dispute or claim (including non-contractual disputes or claims) arising out of or in connection with this agreement or its subject matter or formation may be brought in any court of competent jurisdiction located in England or Wales or, alternatively, in any court of competent jurisdiction where Propstore or the Bidder/Buyer resides, at the option of the Party bringing the claim, only. The Parties expressly agree to the jurisdiction of such courts and agree to submit to the jurisdiction of such courts. The prevailing party shall be entitled to an award of all Lawyers' fees, costs and expenses incurred by it/him/her in connection with the dispute. "Lawyers' fees and expenses" includes, without limitation, paralegals' fees and expenses, solicitor's fees consultants' fees and expenses, expert witness' fees and expenses, and all other expenses incurred by the prevailing party or its attorneys in the course of their representation of the prevailing party in anticipation of and/or during the course of the litigation, whether or not otherwise recoverable as "attorneys' fees" or as "costs" under applicable law; and the same may be sought and awarded in accordance with applicable procedure as pertaining to an award of contractual Lawyers' fees.

13.5. By registering for this auction, the supplied card will automatically have a sum of £0.01 held and subsequently returned within 30 working days to verify the validity of the card.

13.6. By purchasing an item in our auction, you acknowledge that due to the unique nature of the assets offered for sale and the careful process undertaken to prepare the items for dispatch, the default consumer rights to receive your goods within 30 days are waived.

13.7. The buyer is solely responsible for ascertaining that each lot sold with copyright is otherwise cleared for publication including but not limited to satisfying any publicity right that persons appearing in an image may have under any statute or common law. Neither the consignor nor Propstore Ltd makes any representation or warranty as to any matters that need to be cleared prior to publication. No representation or warranty is made regarding copyright outside of the United Kingdom. All publication issues should be referred to the buyer's own professional advisors. All representations or warranties as to copyright or rights to publish are solely made by the consignor and not Propstore Ltd; the buyer agrees that Propstore Ltd. will not be liable to Buyer in any respect for alleged breach of any such representation or warrant.

Sales Tax Quick Reference Guide

Arizona	11.2%
California	9.50%
Florida	8.00%
Illinois	11.00%
Indiana	7.00%
Louisiana	11.50%
Maryland	6.00%
Massachusetts	6.30%
Michigan	6.00%

Nevada	8.30%
New York	8.80%
North Carolina	7.50%
Ohio	8.00%
Tennessee	10.00%
Texas	8.30%
Utah	8.70%
Virginia	7.00%
Washington	10.10%

Propstore charges sales tax in accordance with the individual state requirements; therefore additional states may become taxable for purchases from Propstore at any time. Buyers are encouraged to check with Propstore prior to bidding if they have questions about the sales tax status of potential purchases.



If you are a television or film prop collector,

Protect your investment!

Bespoke display cases designed and manufactured to the specification and size you require. Call us today for a free, no obligation quotation.

www.aboutpresentation.com

01425 652373

info@aboutpresentation.com

SAS specialauctionservices.com

With over 30 years auctioneering experience, we advise our clients with confidence!!
 Valuations undertaken for Auctions, Inheritance Tax, Open Market and Insurance Purposes

Please call us to discuss your collection on 01635 580595 or email us, mail@specialauctionservices.com

Meet your Prop Store Auctioneers, Thomas, Jessica & Neil

Precision

cargo services limited

OFFICIAL PARTNER

- Airfreight – Door-to-Door & Airport-to-Airport worldwide
- International Express Courier
- Ocean Freight Services
- European Road Freight
- Aircraft Charters
- Import & Export Customs Procedures
- ATA Carnet Advice & Completion
- Domestic Overnight Services
- Dangerous Goods Advice, Packing &
- Shipping Including Explosives
- BBC & ITV Approved Contractor
- Netflix Approved Vendor
- Home Office Approved Section 5 & 1 for the Movement of Weaponry
- Storage & Packing

Pinewood Office: 01753 650551 | Shepperton Office: 01932 593377
 Felxstowe Office: 01394 613 113 & LAX Office: 310 410 0100
 www.precisioncargo.co.uk bookings@precisioncargo.co.uk

DAY 01	LOTS 1 – 448 PG. 7 - 387 NOV 3, 2022 THURS. 3:00 PM (GMT) 8:00 AM (PDT)	DAY 02	LOTS 449 – 623 PG. 7 - 133 NOV 4, 2022 FRI. 3:00 PM (GMT) 8:00 AM (PDT)	DAY 03	LOTS 624 – 1083 PG. 390 - 531 NOV 5, 2022 SAT. 3:00 PM (GMT) 8:00 AM (PDT)	DAY 04	LOTS 1084 – 1536 PG.532 - 670 NOV 6, 2022 SUN. 3:00 PM (GMT) 7:00 AM (PST)
---------------	--	---------------	--	---------------	---	---------------	---

See separate catalog containing Music Lots

Index

Film or Show	Page Number(s)	Film or Show	Page Number(s)
#		D	
2001: A SPACE ODYSSEY (1968)	7-10, 391	CABIN IN THE WOODS, THE (2011)	435
24 (TV. SERIES, 2001 - 2010)	391	CAPTAIN AMERICA: THE FIRST AVENGER (2011)	87
28 WEEKS LATER (2007)	392	CARLITO'S WAY (1993)	87
3:10 TO YUMA (2007)	10	CAST AWAY (2000)	88-90, 435-437
300 (2006)	11, 392	CHAPLIN (1992)	437
48 HRS (1982)	12	CHARLIE AND THE CHOCOLATE FACTORY (2005)	438-439
6TH DAY, THE (2000)	393	CHARLIE'S ANGELS (2000)	440
8 MILE (2002)	12	CHILDREN OF THE CORN (1984)	440
A		CHILD'S PLAY 2 (1990)	91, 440
A.I. ARTIFICIAL INTELLIGENCE (2001)	393	CHITTY CHITTY BANG BANG (1968)	92
ADJUSTMENT BUREAU, THE (2011)	12-13, 393-394	CHRISTINE (1983)	441
ALIAS (TV. SERIES, 2001 - 2006)	394	CHRISTMAS STORY, A (1983)	439
ALIEN (1979)	13-16, 396-397	CHRONICLES OF NARNIA, THE: LION, THE WITCH AND THE WARDROBE, THE (2005)	441
ALIEN 3 (1992)	22-23, 406-407	CHRONICLES OF NARNIA, THE: PRINCE CASPIAN (2008)	93
ALIENS (1986)	16-38, 397-406	CHRONICLES OF NARNIA, THE: VOYAGE OF THE DAWN TREADER, THE (2010)	442-443
AMERICAN GODS (TV. SERIES, 2017 - 2021)	408	CHRONICLES OF RIDDICK, THE (2004)	443
AMERICAN PSYCHO (2002)	38-39	CLASH OF THE TITANS (1981)	443-444
AMERICAN WEREWOLF IN LONDON, AN (1981)	39-40	CLASH OF THE TITANS (2010)	444
ANNIE (1982)	408	CLIVE BARKER'S BOOK OF BLOOD (2009)	444
ARGO (2012)	409	CLOSE ENCOUNTERS OF THE THIRD KIND (1977)	93-95
ARMAGEDDON (1998)	40	COCOON (1985)	444
ARMY OF DARKNESS (1992)	407	COLD MOUNTAIN (2003)	445
ASH VS EVIL DEAD (TV. SERIES, 2015-2018)	41, 409	CONAN THE BARBARIAN (1982)	445-446
AUSTIN POWERS IN GOLDMEMBER (2002)	44, 412-413	CONAN THE DESTROYER (1984)	446
AUSTIN POWERS: INTERNATIONAL MAN OF MYSTERY (1997)	42-43, 410	CONTACT (1997)	446-448
AUSTIN POWERS: THE SPY WHO SHAGGED ME (1999)	43, 410-412	CROCODILE DUNDEE (1986)	449
AVENGERS, THE (1998)	414	CROW, THE (1994)	449-450
AVENGERS, THE (TV. SERIES, 1961 - 1969)	413	CRY-BABY (1990)	450
AVENGERS: AGE OF ULTRON (2015)	45-46	CSI: CRIME SCENE INVESTIGATION (TV. SERIES, 2000 - 2015)	546
B		D	
BACK TO THE FUTURE (1985)	47, 414-415	DAMIEN: OMEN II (1978)	565
BACK TO THE FUTURE PART II (1989)	47-51, 415-416	DARK CRYSTAL, THE (1982)	450-452
BACK TO THE FUTURE PART III (1990)	48-49, 52-55, 416	DARK KNIGHT, THE (2008)	65-66, 424-425
BAND OF BROTHERS (TV. SERIES, 2001)	416-417	DECK THE HALLS (2006)	452
BATMAN (1989)	55-58, 419-421	DEPARTED, THE (2006)	453-454
BATMAN (TV. SERIES, 1966 - 1968)	417-419	DEVIL'S BACKBONE, THE (2001)	96
BATMAN BEGINS (2005)	423, 425	DEVILS, THE (1971)	455
BATMAN FOREVER (1995)	63-65, 422-423	DEXTER (TV. SERIES, 2006 - 2013)	97
BATMAN RETURNS (1992)	58-62, 421-422	DIE HARD (1988)	98, 455
BATMAN, THE (2022)	67	DIE HARD WITH A VENGEANCE (1995)	98-99, 455
BATTLE OF BRITAIN (1969)	425-426	DISNEYLAND THEME PARK (1983)	456
BEAUTY AND THE BEAST (2017)	426	DIVERGENT (2014)	456
BEETLEJUICE (1988)	426	DIANGO UNCHAINED (2012)	456
BEN HUR (2016)	427	DOCTOR SLEEP (2019)	100, 457
BENEATH THE PLANET OF THE APES (1970)	569	DOCTOR STRANGE (2016)	100-101
BEVERLY HILLS CHIHUAHUA (2008)	427	DOCTOR WHO (TV. SERIES, 2005 - PRESENT)	102-105, 458-465
BEWITCHED (2005)	427	DOCTOR WHO: THE FIVE DOCTORS (1983)	458
BIG TROUBLE IN LITTLE CHINA (1986)	71	DOCTOR WHO: THE MOVIE (1996)	458
BLACK MASS (2015)	427	DR. STRANGELOVE OR: HOW I LEARNED TO STOP WORRYING AND LOVE THE BOMB (1964)	465
BLACKLIST, THE (TV. SERIES, 2013 - 2022)	428	DRAGONSLAYER (1981)	465
BLADE (1998)	68-69	E	
BLADE 2 (2002)	428	ET. ADVENTURE	106
BLADE RUNNER (1982)	72-73	EDGE OF TOMORROW (2014)	467-468
BLADE TRINITY (2004)	70	ELF (2003)	106-107, 468
BLAKE'S 7 (TV. SERIES, 1978 - 1981)	274, 428	ERAGON (2006)	469
BLUES BROTHERS, THE (1980)	428	ESCAPE FROM LA (1996)	108
BODYGUARD, THE (1992)	74-76, 429-431	ESCAPE FROM THE PLANET OF THE APES	571
BOOGIE NIGHTS (1997)	76	EVENT HORIZON (1997)	108
BORROWERS, THE (1998)	431	EVIL DEAD II (1987)	109-110
BOURNE SUPREMACY, THE (2004)	431	EVIL DEAD, THE (1981)	469
BOURNE ULTIMATUM, THE (2007)	77-78	EXCALIBUR (1981)	110-112
BRAINSTORM (1983)	432	EXISTENZ (1999)	470
BRAVEHEART (1995)	432	EXODUS: GODS AND KINGS (2014)	470
BREAKING BAD (TV. SERIES, 2008 - 2013)	78-79, 433- 434	EYES WIDE SHUT (1999)	470
BRUCE LEE	80-87	F	
BUCKET LIST, THE (2007)	435	FACE/OFF (1997)	471
C		FANTASTIC FOUR (2005)	471
		FARSCAPE (TV. SERIES, 1999 - 2003)	113

**DAY
01**

LOTS 1 – 448
PG. 7 – 387
NOV 3, 2022
THURS. 3:00 PM (GMT)
8:00 AM (PDT)

**DAY
02**

LOTS 449 – 623
PG. 7 – 133
NOV 4, 2022
FRI. 3:00 PM (GMT)
8:00 AM (PDT)

**DAY
03**

LOTS 624 – 1083
PG. 390 – 531
NOV 5, 2022
SAT. 3:00 PM (GMT)
8:00 AM (PDT)

**DAY
04**

LOTS 1084 – 1536
PG.532 – 670
NOV 6, 2022
SUN. 3:00 PM (GMT)
7:00 AM (PST)

See separate catalog containing Music Lots

Index

Film or Show	Page Number(s)
FAST AND THE FURIOUS, THE (2001)	472
FEW GOOD MEN, A (1992)	470
FIFTH ELEMENT, THE (1997)	113-116, 472-473
FIGHT CLUB (1999)	116-117, 473
FINDING NEVERLAND (2004)	117
FLASH GORDON (1980)	474-475
FLASH GORDON CONQUERS THE UNIVERSE (1940)	473
FLIGHT OF THE NAVIGATOR (1986)	475
FLINTSTONES, THE (1994)	475
FLUBBER (1997)	476
FLY, THE (1986)	476
FOREIGNER, THE (2017)	476
FORREST GUMP (1994)	476-478
FORTRESS (1992)	478
FRAGGLE ROCK (TV. SERIES, 1983 – 1987)	118-119
FRAGGLE ROCK: THE ANIMATED SERIES (TV. SERIES, 1987 – 1988)	478
FREDDY VS. JASON (2003)	128-133, 485
FREDDY'S NIGHTMARES (TV. SERIES, 1988 – 1990)	233
FRIDAY THE 13TH (2009)	485-486
FRIDAY THE 13TH PART III (1982)	479
FRIDAY THE 13TH PART VI: JASON LIVES (1986)	120-122, 479
FRIDAY THE 13TH PART VII: THE NEW BLOOD (1988)	480-483
FRIDAY THE 13TH PART VIII: JASON TAKES MANHATTAN (1989)	123-125
FROM DUSK TILL DAWN (1996)	134
FURY (2014)	486
G	
GAME OF THRONES (TV. SERIES, 2011 – 2019)	487-488
GENTLEMEN, THE (2019)	488-490
GHOSTBUSTERS (1984)	491
GHOSTBUSTERS II (1989)	134-135, 491
GLADIATOR (2000)	136-140, 492-495
GODFATHER PART III, THE (1990)	496
GOLDEN COMPASS, THE (2007)	496
GOODFELLAS (1990)	141
GORILLAS IN THE MIST (1988)	497
GRACE KELLY	497
GREAT MUPPET CAPER, THE (1981)	564
GREEN HORNET, THE (TV. SERIES, 1966 – 1967)	86
GREMLINS 2: THE NEW BATCH (1990)	141-143
GUARDIANS OF THE GALAXY (2014)	497
H	
HALLOWEEN (2007)	145, 498
HALLOWEEN H2O: 20 YEARS LATER (1998)	144
HALLOWEEN: RESURRECTION (2002)	145
HARRY POTTER AND THE CHAMBER OF SECRETS (2002)	501
HARRY POTTER AND THE GOBLET OF FIRE (2005)	156, 502
HARRY POTTER AND THE PHILOSOPHER'S STONE (2001)	146-154, 498-501
HARRY POTTER AND THE PRISONER OF AZKABAN (2004)	155, 502
HATEFUL EIGHT, THE (2015)	157-158
HELLBOUND: HELLRAISER II (1988)	502
HELLBOY (2004)	159-160
HELLRAISER (1987)	161-163, 502
HELLRAISER III: HELL ON EARTH (1992)	503
HELLRAISER VI: HELLSEEKER (2002)	164
HELLRAISER: REVELATIONS (2011)	503
HIGHLANDER (1986)	503-504
HIGHLANDER (TV. SERIES, 1992 – 1998)	505
HIGHLANDER II: THE QUICKENING (1991)	504
HILL, THE (1965)	505
HIS DARK MATERIALS (TV. SERIES, 2019 – PRESENT)	505
HOBBIT, THE: AN UNEXPECTED JOURNEY (2012)	505-506
HOBBIT, THE: THE BATTLE OF THE FIVE ARMIES (2014)	164
HOCUS FOCUS (1993)	506
HOME ALONE 2: LOST IN NEW YORK (1992)	507
HOOK (1991)	166-167, 507-508
HOW THE GRINCH STOLE CHRISTMAS (2000)	168-169, 509
HUNGER GAMES, THE (2012)	509

I

Film or Show	Page Number(s)
IF... (1968)	165
IN TIME (2011)	509
INCEPTION (2010)	170
INDEPENDENCE DAY (1996)	509
INDIANA JONES AND THE KINGDOM OF THE CRYSTAL SKULL (2008)	512
INDIANA JONES AND THE LAST CRUSADE (1989)	511
INDIANA JONES AND THE RAIDERS OF THE LOST ARK (1981)	172-173
INDIANA JONES AND THE TEMPLE OF DOOM (1984)	173
INDUSTRIAL LIGHT AND MAGIC (ILM)	611
INGLOURIOUS BASTERDS (2009)	171
INSOMNIA (2002)	512
INSPECTOR GADGET (1999)	512
INTERVIEW WITH THE VAMPIRE: THE VAMPIRE CHRONICLES (1994)	512-513
IT CHAPTER TWO (2019)	512-515
J	
JAMES AND THE GIANT PEACH (1996)	516
JAMES BOND COLLECTIBLES	174-175
JAMES BOND: A VIEW TO A KILL (1985)	184, 519-521
JAMES BOND: CASINO ROYALE (2006)	191-192, 529
JAMES BOND: DIAMONDS ARE FOREVER (1971)	177
JAMES BOND: DIE ANOTHER DAY (2002)	190, 527-529
JAMES BOND: DR. NO (1962)	176-177
JAMES BOND: GOLDENEYE (1995)	185-189, 524
JAMES BOND: GOLDFINGER (1964)	178
JAMES BOND: LICENCE TO KILL (1989)	522-524
JAMES BOND: LIVE AND LET DIE (1973)	183, 517
JAMES BOND: MOONRAKER (1979)	517
JAMES BOND: NEVER SAY NEVER AGAIN (1983)	519
JAMES BOND: OCTOPUSSY (1983)	184, 518
JAMES BOND: ON HER MAJESTY'S SECRET SERVICE (1969)	182, 516
JAMES BOND: SKYFALL (2012)	530-531
JAMES BOND: THE LIVING DAYLIGHTS (1987)	190, 521-523
JAMES BOND: THE SPY WHO LOVED ME (1977)	183, 517
JAMES BOND: THE WORLD IS NOT ENOUGH (1999)	525-527
JAMES BOND: TOMORROW NEVER DIES (1997)	189, 525
JAMES BOND: VARIOUS PRODUCTIONS	516
JAMES BOND: YOU ONLY LIVE TWICE (1967)	180-181, 516
JASON BOURNE (2016)	432
JASON GOES TO HELL: THE FINAL FRIDAY (1993)	126, 482, 486
JASON X (2001)	127, 484
JAWS (1975)	192
JAWS 3 (1983)	533
JAWS RIDE AT UNIVERSAL STUDIOS FLORIDA	533
JEEPERS CREEPERS 2 (2003)	533
JINGLE ALL THE WAY (1996)	534
JOE VERSUS THE VOLCANO (1990)	534
JOHN WICK: CHAPTER 3 – PARABELLUM (2019)	534
JOJO RABBIT (2019)	535
JUMANJI (1995)	193-194
JURASSIC PARK (1993)	535
JURASSIC PARK III (2001)	536
JURASSIC PARK: THE RIDE (1996 – 2018)	535
JURASSIC WORLD (2015)	536-537
JURASSIC WORLD: FALLEN KINGDOM (2018)	537
K	
K9 (TV. SERIES, 2009 – 2010)	465
KARATE KID, THE (1983)	195, 537
KAVANAGH QC (TV. SERIES, 1995-2001)	538
KIN (2018)	538
KINGSMAN: THE SECRET SERVICE (2014)	538
KNIGHT'S TALE, A (2001)	540
KRULL (1983)	196
L	
LABYRINTH (1986)	540-542
LADYKILLERS, THE (2004)	542
LARA CROFT TOMB RAIDER: THE CRADLE OF LIFE (2003)	543
LARA CROFT: TOMB RAIDER (2001)	542
LAST ACTION HERO (1993)	543

**DAY
01**

LOTS 1 – 448
PG. 7 – 387
NOV 3, 2022
THURS. 3:00 PM (GMT)
8:00 AM (PDT)

**DAY
02**

LOTS 449 – 623
PG. 7 – 133
NOV 4, 2022
FRI. 3:00 PM (GMT)
8:00 AM (PDT)

**DAY
03**

LOTS 624 – 1083
PG. 390 – 531
NOV 5, 2022
SAT. 3:00 PM (GMT)
8:00 AM (PDT)

**DAY
04**

LOTS 1084 – 1536
PG.532 – 670
NOV 6, 2022
SUN. 3:00 PM (GMT)
7:00 AM (PST)

See separate catalog containing Music Lots

Index

Film or Show	Page Number(s)	Film or Show	Page Number(s)
LAST SAMURAI, THE (2003)	544	PEAKY BLINDERS (TV. SERIES, 2013 – 2022)	566
LAW & ORDER: CRIMINAL INTENT (TV. SERIES, 2001 – 2011)	544	PET SEMATARY (1989)	567
LAWRENCE OF ARABIA (1962)	198-199	PETER PAN (2003)	567
LAYER CAKE (2004)	545	PHANTOM OF THE OPERA, THE (2004)	567
LEATHERFACE – THE TEXAS CHAINSAW MASSACRE III (1990)	197	PHANTOM, THE (1996)	238
LEGEND OF ZORRO, THE (2005)	545-546	PILLARS OF THE EARTH, THE (TV. SERIES, 2010)	568
LÉON: THE PROFESSIONAL (1994)	200-202	PIRATES OF THE CARIBBEAN: DEAD MEN TELL NO TALES (2017)	568
LETHAL WEAPON (1987)	202	PIRATES OF THE CARIBBEAN: ON STRANGER TIDES (2011)	239
LIGHTHOUSE, THE (2019)	546	PIRATES OF THE CARIBBEAN: THE CURSE OF THE BLACK PEARL (2003)	568
LITTLE NICKY (2000)	547	PLANET OF THE APES (1968)	239-240
LITTLE SHOP OF HORRORS (1986)	361	PLANET OF THE APES (2001)	570
LIVE FREE OR DIE HARD (2007)	454	PLANET OF THE APES (TV. SERIES, 1974)	570
LORD OF THE RINGS TRILOGY, THE (2001 – 2003)	548-549	POINT BREAK (1991)	241
LORD OF THE RINGS: THE FELLOWSHIP OF THE RING, THE (2001)	203, 549-550	POLAR EXPRESS, THE (2004)	570-572
LORD OF THE RINGS: THE RETURN OF THE KING, THE (2003)	203-205	POWER RANGERS TIME FORCE (TV. SERIES, 2001)	242
LOST (TV. SERIES, 2004 – 2010)	550	PREDATOR (1987)	242
LOST BOYS, THE (1987)	206-209	PRIEST (2011)	572
LOST IN SPACE (TV. SERIES, 2018 – 2022)	210-215, 551-552	PRINCE OF EGYPT, THE (1998)	572
LOVE GURU, THE (2008)	553	PRINCE OF PERSIA: THE SANDS OF TIME (2010)	243
LUCASFILM	611-612, 618	PROMETHEUS (2012)	244, 573-575
LUCIFER (TV. SERIES, 2016 – 2022)	553	PULP FICTION (1994)	245-247, 575
M			
M*A*S*H (TV. SERIES, 1972 – 1983)	557	PUNISHER, THE (2004)	249
MACBETH (2015)	554	PUPPET MASTER VS DEMONIC TOYS (2004)	575
MAN OF STEEL (2013)	554	Q	
MANDALORIAN, THE (TV. SERIES, 2019 – 2022)	346-347	QUENTIN TARANTINO: VARIOUS PRODUCTIONS	248
MARILYN MONROE	215-216, 555	R	
MARS ATTACKS! (1996)	555	RAIDERS OF THE LOST ARK (1981)	508-509
MARVEL'S AGENTS OF S.H.I.E.L.D. (TV. SERIES, 2013 – 2020)	556	RAIN MAN (1988)	576
MARY POPPINS RETURNS (2018)	217	RAMBO (2008)	249, 576-577
MASK, THE (1994)	218-219	RAMBO: FIRST BLOOD PART II (1985)	576
MATRIX RELOADED, THE (2003)	220, 557-558	RAMBO: LAST BLOOD (2019)	577
MATRIX, THE (1999)	556	RE-ANIMATOR (1985)	250-251
MCVICAR (1980)	558	RED DWARF (TV. SERIES, 1988 – 2022)	577
MEDUSA TOUCH, THE (1978)	558	RESERVOIR DOGS (1992)	252
MEN IN BLACK (1997)	558-559	RETURN TO OZ (1985)	578
MEN IN BLACK 3 (2012)	221, 559-560	REVENGE OF THE PINK PANTHER (1978)	579
MEN IN BLACK II (2002)	220, 222, 559	RISE OF THE PLANET OF THE APES (2011)	579
MINORITY REPORT (2002)	222-223	ROBOCOP (1987)	252-253
MISSION TO MARS (2000)	224	ROBOCOP (2014)	579
MISSION: IMPOSSIBLE – FALLOUT (2018)	223, 560-561	ROBOCOP TRILOGY (1987 – 1993)	252
MIST, THE (2007)	561	ROCK THE KASBAH (2015)	580
MONTY PYTHON	561	ROCKETEER, THE (1991)	580
MUMMY RETURNS, THE (2001)	561, 562	ROCKETMAN (2019)	581-583
MUMMY, THE (1999)	225-227, 561	ROCKY III (1982)	584
MUPPET CHRISTMAS CAROL, THE (1992)	562	ROGUE ONE: A STAR WARS STORY (2016)	342-343, 630
MUPPET SHOW, THE (TV. SERIES, 1976-1981)	562	ROMANCING THE STONE (1984)	584
MYSTERY MEN (1999)	563	ROMEO & JULIET (2013)	585
N			
NATIONAL TREASURE: BOOK OF SECRETS (2007)	563	RUNNING MAN, THE (1987)	254
NATURAL, THE (1984)	563	S	
NEAR DARK (1987)	228	SANTA CLAUSE 2, THE (2002)	585
NIGHTBREED (1990)	563-564	SAVING PRIVATE RYAN (1998)	254
NIGHTMARE BEFORE CHRISTMAS, THE (1993)	228	SAW (2004)	585
NIGHTMARE ON ELM STREET 3, A: DREAM WARRIORS (1987)	229-231	SCREAM 5 (2022)	255
NIGHTMARE ON ELM STREET 4, A: THE DREAM MASTER (1988)	564	SCREAM: THE TV. SERIES (TV. SERIES, 2015 – 2019)	255
NIGHTMARE ON ELM STREET 5, A: THE DREAM CHILD (1989)	231-232	SHALLOWS, THE (2016)	585
NORTH SEA HIJACK (1979)	565	SHARI LEWIS	542
O			
OCEAN'S THIRTEEN (2007)	565	SHAWSHANK REDEMPTION, THE (1994)	256-261
OMEN III: THE FINAL CONFLICT (1981)	565	SHERLOCK (TV. SERIES, 2010 – 2017)	261
OMEN, THE (1976)	234, 565	SHIVERS (1975)	261
ORVILLE, THE (TV. SERIES, 2017 – PRESENT)	234-235	SHORT CIRCUIT (1986)	262-265
OZ THE GREAT AND POWERFUL (2013)	566	SHORT CIRCUIT 2 (1988)	266-267
P			
PACIFIC, THE (TV. SERIES, 2010)	566	SIN CITY (2005)	591
PALE RIDER (1985)	236-237	SINISTER (2012)	594
PARKS AND RECREATION (TV. SERIES, 2009 – 2015)	566	SINISTER 2 (2015)	268
		SLEEPY HOLLOW (1999)	268, 592
		SMALL SOLDIERS (1998)	592
		SMALLVILLE (TV. SERIES, 2001-2011)	269
		SOLO: A STAR WARS STORY (2018)	344-345, 630



