

Propstore

# Entertainment Memorabilia Live Auction



Treasures from  
Film and Television



London

Nov 14 - 17, 2024



## Entertainment Memorabilia Live Auction

Nov 14 – 17, 2024,  
3:00 PM (GMT) / 7:00 AM (PST)

Days 1 and 2 Hosted Live from  
BAFTA, 195 Piccadilly  
London, W1J 9LN, England  
+44 (0) 1494 766485



Scan QR code to RSVP  
for the Pre-Auction  
drinks reception.

Bidding is available in-person (November 14 – 15 only), online, via telephone and via written absentee form. Bidders are advised to arrive early to register for in-person bidding (November 14 – 15 only). Bidders are also advised to register in advance of the auction days for online, telephone or absentee bidding. Please see the bidding registration document at the back of the catalog for additional information. Please note in-person bidding is not available on Days 3 & 4 (November 16 – 17); bids can be placed on Days 3 & 4 online, via telephone or written absentee form.

Lots are auctioned live and in-person by Propstore's auctioneer in sequential order. The catalogue identifies which day each lot will be offered. The live auction is streamed online at Propstore.com so bidders can follow all auction activity.

Propstore will host a pre-auction drinks reception at the BAFTA 195 Piccadilly from 2:00 PM to 3:00 PM (GMT) on Thursday 14th November. Select lots will be on display at the reception. Bidders are invited to attend the pre-auction drinks reception; please RSVP to support@propstore.com to confirm attendance.

A second pre-auction event will take place at 2:00 PM to 3:00 PM (GMT), Friday 15th November, featuring a special appearance by Matt Fink, famously known as Dr. Fink from Prince's band, The Revolution, followed by a Q&A session. Please RSVP to support@propstore.com to confirm attendance.

## Previewing Auction Lots

Lots can be previewed by special appointment at Propstore's London facility. These special appointment previews can be facilitated through Friday 8th November. Lots can also be previewed via electronic video calls. Contact us for additional information.

## How To Bid

### In-Person

In-person bidding is available on Days 1 & 2 only, at BAFTA 195 Piccadilly. Please arrive early to register for the auction or register online in advance; you will complete a copy of the bidder registration form on page 341. In-person bidding is not available for Days 3 & 4.

### Telephone

Complete the bidder registration form on page 341 and submit to Propstore to bid via telephone at least 24 hours in advance. One of Propstore's telephone bidding specialists will call you at your specified number and allow you to bid on your lot in real time.

### Online

Bid live from anywhere in the world via Propstore's live online Auction Platform. Register today at Propstore.com/Auction

### Absentee Form

Complete the bidder registration form on page 341 and submit to Propstore to bid via written absentee form at least 24 hours in advance; select the option for absentee bids and list your maximum bids. A clerk executes bids on your behalf in the room, up to the level necessary to beat other bidders.

### Bidding on High-Value Lots

New clients who have no prior purchase history with Propstore may need to meet additional registration requirements in order to bid on lots that have a low estimate of £50,000 and above. Please inquire for details.

## Terms & Info

### Conditions of Sale

This auction is governed by important stipulated terms, conditions and reserves. All stipulations can be found at propstore.com/liveauction and on page 328 of this catalog.

## Buyer's Premium and Credit/Debit Fee

A Buyer's Premium of 26% will be added to all winning bids.

### FRONT COVER IMAGES

140  
Ray Harryhausen Archive: Kali Lighting Stand-in Model  
by Ray Harryhausen M  
The Golden Voyage Of Sinbad (1973)

### Payment Plans

Payment plans may be available in increments of up to three (3) months for purchases where total Hammer Price and Buyer's Premium are greater than £2,000. Buyers wishing to utilize the payment plan service, if approved by Propstore, shall be required to pay a deposit of twenty percent (20%) of the Purchase Price (the "Deposit"), within seven (7) days of being invoiced. The balance of the Purchase Price shall then be split over up to three (3) months, at the Buyer's option; the maximum payment plan duration is 90 days from the close of the Auction. Note that select lots, as indicated in the description, will not have the payment plan option available. Contact Propstore in advance of bidding with any questions on payment plans.

### Reserves

Certain Lots in this auction may be sold without a Reserve Price; the majority of Lots are sold with a Reserve Price. The Reserve Price is the minimum price the Seller will accept for a Lot. The Reserve Price will not be more than the lowest estimate given by Propstore. Propstore may disclose or keep confidential the Reserve Price at its entire discretion.

### Live Auction Stream

The complete live auction event will be broadcast on propstore.com and viewable from anywhere in the world. Lots are sold in sequential order.

### Contact Propstore

Email: support@propstore.com  
UK Office: +44 (0) 1494 766485  
US Office: +1 818 727 7829

### Bidding Increments

The following are suggested bid increments for the Auction. Please be advised that they are suggested increments only, are not intended to be and shall not be binding, and the Auctioneer retains the sole and absolute discretion, at the time of the Auction, to change, modify, or vary the bid increments at any time.

- £100 – £300 by £25
- £300 – £500 by £50
- £500 – £2,000 by £100
- £2,000 – £5,000 by £250
- £5,000 – £10,000 by £500
- £10,000 – £20,000 by £1,000
- £20,000 – £50,000 by £2,500
- £50,000 – £100,000 by £5,000
- £100,000+ at the Auctioneer's discretion

## VAT & Sales Tax

All stipulations can be found at propstore.com/liveauction. Please note, some of the items in this sale attract VAT (see clause 75.) Due to the US Wayfair ruling, US sales tax may apply to US buyers from select US states (see clause 717.)

Follow the auction on Propstore's social media platforms  
#PropstoreLiveAuction



# Propstore

# Entertainment Memorabilia Live Auction



Nov 14 – 17, 2024

London

[propstore.com/liveauction](https://propstore.com/liveauction)

## Day 1

Thursday,  
November 14  
Film & Television

\*lots illustrated in this catalog

Lots 1 – 429

In-Person Bidding  
BAFTA 195 Piccadilly

## Day 2

Friday,  
November 15  
Music

\*see separate printed catalog

Lots 430 – 818

In-Person Bidding  
BAFTA 195 Piccadilly

## Day 3

Saturday,  
November 16  
Film & Television

\*online catalog only

Lots 819 – 1334

Online, Telephone and  
Absentee Bidding Only

## Day 4

Sunday,  
November 17  
Film & Television

\*online catalog only

Lots 1335 – End

Online, Telephone and  
Absentee Bidding Only

Auction Begins 3:00 PM (GMT) / 7:00 AM (PST) Each Day  
Online, Telephone and Absentee Bidding Available on All Days  
**The catalog for lots on Days 3–4 is available online only**  
All days streamed live at propstore.com

\* Certain films and shows have Lots offered on more than one day of the Auction; see Index on page 336 for a complete listing of available Lots by film or show title

### About Propstore

Propstore was founded on the belief that the props and costumes used in movies are pieces of art—film art. We see these artifacts not as mere by-products of the production process, but as unique, creative works in their own right. The result of the collective effort of designers, fabricators, and artisans from every corner of the globe, many of these pieces are simply extraordinary.

Private collectors have played a significant role in preserving these film art pieces since the earliest days of cinema and television. Throughout the entertainment industry's history, these items were considered as mere production tools and were therefore commonly discarded time and time again. Private collectors have stepped in on many occasions and taken preservation into their own hands. Some film and television artifact collecting stories are legendary: A college student walking through a field and stumbling upon the model miniature space station from 2001: A Space Odyssey after the item was dumped from an unpaid storage locker, for example. Many of cinema's most memorable treasures are cared for by private collectors, and we believe that private collectors continue to play a critical role in the overall preservation and legacy of film and television history. Collecting is a very personal thing as all collectors have different tastes—but collectors are united through a common passion for the material and its preservation.

Each of Propstore's team members share this belief and are long-time, passionate collectors themselves. We love this material. We revere this material. Our enthusiasm is the driving force in our two and a half decade global search to locate these culturally-significant items. Our journey has enabled us to forge key relationships within the industry that have

provided access to material previously believed to be unavailable. We are also in continuous contact with those on the front lines of production. These individuals educate us and assist us in properly identifying and authenticating material. In turn, we have educated and supported the collecting community by sharing our knowledge through articles, videos and collecting websites and forums.

We are excited to share this catalog with collectors around the world. Within this sale you will find pieces available at every price point—all of which are authenticated and certified with our industry-leading certificate of authenticity and its accompanying guarantee. Each of these pieces satisfy our strict internal authentication standards.

We strive to present these pieces with the same level of care that went into their presentation on screen, as they deserve nothing less. A large portion of the artifact collection will be on public exhibition prior to the sale, providing a first-hand view of the material. Whether you are a veteran collector or just getting started, we hope that you find pieces that speak to you amongst this truly unique offering. To make this material more accessible, all items over £2,000 can be purchased on an interest-free payment plan. We can also pack and ship material safely to any destination in the world.

Our experience, passion and desire to source the most exciting pieces possible makes us one of the world's leading vendors of original props, costumes and collectible memorabilia. We look forward to being a part of your own collecting journey and to helping you preserve these beloved pieces of film and television history.

### The Propstore Certificate of Authenticity

Authenticity is the defining collectible element for original film and television props and costumes. All of our certificates carry multiple security elements to verify authenticity, representing a lifetime guarantee that the item is a genuine piece of cinema history exactly as described. Propstore's complete Terms of Guarantee can be found on page 334.



# Propstore

# Sell Your Movie Memorabilia

Achieve world record prices for  
entertainment memorabilia

### Batman (1989)

Screen-Matched Batman's  
(Michael Keaton) Batwing Six-Foot  
Motorized Filming Model

sold for \$409,500 (£327,600)\*



Reach out for a free appraisal  
and valuation with our specialists

QR code with Propstore logo  
Email: [consign@propstore.com](mailto:consign@propstore.com)  
UK Office: +44 (0) 1494 766485  
US Office: +1 818 727 7829

Scan QR code to visit [propstore.com/props](http://propstore.com/props)

# Day 1

Lots 1 - 429

November 14, 2024

In-Person Bidding

BAFTA 195 Piccadilly

3:00 PM (GMT) / 7:00 AM (PST)



\*Certain films and shows have Lots offered on more than one day of the Auction; see Index on page 336 for a complete listing of available Lots by film or show title

## THE KEITH HAMSHERE COLLECTION

Keith Hamshere started his career in the entertainment industry as an actor and played the title character in the world's first production of Lionel Bart's musical *Oliver!*, which was later turned into a multi-Oscar-winning film in 1968. Hamshere later starred in the Disney film *In Search of the Castaways* and Michael Winner's film *Play it Cool*.

Hamshere started working in London's photographic scene in the 1960s and was invited by unit photographer Johnny Jay to work on Stanley Kubrick's *2001: A Space Odyssey*. Hamshere became close with Kubrick and was trusted to run a photographic department shooting large format images for animation. He was sent to South Africa to shoot plates for the "Dawn of Man" sequence, and the work Hamshere and his crew produced in the film still stands up today.

After his work on *2001*, Hamshere became a renowned stills photographer and worked with Steven Spielberg on *Indiana Jones and the Temple of Doom*, as well as establishing strong working links with Lucasfilm and Eon Productions. Hamshere worked on the *Bond* franchise until his retirement.

His other credits include *Willow*, *Barry Lyndon*, *The Mummy*, *Chaplin*, *Star Wars: Episodes I-III*, *Band of Brothers*, and many more. His work has helped create some of the most iconic images and posters for some of the biggest movies of all time.

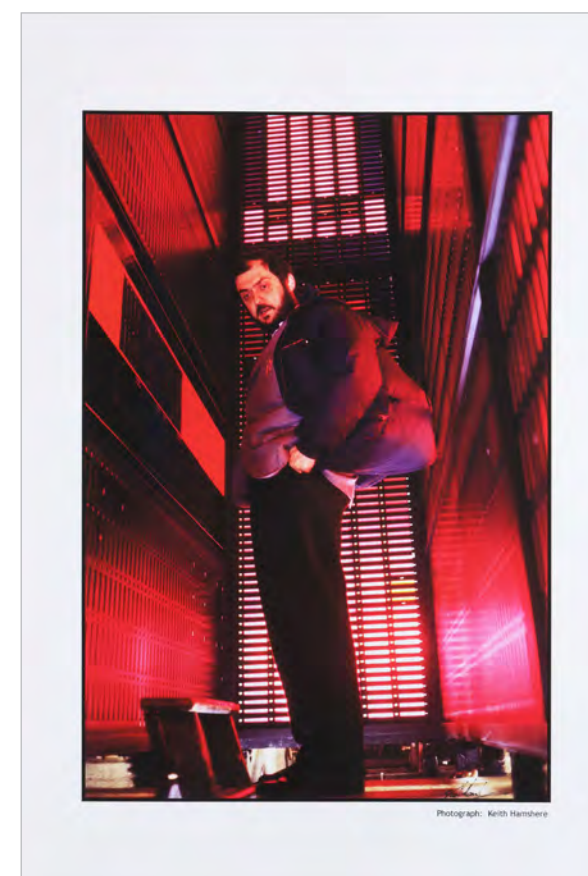

### 1 Keith Hamshere Collection: Pair of Previously Unseen Behind-the-Scenes Photographs from *2001: A Space Odyssey* (1968)

A pair of previously unseen behind-the-scenes photographs from the production of Stanley Kubrick's sci-fi masterpiece *2001: A Space Odyssey*. This lot comes from the personal collection of renowned stills photographer Keith Hamshere.

These two images, printed for the very first time by the photographer, depict the filming of the scene in HAL's processor core. One features Kubrick in a thoughtful pose, standing inside HAL. The other depicts Keir Dullea as Dr. Dave Bowman in his spacesuit, apparently floating over the same set. Hamshere believes that neither picture had ever been seen publicly in the 56 years since the production, making this an incredibly rare opportunity to own a unique piece of sci-fi history. The photograph of Kubrick can now be seen in Hamshere's book of his career - "Life Through an Aperture: The Films and Photography of Keith Hamshere" - published in October 2024.

Each photograph is printed on Epson Premium Luster paper, and is signed by Hamshere, with "Photograph: Keith Hamshere" printed in the bottom right corner. Dimensions (each): 48.5 cm x 33 cm (19" x 13")

Sold without copyright; see copyright notice in the Buyer's Guide.

**Estimate: £4,000 - 8,000**



**2**  
Leonidas' (Gerard Butler) Partial Costume with  
Captain Artemis' (Vincent Regan) Helmet m  
**300 (2006)**

Leonidas' (Gerard Butler) partial costume with a Captain Artemis (Vincent Regan) helmet from Zack Snyder's historical action film 300. Leonidas and Artemis wore their costumes throughout the film as they held off the invading Persian army at the Battle of Thermopylae.

The costume consists of a heavy red canvas cape (labelled "#1 Leonidas Step 5"); a brown leather codpiece (labelled "Leonidas "D" Butler"); a pair of resin fibulae (labelled "Leonidas"); and a pair of faux hair braids for adhering into helmets. It is accompanied by a fibreglass helmet labelled "Captain Stage 4". The helmet is intentionally distressed with slash marks and stage blood, and the entire costume is distressed to look well worn and battle damaged.

**Estimate: £7,000 - 14,000**



**3**  
Stelios Stunt Costume m  
**300 (2006)**

A Stelios stunt costume from Zack Snyder's historical action film 300. Stelios (Michael Fassbender) wore his costume as he fought alongside Leonidas (Gerard Butler) against the invading Persian army at the Battle of Thermopylae.

The costume consists of a rubber helmet (labelled "Tim Rigby"); a long red canvas cape ("Stelios Stunt #2/#6"); a resin brooch ("Stelios P/3"); two leather codpieces ("Stelios A" and "Stelios Stunt "A""); a leather belt ("Stelios Stunt"); a pair of rubber greaves ("Stelios" and "Ryan Watson 5"); a pair of bracers ("#106 Stelios Stunt Phase 3"); and a pair of leather sandals. The pieces have been intentionally distressed to appear battle-scarred, and the armour pieces are stained with sticky stage blood.

**Estimate: £7,000 - 14,000**



**4**  
David Norris' (Matt Damon)  
Adjustment Bureau Trilby Hat m  
**The Adjustment Bureau (2011)**

David Norris' (Matt Damon) Adjustment Bureau trilby hat from George Nolfi's The Adjustment Bureau. Harry Mitchell (Anthony Mackie) gave David his Adjustment Bureau hat which David wore during his escape from the bureau in the rain to get back to his relationship with Elise Sellas (Emily Blunt).

This lot consists of a grey Fina Panama Montecristi stitched trilby hat with a black striped nylon ribbon. The interior lining of the hat is labelled "david dup #2." This lot exhibits loose threads and a white residue on the interior.

**Estimate: £3,000 - 6,000**

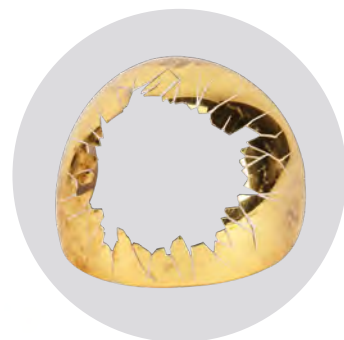

The visor insert has been intentionally distressed and is stained with stage blood

**5**  
Complete Spacesuit with Captain Lawrence Tanner's (Donnie Keshawarz) Visor Insert  $\Omega$   
**Ad Astra (2019)**

A complete spacesuit with Captain Lawrence Tanner's (Donnie Keshawarz) visor insert from James Gray's sci-fi adventure Ad Astra. Tanner and Roy McBride (Brad Pitt) wore their spacesuits while investigating a distress signal aboard a passing biomedical research station. Tanner was subsequently attacked and killed by a feral baboon aboard the ship.

The spacesuit comprises a jumpsuit; a helmet; a pair of mismatched gloves; a belt and holster (labelled "Tanner #1"); a pair of boots; a backpack; and a cracked acrylic visor insert for Tanner's death scene. The visor insert has been intentionally distressed and is stained with stage blood. The gloves are of two different sizes.

**Estimate: £3,000 - 6,000**

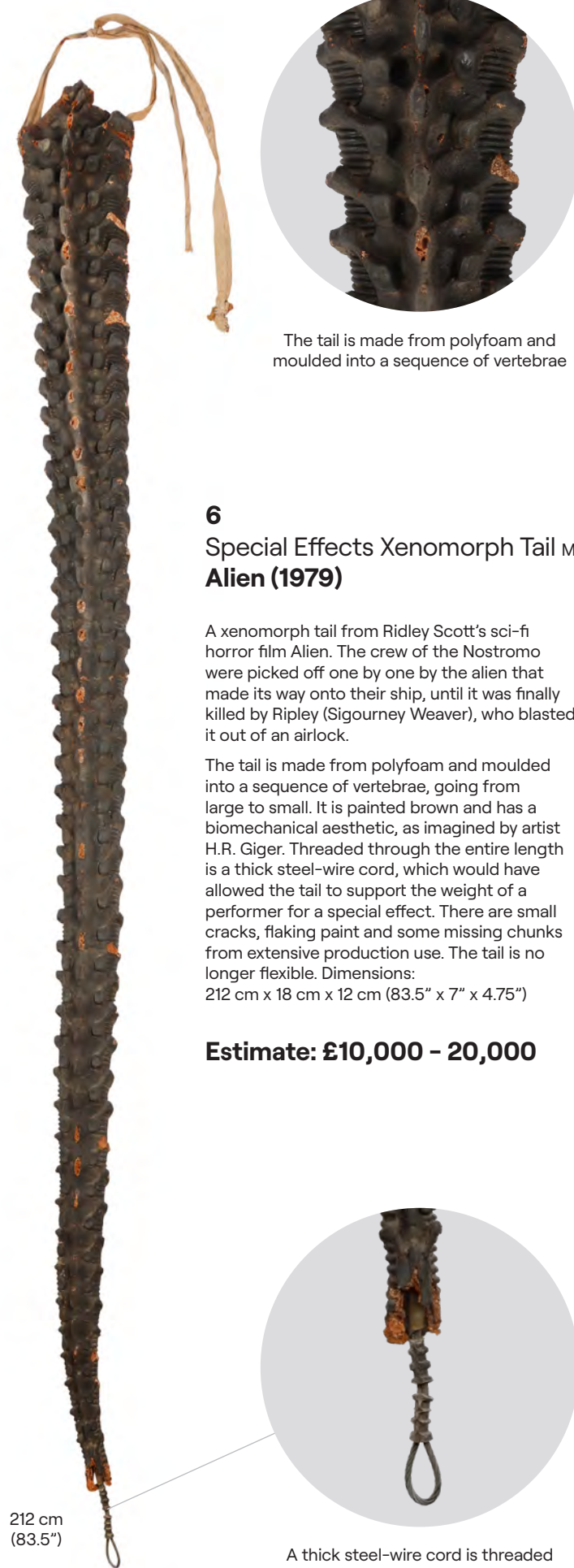

The tail is made from polyfoam and moulded into a sequence of vertebrae

**6**  
Special Effects Xenomorph Tail  $M$   
**Alien (1979)**

A xenomorph tail from Ridley Scott's sci-fi horror film Alien. The crew of the Nostromo were picked off one by one by the alien that made its way onto their ship, until it was finally killed by Ripley (Sigourney Weaver), who blasted it out of an airlock.

The tail is made from polyfoam and moulded into a sequence of vertebrae, going from large to small. It is painted brown and has a biomechanical aesthetic, as imagined by artist H.R. Giger. Threaded through the entire length is a thick steel-wire cord, which would have allowed the tail to support the weight of a performer for a special effect. There are small cracks, flaking paint and some missing chunks from extensive production use. The tail is no longer flexible. Dimensions: 212 cm x 18 cm x 12 cm (83.5" x 7" x 4.75")

**Estimate: £10,000 - 20,000**



A thick steel-wire cord is threaded through the entire length

**7**  
Nostromo Spacesuit  $M$   
**Alien (1979)**

A Nostromo spacesuit from Ridley Scott's sci-fi horror Alien. Spacesuits were hung up around the spaceship Nostromo, and some can be seen close-up in the escape-shuttle closet when Ripley (Sigourney Weaver) hid from the alien before blasting it out into space.

This spacesuit was originally a 1960s pilot's high-altitude pressure suit, with modifications made by the production's costume department. It is made from a thin white material which has tubes sewn into it, and the suit ties up at the back. The gloves have soft rubber additions, and there is a panel on the midsection with buttons and a dial. The costume is discoloured and features a number of stains.

**Estimate: £6,000 - 12,000**



There is a panel on the midsection with buttons and a dial



Detailed sculpt depicting the Space Jockey



**8**  
Space Jockey Plaster Maquette  $M$   
**Alien (1979)**

A Space Jockey maquette from the production of Ridley Scott's sci-fi horror film Alien. Maquettes were created during pre-production to develop the appearance of the final, full-scale Space Jockey seen in the film.

This maquette is a white plaster cast of a detailed sculpt depicting the Space Jockey seated in its spacecraft-piloting apparatus. It has some minor wear, including paint markings. Dimensions: 40.75 cm x 12.75 cm x 25.5 cm (16" x 5" x 10")

**Estimate: £5,000 - 10,000**



LANDMARK MEDIA / Alamy Stock Photo

**9**  
**Full-size Caterpillar P-5000 Powered Work Loader Arm**  
**Aliens (1986)**

A full-size Caterpillar P-5000 powered work loader arm from James Cameron's Aliens. In the climactic finale, Ellen Ripley (Sigourney Weaver) commandeered a high-tech power loader to fight the xenomorph Queen aboard the USS Sulaco.

The P-5000s were designed by renowned production designer Syd Mead in collaboration with Cameron. Both full-size and model miniature versions were created for the Queen battle, with the larger mechanised exoskeleton constructed around and operated from the inside by stuntman John Lees with Weaver in the operator's seat.

The resulting sequence is considered among the greatest ever produced in science-fiction cinema, contributing to the film's massive box office grosses and earning seven Academy Award® nominations, including wins for both Best Visual Effects and Best Sound Effects Editing. Since the film's release, Ripley's power loader has been immortalised in toys, arcade games, and references in other popular media.

Labelled "Power Loader 2" and stamped "N1724," this full-size jointed arm is constructed from vacuum-formed plastic inset with metal rods. A static dense rubber controller with a rubber telephone cord attached is mounted to one side, while a rotatable wheel is mounted to a rod protruding from the base. The interior features a slot for inserting a stuntperson's arm. Also included is a replica of the round foam wheel component at the wrist between the claw and upper arm.

The arm is applied with red decals and intentionally distressed by production to appear well-used with grime, blood staining, and liquid streaks added to the surface. It is believed to have been repainted yellow with industrial black striping and detailing down its length following production, giving it a slightly different appearance from what is seen in the final cut. The plastic exhibits breaks throughout, including missing panels on either end of the arm and cracks along its joints, as well as flaking paint from age and production. Dimensions: 185.5 cm x 63.5 cm x 76.5 cm (73" x 25" x 30")

Special shipping required; see notice in the Buyer's Guide.

**Estimate: £40,000 - 80,000**



Detail of inside of arm

185.5 cm  
(73")

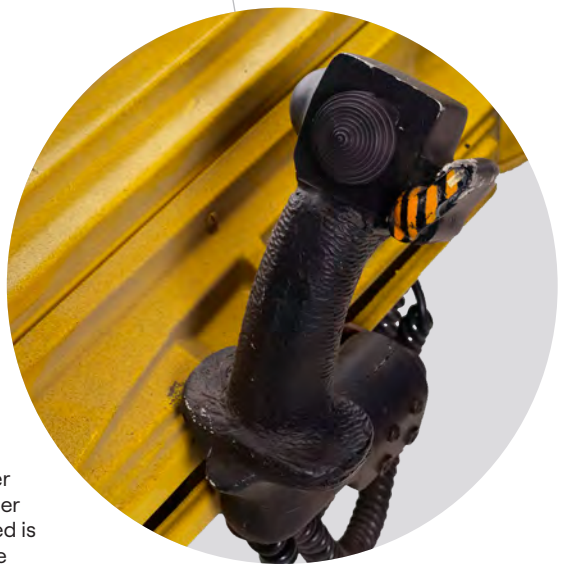

A static dense rubber controller with a rubber telephone cord attached is mounted to one side





**10**  
Lightweight M-41A Pulse Rifle  
**Aliens (1986)**

An M41A Pulse Rifle from James Cameron's sci-fi action sequel Aliens. Pulse Rifles were wielded by the Colonial Marines while they searched Hadley's Hope for survivors. Lightweight Pulse Rifles were used frequently during production, as they were easier for actors to handle and more suitable for action sequences. Made of resin, expanding foam and wood, this lightweight prop rifle was designed by director James Cameron and realised by Simon Atherton, the head of movie armourers Bapty & Co. The rifle is based on a World War II-era M1A1 Thompson submachine gun, with a SPAS-12 shotgun cage below the barrel to simulate a grenade launcher. The piece is painted green-brown and black, and has some paint wear from production and age.  
Dimensions: 69.75 cm x 7.5 cm x 26.75 cm (27.5" x 3" x 10.5")

**Estimate: £25,000 - 50,000**

**11**  
Production-made Hadley's Hope Colony Vehicle  
Model Miniature  
**Aliens (1986)**

A production-made model miniature Hadley's Hope colony vehicle from James Cameron's sci-fi action sequel Aliens. An abandoned vehicle appeared in the deserted streets of Hadley's Hope when the Colonial Marines first landed on the planet LV-426. The colony and its vehicles were designed by legendary concept artist Ron Cobb, who also worked on Star Wars, Raiders of the Lost Ark, Conan the Barbarian, and Back to the Future. This 1:12 scale vehicle was made by the production and completed in the workshops during post-production when the paintwork was finished, and the wheels added.

The vehicle is made primarily of PVC and has a highly detailed finish. It is hand-painted and airbrushed to look weathered and dirty, and features six wide-tracked wheels which can spin. Dimensions: 48 cm x 34 cm x 28 cm (19" x 13.5" x 11")

**Estimate: £10,000 - 20,000**



The vehicle is hand-painted and airbrushed to look weathered and dirty



48 cm (19")

80 cm  
(31.5")



**12**  
Full-size Xenomorph Egg m  
**Aliens (1986)**

A full-size xenomorph egg from James Cameron's sci-fi action sequel Aliens. In one of the most iconic scenes in the franchise, Ripley (Sigourney Weaver) found herself in a showdown with the Alien Queen, surrounded in her nest by xenomorph eggs. These eggs are a crucial part of the Alien series, and feature prominently on posters for both Alien and Aliens.

This brown, beige and grey fibreglass egg is closed at the top but is hollow and features a hole at the base. It is hand-painted to look organic and has evidence of scorch marks from the final scenes, where Ripley used her flamethrower to torch the eggs. It has some wear from production use and age, including cracked paint and minor chips. Dimensions: 80 cm x 50 cm x 50 cm (31.5" x 19.75" x 19.75")

**Estimate: £10,000 - 20,000**

**13**  
Xenomorph Egg Miniature with Base tΔ  
**Aliens (1986)**

A xenomorph egg with a base from James Cameron's sci-fi action sequel Aliens. Eggs were seen in the nest of the Alien Queen when Ripley (Sigourney Weaver) arrived there to rescue Newt (Carrie Henn).

This egg would have been used for miniature sets of the Queen's nest. Both the egg and its base are made of hand-painted fibreglass. The egg slots into the centre of the base, which features a veiny, organic design. Some of the base's tendrils have broken off. Dimensions (egg on base): 27 cm x 27 cm x 33 cm (10.5" x 10.5" x 13")

**Estimate: £5,000 - 10,000**

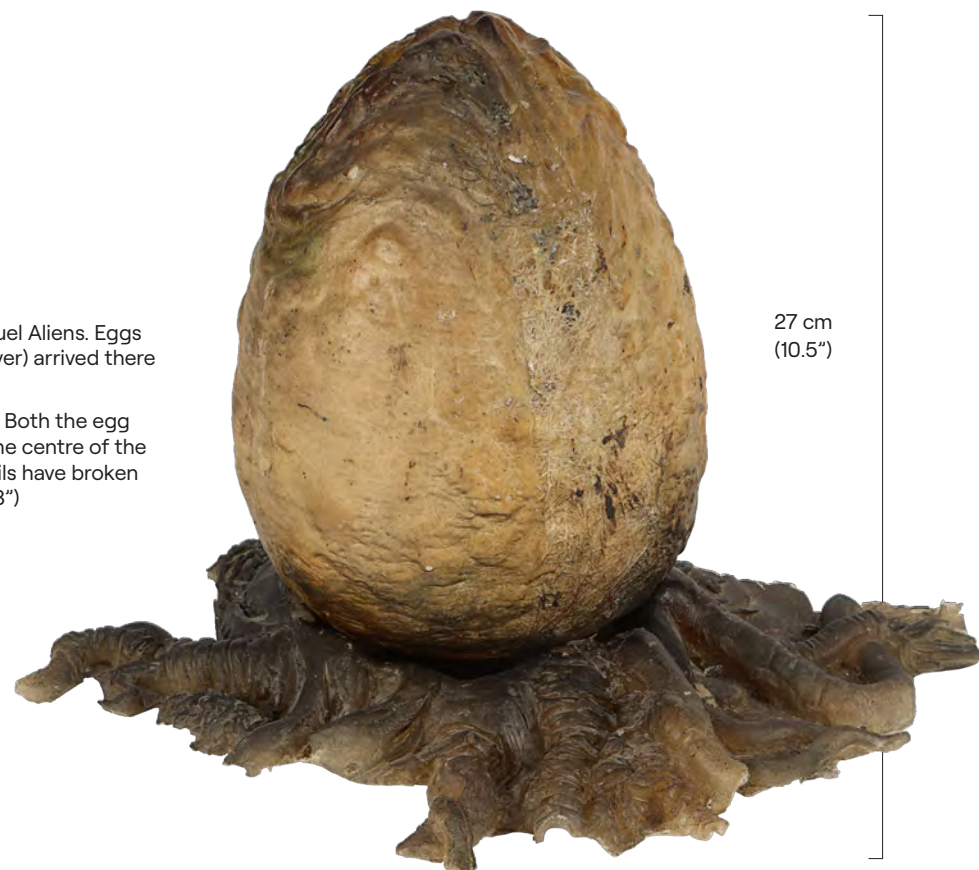

27 cm  
(10.5")



**14**  
Facehugger Stasis Tube Ω  
**Aliens (1986)**

A facehugger stasis tube from James Cameron's Aliens. As Ellen Ripley (Sigourney Weaver) and the Colonial Marines investigated the colony they found alien facehuggers in containment tanks, with one still alive inside its tube.

This stasis tube is composed of a hollow acrylic cylinder with metal, wood, and resin components. The top of the tube has two toggle switches and a hose attachment. The bottom features a panel of lights and wires. This lot has undergone sympathetic restoration and has had the lights replaced with LED strips. This lot exhibits discoloration, a build-up of grime, and a crack to the tube's frame. Dimensions: 33 cm x 33 cm x 86.5 cm (13" x 13" x 34")

Contains electronics; see electronics notice in the Buyer's Guide.

**Estimate: £8,000 - 16,000**



Screen captures from video footage



**CHRIS WARREN & ASSOCIATES** ACT  
IN ASSOCIATION WITH  
**VT RECORDING** IN ASSOCIATION WITH

SLATE	TK	COUNTER TIME	REMARKS	SLATE
			FOR SC 79	
			SUB LEVEL 3 (Cont)	
17	00	0:04	Hudson (Bill Paxton)	
18	04	0:17		
19	12	0:32		
20	32	0:43		
21	43	0:58		
22	58	1:14		
23	14	1:29		
24	29	1:44		



**15**  
Helmet Cam Footage Tape Archive Ω  
**Aliens (1986)**

A helmet cam footage tape archive from the production of James Cameron's Aliens. The Colonial Marines wore helmet cameras as they entered Hadley's Hope and descended into the sublevels of the power station containing the Xenomorph hive, with Lt. Gorman (William Hope) monitoring the camera feeds from the video station aboard the APC.

Much like its predecessor, Aliens was a commercial and critical success, earning Sigourney Weaver an Academy Award® nomination for Best Actress, the first such nomination given for a science-fiction film.

This archive of 12 three-quarter-inch format video cassette tapes consists of the POV footage from those helmet cameras, including Hudson (Bill Paxton), Hicks (Michael Biehn), Vasquez (Jenette Goldstein), Frost (Ricco Ross), and Drake's (Mark Rolston) POVs; as well as playback elements for the motion tracker. Each of the tapes comes in labelled plastic boxes, 10 in black Sony U-Matic boxes and two in grey Fuji Videocassette boxes. The total combined runtime of the tapes is approximately two hours and nine minutes. A digital file of the footage will also be included with the tapes. Due to being on video tape, the footage understandably exhibits the types of visual artefacts common to the format. Dimensions: (each) 25.5 cm x 17.25 cm x 4 cm (10" x 6.75" x 1.5")

Contains mechanical components; see notice in the Buyer's Guide.

**Estimate: £4,000 - 8,000**

"ALIENS"

THE FUTURE - SPACE

FADE IN:

1 SOMETIME IN THE FUTURE - SPACE

Silent and endless. The stars shine like the love of a cold and remote. Against them drifts a tiny chip of technology.

CLOSER: It is the NARCISSUS, lifeboat of the ill-fated star freighter Nostromo. Without interior or running lights it seems devoid of life. The PING of a RANGING RADAR grows louder, closer. A shadow engulfs the Narcissus. Searchlights flash on, playing over the ship, as a MASSIVE DARK HULL descends toward it.

2 INT. NARCISSUS

Dark and dormant as a crypt. The searchlights stream in the dusty windows. Outside, massive metal forms can be seen descending around the shuttle. Like the tolling of a bell, a BASSO PROFUNDO CLANG reverberates through the hull.

CLOSE ON THE AIRLOCK DOOR: Light glares as a cutting torch bursts through the metal, moving with machine precision, cutting a rectangular path. The torch cuts off. The door falls inward revealing a bizarre multi-armed figure. A ROBOT WELDER.

FIGURES enter, back-lit and ominous. THREE MEN in bio-isolation suits, carrying lights and equipment. They approach a sarcophaguslike HYPERSLEEP CAPSULE, f.g. The leader's gloved hand wipes at an opaque layer of dust on the canopy.

ANGLE INSIDE CAPSULE: as light stabs in where the dust is wiped away, illuminating a WOMAN, her face in peaceful repose. WARRANT OFFICER RIPLEY sole survivor of the Nostromo. Nestled next to her is JONES, the ship's wayward cat.

LEADER  
Bio-readouts are all in the green. She's alive. Well, there goes our salvage, guys.

DISSOLVE TO:

2A EXT. SPACE / EARTH ORBIT

PANNING across the serene blue curve of Earth as seen from high orbit onto GATEWAY STATION, a sprawling complex of

(CONTINUED)

16 James Cameron's Heavily Annotated Personal Shooting Script m Aliens (1986)

James Cameron's heavily annotated personal shooting script from the production of Cameron's sci-fi action sequel Aliens. Three-time Academy Award-winning director Cameron wrote and directed the film, having formulated the story alongside producers David Giler and Walter Hill. Cameron is a credited writer on all of the films he has directed.

The script is 106 pages long and is bound with metal fasteners. Fifteen pages feature handwritten annotations, including notes on shots and additional or altered dialogue; eight pages have dialogue crossed out; and one page has a hand-drawn sketch of what appears to be Newt's (Carrie Henn) family before her father is attacked by a facehugger. The script no longer has a title page or front cover, and the pages and back cover have some staining and edge wear. Dimensions: 28 cm x 22 cm x 1.5 cm (11" x 8.75" x 0.5")

Estimate: £20,000 - 40,000

"ALIENS"

THE FUTURE - SPACE

endless. The stars shine like the love of a cold and remote. Against them drifts a tiny chip of technology.

It is the NARCISSUS, lifeboat of the ill-fated star freighter Nostromo. Without interior or running lights it seems devoid of life. The PING of a RANGING RADAR grows louder, closer. A shadow engulfs the Narcissus. Searchlights flash on, playing over the ship, as a MASSIVE DARK HULL descends toward it.

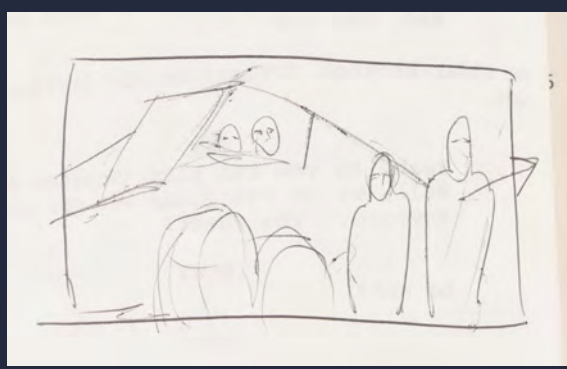

F- Move it Spunk, we're rolling

S- I'm in. Ramp closing Hang on a second, there's something...

F- Just got up here

S- Roger.

Diehrich? Diehrich?  
Hicks - Crowe and Wierzbowski area down. Crowe's off the board. Frost's off the board, repeat Frost's off the board - I got multiple signals behind, repeat, they're in the tunnel - (he fires Jesus! shotgun)

do they leave a tracker as a remote alarm?

Cut to Hicks at Tac-board (119A) then to 119, Newt/Burke working, pass Ripley, Hicks welding

BISHOP  
Four hours. The blast radius will be about thirty kilometers. About equal to twenty megatons.

HICKS  
We got problems.

HUDSON  
I don't fucking believe this. Do you believe this?

RIPLEY  
Why can't we shut it down from here?

BISHOP  
I'm sorry. The crash did too much damage. The overload is inevitable, at this point.

HUDSON  
Oh, man. And I was gettin' short, too! Four more weeks and out. Now I'm gonna buy it on this fuckin' rock.

CONTINUED

12 CROWE and WIERZBOWSKI light, horrified, to see the beam from the... VOOM! They are ambushed forward by the blast, with Crowe striking a pillar head-on.

13 INT. APC  
RIPLEY watches Crowe's monitor again and go black. Frost's and Wierzbowski's have turned to static head-up. Their head-sets go FLAT-LINE.

14 INT. COCON CHAMBER  
JONES Christ! What's going on?  
HUDSON What's going on?  
HUDSON Let's look.  
HUDSON They OPEN UP simultaneously. Vasquez moves fastest-punch in a pivoting dance. Thunder and lightning. Better than see for her.

15 INT. APC  
HUDSON Who's firing, goddamnit? I ordered GET THEM OUT OF THERE! DO IT NOW!  
HUDSON Shut up! Just shut up! Oh... Apone, I want you to lay down a suppressive fire with the incinerators and fall back by squads to the APC, over.

16 INT. COCON CHAMBER  
HUDSON (voice over: heavy static) Say again? All after incinerators?  
HUDSON I said...  
HUDSON Apone adjusts his headset.  
HUDSON (voice over: static) ... lay down (static)... squads to ... (static)

CONTINUED

17 HUDSON (voice over: static) ... lay down (static)... squads to ... (static)

18 INT. SERVICE TUNNEL - HUDSON  
A long straight service tunnel. Flood with condensation, seems to go on forever. Vasquez and Hudson have finished setting up two of the robot sentry guns on tripods in the tunnel.

19 INT. SECOND LEVEL CORRIDOR  
Hicks passes to his work.

CONTINUED

20 BISHOP  
Believe me, I'd prefer not to. I may be synthetic but I'm not stupid.

RIPLEY  
All right. Let's get on it. What'll you need?

VASQUEZ  
Listen. It's stopped. They're through the doors.

HICKS  
Well, they're into the complex.

INT. MED LAB  
One of the acid holes from the colonists' seige has yielded access to sub-floor conduits. Bishop, lying in the opening, reaches up to grasp the portable terminal as Ripley hands it down to him. He pushes it into the constricted shaft ahead of him. She then hands him a small



**17**  
**Full-size Promotional Alien Queen m**  
**Aliens (1986)**

A full-size Xenomorph Queen replica from the promotion of James Cameron's sci-fi action sequel Aliens. Ripley (Sigourney Weaver) came face to face with the Queen while searching for Newt (Carrie Henn). The Queen then pursued them back to the USS Sulaco, where Ripley managed to blast her out of the airlock.

James Cameron and Stan Winston designed and created the original creature for the film. This particular model was commissioned by the film studio to promote the release of the Alien Trilogy VHS box set in 1993. Built at Pinewood Studios from the original production moulds, it was constructed by sculptor Bruce Hansing, who did the fibreglassing, alongside Dave Chagouri and Oscar®-winner Dave Elsey, who together performed the foam work. Chagouri worked on Aliens, and both he and Elsey worked on David Fincher's Alien³.

The model is one of four made in total. After being used to promote the VHS release, it was featured in the London Science Museum's "The Science of Aliens" tour. The museum made the display stand and base for the tour, and both have embedded lights to illuminate the creature, powered by a US 120V plug.

The model itself is predominantly made of fibreglass with a metal frame. The foam tail sweeps down from the back of the body and is held with a metal strut. The arms and hands are also made of foam. Six new spines have been added to the back to complete the display.

There is some wear from age and use, as well as scuffs and scratches to the paintwork, chips in the fibreglass, and small holes on some parts of the Queen. Part of the clear acrylic around the base has snapped off. Dimensions: 345 cm x 250 cm x 260 cm (135.75" x 98.5" x 102.25")

Contains electronics; see electronics notice in the Buyer's Guide.

Special shipping required; see special shipping notice in the Buyer's Guide.

**Estimate: £20,000 - 40,000**



345 cm  
 (135.75")



249 cm  
(98")



**18**  
**Wolf (Ian Whyte) Predator Costume Display m**  
**AVPR: Aliens Vs. Predator - Requiem (2007)**

A Wolf (Ian Whyte) Predator costume display from The Brothers Strause's sci-fi action sequel Aliens vs. Predator: Requiem. The hunter known as Wolf (Ian Whyte) crash-landed in Gunnison, Colorado to dispatch the murderous Predalien born at the conclusion of Paul W.S. Anderson's Alien vs. Predator.

This full-size display consists of costume pieces created by Academy Award-winning special effects group Amalgamated Dynamics, Inc. (ADI). It includes a mottled green, yellow and brown foam latex skin bodysuit with Wolf's personalised netting; a head cowl with black foam-rubber dreadlocks; airbrushed silver rubber body armour over the left shoulder, breast, knees and calves; a spiky black rubber wrap-around necklace; a brown leather bandolier; a pair of foam feet with snap-button ankle closures and silver resin toe-blades affixed; mounted back-armor and shoulder cannon, and a pair of dense rubber wrist gauntlets, one of which is made to look partially destroyed. A replica helmet cast from original moulds, and a replica waist-skirt with a production-made center component complete the piece for display.

This costume is purposely distressed with grime, and detailed with otherworldly Yautja designs first made famous in John McTiernan's Predator. It is mounted on a fibreglass mannequin with a sturdy metal armature and affixed to a wooden base for display purposes. It exhibits various cracks and wear to the foam rubber throughout. Dimensions (displayed): 91.5 cm x 84 cm x 249 cm (36" x 33" x 98")

Special shipping required; see special shipping notice in the Buyer's Guide.

**Estimate: £15,000 - 30,000**



**19**  
**Terry English Handmade Replica Hudson (Bill Paxton)**  
**Colonial Marine Armour m**  
**Aliens (1986)**

A replica Hudson (Bill Paxton) costume made by renowned armourer Terry English, who designed and built the Colonial Marines' armour for James Cameron's sci-fi sequel Aliens. Terry's replica Colonial Marine armour sets are exclusively available through Propstore's auctions.

This lot consists of an aluminium helmet with an attached camera, earpiece and infrared sight; camouflage-pattern-painted aluminium chest and back armour linked together with web belting; vinyl-padded aluminium abdominal plates; a web belt and holster with plastic buckles; and foam-padded aluminium greaves marked "2R" and "2L" inside. The armour has "Hudson" stencilled on the chest, with "Louise", a skull and crossbones and the words "or Glory" painted on the left breast. "Contents under pressure dispose of properly" and a pair of eyes are painted on the back armour, and the helmet features a calendar marked "GAME OVER" at the bottom, the words "Brain Dead", and a painted image of an eight ball. The infrared sight lights up.

English has autographed the inside of the breastplate, with the inscription "Stay Cool 2023". This lot exhibits some minor scratches and scuffing, but otherwise remains in very good condition.

**Estimate: £5,000 - 10,000**



**20**  
**Ash William's (Bruce Campbell) Distressed Costume m**  
**Army Of Darkness (1992)**

Ash William's (Bruce Campbell) distressed medieval costume from Sam Raimi's comedy-horror sequel Army of Darkness. Ash wore his medieval costume while battling his evil clone in a windmill, and when he arrived at the location of the Necronomicon.

The costume comprises a knee-length knit cape made of heathered grey wool; a double-breasted knit shirt made of cotton, which features a flap that closes over with snap buttons; and a pair of brown cotton trousers. Both the shirt and trousers are distressed with stage blood, mud stains and general tears. The cape is held in place with a modern pin, and does not include the original cape pin.

**Estimate: £5,000 - 10,000**

**21**  
 Arthur's (Dudley Moore)  
 Licence Plate M  
**Arthur (1981)**

Arthur's (Dudley Moore) licence plate from Steve Gordon's romantic comedy Arthur. A customised licence plate spelling out his name adorned Arthur's Rolls-Royce Silver Wraith limousine as his chauffeur, Bitterman (Ted Ross), drove him around New York.

Arthur was nominated for four Academy Awards, including Best Screenplay and Best Actor for Moore, while it won in the Best Original Song category, with John Gielgud winning Best Supporting Actor Oscar.

The licence plate is made of painted fibreboard.  
 Dimensions:  
 30.75 cm x 15.5 cm x 0.5 cm (12.25" x 6" x 0.25")

**Estimate: £5,000 - 10,000**



**22**  
 Ash Williams' Costume and Chainsaw  
**Ash Vs Evil Dead (T.V. Series, 2015-2018)**

Ash Williams' (Bruce Campbell) costume and chainsaw from Ash vs Evil Dead. Ash first donned his blue chambray costume and chainsaw weapon at the end of the premiere episode "El Jefe" (101) as he fought his possessed neighbour. He continued to wear the blue shirt and brown trousers combo off and on throughout the rest of the series, as well as his chainsaw weapon as he battled the dead and demons alike.

This costume consists of one long-sleeve blue cotton chambray shirt with black buttons on the lower back; a brown faux leather and webbed nylon shotgun harness; black elastic braces; a brown leather belt; brown cotton chambray trousers; black elastic sock garters; and dark brown leather lace-up boots. The shirt, belt, trousers, and shoes all feature hand-marked labels for "Raycho," with the shirt marked specifically for "S3 No Padding For Breakdown Only No. 4." This chainsaw is made of resin and metal pieces with a cotton twine pull cord and a moveable flipswitch on the outside. It has a foam insert for where the chainsaw attached to Ash's prosthesis. It is accompanied by one rubber teeth chain, a metal black blade, and three acrylic blades with one marked "Stunt Rehearsal" in white paint. Also included is a blue rubber production tag hand-marked with "Main Original Narrow Body." Production intentionally distressed this chainsaw to appear well-used. This lot exhibits pulled threads, frayed fibres, discolouration, chipped paint, and a buildup of grime. Dimensions: (chainsaw) 81.5 cm x 28 cm x 25.5 cm (32" x 11" x 10")

**Estimate: £8,000 - 16,000**



**23**  
 SFX Necronomicon Ex-Mortis M  
**Ash Vs Evil Dead (T.V. Series, 2015-2018)**

An SFX Necronomicon Ex-Mortis from the horror-comedy TV series Ash vs Evil Dead. The iconic Necronomicon first appeared in Sam Raimi's 1981 horror The Evil Dead, and was used in the series by Ash (Bruce Campbell) to accidentally summon the Kandarian Demon. This SFX version was used for scenes in which something went into, or came out of, the mouth which forms part of the book's cover.

The book is made of resin and wood, with a silicone cover painted to look like ancient leathery flesh. The back of the book is open, allowing the performer to push their hand through the mouth. The silicone cover has a sticky sheen and there is some wear to the paintwork. Dimensions: 29 cm x 23 cm x 4.5 cm (11.5" x 5" x 1.75")

**Estimate: £5,000 - 10,000**



The back of the book is open, allowing the performer to push their hand through the mouth

**24**  
 Stunt Kandarian Dagger  
**Ash Vs Evil Dead (T.V. Series, 2015-2018)**

A stunt Kandarian Dagger from the television series Ash vs Evil Dead. The ancient Kandarian Dagger appeared throughout the series, including when Ruby Knowby (Lucy Lawless) used it to cut the skin binding off the Necronomicon, and later when Ash Williams (Bruce Campbell) taped it to his "boomstick" as a makeshift bayonet.

The Kandarian Dagger was designed by special effects artist Tom Sullivan for Sam Raimi's The Evil Dead, in which Ash rediscovered it in the Knowby cabin. Having since appeared in Evil Dead II, as well as video game and comic book spin-offs despite never being named in the films, the Dagger has since become amongst the most recognizable weapons in Raimi's franchise.

This stunt foam knife features a thin jagged blade painted dark grey to resemble obsidian and set into a textured snake-patterned handle painted the colour of bone. The dagger exhibits intentional distressing by production to appear ancient and well-used with nicks in the blade and grimy discolouration to the handle. Dimensions: 44.5 cm x 7.75 cm x 6.5 cm (17.5" x 3" x 2.5")

Additional Provenance: STARZ Certificate of Authenticity.

Edged, bladed or blunt object; see notice on Blades in the Buyer's Guide.

**Estimate: £5,000 - 10,000**





**25**  
**Mini Me's (Verne Troyer) Prison Costume from Austin Powers In Goldmember (2002)**

A Mini Me (Verne Troyer) prison costume display from Jay Roach's spy-comedy sequel Austin Powers in Goldmember. Mini Me wore his prison costume while serving time behind bars with Dr Evil (Mike Myers).

The costume was custom-made for Troyer and comprises a purple cotton paisley-patterned bandana; a blue cotton shirt with a "00001/8" prisoner badge stitched onto the left pectoral; a pair of blue braces; a pair of blue denim trousers; and a pair of blue suede Hush Puppies loafers (size "UK 9.5N").

"#1" is handwritten in black marker pen inside the shirt's collar, and also in silver marker pen on the inside of both the trousers' waistband and the right loafer. A costume label stitched inside the trousers has "Verne Troyer" handwritten on it in blue ink.

The costume is displayed on a custom-made stand with a wooden base, a plaque bearing the film's title, and an acrylic rod to support the foam mannequin. A metal halo extends from the top of the mannequin, on which the bandana is displayed. A certificate of authenticity accompanies the lot.

**Estimate: £4,000 - 8,000**



**26**  
**Michael J. Fox, Christopher Lloyd and Cast-autographed ZigZag Commercial Poster for Back To The Future (1985)**

A cast-autographed ZigZag commercial poster for Robert Zemeckis' sci-fi adventure Back to the Future. The poster features an illustration of Marty McFly (Michael J. Fox) and the flaming DeLorean by famed artist Drew Struzan.

The poster is autographed in blue ink by Michael J. Fox (Marty McFly), Christopher Lloyd (Dr. Emmett Brown), Lea Thompson (Lorraine Baines), Claudia Wells (Jennifer Parker), singer Huey Lewis, Tom Wilson (Biff Tannen), Frances Lee McCain (Stella Baines), James Tolkan (Mr. Strickland), Billy Zane (Match), Donald Fullilove (Goldie Wilson), and director of photography Dean Cundey. Dimensions: 101.5 cm x 68.5 cm (40" x 27")

The autographs in this lot have been professionally authenticated by expert Garry King; see notice in the Buyer's Guide.

**Estimate: £1,000 - 2,000**

**27**  
**Marty McFly's (Michael J. Fox) Radiation Suit with Hood from Back To The Future (1985)**

Marty McFly's (Michael J. Fox) radiation suit with hood from Robert Zemeckis' sci-fi adventure Back to the Future. Marty wore his radiation suit while travelling back in time to the year 1955. He later donned it again as "Darth Vader from Planet Vulcan" to scare his father George McFly (Crispin Glover) into asking his mother Lorraine Baines (Lea Thompson) to the Enchantment Under the Sea dance.

The Back to the Future trilogy has remained immensely popular since the first film's release almost 40 years ago, spawning an animated series, theme-park attractions and a stage musical.

This costume consists of a fluorescent yellow Tyvek jumpsuit (marked "X-Large") with a matching yellow hood made of canvas and polyester. The suit features a zip down the front, Velcro fasteners on the wrists, and bright orange triangular inserts on the ankles. The hood includes an orange strip along the top and metal snaps around the face, which open to attach an air filtration mask (this is not included). The suit displays several dirt marks, notably around the ankles, and patches of minor wear to the Tyvek material.

**Estimate: £10,000 - 20,000**



Cinematic / Alamy Stock Photo



Maximum Film / Alamy Stock Photo





**28**  
**Marty McFly's (Michael J. Fox) Screen-matched 2015 Resizing Jacket m**  
**Back To The Future Part II (1989)**

Marty McFly's (Michael J. Fox) screen-matched 2015 jacket from Robert Zemeckis' sci-fi adventure sequel Back to the Future Part II. Doc Brown (Christopher Lloyd) took Marty to the year 2015 and gave him a futuristic ensemble to help him blend in, including a self-drying, auto-resizing jacket. The placement of the rubber nodules on the chest match the jacket to the scene in which Marty and Doc return to their car, only to find that the police have discovered Jennifer's (Elisabeth Shue) unconscious body.

Custom-made for the production, the 'high tech' garment is made from red nodule textured rubber, with several dark grey and black components made from a combination of latex, urethane and foam. Two square-shaped pockets with short flaps adorn the front, and the jacket features a stand-up collar. The sleeves are gathered at the top and halfway down, suggesting this version was worn after the auto-resizing function was activated. Two static red buttons are located on the front of the ribbed waistband.

This particular jacket has been sympathetically restored by Tom Spina Designs Inc. Over time the materials had stiffened, requiring the Tom Spina team to repair several cracks and apply paint touch-ups. They also added three inserts into the chest and sleeves to help the jacket maintain its shape.

The lot is mounted on a custom-built padded display, with an angled wooden stand situated at the back. It exhibits signs of wear and damage due to the fragile nature of the materials, including small holes and cracks on the sleeves. Due to the fragile nature of the jacket, it should be handled with care. Dimensions (displayed): 69 cm x 123 cm x 17.5 cm (27.25" x 48.5" x 7")

Special shipping required; see special shipping notice in the Buyer's Guide.

**Estimate: £60,000 - 120,000**

Two static red buttons are located on the front of the ribbed waistband.



Alistar Picture Library Ltd / Alamy Stock Photo





**29**  
 Marty McFly's (Michael J. Fox) Hoverboard α  
**Back To The Future Part II (1989)**  
**/Back To The Future Part III (1990)**

Marty McFly's (Michael J. Fox) hoverboard from Robert Zemeckis' Back to the Future: Part II and its sequel, Part III. McFly first obtained his hoverboard from a young girl in the year 2015 to escape from Griff Tannen (Thomas F. Wilson) and his gang, and continued to use it throughout both films. The hoverboard became McFly's signature accessory and remains among the most beloved hi-tech innovations associated with the franchise.

Two primary styles of hoverboards were made for production: wood boards for effects work, including shots of the actor riding the board, and lightweight foam boards typically used for shots of the performer carrying the board. This hoverboard - a rare complete example originating with a production team member - is constructed primarily of rigid lightweight foam painted pink and given a photo-print finish on the top and bottom (as opposed to the lenticular print used on some boards).

The top features the word "HOVERBOARD," Mattel logos, foot-pad and fuzzy pink foot-strap (which are frequently missing from Mattel board props), zig-zagging pink and green fastening strips, and a hole in the front from where Marty would have removed the handle. The bottom features plastic detailing including two silver-colour hover pads.

This hoverboard exhibits wear from use and age, including adhesive residue around the fastening strips, cracks in the foam, and paint chipping throughout with the most extensive paint chipping around the hover pads.  
 Dimensions: 71.25 cm x 20.5 cm x 6.5 cm (28" x 8" x 2.5")

**Estimate: £80,000 - 160,000**

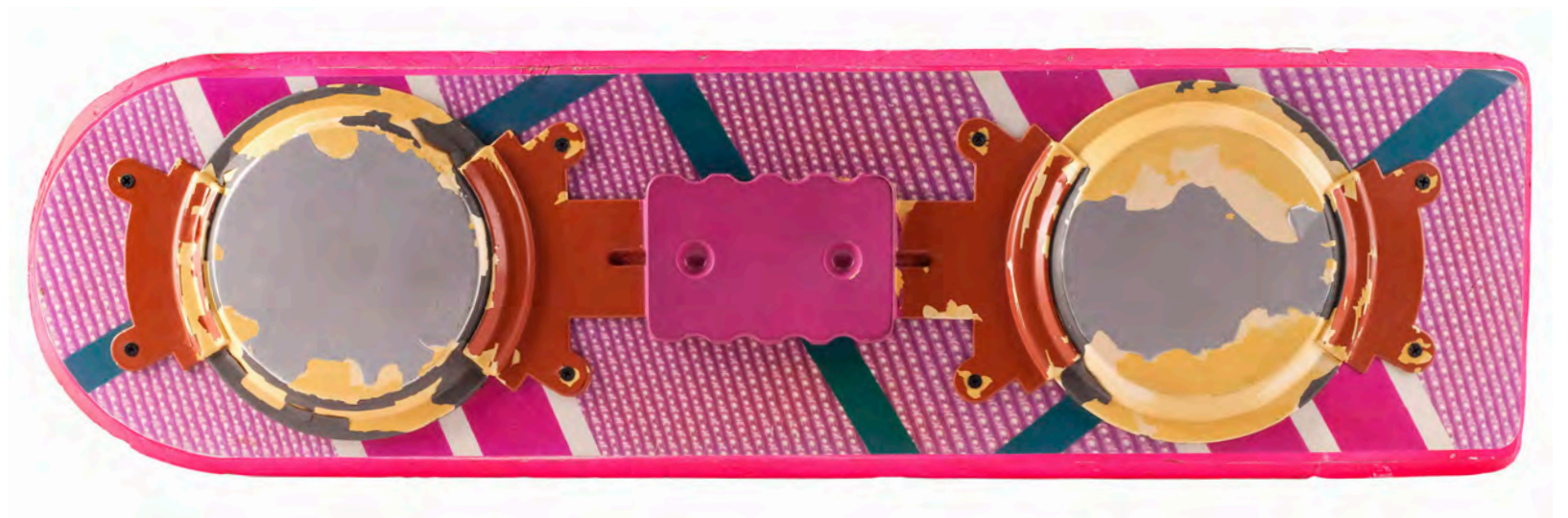

### 30 Marty McFly (Michael J. Fox) Self-fitting Jacket Costume Designs m Back To The Future Part II (1989)

Marty McFly (Michael J. Fox) resizing jacket costume designs from the production of Robert Zemeckis' sci-fi adventure sequel Back to the Future Part II. Doc Brown (Christopher Lloyd) transported Marty to the year 2015 and gave him a futuristic ensemble to help him blend in, including a self-drying, auto-resizing jacket.

The film's visual effects art director, John Bell, (Jurassic Park, Starship Troopers) hand-painted one of the concept designs for the jacket in watercolours. He has signed the piece in the bottom left corner, and dated it "3.89".

Bell worked from original sketches by costume designer Joanna Johnston, three pages of which are also included in the lot. These sketches are rendered in pencil and ink on white paper, except for one that is printed, with hand-drawn red pencil embellishments to the jacket. They feature four different poses and angles of Marty, with annotations. The drawing labelled "Marty" is partially coloured and features sketches of specific jacket components. The three pages of sketches are stamped "Designed by Joanna Johnston". Dimensions (one piece): 40.5 cm x 29.75 cm (16" x 11.75")

Estimate: £3,000 - 6,000



### 31 "Youth Jailed" USA Today Newspaper Cover n Back To The Future Part II (1989)

A USA Today newspaper cover headlined "Youth Jailed" from Robert Zemeckis' Back to the Future Part II. After Doc Brown (Christopher Lloyd) convinced him to come back to the future for the benefit of his future children, Marty McFly (Michael J. Fox) read a paper that detailed his own arrest.

Upon release, Back to the Future Part II became the third-highest-grossing film of 1989 and earned an Academy Award® nomination for Best Visual Effects. It is today considered among the greatest sequels in cinema history, particularly for its prescient depiction of then-futuristic, but now-modern, technology.

This newspaper cover, with a colour-printed image of McFly being arrested by police headlined "Youth Jailed: Martin McFly Junior Arrested for Theft," dated "October 22, 2015," and labelled "Hill Valley Edition" on the front, originated from a Universal employee. It features unrelated filler stories and advertisements on the reverse, while its interior pages are blank. The cover exhibits a yellowish-brown hue due to age, holes along its edges from printing, and a horizontal fold line through its centre.

Dimensions: 35 cm x 28.75 cm (13.75" x 11.25")

Estimate: £5,000 - 10,000



### 32 "Gang Jailed" USA Today Newspaper Cover m Back To The Future Part II (1989)

A USA Today newspaper cover headlined "Gang Jailed" from Robert Zemeckis' sci-fi adventure sequel Back to the Future Part II. A newspaper was seen after Marty McFly's (Michael J. Fox) hoverboard crashed while visiting the future year of 2015. According to Doc Brown (Christopher Lloyd), it was proof that history was being altered for the benefit of McFly's children.

Dated "October 22, 2015," this newspaper consists of two printed outer pages and two blank interior pages printed on newsprint stock. The front cover features the headline "Gang Jailed, Hoverboard Rampage Destroys Courthouse" and an image of Griff Tannen (Thomas F. Wilson) being arrested. The paper has some minor discolouration and light edge wear. Dimensions (unfolded): 55.5 cm x 35 cm x 2 cm (21.25" x 13.75" x 0.75")

Estimate: £4,000 - 8,000

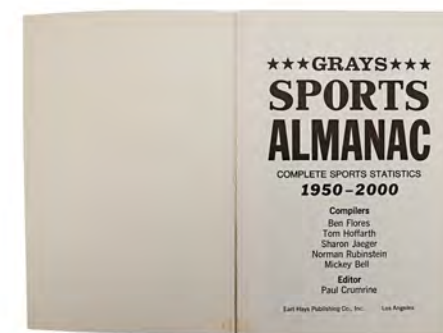

### 33 Grays Sports Almanac m Back To The Future Part II (1989)

A Grays Sports Almanac from Robert Zemeckis' sci-fi adventure sequel Back to the Future: Part II. Purchased by Marty McFly (Michael J. Fox) while exploring Hill Valley in 2015, the Grays Sports Almanac became a central plot point when it was discovered by an elderly Biff Tannen (Thomas F. Wilson) who decided to change the course of history by gifting it to his younger self in the past.

Featuring custom-made front and back covers and a cover page noting statistics between 1950 and 2000, the book actually contains statistics from the year 1984. It also has numerous repeating pages of statistics and notably features the "19 to 17" UCLA football score referenced by Biff when he demonstrates the Almanac's accuracy. This prop shows minor wear to the paper due to production use and age, but it remains in good condition.

Dimensions: 15 cm x 22 cm x 1 cm (6" x 8.75" x 0.25")

Estimate: £8,000 - 16,000

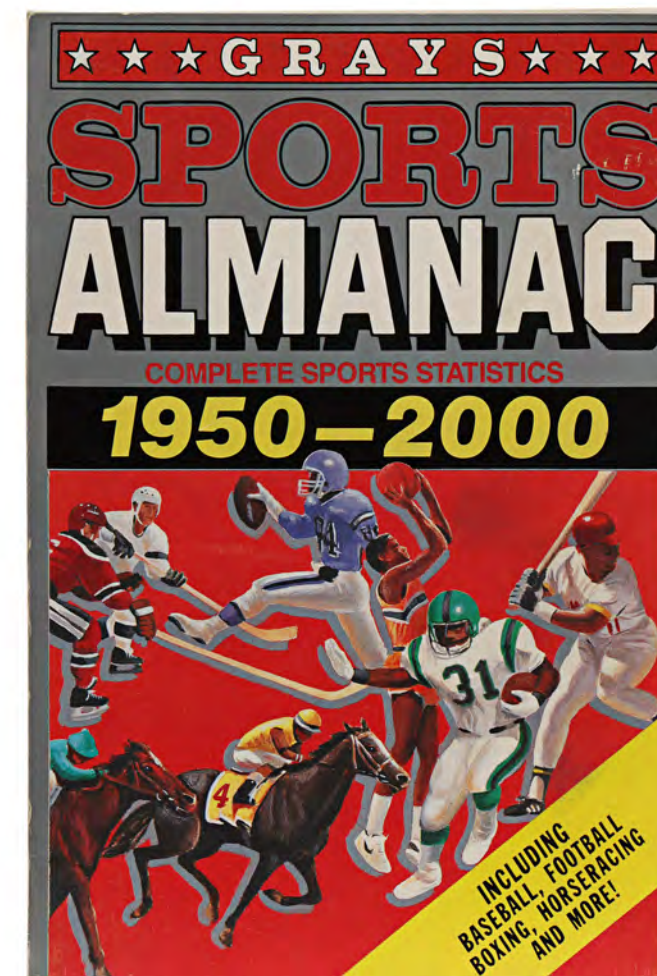



**34**  
**SFX Spinning Train-Wrecked 2015 DeLorean Licence Plate** Ω  
**Back To The Future Part III (1990)**

An SFX spinning train-wrecked 2015 DeLorean licence plate from the production of Robert Zemeckis' Back to The Future Part III. Doc Brown's (Christopher Lloyd) DeLorean was the signature vehicle in the Back to the Future trilogy, used throughout each film by Brown and Marty McFly (Michael J. Fox) as they scrambled to save history. In the climactic sequence, Marty arrived back in 1985 and narrowly avoided death by escaping the DeLorean time machine when an oncoming Alco S6 locomotive destroyed it. In a shot created by Industrial Light & Magic (ILM), the DeLorean's licence plate was seen spinning on the train track before coming to a halt on the ground within the wreckage in an homage to a similar shot seen in the first Back to The Future.

This heavily-distressed version of the plate was designed to appear within the debris on the train tracks and for filming the spinning sequence, but was ultimately not seen in the final cut of the film. A cleaner and less-distressed version of the licence plate was seen spinning in the film.

The steel plate features foil decals including a barcode, the year "2015," and the letter "L," which would have been part of the word "California." It has been heavily distressed to resemble the damage inflicted by the train, with the shape warped, the orange paint finish partially removed, and signs of heat damage. Two small, square pieces of metal have been welded onto the back, allowing the plate to be rigged on a SFX rig to achieve the special spinning effect. There is a welding spot mark on the rear bottom left corner and some edges of the foil decals have become unstuck over time. The plate and foil exhibit signs of rusting, and the steel exhibits minor surface scratches.

Dimensions: 15 cm x 28.5 cm x 5 cm (6" x 11.25" x 2")

**Estimate: £15,000 - 30,000**



Two small square pieces of metal have been welded onto the back, allowing the plate to be rigged on a SFX rig to achieve the special spinning effect



**35**  
**Clara Clayton's (Mary Steenburgen) Train Sequence Dress** †Δ  
**Back To The Future Part III (1990)**

Clara Clayton's (Mary Steenburgen) train sequence dress from Robert Zemeckis' sci-fi adventure sequel Back to the Future Part III. Clara wore her costume towards the end of the film, when she climbed onto the locomotive to declare her love for Doc Brown (Christopher Lloyd), who was using the train, along with Marty (Michael J. Fox), to push the DeLorean so it could reach 88 mph and return to 1985.

The dress comprises a fitted plum-and-magenta cotton-blend long-sleeved top with 13 flower-shaped buttons, a cream frill collar, and a matching pleated skirt. The skirt features five cotton-blend layers of varying shades of purple, which are attached to a fitted black button-up underskirt marked "Short", a lace-up black mesh lining on the interior, and a hook-and-eye closure. There are extra layers at the back of the skirt to create a bustle effect. The dress comes with three wardrobe tags reading "W.22/23 2PC", "Mary Steenburgen -Clara- -BTTF3-" and "Back to the Future 3". The dress exhibits tears to the back of the skirt, visible colour-fading from age, and one of the buttons is damaged.

**Estimate: £8,000 - 16,000**

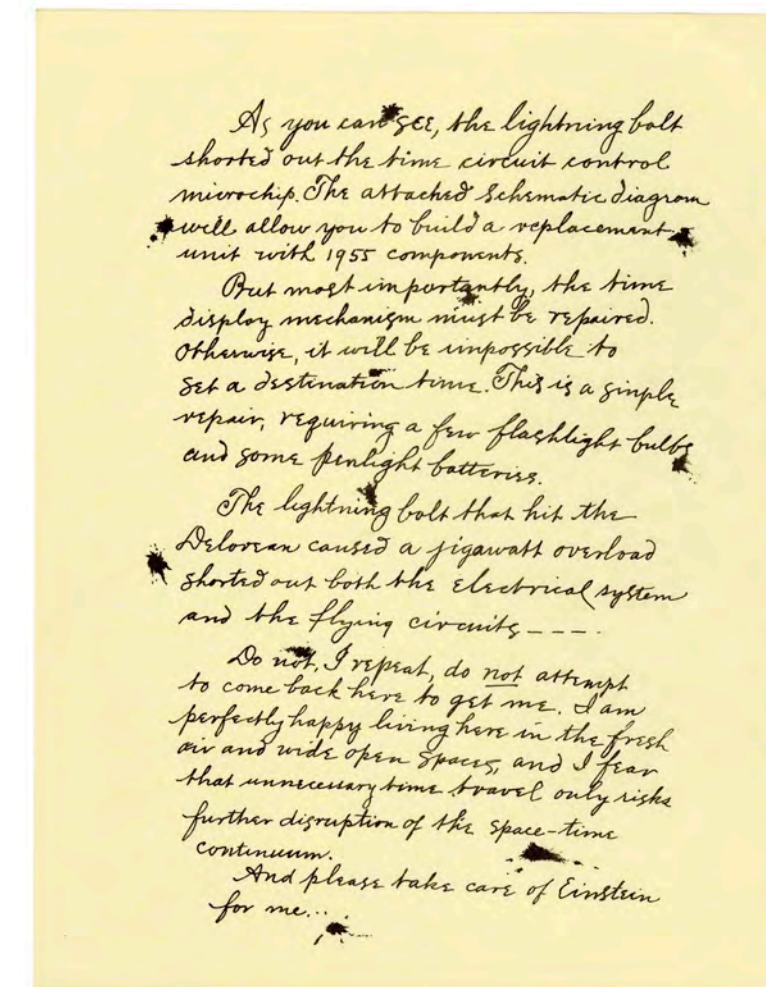

**36**  
**Page from Doc's (Christopher Lloyd) 1885 DeLorean Repair Letter to Marty (Michael J. Fox)** Ω  
**Back To The Future Part III (1990)**

A page from Doc's (Christopher Lloyd) 1885 DeLorean repair letter to Marty (Michael J. Fox) from Robert Zemeckis' Back to the Future Part III. In 1955, McFly discovered a letter sent by 1885-era Doc Brown on how to fix the DeLorean, then read it to 1955-era Brown.

This paper letter features cursive text printed in black ink. Although the text varies slightly from what is spoken and seen in the final cut, it contains several of the same phrases and elements McFly reads out loud. The letter exhibits several production-made ink blotches and minor worn corners. Dimensions: 28 cm x 21.5 cm (11" x 8.5")

**Estimate: £4,000 - 8,000**

No lot 37  
No lot 38



**39**  
Static Penguin Commando  $\Omega$   
Batman Returns (1992)

A static Penguin Commando from Tim Burton's Batman Returns. Once his plan to kidnap the children of Gotham began to fold, the Penguin (Danny DeVito) released his missile-wielding Penguin Commandos to destroy Gotham. Production used static penguin puppets to fill out the crowd of live birds, many of whom would not stay still for the duration of the sequence.

This foam penguin is moulded around metal rods and painted black, white, purple, and silver-colour to appear as if it is wearing a helmet and harness. It is affixed via metallic loops on the back with a resin rocket painted silver-colour with red and white stripes. The penguin exhibits cracking around its legs and discolouration around the helmet and fins from production use and age.  
Dimensions: 20.5 cm x 33 cm x 51 cm (8" x 13" x 20")

**Estimate: £6,000 - 12,000**



**40**  
Batman's (Michael Keaton) Super-Batarang  $\Omega$   
Batman Returns (1992)

Batman's (Michael Keaton) Super-Batarang from Tim Burton's Batman Returns. Batman used his Super-Batarang to dispatch Penguin's (Danny DeVito) henchmen during the Gotham Christmas Tree lighting ceremony.

Designed by illustrator Tim Flattery, this cast resin Super-Batarang is hand-painted black with simulated buttons, including one red button and a silver-colour adhesive screen. The Batarang exhibits a chip in the red button, peeling to the adhesive screen, and a bend in the tip of the left wing through which a metal armature protrudes. Dimensions: 35.75 cm x 11.5 cm x 1.5 cm (14" x 4.5" x 0.5")

**Estimate: £4,000 - 8,000**

**41**  
Batman's (Val Kilmer) Batsuit Cowl and Hero Chest Emblem  $\Omega$   
Batman Forever (1995)

Batman's (Val Kilmer) Batsuit cowl and hero chest emblem from Joel Schumacher's superhero sequel Batman Forever. Batman wore his Batsuit while confronting Two-Face (Tommy Lee Jones) and The Riddler (Jim Carrey).

Designed by Bob Ringwood, the cowl is more durable and wearer-friendly than previous incarnations. It is made of cast foam rubber, which is finished in Batman's matt black colour scheme. Velcro is fitted at the edges to secure the cowl to the rest of the Batsuit, and across the niche on the chest for the attachment of the chest emblem.

The emblem is made of resin and metal, and was created as a three-piece assembly to give the design a more three-dimensional appearance. The outer ring and bat symbol are finished in black, while the metal backing plate is finished in metallic gold paint. The lot is displayed on a stand comprising an acrylic rod and a metal support bar.  
Dimensions: 21.5 cm x 38.5 cm x 63.5 cm (8.5" x 15.25" x 25")

**Estimate: £20,000 - 40,000**



**42**  
The Riddler's (Jim Carrey) Question-Mark Cane  $\Omega$   
Batman Forever (1995)

The Riddler's (Jim Carrey) question-mark cane from Joel Schumacher's Batman Forever. The Riddler wore his green leotard and twirled his iconic question-mark cane from the moment he teamed up with Two-Face (Tommy Lee Jones), to his destruction of the Batcave, when he used the cane as a remote trigger for his powerful bombs.

Batman Forever held the title of the all-time highest opening-weekend gross for two years and the largest opening weekend of a Warner Bros. film for six years. Costume designers Bob Ringwood and Ingrid Ferrin drew inspiration from the original Dick Sprang comic artwork of the character, as well as the attire worn by Frank Gorshin as the Riddler in the Batman television series. They added the question-mark cane, which became a fixture in the comics' depiction of The Riddler soon after.

This cane is made of gold-colour metalized resin with a metal tip and core. It features a question mark symbol as a handle, with a spiral pattern up the shaft. It exhibits some scuffing and paint flaking from use and age. Dimensions: 97 cm x 19 cm x 5 cm (38" x 8" x 2")

**Estimate: £8,000 - 16,000**



No lot 43

44

**Batman (George Clooney) and Robin (Chris O'Donnell) Utility Belts m**  
**Batman & Robin (1997)**

Batman (George Clooney) and Robin (Chris O'Donnell) utility belts from Joel Schumacher's superhero sequel Batman & Robin. Batman and Robin wore their belts while in their costumes, fighting crime.

The belts are made of dark blue rubber and feature a bat emblem and a bird emblem, respectively. They have fabric straps at the back (side release clips missing) so they can be fastened to the actor.

**Estimate: £5,000 - 10,000**



**45**  
**Stunt Batarang and Batcave Worktable Batarang tΔ**  
**Batman Begins (2005)**

A stunt Batarang and a Batcave worktable Batarang from Christopher Nolan's superhero film Batman Begins. Batman/Bruce Wayne (Christian Bale) used Batarangs to fight Gotham's villains throughout the movie.

The stunt version was created for action scenes. The worktable version was designed for the scene in which Wayne is seen crafting a Batarang in the Batcave.

The stunt version is made of dense rubber and painted with a bronze finish. It is horizontally foldable via two metal hinges at the centre of its rear side. The worktable version is made from resin with a black paint finish. Each Batarang is presented on a display, which comprises a black-painted wooden base and metal ledge. Dimensions (worktable batarang): 19.5 cm x 7 cm x 0.75 cm (7.75" x 2.75" x 0.25")

**Estimate: £4,000 - 8,000**

46

**Heath Ledger Autographed Photo m**  
**The Dark Knight (2008)**

An autographed photo of Heath Ledger as the Joker from Christopher Nolan's superhero sequel The Dark Knight.

The announcement that Ledger would play one of popular culture's most notorious villains at first seemed surprising, given the Australian actor was previously best known for romantic and heroic roles. But Ledger proved to be powerfully compelling in the part, and his Joker remains regarded as the character's best cinematic incarnation to date. Ledger sadly died just a few months after filming, but won several posthumous awards, including the Oscar for Best Supporting Actor.

Nolan and makeup artist John Caglione drew particular inspiration for the Joker's look from the paintings of Francis Bacon. The photograph depicts the villain with his iconic white makeup and elaborate red lipstick, which was applied by Ledger himself, as he wanted the character to feel more realistic. It is autographed by Ledger in white marker, and inscribed "To Jon Big Smile!"

Dimensions: 30.5 cm x 21 cm (12" x 8.25")

The autographs in this lot have been professionally authenticated by expert Garry King; see notice in the Buyer's Guide.

**Estimate: £4,000 - 8,000**

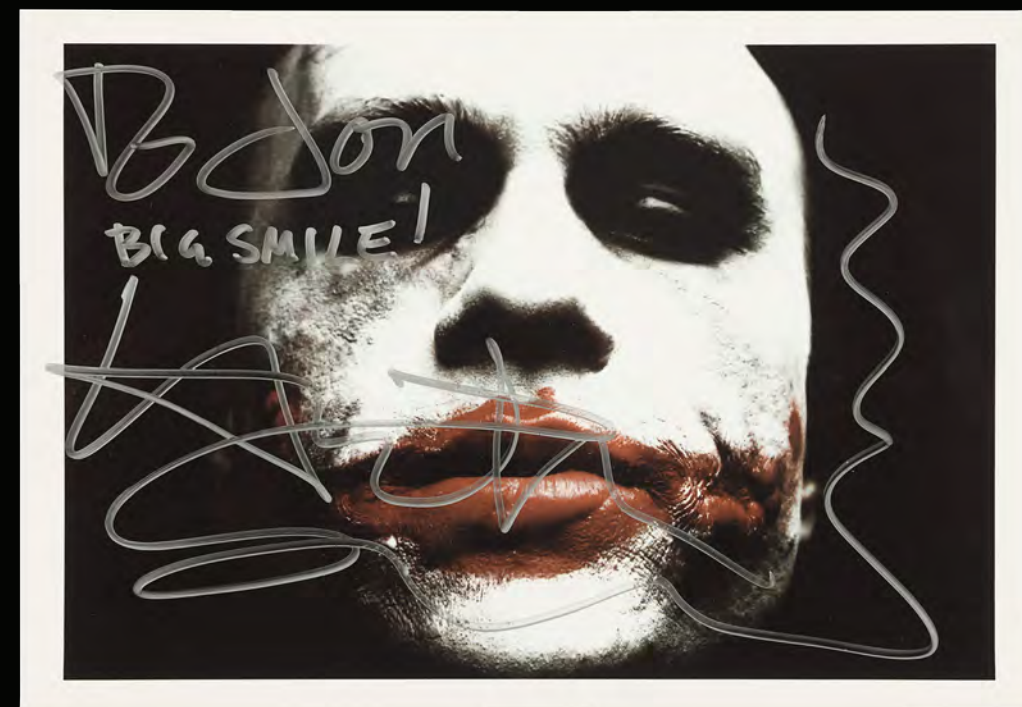

47

**Heath Ledger Autographed Photo m**  
**The Dark Knight (2008)**

A Heath Ledger-autographed photo from Christopher Nolan's superhero sequel The Dark Knight. Ledger won a posthumous Oscar for his iconic performance as the villainous Joker, Batman's greatest foe.

The photograph is taken from a scene in the film during which Joker has been apprehended by the police and is being interrogated by Batman (Christian Bale). Ledger has autographed the image in black ink, along with the inscription, "To Kiera, Big smile!". Ledger passed away in January of 2008, and the film was released posthumously.

Dimensions: 26 cm x 21 cm (10.25" x 8.25")

The autographs in this lot have been professionally authenticated by expert Garry King; see notice in the Buyer's Guide.

**Estimate: £3,000 - 6,000**





**48**  
**Judah Ben-Hur's (Charlton Heston)**  
**Costume Test Tunic**  $\Omega$   
**Ben-Hur (1959)**

Judah Ben-Hur's (Charlton Heston) costume test tunic from William Wyler's Ben-Hur. In the film, Ben-Hur wore one of his tunics when he reunited with his childhood friend, Messala (Stephen Boyd).

A still of a costume test fitting from the production shows Heston wearing a tunic of a similar style to Ben-Hur's Messala scene tunic. This tunic may be the exact one seen in that costume test fitting photograph, but this cannot be conclusively confirmed as it was modified and dyed green with additional stitching applied over the cuff, hem, and shoulders for a separate production after production on Ben-Hur.

Ben-Hur won 11 of the 12 Academy Awards<sup>®</sup> it was nominated for as well as three Golden Globe Awards<sup>®</sup>. In 2004, it was selected for preservation by the National Film Registry in 2004. The chariot race sequence remains one of the most famous sequences in cinema history.

This woven cotton tunic with gold-colour embroidery features a Metro Goldwyn Mayer (MGM) label on the inside collar as well as a makers label from "Western Costume Co." marked for "Charlton Heston" numbered "2350-1." In addition to its green hue, it exhibits discolouration, some fading, and pulled threads from wear and age.

**Estimate: £4,000 - 8,000**



**49**  
**Blade's (Wesley Snipes) Metal Daywalker Sword**  $\Omega$   
**Blade (1998)**

Blade's (Wesley Snipes) metal daywalker sword from Stephen Norrington's Blade. The half-human, half-vampire carried his signature sword in multiple scenes throughout the film and wielded it as he battled Deacon Frost (Stephen Dorff) after he'd become the avatar of the supreme blood god La Magra.

Originally sourced from a member of the film's prop department, this sword features an aluminium blade inset into a ribbed, machined aluminium grip. Finished in black and silver-colour paint, the round grip is flattened on one side, features vertical grooves that separate the ribbed rings, and is decorated with ornate embossed vampiric glyphs at the top and bottom. The grip has a neck collar, as seen in the film, though it has no functionality and a notch that prevents it from rotating fully. This sword exhibits some scuffing to its finish, as well as some residue and discolouration along the blade and grip. Dimensions: 90.25 cm x 5 cm x 5 cm (35.5" x 2" x 2")

Blade was dulled by production.

Edged, bladed or blunt object; see notice on Blades in the Buyer's Guide.

**Estimate: £12,000 - 24,000**





**50**  
**Light-up Fluorescent Street Umbrella †**  
**Blade Runner (1982)**

A light-up fluorescent street umbrella from Ridley Scott's sci-fi classic Blade Runner. Set in 2019 Los Angeles, the film depicts a dystopian rain-soaked city whose inhabitants carried umbrellas, and replicant Zhora (Joanna Cassidy) used them as cover while fleeing from Rick Deckard (Harrison Ford). This lot originated from the family of Blade Runner archivist Geoff Hutchins.

This umbrella comprises a red nylon canopy painted black on the exterior; an acrylic shaft encasing a fluorescent tube; and a black enamel-and-resin ball handle with a black rubber plug cable protruding from it. The umbrella is presented on a custom wooden display plinth, which is painted black and features an acrylic plaque, on which the film's title and a description of the piece are engraved. The umbrella's shaft lights up when it is connected via a cable that runs from the bottom of its handle to a 12V power supply concealed within the plinth, and activated using a switch on the plinth. The lot exhibits paint wear, chips to the enamel handle, and glue residue from production use. Dimensions: 131 cm x 105 cm x 105 cm (51.5" x 41.25" x 41.25")

Contains electronics; see electronics notice in the Buyer's Guide.

**Estimate: £6,000 - 12,000**

**51**  
**Editor Terry Rawlings' Pair of Deckard**  
**(Harrison Ford) Apartment Glass**  
**Whiskey Tumblers M**  
**Blade Runner (1982)**

A pair of glass whiskey tumblers from Ridley Scott's sci-fi classic Blade Runner. Rick Deckard (Harrison Ford) sipped whiskey from a glass tumbler while viewing Esper tapes in his apartment. This lot comes from the estate of Terry Rawlings, the supervising editor on the film.

These iconic glasses have a distinctive, angular body, with an octagonal base and rim. Designed in 1973 for the Cibi Collection by Cini Boeri, they were produced by Italian glassware company Arnolfo di Cambio®, whose logo is discernible on the base of each glass. Scott selected the Cibi glasses for use in the film because of their striking, futuristic design. Ergonomically designed, they are pleasant to grip and have a robust and weighty feel. Dimensions: 9.25 cm x 8.5 cm x 8.5 cm (3.75" x 3.25" x 3.25")

**Estimate: £4,000 - 8,000**

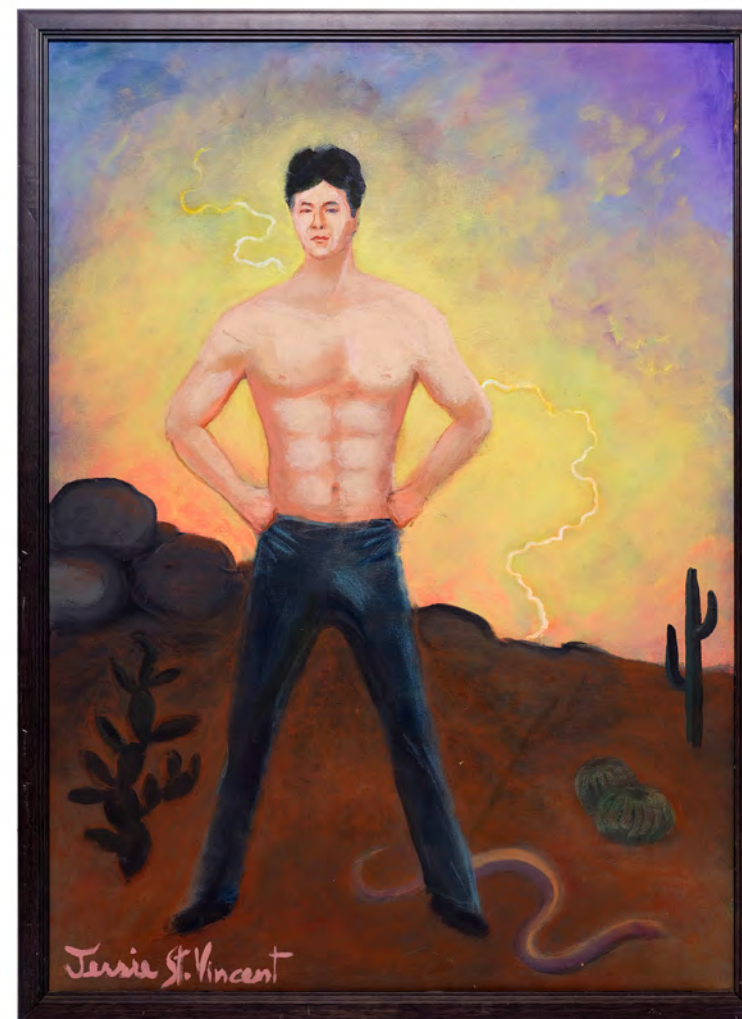

**52**  
**Jessie St. Vincent's (Melora Walters) Screen-matched**  
**Framed Hand-painted Portrait of Dirk Diggler**  
**(Mark Wahlberg) †**  
**Boogie Nights (1997)**

Jessie St. Vincent's (Melora Walters) screen-matched, framed, and hand-painted portrait of Dirk Diggler (Mark Wahlberg) from Paul Thomas Anderson's Boogie Nights. Distinctive shading and paint markings screen-match this portrait to when Diggler showed Amber Waves (Julianne Moore) around his new mansion and pointed out the painting done of him by St. Vincent, who was already working on another one.

The critically-acclaimed Boogie Nights is widely considered one of Anderson's best films and one of the greatest films of all time. It was nominated for three Academy Awards, including Best Original Screenplay for Paul Thomas Anderson, Best Supporting Actress for Julianne Moore, and Best Supporting Actor for Burt Reynolds.

This painting depicting Diggler shirtless in a desert, surrounded by cacti and a snake, with the character name "Jessie St. Vincent" written in the bottom left corner is rendered in oil on canvas. It comes mounted inside a custom wooden frame. The frame exhibits some scuffing. Dimensions: 112 cm x 82.75 cm x 2.75 cm (44" x 32.5" x 1")

Sold without copyright; see notice in the Buyer's Guide.

**Estimate: £8,000 - 16,000**

**53**  
**US One-Sheet Poster †**  
**Breakfast At Tiffany's (1961)**

A US One-Sheet poster from the release of Blake Edwards' romantic comedy Breakfast at Tiffany's. This poster, featuring Robert McGinnis' artwork, is arguably one of the most famous designs of the 1960s, featuring Holly Golightly (Audrey Hepburn) in her iconic black Givenchy gown, cigarette holder in hand and cat on her shoulders.

The poster is conservation linen-backed with sympathetic restoration around the border, on the dress, on the white areas and on various other smaller areas. It remains in very fine condition. Dimensions: 104 cm x 69 cm (41" x 27")

**Estimate: £5,000 - 10,000**





**54**  
Italian Four-Foglio m  
**Breakfast At Tiffany's (1961)**

An exceptionally rare Italian Four-Foglio poster from the promotion of Blake Edwards' classic romantic comedy *Breakfast At Tiffany's*. Written by Truman Capote and starring Audrey Hepburn, this film set a very high bar for the rom-com genre while making Hepburn an international style icon with the help of that Givenchy dress and a pair of Manhattan sunglasses. Capote initially wanted Marilyn Monroe to play the starring role, but today it is difficult to imagine anyone other than Hepburn in the part.

This poster features artwork by renowned Italian artist Ercole Brini. The last example of it being offered in auction was over a decade ago, and it is easy to see why it's so desirable among collectors. Brini's full-length portrait of Hepburn as Holly Golightly is as chic as the woman herself, and his printed signature can be found in the top left corner.

The poster is conservation linen-backed, with restoration to the top-right border which encroaches slightly on the middle three letters of "Hepburn". There is a 4 cm tear on the top right border, slight fold-line wear, and some tiny areas of surface paper loss in places, all of which has been addressed to a high standard during the backing and restoration process, making the poster display to truly stunning effect. Dimensions (paper only): 140 cm x 198 cm (55" x 78")

**Estimate: £8,000 - 16,000**



**55**  
Mark Darcy's (Colin Firth) Christmas Reindeer Jumper m  
**Bridget Jones's Diary (2001)**

Mark Darcy's (Colin Firth) Christmas reindeer jumper from Sharon Maguire's romantic comedy *Bridget Jones's Diary*. Darcy sported a reindeer jumper at the beginning of the film when he was reintroduced to Bridget Jones (Renee Zellweger) at her parents' annual New Year's Day turkey curry buffet party. Later in the movie, she sarcastically said she was disappointed "not to see my favourite reindeer jumper again" when she met him at a book launch. This jumper was originally donated by Universal Pictures to an auction in 2001.

The dark green knitted turtleneck jumper features a large image of a red-nosed reindeer on the front. There are no size labels present.

Additional Provenance:

Lot 43, Christie's Focusing On Talent: Film And Television Memorabilia Auction, 11th December 2001

**Estimate: £4,000 - 8,000**

**56**  
US One-Sheet Poster m  
**Casablanca (1942)**

A US One-Sheet poster from the promotion of Michael Curtiz's romantic war drama *Casablanca*. The pinnacle of Golden Age Hollywood and perhaps the greatest romantic drama to ever grace the silver screen, *Casablanca* is a classic that has stood the test of time. Starring Humphrey Bogart and Ingrid Bergman, with brilliant support from Claude Rains, Paul Henreid, Peter Lorre and Sydney Greenstreet, this war-time tale centres around cafe owner Rick Blaine (Bogart) who is quietly sitting out the war in French Morocco until his old flame Ilsa (Bergman) re-enters his life with her fugitive husband Victor Laszlo (Henreid). Nominated for eight Academy Awards and winning three, *Casablanca* has an enduring popularity, with any posters from its initial release being prized by collectors worldwide.

Designer Bill Gold said of this poster artwork: "My initial thoughts were to put together a montage showing all the characters depicted in the film. I wanted to have Humphrey Bogart in the foreground and Ingrid Bergman behind him looking on. I didn't want to give away their romance. The client loved it but said there was no excitement, so I put a gun in Bogart's hand."

This example is conservation linen-backed with fold-line restoration and a single drawing-pin hole in three corners, with the top-left hole being slightly bigger than the others. There are four staple holes along each side and a tiny amount of paper loss on the cross-folds. There are also a few areas of very light staining that were not addressed during restoration, and the linen has been cut to the edge but is not fraying. The poster has been stretched lengthways by 1 cm, which is not uncommon during the linen-backing process. Many of these issues are not very noticeable and the poster displays brilliantly. Dimensions: 69 cm x 105 cm (27" x 41.25")

**Estimate: £15,000 - 30,000**



**57**  
Hero Chocolate Bars and Golden Ticket m  
**Charlie And The Chocolate Factory (2005)**

A set of real hero chocolate bars and a golden ticket from Tim Burton's family fantasy film *Charlie and the Chocolate Factory*. Chocolate bars featured heavily in early scenes, as children worldwide vied to win a coveted golden ticket.

This set comprises a Triple Dazzle Caramel in an orange wrapper; a Nutty Crunch Surprise in a red wrapper; a Chilly Chocolate Creme in a blue wrapper; and a Whipple-Scrumptious Fudgemallow Delight in a brown wrapper. Each hero bar is made of real chocolate wrapped in silver foil. There is also an additional lightweight Triple Dazzle Caramel bar made of plastic. The gold-colour foil paper ticket displays an embossed stamp and black text. Dimensions (each bar): 9.5 cm x 19 cm x 1.5 cm (3.75" x 7.5" x 0.5")

Please note this lot is sold as a prop, and is not deemed fit for consumption.

**Estimate: £4,000 - 8,000**





**58**  
**Wonka Box, Wonka Bars, Crew Invites and Crew Gift m**  
**Charlie And The Chocolate Factory (2005)**

A Wonka packaging box, box of 16 Wonka bars, wrap party invite, screening invites, and crew gift chain from the production of Tim Burton's family comedy Charlie and the Chocolate Factory.

Wonka packaging boxes and bars were seen on Mr Salt's (James Fox) factory floors as his workers opened thousands of chocolate bars in search of a golden ticket for his daughter, Veruca (Julia Winter). Wonka bars were also seen throughout the opening act as the rest of the world frantically endeavoured to find the golden tickets.

A printed handwritten note accompanies the wrap party invite, adding further gratitude for the receiver. The crew gift is a metal chain featuring Wonka logos and an engraved coin along its links.

Both the Wonka packaging box and the box containing the Wonka bars exhibit wear in the form of crumpled corners and tears to the surface. Dimensions: (Wonka packaging box) 40.75 cm x 29 cm x 19 cm (16" x 11.5" x 7.5")

**Estimate: £4,000 - 8,000**

**59**  
**Chitty Chitty Bang Bang Spare Wheel m**  
**Chitty Chitty Bang Bang (1968)**

A Chitty Chitty Bang Bang spare wheel from Ken Hughes' musical fantasy Chitty Chitty Bang Bang. Caractacus Potts' (Dick Van Dyke) flying car Chitty Chitty Bang Bang, had a spare wheel fixed to the right-hand side of the car.

The wheel is made of fibreglass and cast from a Goodyear tyre and one of the practical wheels used on the car. It has undergone some recent sympathetic restoration, with the rim of the wheel being repainted.

The tyre has various chips and cracks in the fibreglass due to age and wear. Dimensions: 92 cm x 92 cm x 9.5 cm (36.25" x 36.25" x 3.75")

**Estimate: £4,000 - 8,000**

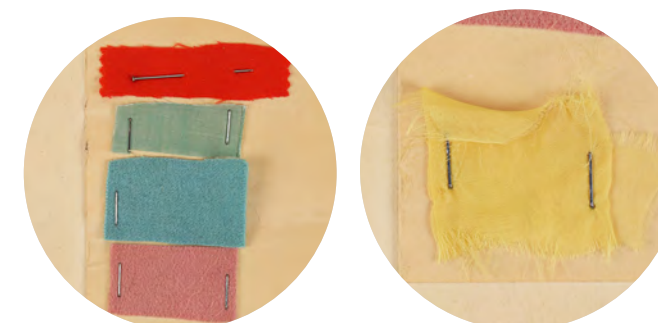

Costume fabric swatches attached to the reverse

**60**  
**Hand-drawn Child Catcher Costume Design and Costume Swatches m**  
**Chitty Chitty Bang Bang (1968)**

A Child Catcher (Robert Helpmann) costume design from the production of Ken Hughes' musical fantasy film Chitty Chitty Bang Bang.

The design is of the Child Catcher's Lollipop Man disguise, and is hand-drawn and coloured by costume designer Joan Bridge, with annotations around the drawing and costume fabric swatches attached to the reverse. A message on the design reads, "For David - With care from Liz and Joan", and a second message, handwritten on the mounting by Helpmann, reads, "To David, With thoughts of your health always. With all my kindest thoughts, Robert H.". Dimensions: 50.5 cm x 40 cm x 0.5 cm (20" x 15.75" x 0.25")

**Estimate: £3,000 - 6,000**



**61**  
**Pair of Roman Shields +Δ**  
**Cleopatra (1963)**

A pair of oval Roman shields from Joseph L. Mankiewicz's historical drama Cleopatra. Oval shields were carried by soldiers in Octavian's (Roddy McDowall) army as it advanced towards Alexandria. At the time of release, Cleopatra was the most expensive film ever made. It was nominated for nine Academy Awards and won four, including Best Costume Design.

Made of fibreglass, each shield features the Roman battle insignia of four eagle wings and six lighting bolts all arranged in a spoke pattern. Both shields are hand-painted in red and a brass tone which has dulled over the years, now resembling dark brown. The back of each shield has two canvas arm straps.

The shields have been intentionally distressed to appear battle-worn, but they also exhibit wear from production use, likely from swords clashing against them. Dimensions (one shield): 75 cm x 55 cm x 7 cm (29.5" x 21.75" x 2.75")

**Estimate: £2,000 - 4,000**

# THE COSTUMI D'ARTE COLLECTION

Costumi d'Arte was established in 1815 when a Napoleonic soldier, Angelo Pignotti opened a small antique shop in Florence, Italy.

Within his eclectic inventory were dresses spanning a period of more than two hundred years. The collection showcased the radical change in the way women dressed. It was a unique, self-contained, historical record of a lost age. After repeated requests from local painters to use the garments for their models, a rental business was born.

In the middle of the century, Egisto Peruzzi, the son-in-law of Pignotti, inherited the business and changed the name to CASA D'ARTE - Firenze - not just to continue to rent authentic clothing but to start making new ones under direct instruction from artists, theatre actors, opera singers and attendees of masked balls and dances.

The company grew again, when Ruggero Peruzzi, Egisto's son and himself an actor, offered the rental service to productions throughout Italy. The geographical

location of the business meant that, with the rise in popularity of cinema, by 1920 the company had expanded to become the famous business recognized globally today. Production of movie costumes has been at the company's heart ever since, growing into a legendary inventory of garments.

In 1947, Giuseppe Peruzzi opened a facility in Rome that housed warehouses and workshops. His son, Ruggero, later took over and changed the name to COSTUMI D'ARTE. He expanded operations to include the theatre tailoring of S.A.F.A.S. led by Mrs. Giuditta Maggioni Roux, acclaimed director Luchino Visconti's entrusted partner on all his projects.

Giuseppe Peruzzi in 1995, and then his son, Jacopo Peruzzi in 2020, have continued the legacy of their predecessors. Peruzzi is a family business for more than a century. It is built on tradition and experience, and its indelible impact on the look of cinema is there for all the world to see. Some of the most iconic images in film history are thanks to COSTUMI D'ARTE.



Cinematic / Alamy Stock Photo



## 62 The Costumi d'Arte Collection: Mark Antony's (Richard Burton) Battle of Actium Costume from Joseph L. Mankiewicz's historical epic Cleopatra. Antony wore his silver-coloured armour as he led the Egyptian navy against Octavian's (Roddy McDowall) Roman fleet in the Battle of Actium. This lot comes from the archives of the Italian costume company Costumi d'Arte.

Mark Antony's (Richard Burton) Battle of Actium costume from Joseph L. Mankiewicz's historical epic Cleopatra. Antony wore his silver-coloured armour as he led the Egyptian navy against Octavian's (Roddy McDowall) Roman fleet in the Battle of Actium. This lot comes from the archives of the Italian costume company Costumi d'Arte.

Seven-time Academy Award nominee Burton was regarded as one of the finest actors of his generation and performed in several films, including Cleopatra, alongside his wife, the iconic actress Elizabeth Taylor. At the time of its release, Cleopatra was the most expensive film ever made. It was nominated for nine Academy Awards and won four, including Best Costume Design.

This costume comprises a helmet, a cuirass, an under-armor tunic and an undergarment tunic. The helmet, cuirass and under-armor tunic are all made predominantly of silver-coloured leather, with metal Roman symbols and detailing.

The helmet has a functioning visor made of metal, and its crest is a set of faux feathers extending from a metal crest holder. Its wooden interior is lined with brown leather to cushion the wearer's head.

The cuirass consists of two sturdy leather torso segments connected at the sides by leather straps, with scalloped parts that loop over the shoulders. The under-armor tunic has "29PE" handwritten in blue ink on its interior beside a printed "Richard Burton" costume label. The tunic is scalloped at the waist and armholes, and fastened by leather straps.

The undergarment tunic, also silver-coloured, is made of crepe. It features olive-leaf patterned sections made from light- and dark-gold-coloured cord, and has a zip at the rear left side. A printed label inside the tunic reads "2399."

**Estimate: £25,000 - 50,000**



Scan here to see a full rotation of this lot



Scan here to see a full rotation of this lot

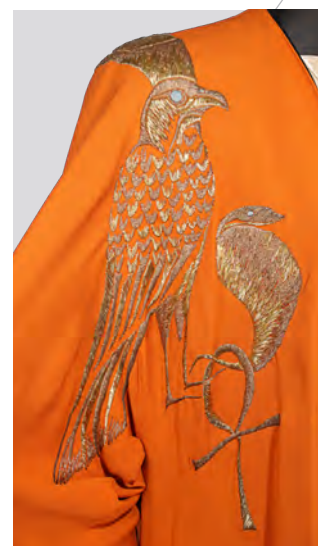

**63**  
The Costumi d'Arte Collection: Cleopatra's (Elizabeth Taylor) Mark Antony (Richard Burton) Death Scene Costume Ω  
**Cleopatra (1963)**

Cleopatra's (Elizabeth Taylor) dress from Joseph L. Mankiewicz's historical epic Cleopatra. The Egyptian queen wore her dress near the end of the film, when she said goodbye to her son, and then in the scene where she held a dying Mark Antony (Richard Burton) in her arms. This lot comes from the archives of the Italian costume company Costumi d'Arte.

At the time of its release, Cleopatra was the most expensive film ever made. It was nominated for nine Academy Awards and won four, including Best Costume Design. Taylor also set a Guinness World Record for the most costume changes in a film, with 65.

The costume comprises a long-sleeved ivory crepe dress and an orange robe decorated with an embroidered gold-and-silver ibis-and-falcon design. The dress has an interior label in the waist on which "Elisabeth [sic] Taylor" is handwritten in blue ink, and features a zip and hook-and-eye fastenings up the back. Both pieces feature interior labels from Costumi d'Arte Peruzzi. The dress has some light staining and discolouration, most notably on the right sleeve, and there is some plucking to areas of the embroidery.

**Estimate: £10,000 - 20,000**



Scan here to see a full rotation of this lot



**64**  
The Costumi d'Arte Collection: Cleopatra's (Elizabeth Taylor) Red Dress and Robe Ω  
**Cleopatra (1963)**

Cleopatra's (Elizabeth Taylor) red dress and robe from Joseph L. Mankiewicz's historical epic Cleopatra. The Egyptian queen wore her dress when she argued with Mark Antony (Richard Burton) over his arranged marriage to Octavia (Jean Marsh). This lot comes from the archives of the Italian costume company Costumi d'Arte.

At the time of its release, Cleopatra was the most expensive film ever made. It was nominated for nine Academy Awards and won four, including Best Costume Design. Taylor also set a Guinness World Record for the most costume changes in a film, with 65.

The red-pink jersey silk dress has a V-neck and no sleeves, with veining on the bodice and a pleated waist. It has a zip, poppers and hook-and-eye fastenings up the back. The robe is made from lilac organza with gold-coloured silk embroidery and golden sequins. In both garments there are interior labels from Costumi d'Arte Peruzzi.

**Estimate: £10,000 - 20,000**



**65**  
The Costumi d'Arte Collection: Mark Antony's (Richard Burton) Defence of Egypt Cuirass and Wrist Guards Ω  
**Cleopatra (1963)**

Mark Antony's (Richard Burton) defence of Egypt cuirass and a pair of wrist guards from Joseph L. Mankiewicz's historical epic Cleopatra. Antony commanded the forces defending Egypt from Octavian's (Roddy McDowall) advancing Roman army, only to be forced to flee back to Alexandria. This lot comes from the archives of the Italian costume company Costumi d'Arte.

Seven-time Academy Award nominee Burton was regarded as one of the finest actors of his generation and performed in several films, including Cleopatra, alongside his wife, the iconic actress Elizabeth Taylor. At the time of its release, Cleopatra was the most expensive film ever made. It was nominated for nine Academy Awards and won four, including Best Costume Design.

The cuirass is made of black leather with red trim and ornate metal symbols and details, including a central depiction of the mythical she-wolf suckling Romulus and Remus, the founders of Rome. The cuirass is scalloped at the shoulders and waist, while two straps loop over the shoulders from the rear piece to connect it to the front piece. "Antonio - R. Burton" is handwritten in black marker pen on a label on the cuirass' interior.

Each wrist guard comprises a metal plate embossed with olive-branch designs and a leather underside, with laces to secure it to the wearer.

**Estimate: £10,000 - 20,000**



**66**  
The Costumi d'Arte Collection: Cleopatra's (Elizabeth Taylor) Vision Dress Ω  
**Cleopatra (1963)**

Cleopatra's (Elizabeth Taylor) dress from Joseph L. Mankiewicz's historical epic Cleopatra. The Egyptian queen wore her dress as she said goodbye to Julius Caesar (Rex Harrison), before witnessing a vision of his murder at the hands of Brutus (Kenneth Haigh) and his fellow senators. This lot comes from the archives of the Italian costume company Costumi d'Arte.

At the time of its release, Cleopatra was the most expensive film ever made. It was nominated for nine Academy Awards and won four, including Best Costume Design. Taylor also set a Guinness World Record for the most costume changes in a film, with 65.

The costume comprises a purple jersey silk dress with a pleated bodice and waist, and a red crepe stole with an embroidered golden silk snake. The dress has an interior label in the neckline on which "Liz Taylor Cleopatra" is handwritten, and a label from Costumi d'Arte Peruzzi. The garment has some light staining and discolouration, most notably around the chest, arms and hem.

**Estimate: £8,000 - 16,000**



Allstar Picture Library Limited / Alamy Stock Photo



Masheter Movie Archive / Alamy Stock Photo



**67**  
The Costumi d'Arte Collection: Cleopatra's (Elizabeth Taylor) Introductory Dress  $\Omega$  **Cleopatra (1963)**

Cleopatra's (Elizabeth Taylor) introductory dress from Joseph L. Mankiewicz's historical epic Cleopatra. The Egyptian queen wore her dress when she first met Julius Caesar (Rex Harrison), having been snuck into his room in a rolled-up carpet. She was then rolled onto the floor in an iconic entrance. This lot comes from the archives of the Italian costume company Costumi d'Arte.

At the time of its release, Cleopatra was the most expensive film ever made. It was nominated for nine Academy Awards and won four, including Best Costume Design. Taylor also set a Guinness World Record for the most costume changes in a film, with 65.

The dress is made of orange suede and features a V-neck and waist-high splits down each side. It is worn over a white pleated underskirt and is accompanied by a small orange belt. The dress has some light discolouration and minor staining, most notably around the armpits.

**Estimate: £6,000 - 12,000**

**68**  
The Costumi d'Arte Collection: Mark Antony's (Richard Burton) Pre-Battle of Actium Cuirass  $\Omega$  **Cleopatra (1963)**

Mark Antony's (Richard Burton) pre-Battle of Actium cuirass from Joseph L. Mankiewicz's historical epic Cleopatra. Antony argued with his officers as they questioned his obstinate wish to fight Octavian (Roddy McDowall) at sea rather than on land. This lot comes from the archives of the Italian costume company Costumi d'Arte.

Seven-time Academy Award nominee Burton was regarded as one of the finest actors of his generation and performed in several films, including Cleopatra, alongside his wife, the iconic actress Elizabeth Taylor. At the time of its release, Cleopatra was the most expensive film ever made. It was nominated for nine Academy Awards and won four, including Best Costume Design.

The cuirass is made of leather, coloured burgundy and brown, with ornate metal symbols and detailing. "R. Burton" is handwritten in black ink on a label stuck to the inside of the cuirass.

**Estimate: £6,000 - 12,000**

**69**  
The Costumi d'Arte Collection: Mark Antony's (Richard Burton) Death Costume  $\Omega$  **Cleopatra (1963)**

Mark Antony's (Richard Burton) death costume from Joseph L. Mankiewicz's historical epic Cleopatra.

Mark Antony wore his costume during his death scene, when, having been defeated in battle, he plunged a sword into his own stomach. This lot comes from the archives of the Italian costume company Costumi d'Arte.

Seven-time Academy Award nominee Burton was regarded as one of the finest actors of his generation and performed in several films, including Cleopatra, alongside his wife, the iconic actress Elizabeth Taylor. At the time of its release, Cleopatra was the most expensive film ever made. It was nominated for nine Academy Awards and won four, including Best Costume Design.

The costume consists of black leather under armour with fringes along the waist, dark red leather trims, and five black leather chest straps with burnished metal studs; and a short dark grey crepe tunic which features metal zips on the left shoulder and left side. Both the under armour and tunic feature costume labels from Costumi d'Arte Peruzzi, and the tunic also features a label with "Burton" handwritten in black ink. The under armour has "29 PE" handwritten in the neckline.

**Estimate: £6,000 - 12,000**

**70**  
The Costumi d'Arte Collection: Mark Antony's (Richard Burton) Senate Costume  $\Omega$  **Cleopatra (1963)**

Mark Antony's (Richard Burton) Senate costume from Joseph L. Mankiewicz's historical epic Cleopatra. Antony wore his toga while attending a senate session as news of the birth of Cleopatra (Elizabeth Taylor) and Julius Caesar's (Rex Harrison) son spread through Rome. This lot comes from the archives of the Italian costume company Costumi d'Arte. Seven-time Academy Award nominee Burton was regarded as one of the finest actors of his generation and performed in several films, including Cleopatra, alongside his wife, the iconic actress Elizabeth Taylor. At the time of its release, Cleopatra was the most expensive film ever made. It was nominated for nine Academy Awards and won four, including Best Costume Design.

The costume features an ivory-coloured sleeveless linen tunic with a red cotton front, featuring laurel crown-and-leaf embroidery in dark and light gold-coloured cord, and a zip on the rear left side. The costume also includes an ivory-coloured linen mantle with a red cotton border and leaf embroidery in dark and light gold-coloured cord. Each shoulder of the mantle has a metal pin painted to look like gold but these are not original to the film. The tunic exhibits a small hole towards the waist in the red cotton section.

**Estimate: £5,000 - 10,000**



**71**  
The Costumi d'Arte Collection: Mark Antony's (Richard Burton) Crowning Costume  $\Omega$   
**Cleopatra (1963)**

Mark Antony's (Richard Burton) crowning costume from Joseph L. Mankiewicz's historical epic Cleopatra. After leading the Roman alliance against the rebellion and avenging Caesar (Rex Harrison), Antony was crowned with a laurel wreath before his legions. This lot comes from the archives of the Italian costume company Costumi d'Arte.

Seven-time Academy Award nominee Burton was regarded as one of the finest actors of his generation, and performed in several films, including Cleopatra, alongside his wife, the iconic actress Elizabeth Taylor. At the time of its release, Cleopatra was the most expensive film ever made. It was nominated for nine Academy Awards and won four, including Best Costume Design.

The costume comprises a cuirass, a set of straps and a tunic. The cuirass is made of brown leather featuring ornate metal symbols, including eagles. It is scalloped and tasselled at the shoulders. The straps are also made of brown leather with metal embellishments depicting eagles and lion heads. "29PE" is handwritten in black ink on the underside of the straps, which are secured and fastened by metal buckles at the sides. The tunic is made of crepe and features olive-leaf pattern sections made from light and dark-gold-coloured cord. It has a zip on the left side, and an interior label has "2548" sewn in red thread.

**Estimate: £5,000 - 10,000**



**72**  
The Costumi d'Arte Collection: Julius Caesar's (Rex Harrison) Screen-matched Cuirass  $\Omega$   
**Cleopatra (1963)**

Julius Caesar's (Rex Harrison) screen-matched cuirass from Joseph L. Mankiewicz's historical epic Cleopatra. Caesar wore his cuirass at the beginning of the film as he spoke to his soldiers after the Battle of Pharsalus, and also when he first travelled to Egypt. The cuirass screen matches these scenes through several distinctive marks and creases on the front plate. This lot comes from the archives of the Italian costume company Costumi d'Arte.

At the time of its release, Cleopatra was the most expensive film ever made. It was nominated for nine Academy Awards - including Harrison for Best Actor - and won four, including Best Costume Design.

The cuirass comprises front and back plates, both made of thick brown leather. The front plate is decorated with metal embellishments, including flowers, griffons and an eagle, and the two plates are attached via leather straps and metal buckles down each side. There is an interior label from Costumi d'Arte Peruzzi

**Estimate: £5,000 - 10,000**

**73**  
Alien Creature Costume  $\mu$   
**Close Encounters Of The Third Kind (1977)**

An alien creature costume from Steven Spielberg's sci-fi drama Close Encounters of the Third Kind. Diminutive extraterrestrial creatures revealed themselves to humanity during the film's climax at Devil's Tower. These costumes were made so small that the aliens had to be played by six-year-old girls.

The costume comprises a slip-on latex mask and a one-piece spandex bodysuit. The mask features an open nose and mouth to assist the child performer's breathing and is painted in shades of grey and green to enhance the alien appearance. The eyes have blue irises and are glossed over for effect, with holes in the pupils to accommodate vision. The unitard is made from spandex, with rubber grips attached to the soles of the feet.

The costume is mounted on a custom-made display featuring the film's title, which illuminates when powered. Dimensions: 30 cm x 40 cm x 100 cm (12" x 15.75" x 39.5")

Contains electronics; see electronics notice in the Buyer's Guide.

Special shipping required; see special shipping notice in the Buyer's Guide.

**Estimate: £20,000 - 40,000**

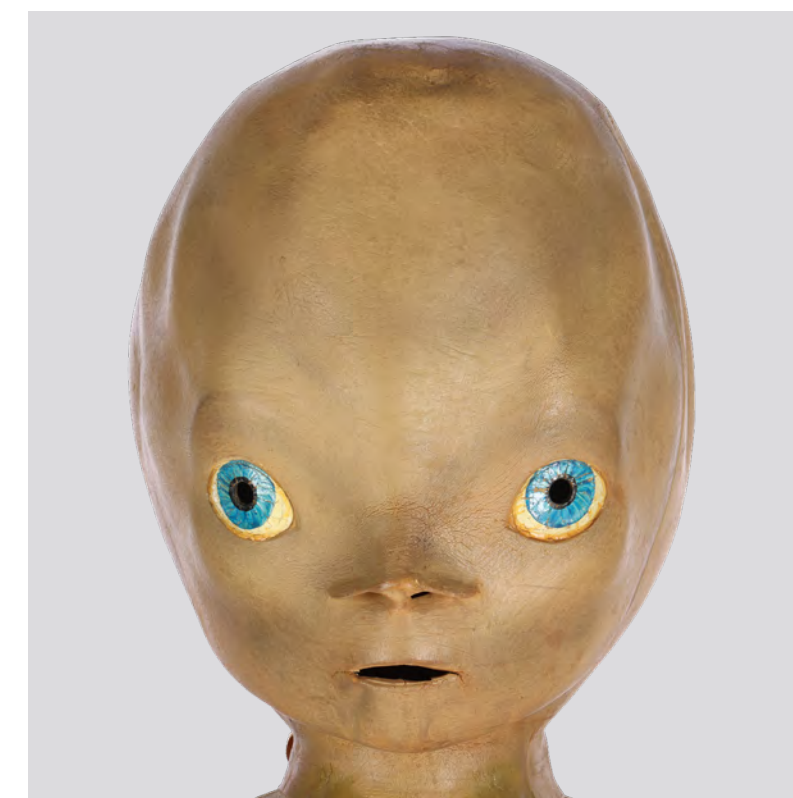



**74**  
 Screen-matched Hero "Chucky"  
 Good Guy Doll †Δ  
**Cult Of Chucky (2017)**

A screen-matched hero "Chucky" Good Guy doll from Don Mancini's horror sequel Cult of Chucky. Chucky (voiced by Brad Dourif) possessed the body of a Good Guy doll to go on a murderous rampage through a psychiatric hospital and expand his cult. This doll's print pattern and facial imperfections screen-match it to several scenes during the early part of the film.

Created by effects studio Alterian Inc., this doll features a vinyl head and hands; hand-painted eyelashes and freckles; a glued-on red synthetic wig; blue urethane eyes; and a Polyfilla-filled cloth body. It is dressed in custom-made clothing, including a colourfully striped long-sleeved knit top; a pair of dungarees featuring a toy print pattern; a pair of red socks; and a pair of red-and-white vinyl shoes. Both the front pocket on the dungarees and the shoelaces display the doll's brand name, "Good Guys". This doll exhibits some matting of the synthetic hair and imperfections from the production process. Dimensions: 77 cm x 33 cm x 20 cm (30" x 13" x 8")

**Estimate: £15,000 - 30,000**

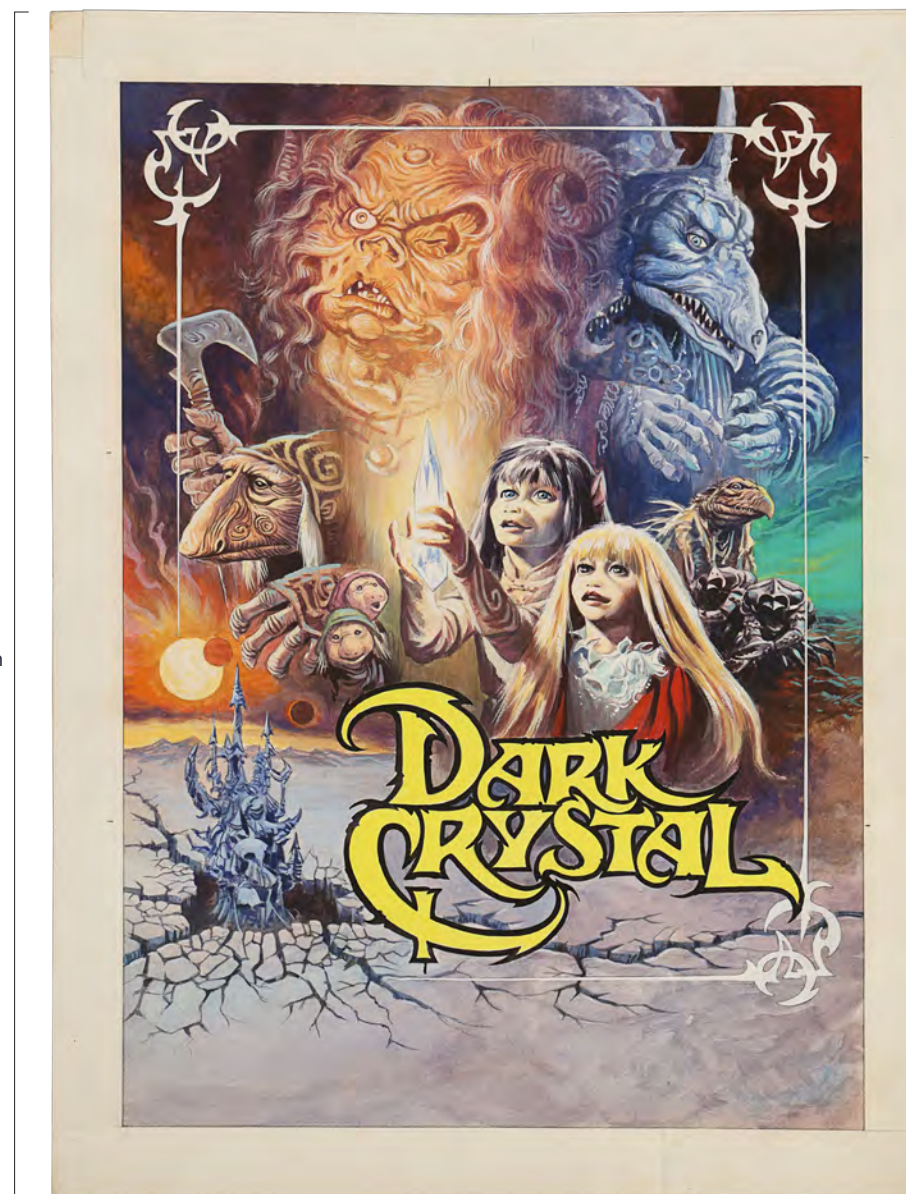

33.75 cm  
 (13.25")

**75**  
 Hand-painted Original Preliminary  
 Poster Artwork †Δ ARR  
**The Dark Crystal (1982)**

A piece of hand-painted original preliminary poster artwork from the promotion of Frank Oz and Jim Henson's fantasy film The Dark Crystal. Featuring a unique world entirely of Henson and Oz's creation, this cult classic concerns the quest of a Gelfling boy named Jen to repair the titular Dark Crystal and restore balance to his planet, Thra.

Italian artist Bruno Napoli was commissioned to design the film's European poster, with this piece being one of the final concepts considered by the production before they settled on the final version. Hand-painted by Napoli, it differs only slightly from the final design. The same characters are present, and their poses and positioning are almost exactly the same, although the colour tones were altered for the final version. Dimensions: 33.75 cm x 25.5 cm (13.25" x 10")

Sold without copyright; see copyright notice in the Buyer's Guide.

**Estimate: £10,000 - 20,000**

**76**  
 Hand-painted Main Title Artwork †Δ ARR  
**The Dark Crystal (1982)**

A piece of main-title artwork from the production of Frank Oz and Jim Henson's fantasy film The Dark Crystal. This fantasy cult classic follows the quest of a Gelfling named Jen to find a missing shard of the Dark Crystal and restore order to his world.

This piece of airbrushed artwork by Italian artist Bruno Napoli was used for the film's European commercial posters. It is adhered to a square piece of cardboard. Dimensions: 39 cm x 25.25 cm (15.25" x 10")

Sold without copyright; see copyright notice in the Buyer's Guide.

**Estimate: £3,000 - 6,000**

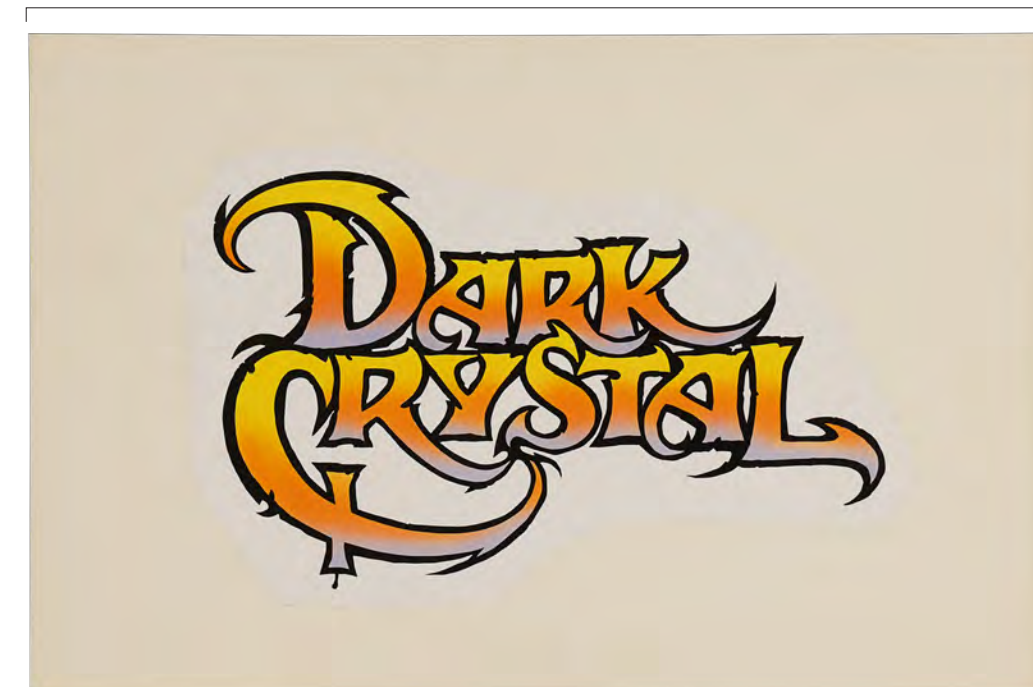

39 cm (15.25")

**77**  
**Space Mountain Ride Vehicle US**  
**Disneyland Park**

A Space Mountain ride vehicle from Disneyland Park. First opened in 1977, Space Mountain is a steel-frame enclosed roller coaster with a "wild mouse" layout that relied on sharp flat turns, small hills and rapid hops as compared to other roller coasters with drops and dives.

Space Mountain was Disneyland's second roller coaster after the Matterhorn Bobsleds, and the second version built with its exterior serving as one of Disneyland's iconic mountain-like landmarks. During opening, six of the original Mercury astronauts attended the ceremony and a new attendance record was set for Disneyland over the course of the Memorial Day weekend. One of the popular dark ride attractions with an immersive experience including sound effects and music, Space Mountain underwent a series of cosmetic renovations starting in 1997. During one of the ride refurbishments, speakers were added to the cars.

This lot consists of a three-row, two-seater vehicle shaped like a rocket painted grey with white glow-in-the-dark panels and blue bucket seats. It is numbered "6" and features a red rubber front bumper, denoting it as the front car of a train, which is why the rear jets are absent. The vehicle is made of metal and fiberglass with foam and rubber components. It has a lap bar for each seat and a safety plaque for each row. The vehicle exhibits a buildup of grime in the crevices, discolouration, a crack in the hull, and cracked and fragile rubber and foam. This lot is accompanied by a pair of 35mm slides. Dimensions: 365.75 cm x 117 cm x 96.5 cm (144" x 46" x 38")

Special shipping required; see notice in the Buyer's Guide.

Contains electronic and mechanical components; see notice in the Buyer's Guide.

**Estimate: £30,000 - 60,000**



3.65 m (12')





10 cm  
(4")

**78**  
Captain Knight's (Ralph Watson) Yeti Homing Device  
Figurine m  
**Doctor Who Original Series - The Web of Fear (1968)**

Captain Knight's (Ralph Watson) Yeti homing device figurine from the BBC sci-fi television series Doctor Who. The homing device, used to attract robot yetis, featured throughout "The Web of Fear", the fifth serial in the fifth series of the original Doctor Who. The serial comprised six episodes, though all but one were missing from the BBC archive for 40 years.

The yeti is made of resin, painted to resemble wood. The lot also includes a BBC compliment slip and an autographed photo of Ralph Watson, who played Captain Knight alongside Patrick Troughton's Doctor. The photo is autographed in gold ink by Watson, who has also written the name of his character. Dimensions (yeti): 10 cm x 5 cm x 5 cm (4" x 2" x 2")

**Estimate: £10,000 - 20,000**



1.68 m  
(5.1')

**79**  
1970s Exhibition Dalek m  
**Doctor Who Original Series (T.V. Series, 1963 - 1989)**

A 1970s BBC-made Longleat exhibition Dalek, the notorious extraterrestrial race from beloved sci-fi TV series Doctor Who.

One of the visual effects designers on the show, Tony Oxley, and visual effects assistant, Charlie Lumm, built this Dalek for the Longleat Doctor Who exhibition in April of 1974. The Dalek remained on display in Longleat until its closure in 2003, before it was transferred to the Blackpool Doctor Who exhibition, where it was exhibited from 2004 to 2009. In 2013, the Dalek was exhibited for the 50th anniversary BBC Public showing of An Unearthly Child, while appearing on the ITV show This Morning in the same year.

The Dalek is predominantly made of wood, painted to look like metal. This includes its skirt and its "sense globes", as well as its eye stalk. The gun stick is made of metal, as is the mesh section at the Dalek's collar. The suction cup comprises a metal rod and a rubber head.

When connected to its mains lead, the Dalek's suction cup and eye stalk move, while the eye and the two dome lights illuminate. The Dalek's plastic belt exhibits cracking and peeling.

Dimensions: 153 cm x 90 cm x 168 cm (60.25" x 35.5" x 66.25")

Contains electronics; see electronics notice in the Buyer's Guide.

Special shipping required; see special shipping notice in the Buyer's Guide.

**Estimate: £3,000 - 6,000**



49 cm (19.25")

**80**  
Dalek Model Miniature m  
**Doctor Who - The Day of the Doctor (2013), The Time of the Doctor (2013)**

A Dalek miniature from the BBC sci-fi television series Doctor Who. Miniature 1:4 scale Daleks were used for special effects sequences in the 50th anniversary episode 'The Day of the Doctor' and the 2013 Christmas Special 'The Time of the Doctor'. The miniatures were built and filmed by effects house The Model Unit, who received the BAFTA Television Craft Award for Best Special, Visual and Graphic Effects for their work on The Day of the Doctor.

The Dalek separates at the midsection, and is wired through the top section to light up. It is operated by a servo control. The electronics are functional, and aside from some paint wear, the Dalek remains in very good condition. Dimensions: 27 cm x 29 cm x 49 cm (10.75" x 11.5" 19.25")

Contains electronics; see electronics notice in the Buyer's Guide.

**Estimate: £7,000 - 14,000**







76 cm (30")



**81**  
**BBC-made Exhibition TARDIS Model Miniature from Blackpool and Llangollen Exhibitions m Doctor Who (T.V. Series, 2005-Present)**

A BBC-made exhibition TARDIS miniature from the BBC sci-fi television series Doctor Who.

Created for exhibition purposes and exhibited at the Doctor Who Exhibition in Blackpool and the Dapol Doctor Who Experience in Llangollen - the largest Doctor Who Exhibition ever staged - this miniature TARDIS is made of blue-painted wooden boards, and features plastic windows backed with orange-coloured paper to simulate the appearance of orange light within. Adhered to each side is a sticker that reads "Police Public Call Box", and affixed to the doors is a sign, though this has been populated with filler text rather than the original text that featured in the show. The doors do not open. The TARDIS exhibits some paint wear and cracking in the wood, but otherwise remains in good condition. Dimensions: 38.5 cm x 38.5 cm x 76 cm (15.25" x 15.25" x 30")

**Estimate: £6,000 - 12,000**



Everett Collection Inc. / Alamy Stock Photo

**82**  
**The Costumi d'Arte Collection: Gabriel Feraud's (Harvey Keitel) Costume o The Duellists (1977)**

Gabriel Feraud's (Harvey Keitel) costume from Ridley Scott's historical drama The Duellists. Feraud wore his costume throughout the film, often donning his officer's uniform for his many meetings with his rival Armand d'Hubert (Keith Carradine). The film was widely praised for the accuracy of its Napoleonic-era uniforms. This lot comes from the archives of the Italian costume company Costumi d'Arte.

The costume comprises a faux-fur-trimmed green outer jacket; a green inner jacket; a pair of red trousers; a decorative red belt; and a shako hat. Both jackets and the trousers have "Keitel" handwritten on labels, and the outer jacket and trousers are both labelled size "48". The outer jacket features tassel details and golden-corded detailing down the front. The shako is lined with foam and features a metal insignia on the front engraved with the number "7" and an image of an eagle. It also has metal chin scales, a blue, red and white cockade, and decorative rope details. Inside the hat are two stickers on which "56" and "box 8 arte" are handwritten. Some of the jacket's fur is thinning in places.

**Estimate: £15,000 - 30,000**





**83**  
 The Costumi d'Arte Collection: Armand d'Hubert's  
 (Keith Carradine) Costume Ω  
**The Duellists (1977)**

Armand d'Hubert's (Keith Carradine) costume from Ridley Scott's historical drama *The Duellists*. D'Hubert wore his costume throughout the film, often donning his officer's uniform for his many meetings with his rival Gabriel Feraud (Harvey Keitel). The film was widely praised for the accuracy of its Napoleonic-era uniforms. This lot comes from the archives of the Italian costume company Costumi d'Arte.

The costume comprises a faux-fur-trimmed grey outer jacket; a grey inner jacket; a pair of grey trousers; a decorative red belt; and a shako hat. Both jackets and the trousers have "Carradine" handwritten on labels, and the inner jacket and trousers are both labelled size "46". The outer jacket features tassel details and silver-corded detailing down the front. The shako is lined with foam and features a metal insignia on the front engraved with the number "3" and an image of an eagle. It also has metal chin scales, a blue, red and white cockade, and decorative rope details. There is a small hole in the top of the shako.

**Estimate: £10,000 - 20,000**

**84**  
 Rita Vrataski's (Emily Blunt) Helicopter Blade Sword m  
**Edge Of Tomorrow (2014)**

Rita Vrataski's (Emily Blunt) helicopter blade sword from Doug Liman's sci-fi action film *Edge of Tomorrow*. Vrataski, the "Angel of Verdun," carried her blade on the battlefield during Major William Cage's (Tom Cruise) first day of combat and became the poster girl for the war, frequently pictured with her unique weapon of choice.

The weapon is made of black-painted polyurethane shaped to resemble a helicopter tail-rotor blade, with foil fixed along the blade's narrow edge to represent sharpened metal. A distressed sticker near the hilt bears the logo for the alien-battling United Defence Force (UDF) and includes information on the fictional vehicle from which it originated, and a range of alphanumeric digits are spray-painted further along the blade in pale brown. The pommel is painted metallic grey and the blade includes a line of red spray paint across the tip. The lot exhibits intentional production distressing. Dimensions: 122 cm x 16 cm x 5.75 cm (48" x 6.25" x 2.25")

Edged, bladed or blunt object; see notice on Blades in the Buyer's Guide.

**Estimate: £12,000 - 24,000**





**85**  
**Exosuit Shoulder Cannon M**  
**Edge Of Tomorrow (2014)**

An ExoSuit shoulder cannon from Doug Liman's sci-fi action film Edge of Tomorrow. United Defence Force (UDF) soldiers, including Rita Vrataski (Emily Blunt), fought against the extraterrestrial Mimics in ExoSuits featuring shoulder cannons.

Designed as a railgun-like heavy weapon, the piece was mounted on the suit's back right-hand pylon. The cannon's main body comprises parts made from biscuit foam, rubber and resin. Attached to the main body are a set of foam-rubber tubes and a canister predominantly made of biscuit foam. Many of the weapon's compartments are painted to resemble different metals. UDF stickers and inventory labels are present across the cannon and canister.

The lot is displayed on two short wooden planks, attached by metal screws.

The cannon has been distressed to appear battle-worn. However, it also exhibits peeling to the paintwork and part of the barrel's rubber section has snapped. Dimensions: 69 cm x 50 cm x 40 cm (27.25" x 19.75" x 15.75")

**Estimate: £4,000 - 8,000**



**87**  
**Max Da Costa's (Matt Damon) Screen-matched Light-up Mechanical TST Chemrail Rifle Ω**  
**Elysium (2013)**

Max Da Costa's (Matt Damon) screen-matched, light-up, mechanical TST Chemrail rifle from Neill Blomkamp's Elysium. Paint and engraving details on the exterior of this rifle screen-match to when Max rescued Frey Santiago (Alice Braga) and her daughter Matilda (Emma Tremblay) from M. Kruger (Sharlto Copley) and his minions.

Designed and constructed by Weta Workshop, this futuristic fictional firearm features a dense rubber clamshell engraved "For Asgari Use Only" and "Chemrail TST" and dressed over a metal interior; a depressible trigger; a grey magazine engraved "LMR 8.75x52" (a reference to the size of the Fin Stabilised Discarding Rail Accelerator Sabot [FSDRAS] rounds Chemrails are designed to fire); and a green butt engraved "18kj" (for the muzzle energy, in kilojoules, with which Chemrails fire FSDRAS rounds).

The rifle is equipped with a CO2 gas-powered muzzle operated via a switch concealed on the bottom of the magazine. When the rifle is connected to an AC-powered battery pack, the muzzle pumps at high velocity by depressing the trigger. A light above the muzzle also flashes when a button concealed in front of the forestock is pressed simultaneously with the trigger. A battery pack and its AC-compatible charger are also included with the rifle.

Following production, this lot underwent sympathetic restoration to its electronic components. It is missing its scope as well as panelling along the top of the clamshell, which also exhibits adhesive residue, some grime and discolouration along the muzzle, and bending to the rubber elements from production and handling. Dimensions: 99.25 cm x 33.25 cm x 7.75 cm (39" x 13" x 3")

Ownership may be restricted in some countries; see replica firearm notice in Buyer's Guide.

Contains electronics; see electronics notice in the Buyer's Guide.

**Estimate: £8,000 - 16,000**

**86**  
**Queen Elizabeth's (Cate Blanchett) Red Gown + Elizabeth (1998)**

Queen Elizabeth's (Cate Blanchett) red gown from Shekhar Kapur's biographical period drama Elizabeth. Elizabeth wore her velvet gown while she tried to convince religious leaders to back her Act of Uniformity. The film was nominated for seven Academy Awards, including for Costume Design, and won one. The gown is formed of two parts: a long-sleeved bodice and a long skirt. Both feature interior labels from costumiers Angels with "Elizabeth I - 'Elizabeth' - Cate Blanchett" handwritten on them.

**Estimate: £4,000 - 8,000**



**88**  
**Screen-matched Lipstick Beauty Salon Sign US**  
**Female Trouble (1974)**

A screen-matched Lipstick Beauty Salon sign from John Waters' Female Trouble. Dawn Davenport (Divine) frequented the Lipstick Beauty Salon, whose owners, Donald (David Lochary) and Donna Dasher (Mary Vivian Pearce), seduced Dawn into a life of beautiful crime. Distinctive welds and shaping from metal work on this sign screen-match to shots throughout the film.

Waters' fourth film - a landmark in independent cinema and a continuation of the director's long-standing collaboration with star Divine - was production designed by Vincent Peranio. The movie's unique aesthetic has been repeatedly praised, earning it a spot in the Criterion Collection in 2018.

This purple and green metal sign reading "Lipstick Beauty Salon" in curly cursive lettering was previously exhibited in the Academy Museum of Motion Pictures' "John Waters: Pope of Trash" exhibition. It exhibits signs of age, including some wear throughout the finish. Dimensions: 141 cm x 81.5 cm x 4.5 cm (55.5" x 32" x 1.75")

**Estimate: £8,000 - 16,000**





**89**  
**Animatronic Mondoshawan Head**  
**The Fifth Element (1997)**

A hero animatronic Mondoshawan head from Luc Besson's sci-fi action film The Fifth Element. The giant, well-meaning Mondoshawans were seen at the opening of the film when they arrived on Earth to retrieve the Fifth Element and its four elemental stones.

This head features animatronics and is made of fibreglass, with resin detailing and a grey rubber neck seal. It is finished in a dappled faux-gold paint finish to give the creature an antiquated look, with orange used for the eyes.

The head is attached to a production workshop stand featuring a battery pack and circuit board. When powered with four AA batteries and activated by a button, it moves side to side.  
 Dimensions (displayed): 46 cm x 31 cm x 46 cm (18" x 12.25" x 18")

Contains electronics; see electronics notice in the Buyer's Guide.

Contains mechanical components; see mechanical notice in the Buyer's Guide.

**Estimate: £10,000 - 20,000**

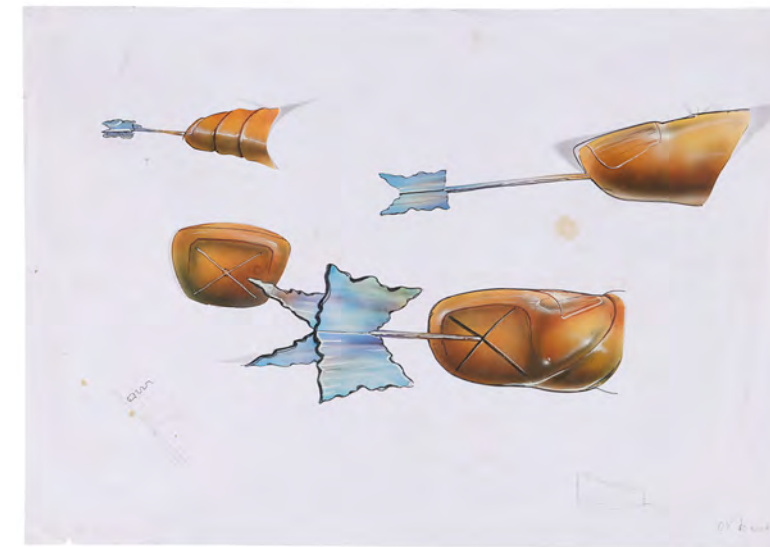

**90**  
**Element Key and Concept Art**  
**The Fifth Element (1997)**

The Element Key from Luc Besson's sci-fi adventure film The Fifth Element. The Element Key was given to Professor Pacoli (John Bluthal) by a Mondoshawan in 1914 and passed down through the generations by a secretive order of priests. When the Great Evil returned to Earth in 2263, the key was carried by Vito Cornelius (Ian Holm), who used it to grant Korben Dallas (Bruce Willis) access to a stone chamber and activate the weapon contained within.

The key comprises four metal blades on the end of a thin metal rod. Each blade features an ornate pattern and the entire key has a bronzed finish, intentionally tarnished to look hundreds of years old. The concept art is hand-coloured and comprises drawings of the key from various angles, each of which is adhered to a sheet of A3 paper. Small, hand-drawn pencil sketches accompany the coloured images, and the design of the key differs from the final prop. The key has some wear from production use and age, including sections at the base of the blades where the soldering is visible, and some of the concept drawings are lifting from the paper where the adhesive has weakened with age. The paper also exhibits some minor staining and tears at the edges, though these do not disrupt the artwork. Otherwise, both items remain in good condition.  
 Dimensions: 33 cm x 7 cm x 5 cm (13" x 2.75" x 2")

**Estimate: £5,000 - 10,000**



33 cm (13")



**91**  
**J.M. Barrie's (Johnny Depp)**  
**Circus Ringmaster Costume + Δ**  
**Finding Neverland (2004)**

J.M. Barrie's (Johnny Depp) circus ringmaster costume from Marc Forster's biopic Finding Neverland. Barrie wore his ringmaster costume when he first met the Davies family. He danced with his dog Nana for the amusement of the family, and in their imagination was dressed as a circus ringleader, dancing with a bear.

The costume was designed by Alexandra Byrne, who received an Academy Award nomination for her work on Finding Neverland, and later won an Oscar for Elizabeth: The Golden Age. It comprises a double-breasted tailcoat made of silk velvet, with printed paisley patterns on the collar and gold lame insertions; a matching waistcoat with russet velvet and gold lame; a pair of ivory satinised cotton trousers with elasticated stirrups; a linen shirt with a shaped collar; a pair of black leather boots with crimson leather lining; and a black plush top hat. Each costume piece features an interior handwritten "Johnny Depp" label.

The costume comes on a custom-made display. It shows some wear from use, including worn areas and slightly split seams, and is accompanied by an autographed photo of Depp. Dimensions (on display) 37.5 cm x 53 cm x 196 cm (14.75" x 20.75" x 77.25")

Special shipping required; see special shipping notice in the Buyer's Guide.

**Estimate: £8,000 - 16,000**



**92**  
**Forrest Gump's (Tom Hanks)**  
**Screen-matched Bubba Gump**  
**Shrimp Co. Cap M**  
**Forrest Gump (1994)**

Forrest Gump's (Tom Hanks) screen-matched Bubba Gump Shrimp Co. cap from Robert Zemeckis' Academy Award-winning historical drama Forrest Gump. Forrest wore a cap that became increasingly weathered as he ran from one coast of the USA to the other and back. Mud stains on its logo match this cap to the one seen on screen while Forrest is interviewed at the outset of his run, and also in a photograph of Forrest in Jenny's (Robin Wright) scrapbook. This crimson cotton-blend, one-size-fits-all adult baseball hat is embossed with a red, white, blue and pink patch featuring the Bubba Gump Shrimp Co. logo. The hat is intentionally distressed and stained by production with grime and dirt to appear extensively worn. Dimensions: 25 cm x 21.5 cm x 12.5 cm (9.75" x 8.5" x 5")

**Estimate: £15,000 - 30,000**



Album / Alamy Stock Photo



Scan here to see a full rotation of this lot



**93**  
**Fraggle Puppet †Δ**  
**Fraggle Rock (T.V. Series, 1983-1987)**

A Fraggles puppet from the classic children's TV series Fraggles Rock. The Fraggles were tiny humanoid creatures that lived on radishes and inhabited the natural caves within the titular peninsula. The series was conceived by the legendary Jim Henson, creator of The Muppets and director of The Dark Crystal and Labyrinth.

This Fraggles is one of a horde of unnamed background characters that followed Gobo, Mokey, Wembley and Red on assorted escapades. He can be seen in various episodes wearing different costumes, but his slightly wonky eyes remain consistent. The general Fraggles population came in a multitude of different sizes and colours. This one is vivid orange and is constructed from soft "Muppet material". His red hair is made from dyed feathers that give a lifelike bounce even with the slightest movement. A tag inside reads "Property of The Muppets" and has "Gaggle 12/82 'Pudgy Gold' Toronto Exhibit" handwritten in red pen.

The puppet was gifted to a senior crew member on completion of the final episode in 1987, and it sits on a custom-made display stand. Dimensions (display): 35 cm x 30 cm x 41 cm (13.75" x 11.75" x 15.75")

**Estimate: £40,000 - 80,000**





**94**  
**Freddy Krueger's (Robert Englund) Fedora Ω**  
**Freddy Vs. Jason (2003)**

A Freddy Krueger (Robert Englund) hat from Ronny Yu's horror crossover Freddy Vs. Jason. The dream-stalking Freddy wore his signature fedora throughout the film, while battling infamous serial killer Jason Vorhees (Ken Kirzinger). This hat originally came from a New Line Cinema Studio auction. Krueger is one of the most iconic villains in horror movie history and his fedora, along with his jumper and bladed glove, are vital aspects of his

Made of brown felt, the fedora (marked as size 6 7/8) is manufactured by Edie's Hats of Vancouver. Adhered to its leather sweatband is a strip of masking tape, on which the text "stmd, sndd, edge scraped" and "cut 7 1/8" are handwritten in black marker and black ballpoint pen, respectively. The hat features intentional distressing, including a number of small nicks and cuts, to imply it has been damaged by Krueger's iconic bladed glove. Dimensions 31.5 cm x 27.5 cm x 14 cm (12.5" x 10.75" x 5.5").

**Estimate: £10,000 - 20,000**

**95**  
**Rachel Green's (Jennifer Aniston) Screen-matched Princess Leia Slave Costume ΩΔ**  
**Friends (T.V. Series, 1996) - The One with the Princess Leia Fantasy (1996)**

Rachel Green's (Jennifer Aniston) screen-matched Princess Leia slave costume from Friends. Green wore a costume reminiscent of the one worn by Princess Leia (Carrie Fisher) during her enslavement to Jabba the Hutt in Star Wars: Return of the Jedi to try to fulfil the fantasy that Ross Geller (David Schwimmer) had earlier admitted to her in the Season 3 episode "The One with the Princess Leia Fantasy." Unique folds sewn into the gold-colour piping along the brassiere and fabric patterning at the "belt" at the bottom screen-match to the episode.

This costume consists of a maroon elastane-blend and silken brassiere top with gold-colour piping along the edges, gold-colour bars in the centre and small faux gems adhered to it; a pair of pink chiffon trousers with open sides, elastic ankle bands, a gold-colour belt element with swirling piping; and a pair of matching briefs.

Following filming, overlapping piping details were removed from the brassiere, while the skirt was modified to allow it to loop around the wearer. As a result, the costume currently differs in appearance from what it looked like at the time of filming. The costume exhibits some staining and the gold-colour finish is flaking off.

**Estimate: £5,000 - 10,000**

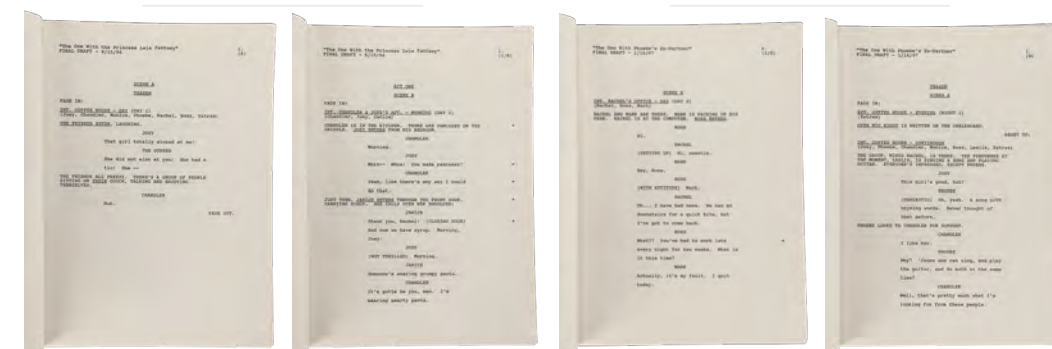
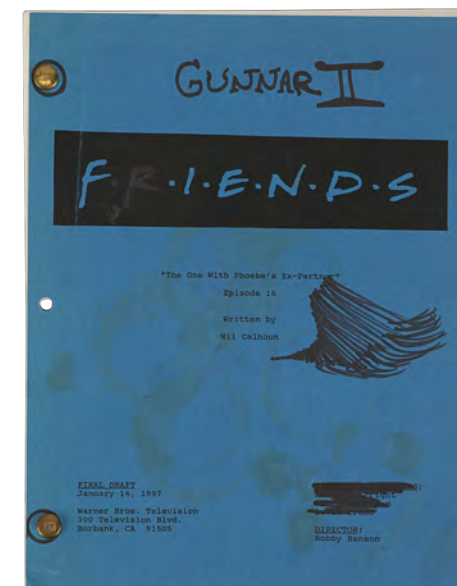
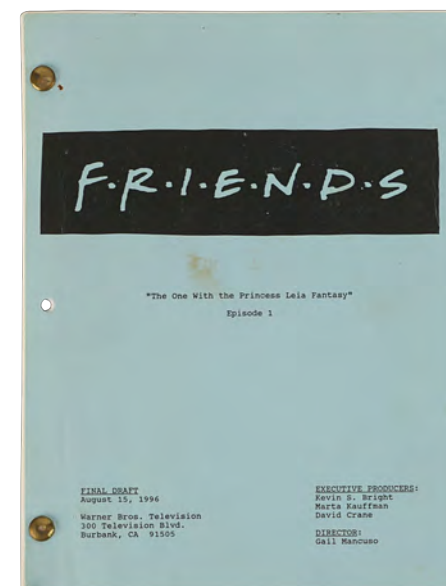

**96**  
**"The One with the Princess Leia Fantasy" and "The One with Phoebe's Ex-Partner" Production Scripts M**  
**Friends - The One with the Princess Leia Fantasy (1996), The One with Phoebe's Ex-Partner (1997)**

Two production scripts from the US sitcom television series Friends.

The 41-page "The One with the Princess Leia Fantasy" script is for the first episode of season three. The episode involved several plot lines, including Ross' fantasy, which is implicit in the title. The 42-page "The One with Phoebe's Ex-Partner" script is for the 14th episode of season three. Interestingly, the script's cover indicates this episode was initially planned as the 16th episode of the same season. The episode notably involved Phoebe reuniting with a partner she used to sing with. "Gunnar 2" and scribbling are handwritten on the script's cover in black marker pen. Both scripts are printed on one-sided A4, bound together with their covers by metal pins. Dimensions: 28.25 cm x 21.75 cm x 1 cm (11" x 8.5" x 0.25")

**Estimate: £2,000 - 4,000**

**97**  
**Seth Gecko's (George Clooney) Screen-matched Jacket and Vest M**  
**From Dusk Till Dawn (1996)**

Seth Gecko's (George Clooney) screen-matched bloodied jacket and vest from Robert Rodriguez's crime horror From Dusk Till Dawn. Seth wore an all-black suit throughout the film, which became increasingly dirty and damaged as the plot progressed.

This jacket has distinctive marks and stains from mud, faux viscera and stage blood which screen-match it to the one seen in the final scene, after Seth escaped the vampires in the Titty Twister bar.

The jacket is a Hugo Boss suit blazer, while the vest is Remi branded. Both items maintain their intentional distressing in the form of dirt stains. The faux viscera and stage blood that remain on the jacket are moist in parts.

**Estimate: £6,000 - 12,000**





**98**  
**US Soldier Helmet m**  
**Full Metal Jacket (1987)**

A US soldier helmet from Stanley Kubrick's Vietnam War film Full Metal Jacket. US soldiers wore their helmets during the second part of Kubrick's masterpiece, during the Battle of Hu? and the cat-and-mouse hunt of the Viet Cong sniper.

This is a genuine period army helmet made of metal with a kevlar inner lining and a cotton camouflage-patterned outer cover. The helmet's interior webbing consists of tough nylon straps and a leather headband on which "33" is handwritten in black marker pen. A chin strap is threaded through two metal clips at the side of the helmet.

The helmet is embellished with slogans, including "Vietnam Crusing [sic]" and "U.S.M.C." handwritten in black ink, and "Fuck Nam" in white ink. It is also intentionally distressed to appear battle-worn with dirt stains and holes in its cotton cover. Dimensions: 28.5 cm x 24.5 cm x 19 cm (11.25" x 9.75" x 7.5")

**Estimate: £4,000 - 8,000**

**99**  
**Hero Unsullied Helmet with Dagger and Gloves m**  
**Game Of Thrones (T.V. Series, 2011-2019)**

A hero Unsullied helmet with a dagger and a pair of gloves from David Benioff and D.B. Weiss' fantasy television series Game of Thrones. The Unsullied wore their helmets and carried daggers throughout their service to Daenerys Targaryen (Emilia Clarke). Black gloves were typically worn by men of the Night's Watch, whose uniform was entirely black.

The helmet is made of leather and metal, with a soft leather top supported by a structural spine of metal through the centre of the crown. It is lined with foam for the wearer's comfort. The dagger is made of resin and painted a gold colour. The gloves are made of black leather. Dimensions (helmet): 43 cm x 27 cm x 27 cm (17" x 10.75" x 10.75")

Edged, bladed or blunt object; see notice on Blades in the Buyer's Guide.

**Estimate: £3,000 - 6,000**



**100**  
**VFX Dragon Head tΔ**  
**Game Of Thrones (T.V. Series, 2011-2019)**

A large VFX dragon head from the production of Game of Thrones. Daenerys Targaryen (Emilia Clarke) had three dragons - Drogon, Rhaegal and Viserion - under her control and used them to cut swathes across Essos and eventually Westeros.

This fibreglass dragon head was used during filming to help the VFX team add in the computer-generated heads at a later date, as well as to provide a lighting reference, and something for the actors to interact with.

The green head has orange tracking markers around the nose, lips, brow and neck. Inside the head there are two metal mounting points. There is some paint wear, especially around the nose. Dimensions: 110 cm x 70 cm x 50 cm (43.25" x 27.5" x 19.75")

**Estimate: £3,000 - 6,000**



**101**  
**Beric Dondarrion's (Richard Dormer) SFX Flaming Sword tΔ**  
**Game Of Thrones (T.V. Series, 2011-2019)**

Beric Dondarrion's (Richard Dormer) SFX flaming sword from the multi-E Emmy-award-winning fantasy TV show Game of Thrones.

Leader of the Brotherhood Without Banners guerrilla resistance, Beric Dondarrion, was prevalent throughout the show's existence, intriguing viewers with his repeated revival at the hands of the Lord of Light and his ability to set his sword aflame with his fire-infused blood. The inflamed weapon became synonymous with his character as he and his comrades looked to defeat various enemies throughout their many appearances.

The metal blade of this SFX sword has been covered, save for the edges, with a textured dura-blanket fabric that was dipped into oil and set alight during filming. Additional SFX patches are found on various parts of the hilt, which is also made of metal. The exhibited production use on the prop, particularly on the covered blade, indicates that the sword was used extensively for scenes where Beric fought with it alight. Dimensions: 106 cm x 23 cm x 3.25 cm (41.75" x 9" x 1.25")

Edged, bladed or blunt object; see notice on Blades in the Buyer's Guide.

**Estimate: £4,000 - 8,000**

**102**  
**Onionhead (Slimer) Maquette Δ**  
**Ghostbusters II (1989)**

An Onionhead maquette from the production of Ivan Reitman's Ghostbusters II. Onionhead - the fan-favourite green ghost also known as Slimer - vexed Louis Tully (Rick Moranis) throughout the film.

This maquette was created by the Industrial Light & Magic (ILM) Creature Shop during pre-production as reference for the puppet, which incorporated several design changes from the ravenous spectre's appearance in the first film. It is cast from plaster and hand-painted in Slimer's signature vomitous green with yellowed eyes and teeth and a pink screaming mouth. The maquette comes mounted to a black wooden base via a metal rod inserted through its bottom. The plaster exhibits minor scratches and flaking along its fingers, while the wood exhibits some minor scuffing. Dimensions: 25.5 cm x 12.75 cm x 20.5 cm (10" x 5" x 8")

**Estimate: £4,000 - 8,000**







Credit Line

**103**  
**Vigo the Carpathian's (Wilhelm von Homburg) Screen-matched Armour m Ghostbusters II (1989)**

Vigo the Carpathian's (Wilhelm von Homburg) screen-matched armour from Ivan Reitman's comedy-horror sequel Ghostbusters II. Vigo wore his armour after he emerged from his portrait and tried to steal Dana's (Sigourney Weaver) baby Oscar. Distinctive markings on the leather chest piece match this armour to the one seen on screen. The Ghostbusters series is one of the most popular comedy series of all time, and has spawned numerous video game, comic and television series spin-offs.

The armour comprises a brown leather chest piece with aluminium studs and skull-shaped adornments; a matching leather belt and skirt; leather bracers (labelled "Left" and "Right"); and leather gauntlets with resin studs on the knuckles. The armour has been intentionally distressed to appear old and worn, and some of the studs have come off.

**Estimate: £15,000 - 30,000**

**104**  
**Animatronic Theatre Ghost Puppet us Ghostbusters II (1989)**

An animatronic theatre ghost puppet from Ivan Reitman's Ghostbusters II. Crowds fled from the movie theatre after an insectoid-like ghost appeared as the pink slime began to overflow in New York City on New Year's Eve.

This animatronic puppet with mechanical and wired insides is covered with foam and latex draped in a black chiffon shroud. It features a rigid plastic skull, as well as reflective eyes and a desiccated muscle-like sculpture. Clear fishing line is attached to the upper back to allow the puppet to fly through the air when attached to a rig.

Following production, this puppet underwent accurate, modern, and high-end restoration to return it to its original 1989 appearance. While it exhibits significant loss of its skin, the remainder has been sympathetically stabilised. The puppet also exhibits discolouration, as well as fragile and crumbling foam, and should be handled with care. Dimensions: 160 cm x 76.25 cm x 30.5 cm (63" x 30" x 12")

Contains electronic and mechanical components; see notice in the Buyer's Guide.

Special shipping required; see notice in the Buyer's Guide.

**Estimate: £3,000 - 6,000**



**105**  
**Light-up Neutrona Wand m Ghostbusters: Frozen Empire (2024)**

A light-up Neutrona wand from Gil Kenan's fantasy-comedy sequel Ghostbusters: Frozen Empire. Ghostbusters used Neutrona wands throughout the film.

The wand is predominantly made of aluminium, with a rubber grip painted to resemble wood and colourful rubber external wires. It features three buttons that turn on seven lights, while an additional button labelled "intensify" brightly illuminates the end of the wand with an eighth light. These lights are powered by eight AA batteries that fit into a compartment accessible by a removable magnetised panel on the underside of the wand.

The display stand accompanying the wand comprises a wooden base and a resin plasma holder labelled "Plasm Sample 1". This wand was originally gifted to the film's production designer, Eve Stewart, whose surname is on the stand's label, which was made from a Ghostbusters overall badge.

The lot also includes two crew beanies with "thank you" cards and a crew cap, all featuring references to the production's code name 'Firehouse'. Dimensions (wand on stand): 60 cm x 22 cm x 25.5 cm (23.5" x 8.75" x 10")

Contains electronics; see electronics notice in the Buyer's Guide.

**Estimate: £5,000 - 10,000**





**106**  
**Maximus Decimus Meridius' (Russell Crowe) Arena**  
**Helmet and Mask** α  
**Gladiator (2000)**

Maximus' (Russell Crowe) arena helmet and mask from Ridley Scott's Oscar®-winning historical epic *Gladiator*. Maximus wore his helmet and mask during the re-enactment of the famous Battle of Carthage, in which he rallied the desperate gladiators against the charioteers, overcoming all odds to achieve a glorious victory.

The helmet is made of fibreglass with embedded metal powder to present as if constructed of metal, and is lined with padded black leather. Blunted spikes adorn the exterior, down the centre of which a pointed fin vertically runs, and a neck guard is incorporated into the back. Shades of dark grey and black are applied to produce a weathered, battle-worn appearance, and there are intentional dents.

Also exhibiting a weathered finish, the fibreglass front section mask has large eye holes, a nose guard and angular detailing. The mask is attached to the helmet via two intricate cast-metal buttons, each decorated with a flower emblem.

Parts of this particular helmet, including the tip of the fin, were sympathetically repaired after being damaged on set. Presented on a custom-made display, the helmet exhibits minor wear on the leather edges and repair work on the front of the fin. Dimensions (displayed): 27 cm x 20 cm x 44 cm (10.5" x 8" x 17.25")

**Estimate: £100,000 - 200,000**



Al Pica / Alamy Stock Photo



Scan here to see a full rotation of this lot

**107**  
**Maximus Decimus Meridius' (Russell Crowe)**  
**Metal Sword and Scabbard**  
**Gladiator (2000)**

General Maximus Decimus Meridius' (Russell Crowe) metal sword and scabbard from Ridley Scott's *Gladiator*. Maximus carried his general's sword and scabbard in the opening battle scenes as he led his Roman army against the Barbarian tribes in the forests of Germania.

*Gladiator* was one of the most successful films of 2000, placing frequently on lists such as *Empire's* 100 Best Movies Of All Time, and won five Academy Awards for Best Picture, Best Actor, Best Visual Effects, Best Sound, and Best Costume Design. It also was nominated for an additional seven categories, as well as five Golden Globes, of which it won two. This sword is made of metal with a wood and resin hilt, and a leather-wrapped wooden scabbard with moulded metal accents. The sword's hilt features brass-colour floral detailing as well as a "SPQR" debossing on the guard, and an off-white grip to resemble ivory inlaid with a copper-colour dinar. The scabbard has an attached leather belt strap. This lot exhibits discoloration, denting, adhesive residue on the scabbard, and discoloration on the sword. Dimensions: 106.75 cm x 10.25 cm x 6.75 cm (42" x 4" x 2.5")

Blade was dulled by production.

Edged, bladed or blunt object; see notice on Blades in the Buyer's Guide.

**Estimate: £40,000 - 80,000**

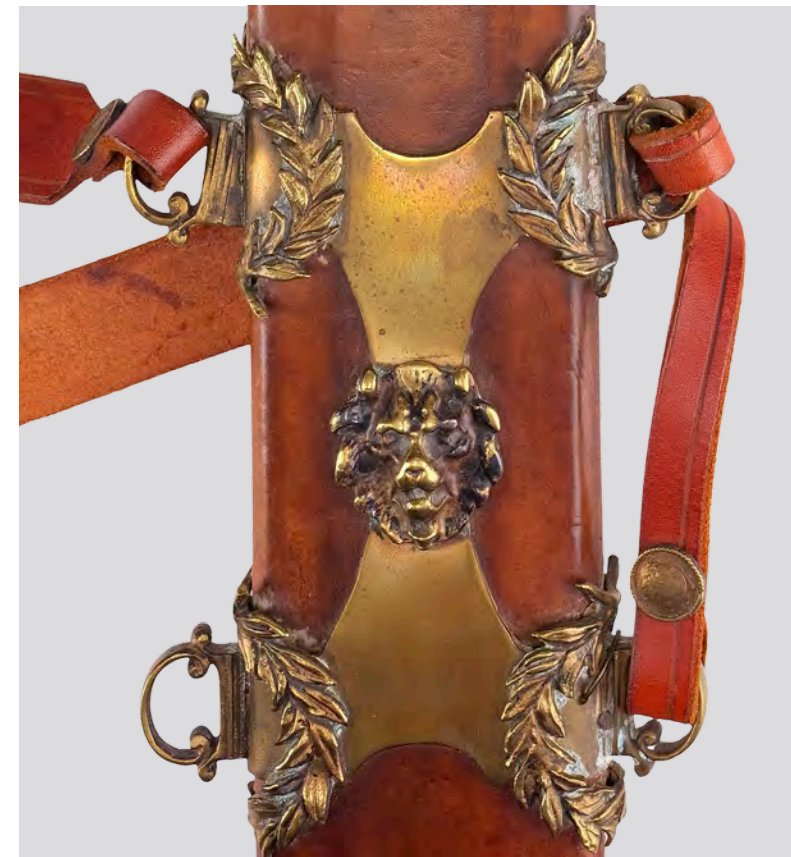



**108**  
**Production-made Commodus' (Joaquin Phoenix)**  
**Arena Cuirass †**  
**Gladiator (2000)**

Commodus' (Joaquin Phoenix) arena cuirass from the production of Ridley Scott's historical epic Gladiator. The Roman emperor wore his white ceremonial arena costume for his final duel with Maximus (Russell Crowe) in the Colosseum.

Constructed of foam urethane, the armour is made in two parts, a front and back plate, attached at the shoulders and waist via buckled leather straps. The elegant chest plate features cast embellishments, including chariot soldiers, winged angels and swirling patterns. There are two diagonal gashes across the chest, representing battle damage.

This piece was created during production, but never painted. It was painted after filming for display purposes. Dimensions: 61 cm x 42 cm x 24.25 cm (24" x 16.5" x 9.5")

**Estimate: £5,000 - 10,000**

**109**  
**Praetorian Guard Costume with**  
**Hero Sword, Pilum and Shield †**  
**Gladiator (2000)**

A complete Praetorian Guard costume with a hero sword, pilum and shield from Ridley Scott's Academy-award winning historical epic Gladiator. The Praetorian Guard, an elite unit of the Imperial Roman Army, served as the personal bodyguards of Emperor Commodus (Joaquin Phoenix).

The costume comprises a foam-padded fibreglass helmet with leather chin straps; plastic lorica segmentata body armour painted to appear metallic, with metal buckles; a purple woollen hooded cloak with matching tunic and trousers; a faux-silver-painted metal-backed resin cloak clasp featuring a lion emblem; a brown leather cingulum with grey plastic armour plating; a pair of plastic bracers; a pair of plastic greaves; and a pair of brown leather boots.

The sword has a metal blade with a wooden hilt finished in black, and a black scabbard with a sling allowing it to be carried at the side. The pilum is made of wood with the spearhead painted to look like metal. The shield covered in black-painted canvas, with leather-and-wooden grips, and a plastic boss. Dimensions (pilum): 231 cm x 9 cm x 9 cm (91" x 3.5" x 3.5")

Edged, bladed or blunt object; see notice on Blades in the Buyer's Guide.

Special shipping required; see special shipping notice in the Buyer's Guide.

**Estimate: £5,000 - 10,000**



**110**  
**Thracian-style Arena Gladiator**  
**Helmet †**  
**Gladiator (2000)**

A Thracian-style arena gladiator's helmet from Ridley Scott's historical epic Gladiator. Maximus (Russell Crowe) teamed up with Juba (Djimon Hounsou) in the Zucchabar arena to kill gladiators adorned with elaborate helmets.

Costume designer Janty Yates won an Academy Award for her work on the film.

The helmet is made of fibreglass painted silver to resemble metal. It features a facemask which opens down the middle and its dome is lined with foam for the wearer's comfort. The helmet has some cracks and wear from production use, most notably on the dome. Dimensions: 53 cm x 52 cm x 49 cm (20.75" x 20.5" x 19.25")

**Estimate: £5,000 - 10,000**



**111**  
**Zucchabar Arena Gladiator Helmet †Δ**  
**Gladiator (2000)**

A Zucchabar arena gladiator helmet from Ridley Scott's Oscar-winning historical epic Gladiator. Gladiators wore their helmets and armour in the arena at Zucchabar during Maximus' (Russell Crowe) first fight, and this helmet was worn by a warrior who fought Maximus' ally Hagen (Ralf Moeller). The helmet is made of fibreglass finished in silver paint to replicate metal, with added intentional distressing to create a battle-worn appearance. It features protective cheek and nose guards, and a neck guard is also attached to the back. Pieces of foam padding are adhered to the interior for comfort purposes. There are visible glue remnants, and some foam has come away over time. Dimensions: 33 cm x 16 cm x 29 cm (13" x 6.25" x 11.5")

**Estimate: £4,000 - 8,000**

## Sell Your Movie Memorabilia

Achieve world record prices for  
entertainment memorabilia

### Indiana Jones and the Temple of Doom (1984)

Indiana Jones' (Harrison Ford)  
Screen-and-Photo-Matched  
Fedora Also Worn by Stunt  
Performer Dean Ferrandini

sold for \$630,000 (£504,000)\*



Reach out for a free appraisal  
and valuation with our specialists



Email: [consign@propstore.com](mailto:consign@propstore.com)  
UK Office: +44 (0) 1494 766485  
US Office: +1 818 727 7829

Scan QR code to visit [propstore.com/props](https://propstore.com/props)



112

### The Costumi d'Arte Collection: Michael Corleone's (Al Pacino) Papal Honours Costume **The Godfather Part III (1990)**

Michael Corleone's (Al Pacino) papal honours costume from Francis Ford Coppola's Mafia crime-drama sequel *The Godfather Part III*. At the film's beginning, Corleone received papal honours in a church, while haunted by guilt for his ruthless past actions. This lot comes from the archives of the Italian costume company Costumi d'Arte.

The costume comprises a black cotton jacket with red velvet trim and a nylon inner lining, and a pair of black cotton trousers with gold-coloured patterned trim. The jacket features resin buttons finished to look like gold. The velvet trim at the collar, rear and cuffs is adorned with olive branch patterns, which are made of cord and further embellished with plastic. A costume label inside the trousers has "Oneguine" handwritten on it in blue ink.

**Estimate: £5,000 - 10,000**





**113**  
**The Costumi d'Arte Collection: Blondie's (Clint Eastwood) Duster Coat**  
**The Good, The Bad And The Ugly (1966)**

Blondie's (Clint Eastwood) duster coat from Sergio Leone's classic epic Western *The Good, the Bad and the Ugly*.

Blondie - aka The Man With No Name - wore his duster during the first part of the film, as he teamed up with wanted criminal Tuco (Eli Wallach) to collect Tuco's bounty and then free him from multiple hangings. This lot comes from the archives of the Italian costume company Costumi d'Arte.

Although it initially met with mixed reviews, the film is considered by many to be the greatest Western of all time, and it catapulted Eastwood to movie superstardom. This was Eastwood's third time playing The Man With No Name, following Leone's *A Fistful of Dollars* and *For a Few Dollars More*.

Dusters are an iconic Western garment, and Leone was a particular fan, with costume designer Carlo Simi reporting that "dusters were a mania of his". Quentin Tarantino, meanwhile, recounted that "Leone once said they were like a suit of armour".

The beige double-breasted duster features two chest pockets and two slash pockets, which feature prominently as part of Blondie's quick-draw action. This item is likely to have been rented to numerous productions over the decades since filming. Some minor modifications and repairs may have taken place during that time. There is some wear from production use, including minor staining, discolouration and plucking.

**Estimate: £60,000 - 120,000**



TCD/Prod.DB / Allamy Stock Photo



Allstar Picture Library Limited. / Alamy Stock Photo

**114**  
 The Costumi D'Arte Collection: Blondie's  
 (Clint Eastwood) Shirt ◊  
**The Good, The Bad And The Ugly (1966)**

Blondie's (Clint Eastwood) shirt from Sergio Leone's classic epic Western *The Good, the Bad and the Ugly*. Blondie – aka *The Man With No Name* – wore his distinctive black and white patterned shirt during the first half of the film, from the shooting of three bounty hunters to the stagecoach scenes in the desert. He also wore his shirt in the memorable scene where Tuco (Eli Wallach) returns to try and hang Blondie. Eastwood wore two slightly different styles of this shirt in the film – one with pleated pockets and one with flat pockets – and this is the flat-pocket style. This lot comes from the archives of the Italian costume company Costumi d'Arte.

Although the film initially met with mixed reviews, it is considered by many to be the greatest Western of all time, and it catapulted Eastwood to movie superstardom. This was Eastwood's third and final time playing *The Man With No Name*, following Leone's *A Fistful of Dollars* and *For a Few Dollars More*.

The black cotton shirt has an interior label from Italian costume supplier Costumi d'Arte Peruzzi. It features two chest pockets, a grandad-style collar, and a white circles-and-spots pattern. This item is likely to have been rented to numerous productions over the decades since filming. Some minor modifications may have taken place during that time and the shirt has been repaired in several places since the production.

**Estimate: £40,000 - 80,000**





**115**  
The Costumi d'Arte Collection: Stunt Tuco Sombrero  $\Omega$   
**The Good, The Bad And The Ugly (1966)**

A stunt Tuco sombrero from Sergio Leone's classic epic Western *The Good, the Bad and the Ugly*. Tuco (Eli Wallach) stole his sombrero, along with a gun and \$200, from the Storekeeper (Enzo Petito) as he sought his revenge on Blondie (Clint Eastwood). He wore the sombrero until he and Blondie disguised themselves as Confederate soldiers, most notably when he attempted to hang Blondie, before the building they were in was destroyed by cannon fire. This lot comes from the archives of the Italian costume company Costumi d'Arte.

Although it initially met with mixed reviews, the film is considered by many to be the greatest Western of all time. Wallach was a veteran of Westerns by the time he made the film, but the role of Tuco, aka The Ugly, was the most iconic of his long and illustrious career.

This straw hat was made for the production but differs very slightly from the ones seen on screen worn by Eli Wallach. It was likely worn by Wallach's stunt double Luigi Ciavarrò. The crown features a leather eagle decoration, based on the Mexican national emblem, and the sombrero has leather around its brim edge, with a leather chinstrap. The hat has wear from use and age, most notably tearing around the base of the dome. Some of the leather decorations are no longer present, and the leather has shrunk over time.

**Estimate: £10,000 - 20,000**



ScreenProd / Photonostop / Alamy Stock Photo



**116**  
Walt's (Clint Eastwood) Ranger Zippo Lighter  $\mu$   
**Gran Torino (2008)**

Walt's (Clint Eastwood) ranger zippo lighter from Eastwood's acclaimed 2008 drama *Gran Torino*.

Walt lit cigarettes throughout the film with his Zippo, and also used it as a decoy for a gun in the final scenes. He tricked the Hmong gang who terrorised his neighbours Thao (Bee Vang) and Sue (Ahney Her) into shooting him dead, causing them to get sent down for murder.

The metal lighter features a sticker with the yellow-and-black emblem of the US 1st Cavalry Division, in which Walt served during the Korean War. The lighter is sold unfuelled, its spark remains functional. Dimensions: 1.5 cm x 4 cm x 5.75 cm (0.5" x 1.5" x 2.25")

**Estimate: £5,000 - 10,000**



**117**  
The Costumi d'Arte Collection: Sheriff Clayton's  
(Lee Van Cleef) Screen-matched Costume  $\Omega$   
**The Grand Duel (1972)**

Sheriff Clayton's (Lee Van Cleef) screen-matched costume from Giancarlo Santi's spaghetti Western *The Grand Duel*. Clayton wore his costume throughout the film, as he sought justice for Philip Wermeer (Alberto Dentice), a man wrongly accused of murder. The trousers screen match the climatic duelling scene through the placement of the pinstripes. This lot comes from the archives of the Italian costume company Costumi d'Arte.

The costume comprises a black satin frock coat with a suede collar and a handwritten label in the neckline reading "Liy Van Clyft [sic]"; a black corduroy waistcoat labelled "Liy Van Clyft [sic]"; and a pair of black trousers with white pinstripes labelled "Liy Van Clyft [sic]". Each clothing item has interior labels from Italian costume supplier Costumi d'Arte Peruzzi. The costume pieces have some very minor discolouration.

**Estimate: £5,000 - 10,000**





68.5 cm  
(27")

**118**  
Gremlin Puppet  $\Omega$   
**Gremlins (1984)**

A gremlin puppet from Joe Dante's *Gremlins*. Chaos ensued after Billy Peltzer's (Zach Galligan) mogwai, Gizmo, multiplied and transformed into mischievous gremlins that wreaked havoc through town.

Dante won the Best Director 1985 Saturn Award for a film whose depictions of violence helped spur the creation of the PG-13 rating within the Motion Picture Association of America's system, and also inspired various films within the subgenre dealing with antagonistic small monsters. The film is considered among the greatest science-fiction comedies of all time as well as a classic of 1980s American cinema.

This and all of the creature puppets were designed by legendary effects artist Chris Walas. While puppets from the sequel remain in some private collections, surviving puppets from the first film are exceedingly rare.

Made from foam and latex, the gremlin is moulded around an interior metal rod and painted in shades of brown, green, and yellow. It has red and orange acrylic eyes and pointed yellow teeth. The puppet has undergone sympathetic restoration, most notably to repair damage on the chest, neck, and wrists as well as to reblend paint around the repairs. Additionally, new armature wire was installed in its ears to keep them upright. Also included is a custom metal display stand. This puppet's original puppeteering hole on its back left shoulder remains open from production, and as it exhibits foam fragility, it should be handled with care. Dimensions: 43.25 cm x 24.25 cm x 68.5 cm (17" x 9.5" x 27")

**Estimate: £25,000 - 50,000**



**119**  
**Gremlin Puppet Replica from Original Moulds us**  
**Gremlins (1984)**

A gremlin puppet replica made from original puppet moulds from the production of Joe Dante's Gremlins. In the film, chaos ensued after Billy Peltzer's (Zach Galligan) mogwai, Gizmo, multiplied and transformed into mischievous gremlins that wreaked havoc through town.

Dante won the Best Director 1985 Saturn Award for a film whose depictions of violence helped spur the creation of the PG-13 rating within the Motion Picture Association of America's system, and also inspired various films within the subgenre dealing with antagonistic small monsters. The film is considered among the greatest science-fiction comedies of all time as well as a classic of 1980s American cinema.

Created from original puppet moulds made for the production, this gremlin is cast in a rigid lightweight foam for longevity with interior wood rod supports. It features large upright ears, detailed orange and yellow eyes, acrylic teeth, and is painted in shades of brown, green, and yellow on its body. The piece has undergone sympathetic restoration, most notably to reattach limbs and to reblend its paint. This lot exhibits fragility and should be handled with care. Dimensions: 53.5 cm x 81.25 cm x 51 cm (21" x 32" x 20")

**Estimate: £5,000 - 10,000**



**120**  
**Daffy Mogwai Display**  
**Gremlins 2: The New Batch (1990)**

A display of the Mogwai known as Daffy from Joe Dante's horror-comedy sequel Gremlins 2: The New Batch. Daffy was one of a group of Gremlins who terrorised the Clamp Centre building.

Mogwai puppets were created by multi-Academy Award-winning special-effects artist Rick Baker's Cinovation Studios, and used for the film's early scenes, when the characters needed to be viewed in full. This puppet has been professionally reassembled using Baker's original production-made parts.

The puppet's hands, feet, mouth and ears are made of foam latex and are attached to a body covered in orange, white and black faux fur. It has acrylic eyes, and its foam latex skin is fully painted and displays a high level of detail, with painted fingernails and toenails.

The puppet is presented on a custom-made display stand comprising an acrylic rod attached to a wooden base with plastic cladding. Eight 1.5V AA batteries power the stand, which lights up. The puppet's hands and mouth exhibit hardening and minor cracking. Dimensions (displayed): 15.75 cm x 35 cm x 50 cm (6.25" x 13.75" x 19.75")

Contains electronics; see electronics notice in the Buyer's Guide.

**Estimate: £12,500 - 25,000**

**121**  
**George Mogwai Display**   
**Gremlins 2: The New Batch (1990)**

A display of the Mogwai known as George from Joe Dante's horror-comedy sequel *Gremlins 2: The New Batch*. After water accidentally spilled on Gizmo in the Clamp Enterprises office, he spawned a number of new Mogwai, including George.

Mogwai puppets were created by multiple Academy Award-winning special-effects artist Rick Baker's Cinovation Studios, and used for the film's early scenes when the character needed to be viewed in full. This puppet has been professionally reassembled using Baker's original production-made parts.

The puppet's hands, mouth and ears are made of foam latex, while its mechanical body is covered with brown, white and black faux fur. It has acrylic eyes, and its foam latex skin is painted in a high level of detail, including fingernails and toenails. The body has a metal armature, which is connected to two cables for controlling the puppet's arms.

The lot is presented on a custom-made light-up display stand powered by eight 1.5V AA batteries. It is made of wood with plastic cladding. The squeeze trigger cable for the puppet's left arm has snapped and is currently inoperable. The hands exhibit hardening and cracking, revealing the mechanical fingers underneath. The mouth also exhibits cracking. Dimensions (displayed): 17.5 cm x 34.5 cm x 46.5 cm (7" x 13.5" x 18.25")

Contains electronics; see electronics notice in the Buyer's Guide.

Contains mechanical components; see mechanical notice in the Buyer's Guide.

**Estimate: £10,000 - 20,000**



**122**  
**Mohawk Mogwai Display**   
**Gremlins 2: The New Batch (1990)**

A display of the Mogwai known as Mohawk from Joe Dante's horror-comedy sequel *Gremlins 2: The New Batch*. After water accidentally spilled on Gizmo in the Clamp Enterprises office, he spawned a number of new Mogwai, including Mohawk.

Mogwai puppets were created by multiple Academy Award-winning special-effects artist Rick Baker's Cinovation Studios, and used for the film's early scenes when the character needed to be viewed in full. This puppet has been professionally reassembled using Baker's original production-made parts.

The puppet's hands, feet, mouth and ears are made of foam latex and attached to a body covered in brown, white and black faux fur. It has acrylic eyes and its foam latex skin is fully painted in a high level of detail, including fingernails and toenails.

The puppet is presented on a custom-made display stand comprising an acrylic rod attached to a wooden base with plastic cladding. Eight 1.5 V AA batteries power the stand, which lights up. The puppet's top lip exhibits a chip in the foam latex. Dimensions: 15.5 cm x 35 cm x 52 cm (6" x 13.75" x 20.5")

Contains electronics; see electronics notice in the Buyer's Guide.

**Estimate: £10,000 - 20,000**



**123**  
**Screen-Matched Cable-Controlled**  
**SFX Melting Brain Gremlin Puppet**   
**Gremlins 2: The New Batch (1990)**

A screen-matched cable-controlled SFX melting Brain Gremlin puppet from Joe Dante's *Gremlins 2: The New Batch*. The Brain Gremlin donned human clothes and learned to speak after it consumed Dr. Catheter's (Christopher Lee) brain hormone. Details in this puppet's left ear, including cuts and patterns, screen-match to insert shots of the Brain Gremlin being electrocuted and starting to melt in the film's finale.

Created by Rick Baker's Cinovation Studios, this puppet is constructed of foam latex moulded around polyfoam with a mesh lining, metal armature, and acrylic eyes. The puppet is hand-painted brown with black spots and green oozing pustules on its back where embryos were forming from the Gremlins having been sprayed with a fire hose just prior to electrocution. It has wire and rubber cables for servo-control that extend outside the body through the back and are attached to metal and plastic control sticks. This puppet comes mounted to a wood and metal base for stability, and has gone through extensive sympathetic repairs to the foam and latex. This lot exhibits cracked latex and exposed foam, which has become fragile with age, and should be handled with care. Dimensions: 68.5 cm x 43.25 cm x 38 cm (27" x 17" x 15")

Contains mechanical components; see notice in the Buyer's Guide.

**Estimate: £10,000 - 20,000**





**124**  
George Gremlin Final Paint Bust  $\Omega$   
**Gremlins 2: The New Batch (1990)**

A final paint bust of the Gremlin known as George from Joe Dante's horror-comedy sequel Gremlins 2: The New Batch.

Created by Rick Baker and his team, this lot comprises a final paint test for the gremlin George. This grumpy creature appeared several times during the film, most notably in the scenes where he terrorised the cooking show "Microwave with Marge" and in the toy store where he smoked a cigar and tortured Gizmo.

Constructed from foam and painted green, black and brown in a reptilian pattern, this bust has acrylic eyes and features George's signature sinister scowl. It also has small foam spikes on the top of the head and around the eyes and cheeks. The lot comes with a certificate of authenticity signed by Rick Baker. The bust exhibits mild paint cracking from age but otherwise remains in very good condition. Dimensions: 26 cm x 24 cm x 24 cm (10.25" x 9.5" x 9.5")

**Estimate: £5,000 - 10,000**



**125**  
Lenny Gremlin Final Paint Bust  $\Omega$   
**Gremlins 2: The New Batch (1990)**

A final paint bust of the Gremlin known as Lenny from Joe Dante's horror-comedy sequel Gremlins 2: The New Batch. Created by Rick Baker and his team, this lot comprises a final paint test for the Gremlin version of Lenny, who appeared several times during the film, most notably in the scenes where he terrorised the cooking show "Microwave with Marge."

Made of foam and painted black and brown in a reptilian pattern, this bust features Lenny's signature bucked teeth and dopey eyes. Foam spikes run down the back of the neck, and the eyes are made of acrylic. The foam around the bottom of the bust remains unpainted. The lot also comes with a certificate of authenticity, signed by Rick Baker. The bust exhibits mild paint cracking from age, but otherwise remains in very good condition. Dimensions: 35 cm x 32 cm x 27 cm (13.75" x 12.75" x 10.75")

**Estimate: £5,000 - 10,000**



**126**  
Gizmo Prototype Head  $\Omega$   
**Gremlins 2: The New Batch (1990)**

A Gizmo prototype head from the production of Joe Dante's horror-comedy sequel Gremlins 2: The New Batch. After scientists captured Gizmo at a laboratory in the Clamp Centre, the building was infested by a fresh batch of Gremlins.

Effects artist Chris Walas originally designed and built Gizmo and the Gremlins for the first film. For Gremlins 2, Rick Baker's Cinovation Studios came in to handle the effects work and slightly revised the character designs. During pre-production, the studio made maquettes and prototypes to conceptualise Gizmo's updated look.

This prototype comprises a plaster head covered in faux fur, with foam latex ears and glazed eyes. Its nose, mouth, eyelids and ears are all painted pale pink. The head is affixed to a custom display stand comprising a metal pipe and a grey-painted wooden base. The lot is accompanied by a certificate of authenticity from Rick Baker.

The head exhibits chips in the mouth area. Dimensions: 23 cm x 27 cm x 27 (9" x 10.75" x 10.75")

**Estimate: £4,000 - 8,000**

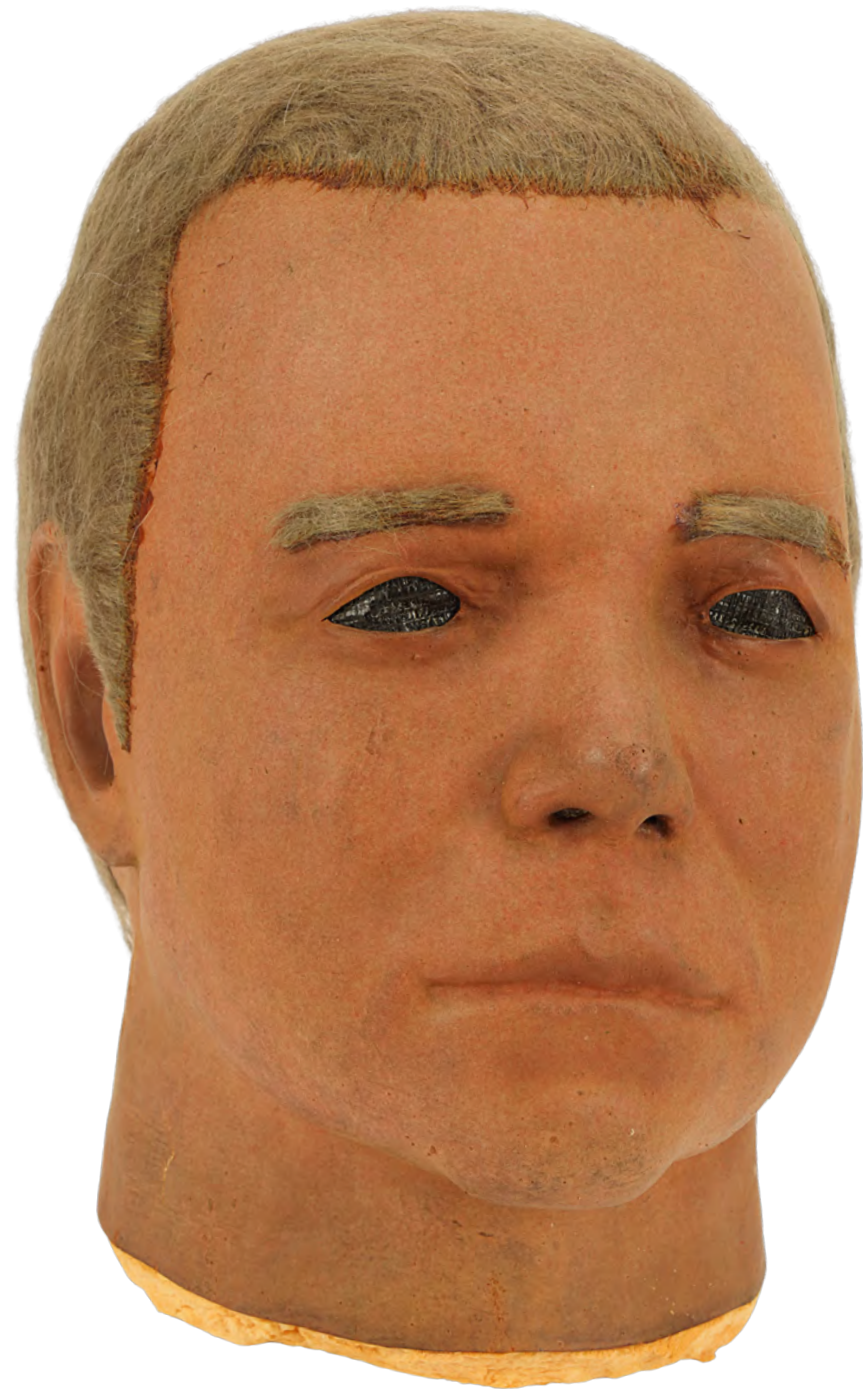

**127**  
 Original 1975 Don Post Studios Captain Kirk (William Shatner) Mask of Style Seen in John Carpenter's Halloween  
**Don Post Studios**

An original 1975 Don Post Studios Captain Kirk (William Shatner) mask. These masks were made famous by John Carpenter's horror movie Halloween. In the first instalment of this influential, decades-spanning horror series, Michael Myers, aka The Shape (Nick Castle), went on a murderous rampage in his hometown of Haddonfield after escaping a sanitarium. Myers wore his iconic mask as he stabbed and strangled his victims throughout the film.

Carpenter used a Captain Kirk mask for both Halloween and Halloween II, altering the design by painting it white, adding faux hair at the back of the scalp, and cutting out larger eye holes in the face.

This is an original 1975 Don Post Studios mask, made from a lifecast of William Shatner, who played Kirk in Star Trek, and its excellent condition makes it an incredibly rare piece, revered by Halloween's fans who have studied it intensely. This specific mask was not used on the film and as such it maintains all of its Captain Kirk features, as it has not undergone the alteration process to become a Michael Myers mask. The Captain Kirk mask was discontinued by the studios in 1976, and this one has since been foam-filled for display purposes. Dimensions: 24 cm x 17 cm x 28 cm (9.5" x 6.75" x 11")

**Estimate: £15,000 - 30,000**



**128**  
 Michael Myers' (Brad Loree) Burnt Mask from Halloween: Resurrection (2002)

Michael Myers' (Brad Loree) burnt mask from Rick Rosenthal's slasher sequel Halloween: Resurrection. In the film's final scene, a coroner unzipped Myers' body bag, revealing his burnt, melted mask, before the killer's eyes suddenly opened. In the alternative "Axe" ending, Myers' burnt mask was revealed to Sara (Bianca Kajlich) and Freddie (Busta Rhymes) as Myers lay seemingly dead on a gurney outside the burned-down house.

The slip latex mask is painted white and features intentional distressing. There are holes in the chin and under the left eye, and latex hand-painted in reds, greens and browns is applied across the back of the head, on the crown and over the eyes to create the effect of melting.

The mask is presented on a black hand-painted foam bust, and comes with a certificate of authenticity from special make-up effects creator Gary J Tunnicliffe. Dimensions: 27 cm x 40 cm x 35 cm (10.75" x 15.75" x 13.75")

**Estimate: £15,000 - 30,000**



# THE RAY & DIANA HARRYHAUSEN FOUNDATION COLLECTION

Ray Harryhausen (1920-2013) was a British-American animator and special effects artist who pioneered a form of stop-motion animation called "Dynamotion". Cinematic luminaries such as Steven Spielberg, Peter Jackson, George Lucas, and James Cameron hailed Harryhausen and his work as massive inspirations for their work and careers. His work on Jason and the Argonauts, One Million Years B.C., The Valley of Gwangi, The Golden Voyage of Sinbad and Clash of the Titans (to name but a few) is the stuff of cinematic legend, with the sword fight with seven skeletons in Jason and the Argonauts being a particular highlight.

The Ray & Diana Harryhausen Foundation (Charity no SC001419) is a charitable Trust set up by Harryhausen on the 10th April 1986. The Foundation's primary aim is to protect Ray's name and body of work and to archive, preserve, and restore Ray's extensive collection. In addition, the Foundation is firmly committed to showing and exhibiting, for educational and entertainment purposes, all of Ray's unique collection, including the short films and his feature productions.

Since Harryhausen's death on the 7th May 2013, and the acquisition of Harryhausen's entire collection by the Foundation, the Trustees have been committed to continuing Harryhausen's hopes for the future and protecting and conserving Harryhausen's name and his unique reputation and contribution to film history. It is estimated that there are over 50,000 items in the collection, including original armatured models, hard rubber stand-in models, armatures, original moulds, original artwork, original miniatures, stills, negatives, original equipment, paperwork, screenplays, various test and dailies footage.

Proceeds from this auction will be used to assist with the Foundation's future projects, including the ongoing preservation of Harryhausen's creature collection. Each lot will be accompanied by a certificate of authenticity co-signed by Vanessa Harryhausen, daughter of Ray and Diana and trustee of the Ray & Diana Harryhausen Foundation.



Scan here to see a full rotation of this lot

## 129 Ray Harryhausen Archive: Lighting Stand-in Hydra Head and Neck by Ray Harryhausen M Jason And The Argonauts (1963)

A lighting stand-in Hydra head and neck made by Ray Harryhausen for the production of Don Chaffey's fantasy adventure Jason and the Argonauts. Acastus (Gary Raymond) is killed by the multi-headed Hydra when he tries to steal the golden fleece before Jason (Todd Armstrong) eventually defeats the monster. This lot comes from Harryhausen's personal collection.

Harryhausen considered the seven-headed Hydra to be one of the most difficult models he ever worked on, given the number of heads involved in the animation process.

This Hydra head and neck was made in 1962 and used as a lighting stand-in during tests. It is made of hard rubber over a flexible metal support and was created as a cast from the original animation model, then hand-painted to be similarly detailed. It has been given a protective coating by the Archive to preserve it from light and the atmosphere. Dimensions: 13 cm x 9 cm x 20 cm (5" x 3.5" x 7.75")

**Estimate: £25,000 - 50,000**



TCD/Prod.DB / Alamy Stock Photo



20 cm (7.75")

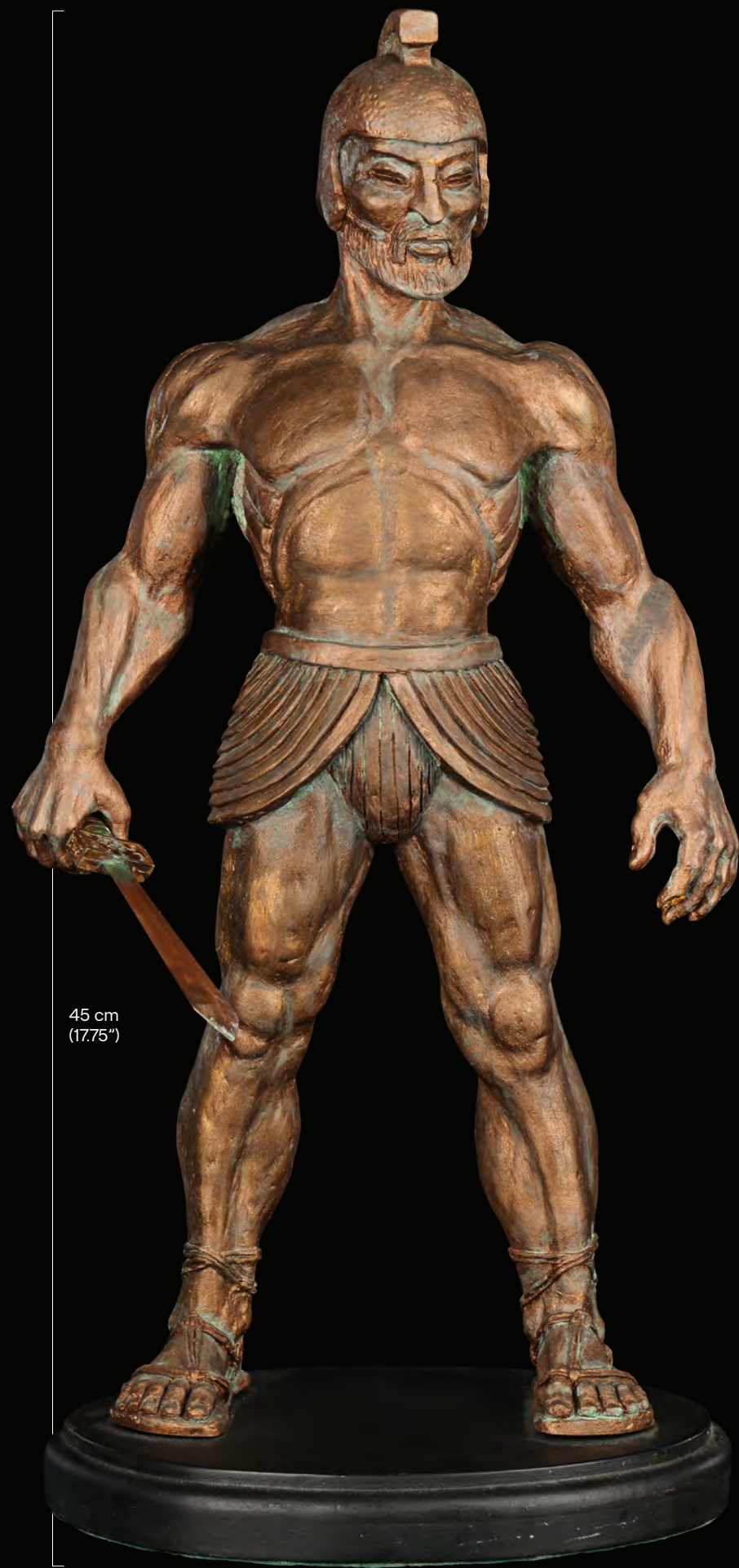

45 cm (17.75")

**130**  
 Ray Harryhausen Archive:  
 Talos Preservation Casting by  
 Ray Harryhausen M  
**Jason And The Argonauts (1963)**

A preservation casting of Talos created by Ray Harryhausen, from Don Chaffey's fantasy adventure Jason and the Argonauts. Talos was a huge bronze statue on the Isle of Bronze, which came alive and attacked the Argonauts after Hercules (Nigel Green) stole some treasure. This lot comes from Harryhausen's personal collection.

Following his retirement, Harryhausen decided to create longer-lasting preservation castings of some of his key models, which were at higher risk of deterioration over time. This resin model, unique to Harryhausen's archive, was created from a sculpture of Talos made by Harryhausen during the 1980s, and cast from the same mould that was used for several bronzes in the same period.

This resin model has been painted to look bronze with a verdigris patina. It comes with a sword which slots into Talos' hand, also built by Harryhausen for the model, and is mounted on a stand. The sword exhibits some paint wear around the handle. Dimensions: 45 cm x 23 cm x 17 cm (17.75" x 9" x 6.75")

**Estimate: £10,000 - 20,000**



Scan here to see a full rotation of this lot



TCD/Prod.DB / Alamy Stock Photo

**131**  
 Ray Harryhausen Archive:  
 Ray Harryhausen's Personal Photo  
 Archive Reference Stills M  
**Jason And The Argonauts (1963)**

Five of Ray Harryhausen's reference stills from the production of Don Chaffey's fantasy adventure Jason and the Argonauts. This lot comes from Harryhausen's personal collection.

This set comprises two black-and-white photographs and three printed illustrations by Harryhausen. The photos show the iconic skeleton scene and the Argonauts being chased by the statue of Talos; the illustrations depict an attack by Triton, Jason (Todd Armstrong) and Medea (Nancy Kovak) in the Underworld, and a meeting with Cerberus, the last of which did not appear in the final film. All of the stills have the film's title handwritten by Harryhausen on the back and three have additional handwritten notes. Dimensions (largest): 21.5 cm x 28 cm (8.5" x 11")

Sold without copyright; see copyright notice in the Buyer's Guide.

**Estimate: £1,000 - 2,000**



THE TITAN AND THE CLASHING ROCKS



**132**  
 Ray Harryhausen Archive:  
 Ray Harryhausen's Personal Photo  
 Archive Reference Stills M  
**The 7th Voyage Of Sinbad (1958)**

Six of Ray Harryhausen's reference stills from the production of Nathan H. Juran's fantasy adventure The 7th Voyage of Sinbad. This lot comes from Harryhausen's personal collection.

This set comprises two behind-the-scenes images, both featuring Harryhausen with some of his models, and four black-and-white stills, two of which feature the cyclops and the roc.

Each still features the film's title handwritten by Harryhausen on the back, and the image of Harryhausen and four of his models is labelled "Ray H and Models" in Harryhausen's hand. Dimensions (largest): 20.5 cm x 25.5 cm (8" x 10")

Sold without copyright; see copyright notice in the Buyer's Guide.

**Estimate: £1,000 - 2,000**



28 cm (11")

**133**  
 Ray Harryhausen Archive:  
 Pinky the Elephant Test Casting by Ray Harryhausen m  
**The Valley Of Gwangi (1969)**

A Pinky the Elephant test casting by Ray Harryhausen from the production of Jim O'Connolly's fantasy Western The Valley of Gwangi. Gwangi, a captured Allosaurus, fought and killed a circus elephant before rampaging through the town. This lot comes from Harryhausen's personal collection.

The elephant, affectionately known as "Pinky", was initially intended to be a live elephant during filming, before adding the animated Gwangi model to its scenes. However, during filming in Almeria, Spain, the elephant turned out to be half the required size, requiring an additional latex armatured model to be built. This piece survives from test castings made during production and was made with the original moulds which cast the final puppet.

The casting is made of hard rubber and has been given a protective coating by the Archive, to preserve it from light and the atmosphere. It is hollow and was not cast with ears or a tail. The model has some minor discolouration and staining. Dimensions: 24 cm x 13 cm x 28 cm (9.5" x 5" x 11")

**Estimate: £20,000 - 40,000**



Scan here to see a full rotation of this lot

**134**  
 Ray Harryhausen Archive:  
 Ray Harryhausen Hand-drawn  
 Gwangi and Elephant Sketch m  
**The Valley Of Gwangi (1969)**

A Ray Harryhausen hand-drawn Gwangi and elephant sketch from the production of Jim O'Connolly's fantasy Western The Valley of Gwangi. This lot comes from Harryhausen's personal collection.

The artwork is a sketch created during production, depicting the battle between the Allosaurus Gwangi and the elephant, the latter of which appeared in the film as a stop-motion creature. The sketch is rendered in pencil, and depicts Gwangi in its cage, with the elephant attempting to get in. The paper exhibits some minor discolouration, and there is a tear on one side, though this does not disrupt the image. Dimensions: 38 cm x 50 cm (15" x 19.75")

Sold without copyright; see copyright notice in the Buyer's Guide.

**Estimate: £5,000 - 10,000**

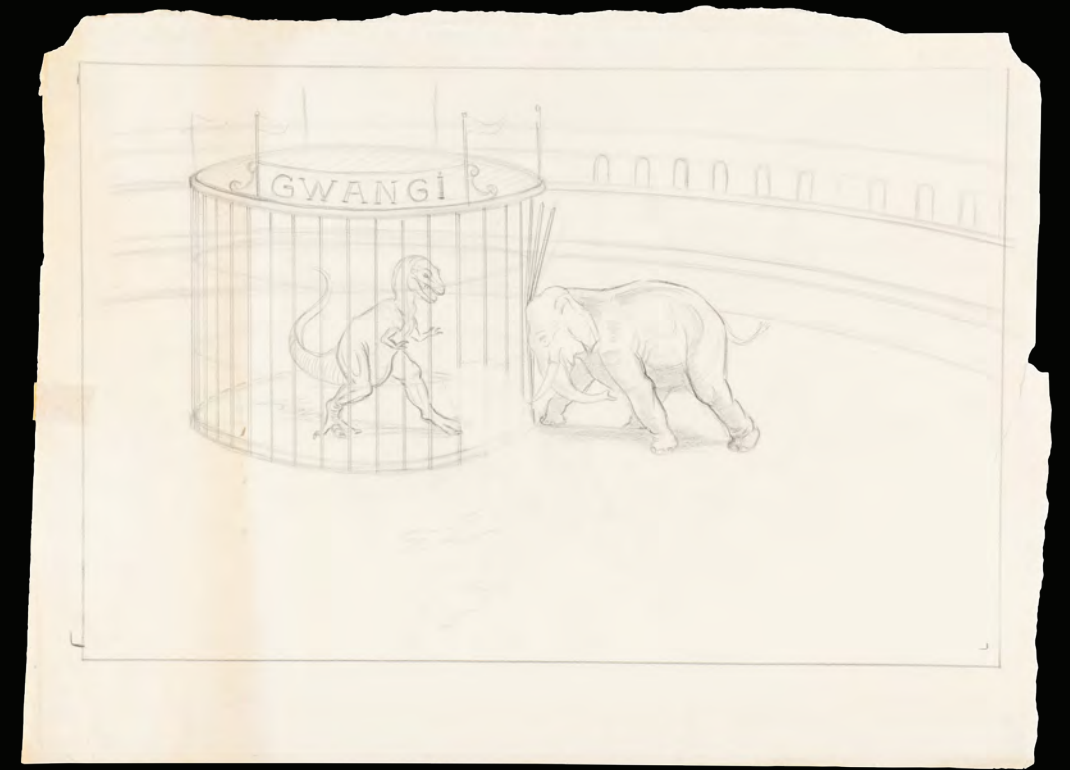

50 cm (19.75")



60 cm (23.75")

**135**  
 Ray Harryhausen Archive:  
 Ray Harryhausen Hand-drawn  
 Cowboy Chasing Ornithomimus  
 Tracing Sketch m  
**The Valley Of Gwangi (1969)**

A Ray Harryhausen hand-drawn sketch of a cowboy chasing an Ornithomimus from the production of Jim O'Connolly's fantasy Western The Valley of Gwangi. This lot comes from Harryhausen's personal collection.

The artwork is a sketch depicting a cowboy chasing an Ornithomimus. This creature was used by Harryhausen as a way of introducing the film's titular Allosaurus in a dramatic fashion: the Ornithomimus is chased into the jaws of Gwangi, who then chases the cowboys. The sketch is rendered in pencil on tracing paper. The paper exhibits some minor discolouration from age, and a tear on one edge that does not disrupt the image. Dimensions: 49 cm x 60 cm (19.25" x 23.75")

Sold without copyright; see copyright notice in the Buyer's Guide.

**Estimate: £5,000 - 10,000**



**136**  
Ray Harryhausen Archive:  
Ray Harryhausen Hand-drawn  
Sketch of Gwangi Attacking  
Styracosaurus m  
**The Valley Of Gwangi (1969)**

A Ray Harryhausen hand-drawn sketch of the Allosaurus Gwangi attacking a Styracosaurus, from the production of Jim O'Connolly's fantasy Western The Valley of Gwangi. This lot comes from Harryhausen's personal collection.

The artwork is a sketch of a key drawing created during production, depicting Gwangi attacking the Styracosaurus, and a cowboy on a horse attempting to intervene. Stills from the movie show just how closely Harryhausen's sketches were followed during filming. The sketch is rendered in pencil.

The paper exhibits some minor discolouration from age. Dimensions: 38 cm x 50 cm (15" x 19.75")

Sold without copyright; see copyright notice in the Buyer's Guide.

**Estimate: £5,000 - 10,000**



50 cm (19.75")

**137**  
Ray Harryhausen Archive:  
Ray Harryhausen Hand-drawn  
Sketch of Pteranodon Lifting  
Cowboy off Horse m  
**The Valley Of Gwangi (1969)**

A Ray Harryhausen hand-drawn sketch of a cowboy being snatched by a Pteranodon, from the production of Jim O'Connolly's fantasy Western The Valley of Gwangi. This lot comes from Harryhausen's personal collection.

This artwork is a sketch of a key drawing created during production, depicting the entrance of the cowboys into the forbidden valley, and Lope (Curtis Arden) being lifted off his horse by a Pteranodon. This sequence shows the first battle between humans and prehistoric creatures in the film, and the moment was achieved by lifting Arden into the air via a crane cable, with Harryhausen later animating the Pteranodon to correspond with his movements. The drawing is rendered in pencil on paper. The edges of the paper are torn, but none of the tears disrupt the image. Dimensions: 35.5 cm x 49 cm (14" x 19.25")

Sold without copyright; see copyright notice in the Buyer's Guide.

**Estimate: £5,000 - 10,000**



49 cm (19.25")



**138**  
Ray Harryhausen Archive:  
Ray Harryhausen's Personal Release Script m  
**The Valley Of Gwangi (1969)**

Ray Harryhausen's personal release script from Jim O'Connolly's fantasy Western The Valley of Gwangi. This lot comes from Harryhausen's personal collection.

The script is dated "April, 1969" and features a detailed breakdown of which dialogue, sounds and scenes should feature on each of the film's 10 reels. Release scripts are also used internationally to help with dubbing and subtitling. The script is bound with metal fasteners between red card covers. Dimensions: 33.5 cm x 21 cm x 2 cm (13.25" x 8.25" x 0.75")

**Estimate: £5,000 - 10,000**

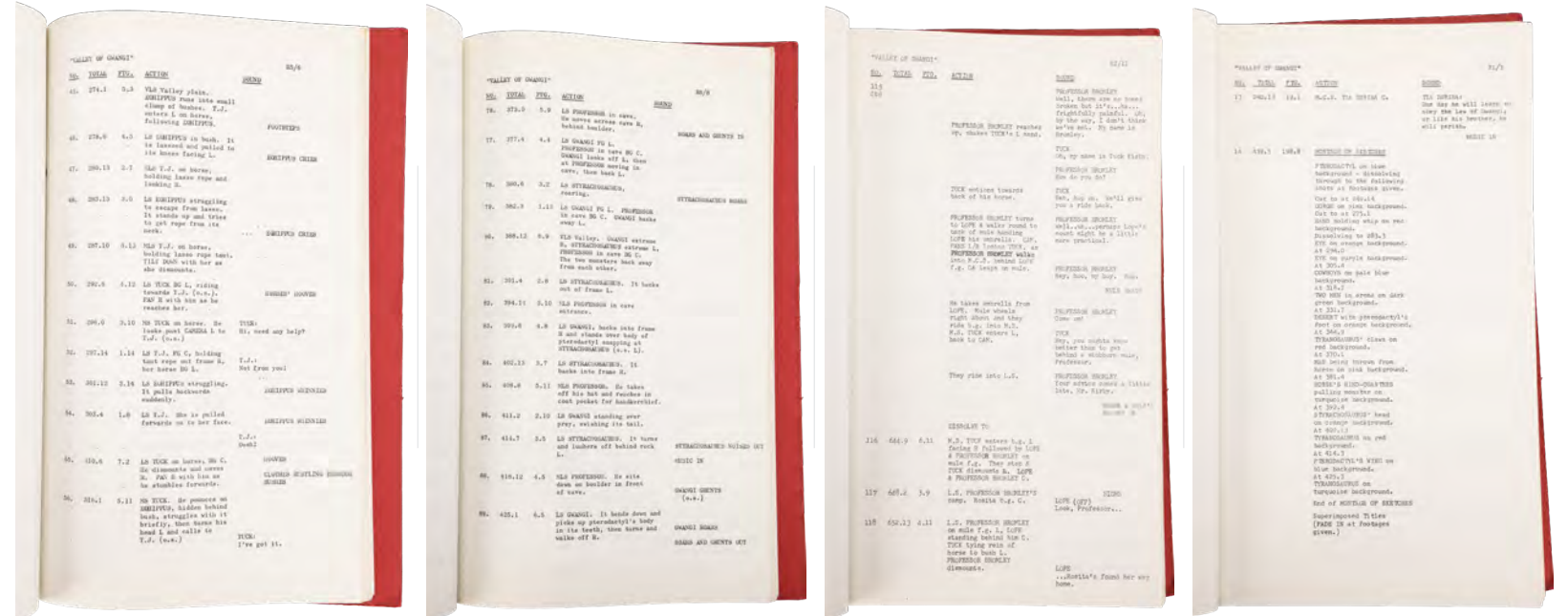

**139**  
Ray Harryhausen Archive:  
Ray Harryhausen's Personal Photo  
Archive Reference Stills m  
**The Valley Of Gwangi (1969)**

Six of Ray Harryhausen's reference stills from the production of Jim O'Connolly's fantasy Western The Valley of Gwangi. This lot comes from Harryhausen's personal collection.

This set comprises three black-and-white behind-the-scenes photographs, two stills of cowboys fighting dinosaurs, and a mock-up for a piece of promotional art. Four of the images feature the film's title in Harryhausen's handwriting, and all but one feature handwritten reference numbers written on the back. Dimensions: 24 cm x 30 cm (9.5" x 11.75")

Sold without copyright; see copyright notice in the Buyer's Guide.

**Estimate: £1,000 - 2,000**





37 cm (14.25")



Scan here to see a full rotation of this lot

**140**

**Ray Harryhausen Archive:  
Kali Lighting Stand-in Model by Ray Harryhausen m  
The Golden Voyage Of Sinbad (1973)**

A Kali lighting stand-in model by Ray Harryhausen from the production of Gordon Hessler's fantasy adventure The Golden Voyage of Sinbad. Koura (Tom Baker) animated a statue of the six-armed Hindu goddess Kali to fight Sinbad (John Phillip Law) and his men. This lot comes from Harryhausen's personal collection.

The audacious and elaborate Kali sequence was animated using Harryhausen's iconic stop-motion techniques. Harryhausen said of the sequence: "I have to confess that when faced with the animation for such a complex sequence, I would wonder why I made life so difficult for myself. It was wonderful to dream and plan such effects, but how would I make them all work? Whatever doubts I had about this sequence, today I am extremely proud of it. Everything seemed to come together. The stunts were all first-rate, and the action flows at a cracking pace."

This resin model was hand-made by Harryhausen and used as a lighting stand-in during the animation process. It is hand-painted to look like ancient worn brass and is accompanied by six swords, also made by Harryhausen during the production, which can be slotted into each hand to create a menacing sight. The model was cast from the same moulds as the animation model seen in the film. Dimensions: 11.5 cm x 32 cm x 37 cm (4.5" x 12.5" x 14.5")

**Estimate: £100,000 - 200,000**

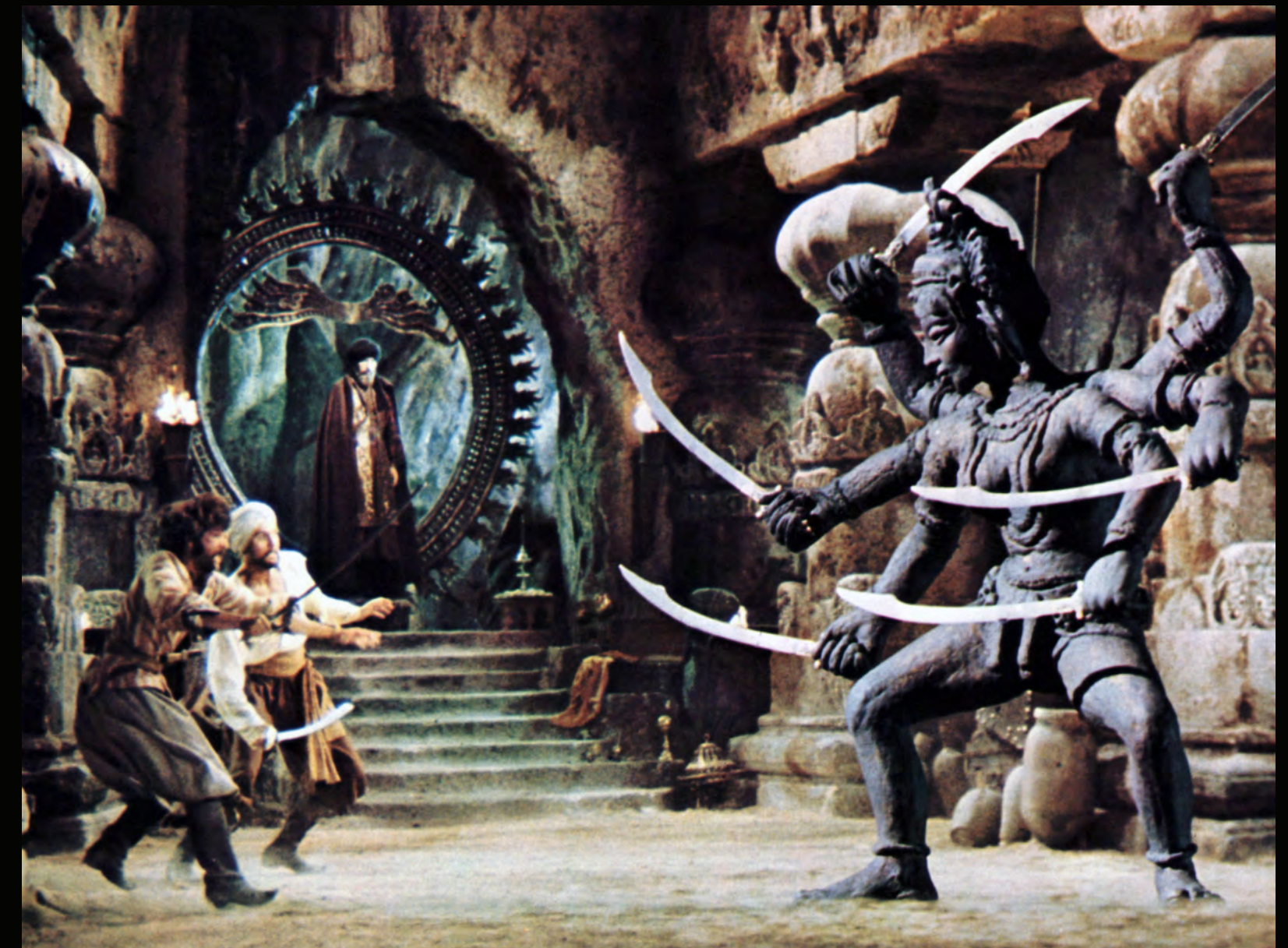

Everett Collection Inc / Alamy Stock Photo





Lifestyle pictures / Alamy Stock Photo



141 Ray Harryhausen Archive: Ray Harryhausen's Personal Signed and Hand-annotated Script m The Golden Voyage Of Sinbad (1973)

Ray Harryhausen's personal signed and hand-annotated script from the production of Gordon Hessler's fantasy adventure The Golden Voyage of Sinbad. The script was written in September 1972 by Brian Clemens, and based upon a story he had co-written with Harryhausen. This lot comes from Harryhausen's personal collection.

This 123-page script is titled "Sinbad's Golden Voyage" (the original title for the film) and credited to Clemens. Harryhausen has signed the first page, and the document is replete with his personal handwritten notes, as well as inserted storyboard pages. The script is bound in green card covers. Dimensions: 28 cm x 22 cm x 2 cm (11" x 8.75" x 0.75")

Estimate: £15,000 - 30,000

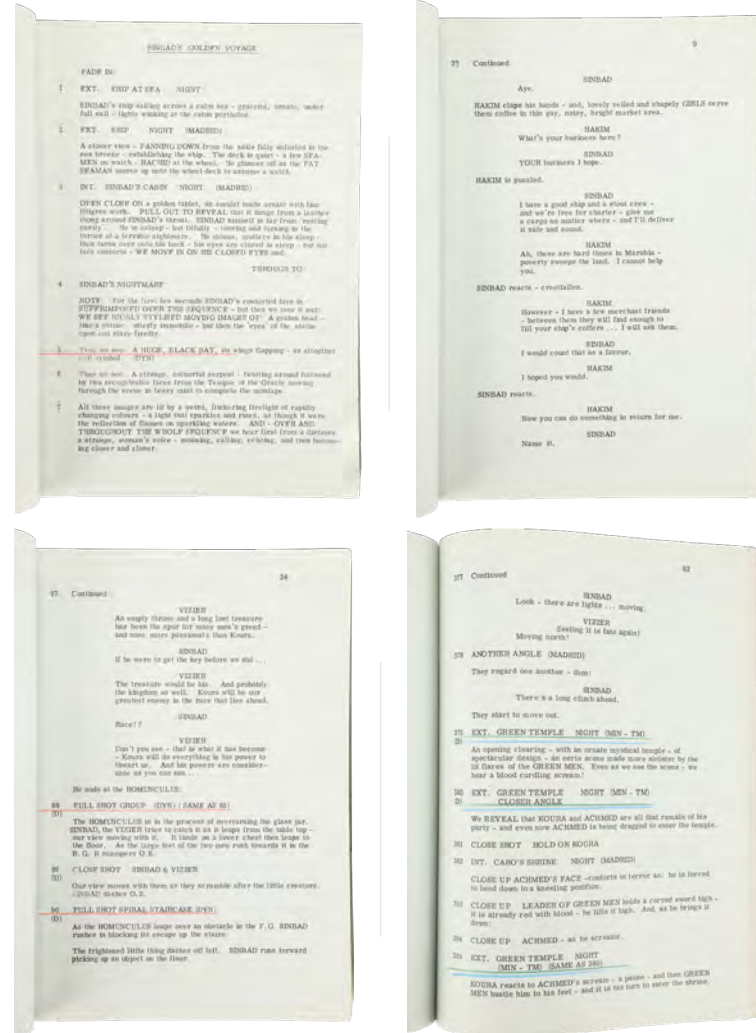
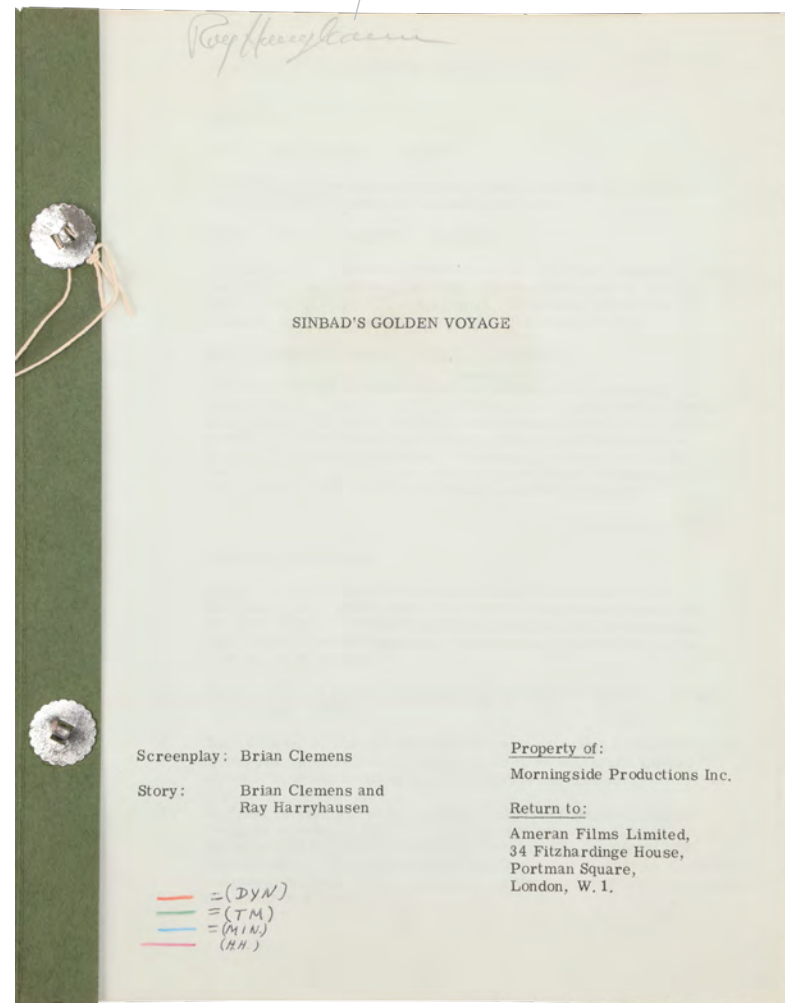
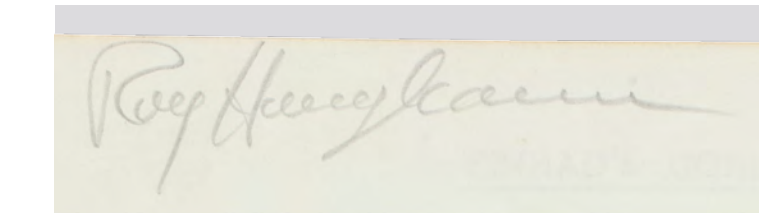

Scan here to see a full rotation of this lot



26 cm (10.5")

142 Ray Harryhausen Archive: Kneeling Ship Siren Figurehead Test Casting by Ray Harryhausen m The Golden Voyage Of Sinbad (1973)

A kneeling ship figurehead test casting by Ray Harryhausen from the production of Gordon Hessler's fantasy adventure The Golden Voyage of Sinbad. The wooden siren figurehead on Sinbad's (John Phillip Law) ship was animated by Koura (Tom Baker) to steal Sinbad's map to the Fountain of Destiny. This lot comes from Harryhausen's personal collection.

Harryhausen created this model in 1972 as a test copy while he worked out the logistics of animating the sequence. It has a hard latex outer layer over a biscuit-foam core, and has been given a protective coating by the Archive to preserve it from light and the atmosphere. It has some minor discolouration and staining, and several of the fingers are missing. Dimensions: 26 cm x 9.5 cm x 21 cm (10.5" x 3.75" x 8.25")

Estimate: £10,000 - 20,000





50 cm (19.75")

**143**  
 Ray Harryhausen Archive:  
 Ray Harryhausen Hand-drawn  
 Sketch of Centaur in Cave m  
**The Golden Voyage Of Sinbad (1973)**

A Ray Harryhausen hand-drawn sketch of a centaur in a cave from the production of Gordon Hessler's fantasy adventure *The Golden Voyage of Sinbad*. This lot comes from the Harryhausen's personal collection.

The sketch depicts the sequence where the centaur confronts Margiana (Caroline Munro). This creature was conceived by Harryhausen while writing the film's screenplay, and he adapted it into a cyclopean centaur to relate it to the cyclops he created for 1958's *The 7th Voyage of Sinbad*.

The drawing is rendered in pencil on tracing paper, with "March 1971" handwritten across the bottom of the page. The paper is torn at the edge but the tear does not disrupt the image. Dimensions: 38 cm x 50 cm (15" x 19.75")

Sold without copyright; see copyright notice in the Buyer's Guide.

**Estimate: £5,000 - 10,000**

**144**  
 Ray Harryhausen Archive:  
 Ray Harryhausen's Personal Photo  
 Archive Reference Stills m  
**The Golden Voyage Of Sinbad (1973)**

Seven of Ray Harryhausen's reference stills from the production of Gordon Hessler's fantasy adventure *The Golden Voyage of Sinbad*. This lot comes from Harryhausen's personal collection.

This set comprises seven black-and-white images. Three feature the one-eyed centaur, two feature the animated Kali statue, one depicts the Kali fight without the Kali statue, and one shows part of the set. Most of the images have the film's title and a reference number handwritten on the back, and two feature Harryhausen's handwritten notes on how the image was produced. Dimensions (largest): 21 cm x 26 cm (8.25" x 10.25")

Sold without copyright; see copyright notice in the Buyer's Guide.

**Estimate: £1,000 - 2,000**



# Propstore

**Sell Your  
 Movie Memorabilia**  
 Achieve world record prices for  
 entertainment memorabilia

**Scream (1996)**  
 Billy Loomis' (Skeet Ulrich) and  
 Stu Macher's (Matthew Lillard)  
 Screen-Matched Ghostface  
 Costume

sold for \$270,900 (£216,720)\*



Reach out for a free appraisal  
 and valuation with our specialists



Email: [consign@propstore.com](mailto:consign@propstore.com)  
 UK Office: +44 (0) 1494 766485  
 US Office: +1 818 727 7829

Scan QR code to visit [propstore.com/props](https://propstore.com/props)



Scan here to see a full rotation of this lot

**145**  
Ray Harryhausen Archive:  
Minaton Lighting Stand-in by Ray  
Harryhausen M  
**Sinbad And The Eye Of The Tiger**  
**(1977)**

A Minaton lighting stand-in made by Ray Harryhausen for the Sam Wanamaker fantasy adventure Sinbad and the Eye of the Tiger. The Minaton was created by Queen Zenobia (Margaret Whiting) to act as her loyal servant and stop Sinbad (Patrick Wayne) from completing his quest. This lot comes from Harryhausen's personal collection.

The film's live-action segments featured British actor Peter Mayhew as Minaton. Mayhew is best known for his multiple appearances as Chewbacca in the Star Wars franchise. The stop-motion effects, meanwhile, were all designed and executed by Harryhausen.

This hard rubber model was originally made during pre-production as a test casting, and then used as a lighting stand-in during filming. This model is cast from the same mould as the one seen in the film. It has been given a protective coating to preserve it from light and the atmosphere. There is some minor wear from production use and age, including some minor cracking, most notably around the fingers. Dimensions: 10 cm x 20 cm x 43 cm (4" x 7.75" x 17")

**Estimate: £50,000 - 100,000**



Courtesy of the Ray Harryhausen Foundation



Everett Collection Inc / Alamy Stock Photo



43 cm (17")



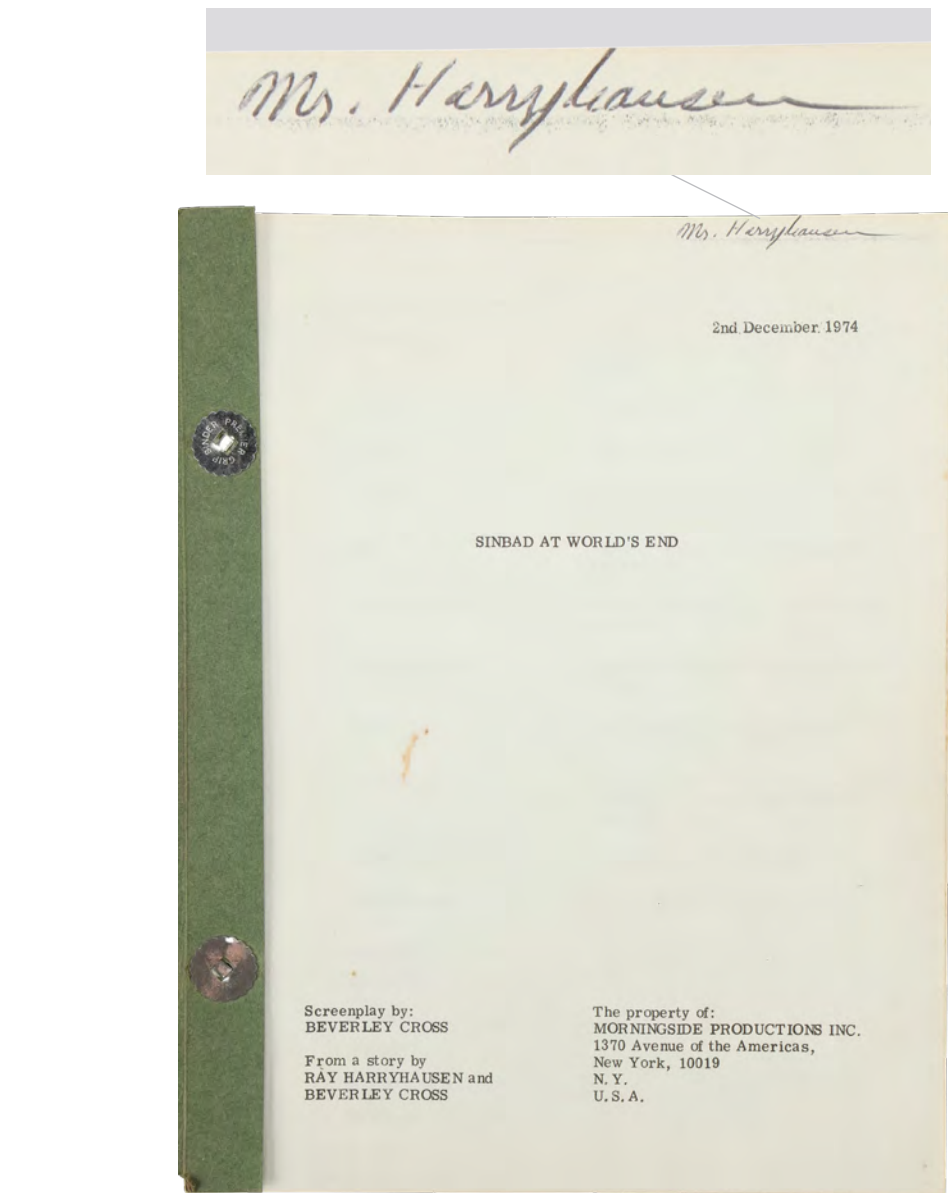

**146**  
 Ray Harryhausen Archive:  
 Ray Harryhausen's Personal Signed  
 and Hand-annotated Script m  
**Sinbad And The Eye Of The Tiger**  
 (1977)

Ray Harryhausen's personal script from the production of Sam Wanamaker's fantasy Sinbad and the Eye of the Tiger. This lot comes from Harryhausen's personal collection.

This 129-page script is titled "Sinbad at World's End", the working title for the film. It is credited to Beverley Cross and Ray Harryhausen, and was written in July 1974, though the script itself is dated "2nd December 1974". Harryhausen has autographed the script, and it is filled with his handwritten notes, as well as containing some photocopied storyboard inserts. The lot has some discolouration along its fore edges. Dimensions: 28 cm x 22 cm x 2 cm (11" x 8.75" x 0.75")

**Estimate: £15,000 - 30,000**

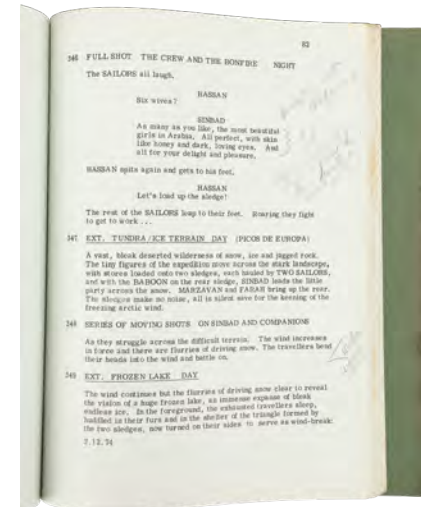
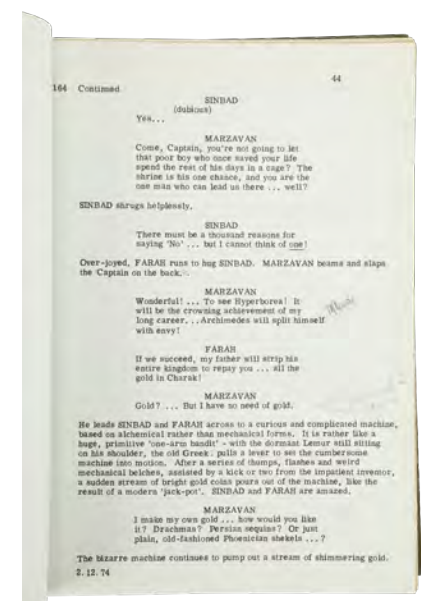

**147**  
 Ray Harryhausen Archive:  
 Early Troglodyte Prototype by  
 Ray Harryhausen m  
**Sinbad And The Eye Of The Tiger**  
 (1977)

An early prototype troglodyte model made by Ray Harryhausen for Sam Wanamaker's fantasy adventure Sinbad and the Eye of the Tiger. This lot comes from Harryhausen's personal collection.

The troglodyte, or "Trog", was a humanoid monster inspired by early renderings of Neanderthal man. Neanderthal fossils discovered in 1829 paved the way for many imaginative renderings of the prehistoric folk, most of which are today considered inaccurate.

This early version of Trog is made of hard latex – a unique feature, as Harryhausen's prototypes were usually clay models – and is dressed in a fur tunic. However, it differs from the final Trog, after Harryhausen decided it "just wasn't imaginative enough". The model comes mounted on a wooden stand, and the tunic shows some minor wear. Dimensions: 42 cm x 22 cm x 17 cm (16.5" x 8.75" x 6.75")

**Estimate: £15,000 - 30,000**



Scan here to see a full rotation of this lot



Everett Collection Inc / Alamy Stock Photo

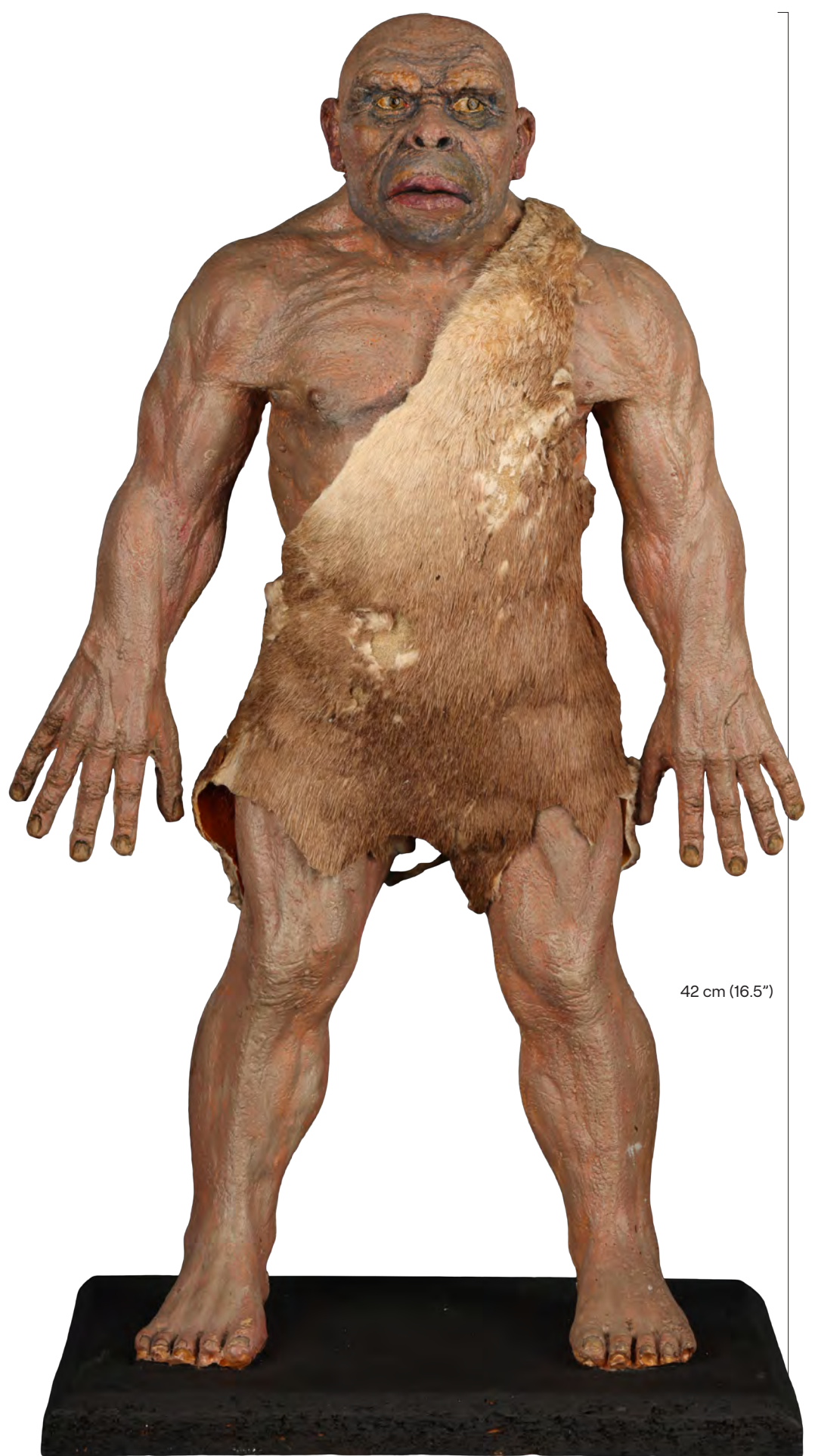

42 cm (16.5")



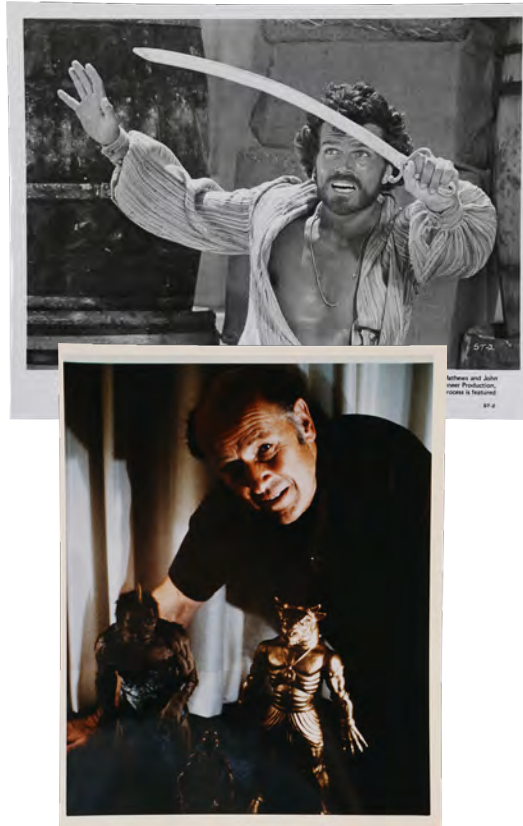

**148**  
 Ray Harryhausen Archive:  
 Ray Harryhausen's Personal Photo  
 Archive Reference Stills M  
**Sinbad And The Eye Of The Tiger**  
 (1977)

Six of Ray Harryhausen's reference stills from the production of Sam Wanamaker's fantasy adventure Sinbad and the Eye of the Tiger. This lot comes from Harryhausen's personal collection.

This set comprises five black-and-white images and one colour image. The colour still shows Harryhausen with three of his models. Two of the black-and-white images feature Harryhausen behind the scenes, while two are promotional images, and one depicts the fight between the sabre-toothed tiger and the troglodyte. Two of the images have a reference number handwritten on the back and one has a stamp from Columbia Pictures. Dimensions (largest): 20.5 cm x 25.5 cm (8" x 10")

Sold without copyright; see copyright notice in the Buyer's Guide.

**Estimate: £1,000 - 2,000**

**149**  
 Ray Harryhausen Archive:  
 Ray Harryhausen's Personal Photo  
 Archive Reference Stills M  
**Clash Of The Titans (1981)**

Five of Ray Harryhausen's reference stills from the production of Desmond Davis' epic fantasy adventure Clash of the Titans. This lot comes from Harryhausen's personal collection.

This set comprises five black-and-white behind-the-scenes photographs: three of the Medusa model, one of the head of the statue of Thetis (Maggie Smith), and one of Tim Pigott-Smith in costume as Thallo. All the images have Harryhausen's handwritten notes or reference numbers on the reverse. Dimensions (largest): 20.5 cm x 25.5 cm (8" x 10")

Sold without copyright; see copyright notice in the Buyer's Guide.

**Estimate: £1,000 - 2,000**

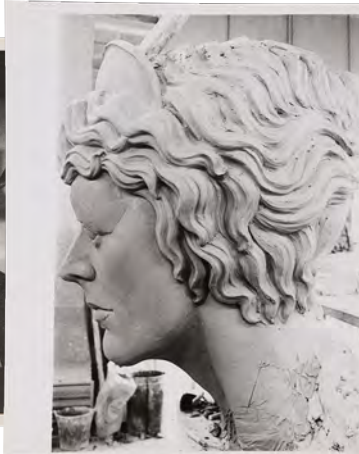

21 cm (8.25")

**150**  
 Ray Harryhausen Archive: Medusa Early Wax Sculpt by Ray Harryhausen M  
**Clash Of The Titans (1981)**

An early wax sculpt of Medusa by Ray Harryhausen from the production of Desmond Davis' epic fantasy adventure Clash of the Titans. The Gorgon Medusa could turn any living being into stone with her gaze, and Perseus (Harry Hamlin) needed her head to defeat the Kraken. This lot comes from Harryhausen's personal collection.

This hollow purple wax head was personally designed and sculpted by Harryhausen during pre-production on the film in 1978, as a template for the final stop-motion model.

The head has some minor wear from age and use, most notably some discolouration and staining on the top and the back.

Dimensions: 21 cm x 17.5 cm x 12 cm (8.25" x 7" x 4.75")

**Estimate: £30,000 - 60,000**



Scan here to see a full rotation of this lot



25 cm (9.75")

**151**  
 Ray Harryhausen Archive:  
 Full-size Medusa Head Prototype m  
**Clash Of The Titans (1981)**

A full-size Medusa head prototype from the production of Desmond Davis' epic fantasy adventure Clash of the Titans. The Gorgon Medusa could turn any living being into stone with her gaze, and Perseus (Harry Hamlin) needed her head to defeat the Kraken. This lot comes from Harryhausen's personal collection.

This fibreglass head was a prototype for the one Perseus carried after decapitating Medusa. It was designed by Ray Harryhausen to match his stop-motion-animated model of Medusa, and the final piece used in the film was made by Colin Arthur, based on Harryhausen's design.

The head is hand-painted, including a pair of vivid blue eyes. There is some wear from age and use, including paint wear, minor chips, paint transfer and adhesive remnants. Dimensions: 25 cm x 15 cm x 23 cm (9.75" x 6" x 9")

**Estimate: £15,000 - 30,000**



Scan here to see a full rotation of this lot



Collection Christophel / Alamy Stock Photo



LANDMARK MEDIA / Alamy Stock Photo



33 cm (13")

**152**  
 Ray Harryhausen Archive:  
 Dioskilos Test Casting by Ray Harryhausen m  
**Clash Of The Titans (1981)**

A Dioskilos test casting by Ray Harryhausen from the production of Desmond Davis' epic fantasy adventure Clash of the Titans. Dioskilos, a two-headed dog, was Medusa's guardian, and it attacked Perseus (Harry Hamlin) and his men, before Perseus stabbed the beast in both necks and then its stomach, finishing it off. This lot comes from Harryhausen's personal collection.

Made by Harryhausen in 1978, this hollow, hard rubber test casting came from the original Dioskilos mould, making it identical to the sculpt for the final animation model. It has been given a protective coating by the Archive to preserve it from light and the atmosphere. This model has some wear from age and use, including discolouration and staining. Dimensions: 33 cm x 8.5 cm x 20 cm (13" x 3.25" x 7.75")

**Estimate: £7,500 - 15,000**



Scan here to see a full rotation of this lot



LANDMARK MEDIA / Alamy Stock Photo

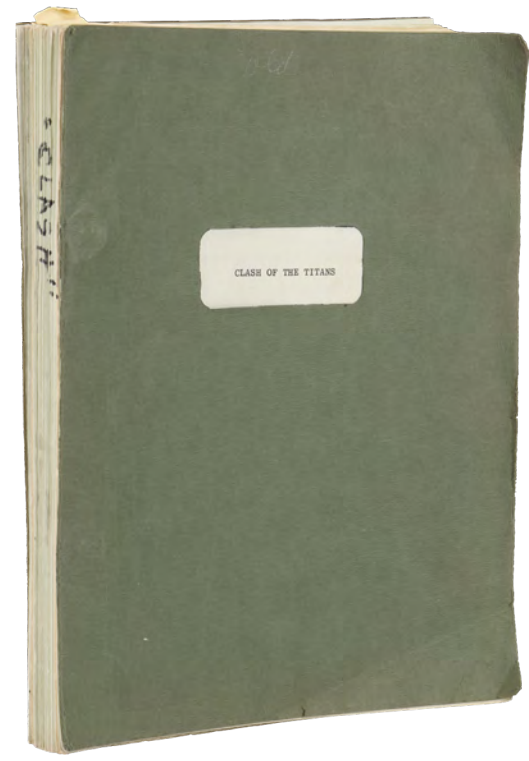

**153**  
 Ray Harryhausen Archive:  
 Ray Harryhausen's Personal Hand-annotated Script m  
**Clash Of The Titans (1981)**

Ray Harryhausen's personal hand-annotated script from the production of Desmond Davis' epic fantasy adventure Clash of the Titans. This lot comes from Harryhausen's personal collection.

The script is 127 pages long and titled "Clash of the Titans". It is credited to Beverley Cross, who had previously written Jason and the Argonauts. Cross' wife Maggie Smith appeared in the film as Thetis. This is the final screenplay as filmed, and has "Old Script" and the numbers "603-3333 RM 358" written on the front cover, with "Clash" written on the spine. The script features Harryhausen's hand-annotated notes throughout.

The script also contains photocopies of Harryhausen's artwork and storyboards. It exhibits minor discoloration on the fore edges, and some slight dog-earing. Dimensions: 28 cm x 22 cm x 2 cm (11" x 8.75" x 0.75")

**Estimate: £15,000 - 30,000**



49.5 cm (19.5")

**154**  
 Ray Harryhausen Archive:  
 Ray Harryhausen Hand-drawn Sketch of Medusa with Perseus and Soldier m  
**Clash Of The Titans (1981)**

A Ray Harryhausen hand-drawn sketch of Medusa with Perseus and a soldier from the production of Desmond Davis' epic fantasy adventure Clash of the Titans. This lot comes from Harryhausen's personal collection.

The sketch depicts Medusa armed with a bow, looking at a soldier, and Perseus using his shield as a mirror to see her. Due to an increased level of production responsibilities, this was one of only two key drawings produced by Harryhausen for the film.

The sketch is rendered in pencil on tracing paper, with ink used in certain places to embolden individual lines. It exhibits some minor tearing, but otherwise remains in very good condition. Dimensions: 49.5 cm x 36 cm (19.5" x 14.25")

Sold without copyright; see copyright notice in the Buyer's Guide.

**Estimate: £10,000 - 20,000**



**155**  
 Ray Harryhausen Archive:  
 Ray Harryhausen Hand-drawn  
 Sketch of the Kraken and  
 Andromeda M  
**Clash Of The Titans (1981)**

A Ray Harryhausen hand-drawn sketch of the Kraken and Andromeda (Judi Bowker) from the production of Desmond Davis' epic fantasy adventure Clash of the Titans. This lot comes from Harryhausen's personal collection.

The sketch depicts the Kraken looming over Princess Andromeda. The sketch was initially drawn by Harryhausen, though unusually the final piece of concept art was completed by artist Cathy Hill under Harryhausen's supervision. In the margins of the image Harryhausen has drawn small, rough sketches, and written "John Martin". Martin's vast, epic paintings were a source of inspiration for Harryhausen throughout his career. Dimensions: 48 cm x 59 cm (19" x 23.25")

Sold without copyright; see copyright notice in the Buyer's Guide.

**Estimate: £10,000 - 20,000**



**156**  
 Ray Harryhausen Archive:  
 Ray Harryhausen Hand-drawn  
 Sketch of Perseus and the Stygian  
 Witches M  
**Clash Of The Titans (1981)**

A Ray Harryhausen hand-drawn sketch of Perseus and the Stygian witches from the production of Desmond Davis' epic fantasy adventure Clash of the Titans. This lot comes from Harryhausen's personal collection.

The sketch depicts Perseus and a soldier meeting with the Stygian witches. Due to an increased level of production responsibilities, this was one of only two key drawings created by Harryhausen for the film. The sketch is rendered in pencil on tracing paper, and exhibits some minor tears, none which disrupt the image. It has undergone sympathetic restoration to mend a larger tear. Dimensions: 52 cm x 38 cm (20.5" x 15")

Sold without copyright; see copyright notice in the Buyer's Guide.

**Estimate: £5,000 - 10,000**



Raven Armoury detail underneath each statuette

**157**  
 Ray Harryhausen Archive: Ray Harryhausen's Personal Set of Silvered  
 Bronze Skeletons by Raven Armoury M  
**Ray Harryhausen**

Ray Harryhausen's personal set of silvered bronze skeletons, gifted to him by the Raven Armoury. This lot comes from Harryhausen's personal collection.

The set comprises eight skeleton statuettes, each made of silvered bronze, and a booklet that elaborates on the filmic history of the "living skeleton". Each skeleton is posed differently, including one posed to look as it is emerging from the ground, and all are armed.

This was Harryhausen's personal set, hand-made by the Raven Armoury and gifted to Harryhausen in 2013 to commemorate the 50th anniversary of Jason and the Argonauts, in which Jason (Todd Armstrong) fought the "Children of the Hydra", a troop of living skeletons. With Harryhausen's endorsement, the Raven Armoury produced a limited number of sets - only 250 individual skeletons were ever made - which were commercially available. Inside the booklet is a certificate of authenticity, and the statues come in their original Raven Armoury boxes, all of which remain in excellent condition. Dimensions: 72 cm x 15 cm x 44 cm (28.5" x 6" x 17.5")

**Estimate: £5,000 - 10,000**

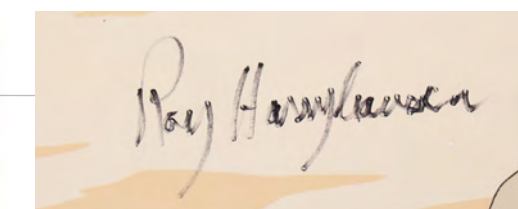

**158**  
 Ray Harryhausen Archive:  
 "Special Effects Titan" Quad Poster  
 Autographed by Ray Harryhausen M  
**Ray Harryhausen**

A "Special Effects Titan" quad poster autographed by Ray Harryhausen. This lot comes from Harryhausen's personal collection.

The poster is for the 2011 documentary 'Ray Harryhausen: Special Effects Titan,' which featured contributions from Peter Jackson, Steven Spielberg, James Cameron, Nick Park, John Landis, Phil Tippett, Tim Burton, Guillermo Del Toro and many more actors, directors and special effects artists. It has been autographed by Harryhausen in black ink, and marked "4/15". Dimensions: 35.5 cm x 50 cm (14" x 19.75")

**Estimate: £500 - 1,000**

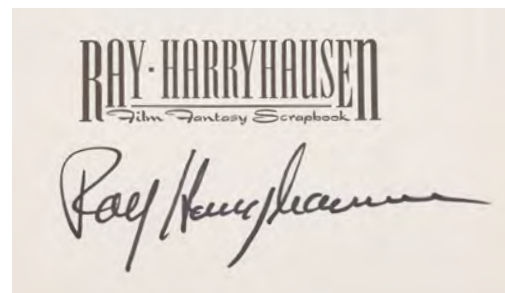
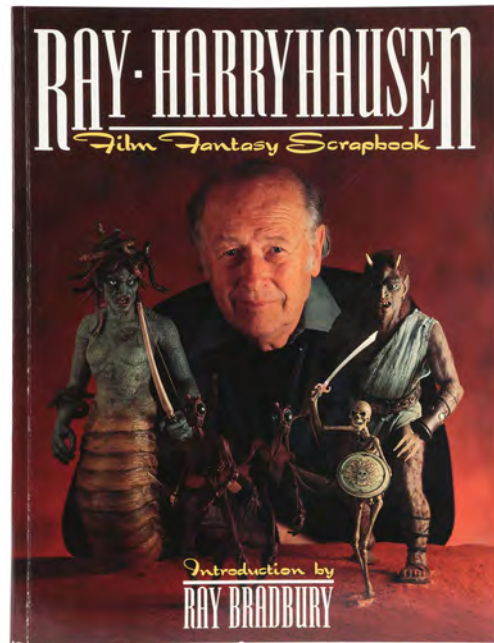

**159**  
Ray Harryhausen Archive:  
"Film Fantasy Scrapbook"  
Autographed by Ray Harryhausen m  
**Ray Harryhausen**

A copy of "Film Fantasy Scrapbook" autographed by Ray Harryhausen. This third edition re-release of Harryhausen's book detailing his remarkable career has been autographed in black ink on the title page by Harryhausen himself. This lot comes from Harryhausen's personal collection. Dimensions: 28 cm x 21.5 cm x 1 cm (11" x 8.5" x 0.5")

**Estimate: £500 - 1,000**

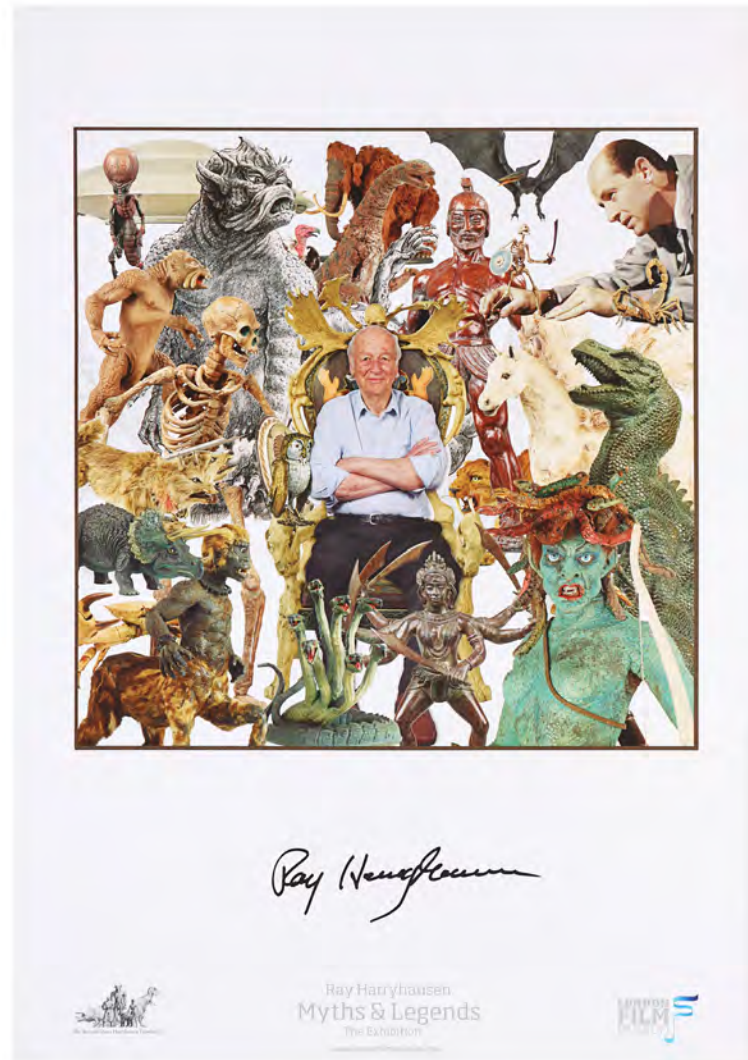

**160**  
Ray Harryhausen Archive:  
London Film Museum Exhibition Poster m  
**Ray Harryhausen**

A London film museum exhibition poster from the collection of Ray Harryhausen. This lot comes from the personal collection of Ray Harryhausen.

This is Harryhausen's personal copy of the poster from the 2010 exhibition 'Ray Harryhausen: Myths and Legends,' featuring a collage of photography taken by Andy Johnson. Run to coincide with Ray's 90th birthday celebrations and his special lifetime achievement BAFTA award, this was the final major display of Harryhausen's work to take place during his lifetime. Dimensions: 84 cm x 60 cm (33" x 23.75")

**Estimate: £500 - 1,000**



**161**  
Argonaut SFX Retractable Sword, Argonaut Hero Metal Sword with  
Scabbard and 'Polydeuces' (John Crawford) Shield n  
**Jason And The Argonauts (1963)**

An Argonaut SFX retractable sword, an Argonaut hero metal sword, and Polydeuces' (John Crawford) shield from Don Chaffey's fantasy adventure film Jason and the Argonauts. Swords and shields were carried by the Argonauts throughout the film, and shields were also used to decorate the sides of the Argo, their ship. This particular shield belonged to the Argonaut Polydeuces.

Both the swords and their scabbards are made of metal, and decorated with circular details. The retractable sword's scabbard is painted black, while the scabbard of the hero sword is a bronze colour. The shield is also made of metal, and painted with the image of a harpy. It has canvas straps on the reverse side, which are fraying. The shield exhibits some paint wear, and both the shield and swords exhibit rusting, owing to their age. Otherwise, all three remain in good condition. Dimensions: 78 cm x 64 cm x 11 cm (30.75" x 25.25" x 4.25")

Edged, bladed or blunt object; see notice on Blades in the Buyer's Guide.

**Estimate: £12,500 - 25,000**



**162**  
Argonaut SFX Retractable Sword,  
Argonaut Hero Metal Sword with  
Scabbard and 'Owl' Shield Ω  
**Jason And The Argonauts (1963)**

An Argonaut SFX retractable sword, an Argonaut hero metal sword, and an owl shield from Don Chaffey's fantasy adventure film Jason and the Argonauts. Swords and shields were carried by the Argonauts throughout the film, and shields were also used to decorate the sides of the Argo, their ship.

Both the swords and their scabbards are made of metal, and decorated with circular details. The retractable sword's scabbard is painted black, while the scabbard of the hero sword is a bronze colour. The shield is also made of metal, and painted with the image of an owl. It has canvas straps on the reverse side, which are fraying. The shield exhibits some paint wear, and both the shield and swords exhibit rusting, owing to their age. Otherwise, all three remain in good condition. Dimensions: 78 cm x 64 cm x 11 cm (30.75" x 25.25" x 4.25")

Edged, bladed or blunt object; see notice on Blades in the Buyer's Guide.

**Estimate: £10,000 - 20,000**



**163**  
Argonaut SFX Retractable Sword,  
Argonaut Hero Metal Sword with  
Scabbard and 'Centaur' Shield Ω  
**Jason And The Argonauts (1963)**

An Argonaut SFX retractable sword, an Argonaut hero metal sword, and a centaur shield from Don Chaffey's fantasy adventure film Jason and the Argonauts. Swords and shields were carried by the Argonauts throughout the film, and shields were also used to decorate the sides of the Argo, their ship.

Both the swords and their scabbards are made of metal, and decorated with circular details. The retractable sword's scabbard is painted black, while the scabbard of the hero sword is a bronze colour. The shield is also made of metal, and painted with the image of a centaur drawing a bow. It has canvas straps on the reverse side, which are fraying. The shield exhibits some paint wear, and both the shield and swords exhibit rusting, owing to their age. Otherwise, all three remain in good condition. Dimensions: 78 cm x 64 cm x 11 cm (30.75" x 25.25" x 4.25")

Edged, bladed or blunt object; see notice on Blades in the Buyer's Guide.

**Estimate: £7,500 - 15,000**



ScreenProd / Photononstop / Alamy Stock Photo



**164**  
The Costumi d'Arte Collection: Jason's  
(Todd Armstrong) Screen-matched Cuirass Ω  
**Jason And The Argonauts (1963)**

Jason's (Todd Armstrong) screen-matched cuirass from Don Chaffey's fantasy adventure film Jason and the Argonauts. Jason wore his cuirass when he slayed the Hydra, and also when he fought the skeletal "Children of the Hydra's Teeth" after using the Golden Fleece to resurrect Medea (Nancy Kovack). This lot comes from the archives of the Italian costume company Costumi d'Arte.

Creases in the gold leather detailing match the cuirass as the one seen on screen when Jason arrived in Colchis and later when he acquired the Golden Fleece after defeating the Hydra.

The cuirass is made of black leather, with metal golden details and additional floral details in gold leather. There are metal floral and stud details on the fringing, and the cuirass laces up at either side. The cuirass also features a ring on either shoulder, onto which a cape was attached for some scenes. The leather exhibits some minor cracking and discolouration.

**Estimate: £7,500 - 15,000**



**165**  
The Costumi d'Arte Collection: Phalerus'  
(Andrew Faulds) Cuirass Ω  
**Jason And The Argonauts (1963)**

Phalerus' (Andrew Faulds) cuirass from Don Chaffey's fantasy adventure Jason and the Argonauts. Phalerus wore his cuirass while fighting the skeleton warriors alongside Jason (Todd Armstrong), before he was killed during this iconic battle. This lot comes from the archives of the Italian costume company Costumi d'Arte.

The cuirass is made of black leather and comes in two parts, which attach together at the shoulders and waist. Both the breastplate and backplate are decorated with square metal details, and the breastplate has additional metal floral detailing. The cuirass also features black leather fringing studded with metal details along its bottom edge, and the number "3" is handwritten on the interior of the backplate. There is some slight cracking around the edges of the cuirass.

**Estimate: £5,000 - 10,000**



**166**  
The Costumi d'Arte Collection:  
Castor's (Ferdinando Poggi) Cuirass  $\Omega$   
**Jason And The Argonauts (1963)**

Castor's (Ferdinando Poggi) costume from Don Chaffey's fantasy film Jason and the Argonauts. This lot comes from the archives of the Italian costume company Costumi d'Arte.

Castor wore his cuirass while fighting the children of the Hydra's teeth alongside Jason (Todd Armstrong), during which he was killed. The cuirass is made of grey and black leather and is in two parts, which attach together at the shoulders and waist. Attached to the bottom of the cuirass is black leather fringing studded with square metal details. The chest and back of the cuirass are also decorated with square metal details, and the breastplate with cut-out detailing in the leather. Atop the shoulders are two metal hooks, onto which a cape could be attached. An additional two hooks are fixed to the centre of the waistband, though the purpose of these is unclear. There is some slight cracking in the leather around the edges of the cuirass.

**Estimate: £5,000 - 10,000**



**167**  
The Costumi d'Arte Collection:  
King Pelias' (Douglas Wilmer) Cuirass  $\Omega$   
**Jason And The Argonauts (1963)**

King Pelias' (Douglas Wilmer) cuirass from Don Chaffey's fantasy adventure Jason and the Argonauts. Pelias wore his cuirass while usurping the throne of Thessaly. This lot comes from the archives of the Italian costume company Costumi d'Arte.

The cuirass is made of dark brown leather, with gold metal spiral detailing across the breastplate and brown leather fringing with metal stud details. A golden chain sits around the neckline, and two large hoops on either shoulder facilitated the attachment of a cape. The backplate and breastplate fasten together via buckles at the waist. The leather exhibits minor cracking and discolouration.

**Estimate: £5,000 - 10,000**



**168**  
Jason and the Argonauts and The Golden Voyage of Sinbad VHS Concept Artworks with VHS Tapes  $\Omega$   
**Ray Harryhausen**

Concept artworks for the VHS covers of the Ray Harryhausen films Jason and the Argonauts and The Golden Voyage of Sinbad, with their corresponding VHS tapes. Included in this lot are four pieces of original artwork, two for each film, and two VHS tapes, each in their original boxes. The artworks are concepts for VHS covers, drawn in pencil on tracing paper and mounted onto cardstock. Each piece was drawn by Corey Wolfe, who has appended his signature to all of them and is responsible for the cover artwork for numerous popular films, including Brother Bear II and Lilo and Stitch II. The artworks include the concepts marked as "approved," which can be seen printed in full colour on the VHS tape boxes, though there are minor differences between the approved tracings and final covers. Dimensions: 34 cm x 26 cm x 7 cm (13.5" x 10.25" x 2.75").

Sold without copyright; please see notice in the Buyer's Guide.

**Estimate: £2,500 - 5,000**



**169**  
Pete "English Pete" Hicox's (Tim Roth) "Oswaldo Mobray" Costume  $\Omega$   
**The Hateful Eight (2015)**

Pete "English Pete" Hicox's (Tim Roth) "Oswaldo Mobray" costume from Quentin Tarantino's The Hateful Eight. English Pete wore his costume while masquerading as hangman Oswaldo Mobray in Minnie's Haberdashery.

The Hateful Eight was extensively critically acclaimed, earning three Academy Award® nominations. Its ensemble cast was particularly well-praised, with Roth earning notice from such awards bodies as the Critics Choice Awards and the International Cinephile Society.

This costume consists of a black silk-lined felt bowler hat with a matching band and a matching leather strap with a gold-colour stripe on the interior; a grey woolen overcoat with tortoiseshell-patterned buttons, synthetic fur lining the collar and lapel, and rust-colour satin blend interior lining; a metallic grey silk necktie; a grey plaid woolen jacket with speckled chest and cuff buttons; a matching vest with black cotton backing; matching trousers with a brass waist buckle; a white cotton John Varvatos dress shirt (Size L) with pearlescent buttons and embroidered diamond patterns; black leather Gaspar gloves (Size 6); metallic grey elasticated Wahmaker suspenders with black leather detailing; a black leather R.S. Giles belt with red thread detailing hand-labelled "Oswaldo Hero Double" on the underside; and a pair of dark brown leather Ariat boots (U.K. Size 9W) hand-labelled "Oswaldo Inside."

Also included is a production wardrobe tag labelled "Oswaldo Mobray (English Pete)" and "Hero #1," as well as a colour-printed behind-the-scenes still of Roth in costume on the Haberdashery set. The costume is intentionally distressed by production with faded colours, cracked leather, and minor grime applied to appear well-worn and exposed to elements.

**Estimate: £6,000 - 12,000**



**170**  
Chris Mannix's (Walton Goggins) Screen-matched Bloodied Sheriff's Costume  $\Omega$   
**The Hateful Eight (2015)**

Chris Mannix's (Walton Goggins) screen-matched bloodied sheriff's costume from Quentin Tarantino's The Hateful Eight. Intentional distressing on this costume screen-matches to the bloody aftermath of the sheriff's shootout with English Pete, aka Oswaldo Mobray (Tim Roth), at Minnie's Haberdashery.

The Hateful Eight was extensively critically acclaimed, earning three Academy Award® nominations. Its ensemble cast was particularly well-praised, with Goggins earning notice from such awards bodies as the Academy of Science Fiction, Fantasy & Horror Films and the International Cinephile Society.

This costume consists of a grey woolen confederate-style overcoat with brass Waterbury Button buttons engraved "CSA" (Confederate States of America); a black felt and wool vest with leather piping and grey striping on its reverse; a black and grey plaid woolen necktie; a white cotton blend long-sleeve dress shirt with navy striping and a band collar; and grey woolen trousers with black and gold-colour striping. Also included are wardrobe tags labelled "Chris Mannix - Change 1" and "Mannix Sc. 39 Shootout Aftermath."

The costume exhibits extensive blood-staining with a bullet hole on the left side of the coat, tearing on the tie and trousers, and grime applied throughout. It exhibits some pilling, fraying, and curled edges from production wear.

**Estimate: £6,000 - 12,000**



**171**  
 "Grouch" Douglass's (Michael Madsen) "Joe Gage" Costume Ω  
**The Hateful Eight (2015)**

"Grouch" Douglass's (Michael Madsen) "Joe Gage" costume from Quentin Tarantino's *The Hateful Eight*. Douglass wore his costume while masquerading as cowboy Joe Gage on his way to, and in, Minnie's Haberdashery.

*The Hateful Eight* was extensively critically acclaimed, earning three Academy Award® nominations. Its ensemble cast was particularly well-praised, with Madsen earning notice from such awards bodies as the Critics Choice Awards and the International Cinephile Society.

This costume consists of a black beaver felt Stetson cowboy hat (Size 7 5/8) with brown leather inner lining, a braided and fringed black leather adjuster, serial number "RF956358," and an interior label hand-marked "Joe Gage Hero #1"; a rust-colour cotton bandana; a black leather single-breasted vest with black cotton lining; a blue cotton Ralph Lauren long-sleeve shirt with orange horseshoe patterns and a pearlescent snap-button closure; a sheer red cotton blend J. Crew long-sleeve henley (Size XL) with metal buttons; a pair of brown leather lace-up gauntlets with brass eyelets; black leather Gaspar gloves (Size 10); a flower-patterned brown leather belt with a brass buckle hand-marked "40"; black Levi's bootcut jeans (Size 38x36); and tan leather Nocona boots (U.S. Size 11) with decorative leaf-patterned stitching, snow spikes affixed under the soles, and "Joe Gage Spikes Snow" hand-marked on their interiors.

Also included is a production wardrobe tag labelled "Joe Gage (Grouch Douglass)" and "Clean #4," as well as a colour-printed behind-the-scenes still of Madsen in costume on the Haberdashery set. The costume is intentionally distressed by production with faded colours, cracked leather, and minor grime applied to appear well-worn and exposed to elements.

**Estimate: £6,000 - 12,000**



**172**  
 Marco's (Demian Bichir) "Bob the Mexican" Costume Ω  
**The Hateful Eight (2015)**

Marco's (Demian Bichir) "Bob the Mexican" costume from Quentin Tarantino's *The Hateful Eight*. Major Marquis Warren (Samuel L. Jackson) shot Marco upon discovering that he was masquerading as Bob the Mexican, the caretaker of Minnie's Haberdashery.

*The Hateful Eight* was extensively critically acclaimed, earning three Academy Award® nominations. Its ensemble cast was particularly well-praised, with Bichir earning notice from such awards bodies as the Critics Choice Awards and the International Cinephile Society.

This costume consists of a grey rabbit felt cowboy-style hat with a brown leather band on the exterior and a darker brown leather band on the interior numbered "3" and hand-marked "S" and "Brown Road" in ink; a brown and grey cable knit woollen scarf; a custom hooded overcoat known by production as the "coat of many cats," made from various synthetic furs, and lined on the interior with fabric patches for sealing squib holes; a handwoven and colourfully-patterned green woollen Ortega's vest (Size 42) with metallic grey trim and wood buttons; a brown woollen collared henley; an off-white cotton and polyester Ralph Lauren henley undershirt (Size L); black leather Gaspar gloves, one of which is hand-marked "CHX" on the interior; a blue and grey striped cotton apron; a brown leather belt (Size 34) stamped with Southwestern patterns; brown leather gaiters hand-marked "L" and "R," respectively, with teardrop patterns and metal buckles and rivet; brown and grey striped cotton Ralph Lauren trousers (Size 36x32); and a pair of brown leather Lucchese boots (U.S. size 11 1/2) stamped with matching eight-digit inventory numbers on their interiors.

Also included is a production wardrobe tag labelled "Bob the Mexican (Marco) Change 1" and "Clean 4," as well as a colour-printed behind-the-scenes still of Bichir in costume.

The costume is intentionally distressed by production with faded colours, cracked leather, various tears, staining, and grime applied to appear well-worn and exposed to elements.

**Estimate: £6,000 - 12,000**

**173**  
 Harry Potter's (Daniel Radcliffe) Hero Wooden Wand Ω  
**Harry Potter And The Philosopher's Stone (2001)/Harry Potter And The Chamber Of Secrets (2002)**

Harry Potter's (Daniel Radcliffe) hero wooden wand from Chris Columbus' *Harry Potter and The Philosopher's Stone*. This style of Harry's wand was seen in the first two films of the series, *The Philosopher's Stone* and *The Chamber of Secrets*.

Harry's iconic wand is his quintessential accessory throughout the film series, choosing it at Ollivander's wand shop and using it in lessons and later conflicts, including in his battle with the basilisk and to knock out Severus Snape (Alan Rickman). The wand is made of wood, stained a dark brown, and features a slight curve in the handle and two carved ridges separating the handle from the shaft. After *The Chamber of Secrets*, the style of Harry's wand changed. Dimensions: 41 cm x 9 cm x 4 cm (16.25" x 3.5" x 1.5")

**Estimate: £20,000 - 40,000**

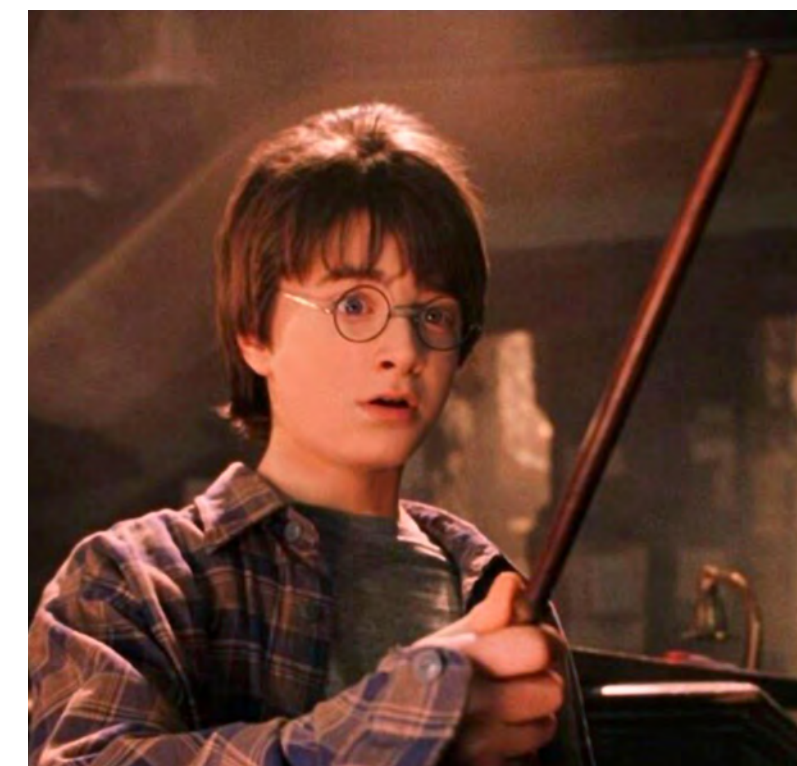
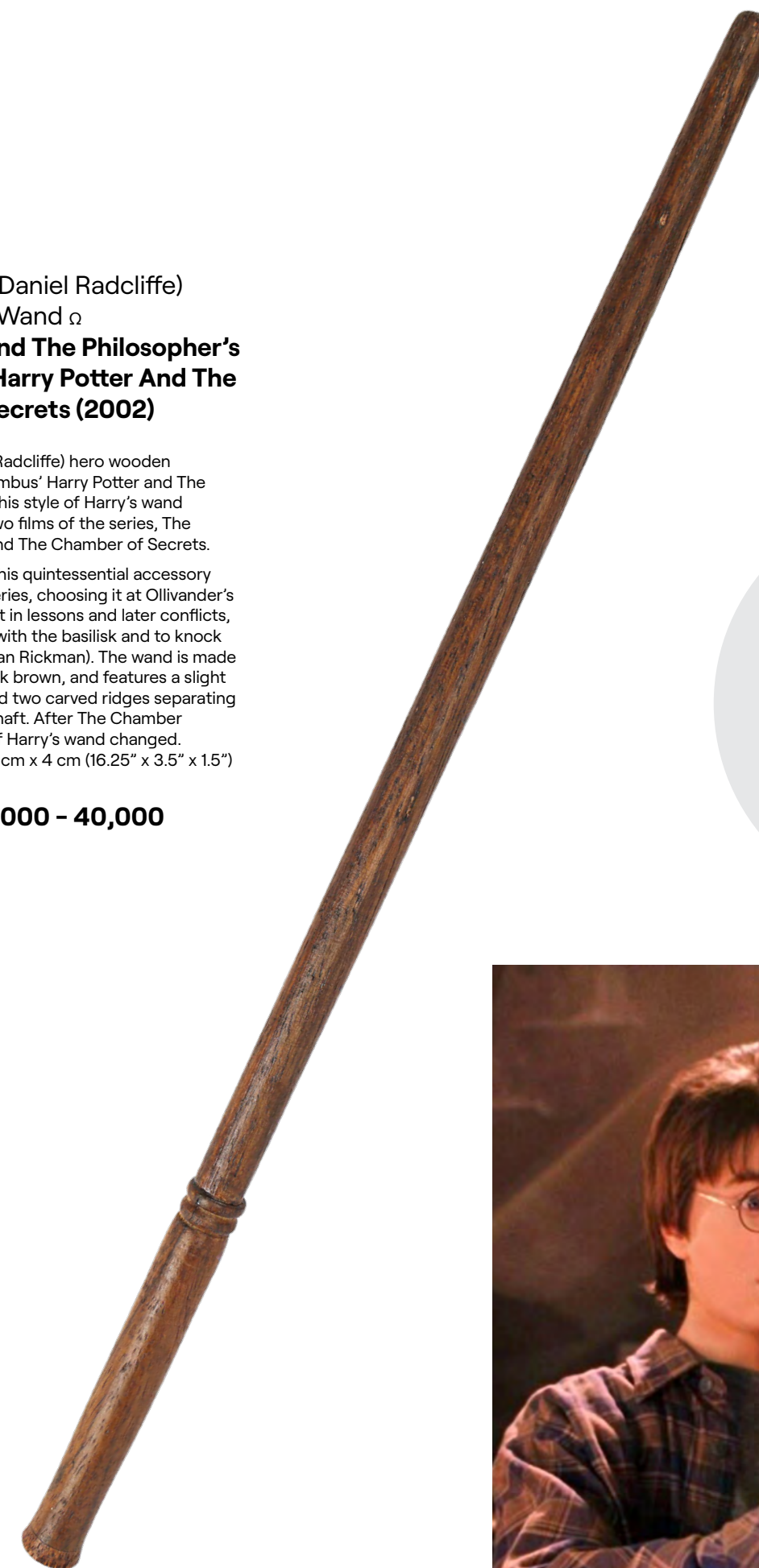

Collection: Christopher / Alamy Stock Photo



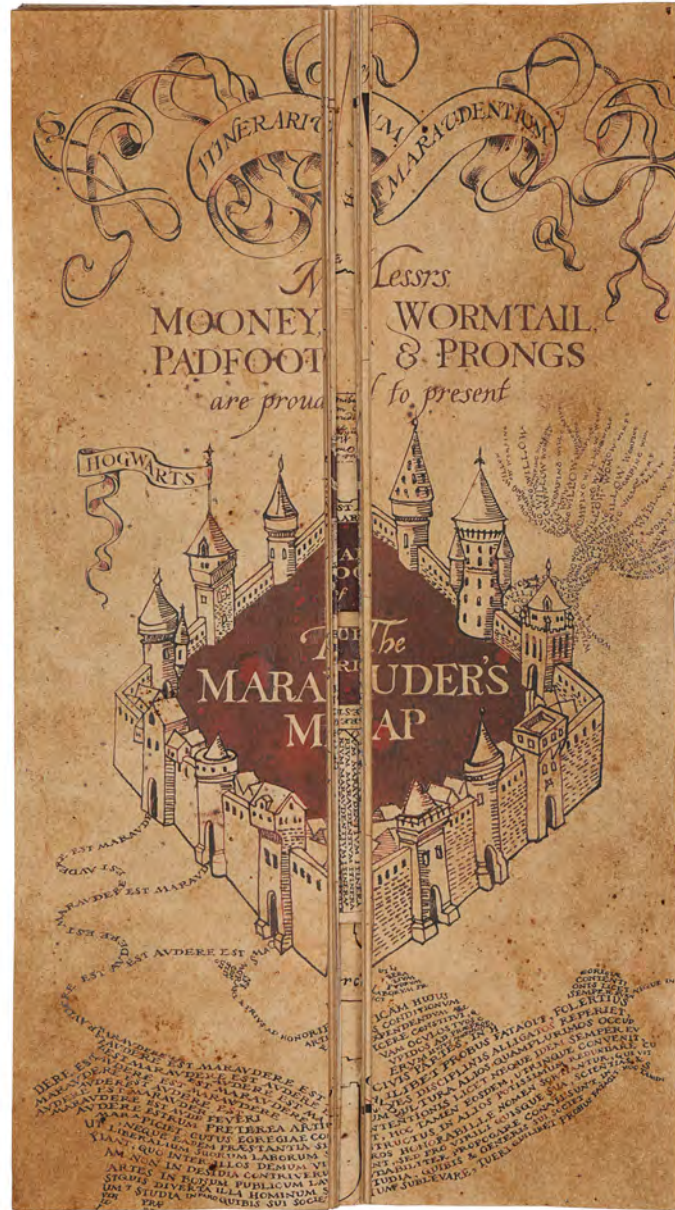

**174**  
**The Marauder's Map m**  
**Harry Potter Series (2001 - 2011)**

The Marauder's Map from the Harry Potter film series. The map made its first appearance in Harry Potter and the Prisoner of Azkaban when it was given to Harry (Daniel Radcliffe) by Fred and George Weasley (James and Oliver Phelps), who stole it from Filch (David Bradley) and used it to sneak around Hogwarts. Harry then used it in later films to track the whereabouts of teachers, students and hidden rooms and passages.

This lot originates from actor and stunt performer David Holmes, who was Radcliffe's stunt double for the first six Harry Potter films, until he suffered a serious injury on the Harry Potter and the Deathly Hallows set. He was recently the subject of the HBO documentary David Holmes: The Boy Who Lived.

David recently discovering this piece whilst doing research for his forthcoming book The Boy Who Lived, which is released on November 14th, the same day as the auction. Whilst rummaging through his memorabilia he made this miraculous discovery tucked in amongst his "get well" cards from his time at the hospital following his injury 15 years ago.

David has decided to put it up for auction so he can improve his quality of life. Living with a disability like David's is very expensive, and proceeds from the the sale will go towards helping him fund the purchase of wheelchairs and mobility equipment, along with supporting his personal care costs.

The map is printed on intentionally distressed and aged paper, replete with water stains and brown spotting. It folds out and features numerous map sections detailing areas of the school. The centre of the map features a smaller fold-out section which includes three-dimensional pop-up staircases.

The map has creasing and fold lines where it has been handled. Dimensions (folded): 40 cm x 21.5 cm (15.75" x 8.5")

**Estimate: £20,000 - 40,000**

40 cm (15.75")



Three-dimensional pop-up staircase detail



Centre of the map features a smaller fold-out section which includes three-dimensional pop-up staircases

145.5 cm (57.25")

Images (left to right) show the map progressively opening





**175**  
Slytherin House Robe  $\Omega$   
**Harry Potter And The Philosopher's Stone (2001)**

A Slytherin robe from Chris Columbus' fantasy adventure Harry Potter and the Philosopher's Stone. Hogwarts students wore their robes as part of their uniform throughout the film.

This black robe features a hood and short wide sleeves, with an embroidered Slytherin crest adorning the left breast. Pockets are incorporated into the side seams, and there is a button fastening on the front. The robe also features an internal wand pocket sewn into the lining. One of the buttons is missing, but the robe is still fastenable.

**Estimate: £5,000 - 10,000**



**176**  
Gryffindor House Robe  $\Omega$   
**Harry Potter And The Philosopher's Stone (2001)**

A Gryffindor robe from Chris Columbus' fantasy adventure Harry Potter and the Philosopher's Stone. Hogwarts students wore their robes as part of their uniform throughout the film.

The black robe features a hood and short wide sleeves, with an embroidered Gryffindor crest adorning the left breast. Pockets are incorporated into the side seams, and there is a button fastening on the front. The robe also features an internal wand pocket sewn into the lining.

**Estimate: £5,000 - 10,000**



**177**  
SFX Nimbus 2000 Broom  $\Delta$   
**Harry Potter And The Philosopher's Stone (2001)**

A SFX Nimbus 2000 broom from the production of Chris Columbus' fantasy adventure film Harry Potter and the Philosopher's Stone. Harry Potter (Daniel Radcliffe) played his first game of Quidditch while riding a Nimbus 2000, the fastest broom in the wizarding world.

The visual effects team established a method for filming flying-broomstick scenes, which was used as a blueprint for the sequels that followed. This method involved actors being individually filmed against a green screen while sitting on broomsticks fixed to motion-controlled rigs.

The broom comprises two parts: a metal handle painted to look like wood and the broom section, which is made of wood. Halfway up the underside of the handle is an attachment slot where the broom would have been fixed to a rig. Actors would have been filmed sitting on his broom, which would have also been fitted with a seat for comfort, in front of a green screen while the rig was creating motion. Dimensions: 180 cm x 22 cm x 22 cm (70.75" x 8.75" x 8.75")

**Estimate: £5,000 - 10,000**



**178**  
Gringotts Bank Scales  $M$   
**Harry Potter And The Philosopher's Stone (2001)**

A set of Gringotts Bank weighing scales from Chris Columbus' fantasy adventure Harry Potter and the Philosopher's Stone. Scales featured on the desk of every goblin working in Gringotts Bank, which Harry Potter (Daniel Radcliffe) visited with Hagrid (Robbie Coltrane) as he was preparing for his first year at Hogwarts School of Witchcraft and Wizardry.

The fully functioning scales are brass and feature fish detailing on the arms of the beam and swan detailing on the top of the pillar. Set into the base are a number of small weights, ranging from five grams to 250 grams, which can be removed and used. The scales can be dismantled into pieces for storage and transport purposes, and reassembled without tools. They exhibit some dirtying and tarnishing from age and production use, but otherwise remain in very good condition. Dimensions: 60 cm x 30 cm x 10 cm (23.75" x 11.75" x 11.75")

**Estimate: £4,000 - 8,000**





**179**  
Clapperboard m  
**Harry Potter And The Philosopher's Stone (2001)**

A clapperboard from the production of Chris Columbus' fantasy adventure Harry Potter and the Philosopher's Stone.

This acrylic clapperboard features the film title "Harry Potter" engraved along the top, as well as director Columbus and cinematographer John Seale's names near the bottom. The number "168" is handwritten in faded and smudged ink in the scene-number box, and there is smeared ink across much of the clapperboard. Dimensions: 22 cm x 28 cm x 2.5 cm (8.75" x 11" x 1")

**Estimate: £4,000 - 8,000**

**180**  
Daniel Radcliffe, Emma Watson, Rupert Grint and Other Key Cast-autographed Poster m  
**Harry Potter And The Chamber Of Secrets (2002)**

An autographed poster from the promotion of Chris Columbus' fantasy-adventure sequel Harry Potter and the Chamber of Secrets.

The one-sheet teaser poster shows Harry (Daniel Radcliffe), Hermione (Emma Watson) and Ron (Rupert Grint) with the tagline "Something Evil Has Returned to Hogwarts". It is autographed by 17 cast members from the Harry Potter franchise, namely Daniel Radcliffe, Emma Watson, Rupert Grint, Robert Pattinson, Tom Felton, Bonnie Wright, James Phelps, Oliver Phelps, Matthew Lewis, Katie Leung, Devon Murray, Jamie Waylett, Stanislav Ianevski, Clemence Poesy, Tolga Safer, Tiana Benjamin and Louis Doyle. The autographs, apart from Poesy's, are written in gold-coloured ink, and many feature their character names. The lot displays light edge wear, Blu Tack remnants on the back, and a tear in the bottom left corner. Dimensions: 101.5 cm x 68.5 cm (40" x 27")

The autographs in this lot have been professionally authenticated by expert Garry King; see notice in the Buyer's Guide.

**Estimate: £3,000 - 6,000**

**181**  
Draco Malfoy's (Tom Felton) Hero Wand m  
**Harry Potter And The Philosopher's Stone (2001)/Harry Potter And The Chamber Of Secrets (2002)**

Draco Malfoy's (Tom Felton) hero wand from the first two films in the Harry Potter film series, Philosopher's Stone and Chamber of Secrets.

Draco used his wand throughout the series, notably during his duel with Harry (Daniel Radcliffe) in Harry Potter and the Chamber of Secrets.

The wand is mostly made of straight, dark wood, with a single decorative notch next to a simple black resin handle, which tapers at the base. Draco's wand is one of the few to have retained the same design across all eight films, though in the final two instalments the wooden shaft is black, rather than brown. Dimensions: 33.5 cm x 1.5 cm x 1.5 cm (13.25" x 0.5" x 0.5")

**Estimate: £5,000 - 10,000**

**182**  
Harry Potter's (Daniel Radcliffe) Hero Wand m  
**Harry Potter And The Prisoner Of Azkaban (2004)**

Harry Potter's (Daniel Radcliffe) hero wand from Alfonso Cuarón's fantasy-adventure sequel Harry Potter and the Prisoner of Azkaban. Harry used his wand throughout the film, such as when he time travelled with Hermione (Emma Watson) and had to cast the Patronus charm to protect himself and Sirius Black (Gary Oldman) from the Dementors.

In the wizarding world, Harry's wand was made of holly with a phoenix feather core. In reality, this wand is crafted from resin finished to resemble natural wood. Dimensions: 36.25 cm x 3 cm x 2.5 cm (14.25" x 1.25" x 1")

**Estimate: £10,000 - 20,000**

**183**  
Ron Weasley's (Rupert Grint) Wand m  
**Harry Potter And The Prisoner Of Azkaban (2004)**

Ron Weasley's (Rupert Grint) wand from Chris Columbus' fantasy adventure sequel Harry Potter and the Prisoner of Azkaban. Ron bought his own wand after the one he inherited from his brother was destroyed by the Whomping Willow, and he used it in his subsequent adventures with friends Harry Potter (Daniel Radcliffe) and Hermione Granger (Emma Watson).

This wand is made of cast resin painted brown to resemble aged wood and features a roughly carved shaft and a gnarled pommel-like end. It exhibits some scuffing and paint chipping from use and has curved slightly with age. Dimensions: 36.25 cm x 3.25 cm x 3.25 cm (14.25" x 1.25" x 1.25")

**Estimate: £8,000 - 16,000**



**184**  
Professor Remus Lupin's (David Thewlis) Wand m  
**Harry Potter And The Prisoner Of Azkaban (2004)**

Professor Remus Lupin's (David Thewlis) wand from Alfonso Cuarón's fantasy-adventure sequel *Harry Potter and the Prisoner of Azkaban*. Lupin used his wand in several scenes, such as when he taught the "Riddikulus" spell during Defence Against the Dark Arts lessons, and when he used the Patronus charm to protect Harry (Daniel Radcliffe) from a Dementor.

In the wizarding world, Lupin's wand was made of cypress with a unicorn-hair core. In reality, this wand is crafted from resin finished to resemble natural wood, with a curved shaft and a textured handle. Dimensions: 34 cm x 2.5 cm x 2.5 cm (13.5" x 1" x 1")

**Estimate: £6,000 - 12,000**



**185**  
Large Countertop Chocolate Frog Box m  
**Harry Potter And The Prisoner Of Azkaban (2004)**

A large countertop chocolate frog box from Alfonso Cuarón's fantasy adventure sequel *Harry Potter and the Prisoner of Azkaban*. Harry Potter (Daniel Radcliffe) used a cloak of invisibility to sneak into Hogsmeade, and passed through the sweet shop Honeydukes, where chocolate frogs were on sale.

The pentagonal card box features gold-coloured lettering which reads "Honeydukes' Chocolate Frog 70% Finest Croakoa". The box opens along one edge, has the ingredients printed on the base, and the inside is lined with gold foil. Dimensions: 14.5 cm x 14.5 cm x 5 cm (5.75" x 5.75" x 2")

**Estimate: £5,000 - 10,000**

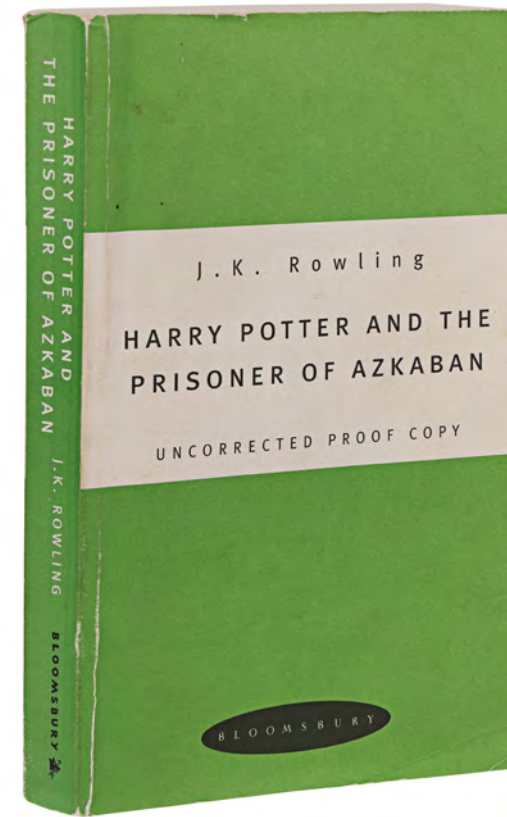

Interior detail of copyright page

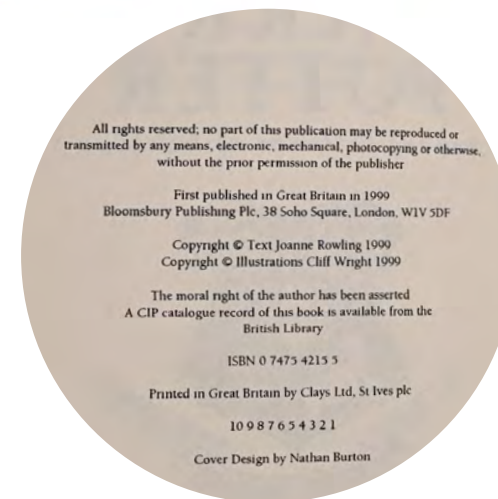

**186**  
Uncorrected Proof Copy Book m  
**Harry Potter And The Prisoner Of Azkaban (1999)**

An uncorrected proof copy of J.K. Rowling's novel *Harry Potter and the Prisoner of Azkaban*. It is the third instalment in the iconic saga of Harry's adventures at Hogwarts School of Witchcraft and Wizardry, in which he investigated the mystery of sinister prison escapee Sirius Black.

Only the first three *Harry Potter* books had proof copies printed. Based on differing reports from publisher Bloomsbury and Rowling's bibliographer Philip W. Errington, this green-covered second-state copy is one of between 150 and 250 printed. These were the final proof versions, created before trade copies were produced to send to critics. The book's front cover exhibits curling at the bottom right corner and a minor tear in the top edge. The lot is accompanied by a certificate of authenticity and additional information from *Harry Potter* specialist Adam Houston. Dimensions: 20 cm x 13 cm x 2.5 cm (7.75" x 5" x 1")

**Estimate: £10,000 - 20,000**



**187**  
Cedric Diggory's (Robert Pattinson) Hero Wand and Autographed Still m  
**Harry Potter And The Goblet Of Fire (2005)**

Cedric Diggory's (Robert Pattinson) hero wand from Mike Newell's fantasy-adventure sequel *Harry Potter and the Goblet of Fire*. Cedric used his wand throughout the Triwizard Tournament and at the graveyard in the moments leading to his murder by Wormtail (Timothy Spall).

In the wizarding world, Cedric's wand was made of ash with a unicorn hair core. In reality, this wand is crafted from resin finished to resemble natural wood, with decorative engravings on the handle.

The lot also includes an autographed still depicting Pattinson as Cedric, dressed in a Hufflepuff house Hogwarts school uniform. Pattinson has left his certified autograph on the photograph in silver-coloured marker pen. Dimensions (wand): 37 cm x 2 cm x 2 cm (14.5" x 0.75" x 0.75")

The autographs in this lot have been professionally authenticated by expert Garry King; see notice in the Buyer's Guide.

**Estimate: £8,000 - 16,000**



**188**  
Death Eater Wand m  
**Harry Potter And The Goblet Of Fire (2005)**

A Death Eater wand from the Harry Potter fantasy film series. Death Eaters used their wands throughout the saga as they collaborated with Voldemort. Art director Hattie Storey spoke of the Death Eater wands' "showy aesthetics", in contrast to the wands of the protagonist characters.

This wand is made of resin painted to look like wood, and features a curved handle, shaped into a skull. Unlike some other Death Eater wand variants, this particular style of wand has no commercially available replicas.  
Dimensions: 36 cm x 5 cm x 2.5 cm (14.25" x 2" x 1")

**Estimate: £3,000 - 6,000**



**189**  
Hermione Granger's (Emma Watson) Wand n  
**Harry Potter And The Order Of The Phoenix (2007)**

Hermione Granger's (Emma Watson) wand from David Yates' Harry Potter and the Order of the Phoenix. Granger obtained her wand before beginning her first year at Hogwarts and continued to use it both in school and outside of it, including in battle against the dark forces of Voldemort (Ralph Fiennes).

This wand is made of cast resin painted brown to resemble aged wood and features a raised vine-like embellishment twisting up the length of the shaft. It exhibits some scuffing and paint chipping from use.  
Dimensions: 38.75 cm x 1.5 cm x 1.5 cm (15.25" x 0.5" x 0.5")

**Estimate: £8,000 - 16,000**

**No lot 190**



**191**  
Hogwarts Student Gryffindor House Robe m  
**Harry Potter And The Order Of The Phoenix (2007)**

A Hogwarts student Gryffindor House robe from David Yates' fantasy-adventure sequel Harry Potter and the Order of the Phoenix. Hogwarts students wore their robes as part of their uniform, notably when Professor Trelawney (Emma Thompson) received an Order of Dismissal by Hogwarts High Inquisitor Dolores Umbridge (Imelda Staunton).

The black cotton robe (marked size "L") features a large pointed hood and short wide sleeves, with an embroidered Gryffindor crest adorning the left breast. It is lined with black synthetic fabric, with burgundy cotton lining the hood and front facings. The cloak's interior has a small pocket which seems to be designed to hold a wand. It also features an internal label reading "566, HP5", while the size label has "001" handwritten on it. The stitching has come undone on both the lining and under one armhole on the exterior. There is also plucking near the front button fastening, and the cloak exhibits minor marks.

**Estimate: £5,000 - 10,000**





**192**  
 Sirius Black's (Gary Oldman) Wand m  
**Harry Potter And The Order Of The Phoenix (2007)**

Sirius Black's (Gary Oldman) wand from David Yates' fantasy adventure sequel Harry Potter and the Order of the Phoenix.

Sirius Black used his wand throughout the film series, until his climactic death in The Order of the Phoenix at the hands of Bellatrix Lestrange (Helena Bonham Carter).

The wand is made of resin painted to look like wood, and has a distinctive handle, being squarish in shape rather than the more common rounded handles. It exhibits a twisting design along its length and rune-like engravings at the base, which are similar to those tattooed on Sirius' body, and are said to read "more or less human", hinting at his status as an animagus. Dimensions: 39 cm x 1 cm x 1 cm (15.5" x 0.5" x 0.5")

**Estimate: £5,000 - 10,000**



**193**  
 Hero Elder Wand m  
**Harry Potter And The Deathly Hallows: Part 1 (2010)**

A hero wand from David Yates' fantasy adventure sequel Harry Potter and the Deathly Hallows: Part 1. Lord Voldemort (Ralph Fiennes) raided Albus Dumbledore's (Michael Gambon) grave to steal the Elder Wand. This was one of the three magical objects that comprised the Deathly Hallows, and at various points in the series was wielded by Dumbledore, Voldemort and Harry Potter (Daniel Radcliffe) himself.

The wand is made of resin, hand-painted and finished to resemble natural wood. At the time of production, an LED in the tip of the wand could be illuminated by twisting the wand's base, when powered by three AAAA batteries. The wand has some wear from production use, including paint wear and a chip to the resin at the base of the handle, and it does not currently light up. Dimensions: 16" x 0.75" x 0.75" (40.5 cm x 2 cm x 2 cm)

Contains electronics; see electronics notice in the Buyer's Guide.

**Estimate: £12,000 - 24,000**

**194**  
 Hellboy's (Ron Perlman) Costume on Display m  
**Hellboy (2004)**

Hellboy's (Ron Perlman) costume from Guillermo del Toro's fantasy film Hellboy. Hellboy wore his costume while visiting Rasputin's (Karel Roden) mausoleum, and during the film's final climactic battle.

The costume includes a black T-shirt with a black jacket worn over the top; a pair of leather trousers; and a leather belt and holster with metal hardware (including a lucky horseshoe and a crucifix) plus a long red foam latex tail coming from the rear. The costume also features a full-length leather duster, with a leather B.P.R.D. patch and a grenade belt on the left shoulder. The grenade belt is deliberately damaged, as in the film it was broken during the fight against Rasputin and his hellhounds. A pair of black leather boots are included to complete the outfit.

Two labels are attached to the costume, which declare the numbers of the scenes it was produced for. The lot is accompanied by a resin replica Good Samaritan pistol with a leather tassel and a replica Fist of Doom, as well as a facial appliance. It is presented on a custom-made mannequin display, and the replica items also come with custom-made display stands, and are packed in their original boxes. Dimensions (displayed): 200 cm x 90 cm x 90 cm (78.75" x 35.5" x 35.5")

Restricted ownership; see replica firearm notice in the Buyer's Guide.

Special shipping required; see special shipping notice in the Buyer's Guide.

**Estimate: £20,000 - 40,000**





**195**  
**Hellboy's (Ron Perlman)**  
**Enchanted Pillory M**  
**Hellboy (2004)**

An enchanted pillory from Guillermo Del Toro's fantasy film Hellboy. Rasputin (Karel Roden) used the pillory to restrain Hellboy (Ron Perlman), before Hellboy broke it apart.

The pillory is made of wood, resin and metal, and comes deliberately broken into pieces, as it appeared in the film after Hellboy broke free. When assembled, it features three holes: one for a head, with a hand hole on either side. The hole for Hellboy's right Hand of Doom is considerably larger and ringed with resin engraved with runic symbols. The resin has been made to look metallic, and is painted to give it a rusting, verdigris effect. The wood has also been deliberately aged and dirtied. Dimensions: 85 cm x 75 cm x 20 cm (33.5" x 29.5" x 8")

**Estimate: £5,000 - 10,000**



**196**  
**Abe Sapien (Doug Jones) Upper**  
**Body and Head Prosthetics M**  
**Hellboy II: The Golden Army (2008)**

A set of Abe Sapien (Doug Jones) upper body and head prosthetics from Guillermo del Toro's action-adventure sequel Hellboy II: The Golden Army. Amphibious Abe fought alongside Hellboy (Ron Perlman) and Liz Sherman (Selma Blair) to stop Prince Nuada (Luke Goss) from reactivating the Golden Army.

This set of prosthetics was used to create Abe's entire upper body, comprising head, torso, arm and hand appliances. As an aquatic creature, Abe's skin is blue and features fins that assist with swimming. The skin is made from foam latex, while the fins are made of a translucent silicone material with ribbing running along their spines. The set is completed by a soft rubber stunt respirator with ribbed collar detailing. The prosthetics have some paint wear and minor tears in the foam latex. They are presented on a custom mannequin display which has some small scratches on the base. Dimensions (display): 37 cm x 56 cm x 186 cm (14.5" x 22" x 73.25")

**Estimate: £4,000 - 8,000**

**197**  
**Lament Configuration Puzzle Box M**  
**Hellraiser (1987)**

A Lament Configuration puzzle box from Clive Barker's horror film Hellraiser. The Lament Configuration puzzle box created a gateway to a dimension of suffering and summoned the demonic Cenobites. Frank Cotton (Sean Chapman) purchased the box at the beginning of the film, and it was eventually taken from him by Kirsty (Ashley Laurence), who ultimately banished the Cenobites by closing the box.

One of eight produced for the film, this box is made of solid oak and has ornate brass-etched panels adhered to each side. A layer of varnish is applied all over to produce a slight shine. There are some signs of light scratching and the brass etchings have broken in some places. Dimensions: 7.75 cm x 7.75 cm x 7.75 cm (3" x 3" x 3")

**Estimate: £7,000 - 14,000**



**198**  
**Pinhead (Doug Bradley) Bust M**  
**Hellraiser (1987)**

A Pinhead (Doug Bradley) promotional bust from the production of Clive Barker's British horror film Hellraiser. The bust was created by Bob Keen at Image Animation, who designed the makeup and special effects for the production, as a reference for the character's appearance.

The bust is made from fibreglass, finished in the character's bleached white skin tone. It features Pinhead's renowned carved grid pattern and fixed metal nails. Dimensions: 26 cm x 53 cm x 42 cm (10.25" x 20.75" x 16.5")

**Estimate: £2,000 - 4,000**





**199**  
**The Kurgan's (Clancy Brown) Hero Battle Armour with Screen-matched Helmet m**  
**Highlander (1986)**

The Kurgan's (Clancy Brown) hero battle armour and screen-matched helmet from Russell Mulcahy's fantasy adventure Highlander. The immortal barbarian known only as The Kurgan wore his armour while in battle with a group of Scottish warriors including Connor MacLeod (Christopher Lambert) in 1536.

This lot is the only complete hero armour set for The Kurgan known to exist, and it took the consignor more than 15 years to piece it together. The armour was designed by three-time Academy Award-winning costume designer James Acheson, whose other credits include Dangerous Liaisons, The Last Emperor, Restoration and Sam Raimi's Spider-Man trilogy. Further examination of the Kurgan helmet has achieved a screen-match through the placement of the hand-drilled holes on the right side of the head. These holes were drilled into either side of the helmet in a random pattern around the ear areas to allow Clancy Brown easier hearing on set.

Interestingly, the helmet in its existing state has two additional teeth on either side of the bottom row. The construction and finish of these teeth are different from the rest of the helmet, indicating that these were added later. One possibility is that the helmet sustained damage and was incorrectly restored based on an old design or that they were added for a scene that didn't make the final cut of the film.

The costume comprises a breastplate, a leather undershirt, a pair of leather trousers, a pair of pauldrons, a pair of elbow pieces, a belt, a right-handed bracer, a right-legged greave and thigh-armour piece, a helmet and a pair of leather boots. The inside of the breastplate's collar and armpits are lined with faux animal hair, chain mail is attached to the biceps, and faux snakeskin decorates the arm pieces.

The armour is made from fibreglass and bronze powder to give it a metallic look, and is styled to resemble animal bones. The breastplate has a hole in the front from the stab wound inflicted by Ramirez (Sean Connery) during the fight at Connor MacLeod's (Christopher Lambert) home. The reverse side of the hole contains the remains of a blood pack.

The armour has been intentionally distressed to appear well worn and battle-scarred. The costume is mounted on a custom mannequin display. Dimensions (displayed): 202 cm x 78 cm x 43 cm (79.5" x 30.75" x 17")

Special shipping required; see special shipping notice in the Buyer's Guide.

**Estimate: £50,000 - 100,000**



Scan here to see a full rotation of this lot



STUDIOCANAL FILMS LTD / Alamy Stock Photo







**200**  
The Kurgan Armour Design Illustration m  
**Highlander (1986)**

A The Kurgan armour costume design illustration from the production of Russell Mulcahy's action-fantasy Highlander.

The Kurgan wore his armour during battles with Connor MacLeod (Christopher Lambert) and Ramirez (Sean Connery) throughout the film.

This original concept design artwork for that very costume is hand-illustrated by Academy Award®-winning costume designer James Acheson, who has also signed his name in the bottom right corner of the depiction. The piece is rendered in pencil, watercolour, and ink on paper, and it features labels for the costume's different components. The piece is held inside a black wooden frame. Dimensions: 55.25 cm x 43.25 cm x 2.75 cm (21.75" x 17" x 1")

Sold without copyright; see copyright notice in the Buyer's Guide.

**Estimate: £3,000 - 6,000**



**201**  
Captain Hook's (Dustin Hoffman) Wig m  
**Hook (1991)**

Captain Hook's (Dustin Hoffman) wig from Steven Spielberg's fantasy adventure Hook. The dastardly pirate Hook wore his wig throughout the film, until Peter Banning (Robin Williams) removed it to reveal what a sad old man Hook truly was.

This curly black synthetic hair wig features grey hair streaks, a long braid wrapped with gold lame, and, tied at the top, a black ribbon with matching gold details. The wig is in overall very good condition, with loose hairs, some fraying and minor stains from wear on the interior. Dimensions: 76.25 cm x 38.25 cm x 12.75 cm (30" x 15" x 5")

**Estimate: £3,000 - 6,000**

**202**  
Duncan MacLeod's (Adrian Paul)  
Hero Sword and Scabbard m  
**Highlander (T.V. Series, 1992-1998)**

Duncan MacLeod's (Adrian Paul) hero sword and scabbard from the fantasy-action TV series Highlander. MacLeod used his sword throughout his tireless crusade against the evil Immortals.

This sword is a hero version used in close-up shots, for which the detail of MacLeod's katana needed to be on display. The blade is made of steel with a tempered hamon line along the blade edge. The weapon is dressed in traditional Japanese fashion, with a machined tsuba handguard and habaki, which provides a seal while the sword is sheathed. A brass-coloured collar secures the resin dragon-head grip, which is finished to replicate the appearance of ivory. The black scabbard is made of aluminium with a plastic grommet at the opening and black thread wrapped around the top to secure it to a belt.

The collars of the swords used in Season 3 were painted to match a different sword used in Seasons 1 and 2, with the detailing on this particular katana indicating its use in Seasons 4, 5 and 6.

This elegant weapon is accompanied by two documents from the on-set armourer confirming and detailing its history, and an additional letter from the producer of the series confirming its provenance. The sword is in excellent production-used condition, with the scabbard displaying light scratches and chips. Dimensions (sheathed): 107 cm x 8 cm x 8 cm (42" x 3" x 3")

Edged, bladed or blunt object; see notice on Blades in the Buyer's Guide.

**Estimate: £5,000 - 10,000**





**203**  
**Meet-and-Greet with Co-creator and Showrunner Ryan Condal and Autographed Script and Posters m**  
**House Of The Dragon (T.V. Series, 2022-Present)**

An in-person coffee or Zoom meet-and-greet with the co-creator and showrunner of the fantasy TV show House of the Dragon, Ryan Condal. This lot also includes autographed posters for Season 1 and 2 of the show, and an autographed Season Two script. All items are inscribed "Fire & Blood! Ryan Condal" in ink. The script - credited to Condal - is for the Season 2 episode "The Red Dragon and the Gold", which originally aired on 7 July 2024.

Condal's other credits include co-creating the sci-fi TV show Colony and writing the films Hercules (2014) and Rampage (2018), both of which starred Dwayne Johnson.

The winning bidder will be contacted after the auction to arrange a time for the coffee/Zoom call which suits all parties. The meet-and-greet will take place in London and any travel expenses incurred are the responsibility of the winning bidder. Dimensions (each poster): 102 cm x 69 cm (40.25" x 27.25")

All hammer-price proceeds from this item are being donated to the NSPCC. This lot is zero rated for VAT purposes.

No child should suffer abuse. But too many children are struggling alone with fear, violence or neglect.

This must change. At home, in school or online, every child deserves to be safe and happy.

We have shattered the silence around child abuse, and with your support we can protect children today and prevent abuse tomorrow.

The NSPCC help millions of children through Childline and our school visits. We are in every community, and we will keep fighting for young people whatever the future brings.

It is only with your support that we can be there for every child who needs us.

Together we can change children's lives.

Together we can stop abuse.

To find out more, visit [nspcc.org.uk](http://nspcc.org.uk)

**Estimate: £3,000 - 6,000**



Co-creator and showrunner of fantasy TV show House of the Dragon, Ryan Condal.



In aid of  
**NSPCC**

The NSPCC is the UK's leading children's charity fighting to end child abuse and keep children safe. They protect children at risk, help children who've been abused to rebuild their lives, and work to find the best ways of preventing child abuse from ever happening. So, whether a child needs a helping hand, a parent is finding it tough, a law needs to change, or government needs to do more, the NSPCC will be there - fighting for every childhood. We can all play a part in keeping children safe. Abuse changes childhood. But so can we. To find out more, visit [nspcc.org.uk](http://nspcc.org.uk)



**204**  
**Dr. Robert Neville's (Will Smith) Light-up M4 Carbine Rifle  **  
**I Am Legend (2007)**

Dr. Robert Neville's (Will Smith) light-up M4 carbine rifle from Francis Lawrence's post-apocalyptic action thriller I Am Legend. The M4 carbine rifle was Neville's weapon of choice while he hunted for food and protected himself and his dog Samantha from the Darkseekers.

This is a non-firing "dummy" M4 that was rented to the production so Smith could wield it without the need for an armorer on set. The rifle features a practical Trijicon ACOG scope with real glass optics, a retractable stock, a C-MORE free-floating rail, ERGO rail covers, and a charging handle. It is accompanied by a PentagonLight tactical light, a removable empty magazine and a sling. The pressure switch, which activates the functional light, is adhered to the forearm with double-sided tape so it can be moved around. The light and laser unit can be removed from the forearm and swapped to the other side (they are seen on both sides in the film). The laser is untested. Dimensions (rifle with light attached and magazine loaded): 82.5 cm x 11 cm x 31.5cm (32.5" x 4.25" x 12.5")

Restricted ownership; see replica firearm notice in the Buyer's Guide.

Contains electronics; see electronics notice in the Buyer's Guide.

**Estimate: £7,000 - 14,000**



154 cm (60.75")



LANDMARK MEDIA / Alamy Stock Photo

**205**  
 Howard Kazanjian Collection: Rene Belloq's (Paul Freeman)  
 Ceremonial Staff Ω  
**Indiana Jones And The Raiders Of The Lost Ark (1981)**

Rene Belloq's (Paul Freeman) ceremonial staff from Steven Spielberg's Raiders of the Lost Ark. In the climactic scene, Belloq held his Hebrew staff during the ritual to open the Ark of the Covenant, which resulted in catastrophic consequences for the Nazis.

With its combination of violent biblical imagery and a roaring score by Spielberg regular John Williams, the so-called "face melting" scene where the full power of the staff was revealed became an instant classic in American popular culture upon Raiders' release in 1981. Seven months later, the film received eight Academy Award® nominations, including wins for Best Visual Effects and Art & Set Direction, as well as a special award for its sound work.

Two staffs were created for the sequence by sculptor Keith Short, who sculpted them in clay before casting the final versions in fibreglass. This fibreglass staff originates directly from the collection of executive producer Howard Kazanjian.

This staff's ridged body is painted eggshell white and mounted with an ornately detailed topper sculpted with a motif of three ram's heads. The topper is metallized to resemble gilded gold-colour and applied with green verdigris to appear ancient and corroded, as is the staff's bottom, the tip of which has broken off since production. The staff exhibits some fading paint and light smudging from age and handling, though its remaining gold-colour detailing remains vibrant. Dimensions: 15.25 cm x 15.25 cm x 147.5 cm (6" x 6" x 58")

**Estimate: £60,000 - 120,000**





**206**  
Ark of the Covenant Lid  
Model Miniature  
**Indiana Jones And The Raiders Of  
The Lost Ark (1981)**

An Ark of the Covenant lid model miniature from the production of Steven Spielberg's adventure film Raiders of the Lost Ark.

This model miniature was made for the scene in which the Ark's lid was blown off during the finale. As pyrotechnic effects were used during the sequence, a number of lids were constructed for the scene. However, the shot was completed in only a few takes and the unused lids were repurposed as crew gifts.

Crafted from resin, this item resides in a custom-built display case, with a plaque featuring the film title and "Industrial Light and Magic Special Effects Crew". Dimensions: 16 cm x 15.25 cm x 6.75 cm (6.25" x 6" x 2.75")

**Estimate: £5,000 - 10,000**



52 cm (20.5")



**207**  
Kali Statue Hand  
**Indiana Jones And The Temple Of  
Doom (1984)**

A hand from the Statue of Kali from Steven Spielberg's action-adventure sequel Indiana Jones and the Temple of Doom. High Priest Mola Ram (Amrish Puri) and his Thuggee cult worshipped the Hindu goddess Kali and sacrificed people in front of her statue, which also contained the pulley system involved in the sacrifices.

This fibreglass left hand holds a skull and has been intentionally distressed to look ancient and dirty. There is an interior aluminium plate behind the skull's teeth, and a steel hinge at the back of the skull. The lot exhibits some chips and cracks revealing the fibreglass beneath, most notably on the left cheek of the skull and some of the hand's fingers. Dimensions: 52 cm x 36 cm x 30 cm (20.5" x 14.25" x 11.75")

**Estimate: £8,000 - 16,000**



**208**  
Keith Hamshere Collection: Key Set of 317  
Silver Gelatin Production Photographs  
**Indiana Jones And The Temple Of Doom (1984)**

A key set of silver gelatin photographs from the production of Steven Spielberg's action-adventure prequel Indiana Jones and the Temple of Doom. This lot comes from the personal collection of renowned stills photographer Keith Hamshere.

The lot comprises 317 black-and-white behind-the-scenes and promotional images featuring cast members Harrison Ford (Indiana Jones), Kate Capshaw (Willie Scott), Ke Huy Quan (Short Round) and Amrish Puri (Mola Ram), as well as director Steven Spielberg and producer George Lucas. This set was personally developed by Hamshere to be reviewed by the director and senior cast for their approval. Many of these images have not been seen publicly before.

Each image has a handwritten number on the reverse. Dimensions (each): 41 cm x 30.5 cm (16" x 12")

Sold without copyright; see copyright notice in the Buyer's Guide.

**Estimate: £8,000 - 16,000**



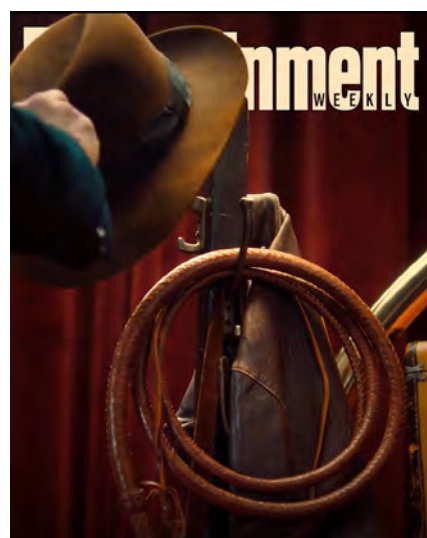
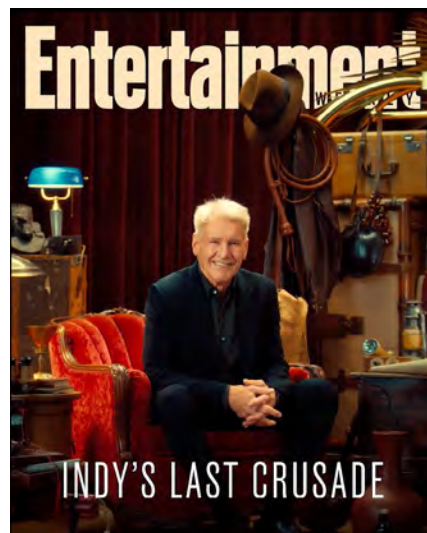

Entertainment Weekly Digital Cover

**209**  
 Indiana Jones' (Harrison Ford) Whip Replica from Entertainment Weekly Digital Cover Shoot  $\Omega$   
**Indiana Jones And The Dial Of Destiny (2023)**

A replica of Indiana Jones' (Harrison Ford) whip from an Entertainment Weekly cover shoot from the promotion of James Mangold's Indiana Jones and the Dial of Destiny. For [its 27 June 2023 digital cover shoot and interview](#) with Harrison Ford actor about his long-celebrated adventurer role, Entertainment Weekly dressed the studio with an assortment of objects representing relics from Jones' many escapades. Replicas of Jones' hat and whip, the character's two most iconic accessories considered to be essential parts of the Indiana Jones mythos, were appropriately featured front and centre during the shoot.

The film series famously used whips from David Morgan's 450 series. During the production of Kingdom of the Crystal Skull, Terry Jacka was commissioned to create additional whips to supplement the Morgan whips used on the film.

This woven brown leather bullwhip is a high-quality replica created by an unknown maker (not Morgan or Jacka) based on that classic 450 series. Acquired solely for the Entertainment Weekly shoot, it features a short-handled grip, a matching leather wrist loop, and a black nylon cracker. The whip is about 2.5 metres from the start of the handle through the end of the thong. The fall exhibits some wear to the leather, and the whip has somewhat stiffened in the rolled position. Dimensions: (rolled) 45.75 cm x 34.5 cm x 5.25 cm (18" x 13.5" x 2")

**Estimate: £6,000 - 12,000**

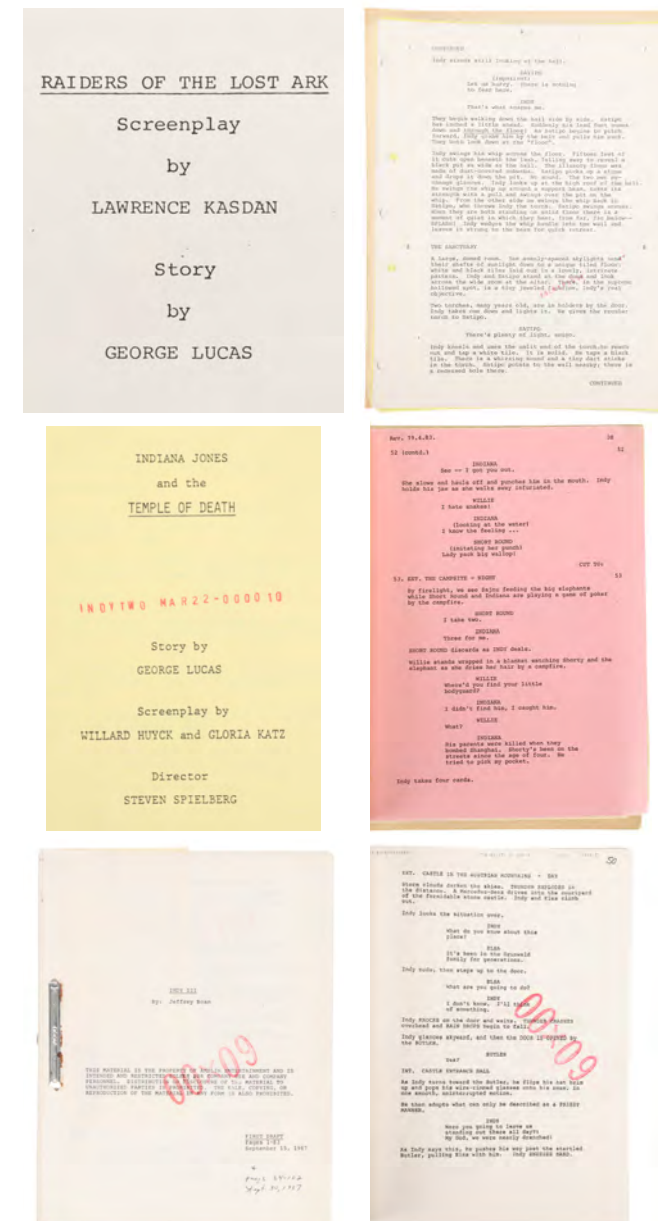

**210**  
 Director of Photography Douglas Slocombe's Set of Three Production Scripts  $\mathfrak{M}$   
**Indiana Jones: Original Trilogy (1981-1989)**

A set of three scripts previously owned by Douglas Slocombe, director of photography on Steven Spielberg's first three Indiana Jones films.

The first script is a 103-page revised fifth draft of Raiders of the Lost Ark dated "April 1980". It is unbound in a Lucasfilm Ltd. card cover, with "Douglas Slocombe" written in black marker on the front in Slocombe's own handwriting.

The second script is a 128-page revised draft dated "3/1/83" and interestingly titled "Temple of Death", with "D. Slocombe" handwritten in the top right corner of the title page in blue ink. It is accompanied by revisions for pages 23 to 127, dated "14/4/83" with "D. Slocombe" handwritten on the first page in black ink; and revisions for pages 28 to 41 dated "19.4.83". The script is bound by metal pins within a Lucasfilm Ltd. card cover with "DS" handwritten in Slocombe's hand on the front in black ink.

The third script is a 102-page first draft titled "Indy III". It is dated "September, 15, 1987" and bound by a metal fastener.

Also included is a list of locations handwritten by Slocombe in blue ink, and a printed note signed in pink ink by "Pat (Carr)," which is Patricia Carr, a production supervisor on all three of the first three Indiana Jones films. Dimensions (one script): 29.5 cm x 24 cm x 2 cm (11.5" x 9.5" x 0.75")

**Estimate: £4,000 - 8,000**



**211**  
 Shosanna Dreyfus' (Melanie Laurent) Dress  $\Omega$   
**Inglourious Basterds (2009)**

Shosanna Dreyfus' (Melanie Laurent) premiere dress from Quentin Tarantino's war film Inglourious Basterds. Shosanna wore her dress to the premiere of Nazi propaganda film Stolz der Nation, where she was shot to death by Fredrick Zoller (Daniel Bruhl), but not before enacting her plan to take down the Nazi leadership.

The dress is made from a red, crepe-like material, with zips running up the back and arms, and ruffled detailing on each side. It features three intentional marks on the chest, where Shosanna was shot. It has no size labelling, and shows some wear from production use, including light plucking and loose threads.

**Estimate: £5,000 - 10,000**



For illustrative purposes only. DB5 Vehicle is not part of this lot.



Tom Wood / Alamy Stock Photo



Tom Wood / Alamy Stock Photo

**212**  
 Legal Title for Ownership and Use of UK "J 8OND" Licence Plate †  
**James Bond Collectibles**

The legal title for ownership and use of the UK licence plate "J 8OND". By securing this lot, you secure legal ownership of, and the right to use, this unique and sought-after personalised number plate, based on the name of Ian Fleming's iconic character James Bond.

The lot includes two 'presentation' number plates – front and rear – made of acrylic. DVLA transfer will be arranged for the winning bidder, and it will be their responsibility to provide legal plates for their vehicle. It is worth noting that the numberplate "JB 007" sold at auction in 2015 for £240,000. Dimensions (each): 52 cm x 11 cm x 0.5 cm (20.5" x 4.25" x 0.25")

**Estimate: £30,000 - 60,000**



**213**  
 UK Quad †  
**James Bond: Dr. No (1962)**

A UK Quad poster from the release of Terence Young's Bond film Dr. No. This extremely rare country-of-origin poster was designed by artist Mitchell Hooks and it introduced the world to Sean Connery as James Bond, the tuxedo-wearing, Walther PPK-wielding secret agent.

The poster is conservation linen-backed with minor restoration to the fold line, border and key surface areas. The yellow background and red lettering are still bold and vibrant, and the poster is in very fine condition. Dimensions: 76 cm x 101 cm (30" x 40")

**Estimate: £10,000 - 20,000**

**214**  
 World Premiere UK Quad Advance  
 Poster m  
**James Bond: From Russia With  
 Love (1963)**

A country of origin, UK Quad Advance poster from the release of Terence Young's Bond film From Russia with Love, the second movie in this long running and iconic series. Featuring artwork designed by Eric Pulford and executed by Italian artist Renato Fratini, this premiere poster is one of the rarest Bond posters known to exist. Printed in small quantities (most likely no more than eight) for the world premiere screening at Leicester Square, London on 10th October 1963. Including this example, there are only two others we have been able to confirm exist, and they are both restored and linen-backed, whilst ours is offered in unrestored, unfolded condition. This was the only British Bond poster campaign that Fratini worked on. It differs from the standard Quad, as the title is shown in a larger dimension and is not embedded into the image.

The poster has some wear from age and storage, most notably edgewear and some spotting. Dimensions: 76 cm x 101 cm (30" x 40")

**Estimate: £10,000 - 20,000**





**215**  
British Double Crown – 007 Logo m  
**James Bond: From Russia With Love (1963)**

A British Double Crown poster from the promotion of Terence Young's Bond film From Russia with Love.

Designed by Eric Pulford and Joseph Caroff, this very rare Double Crown declares that "James Bond Is Back!" above a day-glo "007". It has been folded into quarters and has some minor markings and discolouration, most notably along the horizontal crease, where the day-glo colouring has run. Dimensions: 76 cm x 51.5 cm (30" x 20")

**Estimate: £4,000 - 8,000**

**217**  
Pair of Fort Knox Gold Bars m  
**James Bond: Goldfinger (1964)**

A pair of Fort Knox gold bars from Guy Hamilton's Bond film Goldfinger. Gold bars were seen in Fort Knox during James Bond's (Sean Connery) fight with Oddjob (Harold Sakata). After defeating Oddjob, Bond used two gold bars to break the lock off Goldfinger's (Gert Fröbe) bomb.

Both bars are made of plaster, painted to look like gold. They were purchased at the production's wrap sale and remained with the buyer for over 60 years. The bars exhibit chips to their paintwork. Dimensions (one bar): 17.25 cm x 9.5 cm x 4.5 cm (6.75" x 3.75" x 1.75")

**Estimate: £3,000 - 6,000**

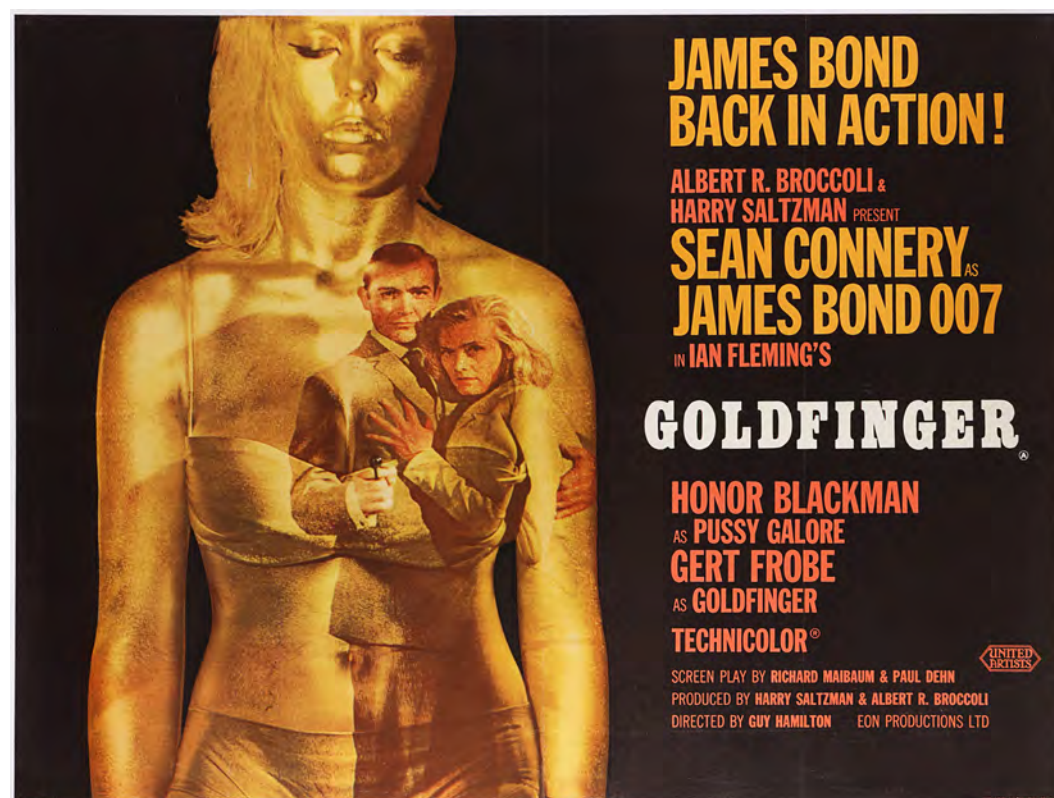

**216**  
UK Quad Poster – Style A †  
**James Bond: Goldfinger (1964)**

UK Quad Poster – Style A

A UK Quad "Style A" poster from the release of Guy Hamilton's Bond film Goldfinger. Designed by American graphic artist Robert Brownjohn, this poster refrained from the usual painted artwork approach with a photo montage, based on Brownjohn's own title sequence from the film. Actress Margaret Nolan appeared in the film as James Bond's masseuse and as the "golden girl" on both the poster and in the title sequence.

The linen-backed poster has received colour touch-ups to creasing in the corner and on the foldlines. It remains in very fine condition. Dimensions: 76 cm x 101 cm (30" x 40")

**Estimate: £4,000 - 8,000**

**218**  
UK Quad Poster †  
**James Bond: Thunderball (1965)**

A UK Quad poster from the release of Terence Young's Bond film Thunderball. After Robert Brownjohn's photo montage poster for the preceding Bond film Goldfinger, designer Robert McGinnis decided to go back to a traditional hand-painted artwork campaign, similar to those seen for Dr. No and From Russia with Love. Note how McGinnis integrated the iconic 007 logo into the "Look Out!" tagline.

This poster is conservation linen-backed with minimal restoration. There are some surface marks on the top-left and right corners but it remains in very fine condition. Dimensions: 76 cm x 101 cm (30" x 40")

**Estimate: £4,000 - 8,000**



154 cm (60.75")

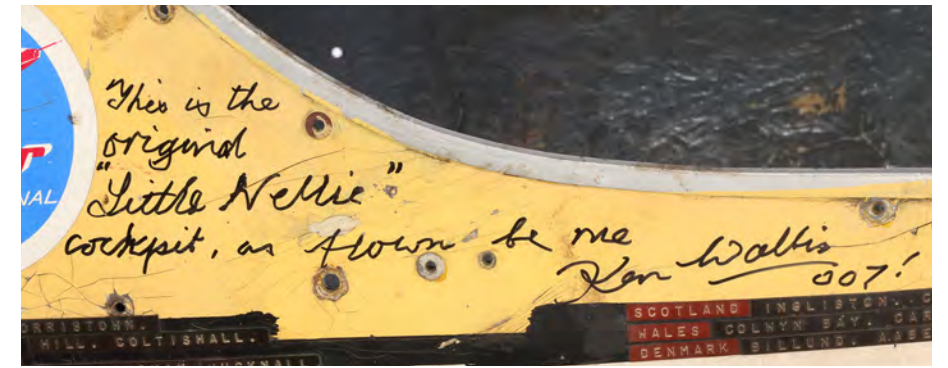

Everett Collection Inc / Alamy Stock Photo

**219**  
**Little Nellie Cockpit Nacelle m**  
**James Bond: You Only Live Twice (1967)**

The Little Nellie cockpit nacelle from Lewis Gilbert's Bond film *You Only Live Twice*. Bond (Sean Connery) flew the autogyro dubbed "Little Nellie" to locate Blofeld's (Donald Pleasence) hidden volcano base.

During the flight scenes, the autogyro was piloted by Wing Commander Ken Wallis. He swapped seats with Sean Connery straight after the earlier take off sequence featuring Q (Desmond Llewelyn). Production designer Ken Adams had heard Wallis being interviewed about autogyros on the radio one morning, and thought an autogyro would be a great fit for a Bond film.

The autogyro which became Little Nellie was already in existence before the production, but it was fitted with weaponry by Adams, Wallis and special effects artist John Stears. Only one autogyro was used for all of the outdoor filming and this is the actual cockpit nacelle from that vehicle. After the production Wallis flew the autogyro for numerous TV shows, public appearances, promotional work and air shows until 1986, when the vehicle crashed during an airshow in Northern Ireland (video footage of the incident is available online). The nacelle was damaged and was subsequently switched over for safety reasons. It is decorated with stickers from events Wallis attended, and he has autographed the nacelle on the left side, with the inscription "This is the original 'Little Nellie' cockpit, as flown by me. Ken Wallis 007!"

This is the original filming nacelle damaged on that day. Pieces of Little Nellie are not known to ever go into auction, making this an incredibly rare opportunity to own part of Bond's most distinctive vehicle.

The nacelle is made primarily of fibreglass and damage from the crash is evident all over, including holes and cracks. A support structure has been added to the nacelle since the production to help keep its shape. It is displayed on a custom-made stand and is also accompanied by a copy of the certificate of transfer between Wallis and the consignor. Dimensions: 154 cm x 56 cm x 63 cm (60.75" x 22" x 24.75")

Special shipping required; see special shipping notice in the Buyer's Guide.

**Estimate: £75,000 - 150,000**







119.5 cm (47")

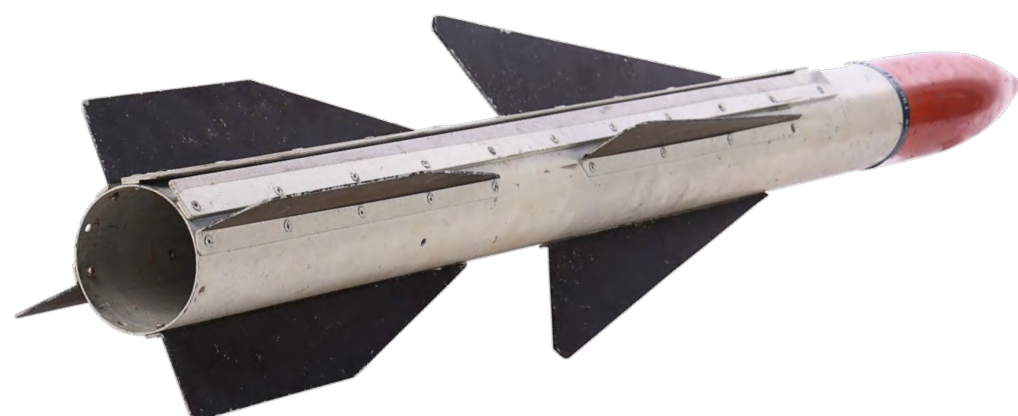

**220**  
Little Nellie Heat-seeking Missile M  
James Bond: You Only Live Twice (1967)

A Little Nellie heat-seeking missile from Lewis Gilbert's Bond film You Only Live Twice. James Bond (Sean Connery) flew the autogyro "Little Nellie" to locate Blofeld's (Donald Pleasence) hidden volcano base. When he found himself in an aerial battle against Blofeld's henchmen, he used Nellie's heat-seeking missiles to take down an enemy helicopter. This lot originated from the collection of Little Nellie's stunt pilot, Wing Commander Ken Wallis.

The missile was created for the production's battle sequences, which were filmed in Sierra Nevada, Spain (doubling for Japan). The flight sequences were filmed in Japan, however, for the actual battles and firing of missiles, Spain had to be used. The rocket motor and other pyrotechnics have been removed, and the missile has been made safe. Dimensions: 119.5 cm x 19 cm x 19 cm (47" x 7.5" x 7.5")

**Estimate: £10,000 - 20,000**

**221**  
Pair of Little Nellie Side Missiles M  
James Bond: You Only Live Twice (1967)

A pair of Little Nellie side missiles from Lewis Gilbert's Bond film You Only Live Twice. James Bond (Sean Connery) flew the autogyro "Little Nellie" to locate Blofeld's (Donald Pleasence) hidden volcano base. When he found himself in an aerial battle against Blofeld's henchmen, Bond used Little Nellie's side missiles to take down an enemy helicopter. This lot originated from the collection of Little Nellie's stunt pilot, Wing Commander Ken Wallis.

The missiles were created for the production's battle sequences, which were filmed in Sierra Nevada, Spain (doubling for Japan). The flight sequences were filmed in Japan, however, for the actual battles and firing of missiles, Spain had to be used. Each of Little Nellie's missile drums held seven missiles, and due to the large recoil when launching the missiles, they all had to be fired at once.

One missile still has the original electronics attached to the back end and both are still housed in their original dense cardboard protectors. One of the missiles has a handwritten message from Ken Wallis explaining its history. Dimensions (each): 27 cm x 4.5 cm x 4.5 cm (10.5" x 1.75" x 1.75")

Contains electronics; see electronics notice in the Buyer's Guide.

**Estimate: £4,000 - 8,000**

**222**  
Little Nellie Heat-seeking Warhead M  
James Bond: You Only Live Twice (1967)

A Little Nellie heat-seeking warhead from Lewis Gilbert's Bond film You Only Live Twice. James Bond (Sean Connery) flew the autogyro "Little Nellie" to locate Blofeld's (Donald Pleasence) hidden volcano base. When he found himself in an aerial battle against Blofeld's henchmen, he used Nellie's heat-seeking missiles to take down an enemy helicopter. This lot originated from the collection of Little Nellie's stunt pilot, Wing Commander Ken Wallis.

The warhead was created for the production's battle sequences, which were filmed in Sierra Nevada, Spain (doubling for Japan). The flight sequences were filmed in Japan, however, for the actual battles and firing of missiles, Spain had to be used. The production pyrotechnics have been removed and the missile has been made safe.

Wallis has autographed one side of the missile, with the inscription, "Gary, a 'heat-seeking missile' used on the autogyro 'Little Nellie' in 'You Only Live Twice' in Japan & Spain, 1966. Best wishes from Ken Wallis, designer & pilot of 'Little Nellie' Wallace". Nellie Wallace was a music hall star who inspired the autogyro's name. Dimensions: 36 cm x 7.5 cm x 7.5 cm (14.25" x 3" x 3")

**Estimate: £3,000 - 6,000**



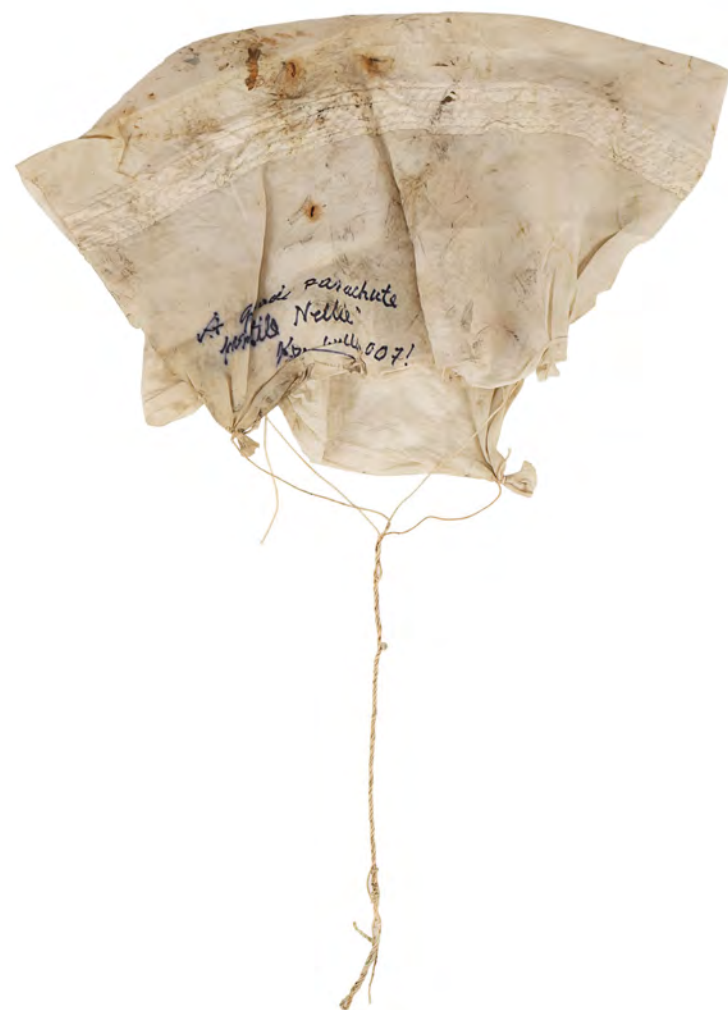

**223**  
**Little Nellie Grenade Parachute**  
**James Bond: You Only Live Twice (1967)**

A Little Nellie grenade parachute from Lewis Gilbert's Bond film You Only Live Twice. Bond flew the autogyro dubbed "Little Nellie" to find Blofeld's (Donald Pleasence) hidden volcano base and found himself in an aerial battle against Blofeld's henchmen. He used his parachute grenades to take down an enemy helicopter.

Such was their use on the production that it is remarkable that this lot has survived. This parachute is one of only two known to have survived the production, with the other currently on display in the Norfolk and Suffolk Aviation Museum. The silk parachute has been inscribed by Little Nellie's stunt pilot, Wing Commander Ken Wallis, with "A grenade parachute from 'Little Nellie'. Ken Wallis 007!" It has some staining and creasing from production and storage.

**Estimate: £2,000 - 4,000**

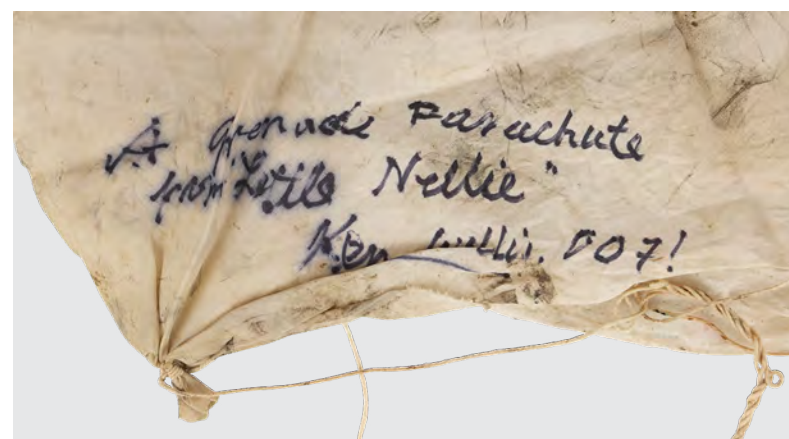

**224**  
**UK Quad Poster - Style B, Little Nellie**  
**James Bond: You Only Live Twice (1967)**

A UK Quad poster from the release of Lewis Gilbert's Bond film You Only Live Twice. This poster features artwork by American artist Frank McCarthy and shows James Bond (Sean Connery) in the cockpit of Little Nellie, the autogyro he flew while searching for Blofeld's (Donald Pleasence) hidden volcano base.

Presented with conservation linen backing, the poster exhibits very bright colours and has undergone only minor restoration along the folds. There are a few small marks in the white border but overall it presents in excellent condition. Dimensions: 76 cm x 101 cm (30" x 40")

**Estimate: £2,000 - 4,000**

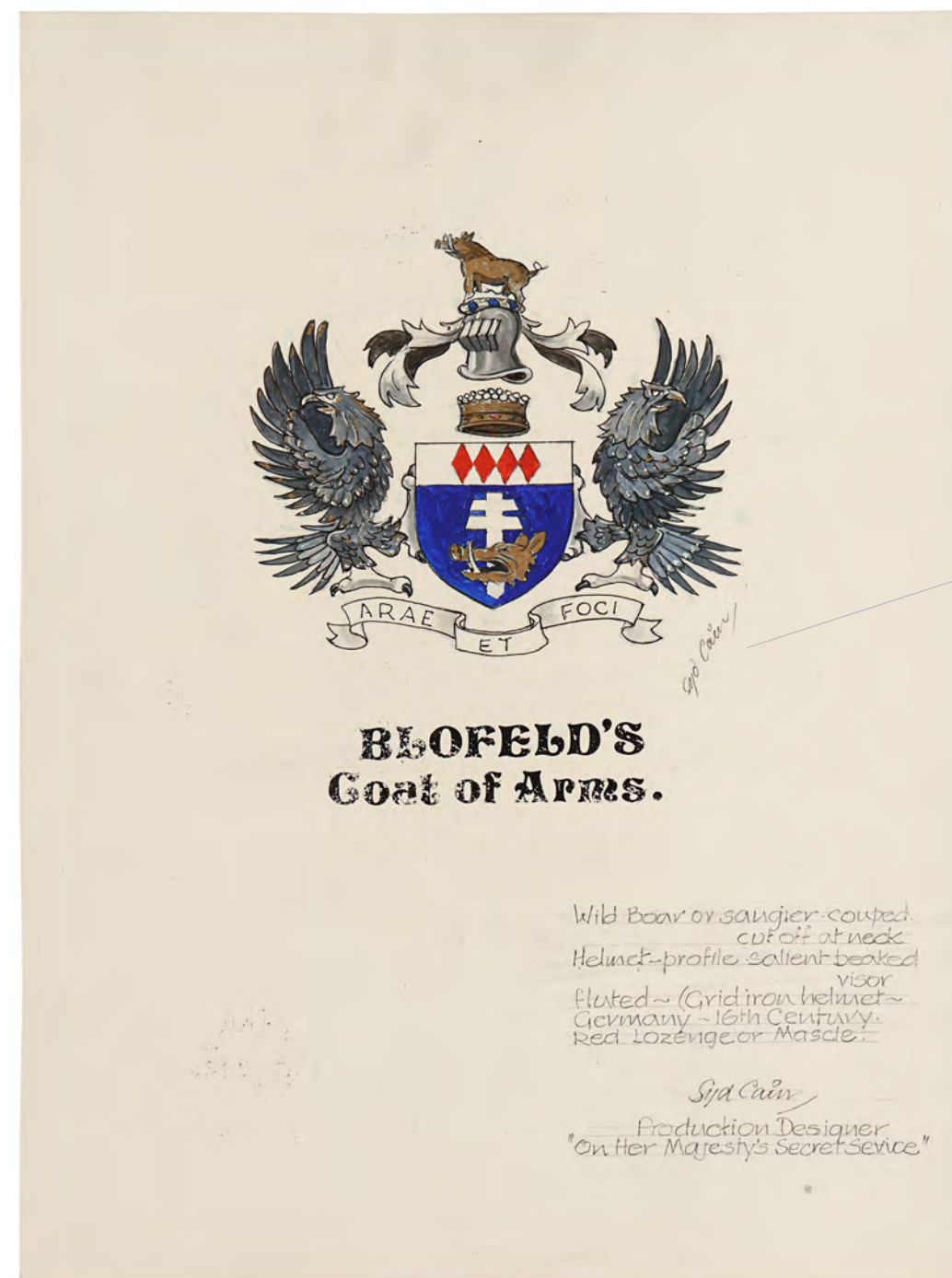

**225**  
**Syd Cain Hand-drawn Blofeld Coat of Arms Artwork**  
**James Bond: On Her Majesty's Secret Service (1969)**

A Syd Cain hand-drawn design for the Blofeld coat of arms from the production of Peter R. Hunt's Bond film On Her Majesty's Secret Service. Blofeld (Telly Savalas) was determined to prove his royal lineage and that he should be titled Count Balthazar de Bleuchamp, so Bond (George Lazenby) went undercover as genealogist Sir Hilary Bray to get close to the villain at his Alpine retreat.

Eminent art director and production designer Cain worked on many Bond films, including Dr. No and Live and Let Die, as well as Alfred Hitchcock's Frenzy. This unique piece was hand-drawn and coloured by Cain, who has produced many storyboards for Bond productions but rarely worked in colour, as he has here. Cain has signed the design twice in pencil. Dimensions: 40.5 cm x 30.5 cm (16" x 12")

Sold without copyright; see copyright notice in the Buyer's Guide.

**Estimate: £5,000 - 10,000**



80 cm  
(31.5")



**226**  
Hand-painted Robert McGinnis Poster Art Ω ARR  
**James Bond: Diamonds Are Forever (1971)**

Poster campaign artwork hand-painted by renowned artist Robert McGinnis for the promotion of Guy Hamilton's Bond film *Diamonds are Forever*. McGinnis' classic art featured in many promotional materials for the film, and he worked on several other Bond projects, including *Thunderball*, *You Only Live Twice*, *The Man with the Golden Gun* and *Live and Let Die*, also producing artwork for other classic films, such as *Breakfast at Tiffany's* and *Barbarella*.

This hand-painted piece features Bond (Sean Connery) standing, weapon drawn, between two women. When McGinnis first painted the image, Bond was the same height as the two women. When he sent it to the film's marketing department, they insisted Bond should be taller than the women, as he is the main character. With no time to start again, McGinnis carefully cut Bond out and moved him up, with the cuts still evident on the painting.

The artwork is rendered in oil and gouache, and mounted on acid-free card. It has had previous water and mould damage at the centre and more noticeably at the bottom. A section of the bottom of the artwork has also been trimmed. Dimensions: 80 cm x 60 cm (31.5" x 23.5")

Sold without copyright; see copyright notice in the Buyer's Guide.

**Estimate: £150,000 - 300,000**

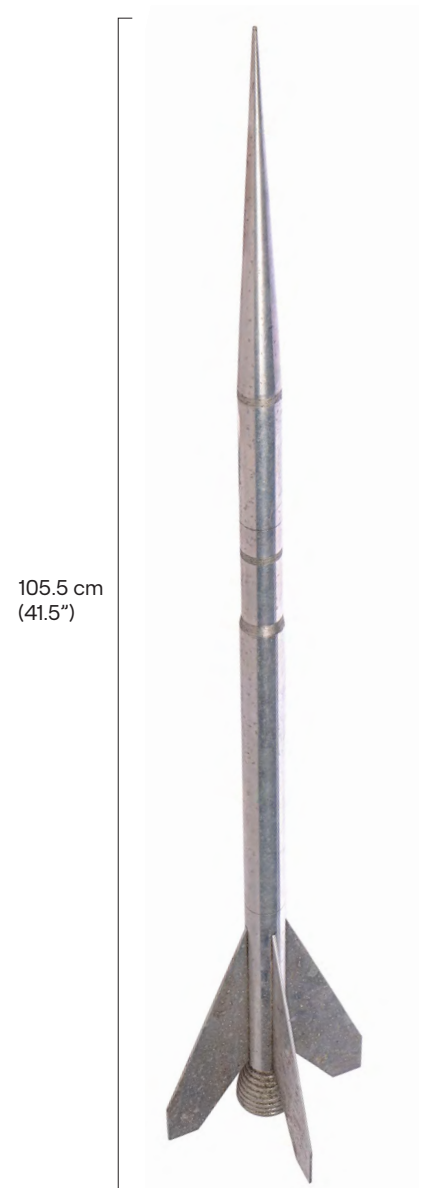

105.5 cm  
(41.5")

**227**  
Blofeld's (Charles Gray) Lair Missile m  
**James Bond: Diamonds Are Forever (1971)**

Blofeld's (Charles Gray) lair missile from Guy Hamilton's Bond film *Diamonds Are Forever*. A missile was seen in Blofeld's lair during two key scenes. The first was when James Bond (Sean Connery) broke into the lair to find the SPECTRE head with his double; the second saw Bond returning to the lair with billionaire Willard Whyte (Jimmy Dean) to try and disable Blofeld's satellite laser, which had already destroyed nuclear weapon installations in China, the US and the Soviet Union. Bond was drawn to the missile in both scenes, picking it up in the latter, and being warned by Blofeld, "That missile is not a practical weapon" in the former. The missile is made from machined aluminium, which at the time of the production was considered a high-quality metal. Dimensions: 105.5 cm x 20 cm x 20 cm (41.5" x 7.75" x 7.75")

**Estimate: £5,000 - 10,000**



**228**  
Stromberg Henchman Costume o  
**James Bond: The Spy Who Loved Me (1977)**

A Stromberg henchman costume from Lewis Gilbert's Bond film *The Spy Who Loved Me*. Stromberg's henchmen wore their uniforms throughout the film. The jacket is made from burnt orange cotton canvas with black cotton trim. It has a front zip opening and two diagonal zipped chest pockets, all made of metal. "124B2" is handwritten in black marker inside the jacket's collar. "131B" is handwritten in black marker pen on the waist interior of the matching pair of trousers.

**Estimate: £4,000 - 8,000**



**229**  
James Bond's (Roger Moore) Octopussy Palace Shirt m  
**Octopussy (1983)**

James Bond's (Roger Moore) Octopussy palace shirt from John Glen's Bond film *Octopussy*. Bond wore his shirt when he infiltrated Octopussy's (Maud Adams) palace and spoke to her. The shirt is made from cotton and has a "Frank Foster Shirtmaker & Hosier London" label inside its collar. Foster was Moore's tailor of choice.

**Estimate: £3,000 - 6,000**



**230**  
Drax Henchman Blaster with Marine Spacesuit Gloves & Cap o  
**James Bond: Moonraker (1979)**

A Drax henchman blaster with a pair of Marine spacesuit gloves and a cap from Lewis Gilbert's Bond film *Moonraker*. Drax's (Michael Lonsdale) henchmen wielded blasters onboard the villain's space station, which was raided by US Marines wearing spacesuits.

The blaster is made of resin, and has a futuristic acrylic emitter nozzle fixed into the muzzle. Different versions of this blaster are seen in the movie. For example, James Bond (Roger Moore) was held at gunpoint by Drax's henchmen, who wielded a version of the blaster without the acrylic nozzle. Meanwhile, Drax himself and Holly Goodhead (Lois Chiles) are seen with versions that feature the nozzle, as well as additional greebles and silver-coloured bands.

The spacesuit gloves are made of faux leather painted silver to represent synthetic material. Each glove has a resin cuff and a red cotton interior. The cap is also made of faux leather with a woollen inner lining that features a "Jean Barthelet" label, indicating it has been converted from a hat by the prominent milliner.

The left glove exhibits some minor staining on the knuckle area. Dimensions (blaster): 30 cm x 15 cm x 5.5 cm (11.75" x 6" x 2.25")

**Estimate: £3,000 - 6,000**



**231**  
James Bond (Roger Moore) Miniature Figure m  
**James Bond: For Your Eyes Only (1981)**

A James Bond (Roger Moore) miniature figure from the production of John Glen's Bond film *For Your Eyes Only*. While climbing the rocky precipice on which St. Cyril's monastery was located, Bond dispatched Kristatos' (Julian Glover) henchman, Apostis (Jack Klaff).

This miniature was designed for this sequence by visual effects supervisor Derek Meddings and his team. Miniatures were used for the wide shots of Bond scaling the precipice, while live-action shots were used for the close-ups. The miniature has a foam torso wrapped in blue plastic tape. The arms and head are made of resin, with the former covered in cotton sleeves, while the legs are made of wood. The arms and legs remain poseable. Dimensions: 16 cm x 6 cm x 2.25 cm (6.25" x 2.25" x 1")

**Estimate: £5,000 - 10,000**

**232**

**Xenia Onatopp's (Famke Janssen) Stunt Walther PPK Pistol and Shoulder Holster M**  
**James Bond: Goldeneye (1995)**

Xenia Onatopp's (Famke Janssen) stunt Walther PPK pistol and holster from Martin Campbell's Bond film Goldeneye. This gun was one of two stunt pistols provided by the costume department for Janssen to use in a photoshoot with photographer Terry O'Neill at Leavesden Film Studios.

Goldeneye stunt pistols were refurbished for James Bond (Pierce Brosnan) to use as holster fillers both during the Tiger Eurocopter theft sequence and in the next Bond film Tomorrow Never Dies, which also reutilised the Galco EX204 shoulder holster included in this lot.

The holster was cut down and suede backed for the Paris Calver hotel room sequence (filmed at the Stoke Poges Ballroom) in Tomorrow Never Dies. It was common practice to modify commercially available holsters during both Brosnan's and Daniel Craig's tenures as 007.

The pistol is primarily made of resin, and T-Cut was applied to its slide during post-production to reveal the paint-obscured serial number "G004292". The shoulder holster was obtained in 2006 from the film and television armourer Bapty Ltd.

The lot is accompanied by a photo of Janssen from the Leavesden shoot autographed by the actress, and a copy of 007 The Armoury - An Unofficial Concise Guide Celebrating 60 Years of James Bond's Weapons on the Silver Screen by John E. Reynolds. This weapon appears on pages 92 and 93. Dimensions (pistol): 15 cm x 11.5 cm x 3 cm (6" x 4.5" x 1.25")

Restricted ownership; see replica firearm notice in the Buyer's Guide.

The autograph in this lot has been professionally authenticated by expert Garry King; see notice in the Buyer's Guide.



**Estimate: £6,000 - 12,000**

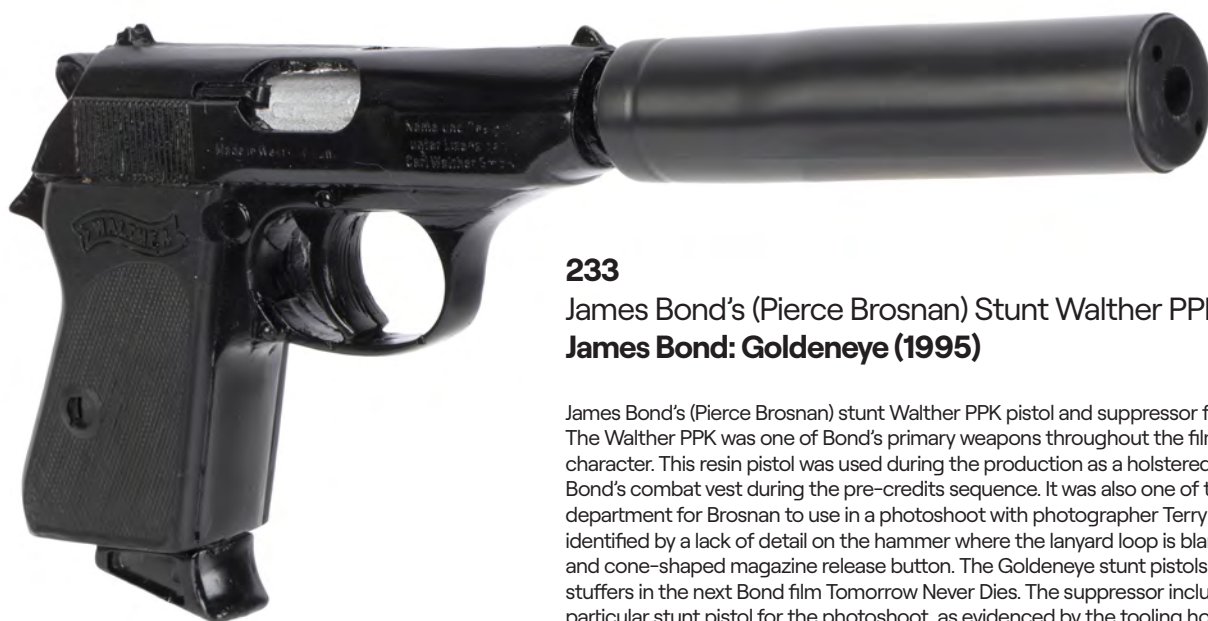

**233**

**James Bond's (Pierce Brosnan) Stunt Walther PPK Pistol and Suppressor M**  
**James Bond: Goldeneye (1995)**

James Bond's (Pierce Brosnan) stunt Walther PPK pistol and suppressor from Martin Campbell's Bond film Goldeneye. The Walther PPK was one of Bond's primary weapons throughout the film, and the pistol is synonymous with the character. This resin pistol was used during the production as a holstered stunt weapon, glued into the holster of Bond's combat vest during the pre-credits sequence. It was also one of two stunt pistols provided by the costume department for Brosnan to use in a photoshoot with photographer Terry O'Neill at Leavesden Film Studios. It can be identified by a lack of detail on the hammer where the lanyard loop is blanked, with flatter grips, magazine finger spur, and cone-shaped magazine release button. The Goldeneye stunt pistols were refurbished for Brosnan to use as holster fillers in the next Bond film Tomorrow Never Dies. The suppressor included in this lot was incorrectly paired with this particular stunt pistol for the photoshoot, as evidenced by the tooling holes either side of the central bore being at the "10" and "4" positions, rather than the correct "9" and "3" positions. Interestingly, the tooling holes do line up to the correct "9" and "3" positions on the stunt PPK used by Famke Janssen as Xenia Onatopp. The lot is accompanied by a photograph of Brosnan from the Leavesden shoot which is autographed in black ink by Brosnan, and a copy of 007 The Armoury - An Unofficial Concise Guide Celebrating 60 Years of James Bond's Weapons on the Silver Screen by John E. Reynolds. This weapon appears on pages 92 and 93. Dimensions (pistol with silencer): 26 cm x 11.5 cm x 3 cm (10.25" x 4.5" x 1.25")

Restricted ownership; see replica firearm notice in the Buyer's Guide.

The autograph in this lot has been professionally authenticated by expert Garry King; see notice in the Buyer's Guide.

**Estimate: £5,000 - 10,000**



**234**

**James Bond's (Pierce Brosnan) Gilet M**  
**James Bond: Goldeneye (1995)**

James Bond's (Pierce Brosnan) gilet from Martin Campbell's Bond film GoldenEye. Bond wore a gilet during the film's final sequence, in which he and Natalya (Izabella Scorupco) travelled to Cuba in search of Goldeneye programmer Boris Grishenko (Alan Cumming).

This tan gilet is made from cotton with a nylon inner lining, and features pink threaded trim and a metal zip down the centre of the torso. One edge of the top pocket located on the right side of the chest has detached from the main body of the gilet.

**Estimate: £4,000 - 8,000**

**235**

**James Bond's (Pierce Brosnan) Blank-Firing Hero Walther P99 Pistol M**  
**James Bond: The World Is Not Enough (1999)**

James Bond's (Pierce Brosnan) blank-firing hero Walther P99 pistol from Michael Apted's Bond film The World is Not Enough. Bond used his P99 throughout the film, and wielded a decoy version in the opening scene, which was revealed to be a stun grenade.

This is a real, deactivated semi-automatic 9mm pistol made of steel with a glass fibre-reinforced polymer frame. Its trigger and slide are still functioning, and a button on the bottom of the trigger guard allows the empty magazine to be extracted and reloaded. The gun's serial number is 011047.

The accompanying display stand comprises a wooden interior covered in several plastic panels that have been expertly painted silver. The lot also includes a letter of authenticity from the original provider to the film, Bapty Limited, and a deactivation certificate issued by Birmingham Gun Barrel Proof House. Dimensions (gun): 18.5 cm x 3 cm x 14 cm (7.25" x 1.25" x 5.5"); (gun on stand): 28.25 cm x 25.75 cm x 9.5 cm (11" x 10" x 3.75")

Firearm deactivated; see firearm deactivation notice in the Buyer's Guide.

Restricted ownership; see replica firearm notice in the Buyer's Guide.

**Estimate: £7,500 - 15,000**





**236**

**James Bond's (Pierce Brosnan) Full-size Q-Boat m  
James Bond: The World Is Not Enough (1999)**

A full-size Q-Boat driven by James Bond (Pierce Brosnan) in the opening scenes of Michael Apted's spy film The World is Not Enough. This jet boat was used in the high-speed chase along London's River Thames, regarded as one of the best chase sequences in the series. Designed by Q division, the highly manoeuvrable, computer-controlled boat was a sophisticated, powerful and well-armoured vessel, which featured GPS navigation and a full array of torpedoes and machine guns.

Initially conceived by production designer Peter Lamont, 15 Q Boat shells were constructed for filming by Riddle Marine of Idaho, USA. The shells were shipped to the UK and detailed in the workshops of Pinewood Studios. This and three of the other boats were functioning and operational, powered by enormous 5.7L V8 engines. The rest were designed for specific purposes, including the barrel roll, underwater filming, and SFX cannon shots. Only nine of the boats remain today, and can usually only be found in museums and touring exhibitions.

This particular Q Boat was specifically constructed for use in the pre-title sequence. The original filming canopy was removed after filming, but everything that remains is true to the production, including the driver's green racing seat, steering wheel, basic instrumentation, and watertight Chevy engine. The current owner has made several repairs and restorations, including (but not limited to) a new fuel filter, a new high-pressure fuel pump, a new battery and new spark plugs. A complete list of repairs and replacements can be found in the online description. Dimensions: 5 m x 1.6 m x 1.6 m (16' 4" x 5' 2" x 5' 2")

Contains electronics; see electronics notice in the Buyer's Guide.

Special shipping required; see special shipping notice in the Buyer's Guide.

Contains mechanical components; see mechanical notice in the Buyer's Guide.

**Estimate: £7,500 - 15,000**

**237**

**Elektra King's (Sophie Marceau) Death Scene Costume m  
James Bond: The World Is Not Enough (1999)**

Elektra King's (Sophie Marceau) death scene costume from Michael Apted's Bond film The World is Not Enough. Oil heiress King wore her costume for her final scenes in the film, as she tortured James Bond (Pierce Brosnan) before he escaped and ultimately killed her. This costume was previously exhibited in the Louvre, Paris in March 2002, as part of a Versace exhibition. Versace designed the skirt and Emanuel Ungaro designed the top.

The two-piece costume comprises a lace mesh top decorated with an embroidered floral design made of beads and sequins, and a long dark grey silk skirt. EON Productions originally offered the dress as a charity item to raise money for the National Film and Television School, and it is accompanied by a letter of authenticity from EON.

**Estimate: £10,000 - 20,000**

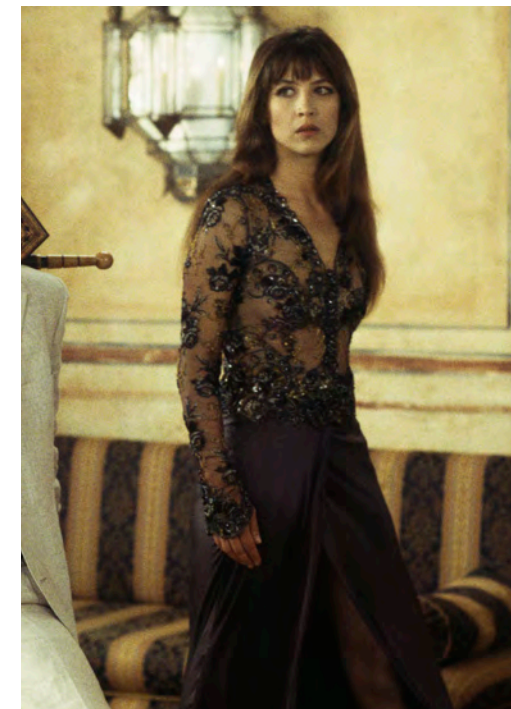

Keith Hamahere / Contributor





**238**  
 Robert King's (David Calder)  
 Lapel Pin M  
**James Bond: The World Is Not  
 Enough (1999)**

Sir Robert King's (David Calder) lapel pin from Michael Apted's Bond movie *The World Is Not Enough*. Sir Robert wore his lapel pin during his visit to MI6, where the pin triggered the explosion that killed him. When it is later revealed that his pin was switched to a duplicate containing the transmitter that caused the explosion, King's daughter Elektra (Sophie Marceau) presents M (Judi Dench) with the real pin, explaining he would have wanted her to have it.

The pin is made of metal in a Celtic knot design, set with three circular green enamel plaques, two with triangular symbols and one featuring the letter "K". The box is green with a gold-coloured border detail and interior padding. Dimensions (box): 10 cm x 4.5 cm x 2 cm (4" x 1.75" x 0.75")

**Estimate: £3,000 - 6,000**



**239**  
 SFX Aston Martin V12 Vanquish  
 Front End, Numberplate and  
 Front Seats †Δ  
**James Bond: Die Another Day  
 (2002)**

The SFX front end, numberplate and front seats of an Aston Martin V12 Vanquish from Lee Tamahori's Bond film *Die Another Day*. This segment of the vehicle was created for the scene where Bond (Pierce Brosnan) used it to smash into the flooded ice palace room to save Jinx (Halle Berry).

The front end is painted tungsten silver and features an Aston Martin badge; a grille; a bumper; a bonnet; fenders; dual headlights with electrical wiring; dual fog lights; and the numberplate KE02 EWW. Holes are present in the numberplate where spikes assisted the wall breach. Also included in the lot are two black leather seats with lavender-coloured diamond-stitch upholstery and an Aston Martin label at the base. "8/3/1616 AN + MDR" and "BD 99/161" are handwritten inside the front end. Discarded at the end of production, the components have been re-assembled on a custom-made metal frame. The lot exhibits signs of wear from production use, including scratches and dents in the panelling, and damage to the numberplate. The seats exhibit creases, stains, scuff marks and minor damage. Dimensions: 172 cm x 111 cm x 103 cm (68" x 43.75" x 40.5")

Contains electronics; see electronics notice in the Buyer's Guide.

Special shipping required; see special shipping notice in the Buyer's Guide.

**Estimate: £8,000 - 16,000**

**240**  
 James Bond's  
 (Pierce Brosnan) Passport M  
**James Bond: Die Another Day  
 (2002)**

James Bond's (Pierce Brosnan) passport from Lee Tamahori's Bond movie *Die Another Day*. Under the alias Alex Smith, Bond presented his passport on arrival in Cuba, where the trail of a terrorist developing a deadly space weapon had led him.

This paper passport features a dark red plastic cover that accurately replicates a real passport. Inside, it features Bond's photo and personal information for "Alex Smith". The passport comes complete with a custom built display stand. Dimensions (on display): 22 cm x 17.5 cm x 17 cm (8.75" x 7" x 6.75")

**Estimate: £3,000 - 6,000**



**241**  
 Tang Ling Zao's (Rick Yune)  
 Hero Bullet Necklace with  
 Faux Diamonds †Δ  
**James Bond: Die Another Day  
 (2002)**

Tang Ling Zao's (Rick Yune) hero bullet necklace from Lee Tamahori's Bond film *Die Another Day*. Zao wore a distinctive necklace with a bullet pendant. Bond (Pierce Brosnan) used the diamonds stored inside the pendant to uncover a cache of conflict diamonds belonging to Gustav Graves (Toby Stephens).

The aluminium bullet and its brass shell casing are attached to a metal chain. The top of the bullet unscrews, revealing four faux diamonds inside the casing. Dimensions (pendant): 6.5 cm x 1 cm x 1 cm (2.5" x 0.5" x 0.5")

**Estimate: £3,000 - 6,000**



Faux diamonds contained inside the necklace.



**242**  
 Casino Royale \$1,000,000 Poker Plaque m  
**James Bond: Casino Royale (2006)**

A \$1,000,000 casino plaque from Martin Campbell's Bond film Casino Royale. James Bond (Daniel Craig), Le Chiffre (Mads Mikkelsen), and their fellow poker players used betting plaques during the high-stakes game at the Casino Royale in Montenegro.

This plaque is made of blue pearlescent plastic with a translucent red and yellow centre and "Casino Royale \$1,000,000 Montenegro" printed on both sides in gold and black coloured text. The plaque was bought at the James Bond 50th Anniversary Christies auction. Dimensions: 12 cm x 8 cm x 0.5 cm (4.75" x 3.25" x 0.25")

**Estimate: £4,000 - 8,000**



**243**  
 Casino Royale \$500,000 Poker Plaque m  
**James Bond: Casino Royale (2006)**

A \$500,000 poker plaque from Martin Campbell's Bond movie Casino Royale. James Bond (Daniel Craig), Le Chiffre (Mads Mikkelsen) and their fellow poker players used betting chips during the high-stakes game at the Casino Royale in Montenegro.

The chip is made of red pearlescent plastic and has a translucent green centre. "Casino Royale \$500,000 Montenegro" is printed on both sides in a gold-and-black font. Dimensions: 10.75 cm x 7.5 cm x 0.75 cm (4.25" x 3" x 0.25")

**Estimate: £4,000 - 8,000**

**244**  
 James Bond's (Daniel Craig)  
 "Sixty Years of James Bond: Part II -  
 Online Auction" Tom Ford Suit m  
**James Bond: Skyfall (2012)**

James Bond's (Daniel Craig) Tom Ford suit from Sam Mendes' Bond film Skyfall. Bond wore his suit in the opening action sequence, as he chased the mercenary Patrice (Ola Rapace) through Istanbul, first on a motorbike across roofs and then along a moving train. Skyfall was nominated for five Academy Awards, the most ever for a Bond film. This suit was originally sold by Christie's in their "Sixty Years of James Bond: Part II - Online Auction" in 2022, having been consigned directly by EON Productions Ltd. Fashion designer and film director Tom Ford designed Bond's suits for the four most recent films in the series, starting with Quantum of Solace (2008), and all of Bond's clothing was custom-made for Skyfall. The grey two-piece rayon-and-silk suit features an embroidered tag in the inside right pocket reading "Daniel Craig Bond 23". It is accompanied by a white Tom Ford shirt with French cuffs; a Tom Ford silver-grey tie; and a pair of Tom Ford cufflinks. The jacket is labelled size "48F" and the trousers "32". The suit jacket exhibits some wear and plucking on the front right.

Additional provenance: This suit was previously sold by Christie's in their "Sixty Years of James Bond: Part II - Online Auction", which took place between 15 September and 5 October 2022.

**Estimate: £20,000 - 40,000**



Embroidered tag in the inside right pocket reading "Daniel Craig Bond 23".



Collection Christophel / Alamy Stock Photo





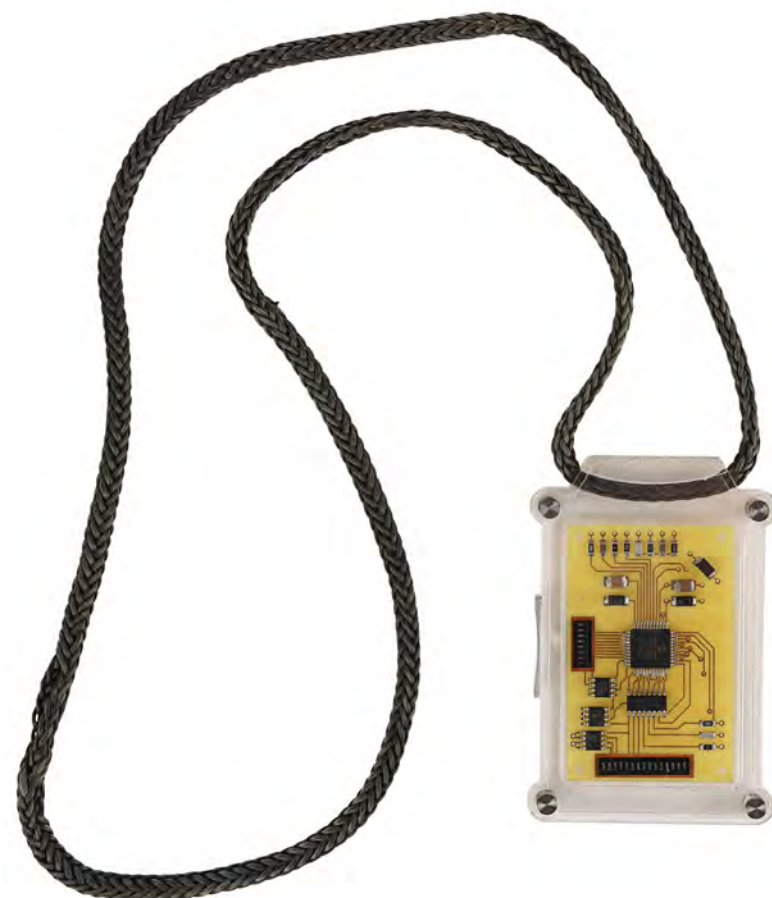

**245**  
Patrice's (Ola Rapace) Screen-matched Hero Hard Drive  
**James Bond: Skyfall (2012)**

Patrice's (Ola Rapace) screen-matched hero hard drive from Sam Mendes' Bond movie Skyfall. Patrice and Bond (Daniel Craig) fought over the hard drive atop a moving train in Istanbul, which resulted in Patrice escaping after Eve Moneypenny (Naomie Harris) accidentally shot Bond.

The hard drive is made of yellow plastic and sealed in a clear acrylic case, which does not open. A blemish in the acrylic casing matches the hard drive to close-up shots of Bond trying to wrestle it from Patrice. The case hangs from a cord so that it can be worn around the neck. Also included is an autograph card signed by Ola Rapace. Dimensions: 10.5 cm x 7.5 cm 1 cm (4.25" x 3" x 0.5")

**Estimate: £8,000 - 16,000**



**246**  
James Bond (Daniel Craig) Stunt Watch and Design m  
**James Bond: Spectre (2015)**

James Bond's (Daniel Craig) stunt watch and a piece of concept art from Sam Mendes' Bond movie Spectre. Bond used his watch as an explosive device to escape from Blofeld's (Christoph Waltz) neurosurgical torture.

The watch is made of plastic, and is a copy of an Omega Seamaster 300, complete with a grey-and-black NATO strap. This strap is reminiscent of the one worn by Sean Connery's Bond in Goldfinger and Thunderball - though originally it was attached to a Rolex, with Omega watches only becoming favoured by the character since Pierce Brosnan took it over in 1995. Omega released the watch as a limited edition model, of only 7,007 copies, after the film's release. The face of the watch is warped and shows significant wear from production.

Also included in the lot is a watch stand for display purposes and a printed concept artwork that explains the watch's explosive functionality. Dimensions: 23.5 cm x 10 cm x 10 cm (9.25" x 4" x 4")

**Estimate: £10,000 - 20,000**



**247**  
Daniel Craig, Christoph Waltz and Cast-autographed Poster m  
**James Bond: Spectre (2015)**

A one-sheet from the promotion of Sam Mendes' Bond film Spectre, signed by leading cast members.

This international-style one-sheet, which depicts Bond in a tuxedo and in his Day of the Dead skull-faced costume in the background, is signed in gold marker by Daniel Craig (James Bond), Christoph Waltz (Blofeld), Ralph Fiennes (M), Naomie Harris (Moneypenny), Ben Whishaw (Q), Rory Kinnear (Tanner), Dave Bautista (Hinx), Andrew Scott (C) and Mendes. Dimensions: 101.25 cm x 69 cm (39.75" x 27.25")

The handwriting in this lot has been professionally authenticated by expert Garry King; see notice in the Buyer's Guide.

**Estimate: £1,000 - 2,000**



Entertainment Pictures / Alamy Stock Photo

**248**  
 Paloma's (Ana de Armas) "Hero #1" Dress and Sandals  
 with EON Certificate of Authenticity †Δ  
**James Bond: No Time To Die (2021)**

Paloma's (Ana de Armas) dress and sandals from Cary Joji Fukunaga's Bond film No Time to Die. Paloma wore her dress and sandals when she teamed up with James Bond (Daniel Craig) in Cuba to infiltrate a SPECTRE party and extract MI6 scientist Dr Valdo Obruchev (David Dencik). The dress also appeared in Paloma's character poster during the promotion of the film.

The designer Michael Lo Sordo "Alexandra" navy blue silk dress and the silver Aquazzura high-heeled sandals both feature production tags labelling them "Hero #1". The lot is accompanied by a certificate of authenticity from EON Archive Director Meg Simmonds.

**Estimate: £12,000 - 24,000**



**249**  
 James Bond's (Daniel Craig) Vuarnet  
 Sunglasses with EON Certificate  
 of Authenticity †Δ  
**James Bond: No Time To Die (2021)**

James Bond's (Daniel Craig) Vuarnet sunglasses from Cary Joji Fukunaga's Bond film No Time to Die. Bond wore his sunglasses while using a submersible glider to infiltrate Safin's (Rami Malek) headquarters.

The sunglasses are Vuarnet Edge 1613 frames, and come with their original blue Vuarnet case, paperwork and lens cloth. Craig also wore Edge 1613 sunglasses to a number of public events during filming, including the British Grand Prix in 2019. Also included is a costuming label, which details the character, actor, scene number and a description of the item, as well as a certificate of authenticity from the archive director of EON. Dimensions: 18 cm x 7.5 cm x 7.5 cm (7" x 3" x 3")

**Estimate: £5,000 - 10,000**



**250**  
 The Creeper's (Jonathan Breck)  
 Head, Hands, and Boots M  
**Jeepers Creepers (2001)**

The Creeper's (Jonathan Breck) head, and boots from Victor Salva's horror film Jeepers Creepers. The ancient Creeper wore his boots while terrorising siblings Trish and Darry Jenner (Gina Philips and Justin Long) as they drove through Florida.

This lot consists of a dark green foam latex facial appliance with a cowl accent and black resin mandible, two pairs of dark grey foam latex hands; and a pair of black leather and rubber boots with cloth details. The appliance comes mounted on a black bust, which has been autographed in gold ink by Breck, while one set of hands comes on a custom wood-and-plastic display stand autographed in gold ink by makeup design supervisor Brian Penikas. Alongside his signature, Penikas has written, "Wes, Hands up! Keep on Creepin!". The autograph on the bust is dated 2006, while the autograph on the hands is dated 2007. The lot has been sympathetically restored to stabilise the hardened foam on the appliance and the undisplayed pair of hands. It nonetheless exhibits extensive ageing throughout, with holes and grime intentionally applied by production to the cowl and boots. Dimensions: 51 cm x 51 cm x 51 cm (20" x 20" x 20")

**Estimate: £7,500 - 15,000**



**251**  
**Hero Light-up Lawgiver Mark II Pistol m**  
**Judge Dredd (1995)**

A hero light-up Lawgiver Mark II pistol from Danny Cannon's sci-fi adventure Judge Dredd. The Lawgiver, the signature weapon of Judge Dredd (Sylvester Stallone) and the Street Judges who patrolled Mega-City One, only operated when its rightful owner wielded it.

Hero versions of this iconic weapon were constructed around Beretta 92FS pistols modified to fire blanks for filming. The resin shroud is painted black with silver-coloured detailing, with added rubber pistol grips, a turned aluminium barrel extension, and a machined aluminium magazine. A vented sight post, ribbed housing, and the Hall of Justice crest are added to the body. The pistol lights up on the right side when a switch on the left side near the trigger is activated. This Lawgiver exhibits some signs of production use, including slightly shrunken rubber grips, some paint wear, and minor nicks to the resin. Dimensions: 28 cm x 18 cm x 4.5 cm (11" x 7" x 1.75")

Contains electronics; see electronics notice in the Buyer's Guide.

Firearm deactivated; see firearm deactivation notice in the Buyer's Guide.

**Estimate: £10,000 - 20,000**

**252**  
**Judge Dredd's (Sylvester Stallone)**  
**Screen-matched Fargo**  
**Shotgun Components us**  
**Judge Dredd (1995)**

Judge Dredd's (Sylvester Stallone) screen-matched Fargo shotgun components from Danny Cannon's Judge Dredd. Distress points in the finish of these components screen-match to when Dredd first took up his mentor's, Judge Fargo's (Max von Sydow), shotgun in his hunt for Rico (Armand Assante).

These components were designed as futuristic dressing for Fargo's blank-firing shotgun. They consist of a black fibreglass grip, barrel, and tube inset with an aluminium muzzle and two side hooks; a foam rubber-padded pump with a metal interior; and a black leather shoulder strap with a metal buckle and rivets. The underside of the barrel is etched "17" and inset with wiring for connecting to a battery. Fastening strips are applied throughout the barrel and strap.

Following production, the wiring was cut, rendering the components nonfunctional. They exhibit fractures and missing components, including a trigger and butt, as well as loosening to the metal components throughout. Dimensions: 75 cm x 12.75 cm x 9 cm (29.5" x 5" x 3.75")

Ownership may be restricted in some countries; see replica firearm notice in Buyer's Guide.

Contains electronics; see electronics notice in the Buyer's Guide.

**Estimate: £4,000 - 8,000**



**253**  
**Mega-City One Model**  
**Miniature Set**  
**Judge Dredd (1995)**

A Mega-City One model miniature set from Danny Cannon's Judge Dredd. After Fergie (Rob Schneider) was released from prison, he took a transport pod through Mega-City One to find his assigned residency which led him to the middle of a block war.

Judge Dredd received four nominations for Saturn Awards: Best Science Fiction Film, Best Special Effects, Best Costume, and Best Makeup.

Originating from a Mass. Illusions Visual Effects employee, this lot consists of eight pieces made of styrene and resin, detailed with kit-bashed model parts and cast greeblies, and painted industrial grey and blue. One of the buildings is equipped with wiring to illuminate the windows. This lot has undergone sympathetic restoration to readhere pieces that loosened or fell off over time, and it exhibits some scuffing and chipping throughout the finish. Any current functionality in the electronic elements remains untested. Dimensions: (largest) 61 cm x 48.5 cm x 35.75 cm (24" x 19" x 14").

Contains electronics; see electronics notice in the Buyer's Guide.

**Estimate: £4,000 - 8,000**

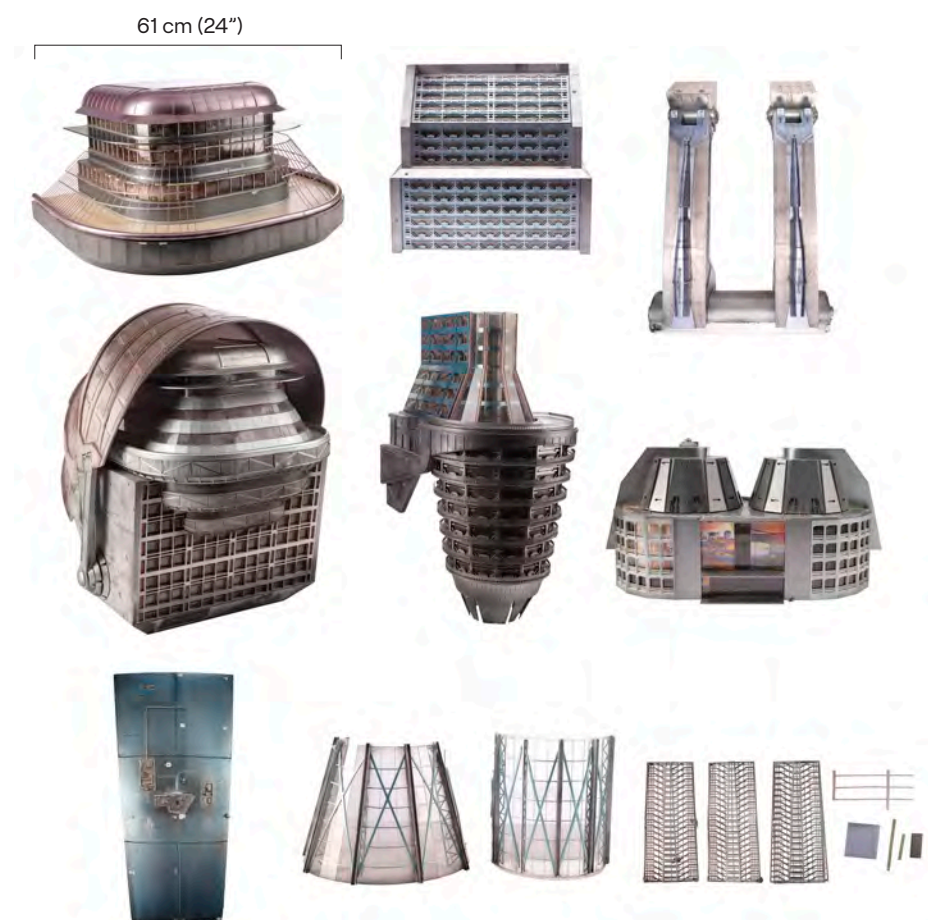



**254**  
**Jumanji Gameboard Faceplate**  $\Omega$   
**Jumanji (1995)**

A Jumanji gameboard faceplate from Joe Johnston's adventure comedy film Jumanji. Alan Parrish (Robin Williams), Sarah Whittle (Bonnie Hunt), Judy Shepherd (Kirsten Dunst), and Peter Shepherd (Bradley Pierce) played a mysterious but dangerous magic game called Jumanji which featured interactions with a real-life crazed hunter and dangerous creatures.

Jumanji was nominated for 11 awards with Bonnie Hunt winning a Saturn Award for Best Supporting Actress and Best Special Effects to Stan Parks, a Huabiao Film Award for Outstanding Translated Foreign Film, and a Young Artists Award for Best Family Feature Action-Adventure.

This lot consists of a painted resin faceplate featuring the word "Jumanji" in front of a scenic background including volcanoes, Acacia trees, shrubbery, and characters from the game and film, including a monkey, a rhinoceros, an elephant, and the crazed hunter Van Pelt (Jonathan Hyde) on the corners. This piece is intentionally distressed by production to appear aged and worn. It exhibits chipped paint and resin on the backing. Dimensions: 35.75 cm x 28 cm x 0.75 cm (14" x 11" x 0.25")

**Estimate: £7,000 - 14,000**

**255**  
**Jumanji Gameboard Rule Panels**  $\Omega$   
**Jumanji (1995)**

Jumanji gameboard rule panels from Joe Johnston's adventure comedy film Jumanji. Alan Parrish (Robin Williams), Sarah Whittle (Bonnie Hunt), Judy Shepherd (Kirsten Dunst), and Peter Shepherd (Bradley Pierce) played a mysterious but dangerous magic game called Jumanji which featured interactions with a real-life crazed hunter and dangerous creatures.

Jumanji was nominated for 11 awards with Bonnie Hunt winning a Saturn Award for Best Supporting Actress and Best Special Effects to Stan Parks, a Huabiao Film Award for Outstanding Translated Foreign Film, and a Young Artists Award for Best Family Feature Action-Adventure.

This lot consists of two wooden panels featuring the board game rules painted in black and red. These panels exhibit minor warping from age, holes, and deterioration on the backing. Dimensions: (each) 31.75 cm x 12.75 cm x 0.75 cm (12.5" x 5" x 0.25")

**Estimate: £4,000 - 8,000**



**256**  
**Test Cast Tokens**  $\Omega$   
**Jumanji (1995)**

A set of four test cast tokens from Joe Johnston's adventure comedy film Jumanji. Shoemaking heir Alan Parrish (Robin Williams) was sucked into the magical survivalist board game Jumanji and later freed by Peter Shepherd (Bradley Pierce), only to be forced to continue playing his game from 26 years before.

Jumanji was nominated for 11 awards with Bonnie Hunt winning a Saturn Award for Best Supporting Actress and Best Special Effects to Stan Parks, a Huabiao Film Award for Outstanding Translated Foreign Film, and a Young Artists Award for Best Family Feature Action-Adventure.

Differing in colour and texture from the final game pieces seen in the film, this lot consists of four resin game pieces cast in the shapes of a dark green elephant, a light green monkey, a dark grey rhinoceros, and a light brown crocodile. These pieces exhibit minor grime. Dimensions: (each) 7 cm x 2.75 cm x 3.25 cm (2.75" x 1" x 1.25")

**Estimate: £4,000 - 8,000**



**257**  
Italian Four-Foglio Poster m  
**La Dolce Vita (1960)**

A country-of-origin poster from the promotion of Federico Fellini's magnum opus *La Dolce Vita*. One of Fellini's multiple masterpieces, the film portrays a week in the life of tabloid journalist Marcello Rubini (Marcello Mastroianni) and his extra-marital affairs with an heiress (Anouk Aimee) and a Swedish movie star (Anita Ekberg). Frequently hailed as one of the greatest films ever made, *La Dolce Vita* has influenced some of cinema's finest directors including Martin Scorsese, who oversaw the restoration of this classic in 2010.

This highly sought-after poster, featuring artwork by Sandro Symeoni, rarely comes to auction. This example has been conservation linen-backed with some fold lines and scattered restoration to the top half, as well as a 30cm tear on the centre vertical fold from the top border. There has been restoration to the faces of the two women along the overlap of the two panels, as well as restoration to the whites on the lower panel. The title remains largely untouched but the Cineriz logo has had some work done to it. All restoration has been done to a high standard and the piece displays beautifully.  
Dimensions (paper only): 140 cm x 198 cm (55" x 78")

**Estimate: £8,000 - 16,000**



**258**  
The Costumi d'Arte Collection: Navarre's  
(Rutger Hauer) Knight Costume n  
**Ladyhawke (1985)**

Navarre's (Rutger Hauer) knight costume from Richard Donner's fantasy adventure *Ladyhawke*. Navarre wore his knightly attire while seeking out the Bishop (John Wood). This lot comes from the archives of the Italian costume company Costumi d'Arte.

The costume comprises a helmet, a hood, a doublet, a tunic, a cape and a pair of trousers. The helmet has a metal visor which is fixed in position by a screw. It is made of fibreglass, with a wooden lining, on which "63" is handwritten in black marker pen. Attached to the wood is a faux leather inner lining that is adjustable by string.

The doublet, tunic, cape, hood and trousers are all made of cotton. The doublet is sleeveless with stylish leather armhole rims, a mandarin collar and faux leather fastening straps with metal buckles. The tunic is fastened by a vertical Velcro strip and a cross lace. Navarre is the only character to wear this costume.

**Estimate: £5,000 - 10,000**



**259**  
The Costumi d'Arte Collection: Isabeau's (Michelle  
Pfeiffer) Final Scene Dress n  
**Ladyhawke (1985)**

Isabeau's (Michelle Pfeiffer) dress from the final scene of Richard Donner's fantasy adventure *Ladyhawke*. In the cathedral, Navarre (Rutger Hauer) refrained from killing the Bishop (John Wood) after Isabeau, whom he believed was dead, appeared in a lilac-coloured medieval dress. This lot comes from the archives of the Italian costume company Costumi d'Arte.

This full-length dress' airy and reflective qualities were intended to enhance Pfeiffer's almost ethereal appearance during the film's climax. It comprises an outer layer of chiffon and an inner layer of satin, and has slightly ribbed sleeves. A Peruzzi costume label is stitched into its interior.

**Estimate: £5,000 - 10,000**



**260**  
Complete Samurai Armour with Katsumoto Clan Flag and  
Stunt Katana m  
**The Last Samurai (2003)**

A complete set of samurai armour with a Katsumoto clan flag and a stunt katana from Edward Zwick's historical drama *The Last Samurai*. Samurai fighting under the command of Katsumoto (Ken Watanabe) wore armour during the film's various battle sequences. The armour comprises a do torso piece (labelled "Keiya Tabuchi Silk" in black marker), with sode shoulder guards (labelled "Taka Hero" in black marker) and a kusazuri skirt guard, all made of durable vinyl with incorporated cotton straps. It also features a spiked rubber helmet; a pair of cotton sleeves plated with rubber armour plating and chainmail (both labelled "Kenta 3" in black marker); a pair of rubber-plated cotton sunate shin guards; and a hard rubber chin guard (labelled "KHRS-4" in black marker). Keiya Tabuchi is a credited stunt performer on the production. The clothing components accompanying the armour comprise a brown jacket (labelled "Ikegam" and "a22" in black marker); a pair of matching trousers (labelled "Small" and "A4" in black marker); a red fabric sash belt; a rubber-padded cotton tunic (labelled "Katsumoto Clan" in black marker); and a pair of yellow straw sandals. The stunt katana has a resin hilt with a hard rubber guard. The blade and sheath are also made of hard rubber and are painted to look like metal and black leather, respectively. The flag is made of cotton and depicts the mystical tiger of the Katsumoto clan. Dimensions (katana in sheath): 98.5 cm x 9 cm x 7 cm (38.75" x 3.5" x 2.75")  
Edged, bladed or blunt object; see notice on Blades in the Buyer's Guide.

**Estimate: £3,000 - 6,000**

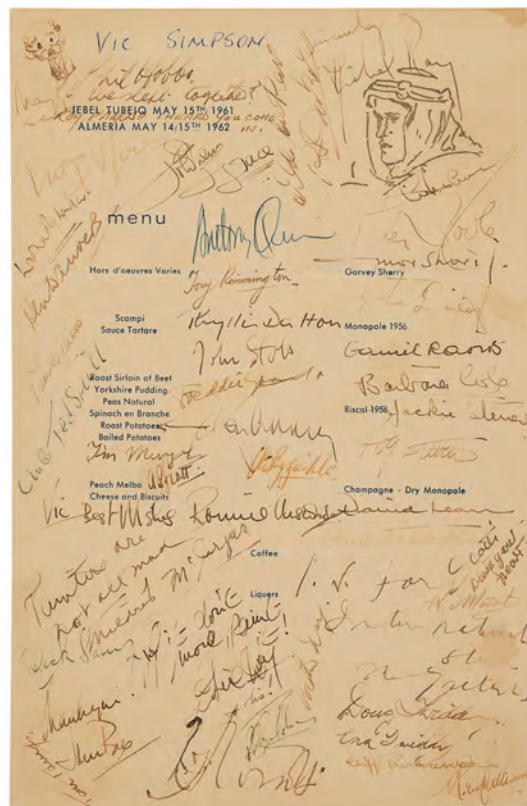

**261**  
David Lean, Peter O'Toole, Omar Sharif, and Key Cast and Crew-autographed One-Year Anniversary Menu m  
**Lawrence Of Arabia (1962)**

A cast autographed one year anniversary menu from the production of David Lean's epic biographical adventure film Lawrence of Arabia.

The menu has been autographed by 11 of the cast and crew, including Lean, Peter O'Toole, who played the titular character, Omar Sharif (Sherif Ali), and Anthony Quinn (Auda Abu Tayi). Also included are three behind-the-scenes photos and a journal published by the Society of Film and Television Arts which contains a number of interviews with key cast and crew members, including Lean and O'Toole. The menu exhibits some creasing. Dimensions: 28 cm x 19 cm (11" x 7.5")

The autographs in this lot have been professionally authenticated by expert Garry King; see notice in the Buyer's Guide.

**Estimate: £3,000 - 6,000**

57.25 cm (23")



53.5 cm (21")

**262**  
Lyle Conway Collection: Full-size Audrey II "Mean Green Mother" Puppet Head Leaf and Growing Plant Coffee Can Label with Conway-autographed Funko Pop! n  
**Little Shop Of Horrors (1986)**

A full-size Audrey II "Mean Green Mother" puppet head leaf and growing plant coffee can label from Frank Oz's Little Shop of Horrors with an Audrey II Funko Pop! autographed by Audrey II puppet creator Lyle Conway. Audrey II, a manipulative talking plant, quickly grew out of the coffee can Seymour Krelborn (Rick Moranis) stored her in by feeding on blood - first Seymour's, and eventually others'. This lot originates from the personal collection of Conway, a long-time collaborator of Oz's across several previous Jim Henson productions and, as head of the film's creature effects shop, the creator of Audrey II's ornate design. For his work on the film, Conway received an Academy Award® nomination for Best Visual Effects alongside Bran Ferren and Martin Gutteridge. Conway's team constructed six sizes of puppet - each with a different production nickname referencing its scale - to reflect the flesh-eating plant's growth, with a combination of humans and animatronics used to make her move and speak. This lot consists of one large vacuum-formed plastic leaf created for and used on the second-largest of the puppets, nicknamed "Supper-time," as well as for the head of the largest puppet, aka "Mean Green Mother." The leaf features a metal "spine" on its underside for structure, all of which is hand-painted green with purple splotches and textured with leafy veins to appear organic. Also included is a back-up wraparound coffee can label hand-made by the Pinewood Studios sign department by air-brushing and hand-painting Maxwell House Coffee logos onto a silk-screened blue rubber skin. The label was designed to expand and distort as Audrey II outgrew the can, with pneumatic rams used to push the can's sides outward. For their groundbreaking work, Conway gave each member of the sign department a bottle of Dom Perignon. Further, the lot includes an unopened Audrey II Funko Pop! Numbered "654," signed on its window in green ink by Conway and placed inside a clear plastic case. The leaf exhibits some fractures and discolouration along its edges, while the label exhibits stickiness and minor warping from age. Dimensions: (largest) 58.5 cm x 33 cm x 7.75 cm (23" x 13" x 3")

**Estimate: £1,500 - 3,000**



**263**  
Collection of Limited Edition Licensed Collectibles m  
**The Lord Of The Rings Trilogy (2001-2003)**

A collection of limited edition collectibles from the promotion of Peter Jackson's epic fantasy trilogy The Lord of the Rings.

This lot includes several Sideshow Weta polystone models: King Theoden; an Uruk-hai berserker; Aragorn; Sauron; Helm's Deep; a Fell Beast ridden by the Witch King of Angmar; the Argonath river statues; and the Witch King without his mount. Each was made by Sideshow Collectibles in collaboration with Weta Workshop.

Also included are a number of United Cutlery replicas: the Shards of Narsil; Anduril; Sting, with a leather scabbard; Sauron's helmet and gauntlet, wearing the One Ring; Gimli's helmet; a Gondorian Infantry helmet; and a High-elven helmet. Each of the United Cutlery replicas is lifesize, with the exception of the Sauron helm, which is half-scale. They are all made of metal and fibreglass-reinforced resin, and the helmets are leather-lined and come with a display stand. Each item comes with a certificate of authenticity.

All of the items in this lot are limited edition. With the exception of the Argonath statues, all retain their original packaging. Dimensions (Anduril): 135 cm x 5 cm x 15 cm (53" x 2" x 6")

Special shipping required; see special shipping notice in the Buyer's Guide.

**Estimate: £5,000 - 10,000**

**264**  
Legolas' (Orlando Bloom)  
Pair of Prosthetic Elf Ear Tips n  
**The Lord Of The Rings Trilogy (2001-2003)**

Legolas' (Orlando Bloom) prosthetic elf ear tips from Peter Jackson's epic fantasy trilogy The Lord of the Rings. Bloom wore his elf ear tips throughout his performance as Legolas, from his first appearance at the Council of Elrond in The Fellowship of the Ring to the trilogy's moving conclusion in The Return of the King.

These prosthetic pointed ear tips were an essential part of Legolas' elven appearance. Several pairs were created for Bloom by Weta Workshop during the massive production, which required multiple versions of each costume and make-up appliance. The ear tips' colour and shape was designed to suit the actor's complexion. Each is worn from production use and exhibits some cracking due to age.

The lot comes with a custom wood-and-metal stand, as well as a letter of authenticity from the actor's mother Sonia Bloom. Dimensions: 14 cm x 10 cm x 10 cm (5.5" x 4" x 4")

**Estimate: £3,000 - 6,000**



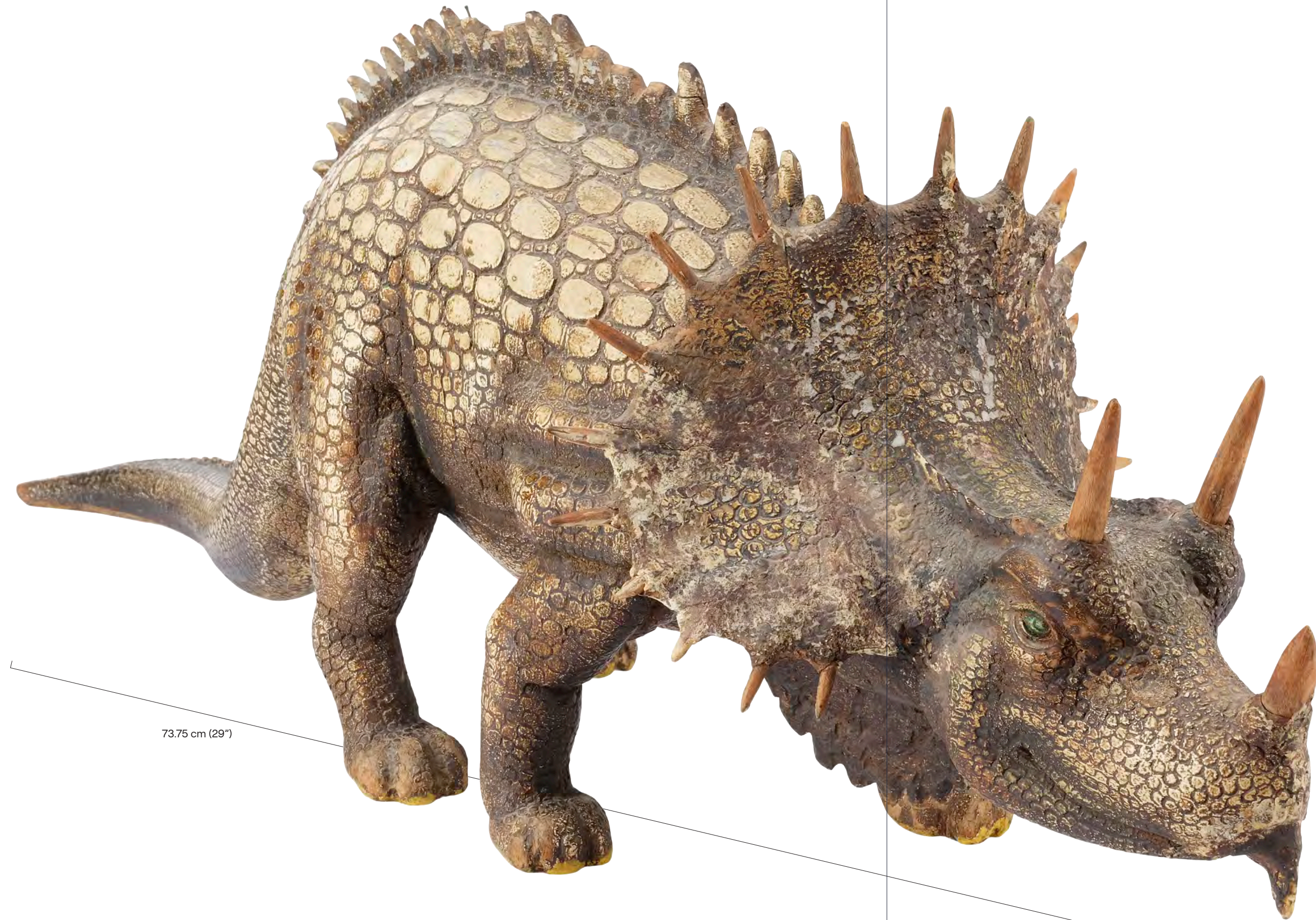

73.75 cm (29")

**265**  
**Stop-motion Agathaumas Stand-in Model**  
**The Lost World (1925)/King Kong (1933)**

A stand-in model believed to be from the production of Merian C. Cooper's and Ernest B. Schoedsack's King Kong based on the Agathaumas stop-motion puppet from Harry O. Hoyt's The Lost World. In The Lost World, an Agathaumas defended itself from an attacking Allosaurus before ultimately being killed by a Tyrannosaurus.

The Lost World featured groundbreaking stop-motion effects by animation pioneer Willis O'Brien, who would later gain fame for his stop-motion effects in King Kong. For both films, O'Brien designed the skeletal armatures over which Marcel Delgado built the puppets. During the production of King Kong, RKO's resident sculptor, John Cerasoli, carved static wooden models of each puppet that served as stand-ins during setup and test shots because the intense lighting on the stop-motion stages dried out the latex skin of the puppets and hindered their ability to be physically manipulated between frames.

Some materials from The Lost World, as well as the unfinished film Creation, were reused by O'Brien during the production of King Kong. While the design of this Agathaumas is that of the Agamauthus from The Lost World and was likely created based on that puppet, it is a wooden stand-in model, which implies that it was created during the production of King Kong, though it ultimately did not appear in the film's final cut. Puppets and models from King Kong, Son of Kong, Creation, and The Lost World were later used as set dressing in subsequent RKO pictures, often in scenes depicting museums or research labs. One such model, an Agathaumas, appeared in Alexander Hall's Once Upon a Time in 1944.

This intricately detailed, hand-carved wooden Agathaumas features a brown and black finish as well as holes in the feet, likely used for stage tie-downs or during the creation of moulds of the model. It exhibits chipping and paint wear from use and age as well as some missing spikes. Dimensions: 73.75 cm x 21.75 cm x 25.5 cm (29" x 8.5" x 10")

**Estimate: £32,000 - 64,000**



Holes in the feet likely used for stage tie-downs or during the creation of moulds of the model.



**266**  
 Max Rockatansky's (Tom Hardy)  
 Screen-matched Hero Muzzle  $\Omega$   
**Mad Max: Fury Road (2015)**

Max Rockatansky's (Tom Hardy) screen-matched hero muzzle from George Miller's dystopian action sequel Mad Max: Fury Road. Max was fitted with a muzzle after his capture by Immortan Joe's (Hugh Keays-Byrne) War Boys. He wore it while strapped to the front of Nux's (Nicholas Hoult) car and was only able to remove it once he joined up with Furiosa (Charlize Theron) on the War Rig. Its distinct markings and imperfections screen-match it to the scene just before Max and Furiosa fight by the War Rig.

Many of the props in Fury Road were created from 'found objects', so the muzzle is a repurposed garden hand fork. It is made of steel and intentionally distressed to look weathered. It features some foam padding at the back of the head to decrease discomfort, and comes on a custom-made display.

The lot is accompanied by two copies of a revised script page dated "5/10/2012", a collection of locks and keys, and nine behind-the-scenes photos, three of which feature Hardy, five feature Richard Carter (The Bullet Farmer), and one features an Imperator.

**Estimate: £15,000 - 30,000**



Maximum Film / Alamy Stock Photo



**267**  
 Max Rockatansky's (Tom Hardy) Stunt Shotgun  $\Omega$   
**Mad Max: Fury Road (2015)**

Max Rockatansky's (Tom Hardy) stunt shotgun from George Miller's dystopian action sequel Mad Max: Fury Road. Max found the shotgun in the wreckage of Nux's (Nicholas Hoult) car after they crashed in the sandstorm. He attempted to use it to free himself from his chains but the weapon misfired. Furiosa (Charlize Theron) later fought Max for control of the weapon, thinking it still worked.

This stunt shotgun is made primarily of hard rubber and is painted to look like wood and metal.  
 Dimensions: 48.5 cm x 5.5 cm x 10 cm (19" x 2.25" x 4")

Restricted ownership; see replica firearm notice in the Buyer's Guide.

**Estimate: £5,000 - 10,000**





**268**  
 "Peasant Sitting" Portrait by Milton Greene †  
**Marilyn Monroe**

A portrait of Marilyn Monroe from photographer Milton Greene's "Peasant Sitting" series. Greene wanted to showcase Monroe's ability as a dramatic actress and, while walking through the 20th Century Fox studio backlot with the actress, came up with the idea of her posing as a peasant. Monroe donned the costume worn by Jennifer Jones in her Oscar-winning performance in *The Song of Bernadette* (1943), while the French village set from *What Price Glory* (1952) was used as the backdrop. The photo series was shot on 24 May 1954.

This large-format photo is printed on Hahnemuhle Albrecht Durer paper and features Greene's printed signature in the bottom right corner. The copyright stamp of the Milton H. Green Archives Inc. is present on the reverse, along with the handwritten date "2007". The official print ID ("993, EX3"), printing date ("3/14/03") and the signature of the estate manager ("Joshua Greene") are all written in pencil on the reverse. The print has been rolled for storage. Display: 109 cm x 109 cm (43" x 43")

Sold without copyright; see copyright notice in the Buyer's Guide.

**Estimate: £4,000 - 8,000**

**269**  
 "Marilyn Monroe in Black Dior Dress"  
 Pigment Print by Bert Stern †  
**Marilyn Monroe**

A "Marilyn Monroe in Black Dior Dress" pigment print by photographer Bert Stern. Stern was born in New York City and worked as the art director for *Mayfair* magazine. During a long and illustrious career he photographed many iconic celebrities, including Audrey Hepburn, Elizabeth Taylor, Madonna and Kylie Minogue.

This archival pigment print shows Monroe posing in a black Dior dress, and was taken as part of Stern's series "The Last Sitting", created for *Vogue* in 1962. The photoshoot - which took place over three days at the Bel Air Hotel in Los Angeles, just six weeks before Monroe's passing - resulted in 2,500 photographs of Monroe.

Stern has signed and numbered the print ("15/72") in white crayon, along with the inscription "Marilyn." He has also included his signature and copyright (2011) in red crayon and applied his official stamp. Dimensions (framed): 77 cm x 68 cm x 3 cm (30.5" x 26.75" x 1.25")

Sold without copyright; see copyright notice in the Buyer's Guide.

**Estimate: £5,000 - 10,000**

**270**  
 "Marilyn Monroe as Jackie Kennedy"  
 Photographic Proof Sheet by Bert Stern †  
**Marilyn Monroe**

A four-way proof sheet of Marilyn Monroe posing as Jackie Kennedy by photographer Bert Stern. Stern was born in New York City and worked as the art director for *Mayfair* magazine. During his career he photographed many celebrities, including Audrey Hepburn, Elizabeth Taylor, Madonna and Kylie Minogue.

This framed C-print comprises four shots from a collection of 19 transparencies that went missing shortly after the photoshoot in June 1962 and were only rediscovered in recent years. Monroe is styled like Jackie Kennedy, wife of President John F. Kennedy, but considering Monroe's widely rumoured affair with the President, it was probably for the best that they were not published at the time.

Stern has signed the bottom right corner in white ink, and the print is labelled "8/50" in the bottom left corner. Dimensions (framed): 97 cm x 94 cm x 3 cm (38" x 37" x 1.25")

Sold without copyright; see copyright notice in the Buyer's Guide.

**Estimate: £3,000 - 6,000**



**271**  
 "With Rose" Photograph by Cecil Beaton †  
**Marilyn Monroe**

A photograph of Marilyn Monroe by photographer Cecil Beaton. Beaton was a British fashion, portrait and war photographer who worked for *Vogue* and *Vanity Fair*, and was the favoured photographer of the British Royal Family.

This framed black-and-white image of Monroe features her lying down in a white dress, clutching a rose to her chest. It was shot in 1956 at the Ambassador Hotel in New York, and Monroe once commented to Joshua Logan, her director on *Bus Stop*, that it was her favourite image of herself. It was the only photoshoot Beaton did with Monroe.

This lot originated from The Lost Archives of Marilyn Monroe, an auction hosted by Julien's on 5 and 6 December 2014, and was one of over 200 personal items of Monroe's sold there. Dimensions (framed): 64 cm x 59 cm x 3 cm (25" x 23" x 1.25")

Sold without copyright; see copyright notice in the Buyer's Guide.

**Estimate: £3,000 - 6,000**

**272**  
 "Marilyn Monroe in Repose" Extra Large Photograph  
 by Bernard of Hollywood †  
**Marilyn Monroe**

An extra-large format "Marilyn Monroe in Repose" portrait by photographer Bruno Bernard, aka Bernard of Hollywood. Bernard is credited with popularising pin-up photography, and first photographed Monroe in 1947, when she was still named Norma Jeane.

The framed image shows Monroe relaxing in the 20th Century Fox screening room while wearing her dress and heels from *The Seven Year Itch*. This dress featured prominently in arguably Monroe's most iconic image: standing over a subway grate with her white dress billowing up around her legs.

The photograph is numbered "5/50" and signed in the lower margin by the estate of Bernard, from which this lot originated. Dimensions (frame): 102 cm x 122 cm x 3 cm (40" x 48" x 1.25")

Sold without copyright; see copyright notice in the Buyer's Guide.

Special shipping required; see special shipping notice in the Buyer's Guide.

**Estimate: £3,000 - 6,000**

**273**  
 "In Sweater, Close Up" Photograph by George Barris †  
**Marilyn Monroe**

A chromogenic print of Marilyn Monroe by photographer George Barris. Barris was famous for his work with Monroe, whom he photographed on the set of *The Seven Year Itch*, before producing a collection of photos which have come to be known as "The Last Shoot", as they were shot shortly before Monroe passed away.

The photo was taken on Santa Monica beach and shows Monroe lying on the sand wrapped in a thick knit sweater. This framed print was produced and signed by Barris in 1987. "A.P." is handwritten in ink on the Barris copyright credit stamp on the reverse and was officially published by Marilyn Monroe/West Editions, Ltd. The photo has several tiny pinholes along the upper left edge. Dimensions (framed): 61 cm x 66 cm x 2.5 cm (24.5" x 26" x 1")

Sold without copyright; see copyright notice in the Buyer's Guide.

**Estimate: £2,500 - 5,000**





**274**  
 Stop-motion Martian Puppet m  
**Mars Attacks! (1996)**

A stop-motion Martian puppet from the production of Tim Burton's sci-fi comedy Mars Attacks! Based on the Topps trading card series, the film saw Martian invaders terrorising humanity during their conquest of Earth.

Burton's initial idea was to use stop-motion animation for the Martians, and several detailed puppets were constructed. However, stop-motion proved too complex, causing the movie's budget to escalate, and Burton was convinced to use CG animation created by ILM instead. The puppets were ultimately scanned and used as a primary reference for the final digital animation.

The puppet comprises an internal metal armature covered in foam latex skin, with an airbrushed green-and-brown finish. White acrylic eyes with red pupils and teeth adorn the face. The foam latex exhibits very minor deterioration, small patches of paint wear, and minor cracking above the eyes. Considering its age, the puppet remains in excellent overall condition, but care should be taken when handling due to its fragile nature. The lot is accompanied by a Warner Bros. certificate of authenticity. Dimensions: 38 cm x 15 cm x 6.5 cm (15" x 6" x 2.5")

**Estimate: £15,000 - 30,000**

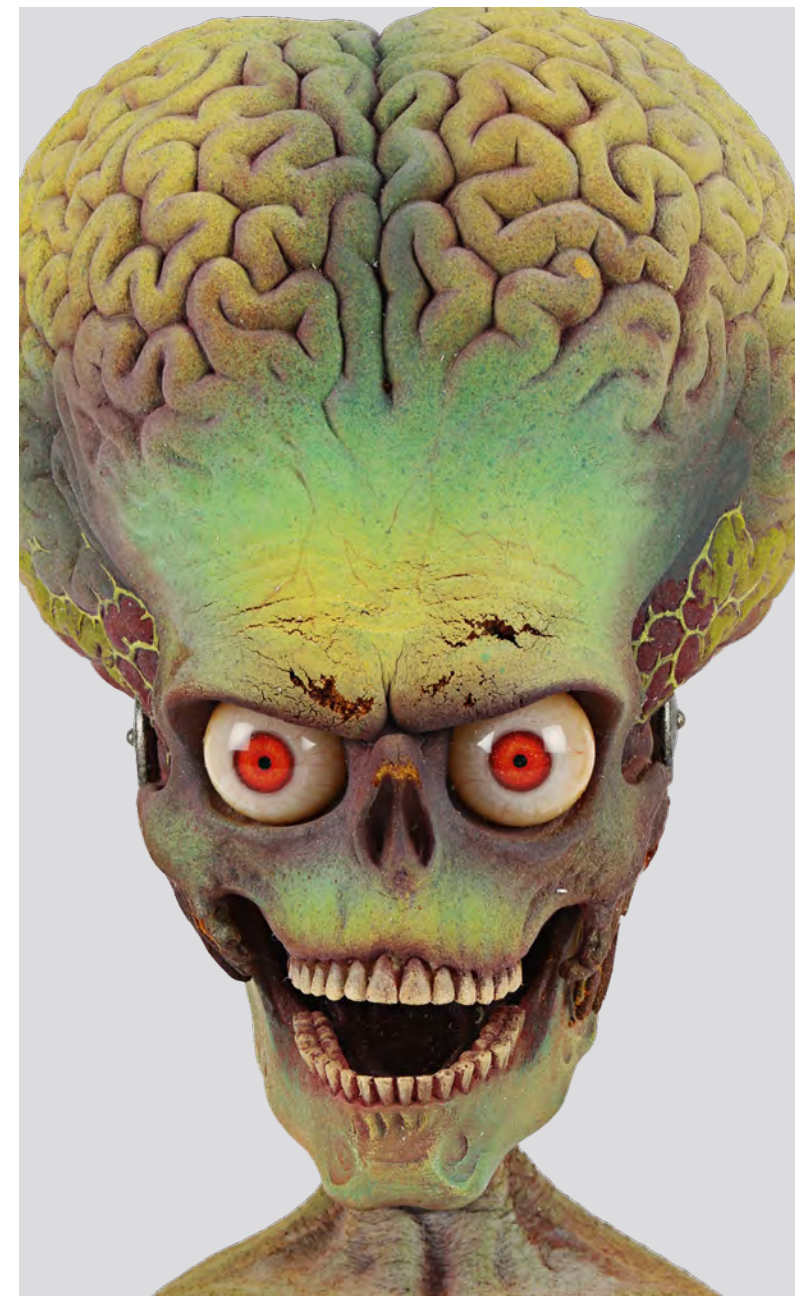

**275**  
 Major Rick Martinez's (Michael Pena) Martian Surface Suit t+d  
**The Martian (2015)**

Major Rick Martinez's (Michael Pena) Martian surface suit from Ridley Scott's sci-fi drama The Martian. Martinez and the other members of the Ares III crew wore their suits on the surface of Mars as a storm began to kick up, leading them to abort their mission.

Costume designer Janty Yates worked extensively with NASA officials, researchers and engineers to ensure the film's spacesuits were as realistic as possible.

The costume comprises a custom-made orange, white and black neoprene jumpsuit, a rubber neck piece, a pair of boots, and a skull cap. "Martinez Stunt" is handwritten inside the neck piece in white ink, while "M" is handwritten inside the skullcap in blue ink.

The boots comprise a pair of 5mm Celliant Infrared diving boots with a separately sourced outer boot frame made of rubber with a resin decorative feature on the top. Several detailed metal and resin components decorate the suit, including knee and shoulder pads. The costume is displayed on a custom-made mannequin and stand.

Special shipping required; see special shipping notice in the Buyer's Guide.

**Estimate: £5,000 - 10,000**



**276**  
 Light-up Hydra Heavy Assault Rifle m  
**Captain America: The First Avenger (2011)**

A light-up Hydra weapon from Joe Johnston's superhero film Captain America: The First Avenger. Hydra soldiers used their weapons to defend against raids on their bases by Steve Rogers (Chris Evans) and his team.

The weapon is made of foam, resin, metal and plastic. It still retains its original wiring, some of which is visible through a clear plastic screen on one side, where the light shines through. The light-up effect is also visible through the barrel of the weapon. Dimensions: 73 cm x 35 cm x 25 cm (29" x 14" x 10")

Contains electronics; see electronics notice in the Buyer's Guide.

**Estimate: £5,000 - 10,000**



**277**  
 Doctor Strange's (Benedict Cumberbatch) Hero and Stunt Sling Rings †Δ  
**Doctor Strange (2016)**

Doctor Strange's (Benedict Cumberbatch) hero and stunt sling rings from Scott Derrickson's superhero film Doctor Strange. Strange used his sling ring to create magical portals and travel around the world.

On its release, Doctor Strange was the most successful single-character Marvel Studios movie to date and garnered strong reviews. Cumberbatch's performance as the arrogant surgeon-turned-sorcerer received particular praise, the British actor having previously impressed in the title role of the popular BBC series Sherlock. To date, Cumberbatch has been nominated for two Academy Awards, for The Imitation Game and The Power of the Dog.

The hero ring is made of metal, while the stunt ring is rubber. Dimensions (hero ring): 7.75 cm x 2 cm x 3.5 cm (3" x 0.75" x 1.5")

**Estimate: £5,000 - 10,000**



**278**  
 Doctor Strange's (Benedict Cumberbatch) Hero Sling Ring and Pair of Stunt Sling Rings †Δ  
**Doctor Strange In The Multiverse Of Madness (2022)**

Doctor Strange's (Benedict Cumberbatch) sling rings from Sam Raimi's superhero sequel Doctor Strange in the Multiverse of Madness. Sling rings were mystical two-finger rings which granted Strange and his fellow wizards the ability to create inter-dimensional portals.

The lot comprises one hero ring, made of metal with intricate carvings, and two stunt rings, made of gold-painted rubber, with less detailed carvings. Dimensions: 7 cm x 5 cm x 4 cm (2.75" x 2" x 1.5")

**Estimate: £4,000 - 8,000**

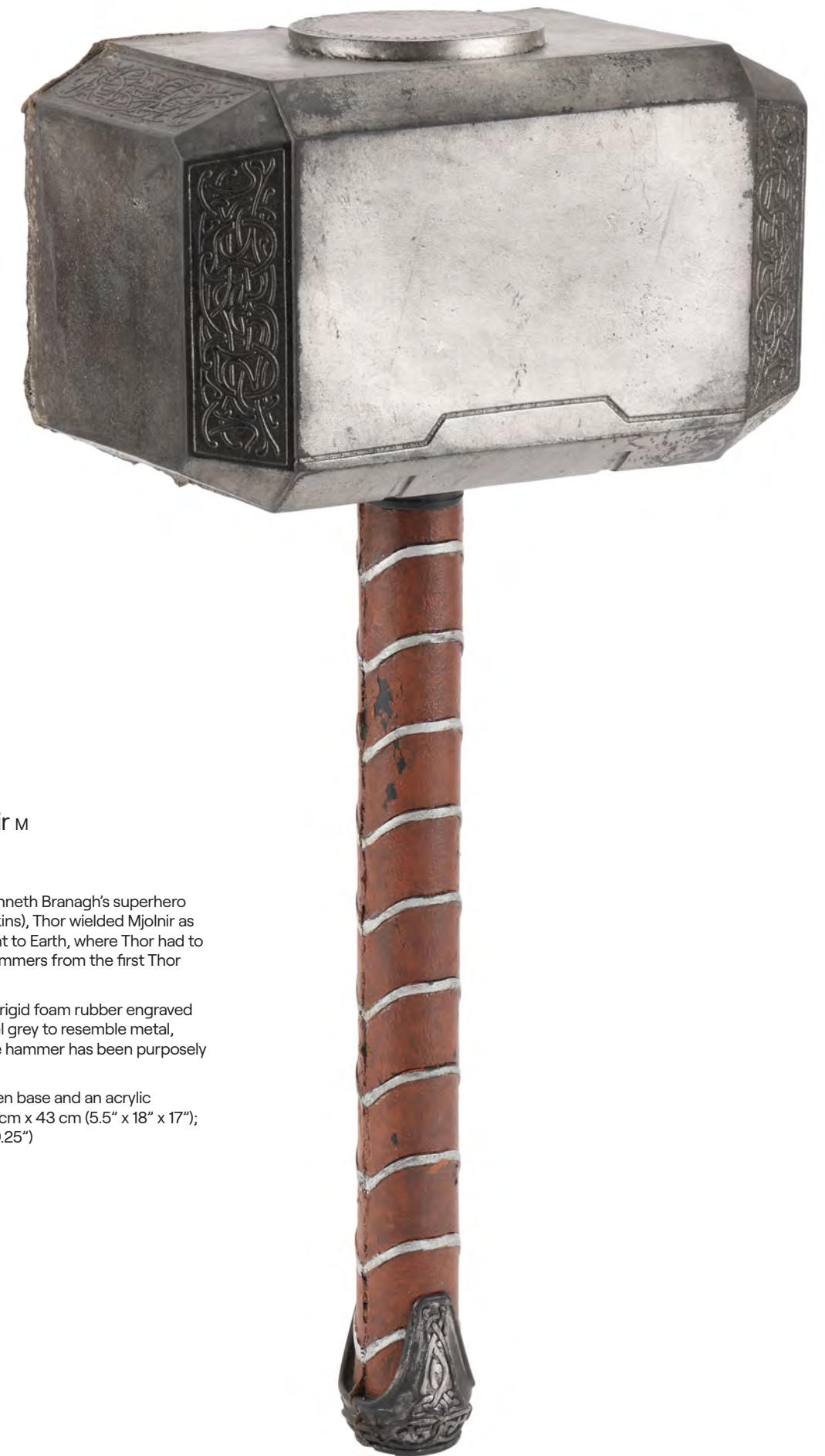

**279**  
 Thor's (Chris Hemsworth) Stunt Mjolnir †Δ  
**Thor (2011)**

Thor's (Chris Hemsworth) stunt Mjolnir hammer from Kenneth Branagh's superhero film Thor. Given to him by his father, Odin (Anthony Hopkins), Thor wielded Mjolnir as his signature weapon until it was taken from him and sent to Earth, where Thor had to prove himself worthy enough to wield it again. Mjolnir hammers from the first Thor film are rare.

This lightweight stunt hammer's head is made of dense, rigid foam rubber engraved with intricate Nordic designs and runes. It is painted steel grey to resemble metal, while its handle is brown with a silver-colour pattern. The hammer has been purposely distressed to appear well-used and battle-damaged.

It is accompanied by a display stand comprising a wooden base and an acrylic resting platform. Dimensions (on display): 14.25 cm x 46 cm x 43 cm (5.5" x 18" x 17"); (hammer): 14.5 cm x 23.25 cm x 49 cm (5.75" x 9.25" x 19.25")

**Estimate: £20,000 - 40,000**

**280**  
**Stand-in Groot Mask** †Δ  
**Guardians Of The Galaxy (2014)**

A stand-in Groot mask from the production of James Gunn's superhero sci-fi film Guardians of the Galaxy. The mask was worn on set by actor Krystian Godlewski, who also wore a motion capture suit to provide movement references for Groot's animators, while giving the other actors a physical presence to interact with.

The mask is made of resin, painted to look like wood with mossy details. Its interior features supportive rods joined by a thread of neon green string, to aid in mounting it atop Godlewski's head. Dimensions: 36 cm x 18 cm x 22 cm (14.25" x 7" x 8.75")

**Estimate: £5,000 - 10,000**



36 cm  
(14.25")



**281**  
**Lightning Gun** Ω  
**The Matrix Resurrections (2021)**

A lightning rifle from Lana Wachowski's The Matrix Resurrections. A rifle like this is seen in the flashback sequence from when Niobe (Jada Pinkett Smith) recounted the events of the civil war between the machines to Neo (Keanu Reeves).

Redesigned for Resurrections, this foam, resin, and metal high-tech rifle is smaller than its predecessors. It features integrated squid-like tubing, a smaller video tracker screen, and longer, thinner canisters around the body. It has a chrome-colour barrel, various tubing and wiring, and a black and grey finish applied throughout. It comes with a padded strap. It has undergone sympathetic restoration and exhibits chipped, flaked paint, a buildup of grime, discoloration, pitting in the resin, and adhesive residue. Dimensions: 61 cm x 23 cm x 28 cm (24" x 9" x 11")

Contains electronics; see electronics notice in the Buyer's Guide.

**Estimate: £5,000 - 10,000**



**282**  
**Sentinel Filming Model Miniature** Ω  
**The Matrix Reloaded (2003)/The Matrix Revolutions (2003)**

A sentinel reference model miniature from the production of the Wachowskis' The Matrix Reloaded and The Matrix Revolutions. After fighting to break into Zion in both films, hordes of sentinels fell from APU fire and a detonated EMP in Revolutions.

This squid-like sentinel originated from a crew member on both productions. Around eight total miniatures were created by the Miniature Unit for VFX and construction reference, then gifted to select crew following production. The sentinel features an ornately detailed cast resin head, plated tentacles inset with piping for structure, and jointed claws on its underside. It is painted metallic grey throughout to appear robotic and comes mounted near the head to a black display base inset with a plaque engraved "The Matrix Reloaded Revolutions."

This miniature exhibits scratching throughout its finish, some separation from the head and tentacles, and exposed metal from production use and age, while the base exhibits scuffing throughout. Dimensions: 71.25 cm x 20.5 cm x 20.5 cm (28" x 8" x 8")

**Estimate: £10,000 - 20,000**

**283**  
**Agent Smith's (Hugo Weaving) Stunt**  
**Desert Eagle and Sunglasses** M  
**The Matrix Reloaded (2003)/**  
**The Matrix Revolutions (2003)**



Agent Smith's (Hugo Weaving) stunt Desert Eagle and a pair of sunglasses from Lana and Lily Wachowski's sci-fi sequels The Matrix Reloaded and The Matrix Revolutions. Agent Smith and his clones wielded pistols and wore sunglasses throughout their appearances in the two films. They simultaneously fired their guns at Neo (Keanu Reeves) and his allies, with the latter only saved from harm by closing a heavy door at the last second.

The pistol is a Desert Eagle Mark XIX made of hard rubber. "R180" is handwritten in white marker pen on the bottom of the magazine. The sunglasses have acrylic lenses, plastic temples and temple tips. They have a missing temple on the right side, intentionally caused by the production during a fight scene. Dimensions (pistol): 27 cm x 4.25 cm x 15.5 cm (10.75" x 1.75" x 6")

Restricted ownership; see replica firearm notice in the Buyer's Guide.

**Estimate: £5,000 - 10,000**

**284**  
**Framed Clapperboard**   
**Monty Python's The Meaning Of Life (1983)**

A framed clapperboard from the production of Monty Python's *The Meaning of Life*. While the bulk of the feature was directed by regular Python director Terry Jones, the film opened with *The Crimson Permanent Assurance*, a short film conceived of and directed by fellow Python Terry Gilliam.

Often considered amongst the comedy group's crowning classics, *The Meaning of Life* received the Grand Jury Prize following its screening at the 1983 Cannes Film Festival. The following year, Jones, Michael Palin, Andre Jacquemin, and Dave Howman were nominated for a shared BAFTA® for their song "Every Sperm is Sacred."

This wooden clapperboard with a striped black-and-white slate and a metal hinge is applied with tape dated "12.11.82" and hand-labelled "The Meaning of Life," "Terry Gilliam/Roger Pratt," and take "D" on the front. The reverse is also applied with tape hand-labelled from previous slates, including one strip marked "A" and another marked "#1, 12-13," among other numbers.

The clapperboard comes mounted behind glass in a custom black frame above a promotional still from the film. It exhibits rusting on its hinge, fading and discolouration to the wood, and peeling to the tape from age. Dimensions: 49.5 cm x 62.25 cm x 7.75 cm (19.5" x 24.5" x 3")

**Estimate: £5,000 - 10,000**



LANDMARK MEDIA / Alamy Stock Photo

**285**  
**The Costumi d'Arte Collection:**  
**First Centurion's (John Cleese) Cuirass**   
**Monty Python's Life Of Brian (1979)**

The first centurion's (John Cleese) cuirass from Terry Jones' biblical comedy *Monty Python's Life of Brian*. The first centurion wore his cuirass in all his appearances, including during the beloved "Biggus Dickus" scene. This lot comes from the archives of the Italian costume company Costumi d'Arte. *Life of Brian* was Monty Python's most significant commercial and critical success. Beyond his work with the troupe, Cleese has had a hugely successful career, co-writing and starring in the classic British sitcom *Fawlty Towers*, and co-writing, co-directing and starring in the 1988 crime-comedy movie *A Fish Called Wanda*. The cuirass comprises two pieces of leather connected by buckled straps at the midriff and shoulders. Each piece is coloured dark burgundy, adorned with ornate metal symbols and details, and scalloped at the shoulders and waist. A label on the interior has "1612" handwritten on it in red marker pen. Also included are half-shell-patterned shoulder buckles not seen in the final cut. Additional Provenance: This lot comes from the archives of the famed Italian costume company Costumi d'Arte.

The company has been supplying some of the biggest film productions in the world with costumes for over 100 years

**Estimate: £10,000 - 20,000**



Cinematic / Alamy Stock Photo



**286**  
**Graham Chapman Military Jacket +**  
**Monty Python's**  
**The Meaning Of Life (1983)**

A Graham Chapman military jacket from Terry Jones' musical comedy *Monty Python's The Meaning of Life*. Chapman wore an elegant jacket while playing a military doctor in the First Anglo-Zulu War, who examined a soldier's missing leg, bitten off by a tiger which turned out to be two men in a costume. The *Meaning of Life* was the final feature film from the Monty Python troupe and was met with critical acclaim. Chapman was a beloved comedian who sadly passed away in 1989 at the age of 48, but not before leaving an indelible mark on both cinema and TV with his performances and writing. The jacket has a costume label sewn in its inside pocket on which Chapman's full name is printed. The garment exhibits discolouration on its collar and has some missing buttons on the shoulders.

**Estimate: £5,000 - 10,000**



**287**  
**Michael Palin Military Jacket +**  
**Monty Python's**  
**The Meaning Of Life (1983)**

A Michael Palin military jacket from Terry Jones' musical comedy *Monty Python's The Meaning of Life*. Palin wore an elegant jacket while playing a soldier in the First Anglo-Zulu War, whose comrade's leg was bitten off by a tiger that turned out to be two men in a costume. The *Meaning of Life* was the final feature film from the Monty Python troupe and was met with critical acclaim. Palin himself has had an illustrious career, both as part of Monty Python and individually. In 2013 he was awarded the BAFTA Fellowship, and in 2019 he was knighted by the late Queen Elizabeth. The jacket has a costume label sewn in its inside pocket on which Palin's full name is printed. The jacket exhibits a hole inside the collar.

**Estimate: £5,000 - 10,000**



**288**  
**John Cleese Military Jacket +**  
**Monty Python's**  
**The Meaning Of Life (1983)**

A John Cleese military jacket from Terry Jones' musical comedy *Monty Python's The Meaning of Life*. Cleese wore an elegant jacket while playing a soldier in the First Anglo-Zulu War, whose comrade's leg was bitten off by a tiger that turned out to be two men in a costume. The *Meaning of Life* was the final feature film from the Monty Python troupe and was met with critical acclaim. Even outside of Monty Python, Cleese has enjoyed a celebrated career. This includes co-writing and starring in the iconic British sitcom *Fawlty Towers*, and co-writing, co-directing and starring in 1988 crime comedy *A Fish Called Wanda*. The jacket has a costume label sewn to its inside pocket on which Cleese's full name is printed. There is also a handwritten "Lukasz Klimczak" costume label on the inside of the jacket, indicating it has since been used on another production. The garment exhibits missing shoulder buttons and straps.

**Estimate: £5,000 - 10,000**

228.75  
cm  
(90")



39 cm (15.25")

**289**  
Oversized Ninjetti Power Coin us  
**Mighty Morphin Power Rangers:**  
**The Movie (1995)**

An oversized Ninjetti Power Coin from Bryan Spicer's *Mighty Morphin' Power Rangers: The Movie*. After losing their powers following Ivan Ooze's (Paul Freeman) attack on the Command Center, the rangers were sent to the planet Phaedos, where Ninjetti animal spirits emitting from a colossal pyramid-mounted Power Coin granted the rangers the Great Power.

The film brought the popular Power Rangers franchise from television to the big screen, where it proved highly successful in the box office, its gross surpassing its budget in its opening weekend alone. The film also introduced the Ninja Ranger powers and Ninjazords, which would play a major role in the third season of the television series (albeit with a different origin story).

This oversized coin is made of resin-coated foam with a fibreglass reinforcement cast around metal mounts with loops for stabilisation. It is painted gold-colour and features highly detailed cast images of the Ninjetti animal spirits: Falcon, Crane, Frog, Ape, Wolf, and Bear. It exhibits paint flaking, extensive cracking, and missing resin panels exposing foam in some places. Dimensions: 228.75 cm x 228.75 cm x 38.25 cm (90" x 90" x 15")

Special shipping required; see notice in the Buyer's Guide.

**Estimate: £5,000 - 10,000**

**290**  
Hamunaptra Map m  
**The Mummy (1999)**

A Hamunaptra map from Stephen Sommers' fantasy adventure *The Mummy*. After stealing it from Rick O'Connell (Brendan Fraser), Jonathan Carnahan (John Hannah) presented a map to his sister and aspiring Egyptologist, Evelyn Carnahan (Rachel Weisz). The map led the explorers to Hamunaptra, the "City of the Dead", but it was later destroyed in a fire when the Medjai ambushed their boat.

The map features ancient Egyptian hieroglyphs, images of mythological gods, and significant landmarks that form the map, such as the River Nile. It has been printed on a piece of thin rectangular paper, intentionally stained and distressed to resemble ancient papyrus.

Dimensions: 39 cm x 27 cm (15.25" x 10.5")

**Estimate: £4,000 - 8,000**



**291**  
Imhotep's (Arnold Vosloo)  
Ritual Dagger m  
**The Mummy (1999)**

Imhotep's (Arnold Vosloo) ritual dagger from Stephen Sommers' action-adventure film *The Mummy*. Imhotep used his dagger as part of the ritual to revive Anck-su-namun (Patricia Velasquez).

The dagger is made of rubber painted faux gold, and has a blue hilt, which features a Pharaoh Hound decoration. The blade exhibits some paint damage, and the tip of the blade has broken off. Otherwise, the lot remains in good condition. Dimensions: 50 cm x 9 cm x 3 cm (19.75" x 3.5" x 1.25")

Edged, bladed or blunt object; see notice on Blades in the Buyer's Guide.

**Estimate: £3,000 - 6,000**



**292**  
The Scorpion King's  
(Dwayne Johnson) Hero Sword m  
**The Mummy Returns (2001)**

The Scorpion King's (Dwayne Johnson) hero sword from Stephen Sommers' action-adventure sequel *The Mummy Returns*. Imbued with the power of Anubis, the Scorpion King conquered all of Egypt before his soul was taken by the Egyptian god.

Made of cast brass, the sword features a curved blade with engraved scorpions and hieroglyphs, a woven grip, and a guard depicting two scorpions. Brown paint is applied as a shade to bring out the weapon's detailing. A ring mounted to the pommel once held a chain, part of which is still present. Dimensions: 88 cm x 17 cm x 4.5 cm (34.75" x 6.75" x 1.75")

Edged, bladed or blunt object; see notice on Blades in the Buyer's Guide.

**Estimate: £5,000 - 10,000**

93 cm  
(36.5")



**293**  
The Scorpion King's (Dwayne Johnson)  
Shield m  
**The Mummy Returns (2001)**

The Scorpion King's (Dwayne Johnson) shield from Stephen Sommers' action-adventure sequel *The Mummy Returns*. Imbued with the power of Anubis, the Scorpion King conquered all of Egypt before the god took his soul.

The shield is crafted from fibreglass resin, expertly painted with metallic paint to create the realistic appearance of metal, and features an intricate scorpion design. The tail of the scorpion curls out from the shield, and detaches from it by simply sliding out. The resulting vacant slot reveals "1" handwritten in green marker pen. The shield is further embellished on its reverse with decorative faux animal tails and faux leather holding straps. Dimensions: 93 cm x 45 cm x 31 cm (36.5" x 17.75" x 12.25")

**Estimate: £3,000 - 6,000**



**294**  
 Napoleon Bonaparte's  
 (Joaquin Phoenix) Hero  
 Sword and Scabbard †  
**Napoleon (2023)**

Napoleon Bonaparte's (Joaquin Phoenix) hero sword and scabbard from Ridley Scott's historical biopic Napoleon. Napoleon carried his sword into battle during his campaign of conquest.

This hero sword features a stainless steel blade, a faux-leather-wrapped grip, and a lion's head pommel. Much of the blade is blue with gold detailing, featuring lettering that reads "Chasseurs A Cheval Garde Imperiale," a light cavalry unit of the Imperial Guard. The scabbard is made of brass with two loops for attaching to the belt. Dimensions (sword in scabbard): 103 cm x 2.5 cm x 13 cm (40.5" x 1" x 5")

Edged, bladed or blunt object; see notice on Blades in the Buyer's Guide.

**Estimate: £5,000 - 10,000**



Lifestyle pictures / Alamy Stock Photo



**295**  
 Napoleon Bonaparte's  
 (Joaquin Phoenix)  
 Hero Dress Sword  
 and Scabbard †  
**Napoleon (2023)**

Napoleon Bonaparte's (Joaquin Phoenix) hero dress sword and scabbard from Ridley Scott's historical biopic Napoleon. The French emperor kept his dress sword sheathed at his waist for several formal scenes.

The sword has a straight steel blade, featuring blue colouring and decorative gold-colour emblems at the base. The hilt is also predominantly made of metal, except for its wooden grip. The accompanying scabbard is finished in leather, with metal features at either end, including an ornate guard. Dimensions (sword in scabbard): 100 cm x 5 cm x 11 cm (39.5" x 2" x 4.25")

Edged, bladed or blunt object; see notice on Blades in the Buyer's Guide.

**Estimate: £3,000 - 6,000**

51 cm  
 (20")



**296**  
 "Berserker" Stop-motion Puppet m  
**Nightbreed (1990)**

A "Berserker" stop-motion puppet from the production of Clive Barker's 1990 dark-fantasy horror film Nightbreed. The Berserker was just one of many creatures Lori (Anne Bobby) and Boone (Craig Sheffer) encountered while in the subterranean city of Midian. When the Sons of the Free initiated their pogrom on the Nightbreed, Boone released the Berserkers as a way to turn the tide.

The puppet is made of foam latex with faux hair and resin fingernails, and it features a machined-aluminium armature, complete with ball joints for moving and posing. The model comes with a custom-made display stand and remains in very good condition. However, due to its age and fragile nature, the armature should remain static. Dimensions (model): 51 cm x 18 cm x 20 cm (20" x 7" x 8")

**Estimate: £4,000 - 8,000**

38 cm  
 (15")

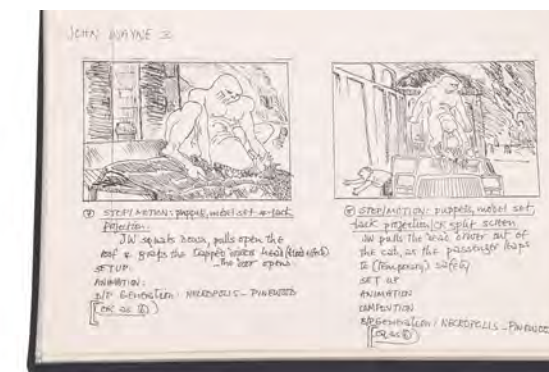

**297**  
 "John Wayne 2" Stop-motion Puppet  
 with Six Hand-drawn Storyboards m  
**Nightbreed (1990)**

An original "John Wayne 2" stop-motion creature puppet with drawings from the production of Clive Barker's 1990 dark-fantasy horror film Nightbreed.

The puppet was modelled in foam latex by creature-design artist Howard Swindell. It was part of a sequence that went to full dress test, but was ultimately not included in the final film. The puppet features a machined-aluminium armature, complete with ball joints to allow it to be moved and posed.

The lot comes with a custom-made display stand and seven production storyboard sheets, six of which are original pen-and-ink and depict the scenes in which the character was to appear. It also includes 14 A4 pencil concept drawings of the creature, which reveal its pre-production development. The model exhibits some damage to one hand and one foot, but otherwise remains in very good condition. However, due to its age and fragile nature, the armature should remain static. Dimensions (model): 38 cm x 23 cm x 23 cm (15" x 9" x 9")

**Estimate: £2,000 - 4,000**



22 cm (8.75")

**298**  
 "Leaper" Stop-motion Puppet and Paperwork m  
**Nightbreed (1990)**

A "Leaper" stop-motion puppet and paperwork from the production of Clive Barker's 1990 dark-fantasy horror film *Nightbreed*.

The Leaper was one of the many creatures Lori (Anne Bobby) and Boone (Craig Sheffer) encountered while in the subterranean city of Midian. Lori witnessed the Leaper eating a small furry creature.

The puppet is made of foam latex and has faux-hair whiskers protruding from the sides of its face, as well as a machined-aluminium armature, complete with ball joints for moving and posing. The lot comes with 14 production storyboard sheets showing the scenes in which it was to be used, plus four A4 pencil concept drawings and two production copies of the creature, revealing its pre-production development. The paint is flaking in a few places, but it otherwise remains in very good condition. However, due to its fragile nature and age, the armature should remain static. Dimensions (model): 22 cm x 9 cm x 28 cm (8.75" x 3.5" x 11")



Includes a binder of 14 production storyboards

**Estimate: £4,000 - 8,000**

**299**  
 Clapperboard n  
**Nightbreed (1990)**

A camera clapperboard from the production of Clive Barker's *Nightbreed*. Clapperboards such as this were used by camera crews to keep track of scenes, shots, and takes, as well as to sync sound.

This black wood clapperboard features black-and-white striped hinged clapper sticks on top; as well as "Prod. "Nightbreed," "Slate," and "Take" stencilled in white on the front. Additionally it features a hand-marked label for the date "22-5-89" and "Day - Int" on the front, and the back has "50 F.P.S." painted in white on black tape. It exhibits chipped paint, splintered wood, lifted adhesive, and discolouration. Dimensions: 20.75 cm x 16.5 cm x 1.5 cm (8.25" x 6.5" x 0.5")

**Estimate: £2,000 - 4,000**



LANDMARK MEDIA / Alamy Stock Photo

**300**  
 The Costumi d'Arte Collection: Frank's (Henry Fonda)  
 Screen-matched Suit n  
**Once Upon A Time In The West (1968)**

Frank's (Henry Fonda) screen-matched suit from Sergio Leone's epic spaghetti western *Once Upon a Time in the West*. The role of the sadistic villain Frank was a departure from the everyman hero roles Fonda was best known for. Frank wore his suit when he met Harmonica (Charles Bronson) in a saloon, and then when Harmonica saved Frank from being ambushed by his own men in the street. The suit screen matches through the placement of the pinstripe pattern on the jacket. This lot comes from the archives of the Italian costume company Costumi d'Arte and is part of their S.A.F.A.S collection as it was originally made by the tailoring house.

The costume comprises a black wool tailcoat with a white pinstripe pattern and an interior handwritten label reading "Fonda"; and a pair of black woollen trousers, also labelled "Fonda". Both pieces are size "50" and each has interior labels from Italian costume supplier Costumi d'Arte Peruzzi. This item is likely to have been rented to numerous productions over the decades since filming. Some minor modifications may have taken place during that time, including material around the jacket collar that appears to have been changed from leather to silk.

**Estimate: £25,000 - 50,000**







Photo 12 / Alamy Stock Photo

**301**  
 The Costumi d'Arte Collection: Jill McBain's (Claudia Cardinale) Costume  $\Omega$   
**Once Upon A Time In The West (1968)**

Jill McBain's (Claudia Cardinale) costume from Sergio Leone's epic spaghetti western *Once Upon a Time in the West*. McBain wore her costume as she arrived in Flagstone via train, expecting to meet her fiance at the station, but she later discovered he and his family had been murdered by Frank (Henry Fonda).

While not a huge hit at the time of its release, the film has gone on to become recognised as one of the greatest Westerns of all time.

This lot comes from the archives of the Italian costume company Costumi d'Arte and is part of their S.A.F.A.S collection as it was originally made by the tailoring house. The costume comprises a black long-sleeved bodice and a long black layered skirt. The bodice buttons up at the front and has an elasticated waistband, although this has stiffened. Both garments feature handwritten "C. Cardinale" labels and labels from Costumi d'Arte Peruzzi. This item is likely to have been rented to numerous productions over the decades since filming. Some minor modifications may have taken place during that time, including a change to the lace lining around the bodice neckline.

**Estimate: £15,000 - 30,000**



**302**  
 The Costumi d'Arte Collection:  
 Mr. Morton's (Gabriele Ferzetti) Screen-matched Robe  $\Omega$   
**Once Upon A Time In The West (1968)**

Mr. Morton's (Gabriele Ferzetti) screen-matched robe from Sergio Leone's epic spaghetti western *Once Upon a Time in the West*. Mr. Morton wore his robe while waiting on his train with the remainder of Frank's (Henry Fonda) men, having bribed some of them to kill Frank. It screen matches through its distinct patterning, most notably along the seams of the shoulders. This lot comes from the archives of the Italian costume company Costumi d'Arte and is part of their S.A.F.A.S collection as it was originally made by the tailoring house.

The robe is made from dark grey velvet with green, brown, ivory and mustard-coloured geometric patterns. It has a brown velvet lapel and belt, and a blank interior name label. It also has an interior label from Italian costume supplier Costumi d'Arte Peruzzi.

**Estimate: £10,000 - 20,000**



**303**  
 The Costumi d'Arte Collection:  
 Cheyenne's (Jason Robards) Shirt  $\Omega$   
**Once Upon A Time In The West (1968)**

Cheyenne's (Jason Robards) shirt from Sergio Leone's epic spaghetti western *Once Upon a Time in the West*. This lot comes from the archives of the Italian costume company Costumi d'Arte and is part of their S.A.F.A.S collection as it was originally made by the tailoring house.

Cheyenne wore his shirt for the middle section of the film, after he first arrived at Jill McBain's (Claudia Cardinale) ranch. The beige woollen shirt features a blue, grey and ivory striped pattern and a mandarin collar. There is a label in the collar, on which "Robards" is handwritten. This item is likely to have been rented to numerous productions over the decades since filming. Some minor modifications may have taken place during that time, including changing the shirt's buttons and altering the sleeve cuffs.

**Estimate: £10,000 - 20,000**



**304**  
The Costumi d'Arte Collection:  
Mr. Morton's (Gabriele Ferzetti) Coat and Trousers  
**Once Upon A Time In The West (1968)**

Mr. Morton's (Gabriele Ferzetti) coat and trousers from Sergio Leone's epic spaghetti western *Once Upon a Time in the West*. Morton wore his coat and trousers when he met with Frank (Henry Fonda), who knocked him to the ground and tried to intimidate him. Ferzetti had a long and distinguished career in Italian cinema and further afield, including the Bond film *On Her Majesty's Secret Service*, in which he played Marc Ange Draco.

This lot comes from the archives of the Italian costume company Costumi d'Arte and is part of their S.A.F.A.S collection as it was originally made by the tailoring house.

The long black double-breasted coat and black woollen trousers have handwritten "Ferzetti" labels, and each garment has interior labels from Costumi d'Arte Peruzzi.

**Estimate: £5,000 - 10,000**



**305**  
Suitcase, Baguette and Sandwiches  
**Paddington 2 (2017)**

A suitcase, baguette, and sandwiches from Paul King's comedy sequel *Paddington 2*. During the opening sequence, Paddington (voiced by Ben Whishaw) handed a wrapped marmalade sandwich to Mademoiselle Dubois (Marie-France Alvarez) as she gave him a lift on the back of her bike.

Each of these realistic marmalade sandwiches is made from two pieces of hand-painted cast foam rubber with orange-coloured silicone spread between them and adhering them together. One has had a metal bolt inserted into it, though this does not protrude on either side. The baguette is also made of foam rubber. The suitcase opens via two clasps, and has a sticker adhered to the top which reads "Wanted on Voyage", with a Smith-Englefield badge on the front. It comes with a set of keys. The case features some minor wear from production use, and the sandwiches exhibit some dirt. Dimensions: 41 cm x 26 cm x 11 cm (16.25" x 10.25" x 4.5")

**Estimate: £3,000 - 6,000**



**306**  
Paddington's Duffle Coat +  
**Paddington (2014)**

Paddington's (voiced by Ben Whishaw) duffle coat from Paul King's family comedy *Paddington*. Paddington's iconic blue duffle coat was given to him by the Brown family, having previously been worn by some of them. After this scene, Paddington's coat, like Paddington himself, was computer generated. This duffle coat was donated by Studio Canal to the international children's charity UNICEF UK.

The duffle coat has a hood and four wooden toggles up the front, with a plaid lining and an interior label from Academy Costumes.

All hammer price proceeds from this item will be donated to UNICEF UK. This lot is zero-rated for VAT purposes.

**Estimate: £2,500 - 5,000**



**307**  
The Reverend Mother's (Olivia Colman)  
Guitar and Rosary +  
**Paddington In Peru (2024)**

The Reverend Mother's (Olivia Colman) guitar and rosary from Dougal Wilson's comedy sequel *Paddington in Peru*. Paddington and the Brown family met The Reverend Mother in Peru while searching for Paddington's Aunt Lucy.

This wooden acoustic guitar was donated by Studio Canal to the international children's charity UNICEF UK. The guitar is accompanied by a multicoloured rosary made of felt and a padded guitar case with "Rev Mother 1" handwritten on a piece of tape adhered to the outside. Dimensions: 101 cm x 38 cm x 10 cm (39.75" x 15" x 4")

All hammer price proceeds from this item are being donated to UNICEF UK. This lot is zero-rated for VAT purposes.

**Estimate: £750 - 1,500**



UNICEF works in the world's toughest places to build a better world for every child, every day. A world where every child has the chance to fulfil their potential and grow up healthy and safe – from early childhood through adolescence. We make sure more of the world's children are vaccinated, educated and protected than any other organisation. We have done more to influence laws, policies and customs to help protect children than any other charity.



**308**  
Faun (Doug Jones) Face Appliance  $\pm$   
**Pan's Labyrinth (2006)**

A Faun (Doug Jones) face appliance from Guillermo del Toro's fantasy film Pan's Labyrinth. Upon arriving at the Labyrinth, Ofelia (Ivana Baquero) met the fantastical Faun, with whom she interacted throughout the film, as he entrusted her with three tasks. Pan's Labyrinth was both a commercial and critical success, winning three Academy Awards in 2007 for Best Cinematography, Best Art Direction and Best Make-up.

The Faun was brought to life using a combination of prosthetics created by DDT (founded by Academy Award-winners David Marti and Montse Ribe) and CGI, with Del Toro keen to avoid the complete use of digital effects to make the character more tangible.

The face appliance is made of latex, hand-painted green with faux hair attached at the chin and along each jawline. It is displayed on a stand comprising a wooden base and a fibreglass facial frame. Dimensions: 20 cm x 24 cm x 49 cm (7.75" x 9.5" x 19.25")

**Estimate: £7,500 - 15,000**

**309**  
Henri "Papillon" Charriere's (Steve McQueen)  
Prison Shirt  $m$   
**Papillon (1973)**

Henri "Papillon" Charriere's (Steve McQueen) prison shirt from Franklin J. Schaffner's prison drama Papillon. Papillon wore his shirt while he attempted to survive the harsh environment of Devil's Island prison.

This long-sleeved red-and-white-striped wool-blend shirt features a pair of buttons on the front as well as a small collar. Its overly long sleeves each feature a button-up cuff. One side of the interior features a red-and-white Western Costume Co. label marked for "Steve McQueen" along with the shirt's dimensions.

**Estimate: £6,000 - 12,000**

**310**  
Jim Preston's (Chris Pratt) Screen-matched  
Light-up Distressed Avalon Spacesuit  $\Omega$   
**Passengers (2016)**

Jim Preston's (Chris Pratt) screen-matched, light-up distressed Avalon spacesuit from Morten Tyldum's sci-fi film Passengers. After being awakened from suspended animation decades too soon onboard a spaceship, mechanical engineer Preston wore his suit while he attempted to repair the ship and save the lives of its passengers. Distressing on the cuirass matches to the scene following the repair of the reactor vent.

Passengers was nominated for two awards, at the 89th Academy Awards®, including Best Production Design, a category in which it was also nominated for a Saturn Award and won an Art Directors Guild Award. The unique designs for the film's space suits were created by award-winning French costume designer Jany Temime, who also designed the space suits for Alfonso Cuarón's Gravity.

This costume consists of a grey plastic, fibreglass, and metal helmet; a matching oxygen regulator chest and back piece marked "CHRIS PRATT BURNED" with electrical wiring in the interior and shoulder accent replicas fabricated based on the production original accents; a grey neoprene neckpiece with fastening strips, a grey polyester and neoprene jacket marked "CHRIS PRATT HERO #1" and matching trousers marked "CHRIS PRATT HERO #2" with rubber and metal accents containing wiring on the interior; a grey belt marked "CHARRED" with plastic and metal embellishments and fastening strips, a pair of gloves marked "C" with plastic and metal accents and wired interiors; and boots marked "X" with wired interiors.

The entire lot has been intentionally distressed with charring and scuff marks by production. Following production, wiring inset on the armour, jacket, trousers, gloves, and boots designed to activate lighting elements when plugged into a power source underwent sympathetic repair, as did the oxygen regulator. The suit exhibits additional signs of wear from use, including various scuffs and scratches.

Contains electronics; see electronics notice in the Buyer's Guide.

**Estimate: £15,000 - 30,000**



Homestead right arm patch



Illuminated gloves



Side of boots light-up red or green





**311**  
 Freddy Krueger's (Robert Englund) Sweater  $\alpha$   
**Wes Craven's New Nightmare (1994)**

Freddy Krueger's (Robert Englund) sweater from Wes Craven's horror thriller Wes Craven's New Nightmare. When a new film in Craven's "A Nightmare on Elm Street" horror franchise went into production, the cast and crew were terrorized by a metaphysical manifestation of the series' notorious villain, Freddy Krueger, who has made his way into the "real world".

In order to recreate the classic movie villain in a way which would make him less comedic and more distinct and intimidating for this film, Krueger was reimagined with a modified wardrobe. This variation of Krueger's classic wool sweater features an olive green and red horizontal striped pattern throughout with accents on the neck and wrists. It exhibits signs of wear throughout from age and use.

**Estimate: £10,000 - 20,000**

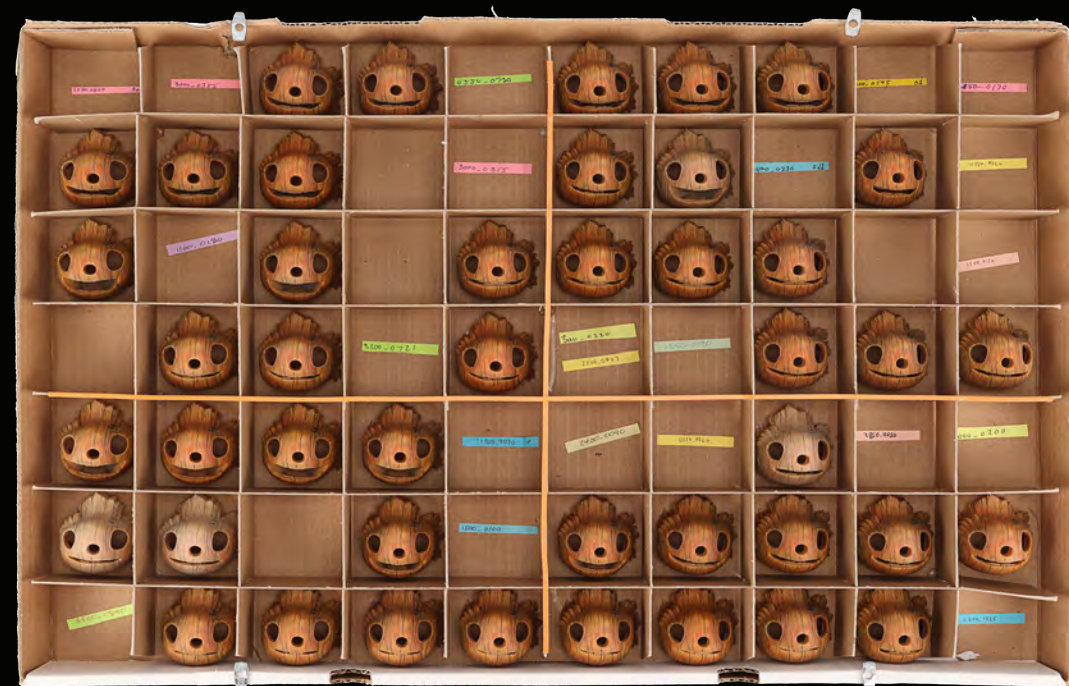

76.25 cm (30")



**312**  
 Set of Pinocchio (Gregory Mann)  
 Stop-Motion Heads in Display  $\dagger\Delta$   
**Pinocchio (2022)**

A display containing a set of Pinocchio (Gregory Mann) stop-motion heads from Guillermo del Toro and Mark Gustafson's Oscar-winning stop-motion musical adventure Pinocchio. The look of Del Toro and Gustafson's Pinocchio was inspired by the illustrations of Gris Grimley in a 2002 edition of Carlo Collodi's novel The Adventures of Pinocchio, on which the film is loosely based, despite its 1930s setting.

During the production, animation studio ShadowMachine 3D-printed approximately 3,000 Pinocchio heads, including over 800 of the wooden boy smiling, 50 of him yelling, and nine of him dead. Such a vast number were manufactured to sustain the process of replacement animation, which involves changing a puppet's head whenever its expression changes.

This set of heads remains in its original storage container, a pizza-style cardboard box displayed inside a vitrine. While some of the container's head spaces are vacant, they still feature handwritten labels indicating which type of head was to be placed there.

This set was displayed at New York's Museum of Modern Art for the "Guillermo Del Toro: Crafting Pinocchio" exhibition, which ran from 11 December 2022 to 15 April 2023. Dimensions: 76.25 cm x 57 cm x 9.25 cm (30" x 22.5" x 3.75")

**Estimate: £7,500 - 15,000**



**313**  
 Captain Jack Sparrow's (Johnny Depp) Tricorne  $m$   
**Pirates Of The Caribbean: At World's End (2007)**

Captain Jack Sparrow's (Johnny Depp) tricorne from Gore Verbinski's action-adventure sequel Pirates of the Caribbean: At World's End.

Jack wore his tricorne hat throughout the film as he escaped Davy Jones' (Bill Nighy) Locker, reunited with his dubious allies, and sought to defeat his enemies while re-acquiring his precious ship, The Black Pearl. Depp based his performance on rock legend Keith Richards, who appears in the film as Captain Teague, Jack's estranged father.

The tricorne is a key component of Captain Jack's iconic costume, created by Oscar winning costume designer Penny Rose. Depp worked closely with Rose and chose a leather tricorne to ensure Jack's hat remained distinct from those worn by the other characters in the film series.

The tricorne features a cross stitch in brown thread to maintain its shape, and has been intentionally distressed to appear weathered and aged. Its interior shows a label from Italian costumer Pieroni Bruno, on which "62" is handwritten in pen. Dimensions: 32 cm x 11.25 cm x 38 cm (12.5" x 4.5" x 15")



**Estimate: £10,000 - 20,000**



**314**  
 Set of Four Ex-Presidents Reference Copy Masks  $m$   
**Point Break (1991)**

Four Ex-Presidents reference copy masks from the production of Kathryn Bigelow's action thriller Point Break. The gang of bank robbers known as the Ex-Presidents wore masks representing Ronald Reagan, Richard Nixon, Lyndon B. Johnson and Jimmy Carter, respectively.

These dense rubber masks were made from the original moulds as reference casts by Academy Award®-winning special effects group Amalgamated Dynamics, Inc. Each features hand-painted skin, hair and teeth, tape on the inside, and punctures at the back for display purposes. The masks exhibit small tears from age and come presented on black velour-coated polystyrene stands. Dimensions (each): 41 cm x 25 cm x 25 cm (16.25" x 10" x 10")

**Estimate: £4,000 - 8,000**



LANDMARK MEDIA / Alamy Stock Photo

**315**  
The Dread Pirate Roberts' (Cary Elwes) Mask m  
The Princess Bride (1987)

The Dread Pirate Roberts' (Cary Elwes) mask from Rob Reiner's fantasy adventure comedy The Princess Bride. Former farmhand Westley wore his mask as he took on the guise of the Dread Pirate Roberts and rescued his love Princess Buttercup (Robin Wright) from Vizzini (Wallace Shawn) and his crew. Adapted from a book by William Goldman, The Princess Bride has become an incredibly popular film and regularly appears on lists of the funniest movies ever made.

The black leather mask is displayed on a custom-made stand. It has a Bermans & Nathans label on the inside, on which "#2 - Princess Bride" is handwritten in blue ink. Dimensions (on display): 23 cm x 16.5 cm x 25.5 cm (9" x 6.5" x 10")

**Estimate: £10,000 - 20,000**



**316**  
Count Rugen's (Christopher Guest) Screen-matched Machine Book m  
The Princess Bride (1987)

Count Rugen's (Christopher Guest) screen-matched Machine book from Rob Reiner's fantasy adventure comedy The Princess Bride. The 11-fingered Count Rugen filled in a book while torturing prisoners with "The Machine" in the Pit of Despair. The positioning of the handwriting on the first page and markings on the page edges screen-match this book to the one seen in the film.

The book has 80 pages in total, including 17 with handwriting and hand-drawn images of The Machine in use. It is bound between thick card covers decorated with colourful marbled patterns, and the pages are deckle-edged. The book has been intentionally distressed to look well used. Dimensions: 31 cm x 30.5 cm x 3.5 cm (12.25" x 12" x 1.5")

**Estimate: £6,000 - 12,000**

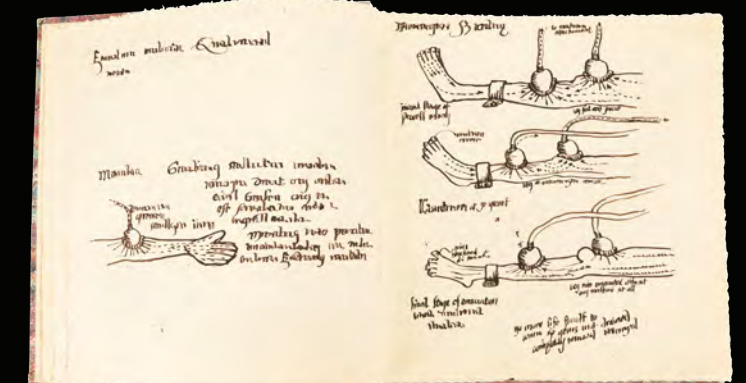
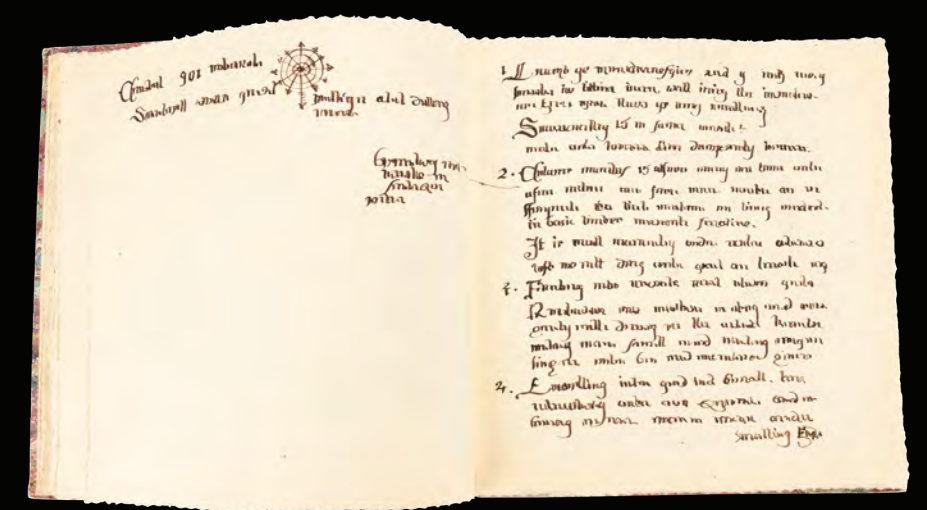



**317**  
Buttercup's (Robin Wright) Dress †  
**The Princess Bride (1987)**

Buttercup's (Robin Wright) dress from Rob Reiner's fairy-tale adventure The Princess Bride.

Buttercup wore her red dress when she was kidnapped by Vizzini (Wallace Shawn), Inigo (Mandy Patinkin) and Fezzik (Andre the Giant). She also wore it during her reunion with her true love Westley (Cary Elwes), and while traversing the deadly Fire Swamp.

This full-length dress is made from red cotton with a herringbone weave. It features puffy, laced-up sleeves, stitched, laced-up eyelets on the back, and a petticoat. The dress shows some wear from production use and age, with loose threads and plucked stitching, most notably on the inside, where some of the stitching has come away. There is also some fraying, and a few small dark stains.

**Estimate: £5,000 - 10,000**

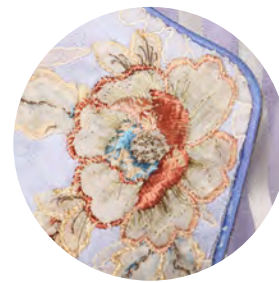

Embroidered lapel detail



**318**  
Olivia Wenscombe's (Scarlett Johansson)  
Screen-matched Dress †Δ  
**The Prestige (2006)**

Olivia Wenscombe's (Scarlett Johansson) screen-matched dress from Christopher Nolan's sci-fi mystery The Prestige. Olivia wore an elegant bodice and skirt combination in a restaurant with Alfred Borden (Christian Bale), where she left him after he revealed that he didn't love his wife. The bodice matches the one seen on screen through the floral patterns on the lapels.

The bodice is made from silk and features two costume labels. One has "Scarlett Johansson" handwritten on it in blue ink, and the other has "1876-7 KH00076" handwritten on it in black ink. The skirt is also made from silk and features two costume labels. "S. Johansson" is handwritten on one in black ink and "KH00076" is handwritten on the other, also in black ink. The costume also includes a cotton waistcoat and a baby blue bum pad.

**Estimate: £4,000 - 8,000**



Alister Picture Library Ltd / Alamy Stock Photo

**319**  
Andrew McCarthy Collection:  
Blane McDonnagh's  
(Andrew McCarthy)  
Screen-matched Jacket Ω  
**Pretty In Pink (1986)**

Blane McDonnagh's (Andrew McCarthy) screen-matched jacket from Howard Deutch's Pretty in Pink. Blane wore his signature jacket throughout the film - including when he watched Andie Walsh (Molly Ringwald) across the hall at school and later when he picked Andie up from Trax, the record store, for their first date - as well as in the iconic poster featuring McDonnagh, Walsh, and Philip "Duckie" Dale (Jon Cryer). An anomaly in the stitching on the right lapel and near the right sleeve's shoulder patch screen-matches to shots throughout the film.

Among the most influential films of the 1980s, Pretty in Pink quickly became a cult classic for its realistic and highly sympathetic depiction of modern teen life. For his role as McDonnagh, McCarthy is today known as one of the foremost members of the Brat Pack, a designation he investigated in his hit 2024 documentary Brats.

This Johnbalt jacket (Size M), which has been in McCarthy's personal collection since filming, is among the character's most distinctive costume pieces. Made from light brown polyester, it features one small and two large front pockets and tortoiseshell-patterned buttons on the chest and sleeves. The jacket exhibits staining along its left lapel and right side from wear.

**Estimate: £8,000 - 16,000**





**320**  
Hero Flamethrower  $\pm$   
**Prometheus (2012)**

A hero flamethrower from Ridley Scott's sci-fi prequel Prometheus. The crew of the Prometheus landed on the distant moon LV-223 seeking evidence of an alien culture. To the surprise of the crew's scientists, mercenaries on board the ship brought flamethrowers to the seemingly dead planet. These weapons were used by Vickers (Charlize Theron) on the infected Holloway (Logan Marshall-Green), and by Janek (Idris Elba) on the mutated Fifield (Sean Harris).

This once-functioning flamethrower was custom-built for the film and features two gas tanks within an open metal frame. There is a black plastic trigger handle mounted at the rear of the flamethrower, with orange-coloured triggers. A carry handle juts out from the weapon, allowing the user to support it during use. The larger of the two tanks is decorated with a "Weyland Enterprises" logo sticker on each side of the canister. A plaque attached to the frame lists the makers of the lot, and gives the flamethrower's name as "Derek". The flamethrower was decommissioned after use on the production. Dimensions: 95 cm x 22 cm x 38 cm (37.5" x 8.75" x 15")

**Estimate: £8,000 - 16,000**

**321**  
Light-Up Spacesuit Helmet  $\alpha$   
**Prometheus (2012)**

A light-up spacesuit helmet from Ridley Scott's sci-fi prequel Prometheus. The mechanics working in the USS Prometheus' hangar were wearing their helmeted spacesuits when they were attacked by the mutated Fifield (Sean Harris).

The critically-acclaimed science-fiction horror prequel to Scott's Alien franchise was the highest-grossing horror film of 2012 and remains the 11th highest-grossing horror film of all time. It was nominated for a number of awards, including the Academy Award® for Best Visual Effects.

This lot consists of a clear, globe-shaped acrylic helmet with switch-operated fans and lighting connected to wiring and batteries in the Weyland Corp-labelled neck and backpiece, fingerprint warning decals, and black and red nylon harnessing. The inside is labelled "Mechanic 1 #2." The helmet, neck, and back pieces exhibit scuffing, and some of the adhesive has come loose around the neck and internal electronics.

Contains electronics; see electronics notice in the Buyer's Guide.

**Estimate: £4,000 - 8,000**



"Weyland Corp" logo back detail



Ampule interior detail

43.5 cm (17.25")



**322**  
Hero Ampule  $m$   
**Prometheus (2012)**

A hero ampule from Ridley Scott's sci-fi prequel Prometheus. On the moon LV-223, the crew of The Prometheus found cavernous rooms filled with ampules, which extraterrestrial "Engineers" used to store terraforming biochemicals.

Raku pottery specialist Rob Sollis was recruited to craft the ampules, taking inspiration from Roman glass urns. This particular version is created from clay with alien text vertically etched into the ampule's gently curving body. The lot exhibits a loose piece of clay on the rim of the ampule's lower section, and there are signs of repair. Dimensions: 43.5 cm x 17.5 cm x 17.5 cm (17.25" x 7" x 7")

**Estimate: £3,000 - 6,000**

**324**  
Head Wheeler Stunt Wheels  $m$   
**Return To Oz (1985)**

A set of head Wheeler stunt wheel appliances from Walter Murch's dark fantasy sequel Return to Oz. The troublemaking Wheelers had wheels for hands and feet and terrorised Dorothy (Fairuza Balk) on the orders of the wicked witch Mombi (Jean Marsh). This set of Wheeler wheels originally belonged to stunt performer Colin Skeaping, who performed as one of the head wheelers alongside Pons Maar, and also notably featured as Luke Skywalker's (Mark Hamill) double in the Star Wars franchise.

The two front wheel appliances each comprise a rubber wheel with silver-painted plastic hubcaps attached to a black-painted metal frame designed to fit around the performer's arms. The frames have foam padding around the top, with plastic handle grips (one red and one blue) and a brake lever. "Colin" is written in black pen on the blue-handled frame.

The two back wheel appliances also feature rubber wheels, but these include a mechanism that only allows them to move forward. Their hubcaps are attached to a black-painted metal-and-plastic frame designed to fit around the performer's calves via webbing and clip closures at the top. The leg appliances also feature a pair of Rancor® high-top trainers (size 8), with "Colin" handwritten in blue pen on the back of each shoe. These are fastened with screws to the frame's base and a pair of grey woollen socks with the toes cut off. A hubcap is missing from the red-handled front wheel and the back-left wheel, and all the wheels exhibit significant paint wear, scratches and minor dents from production use. The brake on the red-handled front wheel is slightly stiff. Dimensions (front): 86.5 cm x 29 cm x 11.5 cm (34" x 11.5" x 4.5"); (back): 74 cm x 31 cm x 15.5 cm (29.25" x 12.25" x 6.25")

Contains mechanical components; see mechanical notice in the Buyer's Guide.

**Estimate: £5,000 - 10,000**



**323**  
SFX Dagger of Time, Stab Plate and Pair of Call Sheets  $m$   
**Prince Of Persia: The Sands Of Time (2010)**

An SFX Dagger of Time and stab plate from Mike Newell's fantasy action film Prince of Persia: The Sands of Time. Dastan (Jake Gyllenhaal) stabbed himself in the chest with the dagger to prove to his brother Tus (Richard Coyle) that it had the ability to reverse time.

The dagger is made of clear acrylic and solid resin painted to look like metal. It still retains some "sand" in the hilt. The stab plate is made of solid resin, and features fabric straps, with a protruding metal plate into which the SFX dagger slots, creating the illusion of a stab wound. For this purpose, the blade of the dagger is halved. The lot also includes two production call sheets. Dimensions (dagger): 29 cm x 14 cm x 5 cm (12" x 5.5" x 2")

**Estimate: £3,000 - 6,000**



Back wheel appliances

Front wheel appliances

**325**  
 Ace Rimmer's (Chris Barrie)  
 Light-up Miniature  
 "Dimension Jump" Ship M  
**Red Dwarf - Dimension Jump (1991)**

Ace Rimmer's (Chris Barrie) light-up "Dimension Jump" ship model miniature from the sci-fi comedy TV series Red Dwarf. This model was used in the fifth episode of the show's fourth series, titled "Dimension Jump." The ship sent Ace Rimmer to a parallel dimension where he met the crew of Red Dwarf and his cowardly alter ego Arnold Rimmer (Barrie).

The ship was built by Peter Wragg's model-making team and is made of resin and plastic components, with additional pieces from commercial model kits used for dressing. It is finished in the standard Space Corps red paint scheme and has a range of Space Corps markings across its fuselage. The halogen bulbs that were once present within the engines have been removed and replaced with LEDs that can be activated from a custom light-up display base via a switch at the ship's rear. The model exhibits paint loss through use on set and time spent in storage. Dimensions: 30 cm x 64 cm x 46.25 cm (11.75" x 25.25" x 18.25")

Contains electronics; see electronics notice in the Buyer's Guide.

**Estimate: £8,000 - 16,000**



Engine LEDs can be activated via a switch at the ship's rear



Accessorized engine section features a Transformer's head

**326**  
 Production-made Starbug Model Miniature M  
**Red Dwarf (T.V. Series, 1988-2020)**

A production-made model-miniature Starbug from the BBC sci-fi comedy TV series Red Dwarf. The notoriously unreliable Starbug shuttles first appeared in Series III, and were the crew's primary mode of transportation to different planets, although they were often crashed by the crew.

This particular model was made for the Series VII episode "Tikka To Ride", specifically for the final scene after Lister (Craig Charles) loads up on thousands of vindaloos and poppadoms, and Rimmer (Chris Barrie) jettisons the cargo bay section of the ship, leaving Lister drifting in space with only his curries for company. Before the model was completed, the production decided that a CGI approach would be better, so it was never completed and given its distinctive space-worn paint effect.

The model is made from moulded plastic in two sections and accessorised using the 'kit-bashing' method, even featuring a Transformer's head on the engine section. It has original decals and a clear cockpit screen, and has since been fitted with replica fins and legs to make it look as originally intended. The model has some paint wear and the decals have been scratched.

Dimensions: 40 cm x 35 cm x 26 cm (15.75" x 14" x 10.25")

**Estimate: £5,000 - 10,000**



**327**  
 Angie Ashford's (Sophie Vasseur)  
 Screen-matched Light-up Lunchbox  
 with T-virus and Anti-virus Samples M  
**Resident Evil: Apocalypse (2004)**

Angie Ashford's (Sophie Vasseur) screen-matched light-up lunchbox from Alexander Witt's action-horror sequel Resident Evil: Apocalypse. Angie carried a "U-Formation Troopers"-themed lunchbox containing T-virus and anti-virus samples when she was found by Alice (Milla Jovovich). Distinctive markings on its interior and exterior surfaces match the lunchbox to the one seen on screen.

The lunchbox is made of tin and has an integral metal compartment tray that contains a foam insert holding a large metal-and-glass vial, four smaller metal-and-glass vials, and six metal vial lids. Inside each vial is a spiralling tube to contain the samples. A light underneath the insert illuminates when the relevant wires are connected to a 9V battery. The tray slides out from the side of the lunchbox when another set of wires are connected to three 1.5V AAA batteries and a stud at the box's rear end is pushed forward.

The production's property masters, Peter Clifford and Ron Dickie, designed and constructed the prop, while animatronic designer Walter Klassen fitted the lighting system. Klassen then sold the lot at an auction in the early 2000s. The spirals within the vials no longer have the appearance of containing vibrant green liquid, while the lunchbox exhibits some chips in its rim, and the end of the tray's outer layer is slightly loose. Dimensions: 22.5 cm x 20 cm x 10 cm (8.75" x 7.75" x 4")

Contains electronics; see electronics notice in the Buyer's Guide.

**Estimate: £10,000 - 20,000**





**328**  
 Captain Miller's (Tom Hanks)  
 Army Ranger Costume Ω  
**Saving Private Ryan (1998)**

Captain Miller's (Tom Hanks) Army Ranger costume from Steven Spielberg's Saving Private Ryan. Miller wore his standard-issue uniform and helmet throughout the film while his unit from the 2nd Rangers Battalion searched for Private Ryan (Matt Damon).

The film won five Academy Awards® out of 11 nominations and has been critically acclaimed as one of the greatest films ever made, with its iconic battle sequences cited as a major influence on subsequent war and action films.

This costume consists of a rehearsal helmet made from a standard helmet's inner particle board liner painted green to resemble a full helmet with green nylon and brown leather straps, "2" for the 2nd Rangers Battalion painted on the exterior, and "Miller" hand-marked on the interior; a matching jacket, button-up shirt, and undershirt; a tactical vest; a belt; two pairs of trousers with the army green one marked "Miller" on the tag; a pair of boot covers; and a pair of boots. Also included is one metal shovel and three canvas shovel covers.

The jacket also includes various built-in pockets with small amounts of sand in them, while the button-down shirt features a Rangers patch on the left sleeve and the vest features two pouches on a webbed belt stencilled with "U.S." This costume exhibits pulled threads on some seams, a buildup of grime in the pockets, and discolouration.

**Estimate: £15,000 - 30,000**



**329**  
 Captain Miller's Army Ranger Shirt ΩΔ  
**Saving Private Ryan (1998)**

Captain Miller's Army Ranger shirt from Paramount Pictures' Saving Private Ryan. School teacher and Army Captain Miller wore his Rangers shirt under his uniform throughout the mission he led to recover PFC James Francis Ryan.

This green cotton button-down shirt features brown wooden buttons, straps on either shoulder, and two small pinholes in the collar where a rank pin would be affixed. The shirt does not have shoulder patches, and exhibits stains on the collar and sleeves as well as small holes throughout the fabric from wear and age.

**Estimate: £4,000 - 8,000**



Captain John Miller's (Tom Hanks)  
 Colt M1911A1 Pistol



Sergeant Mike Horvath's (Tom Sizemore)  
 Colt M1911A1 Pistol

**330**  
 Captain Miller's (Tom Hanks) and  
 Mike Horvath's (Tom Sizemore) Colt M1911A1 Pistols μ  
**Saving Private Ryan (1998)**

Captain Miller's (Tom Hanks) and Mike Horvath's (Tom Sizemore) Colt M1911A1 pistols from Steven Spielberg's WWII drama Saving Private Ryan. Miller and Horvath carried their pistols throughout the film: Miller used his during his last stand in Ramelle and Horvath threatened Reiben (Ed Burns) with his as tempers flared after Wade (Giovanni Ribisi) died.

Both weapons are high quality replica pistols made of aluminium and tarnished to look well-used. They both feature a sliding bolt action and moveable triggers and hammers. Dimensions: (each) 21 cm x 13 cm x 3.5 cm (8.25" x 5" x 1.25")

Restricted ownership; see replica firearm notice in the Buyer's Guide.

**Estimate: £3,000 - 6,000**



**331**  
Jigsaw's Stunt Pig Mask  $\Omega$   
Saw Franchise (2004-Present)

Jigsaw's stunt pig mask from the Saw film franchise. Jigsaw (Tobin Bell), his apprentices, and other characters from the franchise wore pig masks as they carried out abductions and tests.

This rubber pig-faced mask is hand painted with dark grey and pink accents to give it a realistic appearance. It has production-applied blood to the eyes to give the impression it had been bleeding, and has hand-punched black synthetic hair as well. This mask features "Stunt" written on the interior in black ink and "Blair." This lot exhibits tangled and frayed fibres, pitting, and discolouration.

**Estimate: £5,000 - 10,000**



68.5 cm (27")

**332**  
Cast-Autographed One-Sheet Poster  $\Omega$   
Scream (1996)

A cast autographed one-sheet poster from Wes Craven's horror film Scream.

The poster has been signed by a number of top-billed cast members, including Neve Campbell (Sidney), Roger Jackson (Phone Voice), David Arquette (Deputy Dewey), Courtney Cox (Gale Weathers), Skeet Ulrich (Billy), Matthew Lillard (Stuart), Joseph Whipp (Sheriff Burke), Rose McGowan (Tatum), W. Earl Brown (Kenny), and Henry Winkler (Principle Arthur Himbry). Besides their autographs, the cast have written their characters names and lines from the film.

Dimensions: 101.5 cm x 68.5 cm (40" x 27")

The autographs in this lot have been professionally authenticated by expert Garry King; see notice in the Buyer's Guide.

**Estimate: £600 - 1,200**

**333**  
Henry Winkler-autographed  
Cut Ghostface Mask with  
Autographed Photograph  $\Omega$   
Scream (1996)

A cut Ghostface mask with a photograph from Wes Craven's Scream, both autographed by Henry Winkler. After he removed the masks from two students for playing a prank, Principal Himbry (Winkler) cut up one mask while he berated the students before he expelled them.

Scream won various awards, including three Saturn Awards in 1997, and has since been praised for its originality, meta commentary, humour, and ensemble cast, which were instrumental to the film's success.

Production used two types of masks during filming: commercial-made PVC masks from Fun World DIV, where they were used later in the film, and a limited run of masks designed by effects studio KNB EFX. Production intentionally cut up several masks for the scene with Himbry. This KNB EFX mask with a cut through the face originated from Winkler's personal collection.

Made of soft PVC painted white, it comes with black mesh inside the eyes, a blackened nose and mouth, and a black poly-blend fabric shroud. The forehead is signed by Winkler in black ink. Also included is a black-and-white still of Himbry with Sidney Prescott (Neve Campbell) signed and inscribed "I loved this" by Winkler in black ink. This lot exhibits discolouration on the interior of the mask, notable pen marks, and adhesive residue.

Dimensions: (photograph) 20.25 cm x 29.25 cm (8" x 11")

**Estimate: £30,000 - 60,000**



Autograph and inscription detail  
"Henry Winkler" "Himbry"





**334**  
Stab Preview Ghostface Robe m  
**Scream 2 (1997)**

A Stab preview Ghostface robe from Wes Craven's slasher sequel Scream 2. Some of the audience attending the preview screening of Stab, the film-within-a-film based on the Woodsboro massacre depicted in Scream, wore Ghostface robes. This hooded robe is made of black cotton Lurex. It features a Velcro attachment strip inside the top of the hood and gapping sleeves for a spooky effect.

**Estimate: £2,000 - 4,000**



**335**  
Ghostface Mask n  
**Scream 4 (2011)**

A Ghostface mask from Wes Craven's slasher sequel Scream 4. Killers wearing Ghostface masks tormented and murdered the residents of Woodsboro. The mask, originally based on Edvard Munch's The Scream, has become one of the most iconic villain disguises in film history.

Purchased by production for filming, this black-and-white rubber Fun World, Easter Unlimited, Inc. mask features an elongated screaming face, modified black mesh on the eyes, and a seam along the back. It comes with an attached black rayon hood and two front-side tassels. The lot originated with a crew member. It exhibits notable adhesive marks inside the mask and minor discoloration on the front.

**Estimate: £5,000 - 10,000**



**336**  
Ghostface Mask n  
**Scream (2022)**

A Ghostface mask from Matt Bettinelli-Olpin and Tyler Gillett's slasher sequel Scream. Killers wearing Ghostface masks tormented and murdered the residents of Woodsboro. The mask, originally based on Edvard Munch's The Scream, has become one of the most iconic villain disguises in film history.

The mask is made of rubber and has an attached black cotton hood. "MTV Edition #21" is handwritten in ink on the back of the chin. It comes with a letter of authenticity signed by R.J. Torbert, licencing director of Fun World, the company that originally developed the Ghostface mask for sale in novelty stores, and which licences the masks to the production. This states that the mask was used on the sets of both Scream (2022) and the Scream TV series.

**Estimate: £3,000 - 6,000**



39.5 cm (15.5")



Adjusted for readability

**337**  
Framed Detective Mills' (Brad Pitt)  
Printed Photograph n  
**SE7EN (1995)**

A framed Detective David Mills' (Brad Pitt) printed photograph from David Fincher's Se7en. Mills discovered a photo of himself inside the serial killer's home amongst other crime scene photos which revealed that the serial killer had been in close contact with Mills.

This lot consists of one framed printed photograph of Pitt as Mills as he told off a photographer from the crime scene. It exhibits some ink discoloration and water damage on the photograph itself. Dimensions: 39.5 cm x 31.75 cm x 2.5 cm (15.5" x 12.5" x 1")

**Estimate: £3,000 - 6,000**

**338**  
**Detective Mills' (Brad Pitt) Pinstripe Suit & SE7EN (1995)**

Detective David Mills' (Brad Pitt) pinstripe suit from David Fincher's *Se7en*. Mills wore his pinstripe suit while he investigated a string of grisly murders alongside retiring veteran officer William Somerset (Morgan Freeman), most notably as they investigated the murder revolving around gluttony.

With its bleak and grimy aesthetic, Fincher's *Se7en* is considered among the landmarks in the reinvention and invigoration of film noir in the late 20th century. As a result, its central detectives and their distinctive costumes have been seen in marketing material and critical discourse for decades since its theatrical release.

This costume consists of a black pinstripe wool Brooks Brothers jacket with matching trousers; a bass fish-patterned red silk Field & Stream necktie; a white cotton Studio Tokyo button-up shirt (size XL); and a pair of black cotton crew socks. This lot exhibits discolouration around the shirt collar and pilling on the wool suit.

**Estimate: £6,000 - 12,000**



Everett Collection Inc / Alamy Stock Photo



**339**  
**Mal's (Nathan Fillion) Screen-Matched Hero Liberty Hammer Pistol vs Firefly (T.V. Series, 2002 - 2003)/Serenity (2005)**

Mal's (Nathan Fillion) screen-matched Liberty Hammer pistol from Joss Whedon's *Serenity*. As Mal's favoured weapon, he carried and used his Liberty Hammer pistol throughout the film. Distinctive markings in the distressing of this pistol's metal exterior screen-match it to the scene in which Mal and his companions were pursued by Reavers after the heist.

*Firefly*, the television series, found success after its cancellation, with that unfortunately late success directly led to the franchise's continuation in the form of the theatrically-released feature film, *Serenity*. Despite lacklustre box office results, *Serenity* garnered positive approval from audiences and critics. It received several awards, including the Hugo Award for Best Dramatic Presentation, the Nebula Award for Best Script, and the Prometheus Special Award. It remains a culturally impactful film, with a collection of DVDs from the show and film, available on the International Space Station as entertainment for the crews.

This pistol was made for the television series, then modified for the film, differing slightly from its television appearance in that it features a removable magazine element that was added specifically for the film. This is one of only two live-fire versions of the pistol that were ever made. This pistol, built over a real Taurus Model 85 revolver with the serial number MC83218, features a production-made brass-colour metal housing that gives it the appearance of an otherworldly science-fiction weapon, a spring-loaded "slide" on the top of the gun which is movable by hand, a functional safety on the left side, a cover plate on the left side that was made removable to facilitate the loading and unloading of blank rounds, and brown wooden grips. One of the inner plates is marked "APPLIED FX" for the company that originally created the pistol for the *Firefly* series, before its reuse in the film. The pistol comes with a black nylon bag labelled "Serenity Nathan Fillion Taurus M. 85 SN: MC83218." In addition to production-made distressing and ageing to the metal, this pistol exhibits scuffing in the finish and small chips in the wooden grip. This pistol is being offered in deactivated state and will come with a U.K. certificate of deactivation. The pistol is currently undergoing deactivation and will ship to the winning bidder after the deactivation process is completed. Dimensions: 38 cm x 4.5 cm x 14 cm (15" x 1.75" x 5.5")

Firearm deactivated; see firearm deactivation notice in the Buyer's Guide.

Restricted ownership; see replica firearm notice in the Buyer's Guide.

**Estimate: £15,000 - 30,000**



Cinematic / Alamy Stock Photo



Serial number "MC83218" detail



**340**  
Shaun's (Simon Pegg)  
Screen-matched Bloodied Shirt and Tie m  
**Shaun Of The Dead (2004)**

Shaun's (Simon Pegg) screen-matched bloody shirt and tie from Edgar Wright's zombie comedy Shaun of the Dead. Shaun wore his shirt and tie throughout the zombie outbreak, which became bloodier and bloodier with each zombie he killed.

By the placement of the blood splatter, these items have been matched with the ones seen on-screen, specifically from the scene where Shaun and Ed (Nick Frost) kill the two zombies in their garden, to the moment Shaun runs into zombie Pete (Peter Serafinowicz) in their bathroom.

The white cotton shirt is labelled a size 16, buttons up at the front and features red paint splatters across the front, collar and sleeves. The accompanying tie has a diagonal stripe pattern in two tones of red and displays some white marks from production use.

**Estimate: £6,000 - 12,000**



**341**  
Ed's (Nick Frost) Bloodied "I Got Wood" T-Shirt m  
**Shaun Of The Dead (2004)**

Ed's (Nick Frost) "I Got Wood" T-shirt from Edgar Wright's zombie comedy Shaun of the Dead. Ed wore his T-shirt throughout the zombie apocalypse as it became increasingly bloodier.

This size "XXL" cotton T-shirt has been stained with stage blood and has a tear in the back intentionally caused by the production. "A1" is handwritten on the T-shirt's label in black ink.

**Estimate: £3,000 - 6,000**



**342**  
Shaun's (Simon Pegg)  
Stunt Cricket Bat and Storyboard Binder m  
**Shaun Of The Dead (2004)**

A stunt cricket bat and storyboard binder from Edgar Wright's comedy horror film Shaun of the Dead.

Shaun (Simon Pegg) used his cricket bat - which was his signature weapon throughout the film, and featured on promotional posters - to fight through the horde of zombies swarming his neighbourhood. The bat is made of foam, with a wooden dowel running through its centre, and has been painted to look wooden. The storyboard folder contains 190 pages of printed black and white storyboards, each annotated with the scene number and a brief description of the action occurring in each frame. The bat exhibits some paint damage and damage to the foam, and the handle has been taped around with duct tape. Dimensions (cricket bat): 83 cm x 29 cm x 10 cm (32.75" x 11.5" x 4")

**Estimate: £3,000 - 6,000**



STUDIOCANAL FILMS LTD / Alamy Stock Photo



Photo 12 / Alamy Stock Photo

**343**  
Barbara's (Penelope Wilton) Arm and Ed's (Nick Frost) Stunt Spade m  
**Shaun Of The Dead (2004)**

Barbara's (Penelope Wilton) arm and Ed's (Nick Frost) stunt spade from Edgar Wright's zombie comedy Shaun of the Dead. A zombie bit Barbara's forearm during the siege of the Winchester pub, and Ed fought off zombies with a spade during their first few encounters.

The arm is made of silicone with a large wound carved out of the underside of the forearm. A rubber tube runs through the top of the forearm, which would have been used to flush blood through to the wound, creating the illusion of profuse bleeding. A metal wedding ring is worn on one of the fingers. The spade comprises an armature covered in rubber painted to look like metal. The arm is missing sections of its fingers. Dimensions (spade): 100 cm x 19 cm x 11 cm (39.25" x 7.5" x 4.25")

**Estimate: £3,000 - 6,000**



# Sell Your Movie Memorabilia

Achieve world record prices for entertainment memorabilia



**Star Wars:  
Return of the Jedi (1983)**  
Imperial Scout Trooper  
"Biker Scout" Helmet

sold for \$315,000 (£252,000)\*

Reach out for a free appraisal and valuation with our specialists



Email: [consign@propstore.com](mailto:consign@propstore.com)  
UK Office: +44 (0) 1494 766485  
US Office: +1 818 727 7829

Scan QR code to visit [propstore.com/props](https://propstore.com/props)



**344**  
Ellis Boyd "Red" Redding's (Morgan Freeman)  
Prison Shirt Ω  
**The Shawshank Redemption (1994)**

Ellis Boyd "Red" Redding's (Morgan Freeman) prison shirt from Frank Darabont's *The Shawshank Redemption*. Red, the go-to man for contraband, wore his inmate shirt throughout the film as he befriended Andy Dufresne (Tim Robbins) where they created a grand prison library in memory of their friend, inmate Brooks Hatlen (James Whitmore) before they departed from Shawshank Prison to Zihuatanejo, Mexico.

The *Shawshank Redemption* earned seven Academy Award® nominations, including Best Picture, and was selected by the United States Library of Congress in 2015 to be preserved in the National Film Registry for being "culturally, historically, or aesthetically significant."

This lot consists of a blue and white striped long-sleeve, button-up cotton FiveBrother shirt (Size XL) marked "Western Costume Co. 16" with black buttons and a patch above the left breast pocket stenciled with the number "30265." This shirt exhibits fading colour to the inmate number.

**Estimate: £8,000 - 16,000**

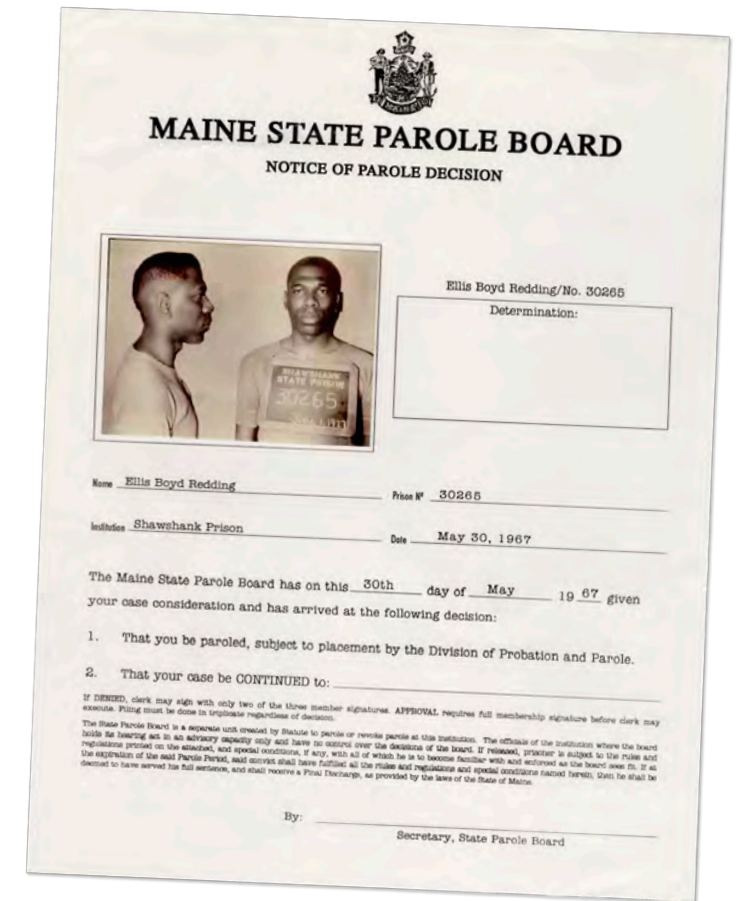

**345**  
Ellis Boyd "Red" Redding's (Morgan Freeman)  
Parole Decision Notice Ω  
**The Shawshank Redemption (1994)**

Ellis Boyd "Red" Redding's (Morgan Freeman) parole decision notice from Frank Darabont's *The Shawshank Redemption*. After serving over 40 years at Shawshank Prison, Red was granted parole after his honest statement of not knowing what it truly meant to be rehabilitated and admitting his regret for his actions.

This lot consists of an unstamped, black-and-white printed parole notice form dated May 30, 1967 featuring an adhered colour image of young Red with his inmate number. This lot exhibits minor discoloration around the edges. Dimensions: 21.75 cm x 28 cm (8.5" x 11")

**Estimate: £2,500 - 5,000**



**346**  
 Sherlock Holmes' (Robert Downey Jr)  
 Detective Costume M  
**Sherlock Holmes (2009)**

Sherlock Holmes' (Robert Downey Jr) detective costume from Guy Ritchie's action-adventure film Sherlock Holmes. Holmes wore his costume in several scenes, including the discovery of Reordan's (Oran Gurel) corpse in place of Lord Blackwood's (Mark Strong), and a battle against Blackwood's men.

The costume comprises a corduroy jacket, a white linen shirt and a pair of pinstripe cotton trousers. The jacket and trousers feature plastic buttons, and "8 R.D.J." is handwritten in black ink on a label inside the trousers. The costume also includes a floral patterned cotton waistcoat, a second pair of pinstripe cotton trousers, a striped neck scarf, and a brown leather belt with a metal buckle. "Robert Downey JR Sherlock Holmes" is handwritten on the waistcoat's costume label in black ink, while "MUDDY" is handwritten below this in pink ink, indicating that its intended use was for later in the fight sequence.

**Estimate: £8,000 - 16,000**



**347**  
 Troglorkhan Gorgonite Creature  
 Small Soldiers (1998)

A Troglorkhan creature from Joe Dante's action-comedy Small Soldiers.

This particular Gorgonite figure was used for early scenes of the film before he was destroyed by the Commando Elite and reconfigured as Freakenstein by fellow Gorgonites.

The blue resin figure features somewhat posable limbs, as well as numerous resin accessories, such as a club, dagger and shield. The model has some wear from production use, including paint wear, glue residue and a hole has been drilled through the chest.

The piece is standing on a custom display stand with the movie's logo which illuminates with the press of a button when powered.

Dimensions (display): 23 cm x 23 cm x 40 cm (9" x 9" x 15.75")

Contains electronics; see electronics notice in the Buyer's Guide.

**Estimate: £3,000 - 6,000**



**348**  
 Detective Rick Santoro's (Nicholas Cage)  
 Fight Night Costume  
**Snake Eyes (1998)**

Detective Rick Santoro's (Nicholas Cage) fight night costume from Brian De Palma's Snake Eyes. Santoro wore his costume during the events of fight night and in subsequent flashback scenes, until he switched to a more professional-looking brown suit with white shirt.

This lot consists of a multi-tone brown and orange polyester suit jacket lined in tangerine sateen; a yellow, orange, and brown cotton short sleeve button-up Hawaiian-themed floral shirt; and matching multi-tone brown polyester trousers. The interior of the jacket features a hand-marked "N.C." near the sleeve. This costume exhibits pulled and snagged threads.

**Estimate: £4,000 - 8,000**



**349**  
 Jack Traven's (Keanu Reeves) Costume M  
**Speed (1994)**

Jack Traven's (Keanu Reeves) costume from Jan de Bont's 1994 action film Speed. Jack wore his costume for most of the film as he tried to save the passengers of a bus rigged with a bomb. The costume consists of a jacket, shirt, T-shirt, pants and boots. The Quiksilver jacket (size "L") features a blue-and-brown plaid pattern and has two chest pockets; the Banana Republic shirt (size "M") is a blue cotton button-up; the T-shirt (size "L") is a white Calvin Klein; the AGOLDE jeans (size "31") are light brown; and the boots are brown leather Vasques.

The costume has some wear from production use and age. The jacket has faded over time, the shirt has some minor staining and several small holes on the front, the jeans have some brown staining around the shins, and the boots show wear to the heel and soles, with dried dirt on the soles.

**Estimate: £7,000 - 14,000**

**350**  
Green Goblin's (as played by Willem Dafoe)  
Hero Helmet with Bodysuit α  
**Spider-Man (2002)**

Green Goblin's (as played by Willem Dafoe) hero helmet with a bodysuit from Sam Raimi's Spider-Man. Deranged industrialist Norman Osborne wore his signature costume when his armoured alter-ego, Green Goblin, battled his arch nemesis, Spider-Man (as played by Tobey Maguire).

This lot consists of a hero fibreglass Green Goblin helmet with orange mesh-backed eyes hand-painted metallic green and hand-marked "No. 1" on the interior, as well as a matching green vinyl jumpsuit with fibreglass armour built onto the chest and arms and a John David Ridge costumier's tag on the interior labelled "Mr. Willem Dafoe" alongside illegible blue ink markings.

The exterior of the helmet has been touched-up with iridescent paint to create colour shifting under stage lighting, while the interior features wiring designed to illuminate lighting elements behind the eyes (though the current functionality of the wiring remains untested) as well as various fastening strips and metal fittings. While a cover plate at the rear underside of the helmet designed to mount into three posts on its top is missing, this example remains among the most complexly detailed and used Green Goblin helmets ever to come to market.

The bodysuit exhibits cracked vinyl and flaking paint from production wear and age, most visibly on the back of the neck; and the armour exhibits cracking throughout.

Contains electronics; see electronics notice in the Buyer's Guide.

**Estimate: £30,000 - 60,000**

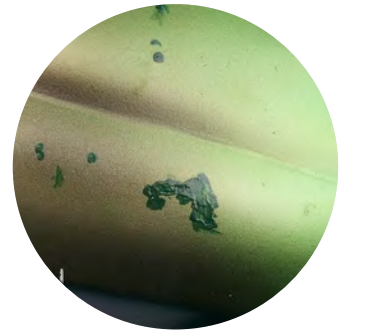



**350a**  
**Leonard Nimoy Collection: "Live Long and Prosper" Pendant**  
**Leonard Nimoy**

A "Live Long and Prosper" pendant modelled after the "Live Long and Prosper" hand gesture Leonard Nimoy famously made in his role as the Vulcan Spock. Leonard Nimoy starred as Spock in the original 1966 Star Trek series and continued to reprise throughout the franchise until 2013. For generations of fans, Nimoy's portrayal of Spock has inspired not only a love of science and exploration, but also a desire for peace and tolerance, celebrating the "Infinite Diversity in Infinite Combinations" that was the basis of Vulcan philosophy.

While a number of custom-designed pendants like this one were made, this particular pendant is one of only 10 that were flown into space on a Blue Origin flight in 2021. The other space-flown pendants are being awarded to select individuals who have either supported Leonard Nimoy's legacy or the spirit of the Live Long and Prosper symbol. So far, pendants have been awarded to Mayam Bialik, Billie Jean King, Neil DeGrasse Tyson, Levar Burton, and most recently, Whoopi Goldberg, who was awarded hers on November 1st 2024. This auction is the first time one of the pendants from the 2021 Blue Origin flight has ever been made available to the public.

This sterling silver pendant features a hand in the Vulcan gesture with "LLAP" engraved at the wrist. It comes on a metal silver-coloured chain with a lobster clasp and a black velvet bag with a gold-coloured top. This lot exhibits some minor build-up of grime in the fine crevices of the pendant. Dimensions: 5 cm x 5 cm x 0.75 cm (2" x 2" x 0.25")

Proceeds from this lot, curated by Julie Nimoy, daughter of Leonard Nimoy, and her husband David Knight, will go towards the creation of the Leonard Nimoy LLAP Memorial sculpture at the Museum of Science in Boston, and towards supporting COPD research being conducted by Dr. John Belperio and his team at UCLA Medical Center.

Additional Provenance: A Certificate of Flight from Blue Origin

**Estimate: £40,000 - 80,000**



**351**  
**Spock's (Leonard Nimoy) Screen-Matched Vulcan Kolinahr Tabard with Replica Robe**  
**Star Trek: The Motion Picture (1979)**

Spock's (Leonard Nimoy) screen-matched Vulcan Kolinahr tabard from Robert Wise's Star Trek: The Motion Picture with a replica robe. Spock wore his tabard at the beginning of the film as he took part in the Vulcan ritual of Kolinahr, in which all remaining emotions are purged. The tabard screen-matches through the intentional distress and markings all across the chest.

Spock is one of the most iconic characters in science-fiction, his emotional half-human side and his coldly logical half-Vulcan constantly at odds throughout the Star Trek films and TV shows. He was a valued advisor and confidant to James T. Kirk and he became one of the most important and respected people in the Federation.

The costume was designed by Robert Fletcher and constructed by Ted Shell Designs. The long tabard has been intentionally distressed all over to appear well-worn. It features a variety of geometric shapes on the front and back as decoration. There is a Western Costume Co. label in the neckline which has "Spock-Nimoy" handwritten in red ink. This label was added post-production for archival purposes. The costume is completed by a replica robe, modelled after the one worn by Spock with the tabard. The tabard underwent significant sympathetic restoration to recreate missing surface details. It exhibits some fraying around its edges and small holes from wear and age.

Additional Provenance: Letter of Authenticity from Ted Shell, who states that two such costumes were made and the other one was dismantled and used to make a costume for an extra in Star Trek V: The Final Frontier, making this costume unique.

**Estimate: £20,000 - 40,000**



**352**  
**Engineering Radiation Suit Costume**  
**Star Trek: The Motion Picture (1979)**

An Engineering radiation suit costume from Robert Wise's Star Trek: The Motion Picture. Starfleet engineers wore their orange and cream-colour radiation suits while aboard the Enterprise as they worked near the warp core.

This lot consists of an orange poly-blend fabric-covered black hard helmet lined with black cotton; one black foam collar; an orange poly-blend jumpsuit with a yellow rank armband, stirrups, and various resin components meant to simulate a technological interface on the jumpsuit; a pair of orange and cream-colour fleece-lined gloves marked "XL" on the interior from Grandoe; and orange boots with black rubber platform soles from Saba Oslo. The front of the jumpsuit displays a central mesh crest encircled by piping, a metal disc, two heavy-duty clips, and a "Strath" nametag. This lot exhibits discolouration, loose threads, cracking on the gloves, and chipped paint on the resin components.

**Estimate: £4,000 - 8,000**



Emotion chip detail



15.25 cm (6")

**353**  
**Lieutenant Commander Data's (Brent Spiner) Emotion Chip and Display Container**  
**Star Trek: Generations (1994)**

Lieutenant Commander Data's (Brent Spiner) emotion chip and display container from David Carson's Star Trek: Generations. After he committed the faux pas of pushing Doctor Crusher (Gates McFadden) into the water, Data decided to give his emotion chip another try to better understand the emotions of his fellow crewmates.

This lot consists of one resin "chip" inside of a clear acrylic display container with reflective chrome-colour banding on the cylinders. The chip is painted in a chrome-like gold-colour with copper-colour accents. This item has undergone sympathetic restoration to have the chip reassembled and suspended in the container. This lot exhibits adhesive residue, mild discolouration, chipped paint, and a missing chrome rim. Dimensions: 12.75 cm x 15.25 cm x 12.75 cm (5" x 6" x 5")

**Estimate: £6,000 - 12,000**



**354**  
 Doctor Tolian Soran's (Malcom McDowell) Phaser  $\Omega$   
**Star Trek: Generations (1994)**

Doctor Tolian Soran's (Malcom McDowell) phaser from David Carson's Star Trek: Generations. Soran used his phaser throughout the film, most notably as he kidnapped Geordi La Forge (LeVar Burton), and then later on Veridian III as he faced off against Captain Picard (Patrick Stewart) and Kirk (William Shatner).

This lot consists of one static solid phaser posed in its L-shaped firing position. Reminiscent of a scoped weapon, this predominantly resin phaser features metal accents, such as metal dials, scopes, and trigger guard plate. It's painted in black and grey with the metals featuring a chrome-like paint, as well as a copper-colour paint. This lot exhibits cracking inside the circular scopes, as well as indents in the grip and chipped paint. Dimensions: 12.75 cm x 18.75 cm x 14 cm (5" x 7.5" x 5.5")

**Estimate: £4,000 - 8,000**



Starfleet insignia on dark grey undershirt



**355**  
 Capt. James T. Kirk's Starfleet Uniform  $\Omega$   
**Star Trek Into Darkness (2013)**

James T. Kirk's Starfleet uniform from Paramount Pictures' sci-fi film Star Trek Into Darkness. Kirk, the captain of the Enterprise, wore his iconic yellow tunic throughout the film.

Star Trek Into Darkness was nominated for 41 awards within three years of its release, and won an IGN Award for Best Sci-Fi Movie. Additionally Benedict Cumberbatch won a Britannia Award for British Artist of the Year for his performance in the film.

The lot consists of a yellow Spandex-blend tunic with piping around the collar and a printed optical repeat Starfleet insignia pattern with a Michael Kaplan costumer's tag on the interior hand-marked "Kirk"; a dark grey cotton-blend undershirt with a Kaplan costumer's tag marked "DBL" with various other markings blacked out in ink; dark grey denim stretch trousers with ribbed fabric above the knees, built-in stirrups and a "36" printed tag on the interior; and suede leather boots with rubber soles marked "4" in silver-colour on the bottom. Also included are two production tags hand-marked for "Kirk" and the principal actor. This costume exhibits pulled threads and faded writing on the tags.

**Estimate: £6,000 - 12,000**



**356**  
 Klingon Guard Uniform with Disruptor  $\dagger$   
**Star Trek Into Darkness (2013)**

A Klingon guard costume with a disruptor from J.J. Abrams' sci-fi sequel Star Trek Into Darkness. Klingons wore their uniforms when they encountered the crew of the U.S.S. Enterprise in search of John Harrison (Benedict Cumberbatch) on the planet Kronos.

This costume consists of a breastplate; a pair of shoulder guards with an elastic harness; a scarf; a long-sleeved shirt (size XL); an undershirt (size XL); a pair of gloves; a pair of arm bracers; a codpiece; a pair of trousers (approximate waist size 28); a pair of thigh guards; a pair of knee pads; a helmet; a Klingon disruptor; and a pair of boots (US size 15).

The breastplate, shoulder guards, thigh guards, knee pads, arm bracers and codpiece are all made of foam rubber and mimic elephant hide. The scarf is made of a synthetic material and is lined with spandex. The long-sleeved shirt and undershirt are black spandex sports shirts. The gloves are made of black leather and suede.

The trousers are the same textured synthetic material as the sleeves and include black nylon suspenders. The helmet is made of dense urethane. The boots are made of black neoprene and rubber, and are distressed with dirt. The disruptor is painted in metallic shades of silver and is made of foam urethane.

The costume has been mounted on a custom-made display featuring the film's title. It features handwritten wardrobe labels, with many of the pieces marked with the actor's name. Also included are wardrobe tags with handwritten notes about the costumes. Dimensions (displayed): 15.75" x 25.25" x 80.25" (40 cm x 64 cm x 204 cm)

Special shipping required; see special shipping notice in the Buyer's Guide.

**Estimate: £5,000 - 10,000**



**357**  
 Capt. James T. Kirk's Light-up Transponder  $\Omega$   
**Star Trek Beyond (2016)**

Capt. James T. Kirk's light-up transponder from Justin Lin's Star Trek Beyond. After Jaylah's transponder was tossed away, Kirk activated his while on his bike and performed a daring jump to transport himself and Jaylah safely to the Franklin.

This lot consists of one light-up transponder made of resin with an orange light. It features a Starfleet delta with "CTGD-4469" painted on one side. It exhibits a scratch on one side, faded paint on the text, notable marks, and chipped paint. Dimensions: 11 cm x 7.75 cm x 4 cm (4.25" x 3" x 1.5")

Contains electronics; see electronics notice in the Buyer's Guide.

**Estimate: £3,000 - 6,000**

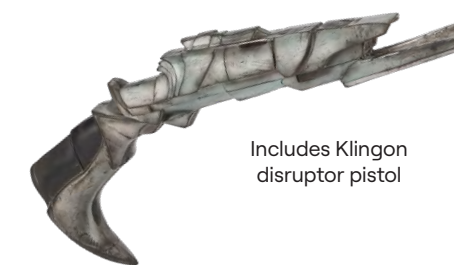

Includes Klingon disruptor pistol



Top red button switches on blinking red light



**No lot 358**

**359**  
 Patrick Stewart's Autographed  
 and Annotated Personal "In Theory"  
 Director's Script and Production Paperwork  $\Omega$   
**Star Trek: The Next Generation (T.V. Series, 1991)**

Patrick Stewart's personal autographed and annotated director's script and a set of paperwork from the production of the Season 4 episode "In Theory" of Star Trek: The Next Generation. The episode represented Stewart's directorial debut, and was later hand-picked by Stewart for inclusion in the DVD box set anthology Star Trek: Fan Collective - Captain's Log.

This lot originated from Stewart's personal collection. It consists of a final draft script for the episode with a yellow cover hand-marked "Patrick Stewart Director's Copy" and autographed by Stewart in black ink; various loose colour-coded revised final draft script pages, some with pencil markings; one shooting schedule; three call sheets; and two printed floor plans, including one for Data's (Brent Spiner) quarters. The script features handwritten annotations throughout. The pages exhibit some creasing and edge wear, including tearing. Dimensions: (largest) 23 cm x 28.75 cm x 1.5 cm (9" x 11.25" x 0.5")

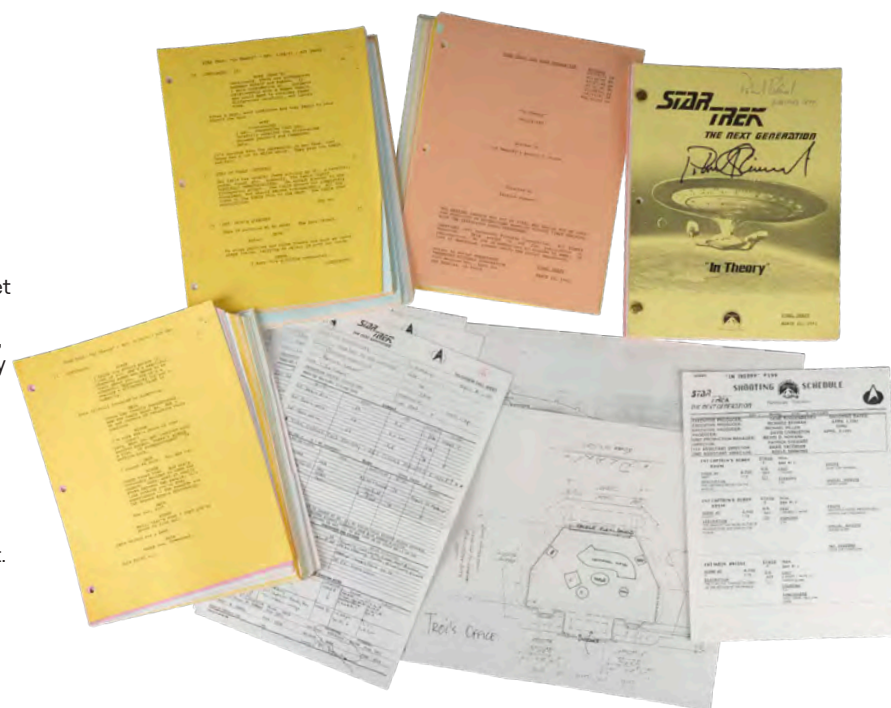

**Estimate: £3,000 - 6,000**



**360**  
 Romulan Tal Shiar Uniform +  
**Star Trek: Deep Space Nine (T.V. Series, 1993-1999)**

A Romulan Tal Shiar uniform from the sci-fi TV series Star Trek: Deep Space Nine. Elite Romulan intelligence agency operatives wore their uniforms in various episodes throughout the series.

This "Type C" uniform consists of a black ribbed jumpsuit with a zipped back and a metallic-grey quilted tunic. The tunic is decorated with a printed black-square pattern, and features a metallic-grey painted resin badge on the right cuff depicting a Romulan Bird-of-Prey. "Francis DellaVecchia" and "Mike McCaul" are handwritten in black ink on costume labels in both items. "George Callucci" is handwritten in black ink on a label inside the tunic, while "Dennis Madalone" is handwritten in black ink on a label inside the jumpsuit.

Also included is a harness-like studded belt predominantly made of rubber. This also features several Bird-of-Prey resin badges and fastens with hook closures.

**Estimate: £3,500 - 7,000**



Belt detail

**No lot 361**

**362**  
 Captain Kathryn Janeway's (Kate Mulgrew)  
 Starfleet Command Uniform  $\Omega$   
**Star Trek: Voyager (T.V. Series, 1995-2001)**

Captain Kathryn Janeway's (Kate Mulgrew) Starfleet command uniform from Star Trek: Voyager. As captain of the Intrepid-class Federation starship Voyager, Janeway wore her uniform throughout the series.

Star Trek: Voyager, which followed the crew of the titular vessel as they journeyed home from the Delta Quadrant, received 33 Emmy Award® nominations throughout its run and won seven, including multiple awards for visual effects. Mulgrew was also the first female lead to appear within the Star Trek franchise.

This costume originated from Christie's 40 Years of Star Trek: The Collection auction held in October 2006. It consists of a black wool-blend zip-front jumpsuit with maroon shoulders, a fastening strip on the left chest with a resin combadge marked "96" in ink, loops along the waist for hanging accessories; and a grey stretch zip-up long sleeve undershirt with turtleneck. Both items feature a sewn-in "VOYAGER" wardrobe label hand-marked "KATE MULGREW." The undershirt exhibits some discolouration, as does the trouser leg of the jumpsuit.

**Estimate: £10,000 - 20,000**



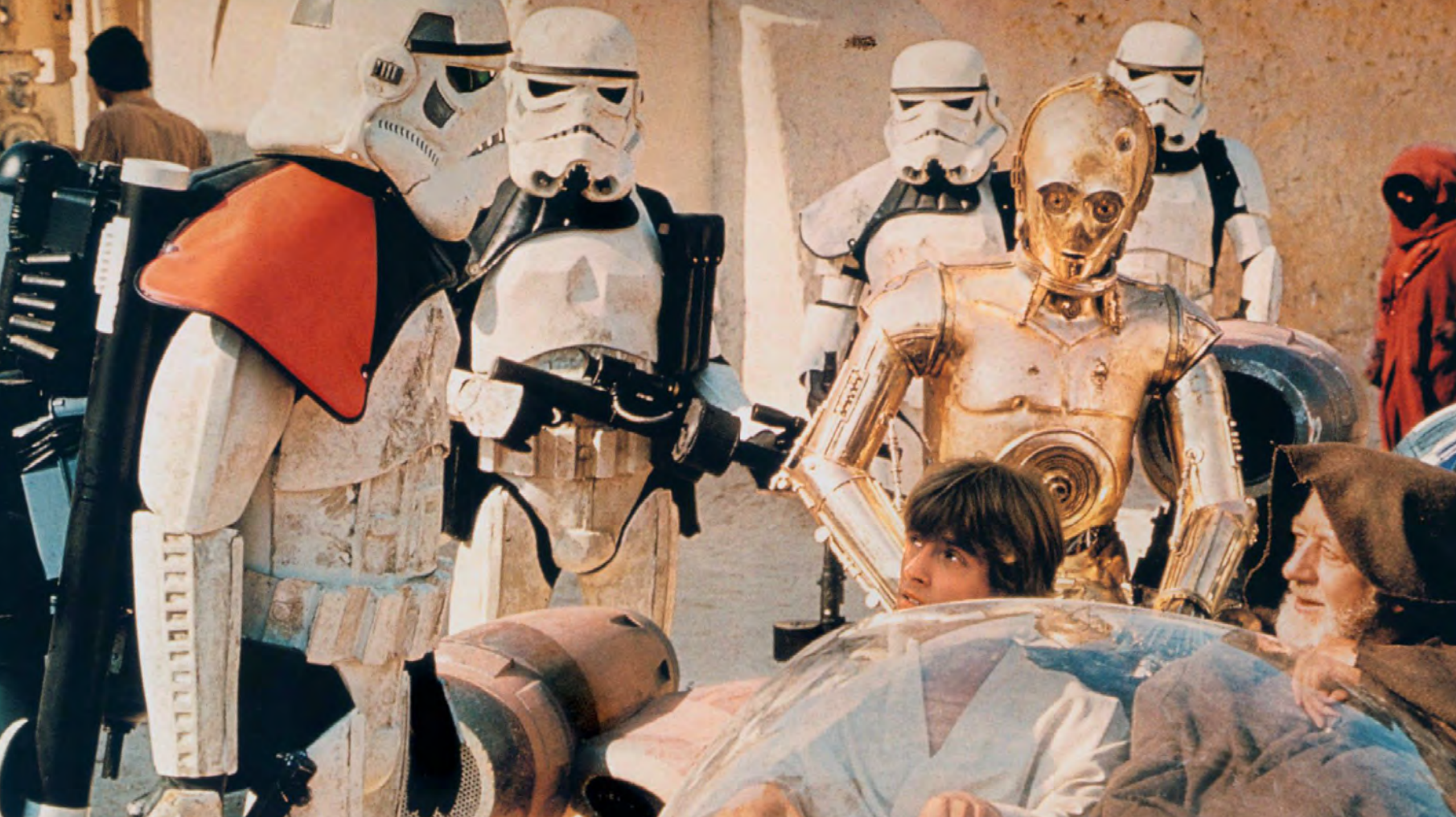

Allstar Picture Library Ltd / Alamy Stock Photo

THE FOLLOWING THREE LOTS COMPRISE A COMPLETE IMPERIAL STORMTROOPER (SANDTROOPER) COSTUME FROM STAR WARS: A NEW HOPE (1977)



**Lot 363**  
Screen-matched Stormtrooper (Sandtrooper) Helmet from Jedi Mind Trick Scene ("Move Along, Move Along") M

Estimate: £250,000 - 500,000



**Lot 364**  
Imperial Stormtrooper (Sandtrooper) Armour with Screen-matched Belt and Holster Rig M

Estimate: £250,000 - 500,000



**Lot 365**  
Imperial Stormtrooper E-11 Blaster Rifle M

Estimate: £60,000 - 120,000

**Let me see your identification.**  
*You don't need to see his identification.*  
**We don't need to see his identification.**  
*These aren't the droids you're looking for.*  
**These aren't the droids we're looking for.**  
*He can go about his business.*  
**You can go about your business.**  
*Move along.*  
**Move along... move along.**

*Star Wars: A New Hope*



The complete stormtrooper (sandtrooper) is offered across three lots to provide a better opportunity for those collectors specifically seeking a helmet, armour, blaster, or the complete costume.

(Lots 363, 364 and 365)



**363**  
 Screen-matched Stormtrooper (Sandtrooper) Helmet from Jedi Mind Trick Scene ("Move Along, Move Along") M  
**Star Wars: A New Hope (1977)**

The screen-matched "Jedi mind-trick" sandtrooper helmet from George Lucas' *Star Wars: A New Hope*. Sandtroopers, or desert stormtroopers, were stationed on Luke Skywalker's (Mark Hamill) home planet of Tatooine and could be regularly seen on patrol in the spaceport of Mos Eisley. Obi-Wan Kenobi (Alec Guinness) successfully used his Jedi mind-tricks to convince a platoon of sandtroopers that "these are not the droids you're looking for." This helmet screen-matches to the trooper that Obi-Wan performed the Jedi mind-trick on, who then told the group to "move along." The match is evidenced through unique paintwork on the teeth, paint runs on the side of the helmet, the organic forms of the hand-cut eye openings, and a distinct crack around the right side of the jaw.

Stormtroopers were part of George Lucas' earliest concepts for *Star Wars* and played prominently in each film of the original *Star Wars* trilogy. Lucas conveyed his ideas to seminal designer Ralph McQuarrie, who memorialised them in a series of concept sketches and production paintings. The costumes were realised for the film by the UK production crew, including costume designer John Mollo, sculptors Liz Moore and Brian Muir, and plastic-former Andrew Ainsworth. The exact count of stormtrooper helmets made for *A New Hope* is not known, but common consensus is less than 30, including only six sandtrooper helmets and body armours. Three sandtrooper helmets are known to survive: this example, one in George Lucas' archive, and another owned by a private collector.

This helmet has "Harding" scribed into the interior for stunt performer Reg Harding. It retains the original microphone tips at the front of the helmet, rubber trims at the brow and neck opening, and the interior foam padding. The original ears and green strip of acetate in the eyes were removed from the helmet during production, so these components have been replicated to complete the aesthetic. The replica ears were moulded directly from an original pair to ensure the highest degree of accuracy.

The helmet exhibits some wear from age and production use, most notably scuffs, scratches, paint wear and several small cracks.

The helmet is an exceptional example on account of the specific screen usage in one of *A New Hope's* most memorable scenes, the original unrestored paint finish, its overall condition and aesthetic, and its scarcity as a sandtrooper variant of the classic stormtrooper.

Dimensions: 30 cm x 31 cm x 30 cm (11.75" x 12.25" x 11.75")

**Estimate: £250,000 - 500,000**



Scan here to see a full rotation of this lot



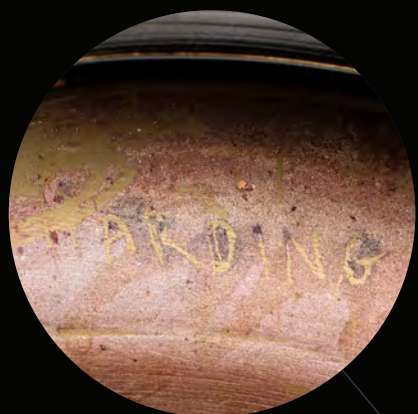

"Harding" is scratched into the helmet's interior for stunt performer Reg Harding, who played a stormtrooper amongst other roles in the film.



The helmet retains its original unrestored paint finish.

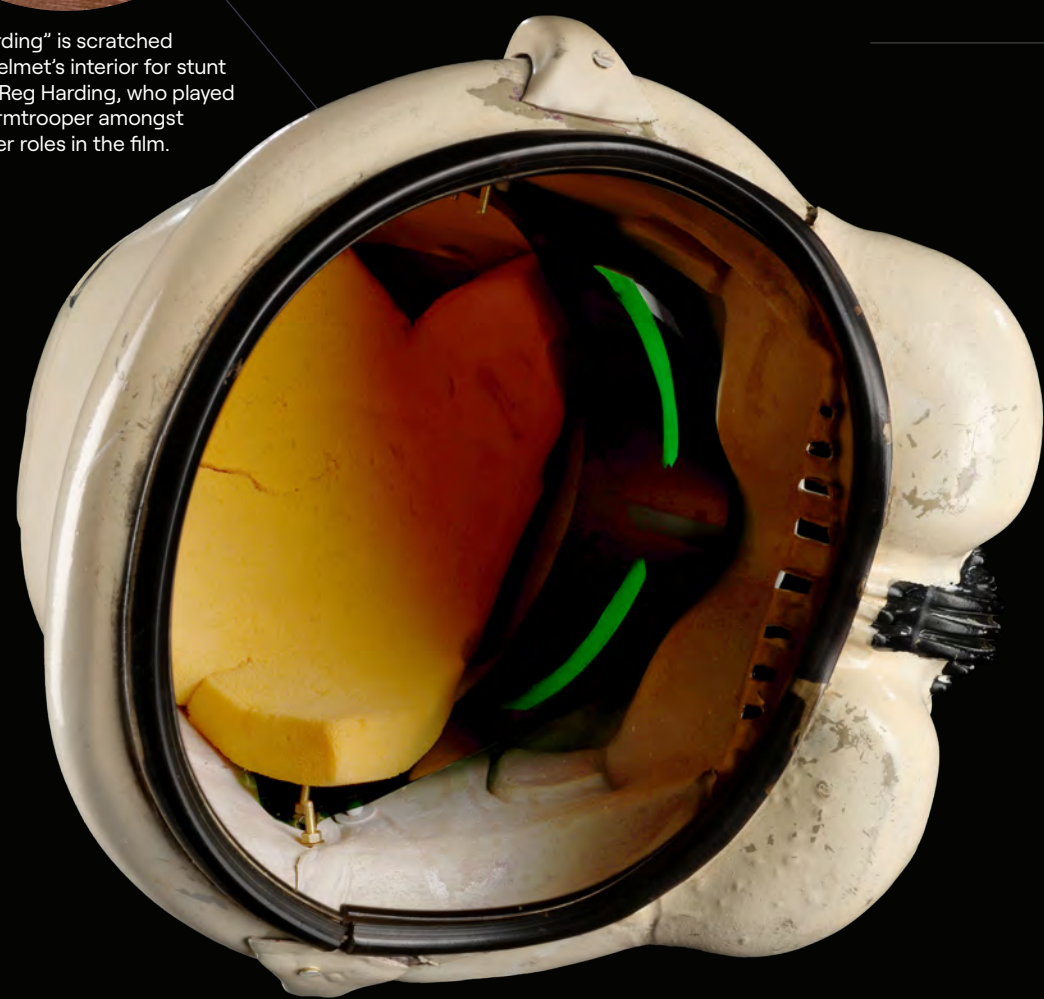

The helmet's mic tips, rubber trim pieces, and interior foam padding are original; the ears and green acetate eye lens are replicas.





A significant crack along the lower cheek tube on the stormtrooper (sandtrooper) helmet screen-matches to the Jedi Mind Trick "Move along... move along" scene.



This helmet was specifically worn by the stormtrooper (sandtrooper) from the memorable Jedi Mind Trick scene at Mos Eisley Spaceport.

Many unique characteristics match exactly to its appearance on screen 47 years ago.

The eye shapes on all helmets were hand-cut, and no two are identical. The grey "teeth" on the frown were also hand painted and unique to each helmet. These organic elements all line-up and match exactly to the helmet seen on screen, along with several chips and cracks.

**364**  
**Imperial Stormtrooper (Sandtrooper) Armour**  
 with Screen-matched Belt and Holster Rig  
**Star Wars: A New Hope (1977)**

A stormtrooper (sandtrooper) costume from George Lucas' Star Wars: A New Hope. Sandtroopers, or stormtroopers equipped for the desert, were stationed on Luke Skywalker's (Mark Hamill) home planet of Tatooine. Obi-Wan Kenobi (Alec Guinness) successfully used his Jedi mind tricks to convince a platoon of sandtroopers that "these are not the droids you're looking for."

Stormtroopers were part of George Lucas' earliest concepts for Star Wars and played prominently in each film of the original Star Wars trilogy. Lucas conveyed his concept to seminal designer Ralph McQuarrie, who memorialised them in a series of concept sketches and production paintings. The costumes were realised for the film by the UK production team, which included costume designer John Mollo, sculptors Liz Moore and Brian Muir, and plastic-former Andrew Ainsworth.

The first stormtrooper costumes assembled for the film were six sandtroopers that were sent for filming in Tunisia, where filming began. Production then made additional costumes that became known as standard Imperial stormtroopers. The initial six sandtroopers differed from the later-made stormtroopers in several ways: the torso armour had flat shoulder straps rather than ribbed; the belly plate was simpler, without a series of raised buttons; and the lower left leg featured a diamond-shaped knee plate.

This costume is comprised of fifteen original components: wrap-around torso armour, left and right arm assemblies consisting of shoulder, bicep, and forearm pieces, left and right leg assemblies consisting of upper and lower leg armours, a screen-matched belt and holster rig, a rear canister or "thermal detonator," a full-body under suit (with incorporated hole to facilitate the performer relieving themselves), and accompanying balaclava. Also included for display are replica components including boots, gloves with hand armour, a neck seal, a helmet (moulded from an original), and an orange sandtrooper shoulder pauldron.

The A New Hope torso components were assembled in a manner unique to this film—metal bars were mounted to the interior via small screws and elastic was attached to join the sections. At some point during production, likely for the rigours of promotion, the small screws along the bottom of the chest plate were replaced with larger screws and washers. The costume's right arm is marked "Right Arm" on the interior and the right thigh piece is labelled "Right."

The costume's leather gun holster screen-matches to the opening scenes when Darth Vader (David Prowse) and his stormtroopers boarded Princess Leia's (Carrie Fisher) ship Tantive IV. The two hanging belt boxes are wrapped with gaffer's tape; similar tape-wrapped boxes are seen in several screen stills and production photos.

This costume was used to promote the film upon its 1977 release in UK cinemas, after which it was retained by the performer. The left forearm and bicep plates were acquired at a later date and are from an original The Empire Strikes Back stormtrooper costume.

The costume exhibits light wear from production and age, and some paint loss, but remains in remarkable overall condition. A separation in the plastic of the codpiece has been sympathetically reinforced from the inside, and there is a small missing piece of plastic from the top of the left knee plate. This is the only sandtrooper costume known to still exist, making this a unique opportunity to own a significant part of Star Wars cinematic history.

**Estimate: £250,000 - 500,000**

**Stormtrooper (Sandtrooper) Armour original components**

- 1 - Wrap-around torso armour
- 2 - Shoulder right arm
- 3 - Bicep right arm
- 4 - Forearm right arm
- 5 - Shoulder left arm
- 6 - Bicep left arm
- 7 - Forearm left arm
- 8 - Upper right leg
- 9 - Lower right leg
- 10 - Upper left leg
- 11 - Lower left leg
- 12 - Screen-matched belt rig with affixed leather holster
- 13 - Thermal detonator
- 14 - Full body under-suit
- 15 - Balaclava

**Replica components** (illustrated grey in image at right)

- 1 - Sandtrooper helmet (cast from an original)
- 2 - Gloves
- 3 - Boots

Included with the original Stormtrooper (Sandtrooper) Armour is a replica helmet (shown here.) An original, film-used helmet is offered separately in lot 363.

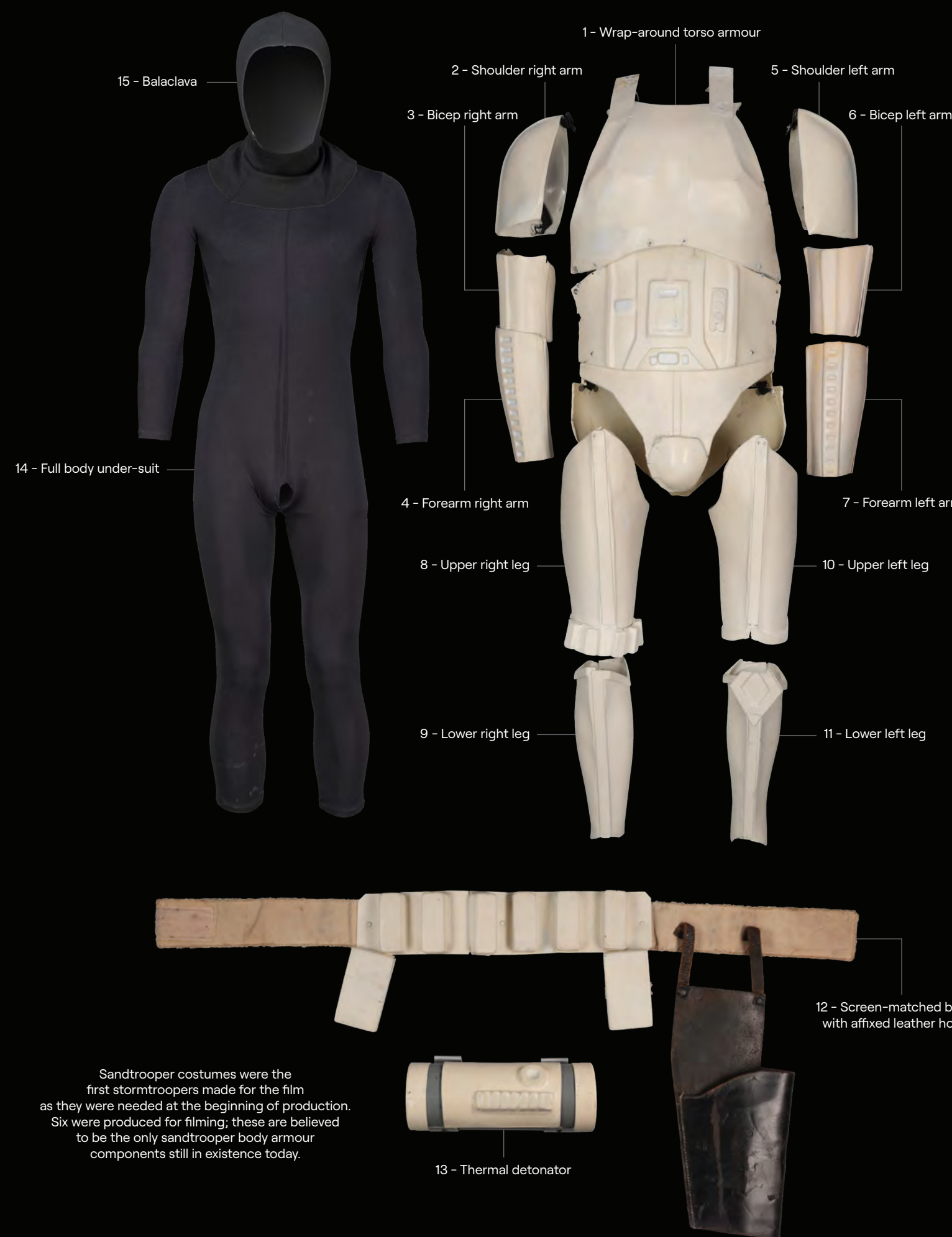

Sandtrooper costumes were the first stormtroopers made for the film as they were needed at the beginning of production. Six were produced for filming; these are believed to be the only sandtrooper body armour components still in existence today.



The Stormtrooper costumes for Star Wars: A New Hope were made from vacuum-formed plastic; the various components were assembled with hardware, fasteners and elastic unique to the first movie.



Wrap-around torso armour (interior view)



Smooth shoulder straps detail

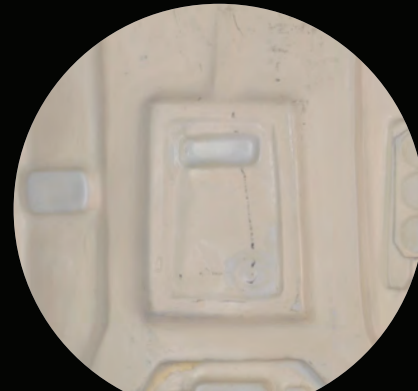

Front abdomen "belly" plate

Sandtrooper costumes had unique elements compared to standard stormtrooper costumes including the front abdomen "belly" plate without raised buttons, the diamond-shaped plate on the left knee as opposed to the traditional stormtrooper knee, and the smooth shoulder straps connecting the chest and upper back plates as opposed to ribbed straps.



Interior torso fastener details



Diamond-shaped knee plate

The belt boxes are held together with white gaffer's tape, an element seen on stormtroopers in the film and in production photos.



An identifiable vertical scratch mark and two surface indentations screen-match the holster (permanently affixed to the belt) to a stormtrooper visible during the opening sequence on the Tantive IV. The holster is also riveted to the exterior of the belt rather than the interior of the belt, as most stormtroopers were.



**365**  
**Imperial Stormtrooper E-11 Blaster Rifle m**  
**Star Wars: A New Hope (1977)**

A model E-11 Imperial Stormtrooper blaster from George Lucas' Star Wars: A New Hope. The BlasTech E-11 blaster rifle was the standard-issue rifle for Imperial stormtroopers, who used them while hunting for the Death Star plans, and in their battles with the heroes on board the Death Star. They were also used in the Mos Eisley scenes, the desert sequences filmed in Tunisia, and the trash compactor scene.

This weapon, based on an L2A2 Sterling submachine gun, was fabricated especially for Star Wars by theatrical armourers Bapty & Co. and was returned to the company after the completion of filming. It was designed in such a way that armourers would not be required on set.

The weapon is made from a Sterling body tube with a wooden-dowel barrel and custom-made aluminium components for the receiver, magazine well, stock, pistol grip and trigger guard, all of which are finished in black paint. Years after

production, the piece was rediscovered in the Bapty armoury, stripped of its various dress-up components, and restored by Propstore.

The replacement M38 scope is a functional Azimuth tank scope obtained from Bapty armourer Karl Schmidt (creator of the original prop weapons), and may be one of the originals used in Star Wars. A steel scope rail made to the original specifications has also been fitted, along with plastic barrel ribs, magazine cylinders and a contemporary Hengstler counter. Well-used during filming, this blaster displays some paint wear and scuffing.

Dimensions: 49 cm x 21 cm x 13 cm (19.25" x 8.25" x 5.25" )

**Estimate: £60,000 - 120,000**



49 cm (19.25")



Sight power unit displays "1138" as an homage to George Lucas' first feature length film, "THX 1138"



44.5 cm (17.5")

**366**  
R3-series Astromech Droid Dome  $\Omega$   
**Star Wars: A New Hope (1977)**

An R3-series astromech droid dome from George Lucas' *Star Wars: A New Hope*. Though very similar in appearance to R2-series droids, most R3-series were distinguished by their unique transparent domes, through which their internal mechanisms were visible. One such droid was passed by Obi-Wan Kenobi (Alec Guinness) in the corridor aboard the Death Star when Kenobi was on his way to the tractor beam controls.

Originally titled simply *Star Wars* and later given the subtitle *A New Hope*, the original 1977 film was a pop culture phenomenon and is widely considered one of the most influential films ever made. The film launched the massive *Star Wars* franchise, which is still going strong nearly 50 years later.

This dome is made of clear acrylic and features black, white, and gold-colour line work in the form of decals applied throughout. It exhibits scratching and scuffing throughout the acrylic, as well as tears and lifting in the decals. Dimensions: 44.5 cm x 44.5 cm x 21.75 cm (17.5" x 17.5" x 8.5")

**Estimate: £25,000 - 50,000**



R3-series rolling past Stormtroopers through the Death Star corridor in *A New Hope*

**367**  
Rebel Fleet Trooper Vest m  
**Star Wars: A New Hope (1977)**

A Rebel fleet trooper vest from George Lucas' *Star Wars: A New Hope*. The Rebel Alliance wore vests throughout the film, including scenes aboard the *Tantive IV* corvette while protecting Princess Leia (Carrie Fisher), and on Yavin IV, both before the assault on the Death Star and during the medal ceremony.

Designed by Oscar-winning costume designer John Mollo and manufactured by A.E. Bickel and Co. for Bermans & Nathans, who provided costumes and accessories for the production, this pocketed and pouched black vest is made of a Teredo poly-cotton blend. In line with Lucas' vision for the *Star Wars* universe, this vest has no fastenings along the front, and some pockets have tab closures, while others have Velcro closures. The vest exhibits fraying along the seams and fading to the internal label.

**Estimate: £5,000 - 10,000**

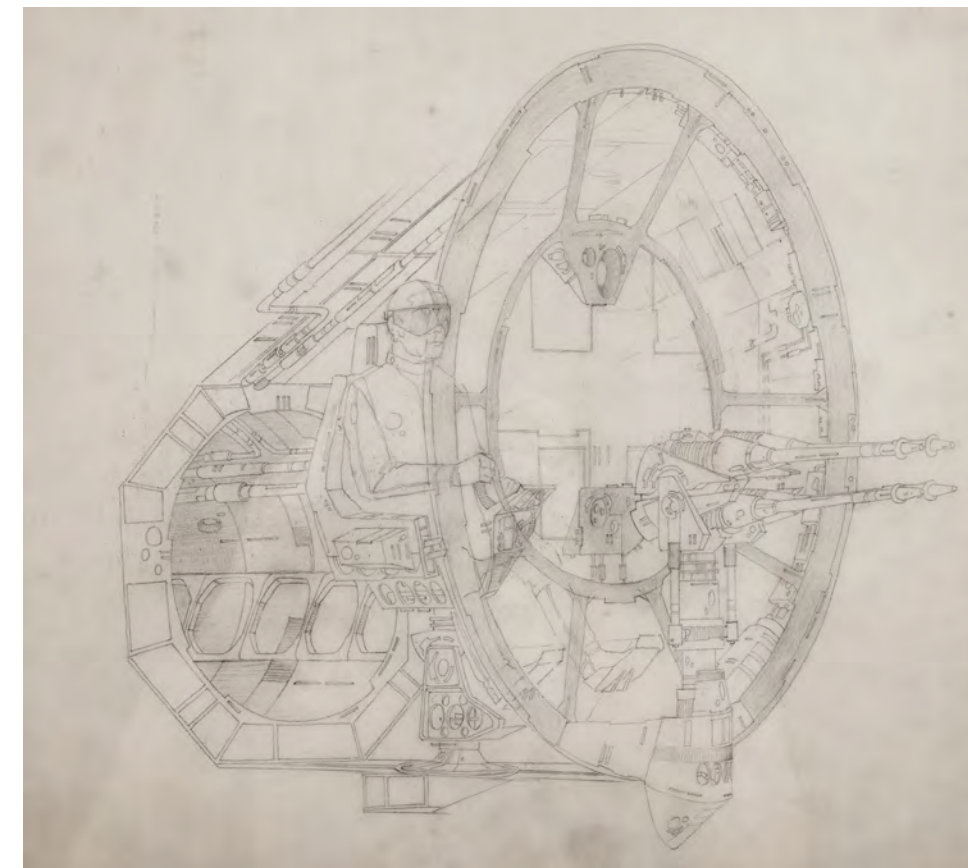

60 cm (23.5")  
Adjusted for readability

**368**  
Hand-drawn Harry Lange  
Millennium Falcon Laser Cannon  
Concept Illustration m  
**Star Wars: A New Hope (1977)**

A concept illustration of the Millennium Falcon's laser cannon hand-drawn by Harry Lange for the production of George Lucas' *Star Wars: A New Hope*. Luke Skywalker (Mark Hamill) and Han Solo (Harrison Ford) used the Falcon's laser cannons to battle Imperial fighters.

Production designer and art director Harry Lange was a pioneer in his field. His designs helped shape the modern sci-fi landscape through movies such as *2001: A Space Odyssey*, *Star Wars*, and *The Dark Crystal*.

The artwork is rendered in pencil on tracing paper and has been displayed in a custom-made frame. It has minor wear to the edges, discolouration and smudge marks. Dimensions (display): 60 cm x 60 cm x 5 cm (23.5" x 23.5" x 2")

Sold without copyright; see copyright notice in the Buyer's Guide.

**Estimate: £5,000 - 10,000**

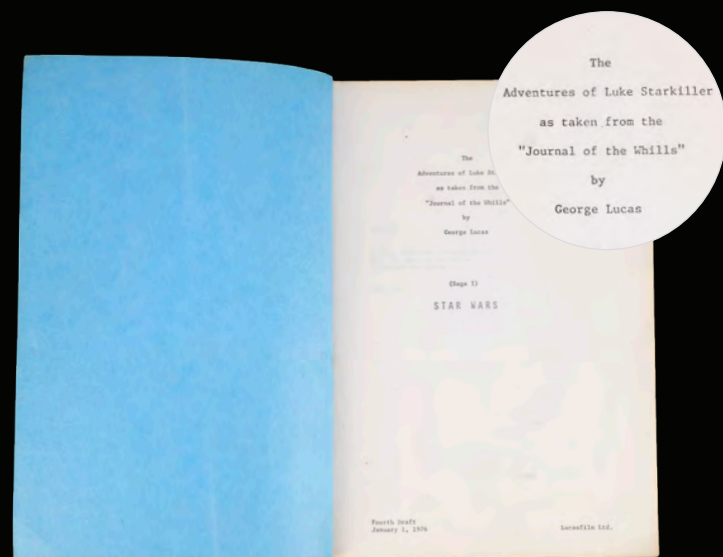

The Adventures of Luke Starkiller as taken from the "Journal of the Whills" by George Lucas



FIRST DRAFT JULY 1974

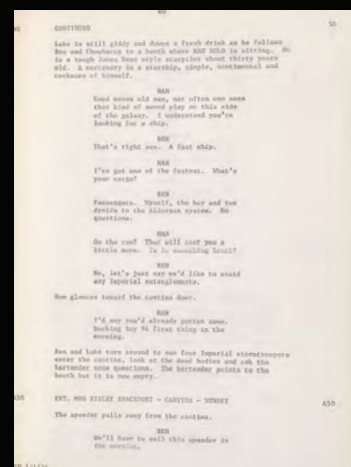

and downs a fresh... Dean style starpilot about... in a starship, simple, sent... himself.  
HAN  
Good moves old man, not often one sees that kind of sword play on this side of the galaxy. I understand you're looking for a ship.  
BEN  
That's right son. A fast ship.  
HAN  
I've got one of the fastest. What's her cargo?  
BEN  
Wheelf, the...

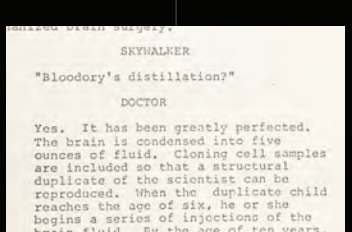
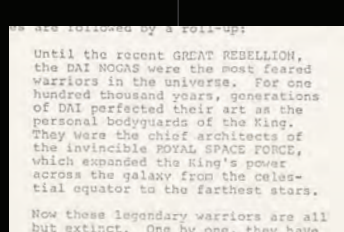
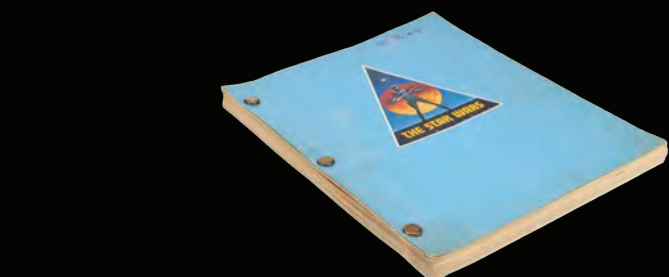
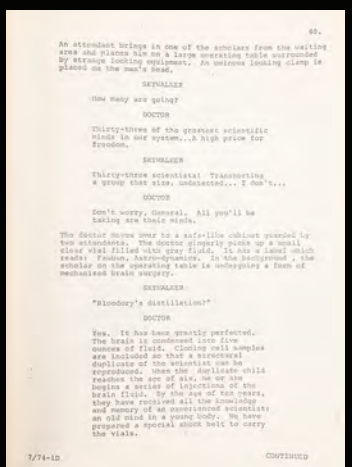
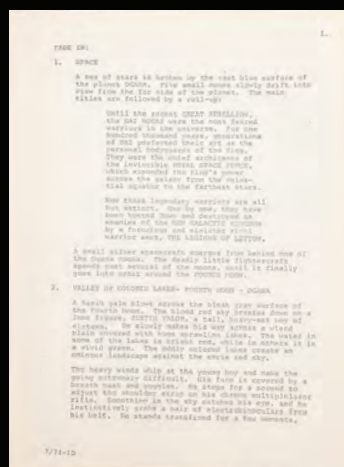

**369**  
Fourth Draft Script of  
**Star Wars: A New Hope (1977)**

A fourth draft script from George Lucas' Star Wars: A New Hope. The script features a header on page 1 for "The Adventures of Luke Starkiller as taken from the 'Journal of the Whills' by George Lucas."

Lucas was nominated for an Academy Award® for Best Writing Screenplay Written Directly for the Screen and won a Saturn Award for Best Writing. Lucas was also nominated for a Writers Guild of America Award for Best Comedy Written Directly for the Screen.

This 145-page script, fourth draft dated "January 1, 1976," is marked "R Bird." It is secured with metal binder clips and stickered on the front with an early Ralph McQuarrie production logo for "The Star Wars." This script exhibits various signs of wear and handling throughout, including discolouration. Dimensions: 28 cm x 23 cm x 2.5 cm (11" x 9" x 1")

**Estimate: £4,000 - 8,000**

**370**  
"The Star Wars" First Draft Studio Copy Script of  
**Star Wars: A New Hope (1977)**

A first draft script copy for George Lucas' Star Wars: A New Hope. Dated "July 1974", this 146-page screenplay bears the original title "The Star Wars", and is the first revision to the rough draft completed only months earlier.

Bound with a red plastic front and back cover, this studio copy offers remarkable insight into the creation of the beloved first film in this hugely successful saga. It includes many character names and locations, which were omitted in the second draft, titled "Adventures of the Starkiller, Episode I: The Star Wars". Dimensions: 22 cm x 28 cm x 2 cm (8.5" x 11" x 0.75")

**Estimate: £5,000 - 10,000**

**371**  
Harrison Ford's  
Personal Hand-annotated  
Shooting Schedule and Paperwork from  
**Star Wars: A New Hope (1977)**

Harrison Ford's personal hand-annotated shooting schedule and other pieces of his paperwork from the production of George Lucas' Star Wars: A New Hope.

Ford's performance as Han Solo in Star Wars and its sequels made him one of Hollywood's biggest actors, leading to such cinematic triumphs as the Indiana Jones series, Blade Runner and the Jack Ryan thrillers. Ford was recently presented with an honorary Palme d'Or, when Indiana Jones and the Dial of Destiny premiered at the Cannes Film Festival.

This shooting schedule includes the times and dates for all of Ford's scenes as Han Solo, from late April to mid-June 1976. The schedule is hand-annotated on the back of the last page.

Also included in the lot is a second, partial shooting schedule, and handwritten notes, reminders and calculations, which appear to relate to Ford's professional and personal life. Dimensions (shooting schedule): 30 cm x 22 cm (11.75" x 8.75")

**Estimate: £3,000 - 6,000**

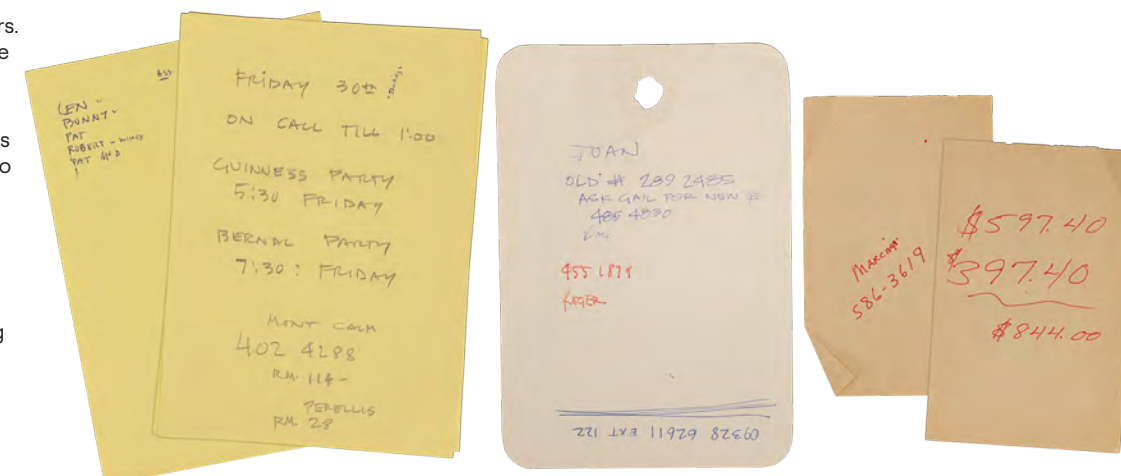
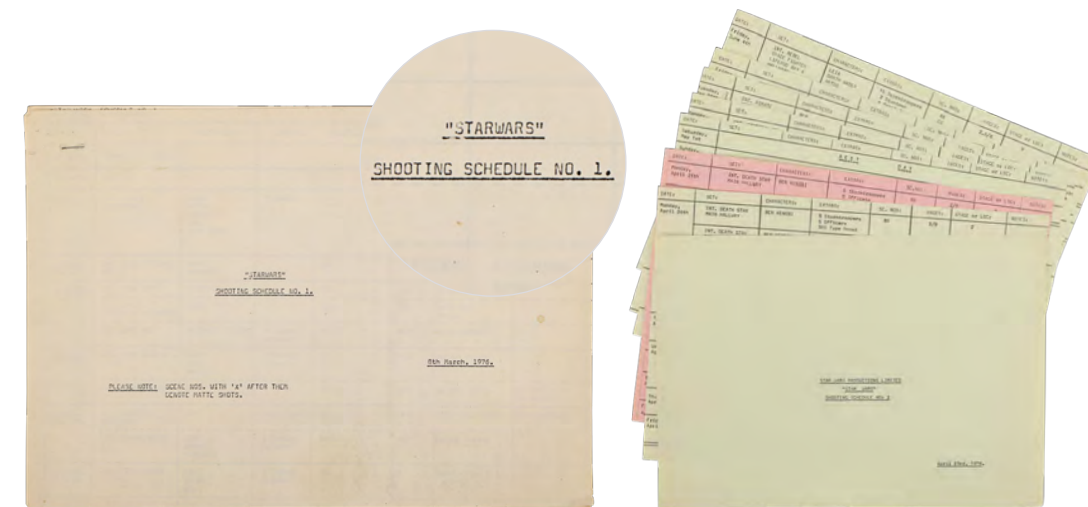

Handwritten notes by Harrison Ford

**372**  
Hildebrandt UK Quad of  
**Star Wars: A New Hope (1977)**

A poster designed by the Brothers Hildebrandt for George Lucas' Star Wars: A New Hope. After a very limited release, this poster was withdrawn and replaced by the more commercial "Style C" poster featuring Tom Chantrell's artwork. It is rated 5.0/6.0 by starwarsmovieposter.com for rarity, and has a 10/10 rarity rating in Stephen Sansweet's Star Wars Poster Book, the industry bible for Star Wars posters. It has been conservation linen-backed. Dimensions: 78.75 cm x 104.25 cm (31" x 41")

**Estimate: £4,000 - 8,000**



104.25 cm (41")



50.5 cm (20")

**373**  
Howard Chaykin Poster M  
**Star Wars: A New Hope (1977)**

A Howard Chaykin "Poster #1" from the promotion of George Lucas' Star Wars: A New Hope. Chaykin's poster debuted at the 1976 Comic-Con and was the first introduction to the Star Wars saga for unsuspecting attendees, along with a Marvel comic-book series which was drafted by the artist to help generate interest for the film's release the following year.

Composed in Chaykin's original high-detail comic-book style, this poster features a collage of key aspects of the film. Luke Skywalker stands at the front, backed by a blaster-wielding Han Solo, Princess Leia and Obi-Wan Kenobi. Behind them looms Darth Vader, against the Death Star, and X-Wings, Y-Wings, and T.I.E. Fighters are depicted on the poster's lower half. "Star Wars" is written in red in the bottom right corner.

The text in the bottom margin reads "Poster 1, 1st edition artist: Howard Chaykin, Luke Skywalker". A copyright symbol prefaces the final text, "The Star Wars Corporation 1976", a detail only present on original posters, distinguishing the piece from reprints that surfaced years later. This poster shows some edge wear, most notably on the top right corner, and has been conservation linen backed. Dimensions: 73.5 cm x 50.5 (29" x 20")

**Estimate: £5,000 - 10,000**



**374**  
Complete Marler Haley Set - UK Quad  
with Four Double Crowns, 1977 M  
**Star Wars: A New Hope (1977)**

A complete set of Marler Haley posters from the promotion of George Lucas' Star Wars: A New Hope. Printing company Marler Haley produced a limited quantity of posters exclusively for the Odeon cinema chain as a special promotion for the film. The line comprised a UK Quad and four British Double-Crowns, all of which featured different designs to the main advertising campaign.

Offered in this lot is a complete set comprising the four double crowns - "Adventure", "Excitement", "Heroes", "Villains" - and the starburst Princess Leia-centred British quad. These are some of the rarest and most sought-after of Star Wars collectables.

All the posters are conservation linen-backed with minimal restoration done to a high standard. They remain in excellent condition. Dimensions (UK Quad): 76 cm x 102 cm (30" x 40")

**Estimate: £4,000 - 8,000**



Pictorial Press Ltd / Alamy Stock Photo

**375**  
Yoda's (Frank Oz) Gimer Stick α  
**Star Wars: The Empire Strikes Back (1980)/  
Star Wars: Return Of The Jedi (1983)**

Yoda's (Frank Oz) gimer stick from Irvin Kershner's Star Wars: The Empire Strikes Back and Richard Marquand's Star Wars: Return of the Jedi. The legendary Jedi Master famously carried a walking stick throughout the Star Wars films, including his years in exile and training Luke Skywalker (Mark Hamill) on Dagobah.

Yoda was brought to life in the original films using a highly detailed puppet sculpted by artist Stuart Freeborn and performed (both in puppeteering and in voice) by celebrated Muppet performer and filmmaker Frank Oz. Yoda quickly became one of the most popular and iconic characters in the Star Wars franchise, later appearing in both the prequel and sequel trilogies.

This cane originated from Bonhams' 2005 Rock & Film Memorabilia auction. It is made of cast resin with sculpted details and brown paint to resemble a twisted length of aged wood with a knot at the handle for Yoda to hold onto. It exhibits some scuffs in the painted finish.

Dimensions: 51 cm x 10.25 cm x 6.5 cm (20" x 4" x 2.5")

**Estimate: £20,000 - 40,000**



51 cm (20")



A tapped hole at the bottom was used for the puppeteering rod



**376**  
 Hoth Rebel Trooper  
 A295 Blaster Rifle m  
**Star Wars:**  
**The Empire Strikes Back (1980)**

A Hoth Rebel trooper A295 blaster rifle from Irvin Kershner's *Star Wars: The Empire Strikes Back*. Rebel troopers wielded A295 blaster rifles during the Battle of Hoth, as they defended Echo Base against Imperial AT-AT walkers and ground troops.

The Battle of Hoth was created using a combination of model-miniature work filmed at Elstree Studios in England and location shooting in Finse, Norway. Many locals, including mountain-rescue skiers, were hired to portray the Rebel troops, and a donation was made to the Norwegian Red Cross by Lucasfilm in return for their participation. The consignor visited the film set as a child and was gifted this weapon by a member of the crew.

This standard-issue rifle comprises a cast resin World War II German Sturmgewehr 44 body, with components added to produce a unique aesthetic for the production. These additional features are finished in black paint, and include a wooden "T"-shaped stock, a ribbed-grip pump, and a modified barrel. A non-functioning scope adorns the top of the body and the weapon features a static trigger.

An adjustable leather carrying strap is secured to the weapon via two metal D-rings. The rifle displays signs of production use, most notably the removal of the end of the barrel. There is also paint wear, scuff marks and cracks and chips to the resin along the body. The leather strap exhibits cracking and there is minor corrosion present on the D-rings. This lot is accompanied by a printed still. Dimensions: 71 cm x 26 cm x 6 cm (28" x 10.25" x 2.25")

**Estimate: £20,000 - 40,000**



71 cm (28")





"Lucasfilm Ltd" logo on first page

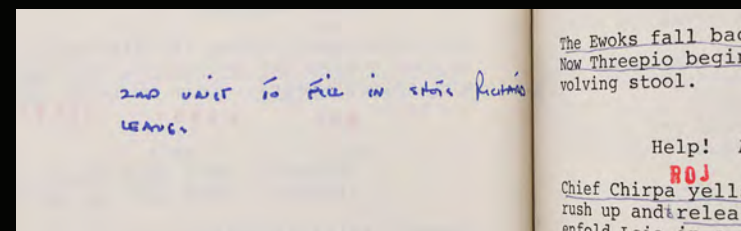
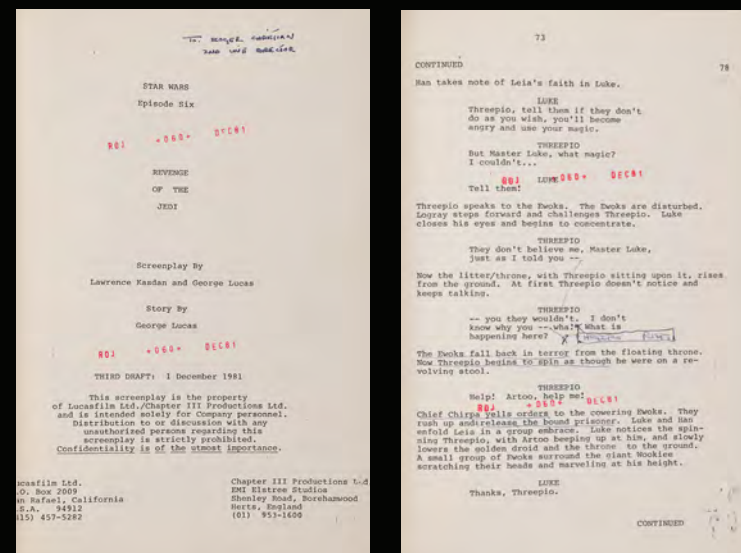

**377**  
**Roger Christian's Personal Hand-annotated Script m**  
**Star Wars: Return Of The Jedi (1983)**

Roger Christian's personal hand-annotated script from the production of Richard Marquand's Star Wars: Return of the Jedi. This script was issued to Christian, who served as second unit director during production, and it was used while shooting the Ewok Village scenes. Christian had previously won the Academy Award for Best Art Direction and Set Decoration for his work as a set decorator on Star Wars: A New Hope. Full scripts from the production are a rarity. Bound in a green leather springback binder, the script displays an embossed Lucasfilm logo on its card cover page. The title page bears the original working title "Revenge of the Jedi", and features "To Roger Christian, 2nd Unit Director" handwritten in blue ink.

Dated 1 December 1981, the 107-page script is printed single-sided on white US Letter paper, with inserted yellow revision pages. Each page displays two red security stamps, each reading "ROJ +060+ DEC81". Handwritten annotations appear throughout, relating to the second unit camera team. Dimensions: 32 cm x 24.25 cm x 4 cm (12.5" x 9.5" x 1.5")

**Estimate: £6,000 - 12,000**

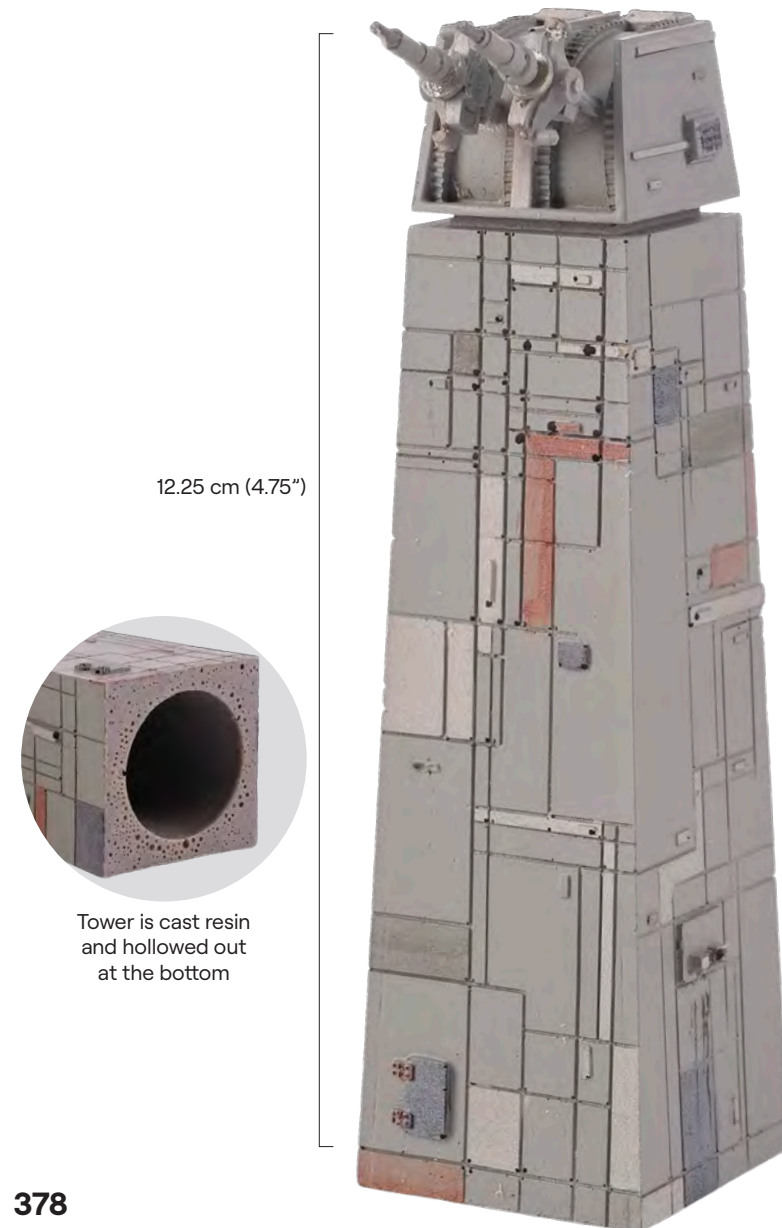

12.25 cm (4.75")

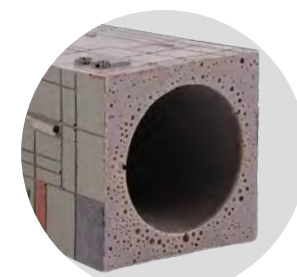

Tower is cast resin and hollowed out at the bottom

**378**  
**Screen-Matched Death Star**  
**Turbolaser Tower Model Miniature α**  
**Star Wars: Return Of The Jedi (1983)**

A screen-matched Death Star turbolaser tower model miniature from Richard Marquand's Star Wars: Return of the Jedi. Much like its predecessor, the Death Star II's surface was lined with powerful gun turbolaser turrets, with this particular turret located near the Emperor's (Ian McDiarmid) Tower. The hand-painted brown details in the tower's darker panels, such as the vertical detail that forms the "J"-like shape, screen-match to the wide establishing shot of the towers lining the Death Star's surface before the scene where the Emperor gave the order to send the fleet to the far side of Endor.

The Rebel fleet's assault on both Death Stars in the Battles of Yavin and Endor in A New Hope and Return of the Jedi, respectively, are considered two of the most visually-stunning sequences in the Star Wars franchise. The elaborate space battles were brought to life by Industrial Light & Magic (ILM) through the use of expansive model miniatures representing the heavily armed surface and trenches of the Death Stars. The film earned a Special Achievement Award for Visual Effects at the 56th Academy Awards®.

Crafted by ILM, this tower is made of cast resin painted matte grey with select panel sections given additional dark grey, brown, and white highlights. The bottom of the tower is hollow and the turret at the top features two small grey gun barrels. The tower exhibits some signs of wear from use and age, including having undergone sympathetic restoration to reattach the gun barrels after they were previously broken off. Dimensions: 4 cm x 4 cm x 12.25 cm (1.5" x 1.5" x 4.75")

**Estimate: £15,000 - 30,000**



110 cm (43.5")



Includes a Futaba T6EXA transmitter RC controller

**379**  
**Remote-controlled Light-up**  
**R2-D2 Replica τΔ**  
**Star Wars: A New Hope (1977)**

A remote-controlled, light-up replica R2-D2 droid, constructed by the R2-D2 Builders' Club, a group of Star Wars fans dedicated to building replica R2-D2 droids, who went on to provide and oversee the R2-D2 model for Star Wars: The Force Awakens.

The model is life-size and made entirely of aluminium, with each foot housing a 24v 100W scooter motor, a rotating dome, and light effects powered by battery. The back panel can be removed for access to the electronics, and the droid can be driven via remote control, with two controllers included.

Unlike many commercially available R2-D2 replicas, this one has a dome made of aluminium rather than fibreglass, like the Artoo model used during the filming of Star Wars: A New Hope. It was also created in accordance with the Builders Club's R2.0 plans; droids made with reference to these are generally considered the best fan-built Artoo models. The droid is hand-painted, and is intentionally distressed to be as screen-accurate as possible. Dimensions: 110 cm x 75 cm x 70 cm (43.5" x 29.5" x 27.5")

Special shipping required; see special shipping notice in the Buyer's Guide.

Contains electronics; see electronics notice in the Buyer's Guide.

**Estimate: £20,000 - 40,000**

Dome and body are made of aluminium





**380**  
**Promotional DNA Productions**  
**Darth Vader Tour Costume M**  
**Star Wars: Original Trilogy (1977-1983)**

A Darth Vader touring costume used to promote the release of George Lucas' Star Wars Trilogy on videotape. The promotional costume was crafted by former LucasFilm archivist Don Bies and his wife Anna of DNA Productions in 1995 for distributor Fox Studios.

The costume comprises a vacuum-formed plastic helmet and fibreglass mask; a stretch fabric collar; a full-length cape and under-robe; vacuum-formed plastic chest armour with attached pauldrons; a fibreglass chest control box; a tunic featuring faux leather sleeves; a pair of gloves; a leather belt featuring three control boxes; a padded leather codpiece; a pair of faux leather trousers; and a pair of leather boots with attached plastic shin guards.

Each glove has a DNA Productions label sewn into its interior with "#7" handwritten in blue ink. Clipped onto the belt's left side is a cast resin lightsaber, based on a casting of the "Energizer Bunny" lightsaber used in the infamous 1994 Energizer commercial. The chest and belt boxes contain internal electronics that illuminate various buttons, including three red lights on the chest, which light up in sequence. One belt box contains a circuit board that once projected the Sith Lord's breath sounds. The electronics were designed and built by former ILM model maker and Mythbuster Grant Imahara.

There are signs of wear and age, with some minor damage present on the mask. The costume comes presented on a custom-made mannequin and is supplied with an external 12V power supply. This is believed to be the first example of this style of touring costume to come to auction. Dimensions (displayed): 37 cm x 69 cm x 209 cm (14.5" x 27.25" x 82.25")

Special shipping required; see special shipping notice in the Buyer's Guide.

Contains electronics; see electronics notice in the Buyer's Guide.

**Estimate: £25,000 - 50,000**



209 cm (82.25")



Lightsaber was resin casted from the "Energizer Bunny" lightsaber used in the classic 1994 Energizer commercial.



Belt box contains a circuit board that once projected Vader's breathing sound



Each glove has a "© 1995 LFL DNA Productions" label sewn into the interior with "#7" handwritten in blue ink







**381**  
 Mark Hamill, Harrison Ford and Cast-autographed  
 Imperial Stormtrooper Helmet Replica Ω  
**Star Wars: A New Hope (1977)**

A cast-autographed replica of an Imperial Stormtrooper helmet from George Lucas' Star Wars: A New Hope.

This helmet was produced by EFX Collectibles under the official licence of Lucasfilm Ltd. It is autographed in black marker pen by Mark Hamill (Luke Skywalker), Harrison Ford (Han Solo), Anthony Daniels (C-3PO), Peter Mayhew (Chewbacca), David Prowse (Darth Vader), Ian McDiarmid (Emperor Palpatine), Tim Rose (Admiral Ackbar), Mark Dodson (Salacious Crumb) and Mike Quinn (multiple roles).

The lot is accompanied by a certificate of authenticity card for each of the signees. Each card features a picture of the signee autographing the helmet. The original certificate of authenticity from EFX is also included, as is the original packaging. Dimensions: 29.5 cm x 31 cm x 28.5 cm (11.5" x 12.25" x 11.25")

The autographs in this lot have been professionally authenticated by expert Garry King; see notice in the Buyer's Guide.

**Estimate: £5,000 - 10,000**

**382**  
 Light-up Master Replicas Signature  
 Edition Millennium Falcon Ω  
**Star Wars:  
 The Empire Strikes Back (1980)**

A Master Replicas Signature Edition studio-scale replica of the Millennium Falcon from Irvin Kershner's Star Wars: The Empire Strikes Back. Released in October 2006, this limited, Signature Edition model was based on the 32" Millennium Falcon filming miniature from the Lucasfilm Archives.

The high-quality resin model features a machined aluminium internal armature. Many parts are reproduced from injection-moulded plastic to ensure intricate detail, and the radar dish is detachable. The cockpit, headlights and engine lights illuminate via a switch, and an external power supply is included.

The lot is accompanied by a plaque identifying it as number 258 of 500 and is hand-signed by Harrison Ford (Han Solo). Also included are an additional "Corellian Engineering Corporation" plaque, instructions and a detailed booklet, which includes a certificate of authenticity. Dimensions (displayed): 91.5 cm x 66.5 cm x 32 cm (36" x 26.25" x 12.5")

Contains electronics; see electronics notice in the Buyer's Guide.

**Estimate: £6,000 - 12,000**



91.5 cm (36")



Includes unique # 258/500 hand-signed plaque by Harrison Ford along with the original Master Replicas certificate of authenticity



Numbered base plate  
 426 of 500

**383**  
 Yoda Skin Reproduction Display Derived from  
 Original Puppet Moulds with Nick Maley Autographs Ω  
**Star Wars: The Empire Strikes Back (1980)**

A reproduction of Yoda's skin faithfully reverse-engineered from surviving reference castings from the original moulds of the Yoda puppet created for Irvin Kershner's Star Wars: The Empire Strikes Back. Yoda, the beloved Jedi Master who trained Luke Skywalker (Mark Hamill) on Dagobah, was brought to life with a combination of a puppet sculpted by artist Stuart Freeborn and voice acting by Frank Oz.

This detailed green foam latex skin was created by Nick Maley, the makeup artist responsible for creating the original Yoda moulds under Freeborn. Maley created the foam latex skins, ears, hands, and feet for all versions of the Yoda puppet seen in the film.

This painstakingly reproduced green foam latex head with flexible urethane supports in the forehead and crown comes mounted via a wooden dowel to a resin display stand painted black and filled with sand for structure. Also included are colour-printed photographs of Maley working on the Yoda puppet in 1979, both alone and with his fellow ESB makeup, hair, and creature crew members; Maley with a 2018 reconstruction of the Yoda puppet; Maley with a rebuilt animatronic Yoda in 2020; a print-out of Facebook posts made by Maley during the animatronic's rebuild; and instructions sheets for caring for the display. The first four photographs are autographed in gold-colour marker by Maley.

While it remains supple and exhibits only minor cracking in the ears and on the back of the neck thanks to careful storage, this lot remains delicate and should be handled with caution.

Proceeds from the sale of this lot go to Maley's Follow Your Star Foundation, whose mission is to raise money to uplift endangered children.

Dimensions: 33 cm x 20.5 cm x 33 cm (13" x 8" x 13")

**Estimate: £3,000 - 6,000**



213 cm (84")

**384**  
 Rubie's Life-size Light-up Limited Edition  
 Darth Vader Statue Ω  
**Star Wars: The Empire Strikes Back (1980)**

A light-up full-size, limited edition statue of Darth Vader as seen throughout George Lucas' Star Wars franchise. Released in 1996 by the Rubie's Costume Company as part of a limited edition run of licensed, life-size figures, this statue is numbered 426 of 500.

Rubie's was one of the first companies to produce high-quality costume displays in the 1990s, with some of their creations used for promotional purposes by Lucasfilm around the world. Each statue was hand-crafted by Michael Burnett Studios from original moulds, blueprints, and photos from the Lucasfilm archives.

This statue is made of fibreglass and moulded latex with various plastics, a fabric cape and robe, and metal armature components. It comes mounted to a custom base featuring the Star Wars logo and edition number engraved into an affixed plaque. The statue and its helmet can easily be removed from the stand. It is without its lightsaber. Also included is an adapter power source and two pages of instruction paperwork. Shipping crate included. This lot exhibits some scuffing to the boot and plastic finish, and dimpling in the faux leather. Dimensions: 213 cm x 89 cm x 61 cm (84" x 35" x 24")

Additional Provenance: Star Wars Rubies Certificate of Authenticity.

Special shipping required; see notice in the Buyer's Guide.

Contains electronic components; see notice in the Buyer's Guide.

**Estimate: £5,000 - 10,000**



Photo 12 / Alamy Stock Photo

**385**  
Jar Jar Binks (Ahmed Best)  
Eyeline Reference Head  $\Omega$   
**Star Wars:**  
**The Phantom Menace (1999)**

A Jar Jar Binks (Ahmed Best) eyeline reference head from George Lucas' Star Wars: The Phantom Menace. While the character seen in the final cut of the film was computer generated, actor Ahmed Best performed as Jar Jar on-set during filming, wearing a Jar Jar head on top of his own to give his costars an eyeline to look at.

The Phantom Menace, the first new Star Wars film in 16 years and the first to be directed by Lucas since the original 1977 film, was one of the most highly anticipated films of all time and broke box office records upon release. The film was nominated for three Academy Awards®: Best Sound, Best Sound Effects Editing, and Best Visual Effects.

This eyeline reference, sculpted to appear as the upper half of Jar Jar's head without ears, is constructed primarily of foam painted red-orange and beige with acrylic eyes featuring yellow irises. The bottom of the head is open, as it was meant to be worn like a hat, and the head includes a black stand for display. It exhibits cracking and some paint loss throughout the finish, as well as staining to the foam interior. Dimensions: 30.5 cm x 20.5 cm x 19.25 cm (12" x 8" x 7.5")



30.5 cm (12")



Underside angle showing opening for wearer

**Estimate: £12,000 - 24,000**

**386**  
Qui-Gon Jinn's (Liam Neeson) Duelling Lightsaber  $\Omega$   
**Star Wars: The Phantom Menace (1999)**

Qui-Gon Jinn's (Liam Neeson) duelling lightsaber from George Lucas' Star Wars: The Phantom Menace. The Jedi Master wielded his signature green lightsaber throughout the film, including when he duelled with Sith apprentice Darth Maul (Ray Park) on Tatooine and in Naboo's Theed Palace. Qui-Gon's lightsaber was subsequently used by Obi-Wan Kenobi (Ewan McGregor) to avenge his master, and was also featured on page 12 of David West Reynolds' book Star Wars Episode I: The Visual Dictionary.

Many variations of lightsabers were designed for the film by design director Doug Chiang, with each Jedi having a uniquely crafted lightsaber designed to reflect their personality. Neeson personally picked this design for his character.

This lightsaber consists of a lightweight hilt constructed primarily from resin with ribbed detailing running down to the base, a red static activator switch on one side, and a black and silver-colour paint finish. It is cast around a threaded steel rod protruding through the projection plate for affixing a blade, which would then be digitally overlaid with its signature green glow in post-production.

Also included is an aluminium "blade" (staff) painted green with two metal screws for affixing it to the body. The hilt exhibits flaking paint in multiple places and staining on the rod from production use, while the blade exhibits scuff marks throughout. Dimensions: 124.5 cm x 5 cm x 5 cm (49" x 2" x 2")

**Estimate: £15,000 - 30,000**



124.5 cm (49")



227 cm (89.25")

**387**  
**Darth Maul's (Ray Park) Short-bladed Lightsaber**  $\alpha$   
**Star Wars: The Phantom Menace (1999)**

Darth Maul's (Ray Park) short-bladed lightsaber from George Lucas' Star Wars: The Phantom Menace. Sith Lord Darth Maul wielded his signature double-bladed lightsaber during the climactic fight against Qui-Gon Jinn (Liam Neeson) and Obi-Wan Kenobi (Ewan McGregor) in Theed Palace on Naboo.

Darth Maul was skilled in the ways of the dark side, creating his double-bladed saberstaff as his signature weapon. Although his lightsaber was first seen on screen in The Phantom Menace, it originated in the comic-book series Star Wars: Tales of the Jedi. Short-bladed weapons were created for the filming of action sequences, for which full length blades were too cumbersome.

The Phantom Menace, the first new Star Wars film in 16 years and the first to be directed by Lucas since the original 1977 film, was one of the most highly anticipated films of all time and broke box office records upon release. The film was nominated for three Academy Awards®: Best Sound, Best Sound Effects Editing, and Best Visual Effects.

This lot consists of a resin lightsaber hilt with machined steel end caps cast around M10 threaded rods on each end and an internal steel core for weight and strength, as well as two short aluminium "blades" (staves) painted orange. The threaded rods allowed for quick installation and frequent replacement of the blades as they were damaged during duelling sequences.

The hilt is finished in silver-colour with shades of dark grey to give depth to the detailing throughout, including the two ribbed hand grips and parts of the blade-emitter plate. Metallic red activator buttons and control lock buttons span the hilt's length.

The blades exhibit splotching and discoloration from use and age, the hilt exhibits several small slashes, and the rods exhibit rusting and discoloration from having the blades attached and removed. Dimensions: 227 cm x 10.25 cm x 10.25 cm (89.25" x 4" x 4")

**Estimate: £30,000 - 60,000**



Emitter detail



Photo 12 / Alamy Stock Photo





27 cm (10.75")

**388**

**Mace Windu's (Samuel L. Jackson) Hero Lightsaber** *Star Wars: Attack Of The Clones (2002)*

Mace Windu's (Samuel L. Jackson) hero lightsaber from George Lucas' *Star Wars: Attack of the Clones*. Jedi Master Windu wielded his distinctive purple lightsaber throughout the film, including during his battle with Jango Fett (Temuera Morrison) and the Separatist Droid Army. Jackson famously asked Lucas for a specialised purple lightsaber so Windu could stand out on screen. Despite some initial reluctance, Lucas agreed.

This lightsaber is a hero version which doesn't have a duelling rod extending out of the hilt. This suggests it was designed for close ups and slower-paced scenes, such as council meetings at the Jedi Temple, or while Windu held his lightsaber to Fett's neck on the planet Geonosis.

The lightsaber is crafted in resin and vacuum metalised with a mirror-chrome finish in silver and gold. It features a handle comprising strips of black rubber and two additional rubber sections, each with an intricately lined pattern. Dimensions: 27 cm x 4.5 cm x 4 cm (10.75" x 1.75" x 1.5")

**Estimate: £40,000 - 80,000**



Emitter detail



Pommel cap detail



Everett Collection Inc / Alamy Stock Photo





**389**  
Count Dooku's (Christopher Lee) Stunt Lightsaber with SFX Blade m  
**Star Wars: Revenge Of The Sith (2005)**

Count Dooku's (Christopher Lee) stunt lightsaber from George Lucas' Star Wars: Revenge of the Sith. Sith Lord Dooku wielded his lightsaber to fight the Jedi, and Anakin used Dooku's own lightsaber to behead him.

This lightsaber, made for sequences where Dooku fought the Jedi, comprises a carbon fibre SFX "blade" painted green and wrapped in a clear plastic sheath, and, separately, a resin handgrip inset plated silver with a steel rod, with gold and black painted detailing to simulate a textured metallic finish. The blade screws into the hilt and can be removed; this allowed damaged blades to be replaced during filming. The blade has "Green Good" handwritten on the section which screws into the hilt. The handgrip has some wear from age and use. Most notably, the metallic paints have worn away, revealing the gold-coloured resin beneath. Dimensions: 123.5 cm x 4 cm x 6 cm (48.5" x 1.5" x 2.25")

**Estimate: £30,000 - 60,000**

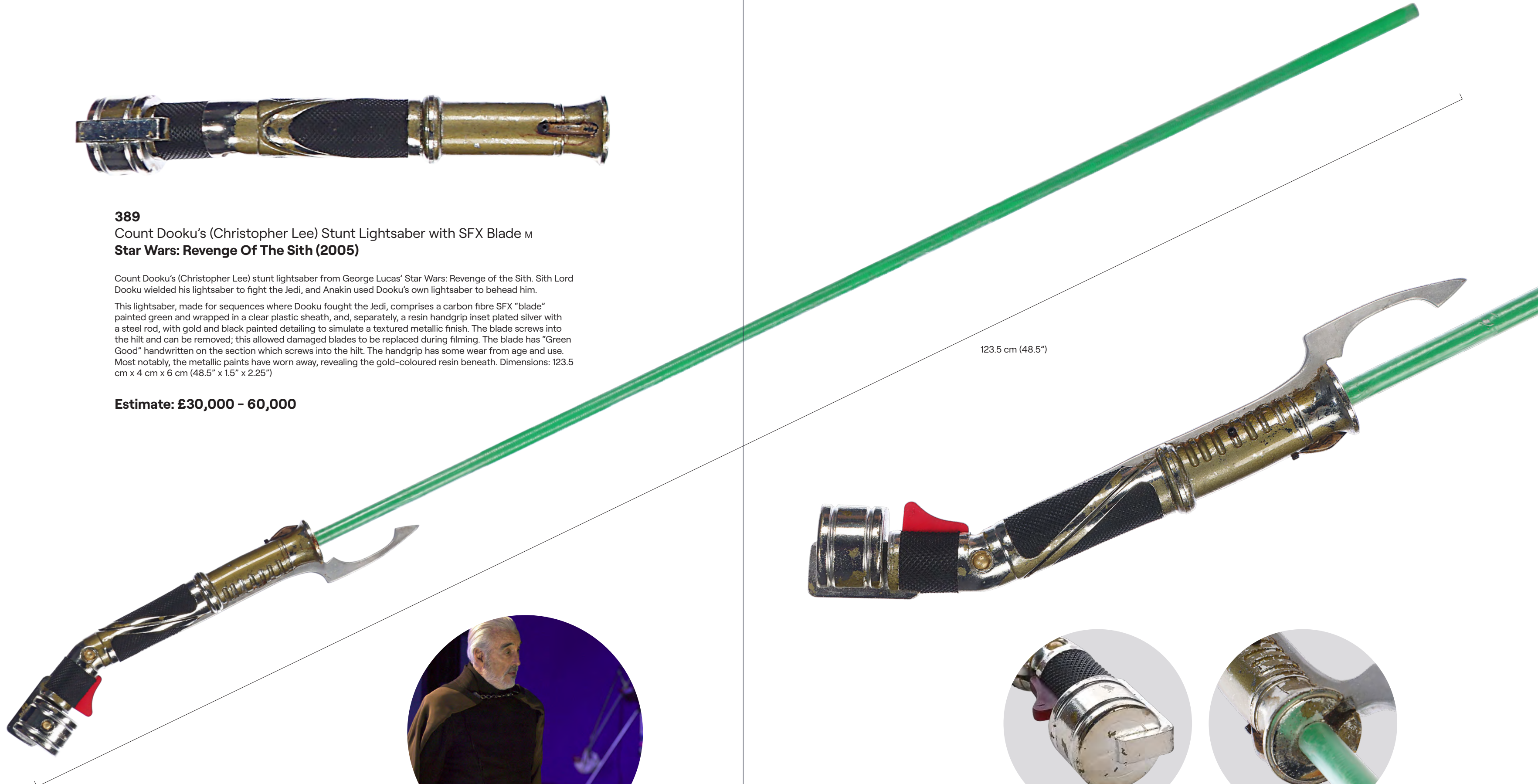

123.5 cm (48.5")

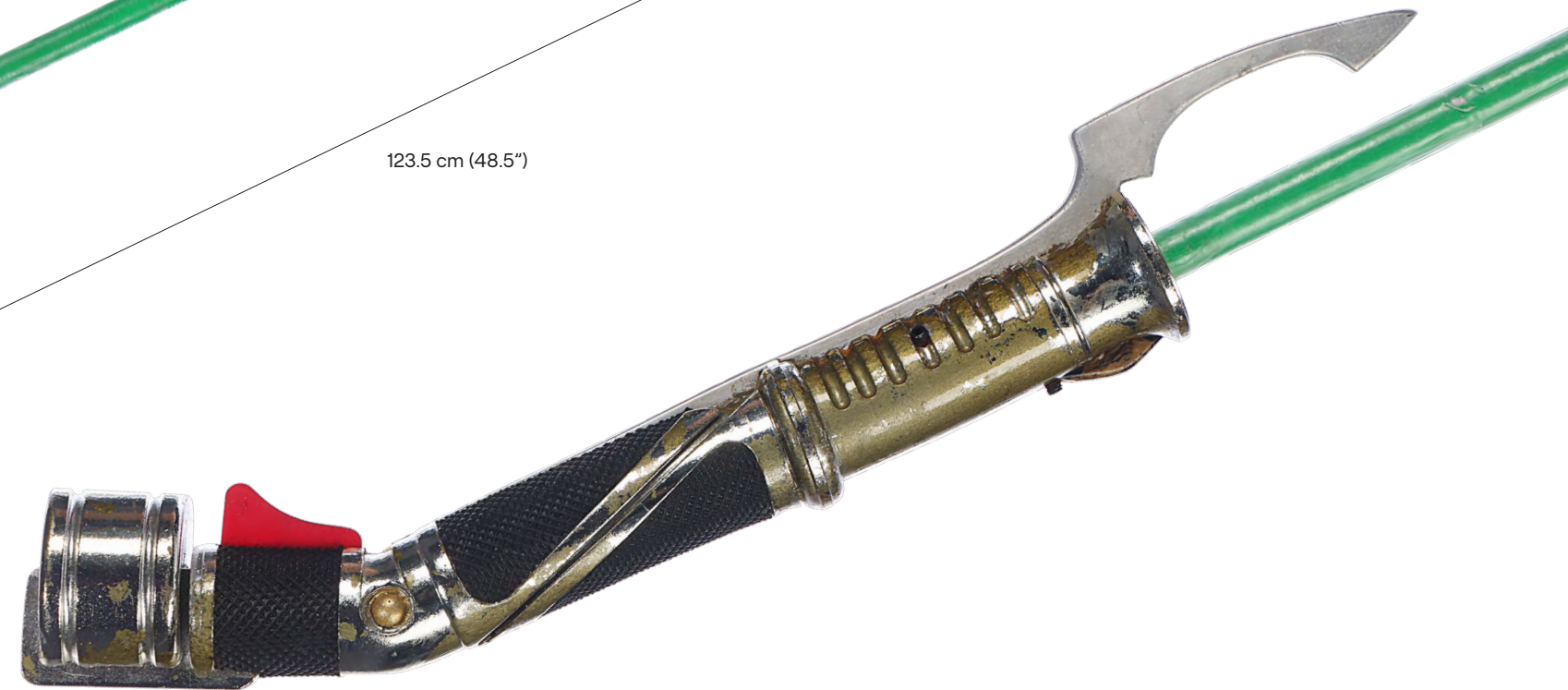

Photo 12  
/ Alamy Stock Photo



Pommel cap detail



Emitter detail



162 cm (63.75")

**390**  
Screen-matched Tantive IV Docking Door Surround m  
**Rogue One: A Star Wars Story (2016)**

A screen-matched Tantive IV docking door surround from Gareth Edwards' *Rogue One: A Star Wars Story*. The Tantive IV was a CR90 corvette which served as Princess Leia's (Carrie Fisher) personal starship. It appeared at the beginning of *Star Wars: A New Hope* and at the end of *Rogue One*, as Rebel soldiers desperately tried to pass the Death Star plans to Leia. This door surround screen-matches the one the soldiers step through before the ship departs, through multiple stains and markings all over.

The surround is made of fibreglass around a wooden structure and is in four separate parts which can be screwed together. It has been intentionally distressed to appear dirtied and well-used. Dimensions: 223 cm x 162 cm x 21 cm (87.75" x 63.75" x 8.25")

Special shipping required; see special shipping notice in the Buyer's Guide.

**Estimate: £5,000 - 10,000**



61.5 cm (24.25")

**391**  
Mark Hamill, Carrie Fisher, Harrison Ford, and Key Cast and Crew-autographed  
Star Wars Celebration Poster m  
**Star Wars: The Complete Saga**

A poster autographed by Mark Hamill, Carrie Fisher, Harrison Ford, and many other members of the cast and crew from across the *Star Wars* saga. This limited edition poster was created for *Star Wars Celebration Europe*, held in London, UK in July 2016. It has been autographed by 29 cast and crew members, including Hamill, Fisher, Ford, Ewan McGregor, Anthony Daniels, Peter Mayhew, David Prowse, Kenny Baker and more. Many of the signatories have written short inscriptions or their character's name. The poster has "23/280" handwritten near the bottom and has some creasing. Dimensions: 81 cm x 61.5 cm (32" x 24.25")

The autographs in this lot have been professionally authenticated by expert Garry King; see notice in the Buyer's Guide.

**Estimate: £3,000 - 6,000**

**392**  
Lamia's (Michelle Pfeiffer) Costume m  
**Stardust (2007)**

Lamia's (Michelle Pfeiffer) costume from Matthew Vaughn's 2007 fantasy adventure film *Stardust*. The evil witch Lamia wore this costume for her meeting with Ditchwater Sal (Melanie Hill).

The costume comprises a heavy opalescent green bustled overskirt with a gold brocade hem; a pair of black velour elbow-length gloves; a gold brocade long-sleeved boned bodice with lace-up detailing on the sleeves, back and bust, and metal details on the sleeves and bust. There is some fraying to the lace details and the skirt's hem, and the colour of the brocade has slightly faded with time.

**Estimate: £5,000 - 10,000**



**393**  
Lamia's (Michelle Pfeiffer)  
Witches' Billhook and Dagger m  
**Stardust (2007)**

Lamia's (Michelle Pfeiffer) witches' billhook and dagger from Matthew Vaughn's 2007 fantasy adventure film *Stardust*. A billhook and dagger were presented to the powerful witch Lamia by her sisters after she consumed the remains of a star's heart to regain her youth. She then used the weapons to kill other fallen stars, and also in an attempt to kill Yvaine (Claire Danes).

Each blade is made of dark-tinted translucent acrylic, with strands of black suede-like fabric wrapped around it to create a padded handle. Dimensions (hatchet): 44 cm x 20 cm x 3 cm (17.5" x 8" x 1")

**Estimate: £3,000 - 6,000**



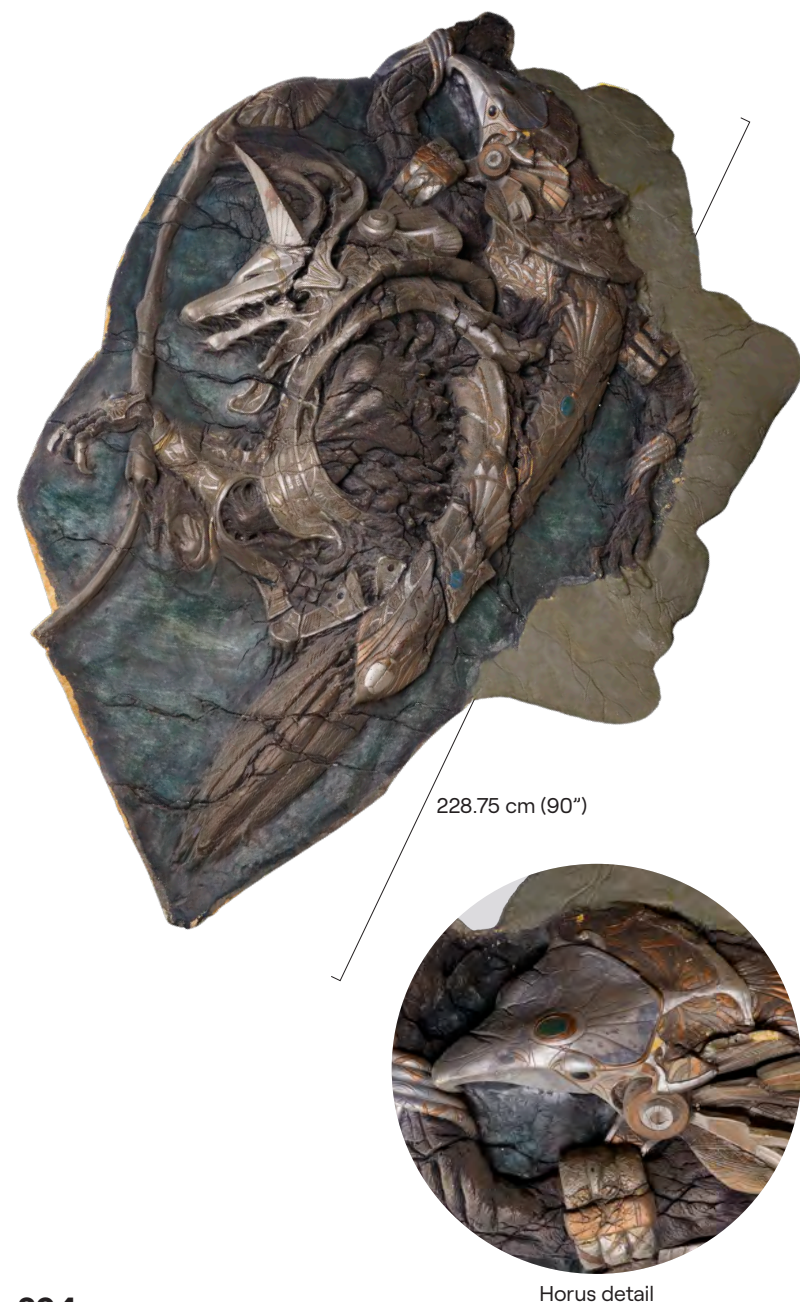

228.75 cm (90")

Horus detail

**394**  
Crushed Anubis and Horus Fossil us  
**Stargate (1994)**

A crushed Anubis and Horus fossil from Roland Emmerich's Stargate. Professor Paul Langford's (Erik Holland) archaeology crew discovered a set of fossils and ruins that his daughter Catherine (Viveca Lindfors) decades later asked Dr. Daniel Jackson (James Spader) to investigate their meaning and origin.

Stargate was nominated for six awards and won six, including a Saturn Award and a Universal Reader's Choice Award for Best Science Fiction Film, and a Golden Screen Award.

This lot consists of a fossil sculpture of Anubis and Horus made of foam painted in various stone-like colours. It exhibits cracked and chipped paint revealing the form beneath. Dimensions: 167.75 cm x 45.75 cm x 228.75 cm (66" x 18" x 90")

Special shipping required; see notice in the Buyer's Guide.

**Estimate: £6,000 - 12,000**



76.25 cm (30")

**395**  
Light-up Screen-matched Mark III Nuclear Warhead Ω  
**Stargate (1994)**

A light-up screen-matched Mark III nuclear warhead from Roland Emmerich's Stargate. Col. Jack O'Neil (Kurt Russell) activated the warhead that would destroy the Stargate within Ra's temple while Dr. Daniel Jackson (James Spader) ensured the Stargate on Earth was destroyed. This warhead screen-matches several scenes throughout the film due to the distinctive nicks and scratches on the detonator activator, warhead, body, and lower base.

Stargate was nominated for six awards and won six, including a Saturn Award® and a Universal Reader's Choice Award® for Best Science Fiction Film, and a Golden Screen Award®.

This lot consists of one warhead made of one faux bomb and a tripod base. Composed of metal, plastic, foam, and resin components, this warhead features a plaque with a decal listing it as "USAF Property" and a "Mark 48 Mod 1" manufactured for "Naval Sea System Command"; a second decal listing a series of numerical information between an A and B column; and a red LED timer. This lot has undergone sympathetic restoration. It exhibits chipped paint, scuffing, and cracks. Dimensions: 76.25 cm x 38.25 cm x 28 cm (30" x 15" x 11")

Contains electronics; see electronics notice in the Buyer's Guide.

**Estimate: £4,000 - 8,000**



Backside of headdress

**396**  
Apophis' (Peter Williams) Screen-matched Headdress Ω  
**Stargate SG-1 (1997-2009)**

Apophis' (Peter Williams) screen-matched headdress from Stargate SG-1. After a year of the Stargate being dormant, a troop of Jaffa accompanied by Apophis appeared through the Stargate and abducted Sgt. Weterings (Rachel Hayward). This headdress matches the premier episode "Children of the Gods" (101) due to the paint and other markings that align with the scenes.

This lot consists of one ornate gold-colour headdress in the shape of a cobra head with decorative Goa'uld markings painted black. Made of rigid biscuit foam on a wire armature and lined with soft foam and black velveteen, this headdress features webbed nylon plastic buckles to secure to the body armour. It has red acrylic eyes shaped with facets to resemble large jewels. This lot exhibits chipped paint on the edges, notable pitting in the foam from the curing process, and raw insides inside the headdress.

**Estimate: £4,000 - 8,000**



Hero pick (resin)



SPX "glow" variant pick (resin)



Crew gift pick (metal)



Belt buckle (metal)



Belt buckle back (metal)  
Inscribed: "Tenacious D"  
"Made in U.S.A." and "P.O.D. 2005"

**397**  
Hero Pick of Destiny, SFX Pick, Crew Pick  
and Belt Buckle M  
**Tenacious D In The Pick Of Destiny (2006)**

A hero Pick of Destiny, an SFX Pick of Destiny, a crew pick and a belt buckle from Liam Lynch's musical comedy Tenacious D in The Pick of Destiny. In the film, JB (Jack Black) and KG (Kyle Gass) sought to steal the magical guitar pick that gave its owners special guitar-playing abilities.

The hero pick is green with black features, while the SFX variant is green without the black detailing, as it was designed to glow in certain scenes. Both picks are made of resin.

The third pick is made of metal and was created as a crew gift, as was the metal belt buckle. All four items depict the Tenacious D ram-skull logo. Dimensions (belt buckle): 2 cm x 6.75 cm x 6.75 cm (0.75" x 2.75" x 2.75")

**Estimate: £5,000 - 10,000**

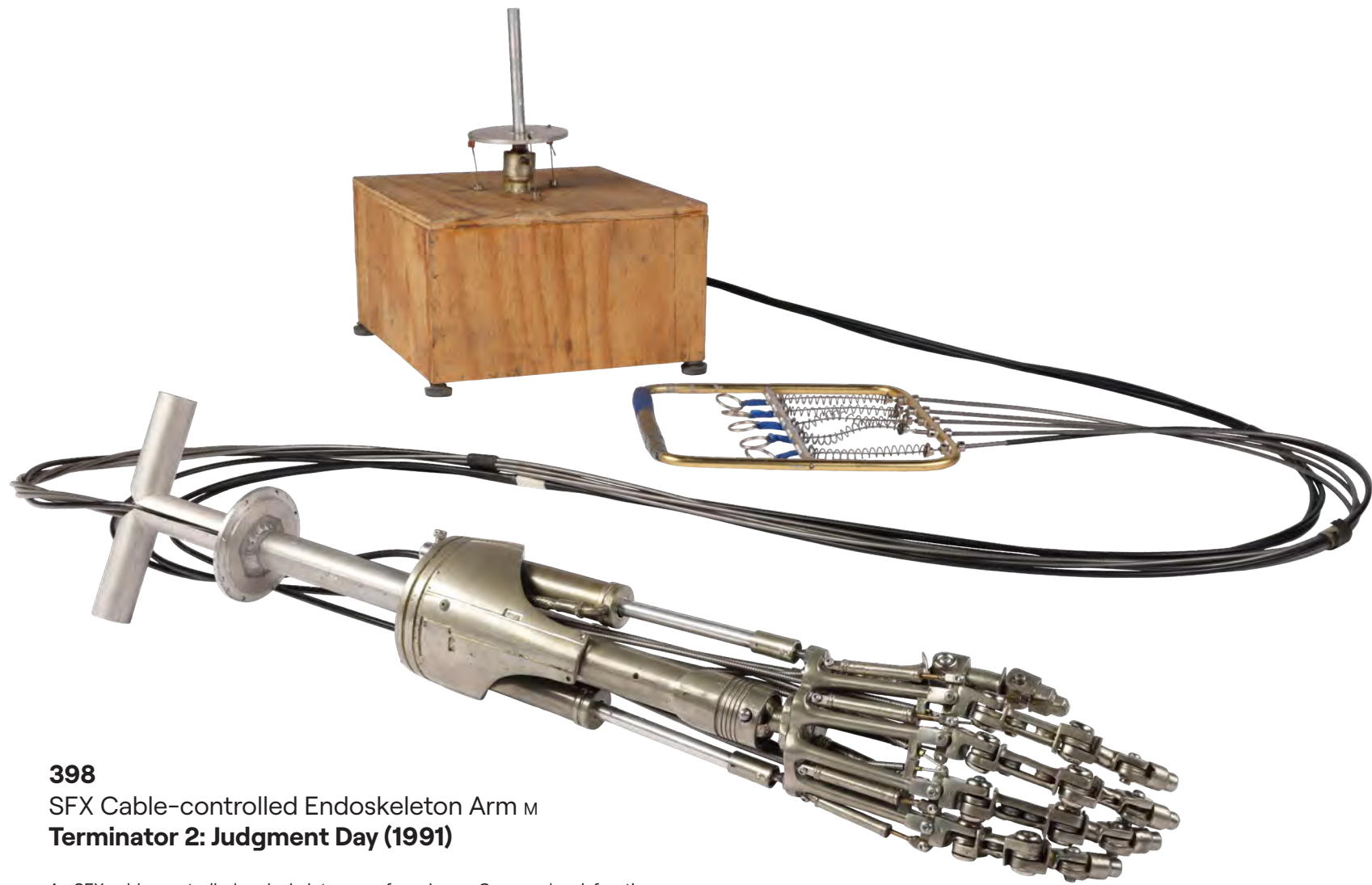

**398**  
**SFX Cable-controlled Endoskeleton Arm m**  
**Terminator 2: Judgment Day (1991)**

An SFX cable-controlled endoskeleton arm from James Cameron's sci-fi action sequel Terminator 2: Judgment Day. The T-800 (Arnold Schwarzenegger) warned Cyberdyne engineer Miles Dyson (Joe Morton) about the future consequences for humanity of the creation of his microprocessor. To convince Dyson, the T-800 removed the skin from his forearm with a knife, revealing the endoskeleton underneath.

The groundbreaking second instalment of the Terminator saga changed cinema forever and won four Oscars in the Best Sound, Best Sound Effects Editing, Best Visual Effects and Best Make-up categories at the 1992 Academy Awards. The latter two awards went to the legendary Stan Winston and his studio, who were responsible for building this endoskeleton arm. Winston has two more Academy Award wins in the Best Visual Effects category for his work on Aliens (1986) and Jurassic Park (1993).

This SFX arm's mechanical features allow the wrist and fingers to move and clench as they do in the aforementioned scene while being operated out of shot - though this is a right arm, whereas the one seen in close up is the left. The impressive amount of effort put into this animatronic, considering it was produced for such a small part of a scene, demonstrates the unprecedented standard of SFX set by Terminator 2. Each finger can be clenched individually or simultaneously with the others via five pin-headed cables that run up the inside of the arm. The wrist also has mobility, controlled by a joystick device connected by cables. These functional features created the miraculous illusion that the arm was lifelike. These mechanisms remain functional.

The arm is made of metal, as are the joystick and pin-headed cables that control the fingers. The joystick is embedded in a small wooden platform, and is connected to the arm via a network of metal and plastic cables. Dimensions (arm): 71 cm x 15.5 cm x 8.5 cm (28" x 6" x 3.25")

Contains mechanical components; see mechanical notice in the Buyer's Guide.

**Estimate: £30,000 - 60,000**



Moviestore Collection Ltd / Alamy Stock Photo

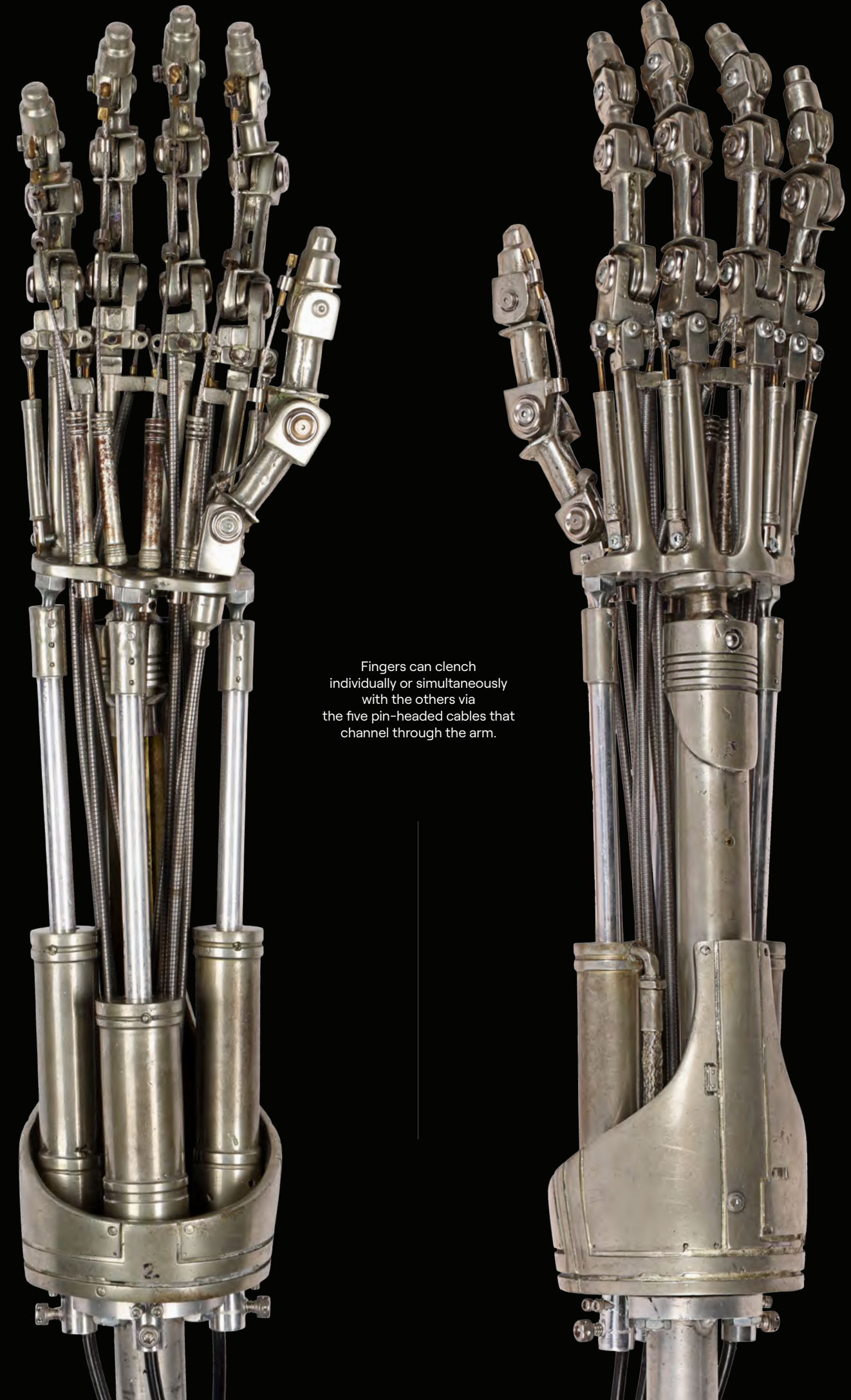

Fingers can clench individually or simultaneously with the others via the five pin-headed cables that channel through the arm.





**399**  
The Terminator's (Arnold Schwarzenegger)  
Hero Colt 1911 Pistol m  
**Terminator 2: Judgment Day (1991)**

"Hasta la vista, baby."  
The Terminator's (Arnold Schwarzenegger) hero Colt 1911 pistol from James Cameron's sci-fi action sequel Terminator 2: Judgment Day. The Terminator wielded his pistol after stealing it from the biker bar. It was also used by Sarah Connor (Linda Hamilton) during her escape from the mental institution, before ultimately being disposed of in the Cyberdyne shoot-out.  
Marked with the serial number "CRM2227", this pistol is a composite weapon formed from parts of a Detonics 1911-style receiver with the barrel, slide and grips from a Colt Government Mk. IV 9mm automatic. The slide and slide release are made from blued steel, while the frame and safety have been given an anodised finish.

The piece has been sympathetically deactivated with functional slide, hammer, safeties, slide release and magazine release. The pistol is supplied with a certificate of deactivation. Dimensions: 22 cm x 3.25 cm x 13.5 cm (8.75" x 1.25" x 5.25")

Restricted ownership; see replica firearm notice in the Buyer's Guide.  
Firearm deactivated; see firearm deactivation notice in the Buyer's Guide.

**Estimate: £10,000 - 20,000**



**400**  
Stan Winston Studios  
Terminator Statue Components for Planet Hollywood m  
**Terminator 2: Judgment Day (1991)**

A collection of components from a promotional statue of the T-800 (Arnold Schwarzenegger) from James Cameron's sci-fi action sequel Terminator 2: Judgment Day, custom-made for the Planet Hollywood restaurant chain. The T-800 suffered extreme battle damage while protecting John Connor (Edward Furlong) from the T-1000 (Robert Patrick).  
Promotional statues were created by Stan Winston Studios utilising original moulds from the production. This lot comprises a silicone Schwarzenegger head; a silicone hand in a glove; a metal endoskeleton chest plate; a resin shotgun; a section of silicone leg skin with endoskeleton break-throughs; a leather jacket with faux bullet wounds; and a faux leather belt. Many of the statue's components reveal the Terminator's metal endoskeleton through flesh wounds and are heavily splattered with faux blood. Dimensions (Terminator head): 26.5 cm x 15 cm x 34 cm (10" x 6" x 13.5")

**Estimate: £5,000 - 10,000**

**401**  
John Connor's (Christian Bale)  
Distressed Leather Jacket Costume m  
**Terminator Salvation (2009)**

John Connor's (Christian Bale) distressed leather jacket costume from McG's Terminator Salvation. Connor wore his jacket while he and the Resistance soldiers attacked a prominent Skynet base.

Terminator Salvation was nominated for 14 awards while winning a Taurus World Stunt Award given to Rick Miller for Best Specialty Stunt and a BMI Film Music Award to Danny Elfman.

This lot consists of one zip-up brown leather jacket lined beige fleece with two shirts, a harness, gloves, a belt with holster, a leather belt, two additional pouches, trousers, and a pair of boots. The jacket features a red band on the arm, as well as "2nd Half Sc 13," "19" and "Sc 198 Connor" hand-marked on the interior in black ink. Also included are four faux C4 blocks and two flares, as well as a production tag labelled "Project Angel" for "John Connor" "Christian Bale" hand-marked "102c - sc 153" with two continuity photograph thumbnails attached. Production intentionally distressed this costume. This lot exhibits some discolouration and frayed fibres.

**Estimate: £5,000 - 10,000**



**402**  
Leatherface's (Dan Yeager) Screen-matched Hero Chainsaw m  
**Texas Chainsaw 3D (2013)**

Leatherface's (Dan Yeager) screen-matched hero chainsaw from John Luessenhop's slasher sequel Texas Chainsaw 3D. Leatherface used chainsaws throughout the film to terrorise Heather (Alexandra Daddario) and her friends. This is the second one he used, and it matches several scenes through distinctive marks on the guide bar.

It is a STIHL petrol-powered chainsaw, which has been repainted and heavily distressed by production, with scuffs, scratches and stage blood along the guide bar and engine. Dimensions: 110 cm x 27 cm x 30 cm (43.25" x 10.75" x 11.75")

Special shipping required; see special shipping notice in the Buyer's Guide.  
Contains mechanical components; see mechanical notice in the Buyer's Guide.

**Estimate: £6,000 - 12,000**





Collection Christophel / Alamy Stock Photo



TCD/Prod DB / Alamy Stock Photo

**403**  
R.J. MacReady's (Kurt Russell) Hat α  
**The Thing (1982)**

R.J. MacReady's (Kurt Russell) hat from John Carpenter's *The Thing*. MacReady wore his signature hat when he had to venture out from the research station into the freezing Antarctic climate.

*The Thing* is widely considered a staple title in the horror genre and has been hugely influential on science-fiction and horror filmmaking. In particular, its rendering of the titular extraterrestrial has been hailed as a touchstone in the history of practical effects, while star Kurt Russell's performance has also been considered among the best of his multiple collaborations with director John Carpenter.

This brown felt hat originated from a credited crew member to whom it was gifted by Russell following production. More recently, the hat was included in the Museum of Pop Culture's (MoPOP) "Scared to Death: The Thrill of Horror Film" exhibit in Seattle, Washington.

The hat features a tall four-dent crown and wide brim with each side bent up, and includes both brown leather and yellow and grey woven cord hat bands, a brown leather sweatband with a size tag reading "7 1/8," and a brown leather chin strap. The hat exhibits some wear from use and age, including small holes, additional warping to the shape, and pilling to the felt.

Additional Provenance: Letter of Authenticity from the family of the crew member gifted the hat by Russell as well as three personal photographs from the family.

**Estimate: £40,000 - 80,000**



30.5 cm (12")

**404**  
Cast and Crew-autographed Poster α  
**The Thing (1982)**

A cast and crew-autographed poster from John Carpenter's *The Thing*. This poster featuring a silhouette of a person wearing a parka with fur-lined hood and an obscured face emanating light was designed and illustrated by Drew Struzan for the theatrical release of the film.

This lot consists of a full colour mini movie poster printed on gloss cardstock. It was autographed by Alan Howarth, David Clennon, Dean Cundey A.S.C., Drew Struzan, Joel Polis, John Carpenter, Keith David, Kurt Russell, Norbert Weisser, Peter Maloney, Richard Masur, Thomas G. Waites, T.K. Carter, and Wilford Brimley in blue and silver-colour ink. It exhibits mild creasing and discolouration on the back. Dimensions: (flat) 30.5 cm x 45.75 cm (12" x 18")

**Estimate: £3,000 - 6,000**

# Sell Your Movie Memorabilia

Achieve world record prices for  
entertainment memorabilia



## Star Wars: Return Of The Jedi (1983)

Anthony Daniels Collection:  
Screen-Matched Light-up C-3PO  
(Anthony Daniels) Head

sold for \$843,750 (£675,000)\*

Reach out for a free appraisal  
and valuation with our specialists



Email: [consign@propstore.com](mailto:consign@propstore.com)  
UK Office: +44 (0) 1494 766485  
US Office: +1 818 727 7829

Scan QR code to visit [propstore.com/props](https://propstore.com/props)

## 405

Hector Hopper Wagon Model m  
**Thomas & Friends**  
(T.V. Series, 1984-2021)

A Hector model from the children's television show Thomas & Friends. Hector (an acronym for "Heavily Engineered Coal Truck On Rails") was a large coal hopper truck who made his first appearance in the Series 11 episode "Hector the Horrid!"

This model has a Perspex hopper with a resin face. The base frame and wheels are aluminium painted black, and Hector's name is displayed on each side of the model in white decals. The lot has some minor paint wear, and there are two pieces of black tape inside the hopper. Dimensions: 42 cm x 9 cm x 13 cm (16.5" x 3.5" x 5")

Estimate: £5,000 - 10,000



## 406

Thomas the Tank  
Engine Model Components m  
**Thomas & Friends**  
(T.V. Series, 1984-2021)

Thomas the Tank Engine model components from the British children's television series Thomas & Friends.

This Perspex model was created for the production and used during the first two series. Between the fourth and fifth series, all the show's models were remade in brass, and this original model was used to make moulds for additional copies of Thomas.

The model is painted in Thomas' iconic blue, red and black paint scheme, and is accompanied by an unattached resin face, produced as reference for Ertl die-cast toys. It features no wheels, wheel arches, buffers, funnel or dome. Some other elements are also missing, and much of the paintwork and detailing has worn away. Dimensions: 22 cm x 8 cm x 10 cm (8.75" x 3.25" x 4")

Estimate: £5,000 - 10,000





**407**  
 "Slim" Puppet M  
**Thunderbirds -**  
**The Martian Invasion (1966)**

A "Slim" puppet from Gerry and Sylvia Anderson's sci-fi adventure series Thunderbirds. The character of Slim appeared in "Martian Invasion", the 24th episode of the first season, as an actor playing a police officer, who is saved from drowning in a cave by International Rescue. The puppet was also used in the fourth episode "Terror in New York City" as an audience member of The Ned Cook Show.

The puppet's head was made by sculptor Terry Curtis and has since been professionally restored. The back of the head is held with magnets and can be removed, revealing the solenoid and eye mechanism within. The interior and removable section are labelled "10A" and "13A" respectively. The head was previously sold in Christie's Fine Toys' auction on 26 October 2004.

The puppet's hands are original to the production, but the screw threads have been replaced. The body and costume, meanwhile, are replicas. The lot comes presented on a custom-made display. Dimensions (on display): 16 cm x 16 cm x 54 cm (6.25" x 6.25" x 21.25")

**Estimate: £20,000 - 40,000**



Raygun fits into belt holster



54 cm (21.25")



Interior head detail reveals the solenoid and eye mechanism



**408**  
 Crablogger/Ambulance Model Miniature M  
**Thunderbirds (1965-1966)/**  
**Captain Scarlet And The Mysterons (1967-1968)**

A Crablogger model miniature from Gerry and Sylvia Anderson's sci-fi adventure series Thunderbirds, which was converted into an ambulance for their subsequent series Captain Scarlet and the Mysterons.

A Crablogger forest-clearance vehicle was seen throughout "Path of Destruction", the second episode of Thunderbirds' second season.

Designed and created by supervising special effects director Derek Meddings and his team, this miniature is predominantly constructed from jelutong wood. It has metal features such as wheel alloys and window frames, while the windows are Perspex. Lights are found at the front and rear, and rubber wheels are connected to the miniature's metal suspension system, which is cushioned by foam and was therefore able to bounce slightly, enhancing the realism of the vehicle's movement on screen. A hole in the base of the miniature was previously fitted with a Jetex motor to simulate the movement of dust around the vehicle as it travelled.

The miniature was converted into an ambulance for "Winged Assassin", the second episode of Captain Scarlet and the Mysterons. The ambulance transported Captain Scarlet from a crash site to a hospital before being used again in the 21st episode, "Treble Cross". The ambulance was created by simply cladding the Crablogger with wooden panels. The original Crablogger remains intact beneath these panels. The miniature's electrical components are untested. One bulb is missing, and it also exhibits chips and markings from production-use and age. Dimensions: 65 cm x 20 cm x 23.5 cm (25.5" x 7.75" x 9.25")

Contains electronics; see electronics notice in the Buyer's Guide.

**Estimate: £20,000 - 40,000**



65 cm (25.5")

Underside of vehicle miniature





165.25 cm (65")

**409**  
RMS Titanic's First Class Lounge Window us  
**Titanic (1997)**

RMS Titanic's First Class lounge window from James Cameron's Titanic. Intricate glass windows lined the lounge areas and grand rooms of the First Class areas where Rose Dewitt Bukater (Kate Winslet) felt her life was chosen for her.

Titanic won various awards and accolades, including 11 Academy Awards®, most notably for Best Director to James Cameron and Best Original Song to James Horner and Will Jennings for "My Heart Will Go On."

Originating as one of three windows from the film set in Rosarito, Mexico, this window is made of two glass panels - one featuring a bevelled hexagon design - set between a brown painted wooden frame. This window exhibits minor cracks to the wood. Dimensions: 105.5 cm x 18 cm 165.25 cm (41.5" x 7" x 65")

Special shipping required; see notice in the Buyer's Guide.

**Estimate: £8,000 - 16,000**



**410**  
Rose Dewitt Bukater's (Kate Winslet)  
Printed Farewell Note Ω  
**Titanic (1997)**

Rose Dewitt Bukater's (Kate Winslet) printed farewell note from James Cameron's Titanic. Rose left a brief letter to her fiance Cal Hockley (Billy Zane), shortly after Jack (Leonardo DiCaprio) drew her portrait. Cal later discovered the note, along with Rose's nude portrait.

Titanic won many important awards, most notably with its Academy Awards® for Best Picture and Best Music Original Score for James Horner's compositions. On top of being among the most successful films ever made, it is also often noted as one of the best with regular rankings on lists of films from the 20th century.

The note is printed to appear handwritten on custom, Classic Linen paper-backed RMS Titanic stationery with a red White Star Line flag printed on the left corner above Rose's note, which reads: "Darling now you can keep us both locked in your safe - Rose." This letter exhibits minor grime. Dimensions: 23.5 cm x 17 cm (9.25" x 6.75")

Additional Provenance: Certificate of Authenticity from 20th Century Fox, which notes that the letter was "Placed in Cal's safe with Jack's portrait of Rose."

**Estimate: £6,000 - 12,000**



34 cm (13.5")

**411**  
S.S. Titanic Signage m  
**Titanic (1997)**

"S. S. Titanic" lifeboat signage from James Cameron's romantic disaster film Titanic. Titanic signs were affixed to the luxury ocean liner's lifeboats, used by passengers after it struck an iceberg and began to sink.

The sign is made of resin and painted white with black raised lettering, which reads "S. S. Titanic". Aside from some minor paint damage, it remains in excellent condition. Dimensions: 34 cm x 4.5 cm x 1 cm (13.5" x 1.75" x 0.5")

**Estimate: £3,000 - 6,000**

**412**  
Jack Dawson's (Leonardo DiCaprio)  
Mirror-image Printed  
Third-class Ticket m  
**Titanic (1997)**

Jack Dawson's (Leonardo DiCaprio) mirror-image printed third-class ticket from James Cameron's romantic disaster film Titanic. Jack Dawson (Leonardo DiCaprio) won his third-class ticket in a poker game with Sven Gunderson (Dan Pettersson), whose passenger name appears on the ticket.

As Cameron's replica of the RMS Titanic comprised only the ship's starboard side, he had to reverse any images of it docked at Southampton because in reality, the liner took on its passengers from the port side. As a result, this ticket, like many of the ship's signs and notices, had to be mirror-printed.

The ticket is mounted in a framed display featuring the film's title printed on a brass plaque. It comes packaged in a cardboard box with "Titanic" printed tape wrapped around it. Accompanying the lot is a 20th Century Fox certificate of authenticity, which notes that the ticket was "Won by Jack in on-shore gambling scene". Dimensions: 29 cm x 26 cm x 1.5 cm (11.5" x 10.25" x 0.5")

**Estimate: £3,000 - 6,000**





**413**  
 Pair of White Star Line Sweaters  $\Omega$   
**Titanic (1997)**

A pair of White Star Line sweaters from James Cameron's Titanic. Crew members of the White Star Line wore sweaters as they assisted passengers on board the Titanic and as they kept passengers calm when they helped them evacuate the ship while it sank.

This lot consists of two navy blue wool Angels & Bermans The Costumers to the Entertainment Industry sweaters featuring "WHITE STAR LINE" embroidered in grey on the front. These sweaters are marked "7015" and "44" 118 cm." This lot exhibits minor loose threads.

**Estimate: £3,000 - 6,000**



15 cm (6")



**414**  
 Lara Croft's (Angelina Jolie)  
 Motorcycle Costume  
 and Pair of Pistols  $\dagger$   
**Lara Croft: Tomb Raider (2001)**

Lara Croft's (Angelina Jolie) motorcycle costume and pair of pistols from Simon West's action-adventure Lara Croft: Tomb Raider. Croft wore her black motorcycle leathers at the auction house when she visited her old friend Wilson (Leslie Phillips) for information about the mysterious clock device and she carried her pistols as her primary weapons throughout the film.

The custom-made costume consists of a black leather zip-up jacket and black leather trousers. The jacket features shoulder and elbow padding, with adjustable zips at the end of either sleeve. The trousers are fastened at the front by leather laces. The garment has padded knees, black metal decorative studs, and adjustable zips at the end of each leg.

The stunt firearms are cast from real H&K USP Match pistols and made of hard rubber with a metal armature within. One features a custom ambidextrous magazine release. They are finished in two-tone black and faux-silver paint, accompanied by two rubber magazines, and carried in a leather belt rig featuring custom-made pistol holsters with thigh straps and a leather belt. A replica "Death's head" belt buckle has been added to complete the set. There is some corrosion to the brass belt hardware and wear to the paint finish on the pistols and magazines.

Restricted ownership; see replica firearm notice in the Buyer's Guide.

**Estimate: £6,000 - 12,000**

**415**  
 Luna Temple Orb  $\mathfrak{M}$   
**Lara Croft: Tomb Raider - The Cradle Of Life (2003)**

A Luna Temple orb from Jan de Bont's action-adventure sequel Lara Croft Tomb Raider: The Cradle of Life.

The orb was acquired from an ancient Greek temple and appeared throughout, including during the Chinese lab shoot-out, the scene where it was held by Terry Sheridan (Gerard Butler) on the ship, and the Chinese apartment scene where Lara Croft (Angelina Jolie) showed it to Bryce (Noah Taylor) via webcam. Lara also used the Orb during the African crater scenes.

Made of translucent amber resin, the spherical Luna Temple orb has several lines and circular marks, some of which are embossed, while others are pitted. The interior of the orb contains reflective materials which enhance its enigmatic appearance. A hole leads to the middle of the orb, likely designed as a location for a light that would have illuminated it during filming. Dimensions: 15 cm x 15 cm x 15 cm (6" x 6" x 6")

**Estimate: £3,000 - 6,000**



**416**  
 Lara Croft Stunt Costume and Stunt Pick Axe  $\Omega$   
**Tomb Raider (2018)**

A Lara Croft stunt costume and stunt pick axe from Roar Uthaug's action-adventure film Tomb Raider. Lara Croft (Alicia Vikander) wore her costume throughout the film as she explored the island of Yamatai, where her father had gone missing decades before. The costume was for Vikander's stunt double Fleur van Eeden and comprises a vest, undervest, green combat trousers, a leather belt, a pair of black leather boots, and three fabric wraps. The costume is intentionally distressed with stage blood, dirt and cuts.

The pick axe is made of rubber with a cotton wrap around the grip. The tip of the axe is no longer present.

The lot is accompanied by several production tags and two certificates of authenticity from MGM Studios. Dimensions (pick axe): 49 cm x 15 cm x 2.5 cm (19.25" x 6" x 1")

**Estimate: £2,000 - 4,000**



**417**  
 Lieutenant Reuben "Payback" Fitch's (Jay Ellis) Helmet  $\Omega$   
**Top Gun: Maverick (2022)**

Lieutenant Reuben "Payback" Fitch's (Jay Ellis) helmet from Joseph Kosinski's Top Gun: Maverick. Thirty years after his Top Gun graduation, Captain Pete "Maverick" Mitchell (Tom Cruise) returned to Top Gun to teach a class of 12 recalled graduates to compile a group of six that was later sent on a mission to eliminate an illegal uranium bunker plant before it became operational. Payback wore his helmet during flight training with his co-pilot Lieutenant Mickey "Fanboy" Garcia (Danny Ramirez) as they tried to shoot Maverick down to avoid the losing cost of 200 push-ups.

Top Gun: Maverick was nominated for six Academy Awards® and won an award for Best Sound. The film was one of the high-grossing films of 2022 and Cruise's highest-grossing film of his career.

This helmet, given away as part of a promotional contest during the film's release, is made of grey resin coated styrofoam with black and silver-colour vinyl stripes with black foam padding, a black nylon chin strap, and metal latches on the sides to hold an oxygen mask. The left side of the helmet is rigged with a wire to connect the helmet to a communication line. This helmet exhibits peeling vinyl and minor scuff marks.

Contains electronics; see electronics notice in the Buyer's Guide.

**Estimate: £8,000 - 16,000**



Maximum Film  
/ Alamy Stock Photo

**418**  
Sark's (David Warner)  
Screen-matched Helmet m  
**Tron (1982)**

Sark's (David Warner) screen-matched helmet from Steven Lisberger's sci-fi adventure Tron. The merciless program Sark wore his helmet in the neon-tinted digital world of the ENCOM mainframe, where he oversaw the battles fought on the Game Grid.

This helmet matches the one seen on screen by the hood's stitching in its front neck section aligning with its black lines of tape and marker pen. The design of this helmet also matches with what is seen throughout the majority of the film; however, it interestingly features an extra chin bar, which is only seen in Sark's final scene.

A groundbreaking movie, Tron was the first feature to include entirely computer-animated scenes. However, most of its iconic visual effects were created using matte photography techniques and backlit animation. The actors were shot in black-and-white on a black background, then printed on large, high-contrast film and hand-coloured using rotoscoping. This process proved so complicated and costly that it was never again used for a feature film.

This spiked helmet comprises a cream-coloured leather hood with aluminium armour plating attached via strips of Velcro. The black tape and marker pen detailing on the armour and hood indicate where animators would add the glow effect.

Some of the black tape exhibits peeling, while other parts are missing. Dimensions: 31 cm x 22 cm x 50 cm (12.25" x 8.75" x 19.75")

**Estimate: £30,000 - 60,000**





80 cm (32")

**419**  
Achilles' (Brad Pitt) Shield  $\Omega$   
**Troy (2004)**

Achilles' (Brad Pitt) shield from Wolfgang Petersen's Troy. Achilles wielded his signature shield throughout the film, notably using it alongside his sword during the beach battle sequence in which he slaughtered many Trojan soldiers and during his vicious duel with Hector (Eric Bana).

This round shield features two semi-circular cut-outs on opposing sides and features metal panels on the front finished in matte gold-coloured paint to simulate bronze and black decorative plastic panelling around the whole shield designed to resemble hammered metal. The face of the shield features intricate figures at war around the centre, with eight discs situated above them. A strip of thick black leather binds four faux-gold rings attached to the inverse side of the shield. Additionally, the back of the shield exhibits screw holes and square-markings. Also included are two colour-printed photographs, one a screenshot from the film and the other from behind-the-scenes. This lot exhibits discoloration, scuffed paint, chipped and flaked paint, lifted adhesive. Dimensions: 80 cm x 77.5 cm x 10.25 cm (32" x 32" x 4.25")

**Estimate: £15,000 - 30,000**



Moviestore Collection Ltd / Alamy Stock Photo



**420**  
Achilles' (Brad Pitt) Metal Sword  $\Omega$   
**Troy (2004)**

Achilles' (Brad Pitt) metal sword from Wolfgang Petersen's Troy. Achilles wielded his sword throughout the film, using it to brutal effect during his efficient despatch of Boagrius (Nathan Jones) in the opening scene, as well as in his battles against the Trojan Apollonians, and the vicious duel with Hector (Eric Bana).

Made of metal, this custom Greek xiphos sword consists of a curved blade painted a matte gold-colour to replicate with decorative engravings and no guard. Finished in black paint, the grip follows the organic curve of the blade and has two parallel sets of holes also painted the gold-colour to create the illusion of rivets on the grip. Green paint has been added to create the appearance of verdigris. The weapon exhibits paint wear, scratching on the blade, and bending to the tip. Dimensions: 71.5 cm x 10.25 cm x 4 cm (28" x 4" x 2")

Blade was dulled by production.

Edged, bladed or blunt object; see notice on Blades in the Buyer's Guide.

**Estimate: £12,000 - 24,000**



71.5 cm (28")





Interior hand-marked "Brad # 2"



**421**  
Achilles' (Brad Pitt) Lightweight Helmet α  
**Troy (2004)**

Achilles' (Brad Pitt) lightweight helmet from Wolfgang Petersen's Troy. The fabled Greek warrior wore his signature helmet while battling with his fellow Myrmidons on the beaches of Troy.

Legendary Academy Award®-nominated costume designer Bob Ringwood created Achilles' look, and this helmet was specially made to fit Pitt's head. It was also unique to Achilles, clearly marking him out on the battlefield, so much so that Hector (Eric Bana) thought he had slain Achilles, only to find it was Patroclus (Garrett Hedlund) wearing Achilles' armour and helm.

This black plastic lightweight helmet features a distinctive crest across the crown with a black synthetic horse hair plume. The interior is lined with foam and brown suede, which is hand-marked "Brad No. 2" in black at the back. Production intentionally distressed this helmet so it resembled hammered metal, and it is believed to have been refinished for use in a subsequent production. Also included is a colour-printed screenshot from the film and two pages of production paperwork pertaining to filming schedule. This lot exhibits flaked and chipped paint, foam remnants, and lifted adhesive.

**Estimate: £8,000 - 16,000**



**422**  
Clapperboard m  
**Troy (2004)**

A clapperboard from the production of Wolfgang Petersen's historical epic Troy. This clapperboard was used by the production's second unit, and features the names of director, Simon Crane, and director of photography, Fraser Taggart, carved into its acrylic slate. Handwritten in black marker pen are several details from its last use, including scene number, slate number, take, frames per second figures and date of filming. Dimensions: 25 cm x 28 cm x 4 cm (9.75" x 11" x 1.5")

**Estimate: £3,000 - 6,000**



STUDIOCANAL FILMS LTD / Alamy Stock Photo



**423**  
Lord Summerisle's (Christopher Lee) Screen-matched Jacket m  
**The Wicker Man (1973)**

Lord Summerisle's (Christopher Lee) screen-matched Jacket from Robin Hardy's folk horror The Wicker Man. Lord Summerisle wore his jacket throughout the film, and this one matches the one seen during the climactic sacrificial scene, through the stitching and the precise alignment of its patterns.

Interestingly, this garment was one of Lee's favourite jackets. He wore it in several other films, including The Skull (1965), as well as for publicity photos and interviews from the 1960s until his death in 2015.

The jacket is made of tweed with a nylon inner lining, and features "C. Lee" handwritten in black ink on a label stitched into the inside pocket. It also has suede elbow patches; previously, there was a patch on the right shoulder, too, but this was removed after production.

**Estimate: £10,000 - 20,000**



**424**  
Four Rusty Goffe Hand-annotated Oompa Loompa Rehearsal Music Sheets m  
**Willy Wonka And The Chocolate Factory (1971)**

A set of four Rusty Goffe hand-annotated Oompa Loompa rehearsal music sheets from the production of Mel Stuart's family musical Willy Wonka & the Chocolate Factory.

These sheets, obtained directly from Goffe, feature the classic music and lyrics composed by Leslie Bricusse and Anthony Newley, specifically the songs performed by the Oompa Loompas whenever a child made their absurd exit from Willy Wonka's (Gene Wilder) chocolate-factory tour. Sheet one presents Augustus Gloop's (Michael Bollner) song; sheet two Veruca Salt's (Julie Dawn Cole); sheet three Violet Beauregarde's (Denise Nickerson); and sheet four Mike Teevee's (Paris Themmen). The songs all follow the same iconic Oompa Loompa tune, with lyrics altered to reference the relevant character.

Each sheet features the name of Oompa Loompa performer Rusty Goffe, with handwritten annotations in blue ink and Goffe's parts marked. Interestingly, some lyrics have been struck through and replaced in black ink.

Willy Wonka & the Chocolate Factory was Goffe's first feature film, and he has since gone on to make multiple appearances in both the Star Wars and Harry Potter franchises. Dimensions (one sheet): 30.25 cm x 21.25 cm (12" x 8.5")

**Estimate: £5,000 - 10,000**

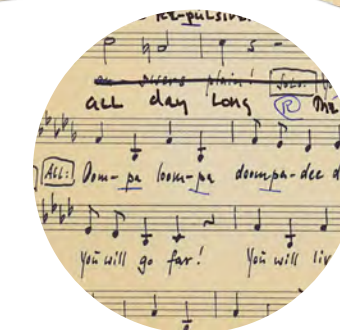

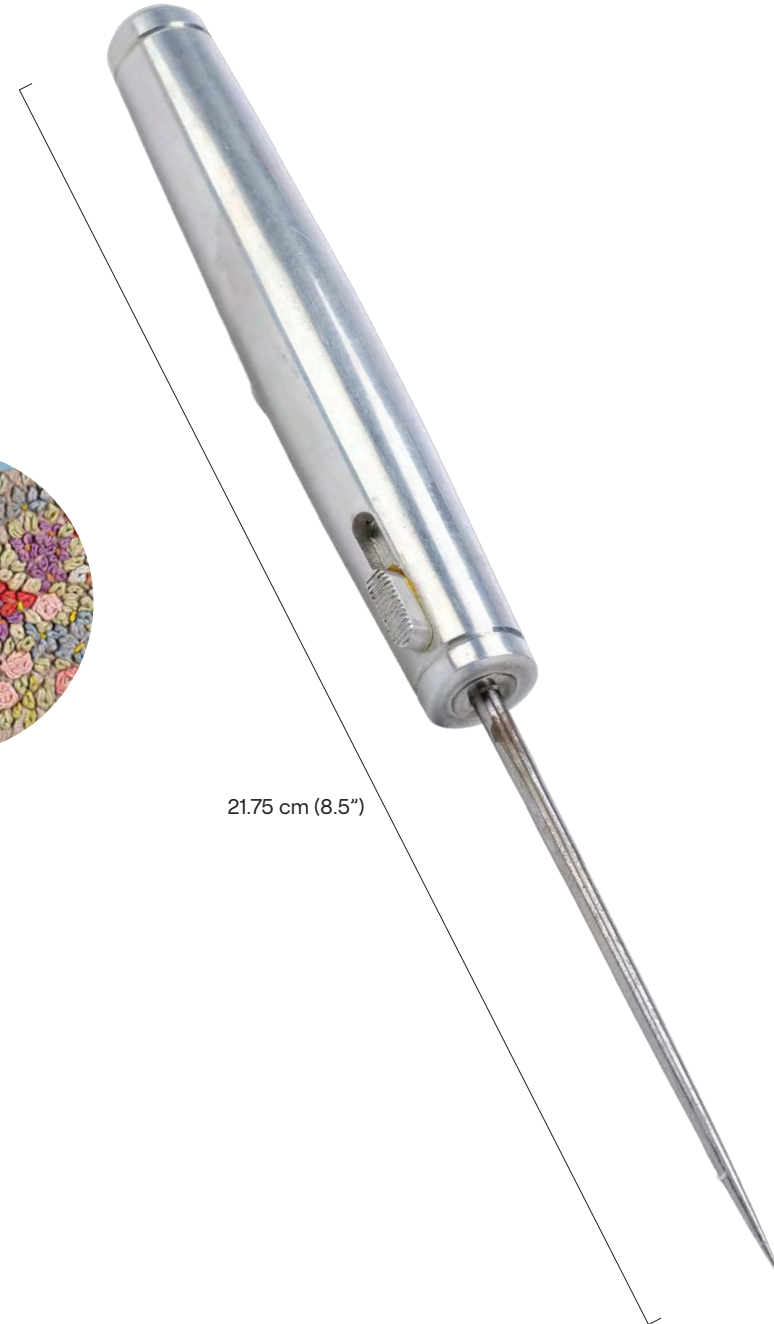
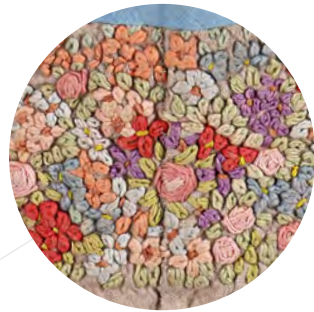

21.75 cm (8.5")

**425**  
Marwood's (Paul McGann) Screen-matched Apron from *Withnail & I* (1987)

Marwood's (Paul McGann) screen-matched apron from Bruce Robinson's cult comedy *Withnail & I*. Uncle Monty (Richard Griffiths) flirted with Marwood as he put an apron on him, while they were together in the kitchen of Monty's country cottage.

The precise alignment of its distinctive floral-patterned stitching screen-matches this linen apron to the one in the scene. The apron exhibits minor brown staining on its waist straps.

**Estimate: £3,000 - 6,000**

**426**  
Alien Bounty Hunter's (Brian Thompson) Gimlet from *The X-Files* (T.V. Series, 1993-2002)

Alien Bounty Hunter's (Brian Thompson) Gimlet from *The X-Files*. The Alien Bounty Hunter used his Gimlet - also known as the "Alien Stiletto," "Alien Switchblade," or "Ice Pick" - throughout the series to kill aliens and hybrids by stabbing the bases of their necks.

Designed under the supervision of property master Ken Hawryliw, this Gimlet first appeared in the Season 2 episode "Colony." It is made from metal with a long, thin spike and a retracting mechanism built into the side. The mechanism and spike exhibit rusting and a pattern engraved on the base has faded from age. Dimensions: 21.75 cm x 2 cm x 2 cm (8.5" x 0.75" x 0.75")

Blade was dulled by production.

**Estimate: £6,000 - 12,000**



38.25 cm (15")

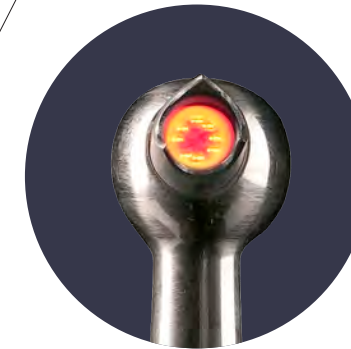

Red LED activated by button on wand shaft

**427**  
Light-up Faceless Alien Incinerator Wand from *The X-Files* (T.V. Series, 1993-2002)

A light-up faceless alien incinerator wand from Chris Carter's *The X-Files*. The faceless aliens used wands like this in Season 5 to start fires.

This lot consists of a light-up wand made of metal in a chrome-colour. The head of the wand features an open side where red LED lights sit, which is activated by a button on the wand's shaft. This wand also features an acrylic cylinder towards the bottom and a circular but static insert. It exhibits a dim red light and scratches on the finish of the wand. Dimensions: 38.25 cm x 5 cm x 5 cm (15" x 2" x 2")

Contains electronics; see electronics notice in the Buyer's Guide.

**Estimate: £4,000 - 8,000**



**428**  
Rogue's (Anna Paquin) Hooded Coat from *X-Men* (2000)

Rogue's (Anna Paquin) hooded coat from Bryan Singer's *X-Men*. Rogue wore her green hooded cloak when she ran away from home and encountered Logan (Hugh Jackman) in Alberta. Later, she also wore the coat as she ran from Xavier's (Patrick Stewart) school after she was tricked by a disguised Mystique (Rebecca Romijn-Stamos).

Won in a sweepstakes for Wherehouse Music in 2002, this double-breasted hooded coat is made of green wool lined with green crepe back satin. It has sleeve straps, a martingale belt, and a single vent. This lot exhibits separated lining on the interior, frayed fibre, and pulled threads.

Additional Provenance: Certificate of Authenticity from Executive Director Alan Adler.

**Estimate: £4,000 - 8,000**



25 cm (10")

**429**

Xena's (Lucy Lawless) Balanced Chakram  
**Xena: Warrior Princess (T.V. Series, 1995-2001)**

Xena's (Lucy Lawless) Balanced Chakram from the fantasy TV series Xena: Warrior Princess. Xena wielded her signature weapon in multiple episodes, and passed the chakram onto Gabrielle (Renee O'Connor) in the Season 6 finale "Friend in Need". The Balanced version was formed by merging the Chakram of Light with the Dark Chakram; the complete weapon resembling the Chinese Yin-Yang symbol.

Made of dense rubber, the throwing weapon's outer edge is finished in faux silver to replicate the appearance of metal. Cast-in texture adorns the central wave design, which has been painted faux bronze and faux gold. The Chakram displays marks and paint wear from production use.

Dimensions: 25 cm x 25 cm x 1 cm (10" x 10" x 0.5")

**Estimate: £4,000 - 8,000**

# Day 2

Lots 430 - 818

November 15, 2024

In-Person Bidding

BAFTA 195 Piccadilly

3:00 PM (GMT) / 7:00 AM (PST)



Music lots can be viewed in the separate Music Treasures printed catalog or in the online catalog.

# Day 3

Lots 819 - 1334

November 16, 2024

Online, Telephone and  
Absentee Bidding Only  
3:00 PM (GMT) / 7:00 AM (PST)

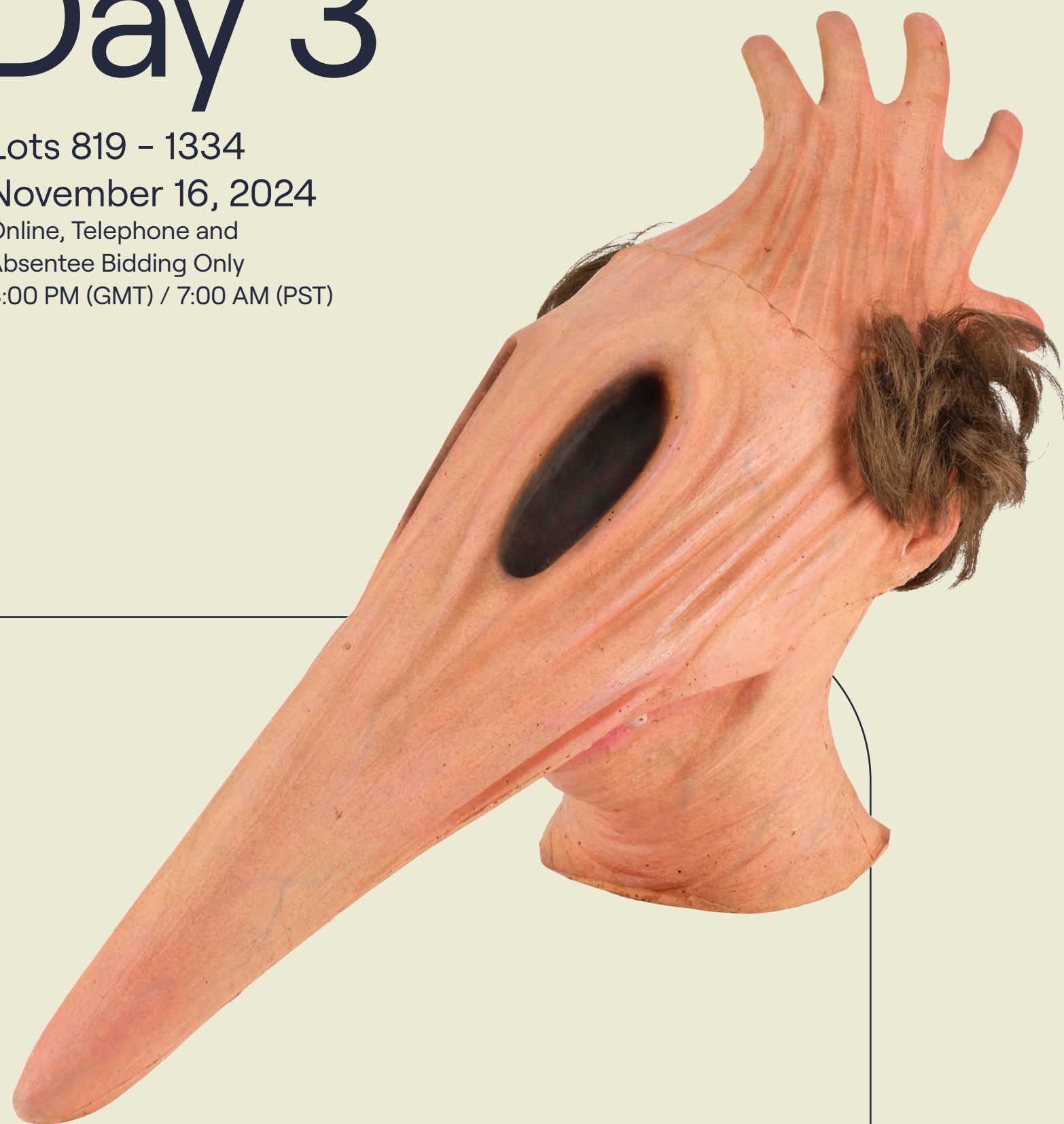

Lots on Days 3 and 4 can be viewed exclusively in the online auction catalog.



**819**  
Buliwuf's (Vladimir Kulich) Bloodied Costume  $\Omega$   
**The 13th Warrior (1999)**

Buliwuf's (Vladimir Kulich) bloodied costume from John McTiernan's *The 13th Warrior*. Buliwuf's Norse costume was bloodied during his final stand against the Wendol warriors and their deadly Mother (Susan Willis). This costume consists of a brown suede overcoat hand-marked "Buliwuf" on the interior; matching trousers with elasticated stirrups at the ankles marked "Buliwuf Sc. 91"; a tan cotton tunic; and a pair of suede lace-up boots marked "Buliwuf #1". The set is bloodied by production and intentionally distressed with grime applied throughout and tears in the upper left shoulders of the overcoat and tunic. The suede exhibits fraying, stiffening, and sticky residue.

**Estimate: £2,000 - 4,000**



**820**  
Keith Hamshere Collection:  
Signed and Hand-numbered Pod  
Bay Set Photographs  $\mathfrak{M}$   
**2001: A Space Odyssey (1968)**

Three signed and hand-numbered pod bay set photographs from the production of Stanley Kubrick's *2001: A Space Odyssey*. The pod bay featured most notably when HAL wouldn't open its doors. This lot comes from the personal collection of renowned stills photographer Keith Hamshere. Hamshere took these photographs of the pod bay set and has hand-signed them in the bottom right corners. He also hand-numbered each photograph - "2r", "1r", and 27 - in the bottom left corner of the card borders. Furthermore, he has hand-numbered them from 155 to 157 on the rear, also in pencil. Dimensions: 34.75 cm x 22.75 cm (13.75" x 9") Sold without copyright; see copyright notice in the Buyer's Guide.

**Estimate: £1,000 - 2,000**



**821**  
Keith Hamshere Collection:  
Collection of Behind-the-Scenes  
Spacesuit Photographs  $\mathfrak{M}$   
**2001: A Space Odyssey (1968)**

A collection of behind-the-scenes photographs of a spacesuit from the production of Stanley Kubrick's sci-fi masterpiece *2001: A Space Odyssey*. This lot comes from the personal collection of renowned stills photographer Keith Hamshere. This lot comprises 10 black-and-white behind-the-scenes photographs of one of the Discovery spacesuits on set, shown from different angles. Two of the photos feature crew members and each image has been signed in the corner by Hamshere. Dimensions (each): 30 cm x 21 cm (11.75" x 8.25") Sold without copyright; see copyright notice in the Buyer's Guide.

**Estimate: £1,000 - 2,000**

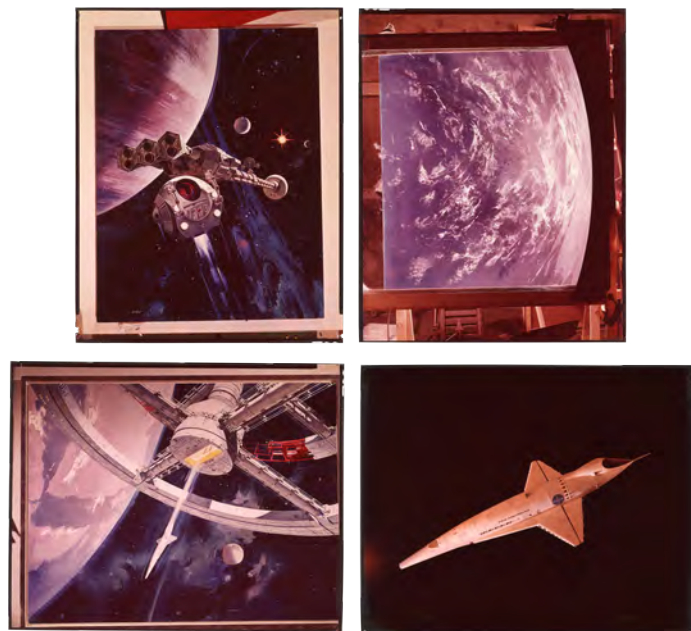

**822**  
Keith Hamshere Collection:  
Four Photographic Transparencies of Robert McCall Poster Art, a Matte Painting and Orion III Model Miniature m  
**2001: A Space Odyssey (1968)**

Photographic transparencies from the production of Stanley Kubrick's 2001: A Space Odyssey. This lot comes from the personal collection of renowned stills photographer Keith Hamshere. Two of the transparencies feature photographs of poster artworks by Robert McCall. One of the artworks - the "Space Station" style - is one of the three most used and recognisable poster artworks. The other poster artwork features Discovery One and its pod, and this style appeared on a British Double Crown during the British poster campaign, and some Italian stills. The matte painting transparency features a planet and the final transparency is a photograph of the Orion III model miniature. Dimensions (each): 25 cm x 20 cm (9.75" x 7.75") Sold without copyright; see copyright notice in the Buyer's Guide.

**Estimate: £1,000 - 2,000**



**823**  
David Frangioni Collection:  
Cinerama 3D Lenticular - Style A, 1968 n  
**2001: A Space Odyssey (1968)**

A scarce lenticular poster for the release of Stanley Kubrick's 2001: A Space Odyssey. It was rare for lenticulars to be produced in the 1960s. MGM and Kubrick wanted to create an advanced advertising campaign that included unique formats, with this lenticular being one of the most impressive pieces. It was produced exclusively for the limited cinemas with Cinerama widescreen format capability. This 10.25" x 13.5" postcard-like example features the Style A design of the "Space-Wheel" imagery created by artist Robert McCall. The lenticular comes presented in its original white-coloured frame and a card standee backing, allowing it to be readily displayed. It remains in near mint condition. Dimensions: 26 cm x 34 cm (10.25" x 13.5")

**Estimate: £2,000 - 4,000**



**824**  
David Frangioni Collection:  
Cinerama 3D Lenticular - Style B, 1968 n  
**2001: A Space Odyssey (1968)**

A scarce lenticular poster for the release of Stanley Kubrick's 2001: A Space Odyssey. It was rare for lenticulars to be produced in the 1960s. MGM and Kubrick wanted to create an advanced advertising campaign that included unique formats, with this lenticular being one of the most impressive pieces created. It was produced exclusively for the limited cinemas with Cinerama widescreen format capability. This 10.25" x 13.5" postcard-like example features the Style B design of the "Man on the Moon" imagery of astronauts working with their equipment and exploring the surface of the Moon by artist Robert McCall. The poster displays some hairline scratches and remains in a very fine condition. Dimensions: 26 cm x 34 cm (10.25" x 13.5")

**Estimate: £2,000 - 4,000**



**825**  
Production Binder n  
**2001: A Space Odyssey (1968)**

A production binder from Stanley Kubrick's 2001: A Space Odyssey. The film garnered numerous awards and Oscar nominations, and ultimately won the Academy Award for Best Special Visual Effects. Assembled by Kubrick's assistant Ivor Powell, this black vinyl binder features 168 35mm slides showing various scenes of the film including the apes, moon, Monolith, astronauts, Stargate, and spaceships (some of which from shots not included in the final cut of the film), 12 5.75 cm x 5.75 cm (2.25" x 2.25") production slides showing characters, Pan Am hostesses, astronauts, and the Discovery EVA pod. This lot exhibits minor bending to the binder and grime to the slides. Dimensions: 25.5 cm x 29.25 cm x 4 cm (10" x 11.5" x 1.5")

**Estimate: £3,000 - 6,000**

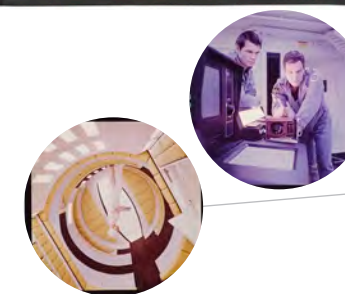

**826**  
Stella Oleson's (Melissa George) Fire Marshal Badge and Name Tag n  
**30 Days Of Night (2007)**

Stella Oleson's (Melissa George) fire marshal badge and name tag from David Slade's vampiric horror film 30 Days of Night. Fire Marshal Stella, the estranged wife of Sheriff Eben Oleson, wore her badge and name tag while on duty. The badges are both made of aluminium. Dimensions (fire marshal badge): 8 cm x 5.5 cm x 1 cm (3.25" x 2.25" x 0.5")

**Estimate: £800 - 1,600**



**827**  
Dillios (David Wenham) Partial Costume m  
**300 (2006)**

A partial Dillios (David Wenham) costume from Zack Snyder's 2006 historical action film 300. This lot consists of a brown leather codpiece, a brown leather eyepatch and a white bandage. Dillios wore his costume throughout the film as he fought the invading Persian forces of King Xerxes (Rodrigo Santoro), and bound his eye after losing it during battle. He wore his leather eyepatch a year later, while recounting the tale of the Battle of Thermopylae and the life of Leonidas I (Gerard Butler). The codpiece is marked "Dillios "C"" internally and features metal stud detailing along the belt. The bandage features intentional dirtying and staining from stage blood.

**Estimate: £1,000 - 2,000**



**828**  
Tom Welles' (Nicolas Cage) Projector with Pair of Reels m  
**8Mm (1999)**

Tom Welles' (Nicolas Cage) projector with a pair of reels from Joel Schumacher's 8mm. Welles used his portable recorder to rewatch the reel given to him while he investigated Mary Ann's (Jenny Powell) disappearance in Hollywood. This lot consists of one projector from Bolex, and two reels, one with film and one without. Made of metal with plastic components, the projector features turnable knobs and dials. This lot exhibits a buildup of grime in the crevices and discolouration. Dimensions: 28 cm x 17.75 cm x 28 cm (11" x 7" x 11") Contains electronic and mechanical components; see notice in the Buyer's Guide.

**Estimate: £1,500 - 3,000**



**829**  
Clapperboard m  
**About A Boy (2002)**

A clapperboard from the production of Chris Weitz and Paul Weitz's rom-com About a Boy. In the late 1990s and early 2000s, actor Hugh Grant was arguably the A-lister of A-listers, particularly in the rom-com genre. About a Boy was another huge commercial success added to Grant's portfolio of leading roles. This clapperboard features the film's title, "The Weitz Brothers", and the name of the film's director of photography, Remi Adefarasin. The remnants of faded black marker pen are found across the acrylic slate. A handwritten "2001" is still discernible beside the date section. The clapperboard's sticks are wood, secured to the acrylic slate by metal bolts. Dimensions: 4.0 x 28.3 x 24.7 (1.57 x 11.14 x 9.72)

**Estimate: £1,000 - 2,000**



**830**  
Martin Asbury Hand-drawn Production Storyboards m  
**Air America (1990)**

A collection of storyboards from the production of Alfonso Cuarón's dystopian action thriller film Children of Men, all hand-drawn by veteran storyboard artist Martin Asbury. Asbury has storyboarded many high-profile films such as Labyrinth, Interview with the Vampire and the final two instalments of the Harry Potter series. The lot comprises 76 pages depicting various scenes from the film. The storyboards are hand-drawn and coloured in mixed media on paper and card, and feature handwritten annotations. Dimensions: 30 cm x 21.5 cm x 2 cm (11.75" x 8.5" x 1")

**Estimate: £500 - 1,000**

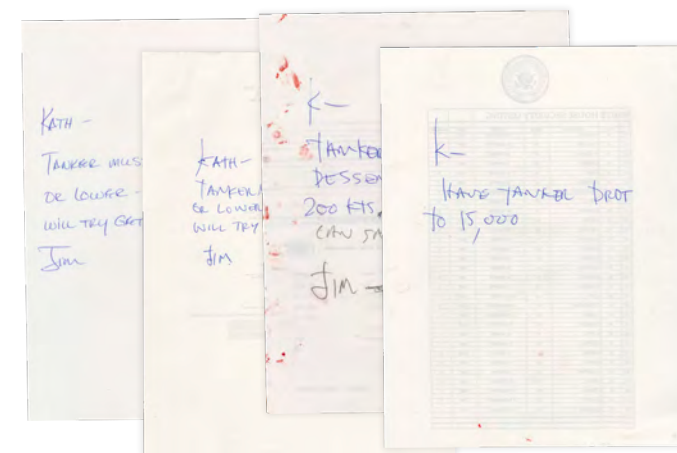

**831**  
President James Marshall's (Harrison Ford)  
White House Faxes m  
**Air Force One (1997)**

President James Marshall's (Harrison Ford) White House faxes from the production of Wolfgang Petersen's Air Force One. Marshall faxed VP Kathryn Bennett (Glenn Close) to get her to instruct the tanker to force Air Force low enough for Marshall to help the hostages escape by parachute. This set consists of one bundle of paperwork with the cover addressed to "K," inscribed with a note about the tanker being at 15,000 feet, and signed by "Jim" in Ford's own hand; a second bundle with a handwritten cover page addressed to "Kath" and signed "Jim" by a member of the prop team; a third bundle with a handwritten cover matching the second created per the direct request of director Petersen; and a printed version dated "SEP-23-97" and created by production for when the White House received Marshall's fax. The note handwritten by Ford is blood-stained by production, while the rest exhibit edge discoloration. Dimensions: (each) 21.75 cm x 28 cm (8.5" x 11")

**Estimate: £800 - 1,600**



**832A**  
King Philip II's (Val Kilmer) Crown m  
**Alexander (2004)**

King Philip II's (Val Kilmer) crown from Oliver Stone's Alexander. King Phillip wore his crown as the King of Macedon until his murder. This lot consists of a gold-colour metal sculpted leaf crown with a circular metal rod base. Gold-colour ribbons were added to the back after production. The crown exhibits minor tarnishing.

**Estimate: £2,500 - 5,000**



**832**  
Set of Three Hand-painted Animation Cels m  
**Akira (1988)**

A set of three hand-painted animation cels from the production of Katsuhiro Otomo's animated cyberpunk action film Akira. The cels are painted onto clear acetate sheets, and feature Tetsuo Shima, two police officers, and Keneda. The Tetsuo cel is painted onto an A3 sheet, and the cels of the officers and Keneda are both painted onto A4 sheets, and come layered with the original sketch on paper. Each of the sheets is numbered: Kened's cel is numbered "A4", the officers are numbered "1053 C4" and Tetsuo is numbered "1P43 C45". Dimensions: 54 cm x 34 cm (21.25" x 13.5")

**Estimate: £1,500 - 3,000**



**833**  
Pair of USCSS Nostromo Patches m  
**Alien (1979)**

A pair of USCSS Nostromo patches from Ridley Scott's sci-fi horror Alien. Members of the Nostromo crew wore patches on their clothing throughout the film. These patches, which display the Nostromo insignia, were made for the production as backups and show no sign of having been stitched to a garment. Dimensions (one patch): 10.5 cm x 7.75 cm x 0.5 cm (4.25" x 3" x 0.25")

**Estimate: £2,000 - 4,000**



**834**  
Ripley's (Sigourney Weaver) Name Badge, USSC Nostromo Crew Patches, Insignias and Transfers m  
**Alien (1979)**

A Ripley (Sigourney Weaver) name badge, Nostromo crew patches, insignias and transfers from Ridley Scott's horror sci-fi film Alien. Ripley and other crew members wore name badges and mission patches on their spacesuits, as well as insignias on their crew uniforms. The insignias are made of metal, as is the name badge. The lot is accompanied by a collection of postcards and behind-the-scenes still images. Dimensions: (transfer) 33.25 cm x 19.25 cm (13" x 7.5")

**Estimate: £1,000 - 2,000**

**835**  
USSC Nostromo Ladder Section m  
**Alien (1979)**

A Nostromo ladder section from Ridley Scott's sci-fi horror film Alien. Ladders allowed the crew of the Nostromo to move between the spaceship's different levels. This hollow fibreglass ladder piece comprises two steps, and the fibreglass has shimmering glitter cast into it. The lot is accompanied by a promotional photo of the cast standing in front of a ladder on set. The ladder has some wear from use and age, most notably paint transfer and cracking to the fibreglass. Dimensions: 61 cm x 63 cm x 6 cm (24" x 24.75" x 2.25")

**Estimate: £3,000 - 6,000**



**836**  
Collection of 66 Colour 35mm Slides n  
**Alien (1979)**

A collection of 66 colour 35mm slides from Ridley Scott's Alien. These film slides depicted various scenes throughout the film. This lot consists of 66 slides in white mounts with hand-marked numbers and letters. They come in five clear plastic sleeve projectors. This lot exhibits discolouration, frayed board fibre, and illegible text. Dimensions: (each) 5 cm x 5 cm (2" x 2")

**Estimate: £1,200 - 2,400**



**837**  
Annotated Script Page and Ridleygram m  
**Alien (1979)**

An annotated script page and Ridleygram from the production of Ridley Scott's sci-fi horror Alien. Ridleygrams are the nicknames for hurriedly drawn doodles and storyboards produced by Scott himself. The images are annotated and depict the scene in which the Nostromo is preparing to land on LV-426. It is hand-drawn on the back of a script page dated "June 30th, 1978". The annotated script page is dated "August 7th, 1978" and features handwritten annotations in black ink. Both pages are hole-punched and printed on pink paper. Dimensions (each page): 28 cm x 21.5 cm (11" x 8.5")

**Estimate: £1,000 - 2,000**

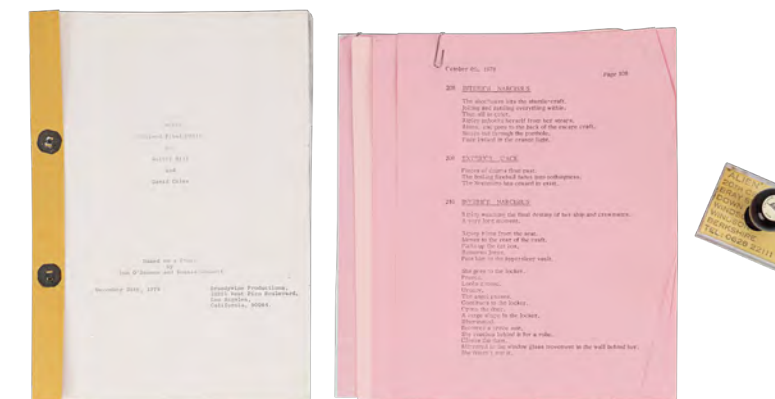
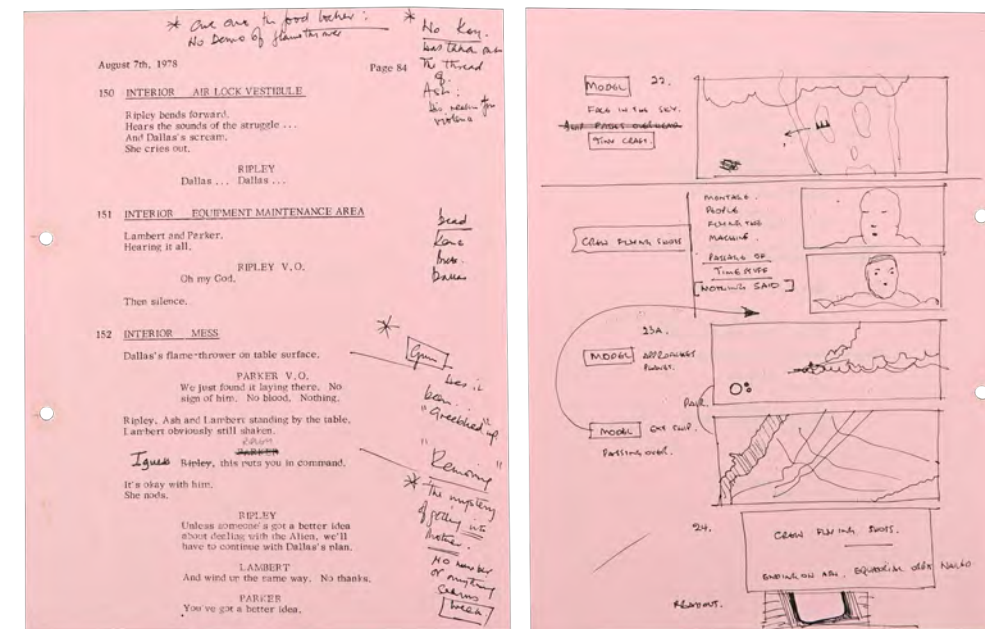

**838**  
Revised Final Draft Script, Script Revision Pages and Production Stamp tΔ  
**Alien (1979)**

A revised final draft script, script revision pages and stamp from the production of Ridley Scott's Alien. The lot comprises a revised final draft script dated "December 28th, 1978", credited to Walter Hill and David Giler and bound between yellow card covers; dozens of script revision pages held together in small sections with paperclips; and a rubber stamp with the film's title and the production's address at Bray Studios. The pieces have minor wear from production use and age, including some staining and creasing. Dimensions (script): 30 cm x 21 cm x 1 cm (11.75" x 8.25" x 0.5")

**Estimate: £1,000 - 2,000**

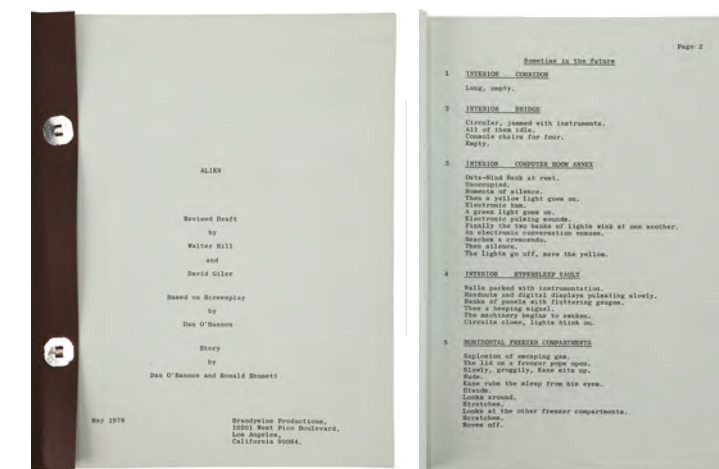

**839**  
Production Revised Script tΔ  
**Alien (1979)**

A production revised script from Ridley Scott's sci-fi horror Alien. This is a 114-page full-length revised draft dated "May 1978". The script is printed on paper and bound together within a brown textured cover folder. Dimensions: 28 cm x 22 cm x 1.5 cm (11" x 8.75" x 0.5")

**Estimate: £1,000 - 2,000**

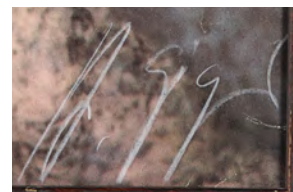

**840**  
H.R. Giger-autographed  
Alien Ship Print m  
Alien (1979)

A framed print of the derelict ship from Ridley Scott's Alien. The print has been autographed by Swiss artist and Alien designer H.R. Giger. The print depicts the derelict, wishbone-shaped craft on the moon of Acheron (LV-426). The ship underwent a number of design alterations, with most early concepts rejected by Scott on the basis that they were too "rational", when it was intended to be completely inhuman. Scott turned to Giger, who also designed the Alien itself. "Giger's first drawing was just a knockout," he later recalled. "I took one look at it and said, 'That's it.'" The print is mounted in a wooden frame. Dimensions: 109 cm x 80 cm x 3 cm (43" x 31.5" x 1.25") The autographs in this lot have been professionally authenticated by expert Garry King; see notice in the Buyer's Guide.

**843**  
H.R. Giger-autographed Model Xenomorph m  
Alien (1979)

A model xenomorph autographed by H.R. Giger during the promotion of Ridley Scott's Alien. This fan-made model was created before the film was widely released in the UK. It was presented to Giger - the Swiss artist responsible for designing the titular alien - at an autograph signing at Forbidden Planet in London on Wednesday 5 September 1979, the day before the film premiered at the Odeon Leicester Square. Giger's autograph adorns the left thigh alongside the date "5/9/79". The model is primarily made of resin, plastic and papier-mâché, and is hand-painted. It has some wear, most notably chips and cracks all over. Dimensions: 64 cm x 18 cm x 45 cm (25.25" x 7" x 17.75") The autograph in this lot has been professionally authenticated by expert Garry King; see notice in the Buyer's Guide.

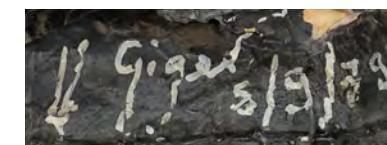

**Estimate: £2,000 - 4,000**

**841**  
H.R. Giger-autographed Poster o  
Alien (1979)

A poster autographed by H.R. Giger from the promotion of Ridley Scott's sci-fi masterpiece Alien. The original alien designer, Giger, won the Academy Award in 1980 in the Best Effects category for his work on Alien. He has signed his autograph in black marker pen at the bottom of the poster, which depicts the notorious cracking egg that makes this piece instantly recognisable. A still photograph of Giger signing the poster is included. Some of the poster's corners have broken off, while others exhibit crumpling. Dimensions: 103.25 cm x 68.75 cm (40.75" x 27") The autographs in this lot have been professionally authenticated by expert Garry King; see notice in the Buyer's Guide.



**Estimate: £1,000 - 2,000**

**Estimate: £800 - 1,600**

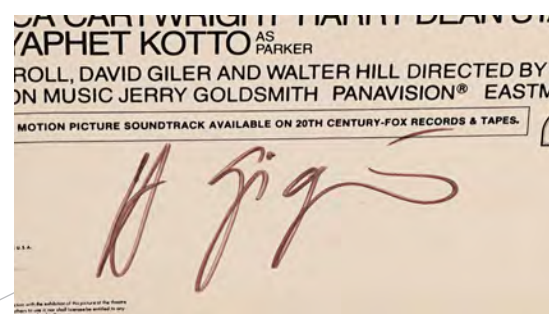

**844**  
Life-size Hollywood  
Collectibles Group  
Xenomorph Statue m  
Alien (1979)

A life-size recreation of the xenomorph from Ridley Scott's Alien. Designed by H.R. Giger, the xenomorph is one of the most iconic and fearsome monsters in cinematic history. This 1:1 scale model was a limited edition release by Hollywood Collectibles Group. It is predominantly made of fibreglass, and parts of the body were made with reference to the original production. It has been hand-painted and features ornate detailing, including a pale skull visible inside the translucent domed head. The statue has some paint wear in places and stands on a metal base. Dimensions: 83 cm x 60 cm x 223 cm (32.75" x 23.5" x 87.75")

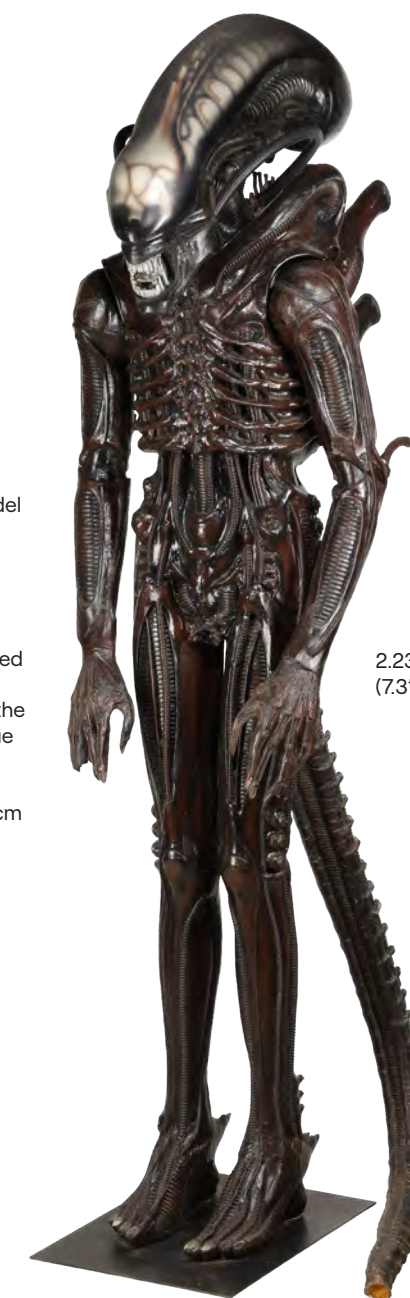

2.23 m (7.3')

**Estimate: £3,000 - 6,000**

**845**  
Pvt. Frost's  
(Ricco Ross)  
Screen-matched  
Colonial Marine  
Fatigues Costume o  
Aliens (1986)

Pvt. Frost's (Ricco Ross) screen-matched Colonial Marine fatigues from James Cameron's Aliens. Frost and his fellow Colonial Marines wore fatigues under their armour as they battled against Xenomorphs alongside Ellen Ripley (Sigourney Weaver). The layout of the camouflage patterns in the sleeves and pants screen-match this costume to when Frost first encounters the facehuggers encased in lab containers.



This costume consists of a cotton two-pocket button-up shirt with a USCM eagle patch on the right sleeve, as well as cargo trousers with a matching custom brown, tan, and grey camouflage pattern. The front of the shirt is hand-marked "Hicks" with discolouration over the top of it, and faded writing near the interior collar reads "Biehn." The trousers were subsequently altered to be reused for a smaller performer, as evidenced by the visible tailoring, and the shirt was similarly re-tailored, with the rolled-up sleeves having since been cut away and the patch attached glued on after production. This lot exhibits discolouration, pulled and frayed threads, and tears.

**Estimate: £3,000 - 6,000**

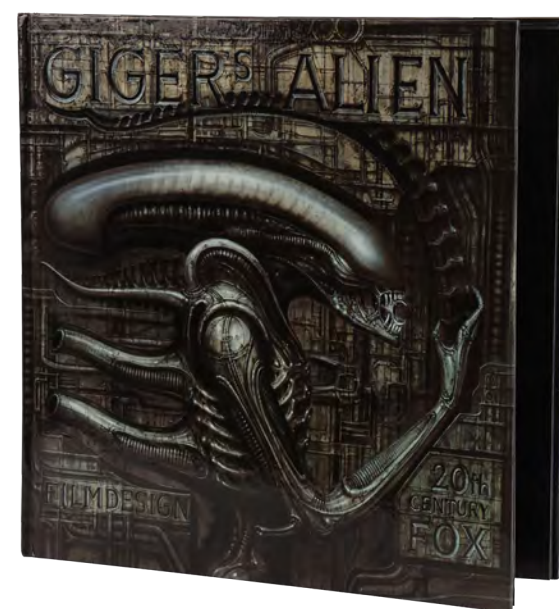

**842**  
H.R. Giger-autographed Book o  
Alien (1979)

A hardback copy of Giger's Alien autographed by the designer himself, H.R. Giger. The original alien designer, Giger, won the Academy Award in 1980 in the Best Effects category for his work on Alien. This book, printed in German, presents Giger's insight into the designs of the aliens and pictures of his original concept artwork. Giger has autographed the cover page of this book in white marker. A still photograph of Giger signing the book is included. Dimensions: 30.5 cm x 30.5 cm x 1.25 cm (12" x 12" x 0.5") The autographs in this lot have been professionally authenticated by expert Garry King; see notice in the Buyer's Guide.

**Estimate: £1,000 - 2,000**





**846**  
Xenomorph Warrior Hand †  
**Aliens (1986)**

A xenomorph warrior hand from James Cameron's Aliens. Xenomorph warriors attacked the Colonial Marines throughout the film, and this hand was made for the deleted scenes in which the xenomorphs tested the sentry guns by throwing their bodies in the line of fire. These scenes were restored for the Aliens Special Edition. The three-fingered hand is made of foam rubber and features piping and wiring in the arm section, which would have exploded with the creature's acid blood. The foam rubber has become dry and fragile, and there are several notable cracks and tears. Dimensions: 48 cm x 21 cm x 14 cm (19" x 8.25" x 5.5")

**Estimate: £3,000 - 6,000**



**847**  
Colonial Marine M40 Grenade †  
**Aliens (1986)**

A USCM M40 grenade from James Cameron's sci-fi action sequel Aliens. Marines, including Hicks (Michael Biehn), carried small M40 HEDP grenades in webbing on their armour during their mission on LV-426, while Vasquez (Jenette Goldstein) and Gorman (William Hope) memorably used one during their last stand. The grenade is constructed from a 12-gauge aluminium snap cap with some additional machine embellishments. Dimensions: 5.75 cm x 2.25 cm x 2.25 cm (2.25" x 1" x 1")

**Estimate: £500 - 1,000**



**848**  
Acheron Colony Child's Tricycle †  
**Aliens (1986)**

An Acheron Colony child's tricycle from James Cameron's sci-fi sequel Aliens. Children were playing with a tricycle in the halls of the main colony building in the Special Edition. The tricycle is plastic and painted orange. It was repainted after the production and has since been sympathetically restored. A Weyland-Yutani Corp plaque is adhered to the front. The wheels are black and the front wheel has black tape over the tread. The seat is no longer present. The tricycle has some paint wear and some minor cracking. The plaque was previously screwed to the front but is now stuck with tack. Dimensions: 98 cm x 52 cm x 53 cm (38.5" x 20.5" x 20.75")

**Estimate: £500 - 1,000**



**849**  
Three Production-made Colonial Marine Armour Collars †  
**Aliens (1986)**

Three production-made Colonial Marine armour collars from James Cameron's sci-fi action sequel Aliens. US Colonial Marines wore metal armour while fighting the xenomorphs on LV-426. From the collection of legendary armourer Terry English, these pieces were ultimately unused in the film at the request of the sound recordist, as they were too noisy on set. The pieces are made of aluminium and hand-painted with a camouflage design. The inside of the armour features foam padding. Dimensions (each): 7.5 cm x 20 cm x 7.5 cm (3" x 8" x 3")

**Estimate: £600 - 1,200**



**850**  
Set of "Smart Ass" Dropship Model Miniature Landing Gear Components †  
**Aliens (1986)**

"Smart Ass" dropship model miniature landing gear components from James Cameron's Aliens. Bishop (Lance Henriksen) remotely operated a second dropship known as "Smart Ass" to rescue the survivors of the Bug Stomper dropship's crash-landing on LV-426, but its landing gear malfunctioned, allowing the xenomorph Queen to board it. These 16 components were created for close-up inserts of Smart Ass' landing gear. It consists of panelling, joints, and structural elements made of resin, wood, and metal and primarily painted grey with one yellow component. Following production, the components underwent sympathetic restoration. They exhibit cracking, chipping, paint flaking, and small elements broken off throughout. Dimensions: (largest) 81.5 cm x 45.75 cm x 15.25 cm (32" x 18" x 6")

**Estimate: £3,000 - 6,000**



**851**  
Production-made Chestbuster Casting †  
**Aliens (1986)**

A chestbuster casting from the production of James Cameron's sci-fi action sequel Aliens. A chestbuster shocked the Colonial Marines as it burst from the chest of a cocooned colonist (Barbara Coles) under the atmosphere processing station. This plaster casting originated from the production's model shop. It is hollow, painted black and is missing the creature's little arms. There is some wear to the paint, most notably around the base and the tip of its head. Dimensions: 23 cm x 11 cm x 35 cm (9" x 4.25" x 13.75")

**Estimate: £2,000 - 4,000**



**852**  
Pair of Sulaco Floor Tiles and  
Hadley's Hope Wall Panel m  
**Aliens (1986)**

A pair of Sulaco floor tiles and a Hadley's Hope wall panel from James Cameron's Aliens. The floor tiles are from the spaceship which transported Ripley (Sigourney Weaver) and the Colonial Marines to the planet LV-426. One of the tiles is full-size, and one is a smaller scale for the miniature sets; both are painted silver. Red wall panels were seen around the colony of Hadley's Hope. It is made of vacuum-formed plastic and has tape on the reverse to adhere it to the set walls. It also has additional tape added to repair some sections, but still shows some cracks around the edges. Dimensions (wall panel): 122.5 cm x 85 cm x 3.5 cm (48.25" x 33.5" x 3.25")

**Estimate: £1,000 - 2,000**



39 cm  
(15.25")

**853**  
USS Sulaco Launch Bay Model  
Miniature Set Piece m  
**Aliens (1986)**

A USS Sulaco launch bay model miniature piece from James Cameron's sci-fi action sequel Aliens. The USS Sulaco carried two dropships - "Bug Stomper" and "Smart Ass" - which were held in place by large metal arms. This piece is predominantly made of resin and painted to look like metal. It features metal piping down the sides and the arm hinges in the middle. The piece has paintwear and some staining, and the piping down each side is loose. Dimensions (folded up): 39 cm x 5 cm x 14 cm (15.25" x 2" x 5.5")

**Estimate: £600 - 1,200**



**854**  
Xenomorph Queen Tail Tip m  
**Aliens (1986)**

A xenomorph Queen tail tip from James Cameron's sci-fi sequel Aliens. While attempting to contact a terraforming colony, Ripley (Sigourney Weaver) and her comrades battled against the Alien Queen and her offspring. At the film's climax, the Queen skewered Bishop (Lance Henriksen) with her sharp tail. This foam rubber tail is formed as a sequence of vertebrae flowing from large to small. The tail exhibits a slight tear at the tip end, which has been repaired. Dimensions: 122 cm x 25 cm x 16 cm (48" x 9.75" x 6.25")

**Estimate: £1,000 - 2,000**

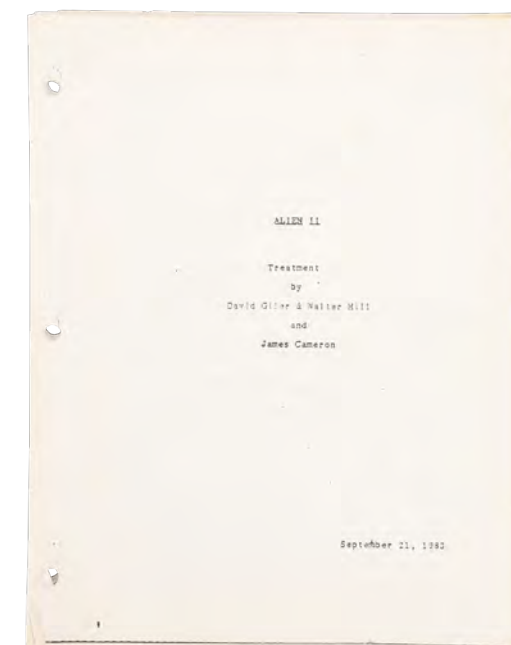
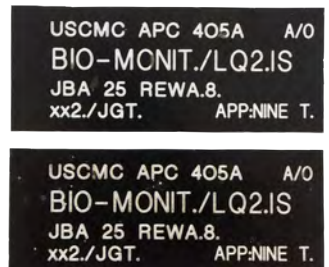

**855**  
Script Treatment and APC  
Bio-Monitor Plaques +Δ  
**Aliens (1986)**

A script treatment and pair of APC bio-monitor plaques from James Cameron's sci-fi action sequel Aliens. The script treatment - credited to David Giler, Walter Hill and James Cameron and dated "September 21, 1983" - comprises 47 loose pages with an early outline of the story for the film. Plaques are fixed above the bio-monitors aboard the APC, which Lt. Gorman (William Hope) used to track the health of the Colonial Marines. The plaques are black plastic with debossed lettering. The script pages have minor staining, tears and edgewear, and the plaques have some staining. Dimensions (each plaque): 4 cm x 10 cm (1.5" x 4")

**Estimate: £700 - 1,400**



**856**  
Sigourney Weaver, Bill Paxton,  
Michael Biehn and Main Cast  
Autographed One Sheet o  
**Aliens (1986)**

A commercial poster featuring the "Ripley Style" US One Sheet design for James Cameron's Aliens. This style of poster was initially recalled from theatres by the studio because it was felt that the alien eggs might spoil the climax of the film. This poster features an array of autographs - all in black ink - from twelve cast members, including Sigourney Weaver (Ripley), Carrie Henn (Newt), Michael Biehn (Corporal Dwayne Hicks), and Bill Paxton (Private Hudson). The poster is in near-mint condition and rolled for storage. It is accompanied by Celebrity Authenticity COA cards for all signatures. Dimensions: 67 cm x 98 cm (26.5" x 38.5") The autographs in this lot have been professionally authenticated by expert Garry King; see notice in the Buyer's Guide.

**Estimate: £1,000 - 2,000**

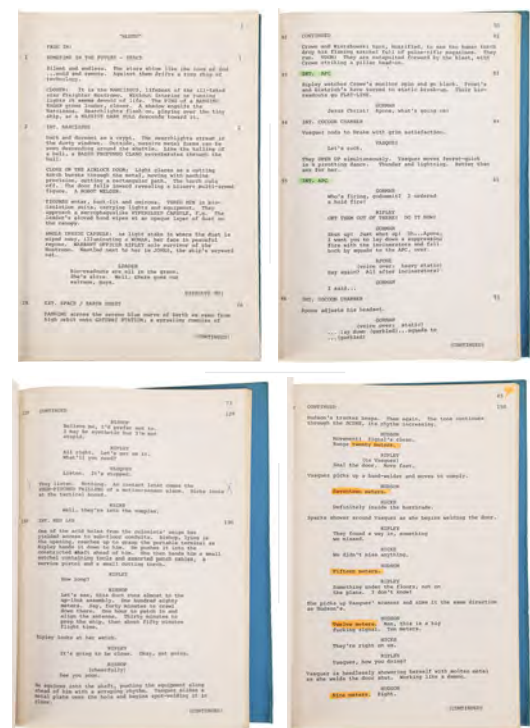

**857**  
Highlighted Final Draft Script m  
**Aliens (1986)**

A highlighted final draft script from the production of James Cameron's sci-fi action sequel Aliens. This final draft script is credited to James Cameron, dated "September 1985", and has "132" handwritten on the title page. Bound between blue card covers with metal fastenings, it is 106 pages long and page 85 has some of Hudson's (Bill Paxton) lines highlighted in orange and "Int. APC" is highlighted in green on several pages. There is some minor staining on the cover. Dimensions: 28 cm x 23 cm x 1.5 cm (11" x 9" x 0.5")

**Estimate: £800 - 1,600**



**858**  
**Sigourney Weaver Autographed Poster m**  
**Aliens (1986)**

A Sigourney Weaver autographed poster for James Cameron's sci-fi sequel Aliens. Weaver has autographed the poster in black marker pen. It depicts her character, Ripley, protecting Newt (Carrie Henn) whilst stood amongst the Alien Queen's eggs. The poster features a Celebrity Authentics hologram and is also accompanied by a certificate of authenticity card with a picture of Weaver autographing the poster. Dimensions: 61 cm x 40.75 cm (24" x 16") The autographs in this lot have been professionally authenticated by expert Garry King; see notice in the Buyer's Guide.

**Estimate: £500 - 1,000**

**859**  
**Cast-Autographed NERF M41A**  
**Pulse Rifle m**  
**Aliens (1986)**

A cast-autographed NERF M41a pulse rifle from James Cameron's Aliens.

The NERF gun is based on an M41A pulse rifle, the weapon used aboard the Sulaco spaceship. It has been autographed in white ink by 10 members of the cast, including Lance Henriksen (Bishop), and Michael Biehn (Hicks). Each of the cast members have written their character's name besides their signature, and Biehn has also included a quote from the film; "Remember, short controlled bursts." The gun comes in its original box (also autographed by Henriksen). It comes with 10 regular darts, and three mega darts. It is battery powered, and features a functional LCD round counter that counts down from 95. It also produces sounds inspired by the film. Dimensions (box): 76.5 cm x 30 cm x 6.5 cm (30" x 11.75" x 2.5")

The autographs in this lot have been professionally authenticated by expert Garry King; see notice in the Buyer's Guide.

**Estimate: £800 - 1,600**

**860**  
**Xenomorph Tail Tip m**  
**Alien3 (1992)**

A Xenomorph tail tip from David Fincher's sci-fi horror film Alien3. The xenomorph, sometimes called the 'dog alien' or 'runner' in this particular iteration, terrorised the maximum-security correctional facility Fiorina "Fury" 161, and in an attempt to restrain it Ellen Ripley (Sigourney Weaver) grabbed the alien by its bladed tail tip. It is made of foam latex, painted dark brown. The tail tip has dried out over time, which has led to it cracking and chipping in places, but otherwise it remains in good condition. Dimensions: 56 cm x 12 cm x 10 cm (22" x 4.75" x 4")

**Estimate: £500 - 1,000**



**861**  
**Production-made Full-size**  
**Xenomorph Head Casting m**  
**Alien3 (1992)**

A production-made full-size Xenomorph head casting from David Fincher's sci-fi horror sequel Alien3. After emerging from a gestation period inside the stomach of a dog, a sleeker, smaller, and dipedinal form of xenomorph, sometimes called the "dog alien", attacked the inhabitants of a penal colony on the planet Fiorina 161. This head was production made, and made using original moulds, but ultimately unused. It is made of resin and fibreglass, painted black, and the jaw is intentionally separate to the rest of the head. Dimensions: 80 cm x 23 cm x 21 cm (31.5" x 9" x 8.25")

**Estimate: £3,000 - 6,000**



26 cm (10.25")



80 cm (31.5")

**862**  
**Production-made Xenomorph Puppet Head m**  
**Alien3 (1992)**

A production-made rod-puppet xenomorph head from David Fincher's sci-fi horror sequel Alien3. After gestating in the stomach of a dog, a sleeker, smaller, and quadrupedal form of xenomorph attacked the inhabitants of a penal colony on the planet Fiorina 161. Black resin puppets were constructed for filming sequences where the xenomorph's movements were aggressive. The puppet is displayed on a wooden stand with a metal rod for support. Dimensions: 26 cm x 10.25 cm x 21.5 cm (10.25" x 4" x 8.50")

**Estimate: £2,000 - 4,000**

**863**  
**Martin Asbury Hand-drawn**  
**"Molten Lead to Final Sequence"**  
**Storyboard Pages m**  
**Alien3 (1992)**

A collection of Martin Asbury hand-drawn "Molten Lead to Final Sequence" storyboard pages from David Fincher's sci-fi horror sequel Alien 3. These four pages feature four illustrations each, rendered in pencil and ink. They depict part of the sequence where Ripley (Sigourney Weaver) and the prisoners lured the Xenomorph into a molten lead trap. Handwritten annotations accompany each drawing down the right side. Dimensions: 30 cm x 21.25 cm (11.75" x 8.25") Sold without copyright; see copyright notice in the Buyer's Guide.

**Estimate: £1,000 - 2,000**

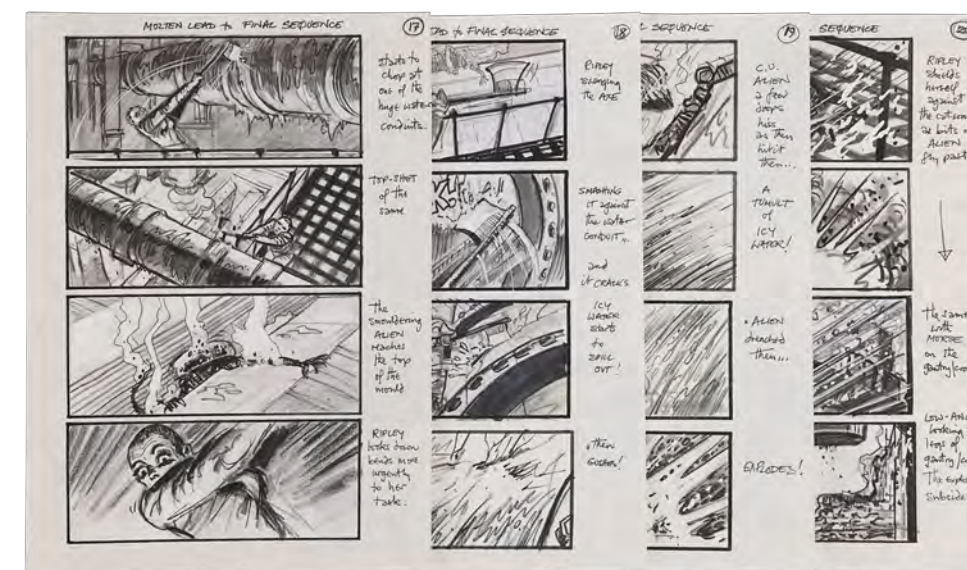



**864**  
 Martin Asbury Hand-drawn "Library" Storyboard Pages m  
**Alien3 (1992)**

A collection of Martin Asbury hand-drawn "Library" storyboard pages from David Fincher's sci-fi horror sequel Alien 3. These pages feature four illustrations each, rendered in pencil and ink. They depict Ripley (Sigourney Weaver) and the prisoners under attack from the Xenomorph while in the library. The page labelled "20" is missing its top frame, while the page labelled "19" is missing its third frame down. Dimensions: 30 cm x 21.25 cm (11.75" x 8.25") Sold without copyright; see copyright notice in the Buyer's Guide.

**Estimate: £1,000 - 2,000**

**865**  
 Script, Call Sheet, Storyboards, Production Paperwork, Premiere Tickets and Brochure m  
**Alien3 (1992)**

A script, call sheet, storyboards, production paperwork, premiere tickets, and a brochure from the production of David Fincher's sci-fi horror film Alien3. The script is credited to Walter Hill and David Giler, and is incomplete at 47 pages long. It is dated "January 11, 1991", bound in pink card and stamped "AN0038". The storyboards are of the film's opening sequence, in which Clemens finds Ripley, and Scene 57, Clemens' death. The paperwork includes costing sheets, call sheets, meeting notes, and schedules. Dimensions: 36 cm x 24 cm x 3 cm (14.25" x 9.5" x 1.25")

**Estimate: £500 - 1,000**

**866**  
 Vriess' (Dominique Pinon)  
 Grenade Launcher m  
**Alien Resurrection (1997)**

Vriess' (Dominique Pinon) grenade launcher from Jean-Pierre Jeunet's sci-fi horror sequel Alien: Resurrection. Vriess had several custom-made weapons attached to his wheelchair, and Christie (Gary Dourdan) used the launcher when the survivors of the xenomorph outbreak found themselves surrounded by xenomorph eggs. The launcher is predominantly made of metal and is intentionally distressed to look rusted and homemade. It has a shoulder strap attached to the top, a detachable grip and trigger, a moveable forestock, and an extendable buttstock. The weapon has some paint wear and signs of repair. Dimensions (extended): 75 cm x 8 cm x 20 cm (29.5" x 3.25" x 7.75")

**Estimate: £2,000 - 4,000**



no lot 867



**868**  
 Pair of Scar's (Ian Whyte) Extended Wrist Blades o  
**AVP: Alien Vs. Predator (2004)**

A pair of Scar's (Ian Whyte) extended wrist blades from Paul W.S. Anderson's AVP: Alien vs. Predator. Scar used extended wrist blades while on the hunt for xenomorphs. This lot consists of two jagged blades made of resin with wood supports airbrushed black and silver-colour. They feature production-drilled holes with one blade containing metal washers and nuts. Both are hand-marked "In Long" in black ink at the handle. Production intentionally distressed these weapons to appear used. This lot exhibits chipped paint, discolouration, and chipped resin. Dimensions: 81.25 cm x 10.25 cm x 10.25 cm (32" x 4" x 4")

**Estimate: £1,000 - 2,000**

**869**  
 Predator Combistick m  
**AVP: Alien Vs. Predator (2004)**

A Predator combistick from Paul W.S. Anderson's sci-fi crossover film AVP: Alien vs. Predator. The movie's three main Predators wielded their combisticks as they hunted xenomorphs. This full-size double-pronged combistick weapon was designed by Academy Award-winning special effects group Amalgamated Dynamics, Inc. (ADI). It is made of dense resin moulded around a steel pipe, hand-painted silver, copper, gold and grey. Its handle and two ornate wings are engraved with otherworldly markings that hark back to the combistick designs first seen in Stephen Hopkins' Predator 2. Dimensions: 213 cm x 9 cm x 6.5 cm (83.75" x 3.5" x 2.5")

**Estimate: £4,000 - 8,000**



213 m (7')



**870**  
David's (Michael Fassbender)  
Cave Drawings m  
**Alien: Covenant (2017)**

David's (Michael Fassbender) cave drawings from Ridley Scott's sci-fi horror sequel Alien: Covenant. Charcoal drawings decorated the walls of the cavernous temple David lived in, drawn by him during his tenure on the planet since the Prometheus mission failure. Included in this lot are six printed drawings of various sizes and subjects – two feature Prometheus protagonist Elizabeth Shaw (Noomi Rapace). The others feature various animal and alien studies. One drawing of an alien body part features printed annotations. The paper the drawings are printed on has been deliberately aged for production purposes, and has been rolled for storage. Dimensions: 77 cm x 10 cm x 10 cm (30.5" x 4" x 4")

**Estimate: £1,500 - 3,000**



**871**  
Paul Baumer's (Felix Kammerer)  
Distressed Uniform †Δ  
**All Quiet On The Western Front (2022)**

Paul Baumer's (Felix Kammerer) distressed uniform from Edward Berger's All Quiet on the Western Front. Baumer wore his German soldier uniform throughout the film, and it became increasingly worn and weathered during his travails. Berger's film was nominated for nine Academy Awards, and won four, including Best International Feature Film. The costume comprises a green woollen military jacket (labelled "1. Paul K5/1BB") and a pair of matching woollen trousers. The clothing has been intentionally distressed with dirt, tears, holes and faux frost. The lot is accompanied by several production tags and a continuity report featuring pictures of Baumer in costume.

**Estimate: £3,000 - 6,000**



**872**  
Tjaden Stackfleet's  
(Edin Hasanovic) Dirtied Uniform †Δ  
**All Quiet On The Western Front (2022)**

Tjaden Stackfleet's (Edin Hasanovic) uniform from Edward Berger's All Quiet on the Western Front. Stackfleet wore his German soldier uniform throughout the film, as it became increasingly worn and weathered. The lot comprises two woollen jackets (the first labelled "Hasanovic K4/4C", the second labelled "Hasanovic K4 7BB"); a pair of woollen military trousers (labelled "Hasanovic Edin of 90"); a steel helmet; a pair of leather boots (both labelled "#5"); and a metal gas-mask canister (labelled "#3 Muller #7 L. Behm") with a shoulder strap. The clothing has been intentionally distressed with dirt, tears, holes and faux frost. The lot is accompanied by several production tags and a continuity report featuring pictures of Hasanovic in costume.

**Estimate: £2,000 - 4,000**

**873**  
Stanislaus "Kat"  
Katzinsky's  
(Albrecht Schuch)  
Distressed Uniform †Δ  
**All Quiet On The Western Front (2022)**

Stanislaus "Kat" Katzinsky's (Albrecht Schuch) distressed uniform from Edward Berger's World War I drama All Quiet on the Western Front. Berger's film was nominated for nine Academy Awards®, winning four. The costume consists of one woollen jacket (labelled "K5/1A#2"); a second woollen jacket (labelled "#2/K5/1B"); a pair of cotton corduroy trousers (labelled "#2K5/7A"); two woollen leg wraps; and a woollen cap. All the items have been intentionally distressed with dried mud. The second jacket features faux ice. A continuity report accompanies the costume.

**Estimate:  
£1,500 - 3,000**



**875**  
Stifler's (Seann William  
Scott) Wedding Suit m  
**American Wedding (2003)**

Stifler's (Seann William Scott) wedding suit from Jesse Dylan's American Wedding. Stifler wore his suit as a groomsman and holder of the ring when attending Jim's (Jason Biggs) and Michelle's (Alyson Hannigan) wedding. The suit's matching jacket and trousers are both by Emporio Armani, with "Stifler" handwritten in blue ink on a label inside the former. Both the jacket (size "40") and the trousers (size "38") are made of wool. The rest of the suit comprises a white cotton shirt (size "15 1/2 - 33") by John W. Nordstrom with "Stifler" handwritten in blue ink on its label; a patterned pocket square; a striped tie; a leather belt; and a pair of black leather Pronto Uomo shoes (size "9 1/2").

**Estimate:  
£3,000 - 6,000**



**874**  
John Kennex's  
(Karl Urban) Gun  
and Police Badge m  
**Almost Human (T.V.  
Series, 2013-2014)**

John Kennex's (Karl Urban) gun and police badge from the sci-fi crime drama series Almost Human. Kennex, a cop who lost his partner in a catastrophic attack, used his sidearm throughout the series as he adjusted to working with his new partner, a discontinued android named Dorian (Michael Ealy). The gun is based on a Taurus PT92AF, which has been fitted into a futuristic shell. It is hard rubber and painted mostly black with brown grips, which are hand-painted to imitate wood. It features a serial number and has a flexible trigger. Accompanying the pistol is an octagonal brass police badge engraved with a Delta Division emblem. It comes in a black leather case with magnetic closures, and Kennex's photo ID, which details his officer information. The gun exhibits some paint wear. Dimensions (gun): 22 cm x 15.5 cm x 5 cm (8.75" x 6" x 2")  
Restricted ownership; see replica firearm notice in the Buyer's Guide.

**Estimate:  
£1,000 - 2,000**



**875A**  
George Lutz's  
(Ryan Reynolds)  
Stunt Axe Ω  
**The Amityville Horror (2005)**

George Lutz's (Ryan Reynolds) stunt axe from Andrew Douglas' The Amityville Horror. George used his axe to cut firewood and to terrorise his family as he slowly succumbed to the voices, until he used it to kill Harry the dog. Later, in a possessed state, George imagined striking Kathy (Melissa George) in the stomach with it. This lot consists of one foam axe with a rod on the interior for support and stability. The head was painted in a metallic silver-colour and the handle was painted in various shades of brown to give it a realistic wood appearance. Production purposefully distressed this axe to give it a grimy appearance. This lot exhibits some discolouration at the bottom of the handle and flaked paint. Dimensions: 89.25 cm x 21 cm x 4 cm (35.25" x 8.25" x 1.5")

**Estimate:  
£2,000 - 4,000**





**876**  
 Undead Jack's (Griffin Dunne) Prosthetic Hand m  
**An American Werewolf In London (1981)**

An undead Jack's (Griffin Dunne) prosthetic hand from John Landis' *An American Werewolf in London*. Jack was killed by a werewolf before returning undead with his body decaying. This latex hand was used in the scene towards the film's end where David (David Naughton) met undead Jack in an adult cinema in Piccadilly Circus. Dunne was required to assist with operating his character's puppet so that his dialogue could be synced with David's. This meant Dunne could not gesture, so the hand was applied to special effects assistant Joseph Ross instead. Ross then performed the gesture with the hand whilst keeping the rest of his body out of shot. The hand itself was designed by prosthetics supremo Rick Baker, who won the first-ever Academy Award in the Best Make-up category for his work on the film. The item comes with a detailed letter from Ross. Dimensions: 28.5 cm x 17 cm (11.25" x 6.75")

**Estimate: £2,000 - 4,000**

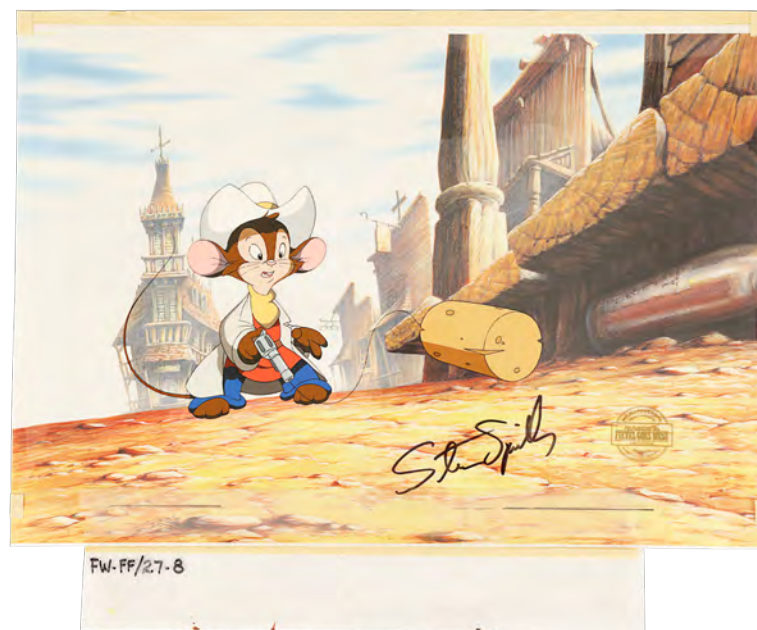

**877**  
 Steven Spielberg-Autographed Original Hand-painted  
 Fievel Animation Cel m  
**An American Tail: Fievel Goes West (1991)**

A Steven Spielberg-autographed original hand-painted Fievel cel from Phil Nibelink and Simon Wells' *An American Tail: Fievel Goes West*. The cel is autographed by producer Spielberg, and bears the official Amblin Entertainment seal of authenticity. The cel is from the fantasy gunfight sequence, in which one of Fievel's bullets turns into the cork from his toy gun. The lot is accompanied by a laser copy of an original production background and an Amblin Entertainment certificate of authenticity. Dimensions: 40.25 cm x 33.5 cm (15.75" x 13.25") Sold without copyright; see copyright notice in the Buyer's Guide. The autographs in this lot have been professionally authenticated by expert Garry King; see notice in the Buyer's Guide.

**Estimate: £1,000 - 2,000**



**878**  
 Original British Quad Poster Final Artwork by  
 Brian Bysouth Ω  
**An American Tail: Fievel Goes West (1991)**

Original final artwork by Brian Bysouth for the British Quad for Phil Nibelink and Simon Wells' animated sequel *An American Tail: Fievel Goes West*. This artwork is painted in gouache on board by renowned poster artist Bysouth, who also worked on posters for *Raiders of the Lost Ark*, *For Your Eyes Only* and *Highlander*, among others. The artwork is signed in the bottom right corner by Bysouth, with the artist also hiding his name on one of the floorboards. Dimensions: 81 cm x 102 cm (32" x 40.25") Sold without copyright; see copyright notice in the Buyer's Guide.

**Estimate: £3,000 - 6,000**

**879**  
 Life-size SFX Albin Alligator Head m  
**Annihilation (2018)**

A life-size SFX albino alligator head from Alex Garland's *Annihilation*. Lena (Natalie Portman) and her team were attacked by a mutated albino alligator while investigating "The Shimmer", a mysterious anomalous area with strange goings-on and mutated animals. The team then examined the animal, finding extra rows of teeth. The hollow fibreglass head has removable panels on the top of the head and the underside of the bottom jaw, which reveal wiring and the former placement sites of various squibs from when Lena shoots the animal to death. Each squib placement site is numbered and the head itself is labelled "1" inside. The head has some paint wear and a build-up of grime on the inside. Dimensions: 140 cm x 65 cm x 60 cm (55" x 25.5" x 23.5") Special shipping required; see special shipping notice in the Buyer's Guide.

**Estimate: £2,000 - 4,000**



**880**  
 Holcane Warrior Weapons and Mayan Sacrificial Tools m  
**Apocalypto (2006)**

Holcane warrior weapons and Mayan sacrificial tools from Mel Gibson's *Apocalypto*. Weapons like these were used by the Mayan raiders whilst attacking Jaguar Paw's (Rudy Youngblood) village, to sacrifice the captured villagers, and then again whilst hunting Jaguar Paw through the forest when he escaped. Included in this lot is a chakram, two macuahuits, two parts of a spear-type weapon, and a sacrificial knife and bowl. The weapons are made of wood and resin, and blades painted glossy black to resemble obsidian. Some of the weapons feature intricate carved designs, and the sacrificial knife and bowl are crafted to resemble bone, and are stained by stage blood. Dimensions: 82 cm x 30 cm x 10 cm (32.25" x 12" x 4") Edged, bladed or blunt object; see notice on Blades in the Buyer's Guide.

**Estimate: £1,000 - 2,000**



**881**  
 Gene Kranz's (Ed Harris) NASA ID Badge tΔ  
**Apollo 13 (1995)**

Gene Kranz's (Ed Harris) NASA ID badge from Ron Howard's drama *Apollo 13*. Chief Flight Director Kranz wore his NASA ID badge while in Mission Control as he tried to get the crew of *Apollo 13* back down to Earth safely. The ID is laminated paper with Kranz's name and a black-and-white headshot. It is attached to a metal clip. Dimensions: 10 cm x 7.75 cm x 1 cm (4" x 3" x 0.5")

**Estimate: £800 - 1,600**





**882**  
 Prince Hasan (Oliver Tobias)  
 Wedding Carpet Rider and  
 Khasim (Milo O'Shea) Carpet Rider  
 Miniatures M  
**Arabian Adventure (1979)**

A Prince Hasan (Oliver Tobias) wedding carpet rider miniature and a Khasim (Milo O'Shea) carpet rider miniature from Kevin Connor's Arabian Adventure. Prince Hasan and Princess Zuleira (Emma Samms) left their wedding on a magic flying carpet, and earlier in the film, Hasan and Khasim set off on a quest on another flying carpet. The wedding carpet is attached to a wooden base with a foam overlay and has a label with "Carpet Y" handwritten on it in blue ink. The canopy attached to this carpet is made of metal, finished to look like fabric. The remnants of electrical mechanisms remain on the top of both carpets. The lot also includes a Hasan ally miniature and a Caliph Alquazar (Christopher Lee) soldier miniature. All the miniatures have plastic bodies and rubber heads and are embellished with paint, faux hair, and resin boots. One of the metal poles that attaches the canopy to the carpet has detached from its binding. Dimensions (wedding carpet miniature): 44.5 cm x 19.5 cm x 18 cm (17.5" x 7.75" x 7") Contains electronics; see electronics notice in the Buyer's Guide.

**Estimate: £2,000 - 4,000**



**883**  
 Mr. Humphries' (John Inman) Pinstripe Suit +  
**Are You Being Served? (1977)**

Mr. Humphries' (John Inman) pinstripe suit from Bob Kellett's comedy Are You Being Served? Mr Humphries wore his pinstripe suit while working on the men's counter at Grace Brothers department store. This three-piece pinstripe suit comprises a jacket, trousers and a waistcoat, all navy blue with white pinstripes. The items are made of cotton, with nylon inner linings for the jacket and waistcoat. "13579 - 13.6.79 - J. Inman" is handwritten on two costume labels in blue ink; one in the jacket's right-sided inside pocket, the second inside the trousers. "1979 GSU 903 3Pc 25/30" has been handwritten in blue on a third label sewn into the inside of the trouser waistband.

**Estimate: £1,000 - 2,000**



**884**  
 Nuclear Code and Security Case M  
**Armageddon (1998)**

A nuclear code and security case from Michael Bay's sci-fi disaster film Armageddon. After he was ordered to remotely detonate the nuke by the President, General Kimsey (Keith David) broke open the tamper-proof security case to retrieve the code. Printed on red cardstock, this production-made remote detonation code features "DBDEGGTZ" in black ink, and comes encased in its security container, which is made of clear acrylic. This code was folded into thirds and displays two prominent production-made creases where the folds were made. This lot exhibits some fading of the letters across the creases, and gaps in the letters from printing. Dimensions: 16.5 cm x 9 cm (6.5" x 3.5")

**Estimate: £500 - 1,000**

**885**  
 Space Suit Helmet Parts M  
**Armageddon (1998)**

A space suit helmet parts from Michael Bay's sci-fi disaster film Armageddon. The astronauts wore their spacesuits to pilot the space shuttles Freedom and Independence, selected to fly to an asteroid on course for Earth, with the intent to destroy it in space. Included amongst the parts are pieces of a helmet and spacesuit, a resin collar and padded collar, and electric fans, still with wiring attached. Some of the parts are marked "USA" or "USAF", and the parts are made of various metals, resin, plastic and foam. Also included are a pair of trousers belonging to Colonel Willie Sharp (William Fichtner), to be worn under a spacesuit, with considerable padding around the calves and "Sharp" handwritten onto a label in the waistband. A production-used helmet storage case accompanies the parts. Some of the items have a slight odour from their time in storage, and the pieces do not combine into a full suit. Dimensions (case): 43 cm x 40 cm x 40 cm (17" x 15.75" x 15.75")



**Estimate: £500 - 1,000**

**886**  
 Passepartout's (Jackie Chan) Goggles M  
**Around The World In 80 Days (2004)**

Passepartout's (Jackie Chan) goggles from Frank Coraci's action adventure comedy film Around the World in 80 Days. Passepartout wore his goggles when assisting Phileas Fogg (Steve Coogan) in testing his latest invention, which broke the 50-mile-per-hour speed barrier. The goggles consist of metal and resin frames attached to a leather adjustable strap worn around the back of the head. The frames are leather-lined and foam-padded for comfort. A second pair of frames is attached by a hinge mechanism that can be stacked over the first. The frames no longer hold lenses and the item exhibits some wear.



**Estimate: £800 - 1,600**

**887**  
 Lost Necronomicon Pages  
 with Leather Cover M  
**Ash Vs Evil Dead - Judgement Day (2018), Tales from the Rift (2018)**

A collection of lost Necronomicon pages with a leather cover from Ash vs Evil Dead. In Season 3, Episode 9, "Judgement Day," the Dark Ones took the lost Necronomicon pages from Pablo (Ray Santiago) which he kept bound in leather. This lot consists of a raw leather cover with three printed Necronomicon pages. Production purposefully distressed the pages to give them an aged and bloodied appearance. This lot exhibits discolouration on the leather, notable fold lines, and paper edge fragility. Dimensions: 24.75 cm x 13 cm x 1.75 cm (9.75" x 5.25" x 0.75")



**Estimate: £3,000 - 6,000**



**888**  
 Gary's (Will Wallace) Screen-matched Lost Necronomicon Page with Additional Pages  $\Omega$   
**Ash Vs Evil Dead - Unfinished Business (2018)**

Gary's (Will Wallace) screen-matched lost Necronomicon page with additional pages from Ash vs Evil Dead. In Season 3, Episode 4, "Unfinished Business," Gary brought Necronomicon pages to Brock's hardware store in a flashback sequence. One page screen-matches due to notable tears and white painted areas on the page to when Gary put it down on the counter as he searched for Ash. This lot consists of three printed pages of paper front and back. Production purposefully distressed the pages to give them an aged and bloodied appearance. This lot exhibits fold lines, creases, and paper edge fragility. Dimensions: 21 cm x 28 cm (8.25" x 11")

**Estimate: £2,000 - 4,000**

**889**  
 Ash's (Bruce Campbell) Screen-matched Wooden Hand with Arm Prosthesis  $\Omega$   
**Ash Vs Evil Dead - El Jefe (2015), Books from Beyond (2015)**

Ash's (Bruce Campbell) screen-matched wooden hand with arm prosthesis from Ash vs Evil Dead. Ash used his wooden hand in the early part of the season, swapping it with his chainsaw weapon, until he lost the hand in the third episode of Season 1, "Books from Beyond." The nicks and wood grain screen-match to close-up shots from the Season 1 episode "El Jefe" as Ash headed out to the local bar. Additional scenes screen-match as well including when Amanda (Jill Marie Jones) attempted to arrest Ash in "Books from Beyond." This lot consists of a two-piece resin arm prosthesis with webbed elastane strap around the open end, and a wooden hand. The base of the hand and end of the prosthesis are fitted with interlocking wood parts. The prosthesis was painted in shades of red and brown giving it a realistic wood appearance. This lot exhibits notable adhesive around the strap, a buildup of grime, and pitting in the prosthesis. Dimensions: 23 cm x 20.5 cm x 7.75 cm (9" x 8" x 3")



**Estimate: £2,000 - 4,000**



**890**  
 Apple of Eden With Base and Pair of Templar Swords  $\Omega$   
**Assassin's Creed (2016)**

An Apple of Eden and pair of Templar swords from Justin Kurzel's Assassin's Creed. Templars used their swords during their many altercations with Aguilar de Nerha (Michael Fassbender) over the Apple of Eden, an artefact made by a long-lost civilisation, which was later found by Alan Rikkin (Jeremy Irons) in the burial chamber of Christopher Columbus. The swords are made of resin and come with leather scabbards. The base upon which the Apple rests is made of rubber, and the apple itself is made of a translucent resin. The base and Apple are intentionally distressed, and the Apple is in two parts, likely to facilitate the use of lights inside to produce the Apple's glowing effect. The blades of the swords are scuffed and the scabbards exhibit some minor damage. Dimensions (sword): 110 cm x 16.5 cm x 4 cm (43.5" x 6.5" x 1.5") Edged, bladed or blunt object; see notice on Blades in the Buyer's Guide.

**Estimate: £1,000 - 2,000**

**891**  
 Apple of Eden and Chest  $\Omega$   
**Assassin's Creed (2016)**

An Apple of Eden and chest from Justin Kurzel's Assassin's Creed. Sultan Muhammad XII (Khalid Abdalla) was forced to hand over this ancient relic to Torquemada (Javier Gutierrez) in order to save his kidnapped son, but the Apple was soon recaptured by Aguilar (Michael Fassbender). This spherical artefact is made of orange resin covered in engraved markings, with reflective materials added to the core. The chest is made of dark-stained wood with ornately engraved resin panels, hand-painted to replicate worked ivory. The Brotherhood of Assassins emblem is incorporated into the panels' detailed patterns, and a curved insert for the relic is fitted within the chest. Though the lock on the chest is non-functioning, it comes with a key. The lot displays intentional distressing. Dimensions (chest): 30 cm x 17 cm x 20 cm (11.75" x 6.75" x 8")

**Estimate: £3,000 - 6,000**

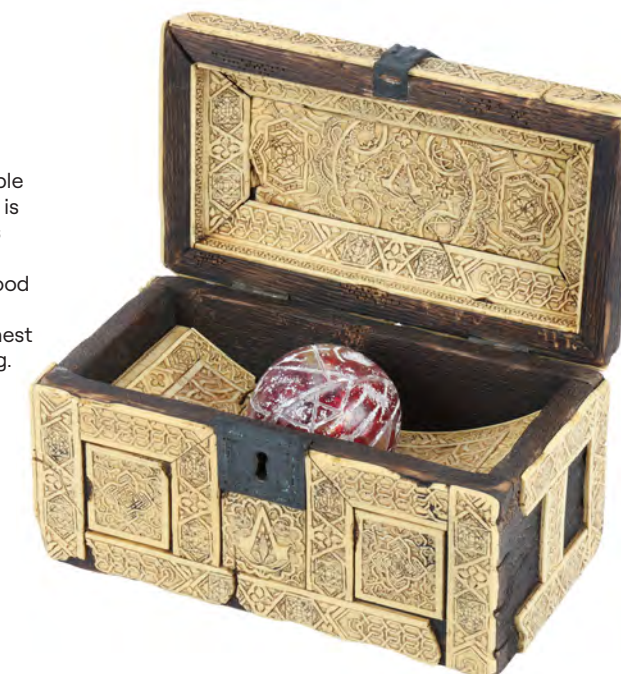

**892**  
 Sir August de Wynter's (Sean Connery) Cane and Three Production Scripts  $\Delta$   
**The Avengers (1998)**

Sir August de Wynter's (Sean Connery) cane and three production Scripts from Jeremiah S. Chechik's sci-fi adventure The Avengers. In the film's finale, Sir August fought with his cane against John Steed (Ralph Fiennes), eerily informing him that it was "time to die". The cane is made from resin, with the shaft painted black to look like wood and the globe handle painted to look like metal. The full-length scripts feature "Mark" or "Mark H" handwritten on their title pages. The lightning bolt detail which previously adorned the globe is no longer present. Dimensions: 155.25 cm x 6 cm x 6 cm (61" x 2.5" x 2.5")

**Estimate: £1,000 - 2,000**



**893**  
 Oh Là Là Magazine Pages  $\Omega$   
**Back To The Future Part II (1989)**

Magazine Oh Là Là pages from Robert Zemeckis' Back to the Future Part II. Marty McFly (Michael J. Fox) went fishing through his principal's trash can to find his stolen sports almanac, only to discover that the cover of the almanac had been used to hide an adult magazine. Included are two sets of four pages of the magazine. The coloured front side of one of the pages features both back and front cover photos of posed, half-dressed women alongside the magazine's title, "Oh Là Là." This cover is printed on magazine stock in full colour and features two model photographs labelled "Le Mois Prochain dans Oh LaLa" and "Oh LaLa No. 29 f4.50", as well as a black-and-white model photograph with credits in French on the reverse. The other set of pages features various black-and-white images of nude models, accompanied by text in French. The nudity has not been censored. Dimensions: 30.5 cm x 23 cm (12" x 9")

**Estimate: £2,500 - 5,000**





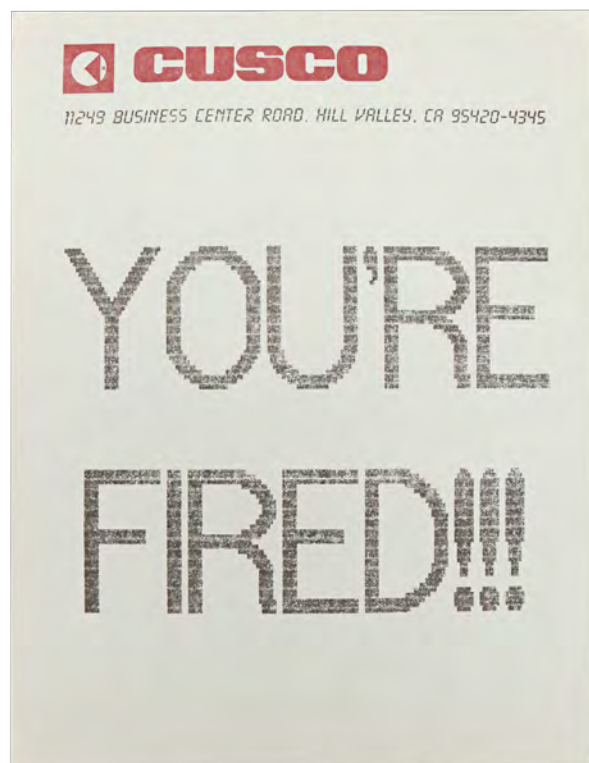

**894**  
CusCo "You're Fired!!!" Fax m  
**Back To The Future Part II (1989)**

A CusCo "You're Fired!!!" fax from Robert Zemeckis' sci-fi adventure sequel Back to the Future Part II. McFly was terminated by Mr. Fujitsu (Jim Ishida) over the phone for making an illegal deal with Needles (Flea), causing termination faxes to appear throughout McFly's house. The fax is accompanied by a Certificate of Authenticity from BTTF.com. Dimensions: 28 cm x 21.5 cm (11" x 8.5")

**Estimate: £3,000 - 6,000**



**895**  
Biffco Enterprises Decals m  
**Back To The Future Part II (1989)**

Two Biffco Enterprises decals from the production of Robert Zemeckis' sci-fi sequel Back to the Future: Part II. The Biffco Enterprises logo was seen throughout the film, including on the napkin that Lorraine (Lea Thompson) used to wipe Marty McFly's (Michael J. Fox) brow when he awoke in an altered reality. The decals, of varying sizes, feature the logo printed on their paper surfaces, which have been covered with plastic. Dimensions: 33 cm x 27 cm (13" x 10.75")

**Estimate: £1,000 - 2,000**



**896**  
Michael J. Fox and Christopher Lloyd-Autographed Replica 2015 Hill Valley Licence Plate m  
**Back To The Future Part II (1989)**

A 2014 Hill Valley licence plate autographed by Michael J. Fox and Christopher Lloyd from Robert Zemeckis' sci-fi comedy sequel Back to the Future Part II. The metal licence plate has been autographed in blue ink by Fox (Marty McFly) and Lloyd (Doc Brown). Dimensions: 15 cm x 30.5 cm (6" x 12") The autographs in this lot have been professionally authenticated by expert Garry King; see notice in the Buyer's Guide.

**Estimate: £500 - 1,000**



**897**  
Hill Valley Police Badge Crew Gift m  
**Back To The Future Part II (1989)**

A Hill Valley Police badge crew gift from the production of Robert Zemeckis' sci-fi sequel Back to the Future Part II. Hill Valley police badges were worn by officers Foley and Reese (Mary Ellen Trainor) when they found Jennifer Parker (Elisabeth Shue) unconscious in an alley. This badge was gifted to Academy Award®-nominated costume designer Joanna Johnston. There is glue residue around the pins and faded handwriting on the back. Dimensions: 8.5 cm x 7 cm x 1 cm (3.25" x 2.75" x 0.5")

**Estimate: £400 - 800**

**898**  
Richard E. Grant's Autographed Cape +  
**Bafta Award Ceremony**

Richard E. Grant's cape from his time hosting the 76th British Academy Film Awards in 2023. Grant made his grand entrance to the awards in a flowing white cape with a high collar. The cape has subsequently been autographed by dozens of attendees, including BAFTA Fellowship winner Sandy Powell, Mad Max: Fury Road actor Rosie Huntington-Whiteley, The Hobbit star Martin Freeman, All Quiet on the Western Front director Edward Berger and Game of Thrones actor David Bradley. The cape features an interior label from Angel Costumes hand-labelled "Richard E Grant BAFTA 2023". It has some minor staining, most notably around the bottom. All hammer price proceeds for this lot will be donated to The British Academy of Film and Television Arts, to support the growth of creative talent in the UK and internationally. Every bid can make a real difference.

**Estimate: £500 - 1,000**



**899**  
UK Quad, Set of Front of House Cards and Press Material m  
**Barbarella (1968)**

A UK Quad poster, a set of Front of House cards and a press material from the release of Roger Vadim's Barbarella. The lot comprises a UK Quad featuring a colourful design by Renato Fratini and Robin Ray, a complete set of eight British front of house lobby cards showing scenes featuring Barbarella (Jane Fonda) and a press synopsis printed onto silver-coloured paper. "Barbarella, 139" is handwritten on the back of the poster, which exhibits multiple fold lines from previous storage, with a small tear along the bottom edge and right edge, and a blue ink mark on the lower right corner. Dimensions: (poster) 74.5 cm x 101 cm (29.25" x 39.75")

**Estimate: £1,000 - 2,000**



**900**  
Two Sets of Playing Cards  $\Delta$   
**Barry Lyndon (1975)**

Two sets of playing cards from Stanley Kubrick's historical drama Barry Lyndon. Card games were a popular pastime for the characters throughout the film. One set comprises 52 cards and comes with its original packet featuring a faux wax seal. The other set contains 40 cards, with each suit missing the 8, 9 and 10 cards. This set comes in a paper envelope. The first set's packet is heavily torn. Dimensions (larger cards): 11 cm x 6 cm (4.25" x 2.25"); (smaller cards): 9.5 cm x 6 cm (3.75" x 2.25")

**Estimate: £600 - 1,200**

**901**  
Pair of Scripts  $\mathfrak{M}$   
**Barry Lyndon (1975)**

A pair of scripts from Stanley Kubrick's period drama Barry Lyndon. The first script has "Memoirs of Barry Lyndon" and the draft date of "Feb 1973" handwritten on its front cover in black ink. Notes handwritten in blue ink are found on the title page. The script is a full-length draft of 111 pages. The second script is an unfinished draft with "Up to date script - 18.1.74" handwritten on its front cover. Its page count is 157, although the print on some pages indicates that certain scenes are yet to be written. Metal pins bind both scripts. Dimensions (one script): 30 cm x 21.25 cm x 2 cm (11.75" x 8.25" x 0.75")

**Estimate: £1,000 - 2,000**

**902**  
Catherine Tramell's (Sharon Stone)  
Set of Three Stunt Ice Picks  $\Omega$   
**Basic Instinct (1992)**

Catherine Tramell's (Sharon Stone) set of three stunt ice picks from Paul Verhoeven's Basic Instinct. Tramell murdered Johnny Boz (Bill Cable) with a wood-handled ice pick, stabbing him first through the nose in the director's cut, only for a different all-metal pick to be discovered under Boz's bed. These three foam rubber stunt picks of varying lengths are painted silver-colour to appear metallic with their grips painted to resemble wood. Each is engraved "LK" on its pommel to resemble monogramming. Also included is a black vinyl-wrapped wooden case with black foam padding. Two of the picks have undergone restoration work, and the pick of middle length exhibits a bent needle from production and age. Dimensions: (largest) 12.75 cm x 9 cm x 4 cm (5" x 3.5" x 1.5")

**Estimate: £3,500 - 7,000**

**903**  
Nick Curran's (Michael Douglas) Police ID  $\mathfrak{M}$   
**Basic Instinct (1992)**

Nick Curran's (Michael Douglas) police ID from Paul Verhoeven's erotic thriller Basic Instinct. At the start of his investigation into the murder of Johnny Boz (Bill Cable), Curran showed his ID to a maid (Irene Olga Lopez) before entering Catherine Tramell's (Sharon Stone). The police ID comprises a metal badge and a laminated identification paper featuring a picture of Curran and the character's signature handwritten in black ink. Dimensions: 18 cm x 12.25 cm x 0.75 cm (7" x 4.75" x 0.25")

**Estimate: £3,000 - 6,000**

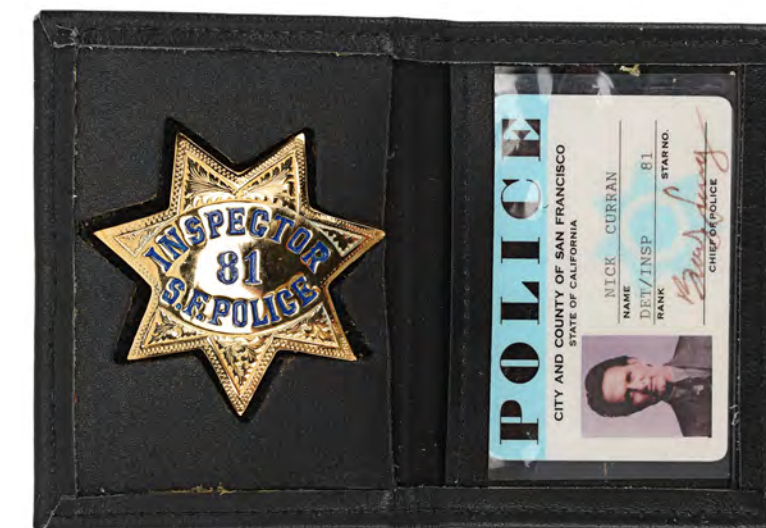

**904**  
Production-made Batman (Michael Keaton)  
Chest Emblem  $\mathfrak{M}$   
**Batman (1989)**

A production-made Batman (Michael Keaton) emblem from Tim Burton's superhero film Batman. While fighting crime and defending Gotham City from the depraved Joker (Jack Nicholson), Batman wore the iconic emblem in the centre of his batsuit's chest. This resin emblem features a raised bat logo painted black against a yellow backing with a raised black edge. The lot exhibits minor scuffs at the top of the emblem's raised edge above the bathead. Dimensions: 15 cm x 11.5 cm x 1 cm (6" x 4.5" x 0.5")

**Estimate: £3,000 - 6,000**



**905**  
Production-made Batman (Michael Keaton) Cowl  $\mathfrak{M}$   
**Batman (1989)**

A production-made Batman (Michael Keaton) cowl from the production of Tim Burton's superhero film Batman. Batman wore his cowl to disguise his identity and intimidate criminals in Gotham City. This black cowl, designed by costume designer Bob Ringwood and sculpted by Batsuit creator Vin Burnham, is the final approved design, but this version ultimately wasn't finished or used for filming. The cowl is made from foam latex and features Batman's iconic pointy ears, with a sculpted brow, scalloped edges and a seam running from the left shoulder to the right over the top of the head. To retain its shape, the cowl has been glued to a black fibreglass shell that is mounted on a metal pole fixed to a black plastic base. Black metal wires support the nose and ears, retaining their structure. The cowl exhibits wear from age and production use, including slight deterioration and creasing of the foam latex. Dimensions: 29 cm x 46 cm x 56.5 cm (11.5" x 18" x 22.25")

**Estimate: £3,000 - 6,000**





**906**  
 Batman (Michael Keaton) Bust m  
**Batman (1989)**

A Batman (Michael Keaton) production bust from Tim Burton's superhero film Batman. The aesthetic of Batman is arguably the most recognisable in the superhero domain. However, with every fresh instalment in the franchise, a new director looks to create their own unique interpretation of the character's iconic look. Batman's original suit was designed by costume designer Bob Ringwood and sculpted by Vin Burnham and co-sculptor Alli Eynon. As part of that design process, busts, such as this one which is made of fiberglass, were created to visualise Burton's proposed costume aesthetic. This allowed Burton to assess concepts before approving the physical creation of the mask and cowl worn by the character. This was Burnham's first sculpt during the design process. Dimensions: 30.5 cm x 63 cm x 54.5 cm (12" x 24.75" x 21.5")

**Estimate: £3,000 - 6,000**

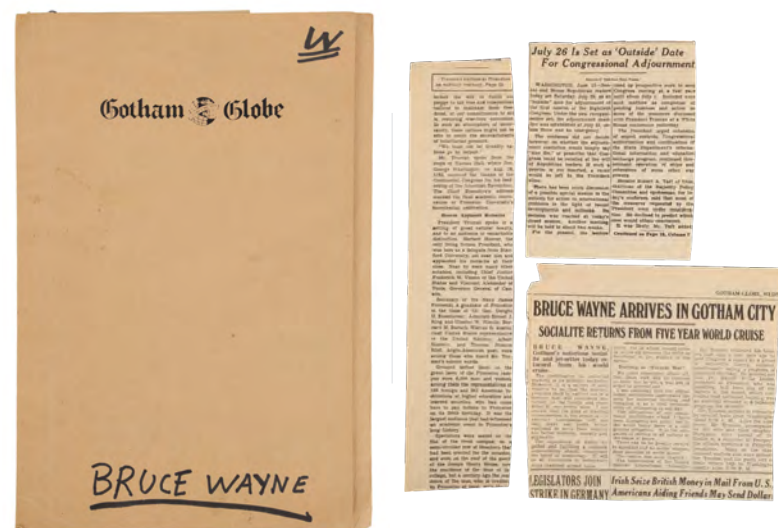

**907**  
 Screen-matched Gotham Globe File Folder for  
 Bruce Wayne m  
**Batman (1989)**

A screen-matched "Bruce Wayne" file folder from Tim Burton's superhero film Batman. Reporter Vicki Vale (Kim Basinger) was handed the folder by Alexander Knox (Robert Wuhl) as she looked for information on Bruce Wayne (Michael Keaton). The hand-written "Bruce Wayne" on the cover matches the one seen on screen. The card file has the Gotham Globe logo printed on the front and "W" handwritten in the top right corner. Inside are three newspaper clippings held together with a paperclip. One is an article on Wayne and the other two are filler articles. The folder exhibits some minor creasing and staining from age and use. Dimensions: 35 cm x 24 cm (13.75" x 9.5")

**Estimate: £3,000 - 6,000**



**908**  
 City Of Gotham Licence Plate m  
**Batman (1989)**

A City of Gotham licence plate from Tim Burton's superhero film Batman. Though not obviously seen on screen, the plate features white raised text reading "A94 1NJ" over a purple and grey background that features the Gotham City skyline and text reading "CITY OF GOTHAM". The plate is made of metal, and bordered by solid resin detailing that has been painted gold. Dimensions: 31.5 cm x 16.5 cm x 1 cm (12.5" x 6.5" x 0.5")

**Estimate: £500 - 1,000**

**909**  
 Pair of David Russell Hand-drawn  
 Batmobile Concept Sketches m  
**Batman (1989)**

A pair of David Russell hand-drawn batmobile concept sketches from the production of Tim Burton's Batman. Batman (Michael Keaton) rescued Vicki Vale (Kim Basinger) from the Joker (Jack Nicholson), fleeing the scene with her in his batmobile. These sketches are rendered in ink and paint by eminent production artist David Russell, who also illustrated the film's storyboards. The drawings depict a batmobile style slightly different from the final piece seen on screen. Russell has hand-signed both sketches below the image. His work also contributed to the success of many other iconic films, including Star Wars: Return of the Jedi, Terminator 2: Judgement Day, Empire of the Sun, and many more. Dimensions: 34 cm x 28 cm (13.50" x 11") Sold without copyright; see copyright notice in the Buyer's Guide.

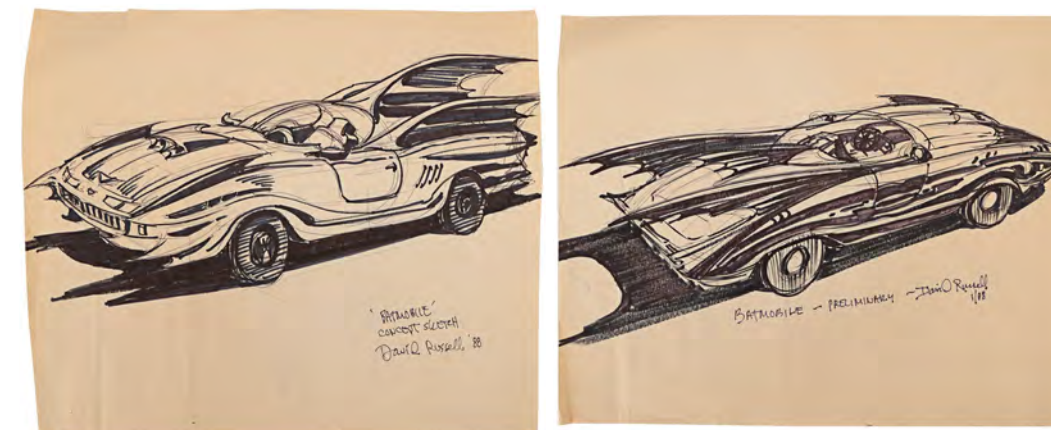

**Estimate: £3,000 - 6,000**

**910**  
 Jack Nicholson Crew Gift Statue and Head of  
 Department Leather Crew Jacket m  
**Batman (1989)**

A Jack Nicholson crew gift statue and a Head of Department leather crew jacket from the production of Tim Burton's superhero film Batman. The crew gift statue is made of resin, presented on a wooden base with a purple felt underside, and depicts Nicholson's character, Joker, in his full costume. The jacket is a size "M" with a Batman emblem badge on one sleeve and a Joker's Goons gang badge on the other. The statue has been refinished and repaired at the point where his hand meets his hat. Dimensions (statue): 10 cm x 36.5 cm x 43.5 cm (4" x 14.25" x 17.25")

**Estimate: £1,000 - 2,000**



**911**  
 Light-up Toynami Batwing Replica m  
**Batman (1989)**

A Toynami replica of the Batwing from Tim Burton's superhero film Batman. While piloting his Batwing, Batman (Michael Keaton) successfully prevented the Joker (Jack Nicholson) from dosing the citizens of Gotham with Smylex. This Toynami replica lights up through its headlights, control panel screens, and a light on its underside. These lights illuminate when the Batwing is secured on its accompanying stand, connected to power via the mains lead. The stand can also operate as a wall mount. The replica comes with its original packaging. Dimensions: 59 cm x 70 cm x 36 cm (23.25" x 27.5" x 14.25") Contains electronics; see electronics notice in the Buyer's Guide.

**Estimate: £1,000 - 2,000**





77 cm (30.25")

**912**  
Light-up Toynami Batmobile  
Replica M  
**Batman (1989)**

A Toynami replica of the Batmobile from Tim Burton's Batman. Batman (Michael Keaton) rescued Vicki Vale (Kim Basinger) from the Joker (Jack Nicholson), fleeing the scene with her in his batmobile. The Batmobile's roof can be slid forward, revealing the cockpit-like interior. The gear stick can be switched to two different light display settings for the headlights, breaklights and exhaust. The replica is displayed loosely on a stand, although its functioning rubber wheels mean it can be pushed along. It is accompanied by its original packaging. Dimensions: 77 cm x 38.5 cm x 20.5 cm (30.25" x 15.25" x 8") Contains electronics; see electronics notice in the Buyer's Guide.

**Estimate: £1,500 - 3,000**



**913**  
Production-made Batman (Michael Keaton)  
Chest Emblem M  
**Batman Returns (1992)**

A production-made Batman (Michael Keaton) emblem from Tim Burton's superhero sequel Batman Returns. As he defended Gotham City against the depraved activities of Penguin (Danny DeVito), Batman wore the iconic emblem in the centre of his batsuit's chest. This resin emblem features a raised bat logo painted black against a yellow backing with a raised black edge. The lot exhibits patches of yellow dots on the raised bat logo due to the overcoat of black paint wearing slightly. Dimensions: 15 cm x 11.5 cm x 1 cm (6" x 4.5" x 0.5")

**Estimate: £3,000 - 6,000**



**914**  
Screen-matched Thin Clown (Doug Jones)  
Bomb Planting Headset M  
**Batman Returns (1992)**

Screen-matched Thin Clown (Doug Jones) bomb planting head set from Tim Burton's superhero sequel Batman Returns. The headset matches the one seen on screen by distinctive markings on the surface of its band and the rim of the light. The Thin Clown was seen planting bombs while Batman (Michael Keaton) was lured to a rooftop by Penguin (Danny DeVito) and Catwoman (Michelle Pfeiffer).

The headset comprises a metal band with a foam surface on its inner side for comfort, and it features a handwritten "Thin" label stuck to it. A dormant power source and switch at the rear are connected to the small bulb at the front, while the spiralling metal rod was used to hold bomb parts. Dimensions: 67 cm x 21 cm x 36 cm (26.5" x 8.25" x 14.25")

Contains electronics; see electronics notice in the Buyer's Guide.

**Estimate: £2,000 - 4,000**



**915**  
Max Shreck's (Christopher Walken)  
Tuxedo M  
**Batman Returns (1992)**

Max Shreck's (Christopher Walken) tuxedo from Tim Burton's superhero sequel Batman Returns. Shreck wore his tuxedo during the film's climax, when he was kidnapped at his charity ball by Penguin (Danny DeVito) and later electrocuted to death by Catwoman (Michelle Pfeiffer) in the Arctic Exhibit. The lot includes a jacket with a chest size of "42" and a sleeve length of "18"; a pair of matching trousers with a waist size of "35 1/2"; and an intricately patterned waistcoat with a chest size of "42". Labels with "Western Costume Co." are sewn into the items' interiors, stating Walken's name.

**Estimate: £3,000 - 6,000**



**916**  
Catwoman's (Michelle Pfeiffer)  
Bodysuit M  
**Batman Returns (1992)**

Catwoman's (Michelle Pfeiffer) bodysuit from Tim Burton's superhero sequel Batman Returns. Having survived Max Shreck's (Christopher Walken) attempt to murder her, Selina Kyle was reborn as Catwoman and donned her costume to seek vengeance against Shreck by any means necessary. The black latex zip-up bodysuit features white stitching applied throughout, purposefully left open in places to reveal pale pink latex that simulated skin. The latex has deteriorated over time rendering the costume in an extremely fragile state. The suit should be handled with care and should not be worn.

**Estimate: £2,000 - 4,000**



**917**  
Oswald Cobblepot Dummy Body  
Head and Hands M  
**Batman Returns (1992)**

An Oswald Cobblepot dummy body head and hands from Tim Burton's Batman Returns. After his death, the body of Oswald Cobblepot (Danny DeVito) was ceremoniously walked by his penguin companions into the waters of the Arctic exhibit of the Gotham Zoo, where it sank to dark depths below. This lot consists of a painted latex foam skin with a taped back opening, pointed nose, and full lips mounted on a black foam mannequin head with painted eyes; and a pair of painted latex foam "flipper" hands with brown resin fingernails and metal armatures to keep them in place. The head and hands exhibit extensive flaking and cracking material with some signs of sympathetic repairs.

**Estimate: £2,000 - 4,000**



**918**  
 Batman's (Val Kilmer) Sonar Torso Armour  $\Omega$   
**Batman Forever (1995)**

Batman's (Val Kilmer) sonar torso armour from Joel Schumacher's *Batman Forever*. After the Riddler (Jim Carrey) destroyed all of Batman's standard batsuits in the Batcave, Batman donned his experimental sonar batsuit for their final confrontation. This black torso armour is made of moulded foam rubber and features sculpted muscles and detailing on the chest, shoulders, upper back, and abdomen; with a large bat emblem across the chest. The inside of the armour is marked "102." The foam rubber exhibits some tears, most notably on the shoulders.

**Estimate: £2,000 - 4,000**



**919**  
 Batgirl's (Alicia Silverstone) Arctic Utility Belt  $\Omega$   
**Batman & Robin (1997)**

Batgirl's (Alicia Silverstone) arctic utility belt from Joel Schumacher's *Batman & Robin*. Batgirl wore her arctic costume when she, Batman (George Clooney), and Robin (Chris O'Donnell) fought Mr. Freeze (Arnold Schwarzenegger) and Bane (Jeep Swenson) on the ice. Designed by Ingrid Ferrin, Robert Turturice, and Bob Ringwood and sculpted by Jose Fernandez, this belt featuring the Batman emblem on front is constructed from rubber, hand-painted silver-colour, and padded on the reverse with black velvet and five fastening strips. It features a black plastic clip with a nylon strap. The belt exhibits yellow stains on top and around one fastening strip with red residue on the other strips from production wear.

**Estimate: £1,000 - 2,000**



**920**  
 Bruce Wayne's (Christian Bale) Stunt League of Shadows Gauntlets  $\Omega$   
**Batman Begins (2005)**

A pair of Bruce Wayne's (Christian Bale) stunt League of Shadows gauntlets from Christopher Nolan's crime-drama *Batman Begins*. Bruce Wayne wore a pair of bladed gauntlets, like other members of the League of Shadows, as he fought Ducard (Liam Neeson) during a training exercise on a frozen lake. The main body of each gauntlet is resin, while the jagged blades are rubber. They are fastened along one side with hidden velcro. Handwritten "Neil Finnighan Stunt" labels are found inside each gauntlet. Finnighan is a credited stunt performer on the production. Some of the blades exhibit minor bending from production use. Dimensions (one gauntlet): 25.5 cm x 19 cm x 13 cm (10" x 7.5" x 5")

**Estimate: £750 - 1,500**

**921**  
 Pair of Gotham Manhole Covers  $\Omega$   
**Batman Begins (2005)**

Gotham manhole covers from Christopher Nolan's superhero film *Batman Begins*. The Scarecrow (Cillian Murphy) released a fear-inducing hallucinogen into the streets of Gotham through the water system, in turn blowing off manhole covers all over the city. Included in this lot are a painted and an unpainted manhole cover, both made of Styrofoam. Both covers exhibit some damage. Dimensions: 60 cm x 60 cm x 20 cm (23.75" x 23.75" x 8")

**Estimate: £600 - 1,200**



**922**  
 Batman's (Christian Bale) Tumbler Spoiler  $\Omega$   
**Batman Begins (2005)**

Batman's (Christian Bale) Tumbler spoiler from Christopher Nolan's *Batman Begins*. Batman helped Rachel Dawes (Katie Holmes) escape from Scarecrow's (Cillian Murphy) clutches, then evade Gotham PD, in the Tumbler customised for him by Lucius Fox (Morgan Freeman). Designed to be fitted to the outside edge of the vehicle's right rear corner by production designer Nathan Crowley in coordination with Nolan, this spoiler is constructed from sheet metal screwed around an internal support and finished in Batman's distinctive matte black. It features an open notch through one edge for affixing an aerial, as well as seven glossy winged details applied to the top. The spoiler exhibits some denting, paint flaking, and stains from handling. Dimensions: 94 cm x 31.75 cm x 5 cm (37" x 12.5" x 2")

**Estimate: £3,000 - 6,000**



**923**  
 Gotham Manhole Cover  $\Omega$   
**Batman v Superman: Dawn Of Justice (2016)**

A Gotham manhole cover from Zack Snyder's *Batman v Superman: Dawn of Justice*. Manhole covers lined the streets of Gotham City throughout the film as Batman (Ben Affleck) attempted to gain control of Superman (Henry Cavill) and prevent an impending apocalypse. Made of foam and fibreglass, this manhole cover has "Gotham City" embossed across the centre with "1635" beneath it. It features strategic openings to allow steam to rise from the sewers below, while the entire cover is finished in a metallic black finish to resemble cast iron. This lot exhibits discolouration, raw edges, and pitting from the curing process. Dimensions: 64.75 cm x 64.75 cm x 4 cm (25.5" x 25.5" x 1.5) Edged, bladed or blunt object; see notice on Blades in the Buyer's Guide.

**Estimate: £1,500 - 3,000**





**924**  
 Police Badge and Evidence Ticket, Wayne Enterprises Labels, Gotham Number Plate and Promotional Bill †Δ  
**The Dark Knight (2008)**

A collection of props and promotional materials from Christopher Nolan's superhero sequel The Dark Knight. Gotham Police badges were worn on officers' jackets throughout the film, including during the parade, with the Joker (Heath Ledger) also wearing one while in disguise. The evidence ticket was designed to contribute towards the overall set design of Gotham Police Station. Plastic Gotham City number plates were seen on vehicles driving throughout the city's streets. The five-dollar bill features hand-drawn and handwritten pink doodling on both sides. Dimensions (number plate): 30.5 cm x 15.5 cm x 0.75 cm (12" x 6.25" x 0.25")

**Estimate: £1,000 - 2,000**



**925**  
 Prototype Utility Belt Gadgets †Δ  
**The Dark Knight (2008)**

Prototype utility belt gadgets from the production of Christopher Nolan's superhero sequel The Dark Knight. Batman (Christian Bale) used various gadgets throughout the series, and notably used a drill to extract bullet fragments from a wall to find a fingerprint. Both prototypes are primarily made of aluminium, although the drill tip is made of steel. The cap on the dual-cylinder prototype opens. The pieces have some markings and the drill bit has some rust. Dimensions (drill gadget): 15 cm x 3.5 cm x 3 cm (6" x 1.25" x 1.25")

**Estimate: £500 - 1,000**

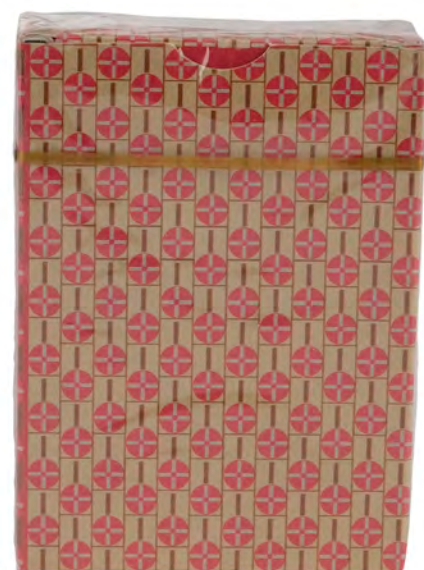

**926**  
 Complete Viral Deck of Joker (Heath Ledger) Cards Ω  
**The Dark Knight (2008)**

A complete "viral deck" of Joker (Heath Ledger) cards from the promotion of Christopher Nolan's The Dark Knight. 42 Entertainment and DC Comics released production-made decks of Joker's unique calling cards as part of its viral marketing campaign. Some decks were also given to members of the team responsible for the film's advertising campaign. These 47 specialty playing cards, an extremely rare, complete set, are printed on textured semi-gloss cardstock and labelled either "Joker" or "J." Each features a distinct pattern on one side and a character image on the other, including gargoyles, dragons, and clowns, among others. The cards come wrapped with plastic inside their original cardboard box. The plastic exhibits minor tearing. Dimensions: 6.75 cm x 9 cm x 1.5 cm (2.75" x 3.5" x 0.5")

**Estimate: £2,000 - 4,000**

**927**  
 Bruce Wayne's (Ben Affleck) Gucci Suit Jacket and Waistcoat †Δ  
**Batman v Superman: Dawn Of Justice (2016)**

Bruce Wayne's (Ben Affleck) Gucci® suit jacket and waistcoat from Zack Snyder's superhero film Batman v Superman: Dawn of Justice. Wayne wore his jacket and waistcoat at a fundraiser held by Lex Luthor (Jesse Eisenberg), where he attempted to retrieve encrypted data from LexCorp. The lot comprises a custom-made woollen jacket and matching waistcoat featuring a rayon-silk lining. Both garments are marked as size 7-60 L, and a label underneath the jacket's inside right pocket reads "Gucci Made to Measure Bruce Wayne". An additional label on the waistcoat lining displays handwritten text reading "Milo BP". The lining fabric exhibits minor creasing, and the original Gucci tag comes with the lot.

**Estimate: £1,000 - 2,000**



**928**  
 Set of Three Bruce Wayne (Ben Affleck) Gucci Monogrammed Shirts †Δ  
**Batman v Superman: Dawn Of Justice (2016)**

A set of three Bruce Wayne (Ben Affleck) Gucci monogrammed shirts from Zack Snyder's superhero film Batman v Superman: Dawn of Justice. Wayne wore a grey shirt while watching Senate Committee Hearings on CNN and a dark navy shirt when he received an invite to Lex Luthor's (Jesse Eisenberg) house. The blue shirt doesn't appear on-screen in the final cut.

**Estimate: £500 - 1,000**



**929**  
 Batarang M  
**Justice League (2017)**

A batarang from Zack Snyder's superhero film Justice League. Batman (Ben Affleck) used batarangs as one of his primary weapons and threw one at Barry Allen (Ezra Miller) so he would out himself as The Flash. The black resin batarang has silver-painted edges and minor paintwear. Dimensions: 9 cm x 20.5 cm x 0.5 cm (3.5" x 8" x 0.25")

**Estimate: £2,000 - 4,000**



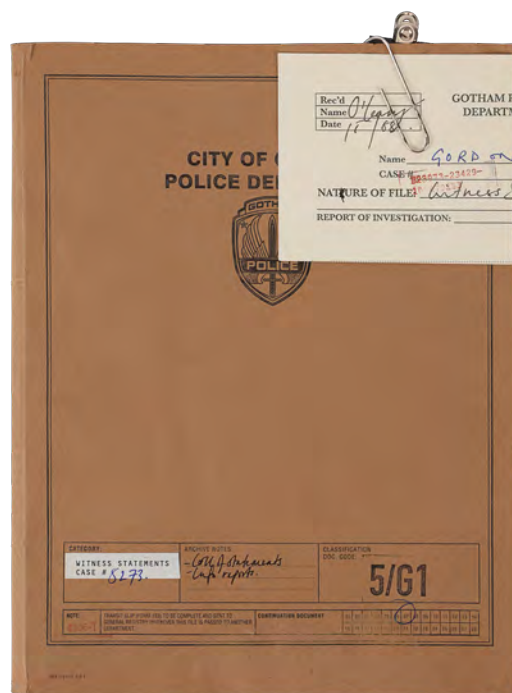

**930**  
 Commissioner Gordon's  
 (J.K. Simmons) Police File m  
 Justice League (2017)

Commissioner Gordon's (J.K. Simmons) police file from Zach Snyder's superhero film Justice League. Gordon showed his file detailing several abductions by Steppenwolf's Parademons to the Justice League superheroes when he met them on a rooftop.

The file features several pages of printed police reports and a page with a printed sketch of a Parademon. The pages are held in place with a bulldog clip and paper clips. Dimensions: 30.5 cm x 23.5 cm x 1 cm (12" x 9.25" x 0.5")

**Estimate: £1,000 - 2,000**



**931**  
 Batman's (Ben Affleck) Grapple Gun Ω  
 Batman v Superman: Dawn Of Justice (2016)

Batman's (Ben Affleck) grapple gun from Zack Snyder's Batman v. Superman: Dawn of Justice. During his epic battle against Superman (Henry Cavill), Batman threw Superman down various floor levels of an abandoned building and used his grapple gun to descend to the same level. Composed of resin painted in silver-colour and black to resemble metal with a grip painted in shades of brown to resemble wood, this static grapple gun features a high-tech design with a textured barrel and a circular spool at the back of the barrel. One side of the grapple gun has a two-pronged grip attached. This lot exhibits chipped and flaked paint, as well as mild discolouration and pitting from the moulding process. Dimensions: 31.25 cm x 23 cm x 7.75 cm (12.25" x 9" x 3")

**Estimate: £3,000 - 6,000**



**932**  
 Detective Comics No. 493 with Adrienne Roy Hand-  
 Coloured "Riddles in the Dark" Interior Colour Guides m  
 Batman Comics

A comic book with 17 hand-coloured pages from the DC Comics Detective Comics series. Included in this lot is a printed copy of issue 493, published in August 1980, as well as the original colour guides for the "Riddles in the Dark" story, which is the first story featured in the issue. The 17 hand-coloured pages display the full story and have been coloured using watercolour paints and annotated with the shade name of each colour. The colourist credited is Adrienne Roy and some of the pages have been incorrectly numbered. The comic book is a 68-page giant, and contains a 17-page Batman story, a 9-page Tales of Gotham, an 8-page Robin story, a 9-page Human Target story, and an 8-page Batgirl story. Some of the pages exhibit red-coloured marks. Dimensions: 28 cm x 20 cm (11" x 8") Sold without copyright; see notice in the Buyer's Guide.

**Estimate: £500 - 1,000**

**933**  
 DC Comics No. 341 with Adrienne Roy Hand-Coloured  
 "The Ghost of Wayne Manor" Interior Colour Guides m  
 Batman Comics

A comic book with 17 hand-coloured pages from the DC Comics series. Included in this lot is a printed copy of issue 341, published in November 1981, as well as the original colour guides for "The Ghost of Wayne Manor", which is the first story featured in the issue. The hand-coloured pages display, which comprises the full 17-page story, have been coloured using watercolour paints and annotated with the shade name of each colour. The colourist credited is Adrienne Roy. The comic is 36 pages long and features a 17-page Batman story, a 2-page 'Just a Moment Mystery' story, and an 8-page Robin story. Some of the coloured pages feature minor tears, but otherwise the items remain in very good condition. Dimensions: 28 cm x 20 cm (11" x 8") Sold without copyright; see notice in the Buyer's Guide.

**Estimate: £500 - 1,000**



**934**  
 Detective Comics No. 486 with Adrienne Roy  
 Hand-Coloured "Murder by Thunderbolt" Interior  
 Colour Guides M  
**Batman Comics**

A comic book with 17 hand-coloured pages from the DC Comics Detective Comics series. Included in this lot is a printed copy of issue 486, published in October and November 1979, as well as the original colour guides for the "Murder by Thunderbolt" story, which is the first story featured in the issue. The hand-coloured pages have been coloured using watercolour paints, and annotated with the shade name of each colour. The colourist credited is Adrienne Roy. The comic book is a 68-page giant and contains a 17-page Batman story, an 8-page Human Target story, an 8-page Batgirl story, a 7-page Alfred story, and a 12-page Robin story. Dimensions: 28 cm x 20 cm (11" x 8") Sold without copyright; see notice in the Buyer's Guide.

**Estimate: £500 - 1,000**



**935**  
 Detective Comics No. 487 with Adrienne Roy Hand-  
 Coloured "The Perils of Sergius" Interior Colour Guides M  
**Batman Comics**

A comic book with 17 hand-coloured pages from the DC Comics Detective Comics series. Included in this lot is a printed copy of issue 487, published in December 1979 and January 1980, as well as the original colour guides for the "The Perils of Sergius" story, which is the first story featured in the issue. The hand-coloured pages, which comprise the full 17-page Batman story, have been coloured using watercolour paints and annotated with the shade name of each colour. The colourist credited is Adrienne Roy. The comic book is a 68-page giant and contains a 17-page Batman story, a 6-page Roy Raymond TV Detective story, a 10-page Robin story, an 8-page Odd Man story, and a 10-page Batgirl story. Dimensions: 28 cm x 20 cm (11" x 8") Sold without copyright; see notice in the Buyer's Guide.

**Estimate: £500 - 1,000**



**936**  
 Cylon Armour Parts Ω  
**Battlestar Galactica (T.V. Series, 1978-1979)**

A set of Cylon armour parts from the sci-fi TV series Battlestar Galactica. The Cylons wore their armour as they sought to exterminate the human race. The lot comprises three wrist guards, two upper arm rings, and one belt block, all made from vacuum-formed plastic. One of the wrist guards is finished in gold rather than silver, as it was part of a rarer Cylon of that tone seen on screen. "Right" is marked inside one of the wrist guards in black marker pen. Dimensions: 21 cm x 10.5 cm x 13 cm (8.25" x 4.25" x 5")

**Estimate: £1,000 - 2,000**

**937**  
 Adam Maitland's (Alec Baldwin)  
 Scary Face Replica Ω  
**Beetlejuice (1988)**

A replica of Adam Maitland's (Alec Baldwin) scary face from Tim Burton's Beetlejuice. Adam and his wife Barbara (Geena Davis) transformed into horrific monsters to scare off the Deetz family and retrieve the handbook of the dead after Otho (Glenn Shadix) took it from the attic. Created by the film's special effects artist Robert Short, this replica head is made of latex skin over a foam core with an exaggerated sculpt of a long nose with an overbite, four fingers protruding through the back of the head, and various stretch lines. It was painted in various flesh tones to resemble skin with white teeth, and blackened eye sockets to appear as if they were empty. Brown curly synthetic hair is attached to the back of the head. This lot exhibits discolouration on the underside of the head, a buildup of grime, and frayed hair fibres. Dimensions: 76.25 cm x 25.5 cm x 33 cm (30" x 10" x 13")

**Estimate: £4,000 - 8,000**



**938**  
 Script, Production Photos and Paperwork Ω  
**Beetlejuice (1988)**

A script, production photos, and paperwork from Tim Burton's Beetlejuice. Married couple Adam (Alec Baldwin) and Barbara Maitland (Geena Davis) found themselves dead after a car accident and discovered their home now owned by the Deetz family, which left them to conduct all means necessary to remove them, including seeking help from the bio-exorcist Beetlegeuse (Michael Keaton). This lot consists of 28-page, green second draft script used by propmaker foreman John Villarino dated February 3, 1987; an eight-page goldenrod contact list with handwritten annotations on the front; a printed call sheet dated June 1, 1987; and 40 colour print behind-the-scenes photos. This lot exhibits discolouration, stains, and loose pages on the list and script. Dimensions: (largest) 21.75 cm x 35.75 cm (8.5" x 14")

**Estimate: £1,500 - 3,000**



**939**  
 Benny Hill Hat and Photo M  
**The Benny Hill Show (T.V. Series, 1969-1989)**

A Benny Hill hat and photo from The Benny Hill Show. This grey wool hat has an interior Berman & Nathans label with Hill's name and the production title printed on it. The hat is also labelled as size "large". The hat is accompanied by a framed photograph of Hill posing with the hat and a group of men and women.

**Estimate: £500 - 1,000**





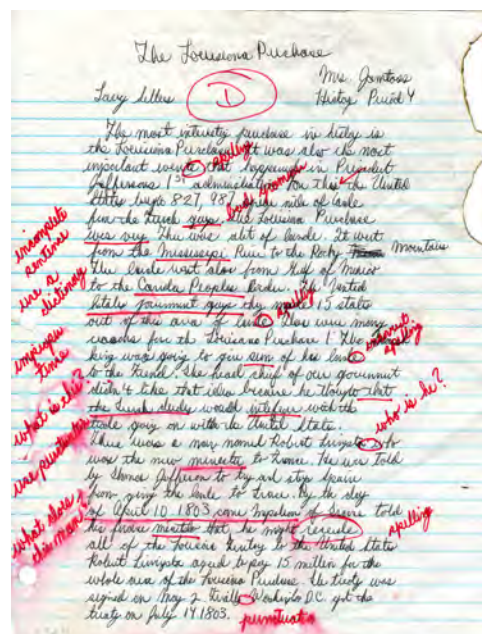

940 Larry Sellers' (Jesse Flanagan) Screen-matched Handwritten Homework  $\Omega$  The Big Lebowski (1998)

Larry Sellers' (Jesse Flanagan) screen-matched handwritten homework from Joel and Ethan Coen's The Big Lebowski. Walter Sobchak (John Goodman) confronted Sellers with the homework he left in The Dude's (Jeff Bridges) car after allegedly robbing it. Distinctive flourishes in the handwriting on this homework screen-match to close-up inserts in the film. This lot consists of an essay titled "The Louisiana Purchase" and authored by "Larry Sellers" handwritten in black ink with a "D" grade and various corrections made in red ink on hole-punched and lined U.S. letter-size paper. The paper exhibits intentional distressing by production to appear damaged with liquid stains and burns along the edges. Dimensions: 21.75 cm x 28 cm (8.5" x 11") Sold without copyright; see notice in the Buyer's Guide.

Estimate: £2,500 - 5,000

941 Collection of ID Cards with Intercom, Briefcase, Wallet, and Towel  $\Omega$  Big Little Lies (T.V. Series, 2017-2019)

A collection of ID cards with intercom, briefcase, wallet, and towel from the television series Big Little Lies. This lot consists of five California driver's licences for the main cast; a plastic intercom with a dial and toggle switch; a patterned blue cotton towel; a faux leather carpet wallet; and one genuine leather messenger bag briefcase with Avenue Q folders. This lot exhibits discoloration, chipped paint, and flaked faux leather. Dimensions: (largest) 51 cm x 35.5 cm x 15.25 cm (20" x 14" x 6") Contains electronics; see electronics notice in the Buyer's Guide.

Estimate: £800 - 1,600

942 Mike Donnelly's (Chris Farley) Coat  $\Omega$  Black Sheep (2007)

Mike Donnelly's (Chris Farley) coat from Penelope Spheeris' Black Sheep. Mike wore his button-covered campaign coat as he stood outside the store with Steve Dodds (David Spade) and passed out buttons to passersby. This lot consists of a maroon polyester Palm Beach Eagleson's coat with a total of 12 blue vinyl and metal pins sewn throughout featuring Al Donnelly (Tim Matheson) for his campaign for governor race. This coat exhibits a torn front bottom left pocket, as well as minor bending to some of the pins.

Estimate: £2,000 - 4,000



943 "Captain Cook" and "Major Star" Shooting Scripts  $\Omega$  Blackadder (T.V. Series, 1982)

Two shooting scripts from the iconic British sitcom Blackadder. The first script is for the first episode of the 'Blackadder Goes Forth' series, titled "Captain Cook". The second script is for the third episode from the same series, titled "Major Star". This script features handwritten notes and highlighting on the title page. The first script exhibits stains on its title page. Dimensions (one script): 30 cm x 21.25 cm x 1.25 cm (11.75" x 8.25" x 0.5")

Estimate: £400 - 800



944 "Spy" Production Script With Special Final Scene and Rowan Atkinson and Key Cast and Crew Autographs  $\Omega$  Blackadder Goes Forth - General Hospital (1989)

A "Spy" production script with a special final scene from the production of the BBC historical sitcom Blackadder Goes Forth. The script is a 71-page production script for the series' fifth episode, interestingly titled "Spy", though it eventually aired as "General Hospital". Despite not being the final episode, the script's last page features the legendary final scene of the series, involving Blackadder (Rowan Atkinson) going "over the top" with his comrades. The autographs, obtained when filming wrapped, are from cast members Rowan Atkinson, Tony Robinson, Stephen Fry, Hugh Laurie, Tim McInnerny and co-writer Richard Curtis. They are all written in blue ink on the back of an invitation to the recording of the episode. Dimensions (script): 30 cm x 21.5 cm x 1 cm (11.75" x 8.5" x 0.25") The autographs in this lot have been professionally authenticated by expert Garry King; see notice in the Buyer's Guide.

Estimate: £2,000 - 4,000

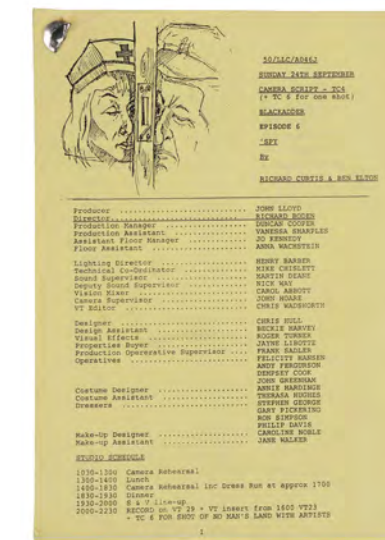

945 Edmund Blackadder's (Rowan Atkinson) "Potato" Boomerang  $\Omega$  Blackadder II - Potato (1986)

A boomerang from "Potato", the third episode of the second series of the BBC sitcom Blackadder. Blackadder (Rowan Atkinson) presents the Queen (Miranda Richardson) a 'special stick' as a souvenir from his travels, that when thrown away, comes back. She is displeased with the gift until she witnesses a throw of the boomerang return and strike Percy (Tim McInnerny) in the back of the head. The boomerang is made of foam latex, painted to look wooden. The boomerang has become fragile with age, and cracked in a number of places. It has been reinforced with steel wire and felt on the underside, but it should still be handled with care. Dimensions: 53 cm x 10 cm x 1 cm (21" x 4" x 0.5")

Estimate: £1,000 - 2,000





**946**  
Blade's (Wesley Snipes) Aluminium Stake  $\alpha$   
**Blade (1998)**

Blade's (Wesley Snipes) aluminium stake from Stephen Norrington's Blade. The half-vampire "Daywalker" wore metal stakes in a bandolier around his left thigh throughout the movie, notably as he pinned Quinn (Donal Logue) to a wall with two before setting him alight. This stake is made of aluminium and displays a chromed silver-colour finish. An indented line adorns the top and the opposite end is pointed. It exhibits signs of wear from use and age, including scratching throughout the finish. Dimensions: 2.75 cm x 2.75 cm x 24.25 cm (1" x 1" x 9.5")  
Edged, bladed or blunt object; see notice on Blades in the Buyer's Guide.

**Estimate: £1,000 - 2,000**

**947**  
Reinhardt's (Ron Perlman) Screen-matched  
Tactical Stake Shotgun us  
**Blade II (2002)**

Reinhardt's (Ron Perlman) screen-matched tactical stake shotgun from Guillermo del Toro's Blade II. Reinhardt carried and used his shotgun as he worked with the other Bloodpack operatives and Blade (Wesley Snipes) to eliminate the Reaper hybrid vampires. Wear points on the pump slide and scratches on the right side of the shotgun match to the scene just before Reinhardt faces off against Blade for one last time in the nursery.

Based on a Remington 870 shotgun, this lot has been modified with a machined metal barrel, black pistol grip, a tactical light, and a static stake launcher. The stake launcher is made of machined aluminium. The shotgun also features a moveable pump grip, trigger, safety, and shell port. It has a serial number V951462V. This lot exhibits some scuffing to the metal finish, chipped paint, and a buildup of grime on the interior, while the light has been fixed in place, rendering it currently nonfunctional. Dimensions: 78.75 cm x 10.25 cm x 28 cm (31" x 4" x 11")

Firearm deactivated; see firearm deactivation notice in the Buyer's Guide.

Restricted ownership; see replica firearm notice in the Buyer's Guide.

Contains electronics; see electronics notice in the Buyer's Guide.

Edged, bladed or blunt object; see notice on Blades in the Buyer's Guide.

Additional Provenance: BAPTY Certificate of De-Activation.

**Estimate: £4,000 - 8,000**



**948**  
Reinhardt's (Ron Perlman) Bladed Pistol with  
Screen-matched Magazine us  
**Blade II (2002)**

Toro's Blade II. Reinhardt carried and used his signature bladed pistols when he worked with the other Bloodpack operatives and Blade (Wesley Snipes) to eliminate the Reaper hybrid vampires. Unique wear present on the base of this magazine screen-match to shots of it inserted into Reinhardt's distinctive weapon throughout the film.

Based on Beretta 92FS pistols, this lot was modified with a custom resin pistol grip designed to resemble bound katana grips. It has a machined aluminium slide, magazine, and blade. Japanese lettering was engraved on the sides of the blades and the slide components and painted black. The grips are finished in black-and-white paint. The weapon also features a moveable slide, magazine release, hammer, and trigger. It has a serial number for F52882Z. This lot exhibits some scuffing to the metal finish and chipped paint. Dimensions: 29.25 cm x 18 cm x 5 cm (11.5" x 7" x 2")

Firearm deactivated; see firearm deactivation notice in the Buyer's Guide.

Edged, bladed or blunt object; see notice on Blades in the Buyer's Guide.

Blade was dulled by production.

Additional Provenance: BAPTY Certificate of De-Activation.

**Estimate: £3,000 - 6,000**



**949**  
Blade's (Wesley Snipes)  
Unitard  $\alpha$   
**Blade: Trinity (2004)**

Blade's (Wesley Snipes) unitard from David S. Goyer's superhero film Blade: Trinity. Blade wore his unitard as part of his full costume ensemble when he rescued Hannibal (Ryan Reynolds) towards the end of the film. The unitard is red, with black designs printed on the collar and sleeves.

**Estimate:**  
**£1,000 - 2,000**



**950**  
Abigail Whistler's (Jessica Biel)  
Costume  $\alpha$   
**Blade: Trinity (2004)**

Abigail Whistler's (Jessica Biel) costume from David S. Goyer's Blade: Trinity. A member of the vampire-hunting team of humans known as the Nightstalkers, Whistler wore her costume when she teamed with daylight-adaptable vampire Blade (Wesley Snipes) to battle a resurrected Dracula (Dominic Purcell) and his murderous army of the night. This costume consists of a black and red leatherette and nylon zippered vest marked "Hero 1" on the interior; a dark grey cotton waffle-patterned long-sleeve thermal stunt shirt marked "Alyssa Mutch" on the interior tag; a black Nike sports bra; a pair of stunt gloves (Size M) marked "Trevor"; dark grey corduroy trousers; a black faux leather gun holster with belt; and black leather and rubber boots. The costume exhibits a buildup of grime on the boot soles, frayed and pulled threads throughout, and holes in the vest.

**Estimate:**  
**£2,000 - 4,000**



**950A**  
Production Script m  
**Blade Runner (1982)**

A production script from Ridley Scott's sci-fi classic Blade Runner. Dated "December 22, 1980", this script has a total page count of 140, bound together by a metal binder in the left-sided margin. There is a minor tear on the back cover page, while the rest of the script exhibits minor wear, including markings on a minimal amount of pages. Dimensions: 28.25 cm x 21.75 cm x 1.75 cm (11" x 8.5" x 0.75")

**Estimate:**  
**£1,500 - 3,000**



**951**  
Crew Jacket m  
**Blade Runner (1982)**

A crew jacket from the production of Ridley Scott's sci-fi classic Blade Runner. Custom-made by the Cloth Tattoo company, the back of the jacket features embroidery of "Blade Runner" and the Japanese translation underneath. The bomber jacket is labelled as a size "XL".

**Estimate: £800 - 1,600**





**952**  
Licence Plate †  
**Blade Runner (1982)**

A licence plate from Ridley Scott's sci-fi thriller Blade Runner. Rick Deckard (Harrison Ford) and the residents of a dystopian Los Angeles drove flying "spinner" vehicles throughout the city's crowded airways. This black tin spinner licence plate reads "3A3" in yellow and features a white stencilled barcode. It is intentionally distressed with faux grime and rust and exhibits real rust on its back from age. Dimensions: 20.5 cm x 15.5 cm (8" x 6")

**Estimate: £2,000 - 4,000**



**953**  
Freddie Mercury's (Rami Malek) Screen-matched  
Work Costume †  
**Bohemian Rhapsody (2018)**

Freddie Mercury's (Rami Malek) Screen-matched work costume from Bryan Singer and Dexter Fletcher's 2018 biopic Bohemian Rhapsody. Freddie wore his costume while working as a baggage handler at Heathrow Airport, prior to joining rock band Queen. The lot comprises an orange high-vis vest, a blue boiler suit, a zip-up cardigan and a pair of brown leather boots. The creasing in the vest screen-matches it to the scene. Each item of clothing features a costume label that specifies the character name, performer name and scene number. The boiler suit features additional internal labels that read "EC470" and "ZE488". Labels in the boots read "Ross C". The vest features some intentional dirtying.

**Estimate: £2,000 - 4,000**



**954**  
Freddie Mercury's (Rami Malek) Diagnosis  
Leather Jacket †  
**Bohemian Rhapsody (2018)**

Freddie Mercury's (Rami Malek) diagnosis leather jacket from Bryan Singer's 2018 rock biopic Bohemian Rhapsody. Freddie wore his jacket to his doctor's appointment, where he was diagnosed with AIDS. The jacket is made of brown leather with a cream faux-fur lining. An attached tag reads "EMBARGO Bohemian Rhapsody Character Freddie Mercury Name Rami Malek Scene 140-142 Change 56 brown leather and shearing [sic] jkt Angels #62842". There are some tears in the lining of the pockets, but the garment otherwise remains in very good condition.

**Estimate: £1,000 - 2,000**

**955**  
Freddie Mercury's (Rami Malek) Smile Gig and  
Changing Room Costume †  
**Bohemian Rhapsody (2018)**

Freddie Mercury's (Rami Malek) Smile gig and changing room costume from Bryan Singer's 2018 rock biopic Bohemian Rhapsody. Freddie wore one of his outfits to see the band Smile performing at a local pub, and the other while in a changing room with Mary Austin (Lucy Boynton). This lot comprises a pink-and-burgundy T-shirt; a patterned shirt; a zip-up denim jacket; a belted burgundy velvet jacket; and a pair of white shoes. A number of the items feature labels specifying character, performer and scene number. The shirt has an additional handwritten label that reads, "Freddie Angels hire" and handwriting in the collar that reads "1970 BBC". The shoes have an "Angels" label fixed to the insoles and exhibit some scuffing, but otherwise both costumes remain in excellent condition.

**Estimate: £1,000 - 2,000**



**956**  
Collection of Freddie Mercury's (Rami Malek) Tops †  
**Bohemian Rhapsody (2018)**

A collection of Freddie Mercury's (Rami Malek) tops from Bryan Singer and Dexter Fletcher's 2018 musical biopic Bohemian Rhapsody. Included are two vests and three T-shirts, one short-sleeved patterned shirt, and a patterned robe, worn by Freddie in various scenes throughout the film, including whilst recording music and whilst with Mary Austin (Lucy Boynton). Also included is a delivery note. A number of the items feature labels specifying character, performer, and scene number, and additional internal labels in one of the -shirts and the short-sleeved shirt read "Freddie fitted Angels".

**Estimate: £1,000 - 2,000**



**957**  
Cast-Autographed "Beauty and The Beast" First Draft  
Script and Cast Photo †  
**Boston Legal - Beauty and the Beast (2007)**

A cast-autographed "Beauty and the Beast" first draft script and cast photo from the series Boston Legal. In the Season 4 episode "Beauty and the Beast," Carl Sack (John Larroquette) joined the Boston legal team and assigned a first degree murder case to newly Harvard Law graduate Katie Lloyd (Tara Summers). This lot consists of an 82-page first draft script written by David E. Kelley titled "Beauty And The Beast (Season 4/ Production #4F01) Story # 7072" with clear acetate covers; and a 20.5 cm x 25.5 cm (8" x 10") colour production still. The script features a cast list dated August 31, 2007 and a set list dated August 28, 2007. This script is autographed by Candice Bergen, William Shatner, Taraji P. Henson, John Larroquette, Gary Anthony Williams, Saffron Burrows, Christian Clemenson, and Tara Summers in black ink. The script exhibits minor stains near the brads that bind the script. Dimensions: 21.75 cm x 25.5 cm x 2 cm (8.5" x 11" x 0.75")

**Estimate: £800 - 1,600**

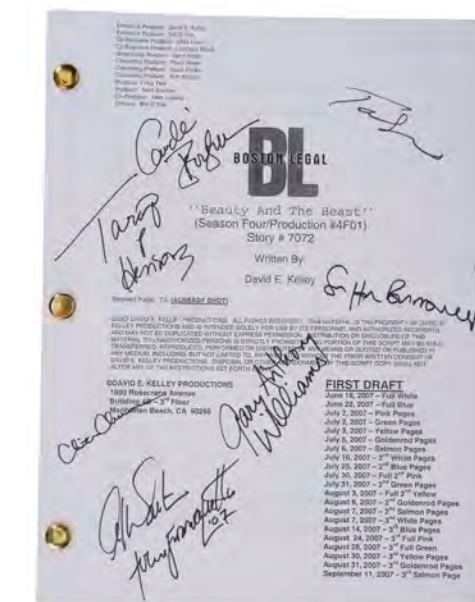

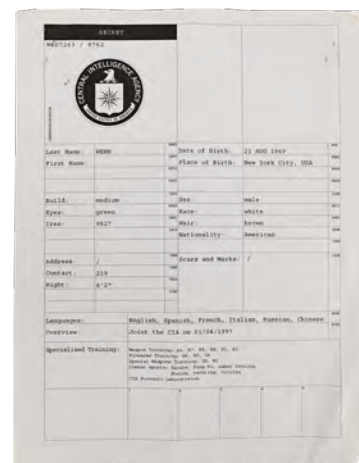
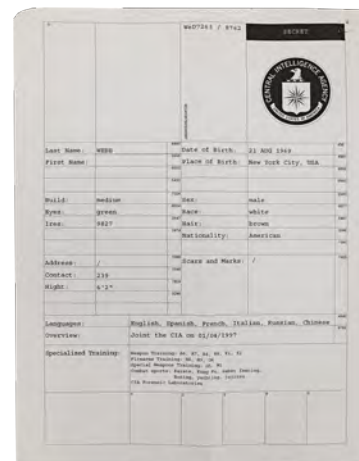

**958**  
Lieutenant William Bligh's (Anthony Hopkins) Jacket and Waistcoat +  
**The Bounty (1984)**

Lieutenant William Bligh's (Anthony Hopkins) jacket and waistcoat from Roger Donaldson's historical drama *The Bounty*. Bligh wore his costume while in command of *The Bounty* and on the island of Tahiti. Both costume pieces feature Bermans & Nathans costume labels with Hopkin's name and both have been intentionally distressed to appear well worn. There are additional stains and markings from production-use and age, most notably some purplish staining all over.

**Estimate: £1,000 - 2,000**

**959**  
Jason Bourne (Matt Damon) CIA Paperwork +  
**The Bourne Ultimatum (2007)**

Jason Bourne (Matt Damon) CIA paperwork from Paul Greengrass' mystery thriller *The Bourne Ultimatum*. Pam Landy (Joan Allen) examined Bourne's CIA paperwork and photograph in her office. The lot includes two paper ID photographs of Bourne and two paper copies of his personal data file. All of the pieces exhibit stains. Dimensions (largest piece): 28 cm x 22 cm (11" x 8.75")

**Estimate: £400 - 800**

**960**  
Mornay's (Alun Armstrong) Kilt +  
**Braveheart (1995)**

Mornay's (Alun Armstrong) kilt from Mel Gibson's historical epic *Braveheart*. Scottish lord Mornay wore his kilt as he fought alongside, and then later betrayed, William Wallace (Mel Gibson). This traditional-style woollen kilt is pleated at the rear with ties to the waist, with a large amount of surplus material to throw over the shoulder to resemble a belted plaid, which was common Highland dress. The costumes for the production were created by the costumiers Angels.

**Estimate: £2,000 - 4,000**

**961**  
Cast-autographed Commercial Poster +  
**The Breakfast Club (1985)**

A commercial poster for John Hughes' coming-of-age comedy *The Breakfast Club*, autographed by the main members of the cast. The actors depicted in the poster's artwork, Emilio Estevez (Andrew Clark), Molly Ringwald (Claire Standish), Ally Sheedy (Allison Reynolds), Anthony Michael Hall (Brian Johnson), and Judd Nelson (John Bender), have signed it with their autographs in blue marker pen. Dimensions: 97 cm x 67.5 cm (38.25" x 26.5") The autographs in this lot have been professionally authenticated by expert Garry King; see notice in the Buyer's Guide.

**Estimate: £500 - 1,000**

**962**  
Walter White's (Bryan Cranston) Black Jacket +  
**Breaking Bad (T.V. Series, 2008-2013)**

Walter White's (Bryan Cranston) black jacket from Vince Gilligan's television series *Breaking Bad*. Walt assumed the name "Heisenberg" to grow his methamphetamine empire through fear, donning his signature black jacket as part of his trademark "Heisenberg" costume throughout the series. Manufactured by London Fog, this golf-style jacket (Size L) has a black polyester outer shell, with a polyester mesh inner liner on the inside, an elastic waistband, snap buttons on the wrist cuffs, two front zip pockets, three interior pockets with self-fastening strip closures, and a front zip closure.

**Estimate: £1,500 - 3,000**

**963**  
Omniguard Costume +  
**Buck Rogers In The 25Th Century - Twiki Is Missing (1979)**

An Omniguard costume from *Buck Rogers in the 25th Century*. In the Season 1 episode "Twiki Is Missing," Captain William "Buck" Rogers' (Gil Gerard) robot friend and assistant Twiki was kidnapped by Kurt Belzak's (John P. Ryan) enforcers to study Twiki's composition. This lot consists of a dark green poly-cotton Dickies jumpsuit marked "40M" with a black mesh collar and black padded cuffs; and a black suede and light green satin trim neck covering featuring a white and blue embroidered patch. This lot exhibits loose threading in the mesh.

**Estimate: £1,000 - 2,000**



**964**  
 Buffy's (Sarah Michelle Gellar) Stunt Stake  $\alpha$   
**Buffy The Vampire Slayer (T.V. Series, 1997-2003)**

Buffy's (Sarah Michelle Gellar) stunt stake from the television series Buffy the Vampire Slayer. Starting in Season 3 and well through Season 4, Buffy and the Scooby Gang used stakes in style such as this as they slayed creatures. Made of foam rubber, this stake features detailed painting to resemble wood. It has a flat pommel and a curved shaft, giving it a furniture-leg appearance. This lot exhibits chipping on the frame and a buildup of grime.  
 Dimensions: (displayed) 31.75 cm x 38.5 cm x 5.75 cm (12.5" x 15.25" x 2.25")

**Estimate: £3,000 - 6,000**



**965**  
 Pair of Crew Tops and Thirteen Behind-the-Scenes Photos  $\mathfrak{M}$   
**Bugsy Malone (1976)**

A pair of crew tops and twelve behind-the-scenes photographs from the production of Alan Parker's family comedy Buggy Malone.

12 of the photographs depict various cast members on set, such as Sheridan Earl Russell (Knuckles) and Martin Lev (Dandy Dan). The 13th photograph shows crew members on set in the club, which was the location of the food fight scene. One crew T-shirt is an adult's size, while the other is a child's, gifted to a child cast member.

The adult crew T-shirt exhibits stains on its front.  
 Dimensions (large photo): 25.75 cm x 20.5 cm (10" x 8")

**Estimate: £400 - 800**

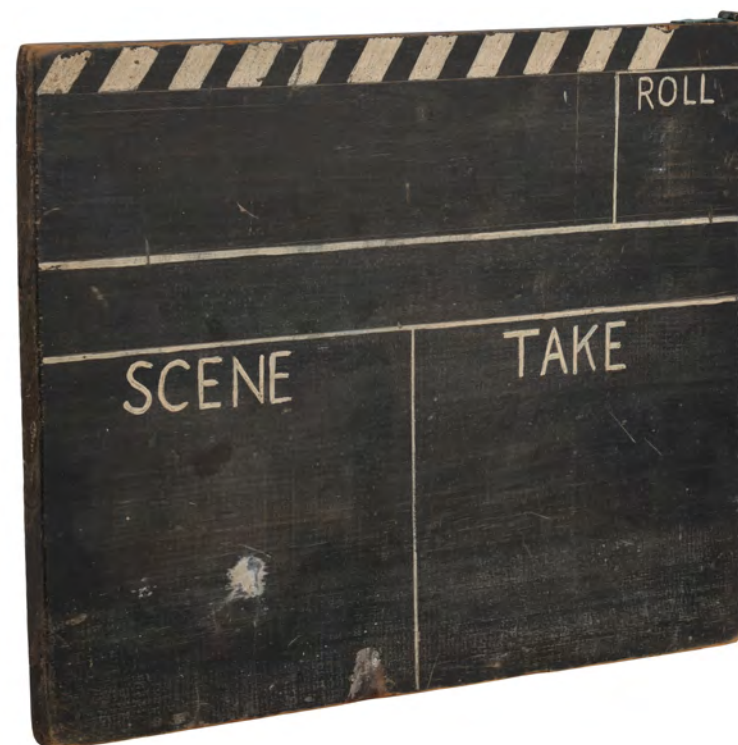

**966**  
 Production-used Clapperboard  $\dagger$   
**Camberwick Green (T.V. Series, 1966)**

A production-used clapperboard from the production of the British children's animation TV series Camberwick Green. This clapperboard is a classic design with its black wooden 'slate' and white lines. It comes with four pieces of production paperwork. The clapperboard does not possess its top sticks.  
 Dimensions: 37.25 cm x 29.5 cm x 1.75 cm (14.75" x 11.5" x 0.75")

**Estimate: £1,500 - 3,000**

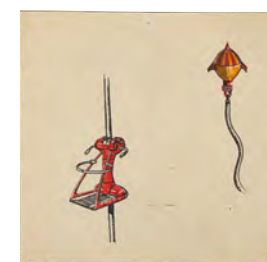
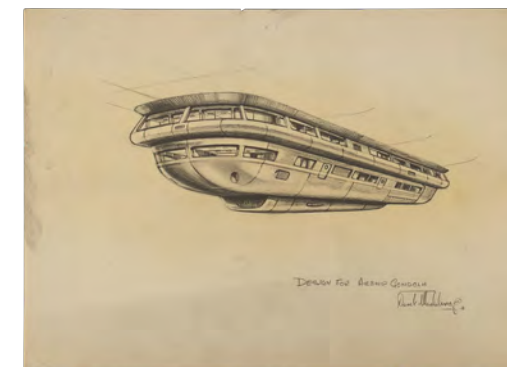

**967**  
 Three Derek Meddings Drawings  $\mathfrak{M}$   
**Captain Scarlet And The Mysterons (T.V. Series, 1967-1968)**

Three illustrations from the production of Gerry and Sylvia Anderson's TV series Captain Scarlet and the Mysterons. The lot includes two hand-drawn pencil sketches and one hand-coloured sketch, all drawn by Derek Meddings, the supervising visual effects director on the series. The pencil sketches are of an airship gondola and a Mysteron detector, and the coloured page features two miscellaneous, unidentified items. The gondola design has "Design for airship gondola" handwritten in pencil beneath it, along with Meddings' signature. The Mysteron detector has been hand-annotated by Meddings. The pages exhibit yellowing from age, as well as minor smudging. Dimensions: 36 cm x 25 cm (14.25" x 10.25") Sold without copyright; see copyright notice in the Buyer's Guide.

**Estimate: £400 - 800**



**968**  
 Casanova's (Heath Ledger) Party Costume  $\dagger \Delta$   
**Casanova (2005)**

Casanova's (Heath Ledger) costume from Lasse Hallström's adventure comedy Casanova. Casanova wore his party costume at the Venetian Carnival, and during his subsequent trial. The costume comprises a coat made of synthetic fabric with quilted layers and an embedded bum pad; a waistcoat made of the same synthetic material with a handwritten "H. Ledger" costume label on its interior; a white linen shirt with "Casanova" handwritten on a costume label; a pair of black trousers made of synthetic fabric with "49" and "5" handwritten in ink on their interior costume label; a pair of long black polyester socks; and a linen neckerchief. The photograph depicts Ledger in character wearing a different costume and features "To Chris best wishes" followed by his autograph. The autographs in this lot have been professionally authenticated by expert Garry King; see notice in the Buyer's Guide.

**Estimate: £4,000 - 8,000**

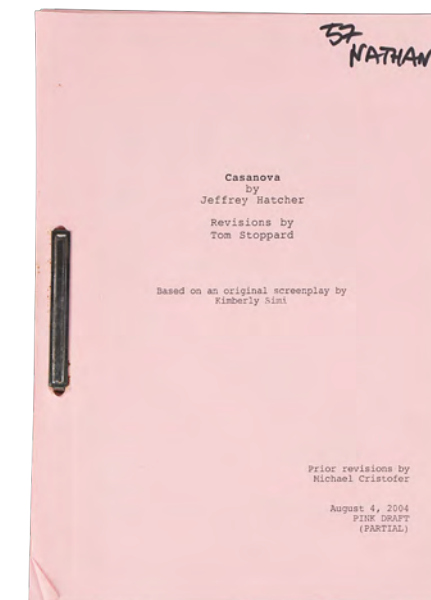

**969**  
 Heath Ledger-autographed Photo and Production Script  $\mathfrak{M}$   
**Casanova (2005)**

An autographed photo of Heath Ledger and a script from the production of Lasse Hallström's historical romance Casanova. This lot comprises a photograph of Heath Ledger in character as Giacomo Casanova, autographed by the actor in black ink, and a production script. The script is titled "Casanova" and dated "August 4 2004", and is credited to Jeffrey Hatcher, with revisions made by Tom Stoppard. At 115 pages long, it is a partial draft, which features "57 Nathan" written in black ink at the top right corner of the front cover. Dimensions: 30 x 22 x 2 (11.75" x 8.75" x 0.75") The autographs in this lot have been professionally authenticated by expert Garry King; see notice in the Buyer's Guide.

**Estimate: £1,000 - 2,000**

**970**  
 Frank Abagnale Jr's  
 (Leonardo DiCaprio) "Frank Taylor"  
 Chequebook  $\Omega$   
**Catch Me If You Can (2002)**

Frank Abagnale Jr's (Leonardo DiCaprio) "Frank Taylor" chequebook from Steven Spielberg's Catch Me If You Can. Abagnale used "Taylor" as an alias while he posed as an airline pilot and amassed money through forgery. This chequebook contains a black cover, a check register, and a full book of checks with "Frank Taylor" as the name. The register features handwritten "Frank Taylor" in blue ink, as well as an account number "2158-250" and a withdrawal of "300.00" dated 1964. The checks also feature the logo and address of The Chase Manhattan Bank. This lot exhibits a buildup of grime, a bent metal clip, and minor ripping on the check register. Dimensions: 7.75 cm x 18 cm x 1.5 cm (3" x 7" x 0.5")

**Estimate: £2,000 - 4,000**



**971**  
 Frank Abagnale, Jr.'s  
 (Leonardo DiCaprio) Stack of Blank  
 "Frank Roberts" Pan Am Checks  $\Omega$   
**Catch Me If You Can (2002)**

Frank Abagnale, Jr.'s (Leonardo DiCaprio) stack of blank "Frank Roberts" Pan Am checks from Steven Spielberg's Catch Me If You Can. Carl Hanratty (Tom Hanks) traced Abagnale by following a trail of checks he cashed under the name "Frank Roberts." This lot consists of a bound stack of matching blank paper checks, each with perforated edges, the Chase Manhattan Bank logo printed in their bottom left corners, and the Pan Am logo printed above and watermarked throughout each. The checks in the stack exhibit discoloration, creasing, and minor tears from production. Dimensions: (each) 9 cm x 21.5 cm x 5.75 cm (3.5" x 8.5" x 2.25")

**Estimate: £1,500 - 3,000**



**972**  
 Roman Soldier Costume m  
**Centurion (2010)**

A Roman soldier costume from Neil Marshall's war drama Centurion. Roman soldiers wore their armour throughout the film as they battled the Picts north of Hadrian's Wall. The costume includes a helmet, 'lorica segmentata' body armour, and a pair of vambraces, all featuring leather fastenings and made from segments of moulded durable vinyl finished in metallic paints to give the look of worn, field-used steel. Its remaining components are a pair of leather boots, a rubber belt finished to look like leather and brass, and cotten undergarments.

**Estimate: £2,000 - 4,000**



**973**  
 Charlie Chaplin's  
 (Robert Downey Jr.) Cane m  
**Chaplin (1992)**

Charlie Chaplin's (Robert Downey Jr.) cane from Richard Attenborough's biopic Chaplin. Chaplin carried his cane in multiple scenes while playing the Tramp, most notably the one in which he impressed Hollywood comedy producer Mack Sennett (Dan Aykroyd). Chaplin created the iconic look of the Tramp after seizing several items from a communal male dressing room. Crafted from resin, the thin-ridged cane features a cast-in texture and is hand-painted in various shades of yellow and brown to resemble bamboo. The top end of the cane is curved to form a handle, while its tip features a brass-coloured metal cap. Dimensions: 87 cm x 10.5 cm x 2 cm (34.25" x 4.25" x 0.75")

**Estimate: £3,000 - 6,000**

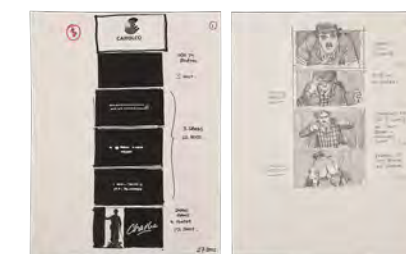

**974**  
 Martin Asbury Hand-drawn  
 Production Storyboards m  
**Chaplin (1992)**

A collection of Martin Asbury hand-drawn storyboards from Richard Attenborough's biographical comedy-drama film Chaplin. Asbury has storyboarded many high-profile films such as Labyrinth, Interview with the Vampire, Alien 3 and two of the Harry Potter features. The lot comprises 108 pages depicting various scenes from the film. The storyboards are rendered onto paper and cardstock in mixed media and feature handwritten annotations. The shots differ slightly from those in the final cut. A few of the storyboards are printed, rather than hand-drawn originals. The pages exhibit some markings and minor discolouration. Dimensions: 30 cm x 21.5 cm x 4.5 (11.75" x 8.5" x 1.77")

**Estimate: £2,000 - 4,000**

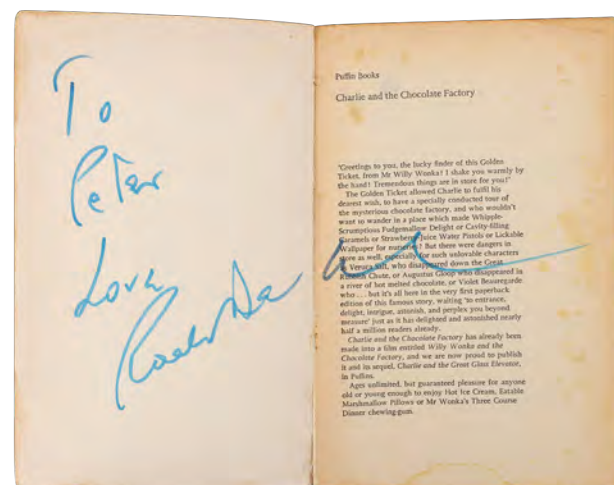
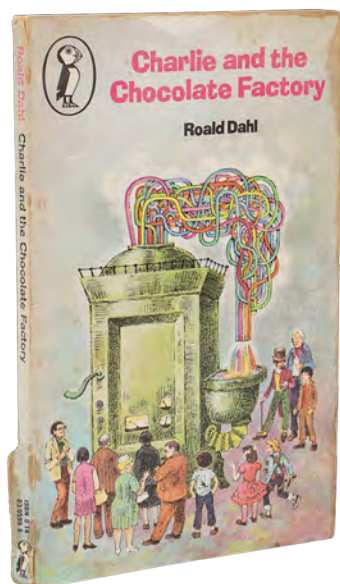

**975**  
Roald Dahl-autographed Charlie and the Chocolate Factory Book m  
**Charlie And The Chocolate Factory (1964)**

A Charlie and the Chocolate Factory book autographed by the author himself, Roald Dahl. This is a Penguin Books edition with cover art illustrated by Faith Jaques. On one of the book's first pages before the story begins, the author has handwritten "To Peter, love Roald Dahl" in blue marker. His name is rendered as his autograph. The bottom of the book's spine exhibits peeling. Dimensions: 20 cm x 13 cm x 2 cm (7.75" x 5" x 0.75") The autograph in this lot has been professionally authenticated by expert Garry King; see notice in the Buyer's Guide.

**Estimate: £600 - 1,200**



**976**  
Two Wonka Bars, Assorted Wonka Branded Packaging and Crew Gift Key Chain †Δ  
**Charlie And The Chocolate Factory (2005)**

A pair of Wonka bars, assorted Wonka branded packaging and a crew gift key chain from Tim Burton's family comedy Charlie and The Chocolate Factory. Wonka bars appeared in various locations during the hunt for the five Golden Tickets, and key chains were gifted to crew members by Johnny Depp. The plastic Wonka bars come packaged in foil and an orange wrapper featuring a printed seal and nutritional information. The assorted Wonka-branded packaging includes a cardboard box, thirteen unused Wonka bar wrappers and a paper bag. Completing the lot is a ball-link chain crew gift presented in a thin gift box. The packaging exhibits creasing; there is notable wear on the box exterior, and the foil on one bar is ripped. Dimensions (box): 19 cm x 17.5 cm x 9 cm (7.5" x 6.75" x 3.5"); (bar): 9.5 cm x 19 cm x 1 cm (3.75" x 7.5" x 0.25")

**Estimate: £1,500 - 3,000**



**977**  
Augustus Gloop (Philip Wiegratz) Bitten Chocolate Bar and Pair of Golden Tickets m  
**Charlie And The Chocolate Factory (2005)**

A chocolate bar and pair of golden tickets bitten by Augustus Gloop (Philip Wiegratz) from Tim Burton's family fantasy film Charlie and the Chocolate Factory. Augustus Gloop was the first child to find a golden ticket hidden in his chocolate bar, but not before biting into both the bar and the ticket.

The bar is made of resin, while the branded packaging and golden tickets are paper. A section has been removed from both the golden tickets and the bar to make them appear as if they've been bitten into.

Also included in the lot is a picture of the character autographed in black marker pen by Wiegratz. The wording on the bar's branded packaging is in English, despite it appearing in German on the bar seen on screen. Dimensions (bar): 20.5 cm x 9 cm x 1.5 cm (8" x 3.5" x 0.5")

**Estimate: £2,000 - 4,000**

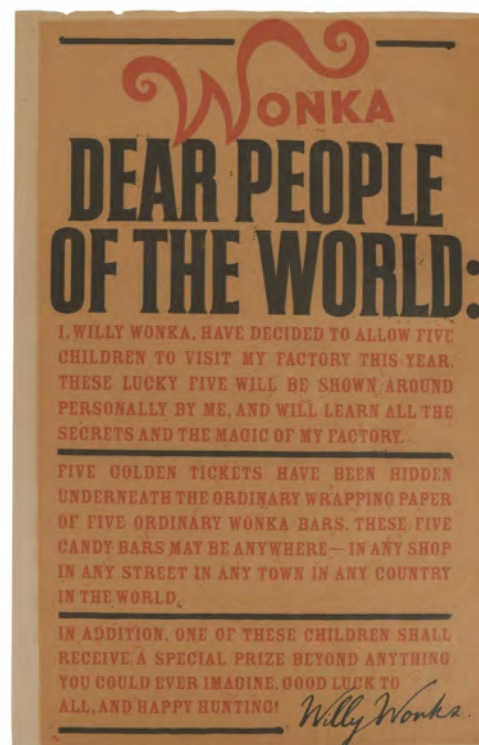

**978**  
Willy Wonka Golden Ticket Announcement Poster m  
**Charlie And The Chocolate Factory (2005)**

A Willy Wonka Golden Ticket announcement poster from Tim Burton's family comedy Charlie and The Chocolate Factory. Posters were put up when celebrated chocolatier Willy Wonka (Johnny Depp) announced a global contest in which five lucky children would win a Golden Ticket to a tour of his mysterious factory. Printed on thin paper, the poster declares the rules of the contest and is presented in a custom-made frame with a themed cutout border. Dimensions: 69 cm x 40.75 cm x 2 cm (27.25" x 16" x 0.75")

**Estimate: £800 - 1,600**

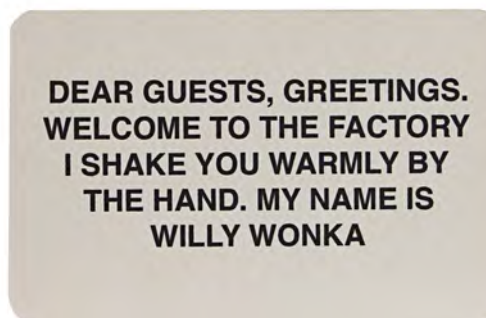

**979**  
Willy Wonka (Johnny Depp) Prompt Card m  
**Charlie And The Chocolate Factory (2005)**

A Willy Wonka (Johnny Depp) prompt card from Tim Burton's family comedy Charlie and the Chocolate Factory. At the gates to his factory, Wonka read from a prompt card when greeting those lucky enough to find a golden ticket. The card has Wonka's dialogue on one side and his logo on the other. It is presented in a custom-made frame with a themed cutout border that features a still from the film. Dimensions: 58 cm x 36 cm x 8 cm (22.75" x 14.25" x 3.25")

**Estimate: £1,000 - 2,000**



**980**  
Hero Animatronic Oompa Loompa (Deep Roy) m  
**Charlie And The Chocolate Factory (2005)**

A hero animatronic Oompa Loompa (Deep Roy) from Tim Burton's Charlie and The Chocolate Factory. Oompa Loompas worked in Willy Wonka's (Johnny Depp) fantastical chocolate factory. This hero animatronic Oompa Loompa is one of 54 created for the miniature version of Wonka's Candy Boat, all featuring a built-in mechanism that allowed them to be drawn forward by the vessel's motion, creating the illusion they were rowing it. This animatronic figure's resin head is hand-painted to resemble Roy, who played all the Oompa Loompas. The body is made of foam over a metal armature with rubber hands. The faux hair on top of the head remains firmly swept back, and a now-inactive electrical wire is found below the neck. The animatronic is dressed in a zipper-backed vented rubber jumpsuit (logo removed after filming), rubber shoes, and a black-and-white striped cotton undergarment. This figure is presented on a black wood and metal stand, with a spare pair of hands and a production-made but unused metal-and-rubber headset. Dimensions: 40.25 cm x 22.25 cm x 68 cm (15.75" x 8.75" x 26.75") Contains electronics; see electronics notice in the Buyer's Guide.

**Estimate: £3,000 - 6,000**

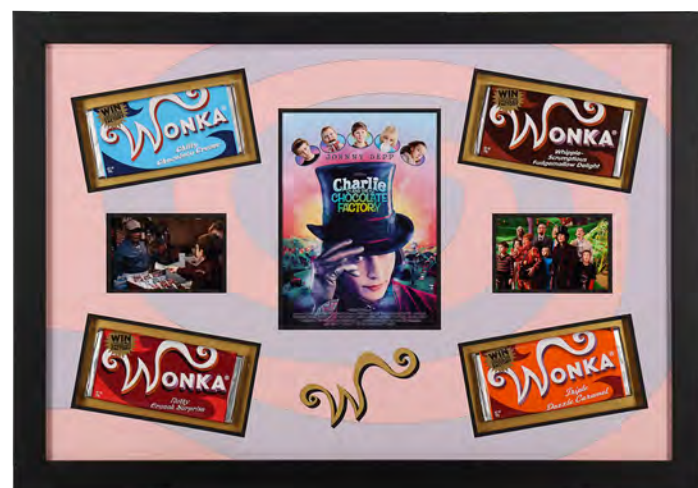

**981**  
Set of Four Wonka Bars in Display m  
**Charlie And The Chocolate Factory (2005)**

A set of four Wonka bars from Tim Burton's fantasy adventure Charlie and the Chocolate Factory. Five lucky children were given a tour of Willy Wonka's (Johnny Depp) factory after they won a global competition to find elusive golden golden tickets hidden in Wonka bar wrappers. The four Wonka bars are covered in silver foil and colourful wrappers, which feature printed seals and nutritional information. Each bar inside the packaging is made of injection moulded brown plastic. The bars are displayed in a wooden frame beside stills from the movie and a print of the commercial poster. Dimensions: 86 cm x 60 cm x 5 cm (33.75" x 23.5" x 2")

**Estimate: £1,000 - 2,000**

**982**  
Autographed Willy Wonka (Johnny Depp) Painting m  
**Charlie And The Chocolate Factory (2005)**

An autographed Willy Wonka (Johnny Depp) painting from the promotion of Tim Burton's Charlie and the Chocolate Factory. This hand-painted image shows Willy Wonka in his costume wearing protective glasses during the scene when Mike Teavee (Jordan Fry) is shrunk. "Good Morning Starshine. . . The Earth Says. . . Hello!!! - W.W." is handwritten in the top right corner, above Depp's autograph. The canvas is stretched over a wood frame. Dimensions: 92 cm x 92 cm x 4 cm (36.25" x 36.25" x 1.5") The autographs in this lot have been professionally authenticated by expert Garry King; see notice in the Buyer's Guide.

**Estimate: £2,000 - 4,000**

**983**  
Cast-Autographed Script m  
**Cheers - Cheers: The Motion Picture (1987)**

A cast-autographed script from the iconic TV sitcom Cheers. Cheers ran for a total of 275 episodes across 11 years. This script is for the Season 5 episode "Cheers: The Motion Picture" and has been autographed and inscribed by seven members of the principle cast: Ted Danson, Shelley Long, John Ratzenberger, George Wendt, Rhea Perlman, Woody Harrelson and Kelsey Grammer. Each actor has written a short message to "Ed". Dimensions: 28 cm x 22 cm x 1 cm (11" x 8.75" x 0.5") The autographs in this lot have been professionally authenticated by expert Garry King; see notice in the Buyer's Guide.

**Estimate: £1,000 - 2,000**

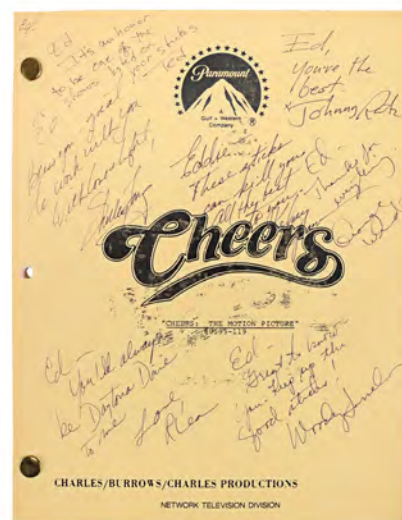

**984**  
Jasper Palmer's (Michael Caine) Screen-matched Cardigan and Costume, Theo Faron's (Clive Owen) Screen-matched Sweatshirt and Costume, Kee's (Clare-Hope Ashitey) Costume and a Prop Baby m  
**Children Of Men (2006)**

Jasper Palmer's (Michael Caine) screen-matched cardigan and costume, Theo Faron's (Clive Owen) screen-matched sweatshirt and costume, Kee's (Clare-Hope Ashitey) costume and a prop baby from Alfonso Cuarón's Children of Men. Theo and Kee wore their costumes as they fled after Kee gave birth to the first human baby in nearly two decades. Jasper wore his costume during Theo's visit. The cardigan's knitted patterns match it to the scene where Palmer says farewell to Theo and his allies before he is murdered. Distressing on the embroidered text on Theo's sweatshirt can be matched to the scene on the row boat, when he revealed he had been shot. Jasper's costume comprises a checked shirt; an embroidered waistcoat; a size "XL" patterned woollen cardigan; a pair of size "38W 33L" jumbo cords; a pair of lace-up shoes; a Celtic-style cross on a leather cord; and three beaded bracelets. Theo's intentionally-distressed costume comprises a size "L" corduroy shirt; a size "L" London Olympics 2012 jumper; a long coat; a pair of size "W34 L34" trousers; and a pair of size "11" trainers labelled "Theo". Kee's costume comprises a dress; a hooded top; a cape; a pair of Doc Marten boots; a pair of leg warmers; and a pregnancy body suit with a "post birth bump" label. The dress and hoodie feature faux blood stains. This poncho-wrapped prop baby, used in place of a real infant performer in certain scenes, has rubber skin and a foam interior. Dimensions (prop baby): 43 cm x 17 cm x 24.5 cm (17" x 6.75" x 9.75")

**Estimate: £3,000 - 6,000**

**985**  
Martin Asbury Hand-drawn Production Storyboards m  
**Children Of Men (2006)**

A collection of Martin Asbury hand-drawn storyboards from Alfonso Cuarón's dystopian action thriller film Children of Men. Asbury has storyboarded many high-profile films such as 'Labyrinth', 'Interview with the Vampire', 'Alien 3' and the two final instalments of the 'Harry Potter' series. The lot comprises 46 pages depicting various scenes from the film. The storyboards are rendered onto paper and cardstock in mixed media and feature handwritten annotations. The shots differ slightly from those in the final cut. Some of the storyboards are graphic in nature. The pages exhibit some markings and minor discolouration. Dimensions: 30 cm x 21.5 cm x 3 cm (11.75" x 8.5" x 1.25")

**Estimate: £2,000 - 4,000**

**986**  
Riddick's (Vin Diesel) Necromonger Knife and Mercenary Double Barrel Shotgun m  
**The Chronicles Of Riddick (2004)**

Riddick's (Vin Diesel) Necromonger knife and a mercenary double barrel shotgun from David Twohy's action sci-fi The Chronicles of Riddick. Riddick stabbed Necromonger soldiers with their knives, while Mercs under the crooked bounty hunter Toombs (Nick Chinlund) wielded "gun-chuck" double barrel shotguns on the planet Crematoria. The shotgun is constructed from aluminium with resin detailing. The two barrels can be detached and easily reattached by slotting in together. There is a counter switch and reader on the side of each barrel. Dimensions (shotgun with chain laid out): 78.5 cm x 11 cm x 5 cm (31" x 4.25" x 2") Edged, bladed or blunt object; see notice on Blades in the Buyer's Guide.

**Estimate: £1,500 - 3,000**







**987**  
Joppa Black Guardsman Helmet +  
**Clash Of The Titans (1981)**

A Joppa guardsman helmet from Desmond Davis' fantasy epic Clash of the Titans. The city guards wore their helmets while patrolling Joppa, the home of Queen Cassiopeia (Siân Phillips) and Princess Andromeda (Judi Bowker). The helmet is made from fiberglass painted black to look like metal, while the interior is lined with foam for the wearer's comfort during production. The front of the helmet's curved top edge has chipped to reveal the resin underneath. Dimensions: 37 cm x 22 cm x 32 cm (14.5" x 8.75" x 12.5")

**Estimate: £800 - 1,600**



**988**  
Perseus' (Sam Worthington)  
Stunt Sword m  
**Clash Of The Titans (2010)**

Perseus' (Sam Worthington) stunt sword from Louis Leterrier's fantasy-adventure remake Clash of the Titans. Perseus used his sword on his adventures through ancient Greece, ultimately losing it in his battle with Calibos (Jason Flemyng). Made of hard rubber, the sword handle is marked with intricate swirling wave patterning running from the horseshoe guard to the tip, with the design replicated on both sides. Conical protrusions come out of the guard with rings around the grip. The weapon has been finished in faux-bronze paint with green paint applied in the recesses to mimic the appearance of verdigris. Dimensions: 72 cm x 8 cm x 6 cm (28.5" x 3.25" x 2.5") Edged, bladed or blunt object; see notice on Blades in the Buyer's Guide.

**Estimate: £2,000 - 4,000**



**989**  
Perseus' (Sam Worthington)  
Sword of the Gods m  
**Clash Of The Titans (2010)**

Perseus' (Sam Worthington) Sword of the Gods from Louis Leterrier's fantasy-adventure remake Clash of the Titans. Imbued with the divine power of Olympus, this weapon's magical blade emerged whenever Perseus went into battle. This dense rubber version of the broadsword was created for fight sequences where the blade was already extended. It is hand-painted silver and engraved at the base of the blade with images of the Gods running alongside Apollo's chariot and down the handle with criss-cross patterns. Dimensions: 120 cm x 7 cm x 3 cm (47.25" x 2.75" x 1.25") Edged, bladed or blunt object; see notice on Blades in the Buyer's Guide.

Payment plans are not available for this lot. Please contact us for further information.

**Estimate: £3,000 - 6,000**



**990**  
Alex DeLarge's (Malcolm McDowell) Pillow Case and  
Duvet Cover and Script Pages m  
**A Clockwork Orange (1971)**

Alex DeLarge's (Malcolm McDowell) Pillow Case and Duvet Cover pillowcases and a duvet cover and script pages from the production of Stanley Kubrick's dystopian crime film A Clockwork Orange. Alex kept blue bed covers on his bed, which is later let out by his parents whilst he is being rehabilitated. Seven script pages are included, printed on yellow paper and dated "13 September 1970". The pages are all revision pages, and feature "B Welch" written in the top corner. The pillowcases exhibit minor damage, including a few small holes, but otherwise all the items remain in very good condition. These were purchased by a crew member at the after wrap prop sale. Dimensions: 42 cm x 29 cm x 5 cm (16.5" x 11.5" x 2")

**Estimate: £600 - 1,200**

**992**  
Douglas Trumbull Collection: Set of Three Production  
Paper Slates with Photo o  
**Close Encounters Of The Third Kind (1977)**

A set of three production paper slates from the special effects photography of Steven Spielberg's Close Encounters of the Third Kind. Smaller slates made of paper were used during the filming of special effects sequences using model miniatures. These slates from the collection of special photographic effects artist Douglas Trumbull are printed in black-and-white on white three-hole-punched paper and feature the film's title, the Paramount logo, and spaces for shot and camera information, which have been filled in with blue marker. These are dated "6-3-76" and "6-4-76" and the shots are described as "Camera Med #1," "Camera High #2," and "Low #3." Also included is a three-hole-punched colour-printed photograph of the model miniature set with one such paper slate taped to it. They exhibit some minor creasing and bending from use and age. Dimensions: (each) 21.75 cm x 28 cm (8.5" x 11")

**Estimate: £1,000 - 2,000**



**991**  
Production-made Alien Head tΔ  
**Close Encounters Of The Third Kind (1977)**

A production-made alien head from Steven Spielberg's sci-fi drama Close Encounters of the Third Kind. Small alien creatures revealed themselves to humanity during the film's climax at Devils Tower. The creature's head is made of durable slip latex and painted a grey-green colour. It has painted blue eyes and a hole in the mouth to allow the child performer wearing the costume to breathe. The head is currently filled with padding to maintain its shape and it has a small tear at the back of the neck. Dimensions: 30 cm x 24 cm x 25 cm (11.75" x 9.5" x 9.75")

**Estimate: £2,000 - 4,000**

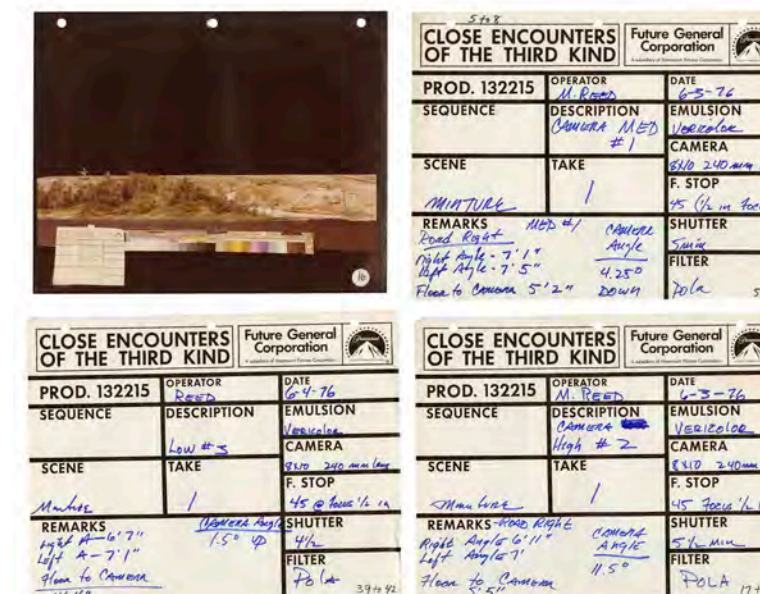

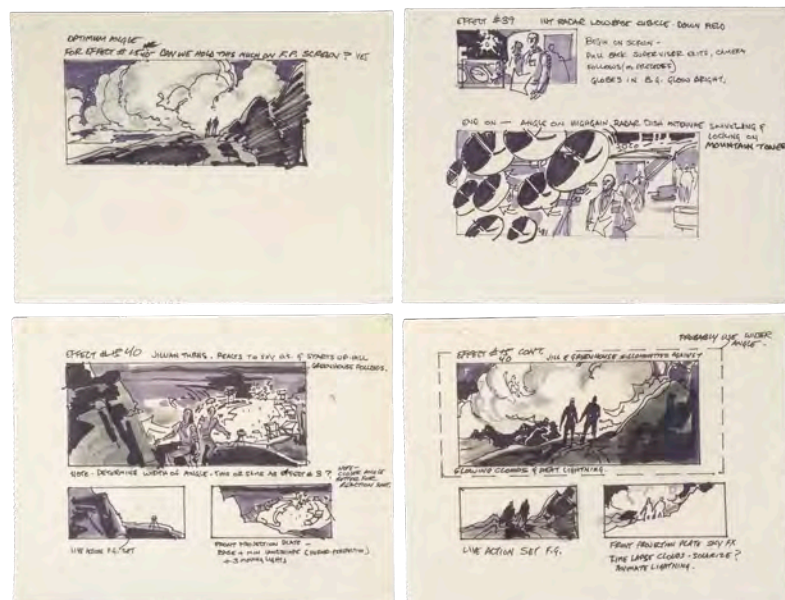

**993**  
Douglas Trumbull Collection: Set of Four Hand-drawn  
George Jenson Devil's Tower FX Storyboards  $\Omega$   
**Close Encounters Of The Third Kind (1977)**

Four hand-drawn special effects storyboards hand-drawn by production illustrator George Jenson for the production of Steven Spielberg's Close Encounters of the Third Kind. In the film, Claude Lacombe (Francois Truffaut) awaited the Mothership as Roy Neary (Richard Dreyfuss) and Jillian Guiler (Melinda Dillon) scaled Devil's Tower. This set comes from the collection of special photographic effects artist Douglas Trumbull. Created by Jenson to coordinate which VFX were needed in the landing sequence, it consists of four sheets of storyboards hand-rendered and numbered "#39," "#1540" and "#1540 Cont" in black ink and marker on illustration paper with handwritten annotations throughout. The sheets are hand-marked "M14," "M15," "M16," and "M17" in graphite. They exhibit rough edges from where the pages were torn out of a spiral-bound drawing pad, pinholes in the corners, minor discolouration, and rough perforated edges. Dimensions: (each) 23 cm x 30 cm (9" x 11.75") Sold without copyright; see copyright notice in the Buyer's Guide.

**Estimate: £800 - 1,600**



48.5 cm (19")

**994**  
Hand-Painted Ralph McQuarrie Deep  
Space Production Illustration  $\Omega$   
**Cocoon (1985)**

A hand-painted Ralph McQuarrie deep space production illustration from Ron Howard's Cocoon. A group of elderly trespassers swam in a pool containing alien cocoons and suddenly felt younger. Created by film conceptual artist Ralph McQuarrie, this image of deep space with solar clouds and an illuminating light is rendered in mixed media on an illustration board. The board is covered with a paper sleeve featuring a doodle rendered in graphite. This painting exhibits discolouration around the edges, tape residue on the back of the board, and the cover is separated from the painting. Dimensions: 30.5 cm x 48.5 cm x 0.75 cm (12" x 19" x 0.25") Sold without copyright; see notice in the Buyer's Guide.

**Estimate: £2,000 - 4,000**

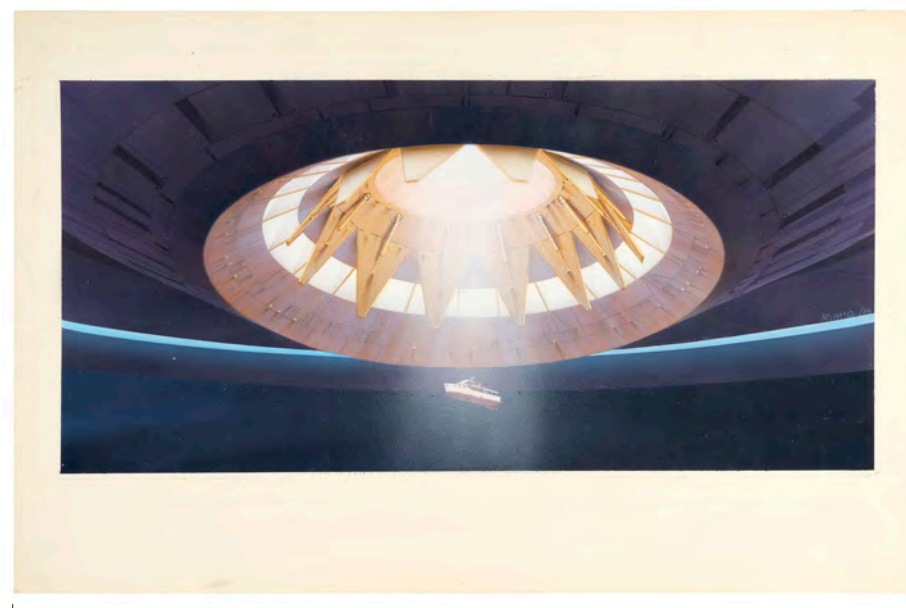

40.75 cm (16")

**995**  
Hand-Painted Ralph McQuarrie Boat  
Pulled Into Ship Production Illustration  $\Omega$   
**Cocoon (1985)**

A hand-painted Ralph McQuarrie boat pulled into a ship production illustration from Ron Howard's Cocoon. A group of elderly trespassers swam in a pool containing alien cocoons, and suddenly found themselves feeling younger. Created by film conceptual artist Ralph McQuarrie, this image of a boat being beamed by an alien ship is rendered in mixed media on an illustration board. The illustration is signed "R.McQ./84" along the space ship's edge. This painting exhibits discolouration around the edges and minor tape residue on the backing. Dimensions: 40.75 cm x 25.5 cm x 0.75 cm (16" x 10" x 0.25) Sold without copyright; see notice in the Buyer's Guide.

**Estimate: £2,000 - 4,000**

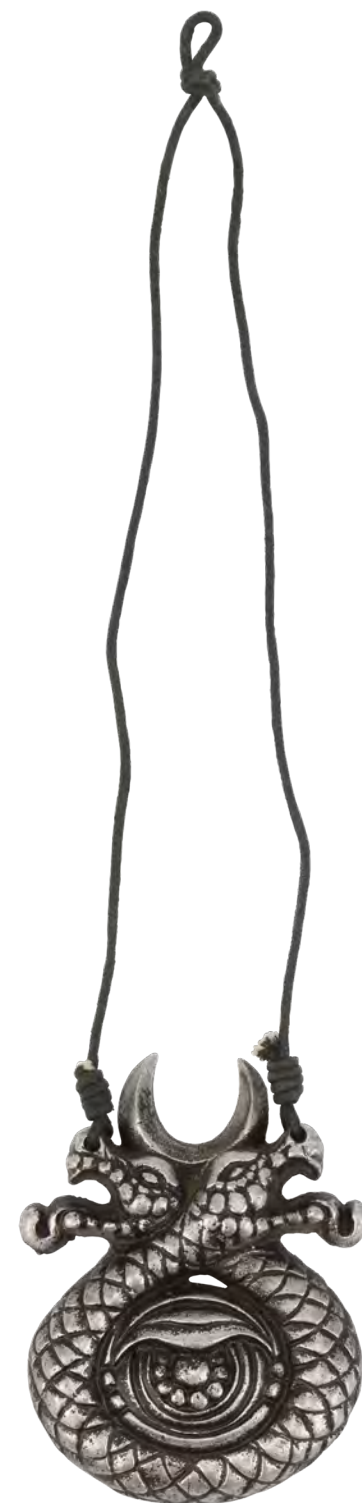

**996**  
Cult of Set Amulet  $\dagger\Delta$   
**Conan The Barbarian (1982)**

A Cult of Set amulet from John Milius' fantasy adventure Conan the Barbarian. Members of the Cult of Set wore their amulets with their costumes throughout the movie as they maintained allegiance to their ruthless leader Thulsa Doom (James Earl Jones). This silver-colour metal amulet consists of two snakes looped around a sinister, all-seeing eye with a curved horn situated at the top and a black string necklace. Dimensions (with necklace laid out): 42.5 cm x 9.5 cm x 2.5 cm (16.75" x 3.75" x 1")

**Estimate: £3,000 - 6,000**



**997**  
Albion Atlantean Sword Replica  $\dagger\Delta$   
**Conan The Barbarian (1982)**

An Albion Atlantean sword replica, produced from the original moulds used during the making of John Milius' action-adventure film Conan the Barbarian. The Atlantean sword was discovered by Conan (Arnold Schwarzenegger) in an ancient tomb and became the signature weapon of the Cimmerian warrior, used throughout the film as he battled against the Cult of Set and Thulsa Doom (James Earl Jones). This heavy metal sword features a cast pommel and cross guard decorated with skulls, creatures and Atlantis-influenced motifs, while the grip is finished with wrapped brown twine. Etched to the side of the guard is the official trademark "©Conan Properties Inc, 2003". The weapon's point remains sharp. The sword is accompanied by a certificate of authenticity from Albion, which indicates that it is a 20th-anniversary issue "461/1000" and was made under the supervision of the original props sword maker, Jody Samson. Dimensions: 99 cm x 17.75 cm x 4 cm (39" x 7" x 1.5") Please note: Due to UK legislation, anyone wishing to buy this piece must be 18 years or over; see restricted ownership notice in the Buyer's Guide.

**Estimate: £3,000 - 6,000**



**999**  
**Hand-Drawn Ron Cobb Crom and Wheel of Pain Concept Artworks**  $\Omega$   
**Conan The Barbarian (1982)**

Three Crom and Wheel of Pain concept artworks hand-drawn by production designer Ron Cobb for John Milius' fantasy adventure Conan the Barbarian. Conan (Arnold Schwarzenegger) prayed to his god, Crom, after Thulsa Doom (James Earl Jones) forced him to push the Wheel of Pain. This set consists of two pages of concept drawings for the Sign of Crom rendered in mixed media and one sheet of lined paper depicting various versions of the Wheel of Pain labelled "SID" and "Keven Haywood." They exhibit fold lines and finger marks throughout. Dimensions: (each) 21.75 cm x 28 cm (8.5" x 11") Sold without copyright; see copyright notice in the Buyer's Guide.

**Estimate: £1,000 - 2,000**

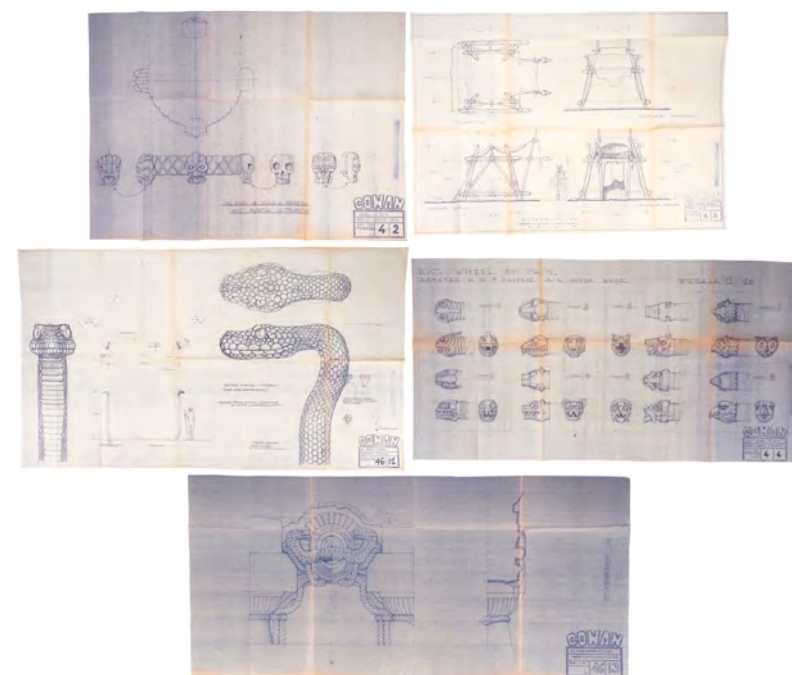

**1000**  
**Set of Five Printed Wheel of Pain and Giant Snake Chamber Blueprints**  $\Omega$   
**Conan The Barbarian (1982)**

Five printed Wheel of Pain and giant snake chamber blueprints from the production of John Milius' Conan the Barbarian. After being released from slavery pushing the Wheel of Pain, Conan (Arnold Schwarzenegger) slayed a giant snake overseeing an occult orgy in seeking vengeance against Thulsa Doom (James Earl Jones). These five blueprints were created by and distributed amongst the film's art and production design teams. Three depict ancient South American-style skull and animal design motifs for the Wheel of Pain; two depict the giant snake and the orgy chamber's snake-themed decor. Each is printed with Spanish and Italian annotations on drafting paper branded "Conan" and features the Dino De Laurentiis Corporation copyright alongside that blueprint's number and title. Two blueprints are initialed by art directors Benjamin Fernandez and Pier Luigi Basile; the others are dated "80" and "2 Septiembre" and initialed by artist "JM." They exhibit fold lines, creasing, and discoloration from age. Dimensions: (largest) 106.75 cm x 86.5 cm (42" x 34") Sold without copyright; see copyright notice in the Buyer's Guide.

**Estimate: £800 - 1,600**



**1001**  
**John Constantine's (Keanu Reeves) Holy Shotgun Shell and Cigarette Packet**  $\Omega$   
**Constantine (2005)**

John Constantine's (Keanu Reeves) holy shotgun shell and cigarette pack from Francis Lawrence's superhero horror film Constantine. Exorcist Constantine hunted demons on Earth and used a Holy Shotgun as his primary weapon. He was also a heavy smoker (contributing to his lung cancer) and his favourite brand were Chang Jiang. The bullet is made of resin and finished in faux gold. The cigarette packet is unopened and both are held in a custom-made framed display, alongside Latin phrases and stills from the film. Dimensions (cigarette pack): 2 cm x 5 cm x 9 cm (1" x 2" x 3.5")

**Estimate: £2,000 - 4,000**

**1002**  
**Stop Motion The Cat Mouth with Mouse**  $\Omega$   
**Coraline (2009)**

A stop motion The Cat mouth with a mouse from Henry Selick's animated fantasy horror Coraline. The Cat (voiced by Keith David) was one of Coraline's (voiced by Dakota Fanning) companions in the other world. The stop motion models for the film were created by the animation studio Laika. This lot features the mouth of The Cat holding one of the performing circus mice in his jaws. The mouth is mounted to a custom-made display below an image of the scene it was made for. Dimensions (display): 8 cm x 8.5 cm x 12 cm (3.25" x 3.25" x 4.75")

**Estimate: £500 - 1,000**



**1003**  
**Screen-matched Land of the Dead Lamps**  $\Omega$   
**Corpse Bride (2005)**

A pair of screen-matched Land of the Dead lamps from Tim Burton's stop-motion musical Corpse Bride. These lights were seen as Victor and Emily wandered through the Land of the Dead and they match through their intentional distress. They are made of brass and painted to look like wrought iron. The larger light retains the fixing where it was attached to the set. The lights have some paintwear, one has a small hole in the side and one panel of the larger light is loose. Dimensions (larger light): 20 cm x 10 cm x 26 cm (8" x 4" x 10.25") Contains electronics; see electronics notice in the Buyer's Guide.

**Estimate: £400 - 800**



**1004**  
**Puppet Heads, Model Crows and Model Information Folder**  $\Omega$   
**Corpse Bride (2005)**

Puppet heads, crows, and a folder of all model details from the production of Tim Burton and Mike Johnson's animated musical fantasy film Corpse Bride. Included in the lot are Victor's head, William Van Dort's head, and Mrs Plum's head, as well as four crows, two wings, a beak and a folder listing details of all the models used in the film. Victor's head is made of resin, William's of foam latex, and Mrs Plum's of silicone. The crows are foam latex layered over a metal armature, and each is modelled into a different position, two flying and two perching. The folder lists all of the film's characters, the components included in their models, what each model piece is made of and the Pantone colour reference for them. William's head and Mrs Plum's head differ slightly from their final versions seen in the film. The foam latex the crows are made of is flaking in places, Victor's head exhibits some paint damage, and some of the crows are missing their feet and/or their tails. Dimensions: 32 cm x 25 cm x 10 cm (12.75" x 10" x 4")

**Estimate: £2,500 - 5,000**





**1005**  
Adonis Creed's Stunt Boxing Shorts and Shoes  
**Creed II (2018)**

Adonis Creed's stunt boxing shorts and shoes from Steven Caple Jr.'s *Creed II*. The titular boxer (Michael B. Jordan) wore stars-and-stripes-patterned shorts based on the iconic shorts worn by his late father Apollo Creed (Carl Weathers) in *Rocky*, along with his blue and white shoes, while fighting in the ring. This lot consists of a pair of patriotically-themed polyester stunt boxing shorts labelled "Creed" on one side and "Johnson" (Adonis' deceased birth mother's name) on the other with "Stunt Dbl" hand-marked on the interior as well as a wardrobe tag hand-marked "Adonis Stunt Chg. 1 Dbl." Also included are a pair of white and blue Nike stunt boxing shoes (US size 10 hand-marked "Stunt Dbl." This costume originated from the VIP studio-sanctioned auction for *Creed*. The shoes exhibit some discolouration in the white areas.

**Estimate: £2,500 - 5,000**



**1006**  
Krite Puppet Head  
**Critters 4 (1992)**

A Krite puppet head from Rupert Harvey's *Critters 4*. The crew of the RSS *Tesla* battled alien Krites known as Critters aboard their ship in the year 2045. This detailed puppet head was designed and fabricated for the production by the Chiodo Brothers' "critters crew." It is constructed from foam moulded around metal puppeteer wires, dressed with synthetic black hair, painted in shades of mottled purple and blue with white fanged teeth, and inset with red plastic eyes. The paint exhibits extensive cracking and flaking, exposing the foam on the face, while the reverse is unpainted except for stray red paint stains from production. Dimensions: 20.5 cm x 18 cm x 11.5 cm (8" x 7" x 4.5")

**Estimate: £800 - 1,600**



**1007**  
T-Bird's (David Patrick Kelly) Screen-matched Jacket  
**The Crow (1994)**

T-Bird's (David Patrick Kelly) screen-matched jacket from Alex Proyas' *The Crow*. T-Bird wore his jacket when Eric Draven (Brandon Lee) taped him to a chair and killed him with explosives as revenge for attacking his fiancée. Distinctive patterning, the unique pattern of a tortoiseshell button, and distressing on the right-side jacket hem screen-match this jacket to when the grenade was placed between T-Bird's legs. This lot consists of a light brown leather jacket with a scale skin texture. The jacket features duct tape on the right side and tape residue across the left chest. This lot exhibits grime to the lining.

**Estimate: £1,000 - 2,000**



**1008**  
Diana's (Emma Corrin) Screen-matched "Gold Stick" Masquerade Costume  
**The Crown - Gold Stick (2020)**

Diana's (Emma Corrin) masquerade costume from *Series 4, Episode 1* of the historical drama television series *The Crown*, titled "Gold Stick". Diana wore her costume when she met Charles (Josh O'Connor) for the first time. The costume matches the one seen on screen by the placement of the applied fabric leaves and foliage. The costume consists of two green bodysuits, one decorated with leaves and vines and one plain, two pairs of green tights, green ballet slippers, and a leafy hat and eye mask. Also included is a bag of spare applique decorations and threads. As the glue has aged, it exhibits a loss of some of its adhesive properties. As such, a few leaves have fallen off, and the costume should be handled with care to avoid further damage.

**Estimate: £1,500 - 3,000**



**1009**  
The Queen's (Imelda Staunton) Screen-matched "Alma Mater" Exam Results Costume  
**The Crown - Alma Mater (2023)**

The Queen's (Imelda Staunton) screen-matched exam results costume from *Series 6, Episode 7* of the historical drama television series *The Crown*, titled "Alma Mater". The Queen wore her costume while the Royal family gathered round to hear William (Ed McVey) read out his exam results. The costume consists of a matching skirt and blouse, both blue with an orange and white floral tile print, and matches to the one seen on screen by the alignment of the pattern along the seams and hems. The skirt is pleated and lined with blue satin.

**Estimate: £1,000 - 2,000**



**1010**  
The Queen's (Olivia Colman) Pink Costume  
**The Crown - Margaretology (2019)**

The Queen's (Olivia Colman) pink costume from *series three, episode two* of the historical drama television series *The Crown*, titled "Margaretology". The Queen wore her outfit as she was being told news of the success of her sister Margaret's (Helena Bonham-Carter) tour of America. This costume was the only one made for the scene. The costume consists of a pink long-sleeved, knee-length dress, and a matching pink jacket. Both the jacket and dress feature false pockets.

**Estimate: £2,000 - 4,000**



**1011**  
 Diana's (Elizabeth Debicki) Screen-matched "Queen Victoria Syndrome"  
 Holiday Costume M  
**The Crown - Queen Victoria Syndrome (2022)**

"Diana's (Elizabeth Debicki) screen-matched holiday costume from Series 5, Episode 1 of the historical drama television series The Crown, titled "Queen Victoria Syndrome". Debicki was awarded the Emmy for Outstanding Supporting Actress in a Drama Series in 2024, and was nominated in 2023 for her portrayal of Diana, Princess of Wales. Diana wore her costume while on holiday with Charles (Dominic West) in Italy, where they argued about his scheduling conflicts cutting the holiday short.

The costume consists of a leopard print swimming costume and a matching leopard print chiffon sarong, and matches to the one seen on screen through the placement of the leopard-print patterning on the swimming costume. The sarong is sheer and has a knotted detail at the waist."

**Estimate: £1,500 - 3,000**

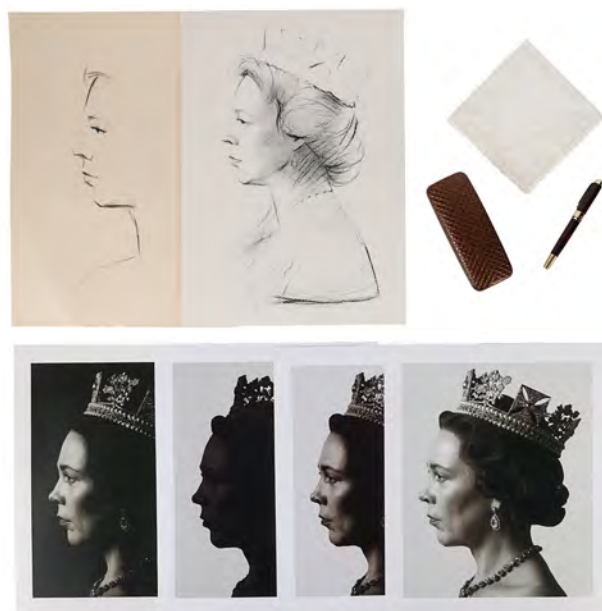

**1012**  
 The Queen's (Olivia Colman, Imelda Staunton)  
 Glasses Case, Pen, Hanky and Photos M  
**The Crown (T.V. Series, 2016-2023)**

The Queen's (Olivia Colman, Imelda Staunton) photos, glasses case, pen and monogrammed handkerchief from the historical drama series The Crown. The photos of varying sizes and lighting tones were used in the introductory scenes of Olivia Colman as the Queen, where she is seen approving her head profile for the updated postage stamp in the first episode of Series 3, titled "Olding." The Queen's signature brown textured glasses case was used by Imelda Staunton in the majority of episodes in Series 5 and 6. The Jinhao brand pen still contains an empty ink cartridge and was used in multiple episodes. It can clearly be seen on the Queen's desk in the Series 6 episode "Ruritania". The white handkerchief with lace edging was used in each of the six series and is embroidered with Elizabeth's royal cypher. Dimensions: 42 cm x 30 cm x 4 cm (16.5" x 12" x 1.75")

**Estimate: £1,500 - 3,000**



**1013**  
 Proof Sheet of Stamps M  
**The Crown (T.V. Series, 2016-2023)**

A proof sheet of stamps from the historical drama television series The Crown. Proof sheets were produced for the Queen's (Claire Foy) approval demonstrating how the completed stamps would look. The proof sheet consists of a single piece of A4 paper, headed with the royal coat of arms, onto which four stamps have been adhered, each a different postage class with a different colour background, all of which feature a profile shot of the Queen. Beneath the stamps printed text reads "1954 new stamp designs". The sheet exhibits some fold lines. Dimensions: 30 cm x 20 cm (12" x 8")

**Estimate: £300 - 600**

**1014**  
 Operation London Bridge Folder M  
**The Crown - Sleep, Dearie Sleep (2023)**

An Operation London Bridge folder from the final episode of the sixth series of the historical drama television series The Crown, titled "Sleep, Dearie Sleep." Operation London Bridge folders were used during meetings for the planning of the Queen's state funeral. The folder is A4 and bound in dark blue leather, with gold embossing on the front that reads "Operation London Bridge". 145 of the pages are populated with text regarding the funeral plans. The text has been duplicated across numerous pages to fill them. Dimensions: 32 cm x 22.5 cm x 5 cm (12.75" x 9" x 2")



**Estimate: £800 - 1,600**

**1015**  
 Buckingham Palace Floor Plans and Jubilee Routes M  
**The Crown - Hope Sleep (2023)**

Buckingham Palace floor plans and Jubilee routes from the historical drama television series The Crown. The Queen took part in planning her Golden Jubilee celebrations during the ninth episode of the sixth series, titled "Hope Street". This lot includes two versions of the floor plans, one framed and one not, and two versions of the Jubilee routes, both unframed and printed onto different sized paper. Both Jubilee route maps and the unframed floor plans have been hand-marked with red and black charcoal, and the markings differ between the two Jubilee maps. The framed floor plans are mounted in a wooden frame and unmarked. The unframed sheets have been folded for storage purposes, and where they have been folded some transfer of the charcoals have occurred. Dimensions: 32 cm x 22.5 cm x 5 cm (12.75" x 9" x 2")

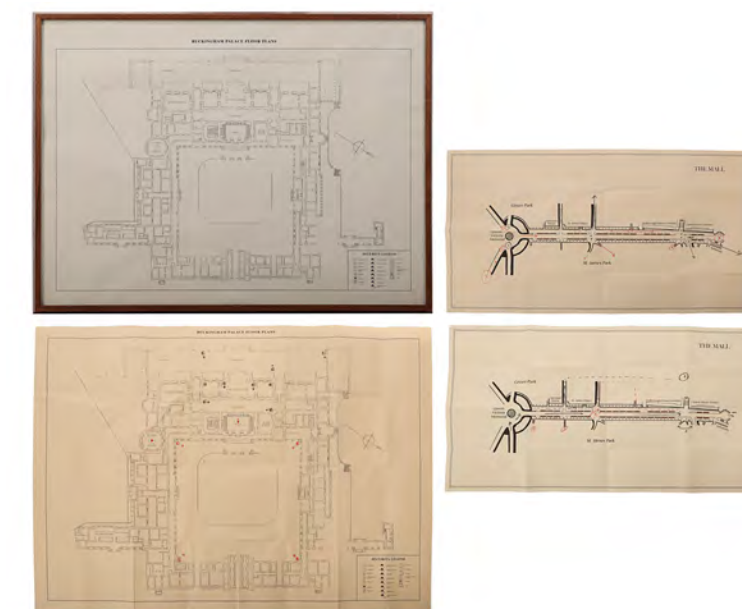

**Estimate: £300 - 600**

**1016**  
 Princess Diana (Emma Corrin/Elizabeth Debicki) Props M  
**The Crown (T.V. Series, 2016-2023)**

A selection of character props from the Emmy Award-winning portraits of Princess Diana (Emma Corrin/Elizabeth Debicki) in the historical drama television series The Crown. Diana (Emma Corrin) wrote in her blue notebook whilst receiving etiquette lessons at Buckingham Palace during her engagement to Charles (Josh O'Connor). It contains handwritten notes concerning Royal duties and etiquette and is featured in multiple scenes of the Series 4 episode "Fairytale". The speeches were used by Diana (Elizabeth Debicki) whilst preparing to address the press as part of a campaign for the Bosnian Landmine Removal Trust (Series 6 episode "Two Photographs"). One page is annotated with handwritten notes in black ink. Also included are Diana's signature-style Kensington Palace headed paper and notecards, which can be seen on her desk in various episodes. Dimensions: 34 cm x 24 cm x 2 cm (13.5" x 9.5" x 1")

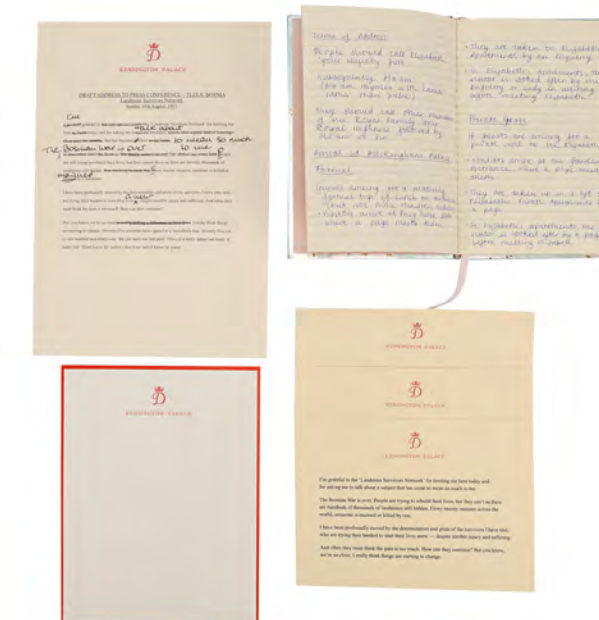

**Estimate: £600 - 1,200**



**1017**  
Margaret Thatcher's (Gillian Anderson) Screen-matched Skirt Suit †Δ  
**The Crown - War (2020)**

Margaret Thatcher's (Gillian Anderson) screen-matched skirt suit from series four, episode ten of the historical drama television series *The Crown*, titled "War". Thatcher wore her suit when privately receiving the Order of Merit from Queen Elizabeth (Olivia Colman), after stepping down as Prime Minister. The suit is navy blue, with a chequered pattern, and screen-matches through the way the pattern aligns along the seam of the sleeve, collar and around the buttonholes. The suit comprises a knee-length skirt and a matching blazer, both of which are silk-lined. There are two pieces of double-sided clear tape adhered to the inside of one lapel.

**Estimate: £1,000 - 2,000**

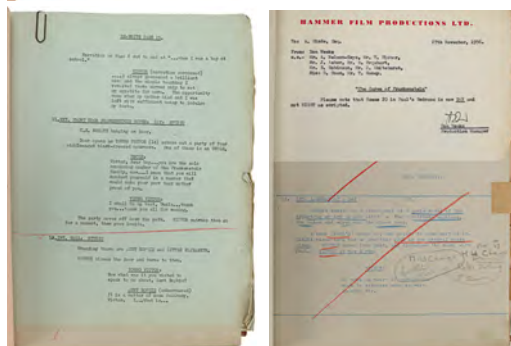
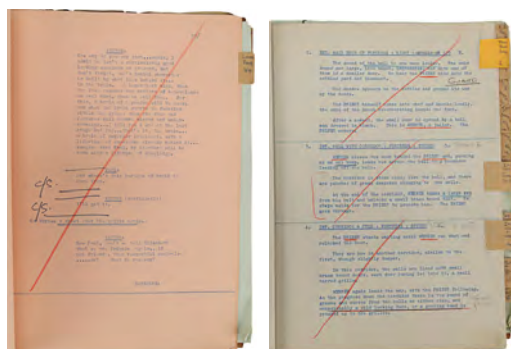

**1018**  
Production-used Script †M  
**The Curse Of Frankenstein (1957)**

A production used script from the production of Terence Fisher's Hammer horror film *The Curse of Frankenstein*. It was Hammer's first colour horror film, and directors such as Martin Scorsese and Tim Burton have paid tribute to it as an influence on their work. The script is titled "The Curse of Frankenstein" and credited to Jimmy Sangster, based on the story by Mary Shelley. The script belonged to Derek Whitehurst, the assistant director on the film, and features inserted notes from Don Weeks, the production manager, and Anthony Hinds, the producer. It is 117 pages long, 95 pages of which are annotated, and includes inserts from first and second revisions. It is bound in brown card covers, and some of the pages are torn. Dimensions: 28.5 cm x 24 cm x 2.5 cm (11.5" x 9.5" x 1")

**Estimate: £2,000 - 4,000**

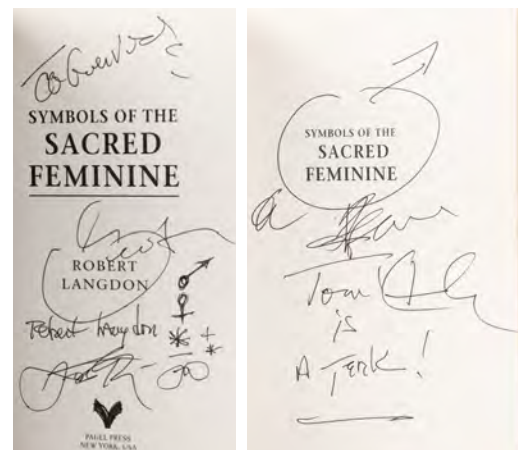
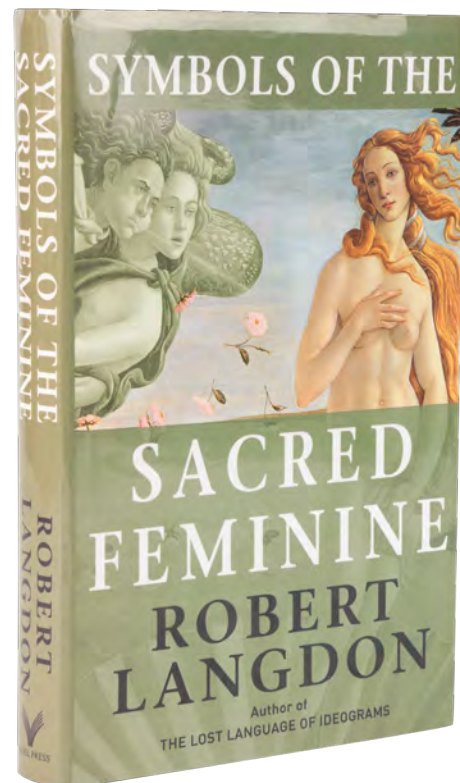

**1019**  
Robert Langdon (Tom Hanks) Signed Book †M  
**The Da Vinci Code (2006)**

A Robert Langdon (Tom Hanks) signed book from Ron Howard's mystery thriller sequel *The Da Vinci Code*. After delivering a lecture, Harvard professor Langdon signed copies of his book at a meet-and-greet in Paris. The book has been hand-signed with the character's signature in black ink on the main title page. The main bulk of pages inside are that of Mark Billingham's novel *Lifeless*. Dimensions: 24.75 cm x 16 cm x 3.5 cm (9.75" x 6.25" x 1.5") The autographs in this lot have been professionally authenticated by expert Garry King; see notice in the Buyer's Guide.

**Estimate: £1,000 - 2,000**

**1020**  
Pair of Gelfing Head Skins and Little Shop of Horrors Script and Storyboards †M  
**The Dark Crystal (1982)**

A pair of Gelfing foam heads from Jim Henson and Frank Ozand's fantasy film *The Dark Crystal*, accompanied by a production script and set of storyboards from Frank Oz's horror musical *Little Shop of Horrors*. The two Gelfing heads are made of foam rubber and would have been embellished in post-production with special effects. The storyboards from *Little Shop of Horrors* are printed, while the script of 113 pages has "Ammatronics" hand-written in the top right corner. Both Gelfing heads exhibit wear and deterioration due to age. Dimensions: (largest head) 21.5 cm x 10 cm x 19.5 cm (8.5" x 4" x 7.75")

**Estimate: £500 - 1,000**

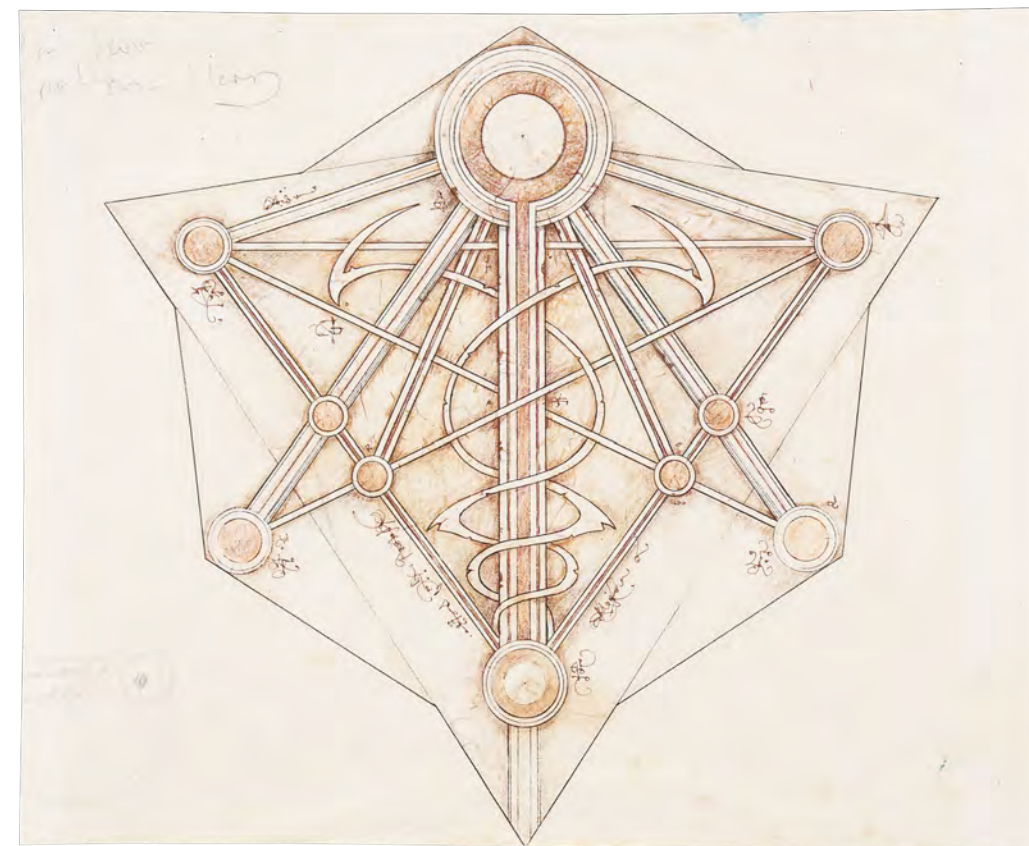

**1021**  
Hand-coloured Brian Froud "Skeksis Spiral Journey" Artwork †Δ  
**The Dark Crystal (1982)**

Brian Froud's Skeksis Throne Chamber floor-plan artwork from the production of Jim Henson and Frank Oz's dark fantasy film *The Dark Crystal*. This hand-coloured, production original artwork provides a floor-plan of the throne chamber in the Skeksis' castle. It features entwined serpents, together with inlaid circles within a triangle laid over a hexagram. Originally created by the urSkeks, the Skeksis' predecessor species, the throne room was intended to represent a great branching polyhedron of intertwined fates, with the circles representing focal points of the energy generated by the cosmic serpents. The print also features annotations by Froud, as well as text written in the language of the Skeksis. Dimensions: 14 cm x 29 cm (5.5" x 11.5") The autographs in this lot have been professionally authenticated by expert Garry King; see notice in the Buyer's Guide.

**Estimate: £2,000 - 4,000**

**1022**  
Mystic's SFX Enchantment Bowl M  
**The Dark Crystal (1982)**



A Mystic's SFX enchantment bowl from Jim Henson's fantasy film *The Dark Crystal*. On his deathbed, Mystic Master UrSu (Brian Muehl) used his enchantment bowl to reveal to the Gelfling Jen (performed by Jim Henson, Kathryn Mullen, Kiran Shah & voiced by Stephen Garlick) his destiny of "healing" the Dark Crystal by finding the lost shard. As UrSu reveals the prophecy, an illusion of the shard and the home of Ogra materialise out of the bowl. To create this illusion for the close up shots, the shard and Ogra's home were lowered into the liquid, which filled the bowl, and then played in reverse in post production. The Mystic's enchantment bowl is made of fibreglass, painted brown with a textured grain to imitate wood. It features spiral carvings around the exterior, three curved handles, three holes, and a thin spout protruding from the base. There are some glue remnants and areas of scuffing on the paintwork from production use and age. Dimensions: 45 cm x 45 cm x 29 cm (17.75" x 17.75" x 11.5")

**Estimate: £2,000 - 4,000**

**1023**  
Jim Henson-autographed Crew Photo, Partial Script and Crew Shirt M  
**The Dark Crystal (1982)**



A Jim Henson-autographed crew photograph, partial script and crew shirt from the production of his and Frank Oz's family fantasy film *The Dark Crystal*. The photograph reads "to Cheryl with love" in green marker pen then features Henson's autograph. This dedication was likely for his daughter, Cheryl Henson, a credited puppet builder on the production. The crew T-shirt is a women's size "M". The script has "Richard Slaughter" handwritten on the front page. Slaughter was credited as a Mystic Healer performer in the film. The script is from pages 9 to 74. Dimensions: 30 cm x 21 cm x 2 cm (11.75" x 8.25" x 0.75") The autographs in this lot have been professionally authenticated by expert Garry King; see notice in the Buyer's Guide.

**Estimate: £500 - 1,000**

**1024**  
UrSol's (Simon Williamson) Foot M  
**The Dark Crystal (1982)**



UrSol the Chanter's (Simon Williamson) foot from Jim Henson's fantasy film *The Dark Crystal*. UrSol was the gentle urRu chanter, whose evil Skeksis twin was skekSil the chamberlain. The foot is made of foam latex formed around a metal armature. It is dressed in leather wraps with decorative plastic beads. The foam has become fragile with age, crumbling around the toes and flaking away entirely in some places, exposing the armature beneath. As such, the lot should be handled with caution. The foot also exhibits an odour from storage. Dimensions: 43 cm x 17 cm x 14 cm (17" x 6.75" x 5.5")

**Estimate: £2,000 - 4,000**

**1025**  
Harry Lange Hand-sketched Artwork M  
**The Dark Crystal (1982)**

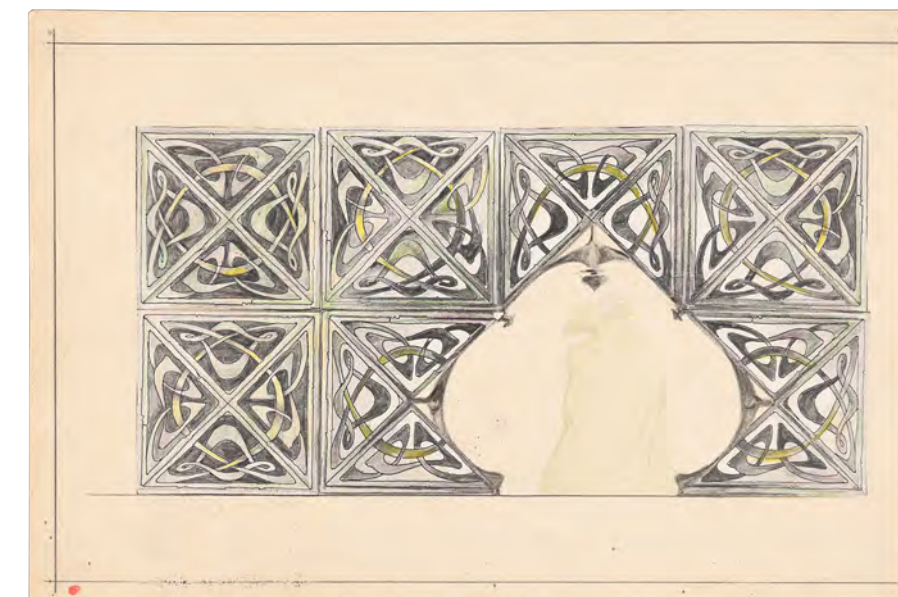

A piece of hand-sketched artwork by Academy Award-nominee Harry Lange from the production of Frank Oz and Jim Henson's fantasy film *The Dark Crystal*. Lange, the film's production designer, hand-sketched this design in pencil on paper that has been adhered to a piece of card. It appears to be a design for a wall within an interior scene. An opening in the wall shows the faint sketch of a Skeksis creature. Dimensions: 36 cm x 24 cm (14.25" x 9.5") Sold without copyright; see copyright notice in the Buyer's Guide.

**Estimate: £800 - 1,600**

**1026**  
Podling Hat M  
**The Dark Crystal (1982)**



A Podlin hat from Frank Oz and Jim Henson's fantasy film *The Dark Crystal*. Many of the Podlings wore beanie hats as the Garthim raided their village. The hat is wool with faux leather straps hanging down each side.

**Estimate: £800 - 1,600**

**1027**  
Production Storyboards M  
**The Dark Crystal (1982)**

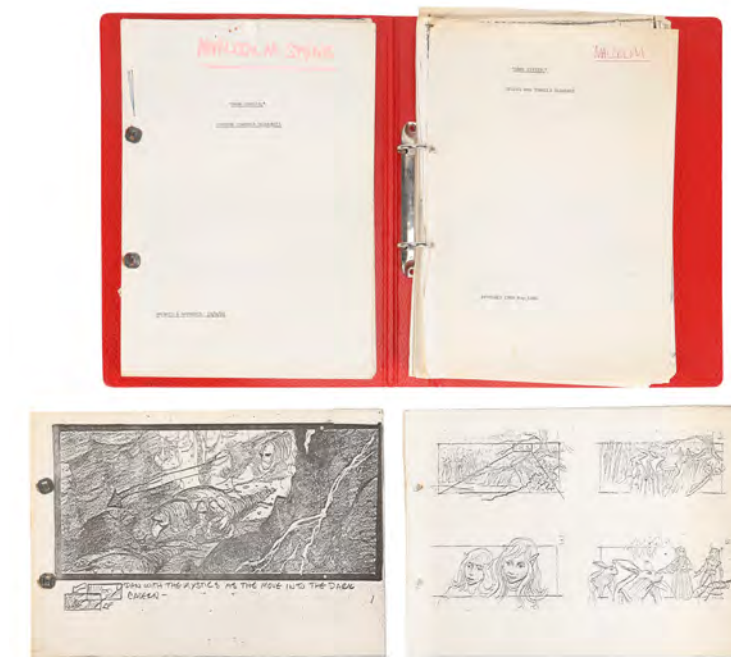

Production storyboards from the production of Jim Henson and Frank Oz's dark fantasy film *The Dark Crystal*. Included in this lot are 131 pages of storyboards created for the film. The storyboards were created for the sewers and tunnels sequence and the chamber sequences of the film, and are printed in black and white, with brief descriptions of the action taking place in each panel. The chambers sequence storyboards are marked as having been approved on "15/4/81", and the sewers and tunnels sequences were approved on "19th May 1981". Some of the pages are handmarked "Malcolm Stone", who served as the art director on the film, and the majority are appended with scene numbers. The storyboards are bound in a red ring-binder folder. Also included are two shooting schedule pages. The printing quality varies somewhat between pages, and they exhibit some minor tears and dog-earing, but otherwise remain in good condition. Dimensions: 31 cm x 24.5 cm x 5 cm (12.25" x 9.75" x 2")

**Estimate: £800 - 1,600**



2.18 m (7.14')

**1028**  
Barnabas Collins' (Johnny Depp) Coffin †  
**Dark Shadows (2012)**

Barnabas Collins' (Johnny Depp) coffin from Tim Burton's comedy *Dark Shadows*. After being inadvertently released in 1972, vampire Collins was once again imprisoned in a coffin by witch Angelique (Eva Green) after rejecting her numerous seductive advances. The large gothic piece is constructed from fibreglass with braces and rivets cast into the form. The fibreglass lid opens via a set of large metal hinges and has corresponding latches on the opposite edge, with a number of metal hoops and brackets along the centre of the side panels. The inside is decorated to match the exterior, with several layers of black foam lining the base for the performer's comfort. The coffin is stored inside the original wooden production transport crate, which includes the movie title stencilled in paint on the sides. Dimensions: (crate) 218 cm x 86 cm x 89 cm (85.75" x 35" x 33.75") Special shipping required; see special shipping notice in the Buyer's Guide.

**Estimate: £2,000 - 4,000**



**1029**  
Kapitänleutnant Henrich Lehmann-Willenbrock's (Jürgen Prochnow) Leather Jacket †  
**Das Boot (1981)**

Kapitänleutnant Henrich Lehmann-Willenbrock's (Jürgen Prochnow) leather jacket from Wolfgang Petersen's wartime epic *Das Boot*. The Kapitänleutnant wore a grey jacket onboard his crew's U-boat during a close encounter with a passing British destroyer in the Atlantic Ocean. The double-breasted leather jacket is lined with a woollen blanket material in wartime fashion and features metal buttons. A costume label in the left-sided inside pocket reads "Herr Jurgen" and "5313 No.1" in print. This label originates from Berman & Nathans. The jacket exhibits dirt marks and white scuffs from age, and the button at the top of the midriff section is missing.

**Estimate: £1,000 - 2,000**



**1030**  
Ryan Reynolds and Josh Brolin Autographed One Sheet Poster †Δ  
**Deadpool 2 (2018)**

A Ryan Reynolds and Josh Brolin signed One Sheet poster for David Leitch's superhero action-comedy sequel *Deadpool 2*. The poster's design uses a photograph taken by Michael Muller, depicting Reynolds, Brolin, and Zazie Beetz (Domino) in character. It has been hand-signed below the film's title in black ink by both Reynolds and Brolin. Dimensions: 101.5 cm x 68.5 cm (40" x 27") The autographs in this lot have been professionally authenticated by expert Garry King; see notice in the Buyer's Guide.

**Estimate: £500 - 1,000**



**1031**  
Tuvia Bielski's (Daniel Craig) Screen-matched Jacket †Δ  
**Defiance (2008)**

Tuvia Bielski's (Daniel Craig) jacket from Edward Zwick's World War II drama *Defiance*. Tuvia wore his costume, designed by Academy Award-winner Jenny Beavan, while endeavouring to survive and protect his Jewish comrades from the Nazis during the occupation of Belarus. The costume includes a brown leather jacket which matches the one seen on screen through its distinctive creases, bobbles and markings. "Daniel Craig" is handwritten in ink on a label inside the jacket's collar, and "No 1" is handwritten beside this on the inner lining in marker pen. The costume also comprises a green cotton blazer; a leather belt attached to a faux gun holster made of hard rubber; a cotton pinstripe shirt; and a linen scarf. The holster exhibits a hole on its underside where a gun's barrel would sit.

**Estimate: £2,000 - 4,000**



**1032**  
Alfredo Garcia's (Benjamin Bratt) Hero Communicator Ω  
**Demolition Man (1993)**

Alfredo Garcia's (Benjamin Bratt) hero communicator from Marco Brambilla's sci-fi action comedy *Demolition Man*. Garcia wore his communicator as part of his SAPD uniform throughout the film. The communicator is strapped across the body, and worn on the shoulder. It consists of leather straps and metal hardware, and features a number of buttons and the SAPD logo. The buttons do not depress, and on the rear side of the device the name "Garcia" is written in very faded ink. It comes with a plaque that declares it screen-used. Dimensions: 37 cm x 6 cm x 4 cm (14.5" x 2.5" x 1.5")

**Estimate: £500 - 1,000**



**1033**  
Male SAPD Uniform and Stunt Baton Ω  
**Demolition Man (1993)**

A male SAPD uniform and stunt baton from Marco Brambilla's sci-fi action comedy *Demolition Man*. Officers in the San Angeles Police Department wore their uniforms while on duty. The costume consists of a shirt, which matches the serial number of Alfredo Garcia (Benjamin Bratt) and is labelled "Paul"; a pair of trousers (labelled "#6"); a belt ("Men's Street Med 34-35"); and a rubber stunt taser baton. The shirt has some sun bleaching along the left shoulder and arm, and the baton has some paint wear. Dimensions (baton): 58 cm x 7 cm x 7 cm (22.75" x 2.75" x 2.75")

**Estimate: £2,000 - 4,000**





**1034**  
 Dexter Morgan's (Michael C. Hall) SFX Scalpel and Straight Razor  $\Omega$   
**Dexter - Dexter (2006)**

Dexter Morgan's (Michael C. Hall) SFX scalpel and straight razor from James Manos, Jr.'s Dexter. Dexter, a forensic technician for the Miami Metro Police Department, hunted fellow serial killers with his blood spatter analysis instruments throughout the series, including when he tortured Mike Donovan (Jim Abele) with his scalpel in the series premiere episode "Dexter." This lot comes from the collection of renowned special effects artist Tom "Brooklyn" Bellissimo. It consists of a stainless steel Thermo Electron 745 surgical scalpel and a steel Magic straight razor, both with clear plastic SFX blood pipettes glued to their undersides. Both instruments exhibit adhesive and blood residue, while the razor's pipette has come loose. Dimensions: (largest) 24.25 cm x 1 cm x 3.25 cm (9.5" x 1.25" x 0.25") Blades were dulled by production. Edged, bladed or blunt object; see notice on Blades in the Buyer's Guide. This lot comes from the collection of renowned special effects artist Tom "Brooklyn" Bellissimo. A letter of authenticity from Bellissimo is included.

**Estimate: £2,500 - 5,000**

**1035**  
 Zeus' (Samuel L. Jackson) Bloodied Torn Shirt  $\mathcal{M}$   
**Die Hard With A Vengeance (1995)**

Zeus' (Samuel L. Jackson) bloodied torn shirt from John McTiernan's action thriller film Die Hard with a Vengeance. Zeus wore his shirt throughout the film after being slashed with a knife while saving John McClane (Bruce Willis) from a gang in Harlem, as he and McClane carried out the tasks laid before them by Simon (Jeremy Irons.) The shirt features a torn right sleeve and blood stains down the right-hand side, with the sleeve cut off where Zeus received treatment for his wounds. The shirt is a white Fifth Avenue shirt (size 16"-36"), with "Zeus" handwritten in black ink on the label. It exhibits some dirtying and discoloration from production, but otherwise remains in very good condition.

**Estimate: £1,500 - 3,000**



**1036**  
 Weta Workshop ARC Generator Replica  $\mathcal{M}$   
**District 9 (2009)**

A Weta Workshop replica of an ARC generator from Neill Blomkamp's Academy Award-nominated District 9. Wikus van der Merwe (Sharlto Copley) discovered he could wield Prawn weaponry after he was subjected to alien experiments at Multinational United (MNU). This cast metal replica was based on the original production weapons. Weta intentionally distressed this weapon to give it the appearance of oozing alien gunk out of its couplings and markings. The replica is accompanied by its original packaging and a pair of small display platforms that can be attached to a wall. The lot exhibits a break in the wire at the end of the barrel, as well as scuffing and chipped paint. Dimensions: 101 cm x 10.75 cm x 36.5 cm (39.75" x 4.25" x 14.25")

**Estimate: £1,500 - 3,000**



**1037**  
 Django's (Jamie Foxx) Knife and Sheath  $\mathcal{M}$   
**Django Unchained (2012)**

Django's (Jamie Foxx) hero knife and sheath, from Quentin Tarantino's revisionist Western Django Unchained. Django took his knife from the men escorting him and other slaves to the mines, after proving he was a free man and bounty hunter. The knife is an 'Aussie knife', with a finger guard notch where the blade meets the handle. It is made of resin, with the blade painted to look metallic and the handle painted to look like elk antler. The sheath is made of brown leather, and has a leather belt loop affixed to the open end. Dimensions: 35.5 cm x 8 cm x 5 cm (14" x 3.25" x 2") Edged, bladed or blunt object; see notice on Blades in the Buyer's Guide.

**Estimate: £2,000 - 4,000**

**1038**  
 Pack of Red Apple Cigarettes With Pouches and Matches  $\Omega$   
**Django Unchained (2012)**

A pack of Red Apple cigarettes with a pouch and matches from Quentin Tarantino's Django Unchained. Django (Jamie Foxx) lit a cigarette in Calvin Candie's Julius Caesar room at the Cleopatra Club where he hosted a Mandingo fight of his slave Big Fred (Escalante Lundy) against Amerigo Vesepi's (Franco Nero) slave Luigi (Clay Donahue Fontenot). Created by property master Hope Parrish, this lot consists of one brown paper-wrapped Red Apple cigarette pouch with a production-made label; a box of Gas Light matches; two empty cream muslin Red Apple tobacco pouches, and one herb-filled pouch. This lot exhibits minor scuffing to the match box, minor loose threads to the pouches, and discoloration. Dimensions: (largest) 9.75 cm x 14.75 cm x 0.75 cm (3.75" x 5.75" x 0.25")

**Estimate: £1,000 - 2,000**



**1039**  
 Django Freeman's (Jamie Foxx) Shot Glasses and Broomhilda von Shaft's (Kerry Washington) Freedom Papers with Production Ephemera  $\Omega$   
**Django Unchained (2012)**

Django Freeman's (Jamie Foxx) shot glasses and Broomhilda von Shaft's (Kerry Washington) freedom papers with assorted production ephemera from Quentin Tarantino's Django Unchained. Django had a shot in Calvin Candie's (Leonardo DiCaprio) Julius Caesar room at the Cleopatra Club, where Candie hosted a Mandingo fight before Django convinced him to sign freedom papers for Broomhilda, his wife. Created by property master Hope Parrish, this lot consists of two clear glass shot glasses; three folded freedom papers, including one sealed with a red wax seal, featuring both printed text and the handwritten signatures of Candie and his lawyer Leonide Moguy (Dennis Christopher); four red wax pens with typed instructions; three cream muslin Red Apple tobacco pouches; a package of Bugler cigarette papers; a metal and red resin Golden Melody harmonica; and a dynamite bundle made of wooden rods wrapped in wax dipped paper and tied together with twine. This lot exhibits tarnishing on the harmonica and grime on the shot glasses. Dimensions: (largest) 30.5 cm x 30.5 cm x 15.25 cm (12" x 12" x 6")

**Estimate: £1,000 - 2,000**





**1040**  
 Pack of Red Apple Cigarettes With Pouches  
 and Matches  $\Omega$   
**Django Unchained (2012)**

A pack of Red Apple cigarettes with pouches and matches from Quentin Tarantino's Django Unchained. Django (Jamie Foxx) lit a cigarette in Calvin's Candie's Julius Caesar room at the Cleopatra Club where he hosted a Mandingo fight of his slave Big Fred (Escalante Lundy) against Amerigo Vespepi's (Franco Nero) slave Luigi (Clay Donahue Fontenot). Created by property master Hope Parrish, this lot consists of one brown paper-wrapped Red Apple cigarette pouch with a production-made label; a box of High Jump safety matches; and two cream muslin Red Apple tobacco pouches with one yellow print vinyl logo and one screenprint logo. This lot exhibits minor scuffing to the match box and minor loose threads to the pouches. Dimensions: (largest) 9.75 cm x 14.75 cm x 0.75 cm (3.75" x 5.75" x 0.25")

**Estimate: £800 - 1,600**

**1043**  
 Original Production Script  $\mathcal{M}$   
**Doctor Who Original Series - Centre of Terror (1965)**

A rehearsal script from the production of episode six, series five of the original Doctor Who television series. Credited to Bill Strutton, the script is titled "Ep. 6 "Centre of Terror". This episode aired on 20 March 1965, when William Hartnell played the Doctor. Printed on the front cover are rehearsal and transmission dates, with cast and crew lists. The script is 48 pages long, 20 of which are annotated, and originates from the collection of Catherine Fleming, who provided the voice of the Animus for the episode. The script exhibits considerable wear from age, including discolouration and staining on the pages, as well as dog-earing and minor tears. Dimensions: 34 cm x 21 cm x 1 cm (13.5" x 8.25" x 0.5")

**Estimate: £2,000 - 4,000**

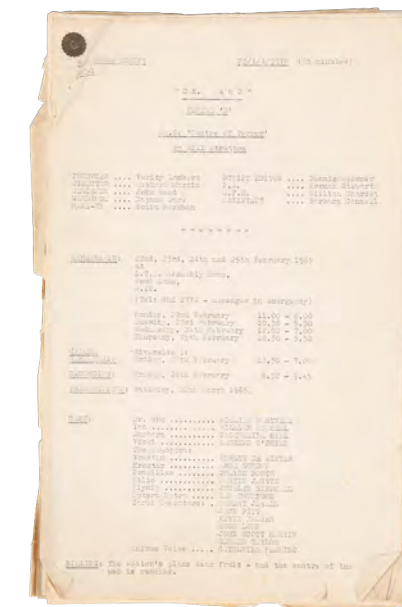

**1042**  
 Replica Cyberman Costume Display with Light-up Gun  $\mathcal{M}$   
**Doctor Who Original Series - Earthshock (2019)**

A replica Cyberman costume display with a light-up Cyber-gun from the original Doctor Who four-part Series 19 episode "Earthshock". The show adopted this style of Cyberman for their appearances between series 19 and 25. The costume is comprised of a screen-accurate R.A.F MK.2c flight suit with correct vintage string vest embellishments, painted silver colour to appear metallic, with vintage gloves and boots. The suit is adorned with a chest plate made of fibreglass, the same material used for the helmet. The gun is predominantly plastic with a wooden handle, all painted to resemble metal. The gun's light is powered by eight AA batteries, which can be inserted when the gun is unscrewed at its approximate midsection. The light then flashes when its black flick switch is held down. The ensemble was made by Sevans Models to a very high standard. The costume is mounted on a custom mannequin and the fabric pieces exhibit cracks in their paintwork. Dimensions (display): 32 cm x 70 cm x 200 cm (12.5" x 27.5" x 78.75") Contains electronics; see electronics notice in the Buyer's Guide. Special shipping required; see special shipping notice in the Buyer's Guide.

**Estimate: £2,500 - 5,000**

**1041**  
 Wong's (Benedict Wong) Light-up  
 Eldritch Spell Disc  $\Omega$   
**Doctor Strange (2016)**

Wong's (Benedict Wong) light-up Eldritch spell disc from Scott Derrickson's Doctor Strange. When Wong activated a spell, a glowing discus appeared before his hands. This lot consists of one clear acrylic disc inlaid with eclectic wire in an intricate pattern. The discus features a brown leather hand-strap attached to the centre on the backside, and is powered by a black battery pack with an on/off switch. This lot exhibits some scuffing and scratches to the acrylic and notable tape around the edges. Dimensions: 25.5 cm x 25.5 cm x 2.5 cm (10" x 10" x 1") Contains electronics; see electronics notice in the Buyer's Guide.

**Estimate: £800 - 1,600**

**1044**  
 Two Clapperboards  $\mathcal{M}$   
**Doctor Who - The Christmas Invasion (2005), New  
 Earth (2006)**

Two clapperboards from the production of the BBC sci-fi television series Doctor Who. Both clapperboards are made of acrylic, with wooden clappers. The production name "Doctor Who II" and the names of the director (James Hawes) and cameraman (Ernie Vincze) are written on both in black marker. Each clapperboard features the date of its last use: "22.07.05" on the smaller board, and "23-08-05" on the larger board, meaning both were used in filming the initial two episodes of the second series, which introduced David Tennant as The Doctor. Both clapperboards exhibit surface scratching. The larger one features faded writing designating the slate number ("55"), take number ("2") and roll number ("93"). The clapper on the smaller board is removable. Dimensions: 32.5 cm x 38.5 cm x 5 cm (15" x 12.5" x 3.5")

**Estimate: £2,000 - 4,000**



**1045**  
 Hand-Drawn Tardis Console Concepts  $\mathcal{M}$   
**Doctor Who (T.V. Series,  
 2005-Present)**

Hand-drawn TARDIS console concept art from the production of the sci-fi television series Doctor Who. This lot consists of four hand-drawn concept drawings of the TARDIS time machine's control console, drawn on white paper with black ink. All the art was drawn by Dan Walker, an award-winning concept artist whose credits include Alien: Covenant, Justice League, and Guardians of the Galaxy. These pieces were used to conceptualise the ninth Doctor's TARDIS control console. Three of the four drawings are annotated by Walker, and all four are dated "14.06.04". The drawings are titled "TARDIS Console #1", "TARDIS Console #2", "TARDIS Console #3" and "TARDIS Console #4", respectively. Dimensions (each): 42 cm x 59.5 cm (16.5" x 23.5"). Sold without copyright; see copyright notice in the Buyer's Guide.

**Estimate: £600 - 1,200**

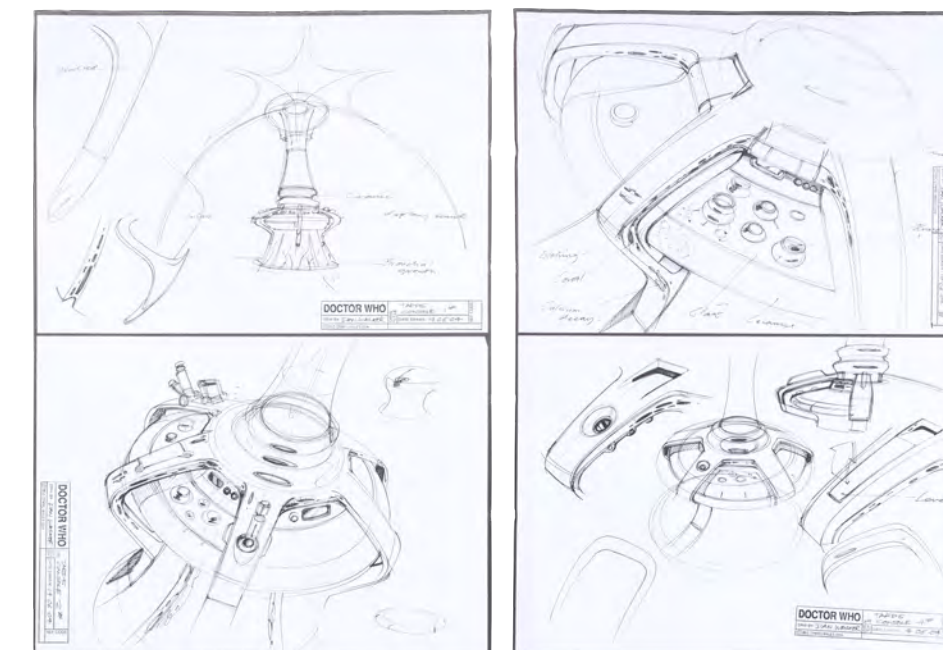

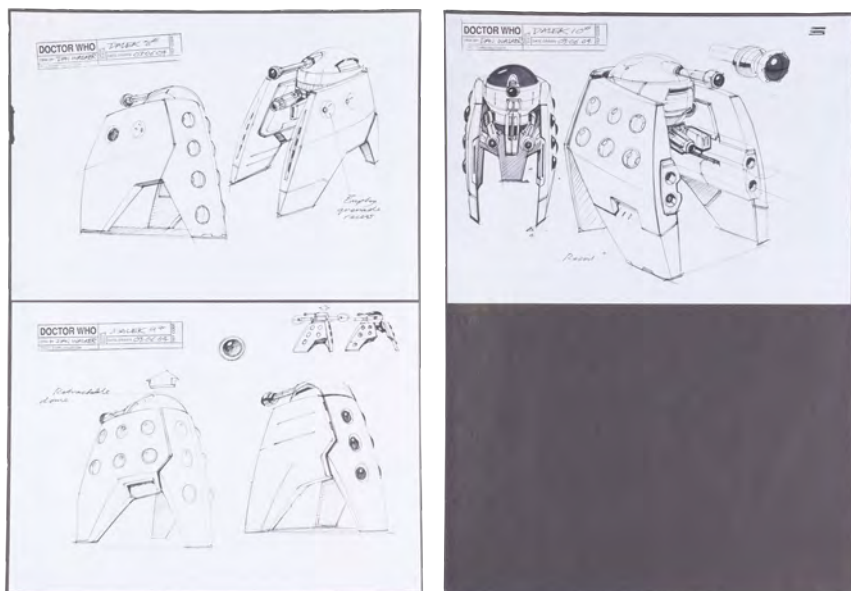

**1046**  
Hand-drawn Dalek Concepts M  
Doctor Who (2005 - Present)

Hand-drawn Dalek concept art from the production of the sci-fi television series Doctor Who. This lot consists of three hand-drawn concept drawings of the alien race known as the Daleks, drawn on white paper with black ink. All the art was drawn by Dan Walker, an award-winning concept artist whose credits include Alien: Covenant, Justice League, and Guardians of the Galaxy. These pieces were used to conceptualise the Daleks' first appearance in the ninth Doctor's term during the episode "Dalek". Each of the drawings is annotated by Walker, and every piece is dated "03.06.04". The drawings are titled "Dalek #8", "Dalek #9", and "Dalek #10", respectively. Dimensions (each): 42 cm x 59.5 cm (16.5" x 23.5") Sold without copyright; see copyright notice in the Buyer's Guide.

**Estimate: £600 - 1,200**



**1047**  
Monk Mask and Set of Three Truth Posters M  
Doctor Who (T.V. Series, 2005-Present)

A Monk mask and three Truth posters from the production of the sci-fi television series Doctor Who. The Monks were an alien race who used a virtual simulation of life on Earth in order to plan an invasion, and chose their particular appearance on Earth to resemble human corpses. Made of foam latex, the mask has the name "Sam" handwritten on the inside. The posters each feature an image of the Monks, and the word "TRUTH". One is mounted on a wooden backboard, the other two are unmounted. The mounted poster exhibits some staining, and a minor tear along the top edge. Dimensions (mask): 40 cm x 27 cm x 21 cm (16" x 11" x 8.5")

**Estimate: £1,200 - 2,400**

**1048**  
Dalek Gun M  
Doctor Who (T.V. Series, 2005-Present)

A Dalek arm from the production of the sci-fi television series Doctor Who. The Daleks were first introduced in episode six of the first of the revived series, when the Doctor (Christopher Eccleston) encounters an imprisoned Dalek kept in the Vault - a museum of artefacts and specimens from space. The arm is made of metal, resin and rubber, and comes in two parts - the length of the arm, which features a ball joint on one end, and the suction cup "hand". Dimensions: 51 cm x 9 cm x 9 cm (20" x 3.5" x 3.5")

**Estimate: £800 - 1,600**



**No lot 1049**

**1050**  
Collection of Time Travel Evidence Photos M  
Doctor Who - Rose (2005)

A collection of time travel evidence photos from the production of series 1, episode 1 of the BBC sci-fi television series Doctor Who, titled "Rose", which originally aired on the 26 March 2005. Rose Tyler (Billie Piper) was shown the pictures by Clive (Mark Benton), a conspiracy theorist, whilst searching for information about the mysterious Doctor (Christopher Eccleston). The images place the Doctor at a number of historical events, including the assassination of John F. Kennedy, the sinking of the Titanic, and the 1883 eruption of the Krakatoa. The latter image is a print of a sketch, whilst the others are photographs. Some of the photographs are alternates that did not make the final cut. Dimensions (largest): 37.5 cm x 27.5 cm (15" x 11")

**Estimate: £400 - 800**



**1051**  
Eleventh Doctor's (Matt Smith) Spacesuit Helmet M  
Doctor Who - The Doctor, the Widow and the Wardrobe (2011)

The Eleventh Doctor's (Matt Smith) spacesuit helmet from the 2011 Christmas Special episode of the sci-fi television series Doctor Who, titled "The Doctor, the Widow and the Wardrobe". The Doctor wore his helmet when he met Madge Arwell (Claire Skinner), who helped him find his TARDIS after he was involved in a spaceship explosion. This was one of two helmets made for Smith's Doctor. This helmet was made for studio filming, and differs slightly from the helmet made for location filming - it is possible to see out of the rear of the location filming helmet, but not possible to see out of the rear of the studio filming helmet. The helmet is made of resin, and painted a metallic grey. The visor moves, but the panel underneath has been blacked out. There is foam padding around the neck for the comfort of the wearer, and a label inside reads "Hero helmet" and "The Doctor." The helmet exhibits some paint chipping and scuffing, but otherwise remains in overall very good condition. Dimensions: 40 cm x 32 cm x 40 cm (15.75" x 12.5" x 15.75")

**Estimate: £1,000 - 2,000**





**1052**  
Tardis Roundel Piece M  
**Doctor Who (T.V. Series, 2005–Present)**

A TARDIS roundel piece from the sci-fi television series Doctor Who. Roundel pieces like this one decorated the walls of the TARDIS throughout the seventh series, during which the Eleventh Doctor (Matt Smith) helmed the TARDIS. The roundel piece is made of resin, with a hole in the top that is covered over with a translucent yellow plastic, through which lights would have been projected during the filming of the show, though no lights come with the piece. The item exhibits some dirt and paint splatter from production use, but otherwise remains in very good overall condition. Dimensions: 34 cm x 46 cm x 39 cm (13.5" x 18" x 15.5")

**Estimate: £1,000 - 2,000**



**1053**  
Exhibition K-9 M  
**Doctor Who (T.V. Series, 2005–Present)**

An exhibition K-9 from the sci-fi television series Doctor Who. This K-9 was used in the "Doctor Who Up Close" exhibition in Land's End, one of a few exhibitions of its kind, which displayed numerous props and costumes from the series. The K-9 is in the style it appeared in during the episode School Reunion, after which the K-9 Mark III was destroyed and replaced with a newer model. The K-9 is made of resin, painted to look like metal that is rusting in places, and is hollow inside. Around its neck is a tartan collar with a blank dog tag. The tail and ears move, but all other parts are static. There is an array of lights on the K-9's back panel, though these are unwired and do not illuminate. The side panel reads "K-9". Dimensions: 116 cm x 40 cm x 70 cm (45.75" x 15.75" x 27.5")

**Estimate: £2,000 - 4,000**



**1054**  
Cast-Autographed Clapperboard M  
**Doctor Who (T.V. Series, 2005–Present)**

A cast-autographed clapperboard from the production of the sci-fi television series Doctor Who, notably the series featuring Peter Capaldi as the twelfth iteration of the eponymous Doctor. The clapperboard has been autographed by several notable cast members, including Capaldi (The Doctor), Jenna Coleman (Clara), and Julian Bleach (Davros). The names of each cast member who has autographed the clapperboard are written in print on the reverse side. Dimensions: 28 cm x 23.5 cm x 2 cm (11" x 9.25" x 0.75") The autographs in this lot have been professionally authenticated by expert Garry King; see notice in the Buyer's Guide.

**Estimate: £2,000 - 4,000**

**1055**  
Creature Head M  
**Doctor Who - The Magician's Apprentice (2015)**

A creature head from the Season 9 episode "The Magician's Apprentice", of the revived BBC sci-fi series Doctor Who. Dalek agent Colony Sarff (Jami Reid-Quarrell) questioned various alien creatures in the Maldovarium bar as they searched for The Doctor (Peter Capaldi). The head is made of foam latex and resin, with primate-like features and a pair of adhered ear defender-like components connected via a plastic tube, which have been painted to look like rusted metal. The head exhibits some damage – there are instances of paint damage, the ear defenders are beginning to come away from the rest of the head, and there is a split up the back, which has been patched over with a fabric lining. Dimensions: 47 cm x 32 cm x 28 cm (18.5" x 12.5" x 11")

**Estimate: £1,000 - 2,000**



**1056**  
Silurian Hunter Mask M  
**Doctor Who (T.V. Series, 2005–Present)**

A Silurian Hunter mask from the sci-fi television series Doctor Who. Silurian Hunters wore their tribal masks during their appearances in the fifth and sixth series. This mask is made of fibreglass and is painted to look like metal. It has foam padding on the inside for the comfort of the actor and Velcro strips where it was attached to the rest of the head. "Alex" is handwritten inside. Dimensions: 18 cm x 19.5 cm x 20 cm (7" x 7.75" x 7.75")

**Estimate: £1,000 - 2,000**



**1057**  
The Doctor's (Peter Capaldi) Yoyo M  
**Doctor Who - Kill the Moon (2014)**

A yoyo from series eight, episode seven of the revival series of the sci-fi television show Doctor Who, named "Kill the Moon". While on the moon, the Twelfth Doctor (Peter Capaldi) used a yoyo to inspect irregularities in gravity. The yoyo is made of plastic with a metallic centre and a reel of thin acrylic string. It has been painted yellow. The string is slightly tangled, and the item exhibits minor paint wear. Otherwise, it remains in very good condition. Dimensions: 6 cm x 6 cm x 4 cm (2.5" x 2.5" x 1.5")

**Estimate: £1,000 - 2,000**





**1058**  
Roboform Helmet m  
**Doctor Who - The Runaway Bride (2006)**

A roboform helmet from the 2006 Christmas special episode of the revived sci-fi television series Doctor Who, named "The Runaway Bride". Roboforms throughout the episode were disguised as Santa Claus, but their true appearance was discovered by Donna Noble (Catherine Tate) when she pulled off the disguise of the roboform driving her taxi. The helmet, made by effects house Millennium FX, is made of fibreglass and felt-lined, with the eye and mouth holes covered with mesh, and a Velcro chin strap which is hand-inscribed "KEN H" for actor Ken Hosking. Dimensions: 30 cm x 22 cm x 18 cm (12" x 8.75" x 7")

**Estimate: £2,000 - 4,000**

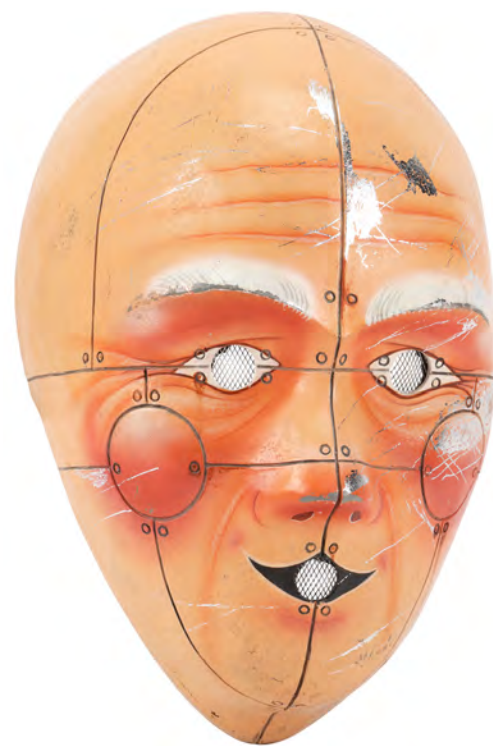

**1059**  
Screen-matched Robot Santa Mask m  
**Doctor Who - The Christmas Invasion (2005)**

A robot Santa mask from "The Christmas Invasion", the 2005 Christmas Special episode of the sci-fi BBC television series Doctor Who. Roboforms wore Santa masks throughout the episode to blend in with the festive surroundings, before attacking with their lethal musical instruments. Scratches on the face of this mask, sustained when the roboform was struck down by a falling Christmas tree, screen-match it to one seen in the episode. The mask is made of padded leather, with grates over the eye and mouth holes. A handwritten interior label reads "BBCW009475". Aside from the deliberate scratching sustained during production, it remains in excellent condition. Dimensions: 25 cm x 20 cm x 12 cm (10" x 8" x 4.75")

**Estimate: £3,000 - 6,000**

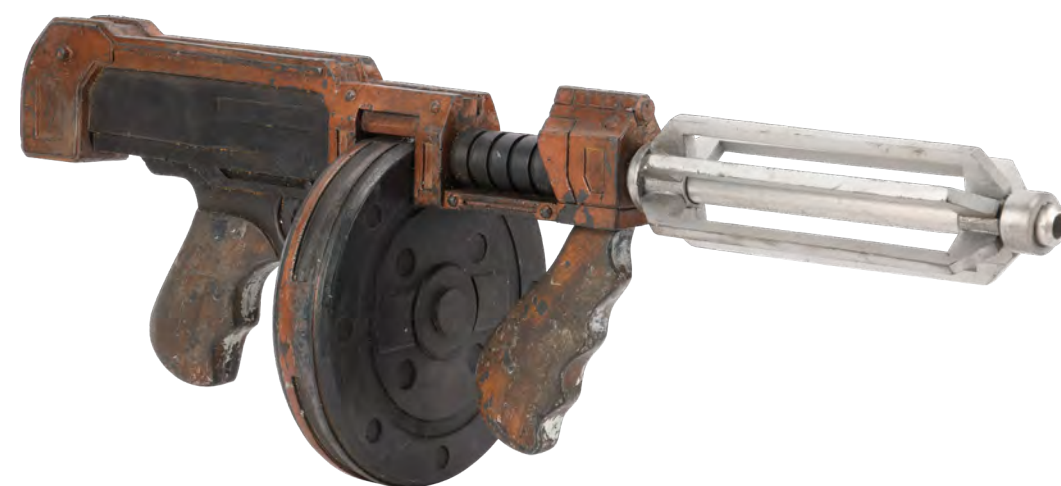

**1060**  
Dalek-Human Tommy Gun m  
**Doctor Who - Evolution of the Daleks (2007)**

A Human Dalek Tommy gun from the fifth episode of the third series of the revived British science fiction television series Doctor Who, named "Evolution of the Daleks". Dalek-enhanced Tommy Guns were energy weapons created by the Cult of Skaro to arm their human-Dalek army in their bid to conquer Earth in 1930 and create the New Dalek Empire. The weapon, the design for which was based on a hybrid of a Thompson submachine gun and a Dalek gun stick, is constructed from deliberately weathered resin, painted to look metallic, and wood. Dimensions: 65 cm x 22 cm x 20 cm (25.5" x 8.75" x 8")

**Estimate: £2,000 - 4,000**

**1061**  
Screen-matched Light-up Dalek Dome m  
**Doctor Who (T.V. Series, 2005-Present)**

A screen-matched light-up Dalek dome from the sci-fi TV series Doctor Who. In the ninth Christmas special episode, "The Time of the Doctor," three Daleks ambushed The Doctor (Matt Smith) before he saved Tasha Lem (Orla Brady).

Distinct scuffs and scratches on the dome match it as belonging to the middle Dalek seen on screen during the above-mentioned scene. The dome is made of fibreglass and painted a bronze colour. The lights on the top of the head illuminate when powered. Inside the dome a piece of tape is hand-labelled "Head 1 2013". The piece has been intentionally distressed with some grime and scratches, and has additional production wear, including paint wear. Dimensions: 56 cm x 52 cm x 20 cm (22" x 20.5" x 8")

Contains electronics; see electronics notice in the Buyer's Guide.

**Estimate: £2,500 - 5,000**



**1062**  
Donnie Brasco's (Johnny Depp) FBI ID m  
**Donnie Brasco (1997)**

Donnie Brasco's (Johnny Depp) FBI ID from Mike Newell's biographical crime drama Donnie Brasco. FBI agents revealed Donnie's true identity to Sonny Black (Michael Madsen) and his crew with black-and-white pictures, one of which depicted him holding up his FBI badge. The two ID papers related to Brasco's real identity, special agent Joseph D. Pistone, include one with a photograph of Depp and are held inside a leather wallet. The character's signature has been handwritten in black ink on the bottom ID paper. Dimensions: 19.75 cm x 14 cm x 1.25 cm (7.75" x 5.5" x 0.5")

**Estimate: £3,000 - 6,000**



**1063**  
Robert Crawley's (Hugh Bonneville) Ceremonial Jacket and Shirts +  
**Downton Abbey (T.V. Series, 2010-2015)**

Robert Crawley's (Hugh Bonneville) ceremonial uniform series two of Downton Abbey. Crawley wore his ceremonial uniform on special occasions, including a concert to help fund the local hospital, which was treating officers wounded in the First World War. The costume consists of two white shirts, one khaki shirt, a military dress jacket with matching trousers, a black waistcoat, and brown leather lace-up boots. The jacket features a number of service medals attached to the left lapel, as well as badges sewn onto both lapels and across the epaulettes. The trousers have two handwritten labels that read "1 Robert" and "Hugh Bonneville" stitched into the waistband. The khaki shirt also features a label, reading "Smith 71".

**Estimate: £1,000 - 2,000**



**1064**  
Robert Crawley's (Hugh Bonneville) British Army Full Dress Uniform + **Downton Abbey (T.V. Series, 2010-2015)**

Robert Crawley's (Hugh Bonneville) British Army full dress uniform from the second series of the historical drama television series Downton Abbey. Crawley wore his uniform throughout the second series for dinners and special occasions, as the First World War raged. The costume consists of a red jacket with a silver collar and cuffs, navy trousers with a red stripe down the side of each leg, a white shirt, a silver belt, white gloves, black boots, and a cocked hat with a plume. The jacket features a label which reads "Hugh Bonneville July 2013" and the trousers feature a label which reads "Tim Piggott Smith Aug 16". Piggott Smith also appeared in the series, and it is possible a component of his costume was used to complete this one. The shirt is size "17", and the hat has labels inside which read "Hugh Bonneville" and "Military Mob". Also included are a replacement belt buckle and replacement buttons. The boots and belt exhibit minor wear.

**Estimate: £1,500 - 3,000**



**1065**  
Robert Crawley's (Hugh Bonneville) Military Uniform + **Downton Abbey (T.V. Series, 2010-2015)**

Robert Crawley's (Hugh Bonneville) military costume from the second series of the historical television drama Downton Abbey. Crawley wore his uniform throughout the series, as the First World War raged, in place of his usual smart attire. The costume consists of a green military-style jacket, beige trousers, a beige shirt (Size 40), a khaki tie, a green military cap, and blue bracers. Inside the interior pocket of the jacket is a production label which reads "1 Robert," and sewn into the waistband of the trousers a handwritten label reads "Hugh Bonneville Jan 2011." The trousers feature a lace-up detailing down the sides of the calves.

**Estimate: £1,500 - 3,000**

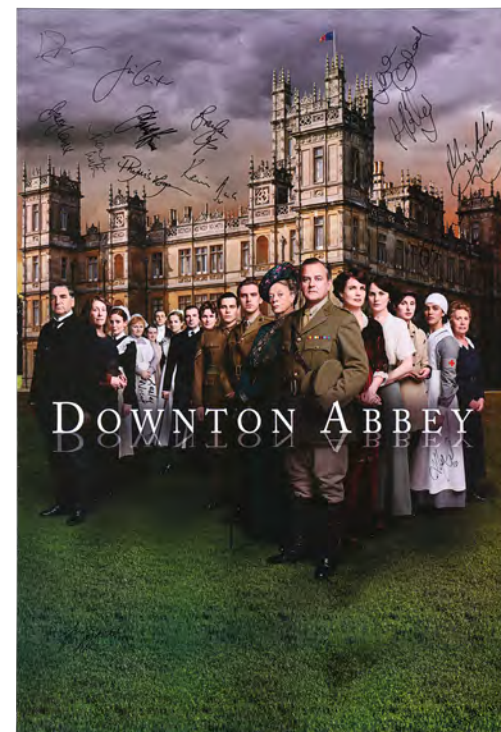

**1066**  
Cast Autographed Poster + **Downton Abbey (T.V. Series, 2010-2015)**

A cast autographed poster from the period television series Downton Abbey. This poster shows the series main characters standing outside the eponymous abbey, and is autographed in black ink by 16 cast members: Michelle Dockery (Lady Mary Crawley), Brendan Coyle (John Bates), Joanne Froggatt (Anna Bates), Laura Carmichael (Lady Edith Crawley), Elizabeth McGovern (Cora Crawley), Penelope Wilton (Isobel Crawley), Robert James Collier (Thomas Barrow), Jim Carter (Charles Carson), Lesley Nichol (Mrs Patmore), Allan Leech (Tom Branson), Lily James (Lady Rose MacClare), Kevin Doyle (Joseph Molesley), Raquel Cassidy (Baxter), Daisy Lewis (Sarah Bunting), and one unidentified cast member. Dimensions: 101.5 cm x 68.5 cm (40" x 27") The autographs in this lot have been professionally authenticated by expert Garry King; see notice in the Buyer's Guide.

**Estimate: £500 - 1,000**

**1067**  
Thing 1's (Danielle C. Ryan) Costume + **Dr. Seuss' The Cat In The Hat (2003)**

Thing 1's (Danielle C. Ryan) costume from Bo Welch's fantasy comedy Dr. Seuss' The Cat in the Hat. Thing 1 and Thing 2 (Brittany Oaks) wore their costumes as they wrecked the Waldens' house after the Cat (Mike Myers) released them from a crate. The custom-made red stretch fleece-like jumpsuit features a padded collar and the "Thing 1" emblem on the rear side can be partially removed via several popper fastenings to unzip the rear zip fully. Two intentional holes are located at the hips to allow the use of a harness. Handwritten text reading "Danielle Harness" is located inside the zip, along with a red "Rita Ryack, C.D.G" costume tag. A small hole is present at the top of the zip.

**Estimate: £400 - 800**



**1068**  
SFX Lawmaster Bike + **Dredd (2012)**

A SFX Lawmaster bike from Pete Travis' sci-fi action film Dredd. The Judges travelled around Mega-City One on their Lawmaster bikes as they tackled crime in the violent metropolis. The bike's main body is made of fibreglass with a black finish and red trim. It features a leather seat, a metal Judge emblem, a pair of metal handlebars with brake triggers and rubber grips, a transparent acrylic panel at the front, and numerous buttons. The front panel contains emergency-vehicle lights, which would have been activated by the buttons found in the handlebar region. Some of the wires that powered the bike's features remain, but are untested. The bike is fixed onto a metal gimbal that allowed it to be moved on its axis while being filmed for close up shots. The bike's body exhibits scuffs and scratches, which were intentionally caused by the production, to make it appear damaged from vehicle chases and combat. Contains electronics; see electronics notice in the Buyer's Guide. Special shipping required; see special shipping notice in the Buyer's Guide.

**Estimate: £3,000 - 6,000**



**1069**  
Harkonnen Knife and Sheath + **Dune (1984)**

A Harkonnen knife from David Lynch's epic space opera film Dune. Soldiers of House Harkonnen, as well as Feyd-Rautha (Sting) and Glossu-Rabban Harkonnen (Paul L. Smith), carried knives distinctive to their house throughout the film. The knife is made of resin, painted to look metallic, and the blade has an iridescent quality. Also included is a leather sheath, with resin detailing painted to look golden. The blade exhibits significant paint wear, and the holster exhibits wear on the leather. Dimensions: 30 cm x 6 cm x 2 cm (12" x 2.5" x 1")

Payment plans are not available for this lot. Please contact us for further information.

**Estimate: £1,000 - 2,000**





**1070**  
Harkonnen Pistol and Holster m  
**Dune (1984)**

A Harkonnen pistol and holster from David Lynch's epic space opera film Dune. Soldiers of House Harkonnen, as well as Feyd-Rautha (Sting) and Glossu-Rabban Harkonnen (Paul L. Smith), carried pistols distinctive to their house throughout the film. Included in this lot are a leather holster and a resin gun. The gun has been painted black and exhibits significant paint damage and chipping, and the holster has metal fastenings, some of which have rusted slightly. Dimensions: 31 cm x 16 cm x 10 cm (12.25" x 6.5" x 4")

Payment plans are not available for this lot. Please contact us for further information.

**Estimate: £2,000 - 4,000**



**1071**  
Sardaukar Pistol and Holster m  
**Dune (1984)**

A Sardaukar pistol and holster from David Lynch's epic space opera film Dune. The Sardaukar were the elite military force of the emperor of the Padishah Emperor, and responsible for the attack on House Atreides on Arrakis. Included in this lot are a leather holster and a resin gun. The gun has been painted black and silver-colour and exhibits significant paint damage and chipping, and the holster has metal fastenings, some of which have rusted slightly. Dimensions: 33 cm x 16 cm x 5 cm (13" x 6.5" x 2")

Payment plans are not available for this lot. Please contact us for further information.

**Estimate: £2,000 - 4,000**



**1072**  
Space Guild Translator ω  
**Dune (1984)**

A Space Guild translator from David Lynch's Dune. After arriving at Padishah Emperor Shaddam IV's (Jose Ferrer) throne room, the Space Guild used their translators to communicate with Shaddam about the conspiracy he had planned. Custom-made for production but differing from the versions seen in the final cut, this futuristic cast resin translator device originated from the collection of production illustrator Ron Miller. It is painted black with a receiver side and a speaker side featuring three prongs with a stacked torus-like shape. This translator exhibits discolouration, chipped paint, pitting, and a buildup of grime. Dimensions: 29.25 cm x 29.25 cm x 15.25 cm (11.5" x 11.5" x 6")

**Estimate: £2,500 - 5,000**

**No Lot 1073**

**1074**  
Cast-Autographed Poster †  
**Dune: Part Two (2024)**

A cast-autographed poster for Denis Villeneuve's sci-fi remake sequel Dune: Part Two. This release date promotional poster, vibrant with orange glows synonymous with the franchise's story world, is autographed in black marker by Timothee Chalamet (Paul Atreides), Austin Butler (Feyd-Rautha), Zendaya (Chani), Josh Brolin (Gurney Halleck) & Stellan Skarsgård (Baron Harkonnen). Villeneuve is the second director to adapt Frank Herbert's classic sci-fi novel, following David Lynch, whose adaptation hit the big screen in 1984. Unlike his predecessor, Villeneuve has split the story into two parts, the first of which received 10 nominations at the 2022 Academy-awards, picking up wins in six categories. Dimensions: 101 cm x 68 cm (39.75" x 26.75") The autographs in this lot have been professionally authenticated by expert Garry King; see notice in the Buyer's Guide.

**Estimate: £1,000 - 2,000**



**1075**  
Simon Aumar's (Justice Smith)  
Spell Components Dispenser and  
Red Wizard Gold Bullion m  
**Dungeons & Dragons: Honour  
Among Thieves (2023)**

Simon Aumar's (Justice Smith) spell components dispenser and a piece of Red Wizard gold bullion from Jonathan Goldstein and John Francis Daley's fantasy adventure comedy Dungeons & Dragons: Honour Among Thieves. Half-elf sorcerer Simon used his spell components dispenser throughout the film, and Harper agent Edgin (Chris Pine) stole a bullion of Red Wizard gold, leading to the death of his wife. The dispenser is made of resin and features loops on the back to attach to a belt. The gold bullion is also resin and features a deer motif on the front. Dimensions (dispenser): 11.5 cm x 10 cm x 4 cm (4.5" x 4" x 1.5")

**Estimate: £2,000 - 4,000**





**1076**  
Commander Bolton's (Kenneth Branagh) Military Overcoat, Hat and Jumper + Dunkirk (2017)

Commander Bolton's (Kenneth Branagh) military overcoat, hat and jumper from Christopher Nolan's World War II drama Dunkirk. Commander Bolton oversaw the evacuation of Allied troops from the town of Dunkirk while the German army closed in on them. The matching overcoat and hat are both made from wool, with metal features such as buttons and emblems. The coat also has military badges at the shoulders. The jumper is made of white wool, and is marked size "2". Some of the military badges have become partially unstitched from the coat.

**Estimate: £3,000 - 6,000**



**1077**  
Cast-Autographed US One Sheet m E.T. The Extra-Terrestrial (1982)

A US One Sheet for Steven Spielberg's sci-fi adventure E.T. The Extra-Terrestrial, autographed by main members of the cast. The poster depicts Alvin's iconic artwork of the 'finger touch', which was inspired by Michelangelo's ceiling painting of the Sistine Chapel. Matthew DeMeritt (E.T.), Henry Thomas (Elliott), Peter Coyote (Keys), Dee Wallace (Mary), Robert MacNaughton (Michael), and C. Thomas Howell (Tyler) have signed the poster in silver marker pen. The actors have also written famous quotes from their respective characters on the poster, such as "Be good", "Where's it from? Uranus? Get it? Your anus?", "You have absolute Power" and "Of course he can talk". Dimensions: 104.25 cm x 68.5 cm (41" x 27") The autographs in this lot have been professionally authenticated by expert Garry King; see notice in the Buyer's Guide.

**Estimate: £500 - 1,000**



**1078**  
Rita Vrataski's (Emily Blunt) VFX Helicopter Blade Sword m Edge Of Tomorrow (2014)

Rita Vrataski's (Emily Blunt) VFX helicopter blade sword from Doug Liman's Edge of Tomorrow. Vrataski carried a large black blade out on the battlefield as she fought against alien Mimics. Production utilised blades such as this during scenes where they used CGI. This half-blade is made of foam with a rigid top coat painted predominately black with a resin handle wrapped with black electrical tape, painted black with silver-colour applied on top to appear metallic. This lot exhibits pitting in the blade and chipped paint. Dimensions: 62.25 cm x 15.25 cm x 5 cm (24.5" x 6" x 2")

**Estimate: £4,000 - 8,000**

**1079**  
Cage's (Tom Cruise) Hero Exosuit Arm m Edge Of Tomorrow (2014)

William Cage's (Tom Cruise) hero exosuit arm from Doug Liman's sci-fi action film Edge of Tomorrow. Alongside Rita Vrataski (Emily Blunt), Cage fought the invading alien army with the aid of an exoskeleton battle suit. Rather than use CGI to create these suits, Liman had real, physical suits made. Cruise performed all of his own stunts for the film while wearing the suit, which weighed around 85 pounds. This arm is made primarily of solid resin, with metallic fixtures and foam padding for the comfort of the wearer. Dimensions: 16 cm x 46 cm x 14 cm (6.5" x 18" x 5.5")

**Estimate: £2,000 - 4,000**



**1080**  
Screen-Matched "Fighting For Tomorrow" Poster m Edge Of Tomorrow (2014)

A screen-matched "Fighting for Tomorrow" poster from Doug Liman's sci-fi action film Edge of Tomorrow. Posters featuring Rita Vrataski (Emily Blunt) adorned walls around the military base where Cage (Tom Cruise) was stationed, most notably where Cage was confronted by Skinner (Jonas Armstrong). This screen-matches a poster in this scene though the notable tear in the top left corner, creasing and staining from getting wet. The poster has been intentionally distressed, and has additional wear from use in the rain-soaked scene. Dimensions: 117 cm x 82 cm (46" x 32.25")

**Estimate: £1,500 - 3,000**



**1081**  
Grenades, Panels and Passes m Edge Of Tomorrow (2014)

Grenades, panels and passes from Doug Liman's sci-fi action film Edge of Tomorrow. UDF soldiers made use of panels and passes during their time on base, and Cage (Tom Cruise) used grenades to destroy the Omega mimic and stop the time loops. Included are two grenades - one hero, one stunt - two UDF touchscreen panels, a UDF pass, and a folder. The hero grenade is made of metal, while the stunt grenade is made of resin. The panels are acrylic and both feature a printed keypad to mimic a touchscreen display. The pass is also acrylic and features the UDF logo and details of a staff member who was not featured on screen. The folder contains various paperwork featuring graphs and instructional text. The text and graphs have been duplicated across some of the pages. The grenades exhibit some paint wear, and the folder some dirt, but otherwise all the items remain in very good condition. Dimensions: 36 cm x 15 cm x 22 cm (14.25" x 6" x 8.75")

**Estimate: £1,000 - 2,000**







**1082**  
Collection of UDF Grenades m  
**Edge Of Tomorrow (2014)**

A collection of UDF grenades from Doug Liman's sci-fi adventure Edge of Tomorrow. The United Defense Forces soldiers fought with futuristic grenades against Mimics throughout the film. The collection comprises four green and yellow hard rubber grenades with metal pins and clips; two grey resin grenades; two black hard rubber grenades with metal pins; two green and black resin grenades; one hard rubber grey grenade embellished with orange tape and remnant sand in its crevices; one black hard rubber grenade with a metal pin. Dimensions: (largest grenade) 6.5 cm x 5.5 cm x 17 cm (2.5" x 2.25" x 6.75")

**Estimate: £2,500 - 5,000**

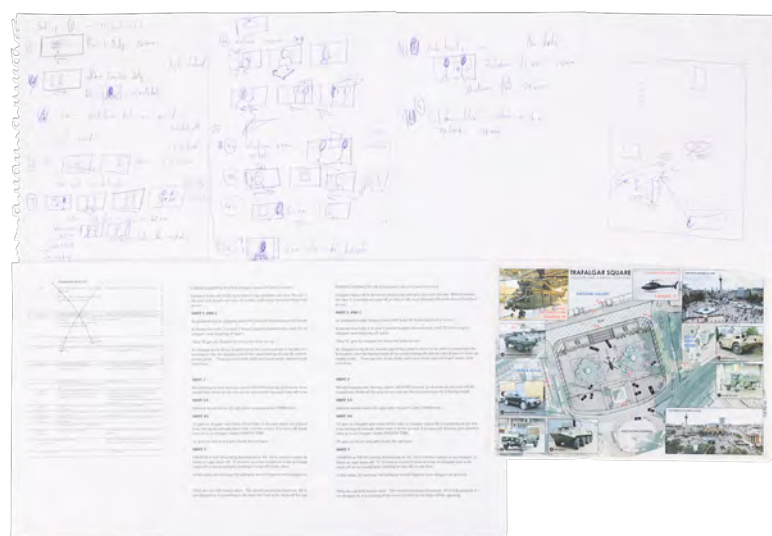

**1083**  
Doug Liman's Director Notes m  
**Edge Of Tomorrow (2014)**

Doug Liman's director notes from the production of his sci-fi action film The Edge of Tomorrow. The lot includes three pages of hand-drawn storyboards with handwritten notes about lens sizes and camera movements, all in blue and black ink; one hand-drawn shot plan in blue ink; three printed shot lists for a Trafalgar Square sequence; and one printed shot plan of Trafalgar Square featuring images of military vehicles used in the production. Dimensions: 35 cm x 23 cm x 1.5 cm (13.75" x 9" x 0.5")

**Estimate: £500 - 1,000**

**1084**  
Collection of UDF Equipment and Exosuit Components m  
**Edge Of Tomorrow (2014)**

A collection of UDF equipment and exosuit components from Doug Liman's sci-fi action film Edge of Tomorrow. Together with their UDF comrades, Sergeant Rita Vrataski (Emily Blunt) and Major William Cage (Tom Cruise) wore heavily armed exosuits as they fought off the Mimic invasion. The exosuit components are comprised of one large aluminium round; seven magazines, three made of foam rubber, four made of foam, and two made of wood; one foam rubber shoulder strap handle; two faux LED screen devices, one resin, the other hard rubber; and three foam rubber suit pieces. The UDF equipment consists of one camo-patterned backpack with a "Technical Order" badge attached; a metal cyclic stick with various switches; an inflatable vest pack bag; and one plastic brake coolant tank with a rubber tube attached. The brake coolant tank exhibits a small hole towards its bottom end. Dimensions (cyclic stick): 80 cm x 53 cm x 9.5 cm (31.5" x 20.75" x 3.75")

**Estimate: £2,000 - 4,000**



**1085**  
Pair of Propaganda Posters m  
**Edge Of Tomorrow (2014)**

A pair of propaganda posters from Doug Liman's 2014 action sci-fi film Edge of Tomorrow. Paper propaganda posters in various languages depicting war hero Sergeant Rita Vrataski (Emily Blunt) were seen throughout Earth during the Mimic's invasion. Both posters exhibit large tears, which were likely to have been intentionally caused by the production so that they appeared congruent with the rest of the war-torn sets. Dimensions (one poster): 119 cm x 82 cm (46.75" x 32.25")

**Estimate: £1,000 - 2,000**



**1086**  
Stunt Exosuit Harness and Pack m  
**Edge Of Tomorrow (2014)**

A stunt exosuit harness and pack from Doug Liman's 2014 action sci-fi film Edge of Tomorrow. UDF soldiers, including Major William Cage (Tom Cruise), wore heavily armed exosuits as they fought off the Mimic invasion. The harness and pack are made of foam rubber, while the pack features a foam underside. The items have been painted to look like metal, with the harness handles painted yellow. Dimensions (pack): 41 cm x 41 cm x 15.5 cm (16.25" x 16.25" x 6")

**Estimate: £1,000 - 2,000**



**1087**  
Elizabeth I's (Helen Mirren) Crown and Set of Three Dresses + Elizabeth I (T.V. Series, 2005)

Elizabeth I's (Helen Mirren) crown and dresses from the historical drama television series Elizabeth I. Elizabeth wore her dresses and crown throughout the series, as she navigated possible marriage alliances and her tempestuous relationships with her favourites, Leicester (Jeremy Irons) and Essex (Hugh Dancy). Included in this lot are three dresses, one yellow, one green, one white, and a metal crown. The dresses are each in two parts, a skirt and a bodice, and each features a handwritten costing label that reads "Elizabeth I Helen Mirren". All three are embellished with faux gemstones and embroidered details. The crown is lined with leather and padded with foam for the comfort of the wearer, and exhibits minor wear.

**Estimate: £500 - 1,000**





**1088**  
The Man's (Gabriel Byrne) Costume Ω  
**End Of Days (1999)**

The Man's (Gabriel Byrne) costume from Peter Hyams' End of Days. Upon reaching Earth, Satan possessed an investment banker (Gabriel Byrne) who wore a dark suit throughout the film until he abandoned the banker's badly injured body in pursuit of Christine York (Robin Tunney). This costume consists of a black suit jacket from Academy Award Clothing marked "ECC" on the inner pocket and in the armpit in black ink; a dark grey, button-up shirt from Alfani; matching black suit trousers marked "No. 1" on the interior waistband; and a pair of black leather shoes. This costume exhibits a hole in the shirt with frayed fabric and pulled threads.

**Estimate: £1,500 - 3,000**

**1089**  
Knife, Folder, Magazine, Grenades, Heart Necklace, and Crucifix Ω  
**End Of Days (1999)**

A knife, folder, magazine, grenades, heart necklace, and crucifix from Peter Hyams' End of Days. Vatican knights ambushed Christine York's (Robin Tunney) home to stop Satan (Gabriel Byrne), a former client of Jericho Cane (Arnold Schwarzenegger), from creating a world of evil with York. Created by property master Hope Parrish, this lot consists of a metal blade knife with a black and grey painted and textured resin handle; one grey manila folder stamped "CONFIDENTIAL" with a Stricker Security sticker featuring 14 pages of information on Satan; a TIME magazine dated January 3, 2000 featuring the apocalypse on the cover; two red and yellow metal grenades; one tarnished metal grenade shell; a metal heart and dagger necklace with a metal chain; and a gold- and silver-colour painted resin crucifix. This lot exhibits stains on the folder, chipped paint on the grenades and crucifix, and grime on the knife and necklace. Dimensions: (largest) 24.25 cm x 30 cm x 0.75 cm (9.5" x 11.75" x 0.25")

**Estimate: £800 - 1,600**

**1090**  
Archangel Michael Statue Sword Ω  
**End Of Days (1999)**

An Archangel Michael statue sword from Peter Hyams' End of Days. Jericho (Arnold Schwarzenegger) sacrificed himself on the sword attached to the fallen statue of Michael the Archangel to save Christine (Robin Tunney) and prevent Satan's (Gabriel Byrne) plan from coming to fruition at the end of the film. This silver-colour longsword is made of resin and features an intricate and decorative hilt. It exhibits chipped paint on the hilt and discoloration on the blade. Dimensions: 134.75 cm x 29.5 cm x 4 cm (53" x 11.5" x 1.5") Edged, bladed or blunt object; see notice on Blades in the Buyer's Guide.

**Estimate: £600 - 1,200**



**1091**  
Ender Wiggin's (Asa Butterfield) BDU Costume and a Flash Suit with Helmet Ω  
**Ender's Game (2013)**

Ender Wiggin's (Asa Butterfield) BDU (Basic Duty Uniform) costume and a flash suit with a helmet from Gavin Hood's 2012 young adult sci-fi adventure Ender's Game. Ender wore this style of BDU costume during the final test battle, while flash suits were worn by students during the Battle Room training sequences. The BDU costume comprises a slate blue jacket made from synthetic fabric with rubber emblems, a pair of matching trousers, a cotton turtleneck T-shirt, and a pair of black leather combat boots (size UK 6). "Ender" is handwritten in black ink on labels inside the jacket and trousers, while "ASA" is handwritten in black ink on a label inside the turtleneck T-shirt. The flash suit consists of a jacket made of synthetic nylon with yellow rubber pads, a pair of matching trousers and gloves, a pair of boots constructed from a pair of Rhino shoes (size EUR 46), a dark grey balaclava, and a helmet. "Kelvin Harrison" is handwritten in ink inside the jacket, boots and gloves. Harrison played a Salamander soldier in the film. The flash-suit helmet is made of resin with a clear acrylic visor and was cast from 3D-printed master patterns specifically sized to fit the actor. A hidden switch and battery compartment operate a functional internal fan powered by a 9V battery. "Tiger 2S" is handwritten inside the helmet in white marker pen. Contains electronics; see electronics notice in the Buyer's Guide.

**Estimate: £3,000 - 6,000**



**1092**  
John Kruger's (Arnold Schwarzenegger) Marshal ID and EMT Badge †Δ  
**Eraser (1996)**

John Kruger's (Arnold Schwarzenegger) Marshal ID and EMT badge from Chuck Russell's action thriller Eraser. Kruger showed his Marshal ID when he entered the Department of Justice government building at the film's opening. He later wore an EMT badge as part of his disguise while infiltrating the Cyrez Corporation. The Marshal ID comprises a faux leather wallet containing a laminated ID paper and a laminated certificate, each featuring handwritten signatures in blue ink. Formal information is filled out on the ID in black ink. Interestingly, the character's surname is spelled wrong on the ID paper. The EMT badge comprises a laminated paper ID featuring a picture of Schwarzenegger and a metal-and-plastic clip. The Marshal ID is missing its metal emblem from the space in the front of the wallet. Dimensions (Marshal ID): 13.75 cm x 9.5 cm x 1.25 cm (5.4" x 3.75" x 0.5")

**Estimate: £2,000 - 4,000**



**1093**  
Snake Plissken's (Kurt Russell) Jumpsuit Ω  
**Escape From L.A. (1996)**

Snake Plissken's (Kurt Russell) jumpsuit from John Carpenter's Escape from L.A. Plissken wore his jumpsuit while traversing the perilous island that was once Los Angeles on a mission forced onto him by the United States government. This lot consists of a grey synthetic-blend jumpsuit with a black mesh overlay, boot stirrups, and fastening strip segments around the waist and thighs. The interior is hand-marked "Kurt - Hero" and "1/16/96." It exhibits some wear from use and age, including pulling in the mesh near the collar and smudging to the marking.

**Estimate: £1,200 - 2,400**



**1094**  
Sigrit Ericksdottir's (Rachel McAdams) Screen-matched Costume Pieces and Erick Ericksson's (Pierce Brosnan) Screen-matched Cardigan †  
**Eurovision Song Contest: The Story Of Fire Saga (2020)**

Sigrit Ericksdottir's (Rachel McAdams) screen-matched costume pieces and Erick Ericksson's (Pierce Brosnan) screen-matched cardigan from David Dobkin's musical comedy Eurovision Song Contest: The Story of Fire Saga. Sigrit wore her various costume pieces throughout the film, with the long wool cardigan, multi-coloured jacket, and brightly patterned shirt screen-matching through their distinctive patterns. She wore her red jacket as they boarded the bus to Reykjavik and her scarf when she spoke to Lars (Will Ferrell) while he handed out fliers. The reddish cardigan is not obviously seen. Erick wore his cardigan when Lars and Sigrit were practising their music at the beginning of the film and it matches through the distinctive knit pattern. Several of the costume pieces are accompanied by production tags.

**Estimate: £1,500 - 3,000**

**1095**  
Production-Made Hand-Painted Bob Kayganich Canopy Matte Painting ◊  
**Evil Dead II (1987)**

A matte painting of a forest canopy hand-painted by matte painter Bob Kayganich for the production of Sam Raimi's Evil Dead II. Ash Williams (Bruce Campbell) was flung through the forest canopy while possessed by demons, only for them to be pushed out of his body by the daylight. Created for the film but ultimately unseen in the final cut, this matte painting of a forest canopy is rendered in mixed media on art board. The board exhibits some warping with stray paint marks along all four edges from production and handling. Dimensions: 87 cm x 71.25 cm (34.25" x 28") Sold without copyright; see copyright notice in the Buyer's Guide.

**Estimate: £800 - 1,600**

**1096**  
Martin Asbury Hand-drawn Production Storyboards for "Don't Cry For Me Argentina" Scene †  
**Evita (1996)**

A collection of Martin Asbury hand-drawn storyboards from Alan Parker's musical-historical film Evita. Asbury has storyboarded many high-profile films such as 'Labyrinth', 'Interview with the Vampire', 'Alien 3' and two of the Harry Potter features. The lot comprises 11 pages depicting the famous 'Don't Cry For Me Argentina' scene. The storyboards are rendered onto paper in pencil and ink and feature handwritten annotations. The shots differ slightly from those in the final cut. The pages exhibit some markings and minor discolouration. Dimensions: 30 cm x 21.5 cm x 1cm (11.75" x 8.5" x 0.5")

**Estimate: £1,500 - 3,000**

**1097**  
Terry English-made Miniature Merlin Helmet †  
**Excalibur (1981)**

A miniature Merlin (Nicol Williamson) helmet made by Terry English, armourer on the production of John Boorman's fantasy film Excalibur. Legendary movie armourer English created this miniature version of Merlin's helmet as a personal gift. It is made of aluminium. Dimensions: 13 cm x 10 cm x 10 cm (5" x 4" x 4")

**Estimate: £500 - 1,000**



**1098**  
Script Page with Scott Ridley Hand-Drawn "Ridleygram" Sketch †  
**Exodus: Gods And Kings (2014)**

A script page with a Ridleygram from the production of Ridley Scott's biblical epic Exodus: Gods and Kings. Ridleygrams are the nicknames for hurriedly drawn doodles and storyboards produced by Scott himself. The images are hand-drawn in black ink on script page 120, dated "27 Sept 13". The Ridleygrams are accompanied by handwritten annotations and notes. Dimensions: 29.5 cm x 21 cm (11.5" x 8.25")

**Estimate: £800 - 1,600**

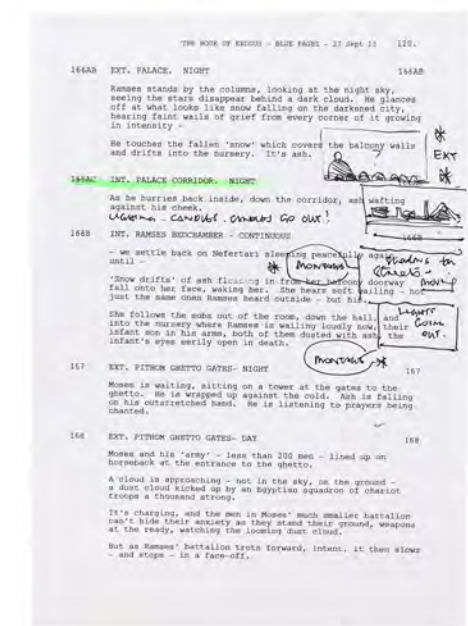

**1099**  
Gina's (Megan Fox) Stunt Heckler & Koch MP5K †  
**The Expendables 4 (2023)**

Gina's (Megan Fox) stunt Heckler & Koch MP5K from Scott Waugh's action sequel Expendables 4. Armed with her MP5K sub-machine gun, Gina and the other Expendables boarded Ocelot's ship that was transporting nuclear warheads in the Russian Far East. The gun is made from foam rubber, with details formed to replicate real MP5Ks accurately, including specifications engraved down the side. An armature runs through the centre of the gun to maintain its shape. The trigger exhibits a minor crack. Dimensions: 32 cm x 26 cm x 5 cm (12.5" x 10.25" x 2") Restricted ownership; see replica firearm notice in the Buyer's Guide.

**Estimate: £400 - 800**





**1100**  
Ritual Cloak †  
**Eyes Wide Shut (1999)**

A cloak from Stanley Kubrick's erotic mystery thriller *Eyes Wide Shut*. Dr William "Bill" Harford (Tom Cruise) infiltrated a ritualistic orgy party for the super elites, wearing a mask and a cloak just like the other attendees. So much is unique about the final feature film of arguably the most influential filmmaker in the history of cinema, Stanley Kubrick. Not least of which being that he passed away from a heart attack six days after the final cut was shown to Warner Bros. Kubrick himself called it his "greatest contribution to the art of cinema", and it topped the list as his highest-grossing film. The black cloak is made of polyester with a hood and lace adjustment feature at the collar's centre.

**Estimate: £1,000 - 2,000**



**1101**  
Castor Troy's (Nicolas Cage) Pair of Light-Up Magnetic Erewhon Prisoner Boots ♀  
**Face/Off (1997)**

Castor Troy's (Nicolas Cage) pair of light-up magnetic Erewhon prisoner boots from John Woo's *Face/Off*. In the guise of terrorist Troy, Archer and his fellow inmates at Erewhon Prison were fitted with magnetised boots designed to prevent a breakout. These heavyweight custom boots are constructed from black rubber and machined aluminium plating hand-marked "Cage" and "CR-10" on the interiors and engraved "ELWOOD SAFETY APPLIANCE CO." on both their heel plates. Plaques engraved with inmate number "75369-B," which differs slightly from Archer-as-Troy's inmate number as seen in the final cut, are screwed to their tops. The boots are inset with wiring and come with three electronic battery packs designed to illuminate the small round lights on the ankle cuffs, with the wiring recently having undergone restoration to restore functionality. The pair exhibits black stains, griminess to the rubber, scratching, and some rusting throughout from production wear and age. Contains electronics; see electronics notice in the Buyer's Guide.

**Estimate: £1,200 - 2,400**



**1102**  
UK Quad Poster and Lobby Cards ♀  
**Fantastic Voyage (1966)**

A UK Quad poster and lobby cards from the release of Richard Fleischer's sci-fi adventure film *Fantastic Voyage*. The lot comprises a UK Quad with artwork by Tom Beauvais and eight Front of House Lobby Cards featuring stills from the film. The poster has been roughly folded into sixteenths and has "Fantastic Voyage", "Fox" and "9" handwritten on the back. It has pin holes in each corner, evidence of sticky tack on the back and some creasing. Dimensions (poster): 75.5 cm x 101.5 cm (29.75" x 40")

**Estimate: £600 - 1,200**



**1103**  
Bathsheba Everdene's (Carey Mulligan) Screen-matched Bodice and Skirt †Δ  
**Far From The Madding Crowd (2015)**

Bathsheba Everdene's (Carey Mulligan) screen-matched bodice and skirt from Thomas Vinterberg's period drama *Far From the Madding Crowd*. Bathsheba wore her bodice and skirt when she set off to take over her uncle's farm, after inheriting the property from him. Both the bodice and skirt feature navy blue detailwork, including embroidery and pleating around the cuffs and hems. The bodice screen matches through the puckering of the stitching along its collar. Both the bodice and skirt feature an internal tag that reads "Sands Films". A belt, seen on screen, is not included in the lot.

**Estimate: £1,000 - 2,000**



**1104**  
Dominic Toretto's Stunt Sleeveless Shirt ♀  
**The Fast And The Furious (2001)**

Dominic Toretto's stunt sleeveless shirt from Rob Cohen's *The Fast and the Furious*. Dominic (Van Diesel) wore his shirt as he sat in the back room of his store, Toretto's Market & Cafe, where his sister Mia (Jordana Brewster) served Brian O'Conner (Paul Walker). This lot consists of a grey cotton sleeveless button-down shirt (Size XLM) labelled "DOM" and marked "STAND IN" with a Universal Studios production label. The shirt is intentionally distressed by production and exhibits fraying edges.

**Estimate: £2,500 - 5,000**



**1105**  
Hector's (Noel Gugliemi) Shirt and Jacket ♀  
**The Fast And The Furious (2001)**

Hector's (Noel Gugliemi) shirt and jacket from Rob Cohen's *The Fast and the Furious*. Hector wore his shirt and jacket as introduced himself to Brian O'Conner (Paul Walker) at a car meet while they waited for Dominic Toretto (Van Diesel). This lot consists of a white cotton Stafford shirt (Size 2XL) marked "HECTOR" and a brown cotton Jeans Wear corduroy jacket (Size XL) marked "Sc 93 Sc 39-43" and labelled "HECTOR." This lot exhibits a stain on the shirt's front.

**Estimate: £1,500 - 3,000**



**1106**  
 Letty's (Michelle Rodriguez) Snakeskin Blouse  
**The Fast And The Furious (2001)**

Letty's (Michelle Rodriguez) snakeskin blouse from Rob Cohen's The Fast and the Furious. Letty wore her shirt as she arrived at the car meet with Dominic Toretto (Vin Diesel) where they met Brian O'Conner (Paul Walker). This lot consists of a snakeskin print polyester mesh YAG shirt. The shirt exhibits minor discolouration.

**Estimate: £1,500 - 3,000**



**1107**  
 Dominic Toretto's (Vin Diesel) RX7 Passenger Seat with Nitrous Oxide Compartment  
**The Fast And The Furious (2001)**

Dominic Toretto's (Vin Diesel) RX7 passenger seat with nitrous oxide compartment from Rob Cohen's The Fast and the Furious. Though not seen directly in the film, Dom used his nitrous oxide cans in the film's initial race to keep Brian (Paul Walker) from surpassing him. This lot consists of one bucket seat with a hidden nitrous oxide compartment. Autographed on the backrest by Eddie Paul, who created custom vehicles for the film, in black ink with "FF 1 and 2", this seat is made of faux leather over dense foam, with a metal frame and features a removable faux-seat cushion made of rigid foam to reveal a compartment containing four dark blue canisters for NOS with two gauges and a textured yellow handle. The side of the seat has a motherboard interface with a toggle switch. One of the canisters features an additional autograph from Eddie Paul. This lot exhibits discolouration, tarnished metal, cracks, and a buildup of grime. Dimensions: 48.25 cm x 71.25 cm x 84 cm (19" x 28" x 33") Contains electronics; see electronics notice in the Buyer's Guide.

**Estimate: £1,500 - 3,000**



**1108**  
 Brian O'Connor's (Paul Walker) Supra Side Skirts  
**The Fast And The Furious (2001)**

Brian O'Connor's (Paul Walker) Supra side skirts from Rob Cohen's The Fast and the Furious. O'Connor drove his customised Toyota Supra while working undercover as part of a joint LAPD-FBI task force. This lot consists of two blaze orange fibreglass side skirts with black decals for various auto parts companies, handmarked on the inside with "638" and "640" respectively. Both skirts exhibit scuffing and paint chipping throughout. Dimensions: (each) 199.5 cm x 44.5 cm x 15.25 cm (78.5" x 17.5" x 6") Special shipping required; see notice in the Buyer's Guide.

**Estimate: £1,500 - 3,000**

**1109**  
 Dominic Toretto's (Vin Diesel) Stunt Shotgun and Letty Ortiz's (Michelle Rodriguez) Stunt Pistol  
**Fast & Furious 9 (2021)**

Dominic Toretto's (Vin Diesel) stunt shotgun and Letty Ortiz's (Michelle Rodriguez) stunt pistol from Justin Lin's action sequel Fast & Furious 9. Dom and Letty fought their way out of trouble with their guns when ambushed in the fictional Central American country Montequinto by Jakob's (John Cena) private army. Dom's shotgun is a Mossberg 590 Mariner 12 gauge with a pistol grip/stock combination. Five faux shotgun cartridges are stored at the right rear side of the gun. Letty's pistol is a semi-automatic Beretta 9000s. Both guns have been painted to look like metal and feature armatures running through their bodies to maintain shape. Dimensions: 97 cm x 16 cm x 7 cm (38.25" x 6.25" x 2.75") Restricted ownership; see replica firearm notice in the Buyer's Guide.



**Estimate: £2,500 - 5,000**

**1110**  
 Hattie Shaw's (Vanessa Kirby) Stunt Virus Extraction Device  
**Fast & Furious Presents: Hobbs & Shaw (2019)**

Hattie Shaw's (Vanessa Kirby) stunt virus extraction device from David Leitch's action comedy Fast & Furious Presents: Hobbs & Shaw. MI6 agent Hattie Shaw used a specially designed device to extract the Snowflake supervirus from her system. It bears a sticker that mimics a screen, declaring the transfer of the virus "00:19:52" minutes into completion. The device is made of foam rubber and silicone, and painted to look like metal, with silicone tubing that still holds some stage blood. Dimensions: 65 cm x 30 cm x 10 cm (26" x 12" x 4")



**Estimate: £600 - 1,200**

**1111**  
 'Madame M' (Eiza Gonzalez) Stunt Beretta 92FS Custom Nickel Pistol  
**Fast & Furious Presents: Hobbs & Shaw (2019)**

'Madame M' (Eiza Gonzalez) stunt Beretta 92FS pistol from David Leitch's 2019 action spin-off Fast & Furious Presents: Hobbs & Shaw. M carried her pistol as she provided Hobbs (Dwayne Johnson), Shaw (Jason Statham) and Hattie (Vanessa Kirby) with information and equipment for infiltrating Brixton Lore's (Idris Elba) hideout. The foam rubber stunt pistol features a gold-coloured grip inlaid with faux diamonds. The paint has become discoloured in several places along the weapon. Dimensions: 21.5 cm x 4 cm x 14 cm (8.5" x 1.5" x 5.5") Restricted ownership; see replica firearm notice in the Buyer's Guide.



**Estimate: £400 - 800**



**1112**  
Jakob's (John Cena) Stunt  
SilencerCo Maxim 9 †Δ  
**Fast X (2023)**

Jakob's (John Cena) stunt SilencerCo Maxim 9 from Louis Leterrier and Justin Lin's action adventure sequel Fast X. Jakob fought off agency operatives with his SilencerCo Maxim 9. The gun has accurate details and designs engraved into its foam rubber material, such as the specification. An armature runs through the gun to maintain its shape. Dimensions: 27 cm x 14.5 cm x 3.5 cm (10.75" x 5.75" x 1.5") Restricted ownership; see replica firearm notice in the Buyer's Guide.

**Estimate: £400 - 800**



**1113**  
Cast-Autographed Photo M  
**Fawlty Towers (T.V. Series,  
1975-1979)**

A cast-autographed photograph from the iconic British 1970s sitcom Fawlty Towers. The photograph has been autographed by John Cleese (Basil Fawlty and writer), Connie Booth (Polly Sherman and writer), Prunella Scales (Sybil Fawlty) and Andrew Sachs (Manuel), in various ink colours, beside their respective characters. Dimensions: 25.5 cm x 20.5 cm (10" x 8") The autographs in this lot have been professionally authenticated by expert Garry King; see notice in the Buyer's Guide.

**Estimate: £800 - 1,600**



**1114**  
Disembowelled Baby Monster †Δ  
**Feast (2005)**

A disembowelled baby monster from John Gulager's horror-comedy Feast. The bar's patrons shot the baby monster dead while it was contained in an ice chest before handing it back to the adult monsters in an attempt to deter them from further attacks. This disembowelled baby is made of foam latex. Dimensions: 90 cm x 37 cm x 15 cm (35.5" x 14.5" x 6")

**Estimate: £1,000 - 2,000**

**1115**  
Production Clapperboard and  
Photographs M  
**The Fifth Element (1997)**

A production clapperboard and photos from Luc Besson's sci-fi The Fifth Element.

The clapperboard features the exact day of filming it was last used for as "27.2.96". Both the names of Director Luc Besson and Director of Photography Thierry Arbogast are carved into the acrylic slate and a piece of tape with "5293" handwritten on it is adhered to the back. The 14 black-and-white photos depict actors, such as Bruce Willis, in character, out of character, and other crew members on set. One of the photographs has handwritten annotations in its borders. Dimensions: 28.25 cm x 25 cm x 2.5 cm (11" x 9.75" x 1")

**Estimate: £3,000 - 6,000**

**1116**  
General Munro's (Brion James) Multi Pass †Δ  
**The Fifth Element (1997)**

General Munro's (Brion James) multi pass from Luc Besson's sci-fi action film The Fifth Element. Characters used their multi passes as a form of identification and Munro used his to begin the process of bringing Leeloo (Milla Jovovich) to life. The pass features a graphic with Munro's image and details adhered to a plastic card. There is a piece of acrylic adhered to the back with tape. The pass has been removed from its grey casing seen in the film, and the graphic has started to peel away at the edges. Dimensions: 7.5 cm x 5 cm x 0.5 cm (3" x 2" x 0.25")

**Estimate: £500 - 1,000**

**1117**  
Mangalore Hands and Costume  
Components with Police Costume  
Components M  
**The Fifth Element (1997)**

A pair of Mangalore hands and costume components with police costume components from Luc Besson's sci-fi The Fifth Element. Mangalores pursued Leeloo (Milla Jovovich) and Korben Dallas (Bruce Willis) in search of the Mondoshawan elemental stones. Police officers appeared throughout the film. The hands are made of foam rubber, filled with removable foam to maintain their shape and enable them to be displayed on their individual resin-based stands. "A" has been handwritten in marker pen on the wrist of the right hand. The other Mangalore components include a foam rubber chest piece and a set of suede cords. The police costume components are one armour mechanism made of vac-formed plastic, rubber, and metal and plastic tubes; one vac-formed plastic armour shoulder plate with an inoperative light; two acrylic helmet panels; and three foam board badges. The lot also includes one translucent set design piece and three vac-formed plastic armour plates. Dimensions (one hand displayed): 35 cm x 17 cm x 34.5 cm (13.75" x 6.75" x 13.5") Contains electronics; see electronics notice in the Buyer's Guide.

**Estimate: £1,000 - 2,000**





**1118**  
Korben Dallas' (Bruce Willis) Stunt Trophy  $\Omega$   
**The Fifth Element (1997)**

Korben Dallas' (Bruce Willis) stunt trophy from Luc Besson's sci-fi adventure *The Fifth Element*. The former Special Forces soldier displayed his awards in his apartment. In an attempt to prevent Dallas from travelling to Fhloston Paradise, Father Cornelius (Ian Holm) used a trophy to knock Dallas unconscious. The brown and gold-colour painted trophy is made of foam with a support running through the middle. It features a circular headpiece with a cross and eagle emblem in the centre and Dallas' name printed across the front of the base. The piece exhibits production use throughout, including worn paint and creases in the foam. Dimensions: 12.5 cm x 8 cm x 30 cm (5" x 3" x 12")

**Estimate: £2,000 - 4,000**



**1119**  
The Narrator's (Edward Norton) Grey Suit  $\Omega$   
**Fight Club (1999)**

The Narrator's (Edward Norton) grey suit from David Fincher's *Fight Club*. The Narrator wore his grey suit throughout the film along with a penguin-patterned necktie as he travelled for work. This costume consists of a grey cotton and polyester suit jacket from Brooks Brothers, a white cotton button-up shirt from Nordstroms (Size 15 1/2 - 34), a grey silk necktie with a repeating pattern of a small penguin graphic along with white and red striping from Anto, and a pair of matching grey cotton and polyester trousers. Production intentionally distressed the shirt to appear grimy. This lot exhibits discolouration.

**Estimate: £2,000 - 4,000**



**1121**  
Pair of Tyler Durden's (Brad Pitt) Boarding Passes  $\Omega$   
**Fight Club (1999)**

A pair of Tyler Durden's (Brad Pitt) boarding passes from David Fincher's *Fight Club*. The Narrator (Edward Norton) stumbled across multiple boarding passes while rummaging through Durden's belongings.

This lot consists of two custom-made, serrated boarding passes, one for an "Access Airlines" flight from "Bradford" to "Phoenix" and one for an "Escort Air" flight from "Bradford" to "Salt Lake City." Both are made out to "Durden/Tyler" and feature matching document numbers "00051331653891." The passes exhibit fading on the back and discolouration. Dimensions: (each) 20.5 cm x 7.75 cm (8" x 3")

**Estimate: £1,200 - 2,400**



**1122**  
The Narrator's (Edward Norton) Grey Dress Shirt and Tie  $\Omega$   
**Fight Club (1999)**

The Narrator's (Edward Norton) grey dress shirt and tie from David Fincher's *Fight Club*. The Narrator wore his shirt and tie during a testicular cancer support group meeting where he hugged and cried against Robert "Bob" Paulson (Meat Loaf). This lot consists of a light blue polyester-cotton Pierre Cardin long-sleeve, button-down shirt (Size 15 1/2 34/35); and a black and grey motif polyester Mulberry tie. This lot exhibits minor stains to the shirt collar.

**Estimate: £800 - 1,600**



**1120**  
The Narrator's (Edward Norton) Dark Navy Jacket  $\Omega$   
**Fight Club (1999)**

The Narrator's (Edward Norton) dark navy jacket from David Fincher's *Fight Club*. The Narrator wore an assortment of jackets throughout the film, such as a zip-up jacket when Marla (Helena Bonham Carter) called him after taking a large amount of pills, and then later while he and Tyler (Brad Pitt) held up a liquor store clerk. This lot consists of a polyester- and cotton-blend zip-up jacket from Dickies (Size L). The interior tag is hand-marked with illegible writing in black ink. Also included is a production tag hand-marked for sheet "5335" for lines "1-13, 15, 16" and an additional note for "Hold - Line 15." This lot exhibits some creasing to the tag.

**Estimate: £1,500 - 3,000**



**1123**  
King Arthur's (Sean Connery) Sword  $\dagger$   
**First Knight (1995)**

King Arthur's (Sean Connery) sword from Jerry Zucker's action drama *First Knight*. King Arthur wore his sword sheathed on his belt during scenes where he met his knights at the round table, and fought with it in the final battle at the film's end. The blade is made of aluminium, while the hilt and handle are made of steel, with a leather grip and a rounded pommel featuring a blue enamel cross and gold-coloured crown. King Arthur was the only character to carry a sword with a blue enamel cross. The sword exhibits minor rusting to parts of its blade. Dimensions (sword in scabbard): 107 cm x 19.75 cm x 4 cm (42.25" x 7.75" x 1.5") Edged, bladed or blunt object; see notice on Blades in the Buyer's Guide.

**Estimate: £4,000 - 8,000**



**1124**  
The Costumi d'Arte Collection:  
Lancelot's (Richard Gere) Knights of  
the Round Table Costume  $\Omega$   
**First Knight (1995)**

Lancelot's (Richard Gere) Knights of the Round Table costume from Jerry Zucker's adventure-drama film First Knight. Lancelot wore his blue medieval uniform throughout Camelot and during the final battle against Malagant's (Ben Cross) forces. This lot comes from the archives of the Italian costume company Costumi d'Arte. The costume comprises a tunic, a protective tabard, trousers and a pauldron. The tunic is predominantly cotton, with the upper sleeves corduroy and the sections at the shoulders made of velvet. The tabard is made of cotton corduroy and faux suede, embellished with metal studs. The trousers are grey cotton, while the pauldron is made of fibreglass, finished to look like steel. A metal hook fitted to the inside of the pauldron allows it to be attached to the tabard by a leather strap on the left shoulder. The tunic, tabard and trousers all feature labels with "Lancelot" and "Richard Gere" handwritten on them in black marker pen. The trousers also have a "1" handwritten on the same label.

**Estimate: £1,000 - 2,000**

**1125**  
The Costumi d'Arte Collection:  
King Arthur's (Sean Connery)  
Welcoming Ceremony Costume  $\Omega$   
**First Knight (1995)**

King Arthur's (Sean Connery) welcoming ceremony costume from Jerry Zucker's action drama First Knight. King Arthur wore a blue medieval outfit as he welcomed his wife-to-be Guinevere (Julia Ormond) to Camelot. This lot comes from the archives of the Italian costume company Costumi d'Arte. The costume comprises a tunic with a matching hood, a tabard, and a pair of trousers. The tunic has a velvet upper torso and sleeves, with the remaining outer surface made from polyester, and the inner lining made from nylon. "King Arthur - Sean Connery" is handwritten in black marker pen on the tunic's label. The tabard is made of a synthetic blended fabric with a nylon inner lining and features "King Arthur - Sean Connery" handwritten on a label in black marker. The trousers are unsized and made of velvet with a nylon inner lining. They are Velcro adjusted and feature a label in the waist that reads "King Arthur 1 - Sean Connery".

**Estimate: £2,000 - 4,000**



**1126**  
Clapperboard  $\Omega$   
**A Fish Called Wanda (1988)**

A clapperboard from the production of Charles Crichton's crime comedy A Fish Called Wanda. This wooden clapperboard has been painted primarily black with a black-and-white chevron pattern applied over one side of the clapper. The production name, and the names of the Crichton, uncredited co-director John Cleese, and cinematographer Alan Hume have been hand-painted on the board in white. A strip of beige tape is adhered along the bottom edge and display the date of its last use, "10.2.88 EXTERIOR - DAY" written in black marker pen. This tape is held on with sticky tack and covers another piece of tape which reads "9-2-88 INTERIOR NIGHT".  
Dimensions: 30 cm x 38 cm x 1.5 cm (11.75" x 15" x 0.5")

**Estimate: £800 - 1,600**



**1127**  
Palace Guard Skull Mask and  
Hawkman Bomb  $\Omega$   
**Flash Gordon (1980)**

A palace guard skull mask and a Hawkman bomb from Mike Hodges' sci-fi adventure Flash Gordon. Emperor Ming the Merciless' (Max von Sydow) palace guards wore skull masks throughout the film, and bombs were used by the Hawkmen and Flash (Sam J. Jones) when they infiltrated the War Rocket Ajax. The gold-coloured fibreglass mask is finished with black paint in the eye sockets and nostrils to add dimension, while the bomb, made of the same material, features metal mesh detailing and a handle at the top. The gold finish on both pieces displays signs of wear, with notable fading on the bomb and rusting on the mesh. The grenade is accompanied by a certificate of authenticity from Walt Disney Attractions, Inc. Dimensions (mask): 15.5 cm x 14 cm x 9.5 cm (6.25" x 5.5" x 3.75"); (bomb): 15 cm x 10 cm x 10 cm (6" x 4" x 4")

**Estimate: £1,500 - 3,000**

**1128**  
Hero Ming Guard Sword  $\Omega$   
**Flash Gordon (1980)**

A hero Ming guard sword from Mike Hodges' sci-fi adventure Flash Gordon. When Flash Gordon (Sam J. Jones) teamed up with Prince Vultan (Brian Blessed) and his army of winged hawkmen in an attack on the flagship of Ming's (Max Von Sydow) fleet, his guards repelled them with both blasters and swords.

This goldtone metal sword exhibits scuffs on the handle and blade from production use. It also exhibits a minor rust on one side of the sword's tip.  
Dimensions: 84 cm x 8.5 cm x 2.75 cm (33" x 3.25" x 1")

Edged, bladed or blunt object; see notice on Blades in the Buyer's Guide.

**Estimate: £1,000 - 2,000**

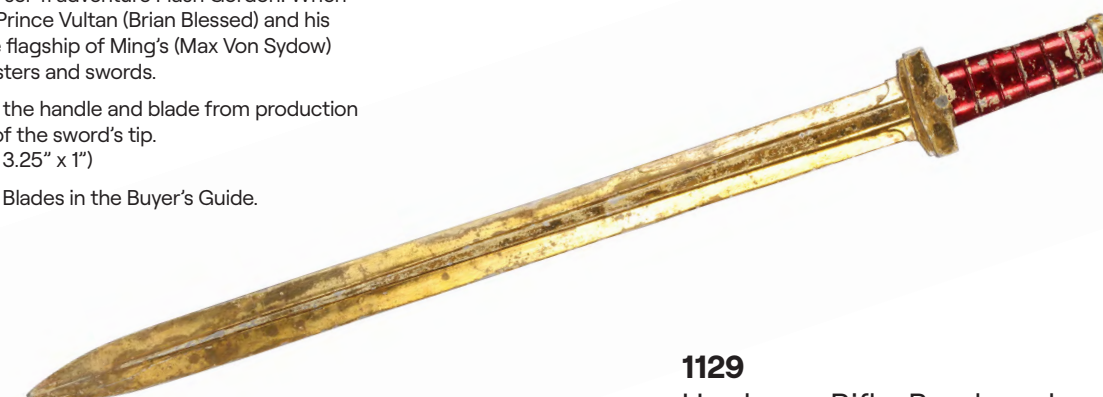

**1129**  
Hawkman Rifle, Bomb and  
Tree People Knife  $\Omega$   
**Flash Gordon (1980)**

A Hawkman rifle and bomb with a Tree Person's knife from Mike Hodges' adventure sci-fi Flash Gordon. Flash Gordon (Sam J. Jones), Prince Vultan (Brian Blessed), and his fellow Hawkman fought against Ming's (Max von Sydow) forces with rifles and bombs. The Tree People, commanded by Prince Barin (Timothy Dalton), wielded knives.

The rifle is made from fibreglass, as is the bomb which also features metal components. Both the knife's handle and blade are also made from fibreglass, while its accompanying green sheath is faux leather.

They all exhibit an amount of chipping to their paintwork. Specifically, the bomb exhibits rusting while the end of the knife's blade is missing.  
Dimensions: 72 cm x 23.5 cm x 8.25 cm (28.25" x 9.25" x 3.25")

Edged, bladed or blunt object; see notice on Blades in the Buyer's Guide.

**Estimate: £2,500 - 5,000**





**1130**  
Ming Palace Guard Helmet and Skull Mask m  
**Flash Gordon (1980)**

A Ming Palace Guard Helmet and Skull Mask from Mike Hodges' sci-fi adventure Flash Gordon. Helmets were worn by the guards operating the weapons batteries of Mongo's imperial palace. Emperor Ming's (Max von Sydow) guards wore their masks when Flash Gordon (Sam J. Jones) and his companions first entered the palace, and later when the Hawkmen attacked the War Rocket Ajax.

The helmet is made of fibreglass and is painted glossy black with gold-coloured embellishments and a red star emblem. The gold-coloured mask is also fibreglass, finished with black paint in the eye sockets and nostrils to add definition to the features.

Both items exhibit minor chipping to their surfaces, while the mask is missing its elasticated strap. Dimensions (helmet): 24 cm x 17 cm x 21.75 cm (9.5" x 6.75" x 8.5")



**Estimate: £2,000 - 4,000**



**1131**  
Chris Foss Hand-drawn and Painted Concept Drawings  
for Flash's Rocket Cycle m  
**Flash Gordon (1980)**

A collection of concept drawings for Flash's rocket cycle from the production of Mike Hodges' space superhero film Flash Gordon. Flash (Sam J. Jones) used a rocket cycle to travel around, including when he escaped Sky City as it exploded around him. The lot includes five pages with hand-drawn concept art in various stages. Three pages feature rough sketches and two pages feature more detailed, hand-coloured images. These images are labelled "Sheet No 4" and "Sheet No 5". No 4 is also labelled "Design for Flash Gordon's Rocket Scooter from Chris Foss" and "This One". The pages have some minor staining. Dimensions (largest page): 25 cm x 35 cm (9.75" x 13.75") Sold without copyright; see copyright notice in the Buyer's Guide.

**Estimate: £2,000 - 4,000**

**1132**  
Ming's (Max Von Sydow) Soldier's  
Sword n  
**Flash Gordon (1980)**

A Ming guard's sword from Mike Hodges' Flash Gordon. Guards protecting Ming the Merciless (Max von Sydow) wielded their swords when they captured Flash Gordon (Sam J. Jones). Gordon later used one of their swords to break up Ming's wedding, and wielded a similar style of sword on the film's theatrical poster. This fibreglass and resin sword features a curved blade with a decorative star-shaped engraving at centre and a shiny gold-colour finish, as well as a matching pommel and plated crimson grip. The sword exhibits extensive paint flaking, with half the star engraving peeled off from use and age. Dimensions: 119.5 cm x 20.25 cm x 7.75 cm (47" x 8" x 3") Edged, bladed or blunt object; see notice on Blades in the Buyer's Guide.



**Estimate: £1,500 - 3,000**

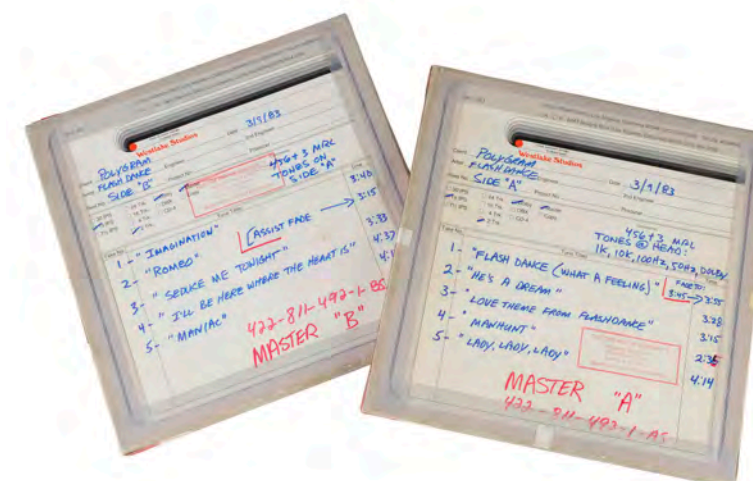

**1133**  
Master Side A and Master Side B Tapes n  
**Flashdance (1983)**

Master Side A and master Side B tapes from Adrian Lyne's Flashdance. Welder and nightly exotic dancer Alexandra Owens (Jennifer Beals) aspired to be a ballet dancer despite her lack of formal dance training. This lot consists of two metal Ampex film reels, one labelled "SIDE A" and one labelled "SIDE B," each in a corresponding Ampex storage box. Side A box is marked "Polygram" and "Master A" dated March 9, 1983 featuring the songs "Flash dance (What A Feeling)," "He's A Dream," "Love Theme From Flashdance," "Manhunt," and "Lady, Lady, Lady." Side B box features the same markings and "Master B" as well as the songs "Imagination," "Romeo," "Seduce Me Tonight," "I'll Be Here Where The Heart Is," and "Maniac." This lot exhibits discolouration to the boxes. Dimensions: (each) 28 cm x 28 cm x 2 cm (11" x 11" x 0.75")

**Estimate: £500 - 1,000**

**1134**  
Trimaxion Drone Door n  
**Flight Of The Navigator (1986)**

A Trimaxion drone door from Randal Kleiser's sci-fi adventure film Flight of the Navigator. While 12-year-old David Freeman (Joey Cramer) piloted the alien spacecraft, a Trimaxion drone, a silver door could be seen behind him, integrated with the ship's surrounding interior. Made from high-density vac-formed polycarbonate, the door displays protruding symbols that match the rest of the ship's sleek, futuristic design. These patterned sequences of symbols and shapes were created through the process of vacuum forming and then painted silver to give the appearance of a chrome finish. Dimensions: 114 cm x 105 cm x 4 cm (45" x 41.25" x 1.5")

**Estimate: £2,000 - 4,000**



114 cm  
(45")



**1135**  
Pair of Flintstones Dinosaur Maquettes m  
**The Flintstones (1994)**

Two dinosaur maquettes from the production of Brian Levant's family comedy film The Flintstones. Maquettes were supplied for the film by Jim Henson's Creature Shop and were used by the visual effects department as master reference for colour matching and CGI modelling. The set comprises a red hedgehog-like creature climbing a tree stump on a black wooden base, and an ankylosaurus, which Fred Flintstone (John Goodman) uses as a beard trimmer. Made of cast resin and expertly painted, the maquettes exhibit highly intricate detailing and texturing, and the ankylosaurus features acrylic eyes. Dimensions (hedgehog): 25 cm x 24 cm x 20 cm (10" x 9" x 8")

**Estimate: £1,500 - 3,000**



**1136**  
 Captain Daniel McCormick's (Mel Gibson)  
 Screen-matched Flight Jacket and Sneakers  $\Omega$   
**Forever Young (1992)**

Captain Daniel McCormick's (Mel Gibson) screen-matched aviator jacket and sneakers from Steve Miner's *Forever Young*. After being unfrozen in 1992, WWII-era test pilot McCormick obtained modern sneakers and was later given a new flight jacket by Nat Cooper (Elijah Wood) so he could teach Cooper how to fly. Distinctive wear in the embroidery of the jacket's patch screen-match to shots throughout the film. This lot consists of a green nylon Avirex B-15 flight jacket (Size L) marked "Mel #1," with a brown faux fur collar, polyester-filled acetate lining, and a cotton pilot's patch embroidered on the left sleeve, as well as a pair of white Reebok Pump basketball sneakers handmarked "11 1/2." The jacket exhibits minor discoloration and the sneakers exhibit scuffing, dirt stains, and minor loss of small pieces from age and wear.

**Estimate: £1,500 - 3,000**

**1137**  
 Charles' (Hugh Grant) Glasses  $\mathcal{M}$   
**Four Weddings And A Funeral (1994)**

Charles' (Hugh Grant) glasses from Mike Newell's romantic comedy *Four Weddings and a Funeral*. Charles wore his glasses when he attended the film's four weddings. The glasses comprise a plastic frame connected by metal hinge joints. Dimensions: 12.5 cm x 13.25 cm x 4.25 cm (5" x 5.25" x 1.75")

**Estimate: £1,000 - 2,000**



**1138**  
 Revised Script and Production Paperwork  $\mathcal{M}$   
**Frankenstein And The Monster From Hell (1974)**

A revised script and paperwork from the production of Terence Fisher's British horror film *Frankenstein and the Monster From Hell*.

The 122-page script features several revised pages printed on pink, blue, orange and yellow paper. Assistant director Derek Whitehurst's name and issue number "20" are handwritten on the title page. "Frankenstein & Monster From Hell" is handwritten in blue marker along the spine, and the document features annotations throughout.

The production paperwork comprises film negatives, a cast list, special effects meeting notes, a unit list, 31 printed copies of artist contracts, and a Hammer Film Productions Ltd memo addressed to Peter Cushing, who played Baron Frankenstein. The lot displays signs of age and wear, including minor discoloration and small tears to the page edges, while some pages have become folded over time.

Dimensions (script): 29 cm x 23.5 cm x 2 cm (11.5" x 9.25" x 0.75")

**Estimate: £1,000 - 2,000**

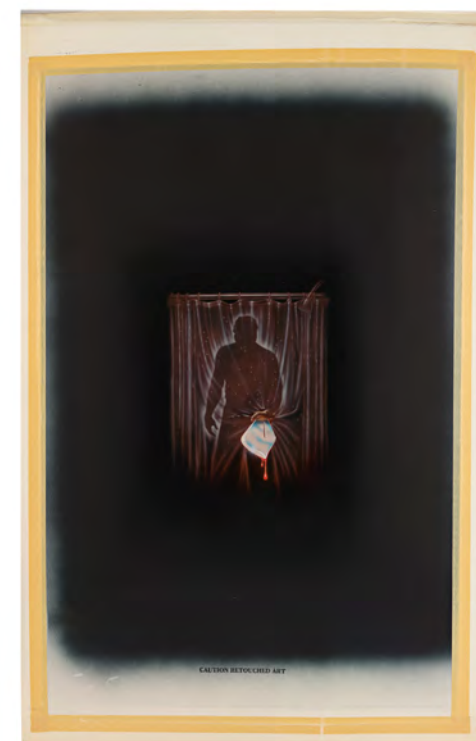

**1139**  
 Original Hand-painted Paramount VHS Box Art  $\Omega$   
**Friday The 13th Part III (1982)**

A piece of original hand-painted artwork for Paramount's VHS boxes used to distribute Steve Miner's slasher sequel *Friday the 13th Part III*. Rendered on a large piece of card by an airbrush, the artwork depicts the same iconic design used for the film's poster: Jason Voorhees (Richard Brooker) stabbing through a shower curtain with a blood-dripping knife. Paramount then used this artwork as the cover art for their VHS release of the film. Two overlays, one acetate and the other paper, protect the artwork. The overlays can be removed. Dimensions: 76.5 cm x 51 cm (30" x 20") Sold without copyright; see copyright notice in the Buyer's Guide.

**Estimate: £1,000 - 2,000**



**1140**  
 Hand-painted Hockey Mask Production Artwork  $\Omega$   
**Friday The 13th Part VII: The New Blood (1988)**

A piece of hand-painted hockey mask production artwork from John Carl Buechler's slasher sequel *Friday the 13th Part VII: The New Blood*. Rendered on a piece of off-white paper, the artwork depicts the infamous blood-splattered hockey mask worn by Jason Voorhees (Kane Hodder) in the film. The piece was originally used for part six in the franchise to make a mask and axe that hung from a ceiling. It was later reused in part seven to produce die-cut cardboard hockey masks as promotional items that accompanied VHS purchases of the movie from video stores. Dimensions: 46.25 cm x 35.5 cm (18.25" x 14") Sold without copyright; see copyright notice in the Buyer's Guide.

**Estimate: £2,000 - 4,000**

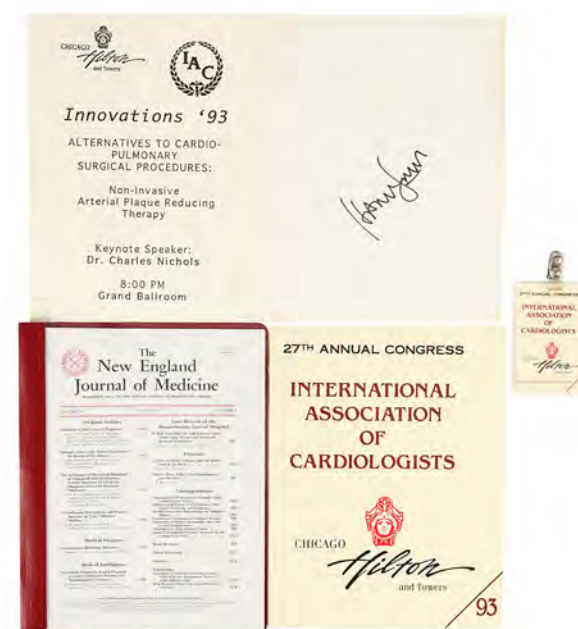

**1141**  
 Harrison Ford Autograph, Journal of  
 Medicine and Hilton Paperwork  $\Omega$   
**The Fugitive (1993)**

A Harrison Ford autograph and prop paperwork from Andrew Davis's thriller *The Fugitive*. The paperwork is from the climactic scene at the International Association of Cardiologists congress when Dr. Richard Kimble (Harrison Ford) confronted Dr. Charles Nichols (Jeroen Krabbe) over his role in Kimble's wife's death. The autograph was acquired during filming at the Chicago Hilton in 1993, and the paperwork relates to the event itself, including a laminated badge worn by attendees. The folders in the collection are padded with blank pages. Dimensions (folder): 29 cm x 23 cm (11.5" x 9") The autographs in this lot have been professionally authenticated by expert Garry King; see notice in the Buyer's Guide.

**Estimate: £600 - 1,200**



**1142**  
Gerald's (Tom Wilkinson) Red  
Leather Thong M  
**The Full Monty (1997)**

Gerald's (Tom Wilkinson) red leather thong from Peter Cattaneo's comedy film *The Full Monty*. Gerald wore his thong while performing his striptease act. The thong is made of real leather, lined with suede, and has an elasticated waist, which attaches at either side with hook and loop fastening, to facilitate the part of the performance during which Gerald tore his thong off. The thong has been autographed by Wilkinson in black ink over the crotch, and handwritten onto the label is "Gerald 38". The thong also comes with a certificate of authenticity signed by Wilkinson himself. The autographs in this lot have been professionally authenticated by expert Garry King; see notice in the Buyer's Guide.

**Estimate: £1,000 - 2,000**



**1145**  
Davos Seaworth's (Liam Cunningham) Gloves †  
**Game Of Thrones (T.V. Series, 2011-2019)**

Davos Seaworth's (Liam Cunningham) gloves from the fantasy TV series *Game of Thrones*. Davos wore his gloves throughout the series, while serving Stannis Baratheon (Stephen Dillane) and later Daenerys Targaryen (Emilia Clarke). The gloves are made of dark brown leather, and notably neither features altered fingers, though Davos was missing the last knuckle of each finger, having had them removed by Stannis as punishment for smuggling. Included with the lot is a photo of Cunningham as Davos wearing the gloves, autographed by the actor, as well as a certificate of authenticity. The left glove exhibits some seam ripping.

**Estimate: £1,000 - 2,000**



**1143**  
Bolton Family Banner M  
**Game Of Thrones**  
**(T.V. Series, 2011-2019)**

A Bolton family banner from the multi-E Emmy-award-winning fantasy TV show *Game of Thrones*. Throughout the series, Bolton family banners of varying sizes were seen amongst battlefields, castles, and camps. This cloth banner is silkscreen printed with the family's coat of arms, which is that of a flayed man hanging upside down on a cross. This is a brutally honest symbolisation of the depraved and twisted nature of House Bolton, whose most prominent members, Ramsay Bolton (Iwan Rheon) and Roose Bolton (Michael McElhatton), were known for committing some of the most inhumane and barbaric acts in Westeros. Dimensions: 94 cm x 31 cm (37" x 12.25")

**Estimate:**  
**£1,000 - 2,000**



**1144**  
Dothraki SFX Sword †Δ  
**Game Of Thrones -**  
**The Long Night (2019)**

A Dothraki SFX sword from HBO's multi-E Emmy-Award-winning fantasy TV show *Game of Thrones*. In the Season 8 episode "The Long Night", Melisandre (Carice van Houten) enchanted the Dothrakis' weapons to become wreathed in flame before they charged the Army of the Dead during the Battle of Winterfell. This arakh sword features the SFX mechanism used to set the swords alight during filming. A gas canister located behind the resin handle would have been filled via a valve at the bottom of the hilt, while two narrow channels within both edges of the aluminium blade stored liquid fuel. The flick switch on the handle then activated the sword, meaning that once its ignition button was pressed, two fuses at the bottom of the blade lit the fuel stored in the channels, causing the sword to burst into flame. The arakh has been rendered inoperable, and has some paint wear from production use. Dimensions: 101 cm x 26 cm x 7 cm (39.75" x 10.25" x 2.75") Contains electronics; see electronics notice in the Buyer's Guide. Contains mechanical components; see mechanical notice in the Buyer's Guide. Edged, bladed or blunt object; see notice on Blades in the Buyer's Guide.

**Estimate: £2,000 - 4,000**

**1146**  
Amsterdam Vallon's (Leonardo DiCaprio)  
Photo-matched Waistcoat M  
**Gangs Of New York (2002)**

Amsterdam Vallon's (Leonardo DiCaprio) photo-matched waistcoat from Martin Scorsese's historical epic *Gangs of New York*. Amsterdam wore his waistcoat while he stood on the docks with William "Bill the Butcher" Cutting (Daniel Day-Lewis) and William "Boss" Tweed (Jim Broadbent), watching newly arrived immigrants be enrolled into the Union army. It photo-matches to a promotional image of DiCaprio in his costume. The velvet waistcoat features a check pattern and an interior label by the left armpit reads "Bill the Butcher".

**Estimate: £1,500 - 3,000**



**1147**  
UK Quad Poster †  
**Get Carter (1971)**

A linen-backed UK Quad poster from the release of Mike Hodges' gangster film *Get Carter*. Designed by Italian artist Arnaldo Putzu, the poster blends elements of 1960s psychedelia and British gangster motifs, suggesting the "flower-power" of the 60s is very much gone, to be replaced by the harsh and violent realities of the 1970s. The linen-backed poster has been minimally touched up along the fold-lines and pinholes in each corner and remains in a very fine condition. Dimensions: 76 cm x 101 cm (30" x 40")

**Estimate: £3,000 - 6,000**



**1148**  
Major's Section 9 Tactical Uniform  
Costume  $\Omega$   
**Ghost In The Shell (2017)**

Major's Section 9 tactical uniform costume from Rupert Sanders' Ghost in the Shell. Major (Scarlett Johansson) wore her Section 9 tactical uniform while she fought the spider tank. This costume consists of grey nylon and foam armour vest marked for Major with "Stunt" featuring fastening strip closures; a grey nylon and cotton jacket marked for Major with "Hero" featuring fastening strip closures; a pair of matching trousers marked for Major with "Body Double" with attached grieves; and a pair of nylon, rubber, and polyester boots with fastening strip closures marked for "Carly." Also included are four paper production tags with costume information. The vest was intentionally distressed by production with burn marks and holes, while the rest of the costume exhibits some minor staining from use.

**Estimate: £2,000 - 4,000**

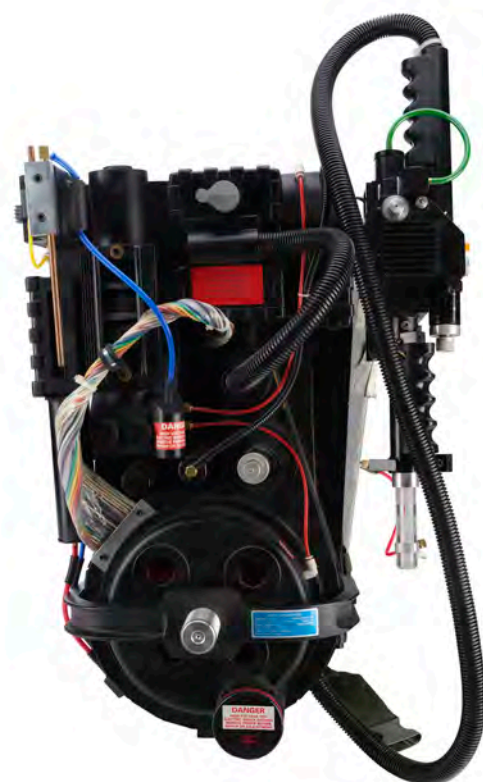

**1149**  
Light-Up Proton Pack Replica  $\Omega$   
**Ghostbusters (1984)**

A light-up proton pack replica from Ivan Reitman's Ghostbusters. Peter Venkman (Bill Murray), Ray Stantz (Dan Aykroyd), Egon Spangler (Harold Ramis) and Winston Zeddemore (Ernie Hudson) used their particle accelerating proton packs to weaken and trap ghosts while working as paranormal investigators. This lot consists of a proton pack composed of plastic with metal components, a metal ALICE pack frame with a foam bumper mounted on back, and an attached plastic replica Neutrino wand with toggleable switches, buttons, and knobs. The pack features various sticker decals pertaining to warnings, cautions, and danger all throughout. It has olive green webbed nylon padded straps. This pack was intentionally distressed to appear used. This lot exhibits a mild buildup of grime, dents, scuffing, chipped paint on the wand, and mild discoloration on the wires. Dimensions: 91.5 cm x 43.25 cm x 31.75 cm (36" x 17" x 12.5") Contains electronics; see electronics notice in the Buyer's Guide.

**Estimate: £4,000 - 8,000**



**1150**  
Ectomobile Decal  $M$   
**Ghostbusters II (1989)**

An Ectomobile decal from Ivan Reitman's action-comedy sequel Ghostbusters II. Decals depicting the iconic No-Ghost logo were seen on each side of the Ghostbusters' car throughout the film. This updated version shows the ghost holding up two fingers. Dimensions: 56.5 cm x 44 cm (22.25" x 17.25")

**Estimate: £1,000 - 2,000**

**1151**  
Production-Made Nunzio Scoleri (Tim  
Lawrence) Head Casting  $\Omega$   
**Ghostbusters II (1989)**

A production-made Nunzio Scoleri (Tim Lawrence) head casting from Ivan Reitman's Ghostbusters II. Negatively-charged slime in the courtroom where the Ghostbusters were on trial manifested the ghosts of the Scoleri brothers, who terrorised Judge Wexler (Harris Yulin), who had sentenced them to death years earlier. This unfinished casting is made of unpainted pink foam rubber and depicts the oversized head of Nunzio's ghost with a ghastly grin. It has small air pockets from casting and exhibits some grime and discoloration from age. Dimensions: 31.75 cm x 45.75 cm x 29.25 cm (12.5" x 18" x 11.5")

**Estimate: £1,500 - 3,000**



**1152**  
Crew Gift Orb of Garraka, Crew Gift  
Hammer of Truth and Crew Coins  $\Delta$   
**Ghostbusters:  
Frozen Empire (2024)**

A crew gift Orb of Garraka, a crew gift Hammer of Truth and two crew coins from the production of Gil Kenan's sci-fi comedy sequel Ghostbusters: Frozen Empire. The orb released Garraka, the film's main antagonist that the Ghostbusters had to defeat.

The crew gift version of the Orb of Garraka is made of resin, as is the stand it is displayed on. The Hammer of Truth is a miniature version comprising a resin head and a wooden handle partially wrapped in string, displayed on a wooden stand. The two metal crew coins are held in a wooden plaque. Dimensions (orb): 13.5 cm x 13.5 cm x 16 cm (5.25" x 5.25" x 6.25")

**Estimate: £500 - 1,000**

**1153**  
Three Manhole Covers  $M$   
**Ghostbusters: Frozen Empire (2024)**

A set of three manhole covers from Gil Kenan's sci-fi comedy sequel Ghostbusters: Frozen Empire. In the film's opening sequence, manhole covers shot up from the streets of New York City as the Ghostbusters raced in the Ecto-1 to catch a ghost. Each of these resin covers is a different size and finished to look like metal. Dimensions (largest): 105 cm x 105 cm x 2 cm (41.25" x 41.25" x 0.75")

**Estimate: £500 - 1,000**





**1154**  
Collection of Crew Items m  
**Ghostbusters: Frozen Empire (2024)**

A collection of crew items from the production of Gil Kenan's sci-fi comedy sequel Ghostbusters: Frozen Empire.

The collection includes a size "L" red Kariban coat made of polyester featuring Firehouse and Ghostbuster badges; a size "L-XL" crew cap; a cotton crew beanie; a size "L" prop modelling department crew T-shirt; a size "L" crew T-shirt; and a Winnersh postcard that thanks crew members and features the printed autographs of Paul Rudd and Carrie Coon. The crew coat replicates those worn by the Ghostbusters during the film.

**Estimate: £500 - 1,000**



**1155**  
Cast-autographed Sign m  
**Ghostbusters: Frozen Empire (2024)**

A cast-autographed sign from the production of Gil Kenan's sci-fi comedy sequel Ghostbusters: Frozen Empire. The flexible plastic sign features the iconic film logo and fifteen cast autographs: Bill Murray, Dan Aykroyd, Ernie Hudson, Paul Rudd, Carrie Coon, Kumail Nanjiani, Finn Wolfhard, McKenna Grace, Patton Oswalt, William Atherton, Annie Potts, Logan Kim, Celeste O'Connor, Emily Alyn Lind and James Acaster. "Firehouse 2023" is handwritten on the back. Dimensions: 36 cm x 76 cm (14.25" x 30") The autographs in this lot have been professionally authenticated by expert Garry King; see notice in the Buyer's Guide.

**Estimate: £1,000 - 2,000**

**1156**  
Charioteer Armour and Helmet m  
**Gladiator (2000)**

A Charioteer's armour and helmet from Ridley Scott's Academy-award winning historical epic Gladiator. Maximus (Russell Crowe) fought with his fellow Gladiators against a unit of chariots during a re-enactment of the Battle of Carthage inside the monumental Colosseum. The chest armour is made of plastic, coated in robust rubber and features raised swirling patterns. It is painted to resemble gold and is fastened at the sides by buckled leather straps, with faux leopard skin attached and splashes of stage blood. "6 Alessandro" is handwritten on the inside of the chest piece in white marker pen and again in black ink on a costume label. The helmet is made of plastic, painted to look like metal, and features a brown-and-white faux-horsehair plume, as well as foam padding inside for comfort. The lot is accompanied by a framed production still of the relevant characters in action and a certificate of authenticity. Dimensions (photograph in frame): 40.5 cm x 32.25 cm x 2 cm (16" x 12.75" x 0.75")

**Estimate: £1,500 - 3,000**



**1157**  
Praetorian Standard m  
**Gladiator (2000)**

A Praetorian standard from Ridley Scott's historical epic Gladiator. Praetorian soldiers carried standards when Marcus Aurelius (Richard Harris) greeted Maximus (Russell Crowe) after the opening battle and when Commodus (Joaquin Phoenix) returned to Rome as Emperor. Designed by material sourcing company Rangarsons, this purple cotton and canvas standard is emblazoned "Praetoria VIII" above an olive branch garland in gold-colour thread. It is attached to a wooden staff. The standard is accompanied by a letter of authenticity from RareProps. Dimensions: 283 cm x 72 cm x 8 cm (111.5" x 28.25" x 3.25") Special shipping required; see special shipping notice in the Buyer's Guide.

**Estimate: £600 - 1,200**



**1158**  
Praetorian Lion Standard m  
**Gladiator (2000)**

A Praetorian standard from Ridley Scott's historical epic Gladiator. Praetorian soldiers carried standards when Marcus Aurelius (Richard Harris) greeted Maximus (Russell Crowe) after the opening battle and when Commodus (Joaquin Phoenix) returned to Rome as Emperor. Designed by material sourcing company Rangarsons, this purple cotton and canvas standard is emblazoned with a lion head circled by an olive branch garland in gold-colour thread. It is attached to a wooden staff. Dimensions: 283 cm x 72 cm x 8 cm (111.5" x 28.25" x 3.25") Special shipping required; see special shipping notice in the Buyer's Guide.

**Estimate: £600 - 1,200**



**1159**  
Gladiator's "Battle of Carthage" Shield †  
**Gladiator (2000)**

A gladiator's "Battle of Carthage" shield from Ridley Scott's Academy Award-winning historical epic Gladiator. Maximus (Russell Crowe) and his fellow gladiators defended themselves with shields during the re-enactment of the Battle of Carthage. The shield is made of rigid card and covered in decorated dark blue canvas, with red canvas on the rear. A folded metal trim finished in faux bronze runs around the edge, and attached to the front is a shield boss made of plastic and finished in steel-coloured paint. A wooden handle is attached to the rear. Dimensions: 22 cm x 70 cm x 101.5 cm (8.75" x 27.5" x 40")

**Estimate: £2,000 - 4,000**

**1160**  
Roman Gladius †  
**Gladiator (2000)**

A Roman Gladius from Ridley Scott's 2000 Oscar®-winning action epic *Gladiator*. Throughout the film, Roman soldiers and Gladiators, including Maximus (Russell Crowe), wielded Gladius swords. The gladius' blade is aluminium, embellished with stage blood and dents in the edges to appear battle-worn. The hilt is wooden, with both the guard and the grip ribbed. Dimensions: 74 cm x 13 cm x 13 cm (29.25" x 5" x 5")

**Estimate: £1,000 - 2,000**



**1161**  
Roman Legionaries Shield, Sword and Scabbard †  
**Gladiator (2000)**

A Roman Legionaries shield, sword and scabbard from Ridley Scott's Academy Award-winning historical epic *Gladiator*. Roman Legionaries, under the command of Maximus Decimus Meridius (Russell Crowe), fought against Germanic tribes in the opening battle sequence. The sword comprises an aluminium blade with a wooden hilt. The scabbard's main body is wood wrapped in a black-painted fabric. Metal sections connect it to a leather strap for wearing. The shield is predominantly wood, including its handle, while the edges are metal, and the boss is fibreglass. All items exhibit intentional distressing by the production so that they appear battle-worn. Dimensions (shield): 14 cm x 71 cm x 102 cm (5.5" x 28" x 40.25")

**Estimate: £1,000 - 2,000**

**1162**  
Infantry Gladius and Shield ◊  
**Gladiator (2000)**

An infantry gladius and shield from Ridley Scott's *Gladiator*. Roman general Maximus (Russell Crowe) commanded his legions of armed Roman infantry soldiers in the film's opening campaign against barbarians in Germania. This lot consists of a shield made of wood and metal covered with painted canvas featuring a wooden handle at the back and decorated with gold-colour wings and a plastic dome in the centre which is painted to resemble metal; and a sword made of metal with resin and wood components for the grip, painted in a brown wooden finish with a gold-colour strip around the guard's band which is carved "SPQR," and the pommel. The pommel's floral decoration at its head has since been lost, and the guard has seemingly been replaced for a standard infantry guard during its life in use on the production. This lot exhibits tarnishing to the blade and scuffing grime to the shield. Dimensions: (largest) 103 cm x 72 cm x 15 cm (40.75" x 28.5" x 6")

**Estimate: £1,000 - 2,000**

**1163**  
Two Helmets, an Infantry Gladius  
and an Incendiary Bomb †  
**Gladiator 2 (2024)**

Two helmets, an infantry gladius and an incendiary bomb from Ridley Scott's long-awaited historical epic sequel *Gladiator 2*. Soldiers of Rome were seen throughout the film wearing their armour. The first helmet is made of hard rubber and painted to look like metal. "B901" is handwritten on the inner lining beside a label with "627" handwritten in black marker. The second helmet is leather with a plaster inner lining and top. The gladius's blade is aluminium, while the hilt is wood. Its accompanying scabbard is wood wrapped in red-painted fabric, with metal plating and a leather sling attached. The bomb is made of biscuit foam with straw wrapping at its top. A pair of resin ram emblems are also included in the lot. The gladius' pommel has come unscrewed. Dimensions (sword unsheathed): 70.5 cm x 9 cm x 6.5 cm (27.75" x 3.5" x 2.5")

**Estimate: £1,000 - 2,000**



**1164**  
Godzilla Bust ◊  
**Godzilla (1998)**

A Godzilla bust from Roland Emmerich's *Godzilla*. Production utilised busts such as this for painting tests. *Godzilla* was the first *Godzilla* franchise film to be completely produced by a Hollywood studio and won a Saturn Award for Best Special Effects. Composed of hard resin with a urethane core, this detailed bust is painted grey and comes mounted to a metal and wood stand. It exhibits chipped paint and unpainted edges at the bottom. Dimensions: 45.75 cm x 30.5 cm x 68.5 cm (18" x 12" x 27")

**Estimate: £3,000 - 6,000**



**1165**  
Dr. Sean Maguire's (Robin Williams) Shirt ◊  
**Good Will Hunting (1997)**

Dr. Sean Maguire's (Robin Williams) shirt from Gus Van Sant's *Good Will Hunting*. Dr. Maguire wore his shirt during his first counselling session with Will Hunting (Matt Damon) as part of Will's parole sentencing. This lot consists of a yellow cotton Anto short-sleeve, button-down shirt labelled "RW April 1997" with red and blue stripes. This shirt exhibits minor loose threads.

**Estimate: £1,500 - 3,000**



**1166**  
Clint Eastwood Large Autographed Photo m  
**The Good, The Bad And The Ugly (1966)**

A large autographed photo of Clint Eastwood from Sergio Leone's Western classic The Good, the Bad and the Ugly. Eastwood autographed this photo of his iconic character - Blondie/The Man with No Name - in black ink. It is displayed in a custom-made frame. Dimensions: (photograph) 50.5 cm x 61 cm (20" x 24"), (frame) 76 cm x 86 cm x 3 cm (30" x 33.75" x 1.25")

The autographs in this lot have been professionally authenticated by expert Garry King; see notice in the Buyer's Guide.

**Estimate: £1,000 - 2,000**



**1167**  
David Frangioni Collection: US Six Sheet, 1968 m  
**The Good, The Bad And The Ugly (1966)**

A US Six Sheet promoting Sergio Leone's The Good, The Bad and The Ugly. The film is lauded as one of the greatest spaghetti Westerns ever made, with any paper from the film highly sought after. Offered here is an incredibly scarce US Six Sheet printed into four separate sections, with this example retaining its bright colours. The posters are folded and have some minor handling wear, but overall remain in very fine condition. Dimensions: 206 cm x 206 cm (81" x 81")

**Estimate: £1,000 - 2,000**

**1168**  
One-Eyed Willie Coin m  
**The Goonies (1985)**

A One-Eyed Willie treasure coin from Richard Donner's adventure comedy The Goonies. Assorted coins formed the vast treasure hoard found aboard hidden ship The Inferno, the last resting place of pirate captain One-Eyed Willie. Custom-made for the production, the faux-gold metal coin displays intentionally uneven edges, and is decorated with a cast-in lattice and Spanish crest detailing. The coin comes mounted on a custom-made display that features the film title and a brief description, as well as stills of the coin as it appeared in the film. Dimensions (display): 45cm x 40cm x 3cm (18" x 16" x 1")

**Estimate: £1,000 - 2,000**



**1169**  
Cast-autographed Poster m  
**The Goonies (1985)**

A poster for Richard Donner's adventure film The Goonies, autographed by the main members of the cast. Sean Astin (Mikey), Corey Feldman (Mouth), Kerri Green (Andy), Martha Plimpton (Stef), and Ke Huy Quan (Data) have signed the poster in white marker pen. The actors have also written famous quotes from their respective characters on the poster, such as "Does Brand wear braces?" and "Goonies never say die". Dimensions: 59 cm x 42 cm (23.25" x 16.5") The autographs in this lot have been professionally authenticated by expert Garry King; see notice in the Buyer's Guide.

**Estimate: £500 - 1,000**

**1170**  
Jack Johnson-Autographed Script m  
**The Goonies (1985)**

A Jack Johnson-autographed script from Richard Donner's The Goonies. A group of friends who called themselves the "Goonies" went on a treasure hunt in their town to save their homes from a big timer buyer from turning the area into a golf course. Used by film production illustrator Jack Johnson, this lot consists of a 114-page green script. The script is an early draft version that includes a cemetery scene marked as "56: Cemetery." The front of the script is also marked "Goonies" and autographed by Johnson in black ink. This script exhibits discolouration throughout and is missing the cover page. Dimensions: 21.75 cm x 28 cm x 1.75 cm (8.5" x 11" x 0.75")

**Estimate: £1,200 - 2,400**

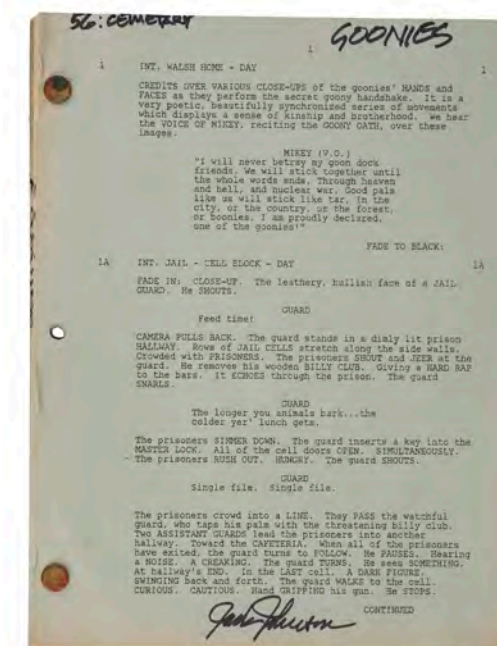

**1171**  
Set of One-Eyed Willie's Coins and Treasure m  
**The Goonies (1985)**

A set of One-Eyed Willie's coins and treasure from Richard Donner's The Goonies. Assorted coins formed the vast treasure hoard found aboard One-Eyed Willie's abandoned pirate ship, the Inferno. This lot consists of four gold- and silver-colour painted metal Spanish coins; three gold-colour painted metal stamped bars; and a faux diamond covered cross. This lot exhibits tarnishing and a broken arm on the cross with glue residue. Dimensions: (largest) 18.25 cm x 7.75 cm x 4 cm (7.25" x 3" x 1.5")

**Estimate: £2,000 - 4,000**



**1172**  
**Painting of Two Nudes Kissing m**  
**The Grand Budapest Hotel (2014)**

A painting of two nudes kissing from Wes Anderson's comedy-drama The Grand Budapest Hotel. Zero (Tony Revolori) and M. Gustave (Ralph Fiennes) used the controversial painting as a decoy to replace "Boy with Apple" when they liberated the masterpiece following the reading of Madame D's (Tilda Swinton) will. The artwork features two nude women in a loving embrace mounted on a wooden board. It is a reproduction of an original painting created by artist Rich Pellegrino - in the style of Egon Schiele - specifically for the movie. The back of the board features two aged labels, one with the artist's name, the other detailing a fictional loan to a museum. The top left corner has been torn away and it displays some creasing. Dimensions: 57 cm x 69 cm x 0.5 cm (22.5" x 27" x 0.75")

**Estimate: £800 - 1,600**



**1175**  
**Madame D's (Tilda Swinton) Letter to M Gustave**  
**(Ralph Fiennes) and 100 Klubek Bill †**  
**The Grand Budapest Hotel (2014)**

Madame D's (Tilda Swinton) letter to M Gustave (Ralph Fiennes) and a 100 Klubek bill from Wes Anderson's comedy drama film The Grand Budapest Hotel. Gustave received the letter from Madame D with 1000 Klubeks in bills of 100 enclosed, as a gift. Included in this lot is the letter, its envelope, and a 100 Klubek bill. The envelope is addressed to "M. Gustave", and the letter simply reads "For my dearest Gustave With love, Madame D.", and has a red lipstick print beneath the writing. The bill is stained, but otherwise the items remain in very good condition. Dimensions: 16.5 cm x 12 cm (6.5" x 4.75")

**Estimate: £500 - 1,000**



**1173**  
**Occupied Budapest ZZ Flag, ZZ Stationary and Letters †**  
**The Grand Budapest Hotel (2014)**

An occupied Budapest ZZ flag, stationary and letters from Wes Anderson's comedy drama film The Grand Budapest Hotel. While under military command, the hotel began using the 'ZZ' emblem on their keys, and all letters were postmarked with the symbol, as well as decorating the hotel with ZZ. Included in this lot are a ZZ flag, letters, letterheaded Grand Budapest paper, and a tag, all of which are stamped with the ZZ symbol. The letters are largely illegible, and written on Sudetenwaltz Monastery, C. Derriey and Bal de Lutz letterheaded paper. There are pencil marks on the tag, but otherwise all the items remain in excellent condition. Dimensions: 46 cm x 32 cm x 2 cm (18.25" x 12.75" x 0.75")

**Estimate: £800 - 1,600**



**1174**  
**Arrest Warrant and Carpet †**  
**The Grand Budapest Hotel (2014)**

An arrest document and carpet from Wes Anderson's comedy drama film The Grand Budapest Hotel. Lavish carpeting decorated the rooms of the Grand Budapest hotel, and the arrest warrant was for the arrest of M. Gustave (Ralph Fiennes), wrongly accused of murdering the hotel's owner Madame Celine Villeneuve Desgoffe-und-Taxis (Tilda Swinton). The carpet is cut from the border section of the hotel's carpets, and is red with a gold pattern, and the arrest warrant is complete with the details of Gustave's crime, address, and bail amount. The carpet has been rolled for storage, but otherwise the items remain in very good condition. Dimensions (carpet): 26 cm x 13 cm x 10 cm (10.25" x 5.25" x 4")

**Estimate: £800 - 1,600**

**1176**  
**Mendl's Patisserie Box †**  
**The Grand Budapest Hotel (2014)**

A Mendl's patisserie box from Wes Anderson's The Grand Budapest Hotel. Agatha (Saoirse Ronan) worked at Herr Mendl's (Rainer Reiners) bakery where M. Gustave (Ralph Fiennes) and Zero (Tony Revolori) later used the patisserie boxes to sneak in tools to help M. Gustave escape prison. This box is made of pink paper-wrapped cardboard with Mendl's logo printed in red ink on either side and tied with a blue nylon ribbon. This lot exhibits minor discolouration on the ribbon. Dimensions: 12.75 cm x 12.75 cm x 12.75 cm (5" x 5" x 5")

**Estimate: £1,000 - 2,000**



**1177**  
**Hotel Desk Set Dressing, Letters, Key Fob**  
**and Staff Notes †**  
**The Grand Budapest Hotel (2014)**

Hotel desk set dressing, letters, staff notes and a key fob from Wes Anderson's comedy drama film The Grand Budapest Hotel. Included in this lot are various maps, tourist pamphlets, photos, letters, envelopes, a newspaper, notes to hotel guests, and various other miscellaneous paperwork, including police reports. The key fob is for room 509, and the staff notes are written on Grand Budapest letterheaded paper, and largely contain instructions for guests, such as how to make outbound calls. The newspaper is a copy of the "Trans-Alpine Yodel". Some of the paperwork exhibits tearing and stains, but largely the items remain in good condition. Dimensions: 30 cm x 21 cm x 2 cm (12" x 8.25" x 1")

**Estimate: £800 - 1,600**





**1178**  
Cast-autographed Clapperboard m  
**Great Expectations (1998)**

An autographed clapperboard from the production of Mike Newell's 2012 adaptation of Charles Dickens' Great Expectations. This clapperboard features an acrylic slate and a wooden clapper. It has the film's title above the roll, scene and take numbers, which are handwritten in black ink, and the board is dated "9th November, 2011". It has been autographed on the reverse side by Robbie Coltrane (Mr Jaggers), Helena Bonham Carter (Miss Havisham), Ralph Fiennes (Magwitch), Jeremy Irvine (Pip), Mike Newell, and Jason Flemyng (Joe Gargery). Dimensions: 28 cm x 23.5 cm x 4.5 cm (11" x 9.25" x 1.75") The autographs in this lot have been professionally authenticated by expert Garry King; see notice in the Buyer's Guide.



**Estimate: £1,000 - 2,000**



**1179**  
Brain Gremlin SFX Insert Arms m  
**Gremlins 2: The New Batch (1990)**

A pair of Brain Gremlin SFX insert arms from Joe Dante's comedy-horror sequel Gremlins 2: The New Batch. These were made for scenes when it was easier to have the Brain Gremlin's arms puppeteered separately from the rest of the creature. The arms comprise a foam-latex skin over a metal armature. The hands are fully painted to match the gremlin's scaly skin and feature a latex claw on each finger. Dimensions (one arm): 63 cm x 21 cm x 11 cm (24.75" x 8.25" x 4.25")

**Estimate: £2,000 - 4,000**

**1180**  
Daffy Mogwai Face n  
**Gremlins 2: The New Batch (1990)**

A Daffy Mogwai face from the production of Joe Dante's horror-comedy sequel Gremlins 2: The New Batch. After scientists captured Gizmo at a laboratory in the Clamp Centre, the building was infested by a fresh batch of Gremlins. Rick Baker's Cinovation Studios produced an array of faces for each puppet to use within a modular system that involved changing the character's facial expressions by swapping in different masks. The mask comes with its original on-set storage box, which features labels with handwritten notes identifying it as "Smile - Type 3". Its skin is foam latex surrounded by orange and white faux fur. The lot is accompanied by a certificate of authenticity from Rick Baker. Dimensions (face): 6 cm x 13 cm x 12.5 cm (2.25" x 5" x 5")

**Estimate: £2,000 - 4,000**



**1182**  
George Mogwai Face n  
**Gremlins 2: The New Batch (1990)**

A George Mogwai face from the production of Joe Dante's horror-comedy sequel Gremlins 2: The New Batch. After scientists captured Gizmo at a laboratory in the Clamp Centre, the building was infested by a fresh batch of Gremlins. Rick Baker's Cinovation Studios produced an array of faces for each puppet to use within a modular system that involved changing the character's facial expressions by swapping in different masks. The mask comes with its original on-set storage box, which features handwritten notes on its top and contains a laminate card identifying this mask as "Regular - Type 1". Its skin is foam latex surrounded by black and white faux fur, while a plastic inner lining reveals itself through the eye sockets. The lot is accompanied by a certificate of authenticity from Rick Baker. Dimensions (face): 8 cm x 14 cm x 9.5 cm (3.25" x 5.5" x 3.75")

**Estimate: £2,000 - 4,000**



**1181**  
Mohawk Mogwai Face n  
**Gremlins 2: The New Batch (1990)**

A Mohawk Mogwai face from the production of Joe Dante's horror-comedy sequel Gremlins 2: The New Batch. After scientists captured Gizmo at a laboratory in the Clamp Centre, the building was infested by a fresh batch of Gremlins. Rick Baker's Cinovation Studios produced an array of faces for each puppet to use within a modular system that involved changing the character's facial expressions by swapping in different masks. The mask comes with its original on-set storage box, which features handwritten notes on its top and contains a laminate card identifying this mask as "Mean - Type 1". Its skin is foam latex surrounded by black and white faux fur. The lot is accompanied by a certificate of authenticity from Rick Baker. Dimensions (face): 9 cm x 16 cm x 19 cm (3.5" x 6.25" x 7.5")

**Estimate: £2,000 - 4,000**



**1183**  
Gizmo Mogwai Face n  
**Gremlins 2: The New Batch (1990)**

A Gizmo Mogwai face from the production of Joe Dante's horror-comedy sequel Gremlins 2: The New Batch. After scientists captured Gizmo at a laboratory in the Clamp Centre, the building was infested by a fresh batch of Gremlins. Rick Baker's Cinovation Studios produced an array of faces for each puppet to use within a modular system that involved changing the character's facial expressions by swapping in different masks. The mask comes with its original on-set storage box, which features handwritten notes on its top and contains a laminate card identifying this mask as "Smile - Type 3". Its skin is foam latex surrounded by orange and white faux fur. The lot is accompanied by a certificate of authenticity from Rick Baker. Dimensions (face): 6 cm x 14.5 cm x 9 cm (2.25" x 5.75" x 3.5")

**Estimate: £2,000 - 4,000**





**1184**  
Set of Joyce (Barbara Streisand) and Andrew Brewster's (Seth Rogen) Ephemera  $\alpha$   
**The Guilt Trip (2012)**

Joyce (Barbra Streisand) and Andrew Brewster's (Seth Rogen) ephemera from Anne Fletcher's *The Guilt Trip*. Joyce brought tour books and other supplies on her road trip with Andrew to help sell his latest cleaning product. Created by property master Hope Parrish, this set consists of Clic glasses; a velvet pillow; mesh travel pouch with bluetooth user guide; seven maps; four tour books; leather The Sak purse with two notepads, a wallet with Joyce's ID, cheque book, and faux production money; bluetooth earpiece with charging case and two replacement buds; purse hook; empty bottle of hand sanitizer; Wet Ones wipe; glasses lens cleaner cloth; powder setting compact; two rental car keychains with one key; travel pouch with makeup brushes, toothpicks, lip balm, tissues, and makeup; leather wallet with Andrew's ID and cards; seven laminated HSN ID badges with nylon lanyards; Costco Wholesale ID badge; and a resin-coated printed wooden dinner menu for Cattlemen's Roundup Steak House. This lot exhibits sticking badges, chipped resin on the menu, and wear to the leather. Dimensions: (largest) 44 cm x 37.5 cm x 1.5 cm (17.25" x 14.25" x 0.5") Contains electronics; see electronics notice in the Buyer's Guide.

**Estimate: £800 - 1,600**

**1185**  
Pumpkin Mask  $m$   
**Halloween III: Season Of The Witch (1982)**

A pumpkin mask from Tommy Lee Wallace's horror sequel *Halloween III: Season of the Witch*. The iconic Silver Shamrock Novelties pumpkin masks were seen throughout the film as Ellie (Stacey Nelkin) and Daniel (Tom Atkins) investigated their significance in the murder of her father. The supplier of the pumpkin masks, prop maker Don Post Studios, crafted this version from latex rubber, finishing it with a fluorescent orange paint job and a green stalk. The mask has been filled with foam by the previous owner. '1982, DINO DE LAURENTIIS CORP, A DON POST TRADEMARK' is marked subtly at the mask's rear. Dimensions: 29 cm x 26 cm x 24 cm (11.5" x 10.25" x 9.5")

**Estimate: £3,000 - 6,000**



**1186**  
Michael Myers (George P. Wilbur) Production-made Mask  $m$   
**Halloween: The Curse Of Michael Myers (1995)**

A Michael Myers (George P. Wilbur) production-made mask from Joe Chappelle's horror sequel *Halloween: The Curse of Michael Myers*. Returning to Haddonfield, Michael Myers, also known as The Shape, wore his notorious mask as he once again perpetrated several brutal murders while searching for his niece.

Just like its fellow renditions, the mask is based on the original design, which was an old Captain Kirk death mask from the *Star Trek* series. The costume designers have adapted this rubber mask by dyeing the surface with the infamously pale colour tone and adding faux hair at the back of the scalp.

The mask was gifted by Don Post Studios to Daniel Farrands, one of the three credited writers for the sixth instalment in the franchise. Behind-the-scenes footage from *The Curse of Michael Myers* shows Daniel's brother wearing the mask and performing as the character. The mask is now without the full layer of faux hair on the scalp. Dimensions: 25 cm x 16 cm x 31 cm (9.75" x 6.25" x 12.25")

**Estimate: £2,000 - 4,000**



**1187**  
Kai-125's (Kate Kennedy) SRS99-S7 AM Sniper Rifle  $\alpha$   
**Halo - Sword (2024)**

Kai-125's (Kate Kennedy) SRS99-S7 AM sniper rifle from Steven Kane and Kyle Killen's *Halo*. Kai carried her sniper rifle with her throughout Season 2, including when she and the other Spartans trained and convened by the waterfall after Riz (Natasha Culzac) fell in the episode "Sword." Featuring a custom sculpt redesigned for Season 2 for enhanced realism, this static resin rifle is stencilled "Push" alongside several static switches and applied with a warning decal at the stock. Production intentionally distressed this weapon to appear grimy and scuffed. This lot exhibits adhesive residue near the scope and chipped paint. Dimensions: 132 cm x 30.5 cm x 10.25 cm (52" x 12" x 4") Ownership may be restricted in some countries; see replica firearm notice in Buyer's Guide.

**Estimate: £2,000 - 4,000**



**1188**  
Keith Hamshere Collection: Collection of Production Photographs and Booklets  $m$   
**Hamlet (1991)**

A set of photos taken by Keith Hamshere during the production of Franco Zeffirelli's Shakespeare adaptation *Hamlet*. This lot comes from the personal collection of renowned stills photographer Keith Hamshere. The set comprises five books of black-and-white photographs, as well as a small collection of A3 coloured photos and a box of loose black-and-white photos. The photographs are a combination of behind-the-scenes stills, headshots of the cast in costume, shots of the crew, and ensemble photos of cast and crew. Dimensions: 39 cm x 39 cm x 9 cm (15.5" x 15.5" x 3.5") ISold without copyright; see copyright notice in the Buyer's Guide.

**Estimate: £800 - 1,600**



**1189**  
Hannibal Lecter's (Anthony Hopkins) Prison T-shirt with Photograph  $\dagger\Delta$   
**Hannibal (2001)**

Hannibal Lecter's (Anthony Hopkins) prison T-shirt, with a photograph of the notorious serial killer behind bars, from Ridley Scott's thriller sequel *Hannibal*. When reassigned to Lecter's case, Clarice Starling (Julianne Moore) studied police surveillance footage of him attacking a nurse while wearing a prison T-shirt. The T-shirt is a size "L", and exhibits minor stains from wear and use during production. Dimensions (photograph): 25.5 cm x 20.25 cm (10" x 8")

**Estimate: £2,000 - 4,000**



**1190**  
 Hannibal Lecter's (Mads Mikkelsen)  
 "Aperitif" River City Printed  
 Illustration M  
**Hannibal (2013-2015)**

Hannibal Lecter's (Mads Mikkelsen) framed office artwork from Bryan Fuller's thrilling drama series Hannibal. Framed pieces of artwork decorated various walls throughout Hannibal's office facility during the show's first season. The printed piece of art is displayed in a wooden frame with white matting. The piece features Hannibal's signature printed in the bottom right corner. Dimensions: 63 cm x 50 cm x 5.5 cm (24.75" x 19.75" x 2.25")

**Estimate: £600 - 1,200**

No lot 1191



**1192**  
 Harrison Ford  
 Autographed Yearbook M  
**Harrison Ford**

A Harrison Ford autographed yearbook from his time as a student at Maine East High School. The 1958 yearbook is signed "Harry Ford" on page three, alongside the message, "It was lots of fun this year, considering our mean ol' teacher was down my lilly [sic] white throat. Good luck all through your next two years at Main." Ford also appears in a photo on page 44 as a member of the Audio Visual service. The book cover has some minor staining and tears. Dimensions: 28 cm x 21 cm x 3 cm (11" x 8.25" x 1.25") The autographs in this lot have been professionally authenticated by expert Garry King; see notice in the Buyer's Guide.

**Estimate: £2,000 - 4,000**

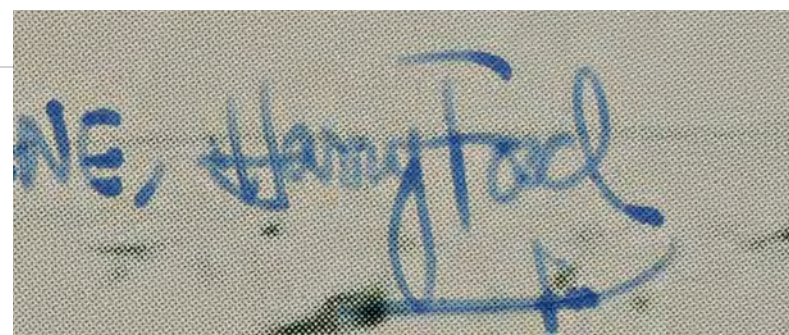

**1193**  
 Rick Baker-made Harry  
 (Kevin Peter Hall) Feet M  
**Harry And The Hendersons (1987)**

A pair of Harry (Kevin Peter Hall) feet, made by eminent makeup artist Rick Baker, from the production of William Dear's family comedy Harry and the Hendersons. Rick Baker has won seven Academy Awards in the Best Makeup category, including wins for his work on Harry and the Hendersons, How the Grinch Stole Christmas, and Men in Black. The feet are made of an outer layer of slip latex and an inner layer of flexible latex. Each foot is painted to match the rest of the character's appliances. The feet are finished with a top layer of faux brown hair. Dimensions (one foot): 46.5 cm x 20 cm x 20 cm (18.25" x 7.75" x 7.75")

**Estimate: £1,500 - 3,000**



**1194**  
 Pair of Ollivanders Wand Boxes  
 Premiere Gifts M  
**Harry Potter And The  
 Philosopher's Stone (2001)**

Two Ollivanders wand-box gifts from the premiere of Chris Columbus' fantasy-adventure film Harry Potter and the Philosopher's Stone. Given to the attendees, these wand boxes were originally part of the Ollivanders store set, seen in the iconic scene where Harry buys his first wand. Both boxes are made of cardboard with textured finishes; one is green and snakeskin-like, and the other is burgundy. Ollivanders shop labels are adhered to both boxes, while a metal armature runs through the green box. Dimensions (one box): 38 cm x 6 cm x 5.5 cm (15" x 2.25" x 2.25")

**Estimate: £2,000 - 4,000**



**1195**  
 Hogwarts Acceptance Envelope M  
**Harry Potter And The  
 Philosopher's Stone (2001)**

Harry Potter's (Daniel Radcliffe) Hogwarts acceptance letter from Chris Columbus' fantasy adventure film Harry Potter and the Philosopher's Stone. Owl post inundated the Dursley household with letters informing Harry of his acceptance into Hogwarts School of Witchcraft and Wizardry, despite Uncle Vernon's (Richard Griffiths) best efforts. This envelope is made from marble-effect paper, with Harry's address printed in green on the front, and the Hogwarts crest and a faux wax seal printed on the reverse. There are some small surface tears and minor glue remnants are on the envelope's back. Dimensions: 13.5 cm x 18.5 cm (5.75" x 7.25")

**Estimate: £400 - 800**

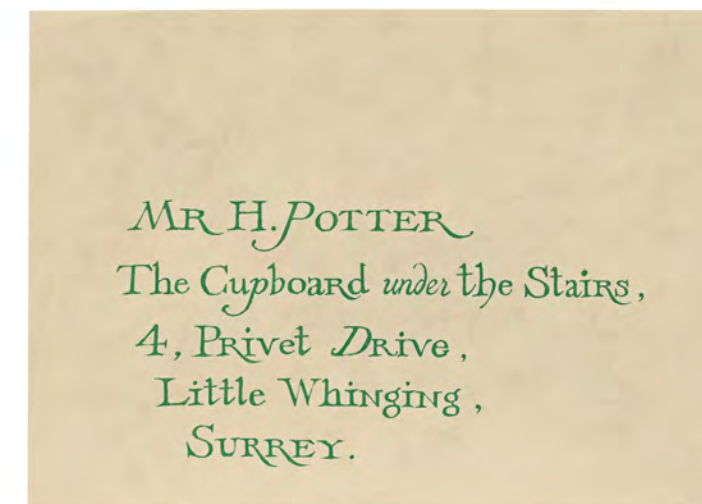

**1196**  
SFX Bludger M  
**Harry Potter And The Philosopher's Stone (2001)**

A SFX bludger from Chris Columbus' fantasy-adventure film Harry Potter and the Philosopher's Stone. Harry (Daniel Radcliffe) hit a bludger with a bat whilst learning about quidditch. This bludger was specifically designed for use later on in the film when Gryffindor competed against Slytherin in a game of quidditch. The bludger is made of rubber, designed to look like iron. A hole in the bludger has its shape maintained by a hollow metal cylinder. Through this hole, the bludger was mounted onto an air mortar, creating the effect of it being magically launched at the start of the game of quidditch. Dimensions: 15 cm x 15 cm x 15 cm (6" x 6" x 6")

**Estimate: £2,000 - 4,000**



**1197**  
Set of Five Hogwarts Acceptance Envelopes M  
**Harry Potter And The Philosopher's Stone (2001)**

Set of five Hogwarts acceptance envelopes from Chris Columbus' fantasy-adventure film Harry Potter and the Philosopher's Stone. Owl post inundated the Dursley household with letters informing Harry Potter (Daniel Radcliffe) of his acceptance into Hogwarts, despite Uncle Vernon's (Richard Griffiths) best efforts to stop them. The envelopes are made from marble-effect paper, with a faux red wax seal printed on the reverse side. The envelopes remain sealed, and as their features are printed, they were likely used for the owl delivery shots or for flying out of the house's fireplace and letterbox. Dimensions: (one letter) 18.5 cm x 13.5 cm (7.25" x 5.25")

**Estimate: £2,000 - 4,000**

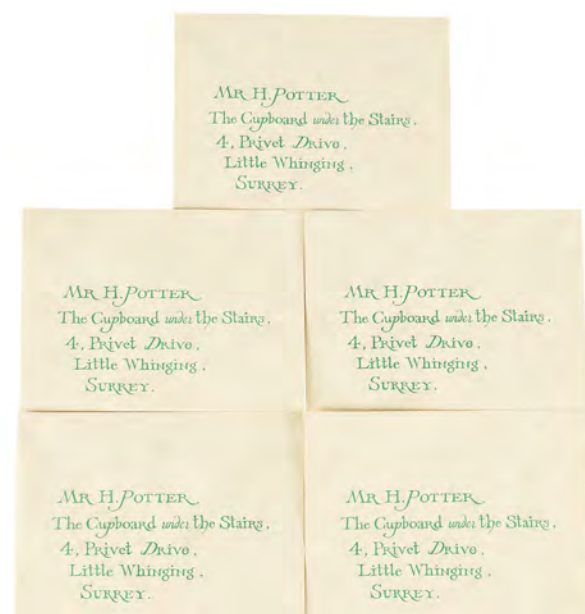

**1198**  
Crew Gift Pocket Watch M  
**Harry Potter And The Philosopher's Stone (2001)**

A crew gift pocket watch from Chris Columbus' fantasy-adventure film Harry Potter and the Philosopher's Stone. These watches were gifted to both the cast and production crew who worked on the film. The fob watch is made from gold-plated metal and features a white watch face detailed with black roman numerals, a lightning bolt for the 12, and gold-coloured stars. The watch has a length of chain running from it, which ends with a clasp. The watch is contained inside a display box, accompanied by a black velvet drawstring jewellery bag. The watch requires a new battery due to age. Dimensions: (watch without chain) 6.75 cm x 5 cm x 1.25 cm (2.75" x 2" x 0.5") Contains mechanical components; see mechanical notice in the Buyer's Guide.

**Estimate: £1,000 - 2,000**



**1199**  
Set of Gringotts Coins and Crew Gift Pocket Watch M  
**Harry Potter And The Philosopher's Stone (2001)**

A set of Gringotts coins and a crew gift pocket watch from Chris Columbus' fantasy-adventure film Harry Potter and the Philosopher's Stone. Harry (Daniel Radcliffe) visited Gringotts bank with Hagrid (Robbie Coltrane) and discovered the fortune his parents had left him. The lot includes two gold galleons, one silver sickle, and one bronze knut, all crafted from metal. The watch is made from gold-plated metal and features a white watch face detailed with black roman numerals, a lightning bolt for the 12, and gold-coloured stars. The watch is contained inside a display box, accompanied by a black velvet drawstring jewellery bag. Dimensions (watch box): 10.5 cm x 10.5 cm x 3 cm (4.25" x 4.25" x 1.25") Contains mechanical components; see mechanical notice in the Buyer's Guide.

**Estimate: £1,500 - 3,000**

**1200**  
Slytherin Scarf M  
**Harry Potter And The Philosopher's Stone (2001)**

A house Slytherin scarf from the Harry Potter film franchise. Slytherin students wore their scarves throughout the series, though this particular style is most visible in the first two films, Harry Potter and the Philosopher's Stone and Harry Potter and the Chamber of Secrets. The scarf is knitted, and features green and grey alternating stripes, with alternating green and grey tassels at either end.

**Estimate: £500 - 1,000**



**1201**  
Pair of Harry Potter Wand Boxes M  
**Harry Potter And The Philosopher's Stone (2001)**

Pair of wand boxes from Christopher Columbus' fantasy-adventure film Harry Potter and the Philosopher's Stone. Stacks of boxes filled the shelves of Ollivanders, the shop Harry Potter (Daniel Radcliffe) visited in Diagon Alley to purchase a wand. Included are a blue box, with a textured lid, and a green box that is untextured. Both feature an oval gold-coloured Ollivanders-branded label and stickers affixed to one end with their wand numbers - the blue reads "873", the green "6058". Dimensions (blue box): 37 cm x 8.5 cm x 2.5 cm (14.5" x 3.5" x 1")

**Estimate: £2,000 - 4,000**



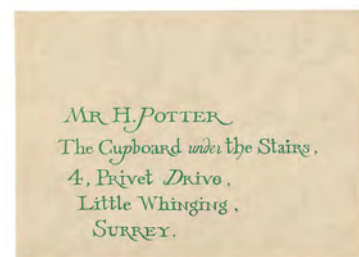

**1202**  
 Harry Potter Wand Box and Envelope m  
**Harry Potter And The Philosopher's Stone (2001)**

A wand box and envelope from Christopher Columbus' fantasy-adventure film Harry Potter and the Philosopher's Stone. Harry (Daniel Radcliffe) received a number of letters from Hogwarts inviting him to study, which were destroyed by Vernon Dursley (Richard Griffiths), and stacks of boxes filled the shelves of Ollivanders, the shop Harry visited in Diagon Alley to purchase a wand. The sealed lid of the cardboard box features a green textured effect and an oval gold-coloured Ollivanders-branded label. There is a small metal hoop attached at one end, to make retrieval from the shelf easier. The envelope is addressed to "Mr H Potter, The Cupboard Under the Stairs, 4, Privet Drive, Little Whinging, Surrey" and features the Hogwarts coat of arms on the back, as well as a printed image of a wax seal. The Envelope is sealed shut. Dimensions (box): 36 cm x 5.5 cm x 6 cm (14.24" x 2.25" x 2.5")

**Estimate: £1,000 - 2,000**

**1203**  
 Set of Three Wizard Portraits m  
**Harry Potter And The Philosopher's Stone (2001)**

A set of three wizard portraits from Chris Columbus' fantasy film Harry Potter and the Philosopher's Stone. Portraits of witches and wizards lined the walls around the floating staircases in Hogwarts. Each of the three photos is framed, two feature portraits and one features only a background, presumably to facilitate its use as one of the film's "moving portraits". The paintings come with three plaques, displaying the names of pictured wizards, "Seraphina Bones", "The Greatets Ever User of Love Potions, Oswald Plumpton", and "Ibengist Rawke". Two of the portraits feature exposed metal screws emerging from the back, likely from being hung on set, and metal backings which exhibit some rust. Each of the paintings has handwritten numbers on the back - the smallest reads "F201", the portrait of a man in green reads "C386" and "C5.41", and the final portrait reads "C5100", "HF4", and "C460". Dimensions: 29 cm x 24.5 cm x 8 cm (11.5" x 9.75" x 3.25")

**Estimate: £2,000 - 4,000**



**1204**  
 Pair of Wizard Portraits m  
**Harry Potter And The Philosopher's Stone (2001)**

A pair of wizard portraits from Chris Columbus' fantasy film Harry Potter and the Philosopher's Stone. Portraits of witches and wizards lined the walls around the floating staircases in Hogwarts School of Witchcraft and Wizardry. One portrait features a family, the other a single member of the same family. Included with the portraits are four plaques displaying wizards' names: "Stump", "Mr Roderick Pratt", "Groyne", and "Ricardo Cruikshank Supreme Mugwump". Both portraits are framed in resin frames painted gold. The back of the smaller portrait has "Hero W30" handwritten on it, and the back of the larger portrait has "HeroW6" and "C4.2" handwritten on it. Both portraits have metal screws protruding from the rear, and metal backs that exhibit some rust. Dimensions: 52 cm x 43 cm x 8 cm (20.5" x 17" x 3.25")

**Estimate: £2,000 - 4,000**



**1205**  
 Daniel Radcliffe and Cast-Autographed Book m  
**Harry Potter And The Philosopher's Stone (2001)**

An autographed book from Chris Columbus' fantasy film Harry Potter and the Philosopher's Stone. The book, a hardback copy of J.K. Rowling's Harry Potter and the Philosopher's Stone, has been autographed on the title page by three of the leading cast members: Daniel Radcliffe, who plays Harry Potter, Rupert Grint, who plays Ron Weasley, and Emma Watson, who plays Hermione Granger. Each actor has written their character's name beneath their autograph. Dimensions: 21 cm x 14 cm x 2 cm (8.25" x 5.5" x 1") The autographs in this lot have been professionally authenticated by expert Garry King; see notice in the Buyer's Guide.

**Estimate: £1,000 - 2,000**



**1207**  
 Daniel Radcliffe, Emma Watson, Rupert Grint and Cast-Autographed Poster m  
**Harry Potter And The Philosopher's Stone (2001)**

A cast-autographed promotional poster from Chris Columbus' fantasy-adventure film Harry Potter and the Philosopher's Stone. The poster shows an owl holding Harry's (Daniel Radcliffe) Hogwarts acceptance letter, and has been autographed by seven members of the cast: Daniel Radcliffe, Emma Watson, Rupert Grint, Robbie Coltrane, Alan Rickman, Julie Walters, and John Cleese. Radcliffe has written "Best Wishes" alongside his autograph. The poster also features the film's alternative US title, 'Harry Potter and the Sorcerer's Stone', and comes mounted in a wooden frame. Dimensions: 109 cm x 76 cm x 2.5 cm (43" x 30" x 1") The autographs in this lot have been professionally authenticated by expert Garry King; see notice in the Buyer's Guide.

**Estimate: £2,000 - 4,000**

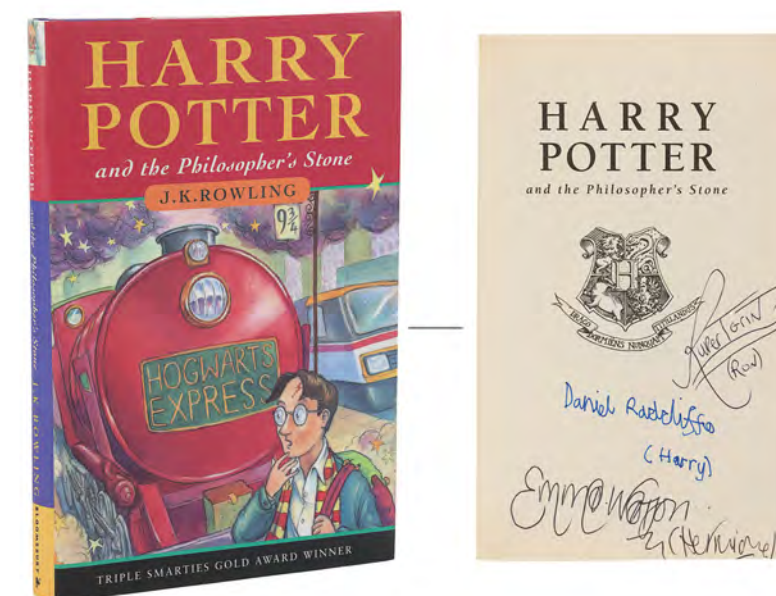

**1206**  
 Daniel Radcliffe-autographed Production Copy Script m  
**Harry Potter And The Philosopher's Stone (2001)**

A production copy script autographed during filming by Daniel Radcliffe from the production of Chris Columbus' Harry Potter and the Philosopher's Stone. This script copy is 125 pages long (the first three pages are omitted) and watermarked "82" throughout. Radcliffe has autographed the cover page alongside his character's name in black ink. The script is bound with a metal fastener and has some very minor staining. Dimensions: 30 cm x 21.5 cm x 1.5 cm (11.75" x 8.5" x 0.5") The autographs in this lot have been professionally authenticated by expert Garry King; see notice in the Buyer's Guide.

**Estimate: £2,000 - 4,000**



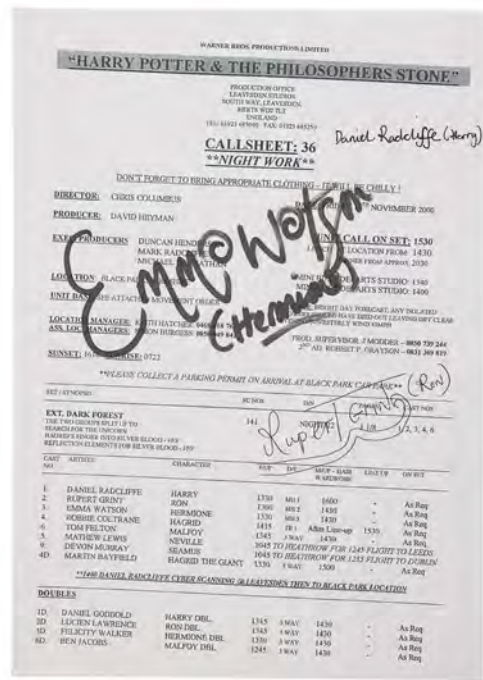

**1208**  
Daniel Radcliffe, Emma Watson and Rupert Grint  
Autographed Call Sheet Copy **M**  
**Harry Potter And The Philosopher's Stone (2001)**

An autographed call sheet signed during filming of Chris Columbus' fantasy-adventure film Harry Potter and the Philosopher's Stone. Dated "Friday 17th November 2000", this document is titled "Callsheet: 36" and concerns the external scenes set in the Dark Forest. It features a list of scheduled screen tests and call times for key cast members and doubles. The original call sheet was photocopied on set and then autographed in black ink by the film's three stars, Daniel Radcliffe (Harry Potter), Rupert Grint (Ron Weasley) and Emma Watson (Hermione Granger). Dimensions: 30 cm x 21 cm (11.75" x 8.25") The autographs in this lot have been professionally authenticated by expert Garry King; see notice in the Buyer's Guide.

**Estimate: £800 - 1,600**



**1209**  
Hufflepuff Quidditch Stadium Banners **TD**  
**Harry Potter And The Philosopher's Stone (2001)**

Hufflepuff quidditch stadium banners from Chris Columbus' adventure fantasy Harry Potter and the Philosopher's Stone. Team banners were seen adorning the stands of the Hogwarts quidditch stadium as Gryffindor took on Slytherin. The lot includes one large linen banner depicting a badger, the house's emblematic animal, and a small linen banner in Hufflepuff's house colours. The banners exhibit dirt stains and tears on some of their corners.  
Dimensions: 188 cm x 65.5 cm (74" x 25.75")

**Estimate: £800 - 1,600**

**1210**  
Gringotts Bank Ledger, Quill, Daily  
Prophet Newspaper, Coin Bag and  
Coins, and Gold Bars **M**  
**Harry Potter And The Philosopher's  
Stone (2001)**

A collection of Gringotts Bank items from Chris Columbus' fantasy adventure film Harry Potter and the Philosopher's Stone. The goblins of Gringotts Bank kept cheques on their desks, speared on metal spikes, and Harry Potter (Daniel Radcliffe) later read about a break-in at the bank in a copy of the Daily Prophet newspaper). This lot comprises a Gringotts bank ledger; two Gringotts Bank cheques; a black feather quill; a Daily Prophet newspaper; a Gringotts Bank coin bag containing foam coins; and two gold bars, one large, one small. The coin bag is filled with grey foam nuggets to mimic coins and has a drawstring closure. The gold bars are made of plastic and painted gold. The bars exhibit some minor wear, and each cheque features a small hole from the tellers' metal spikes. However, all the items remain in otherwise very good condition.  
Dimensions: 60 cm x 30 cm x 10 cm (23.75" x 11.75" x 4")

**Estimate: £4,000 - 8,000**



**1211**  
Golden Snitch Executive Gift **Ω**  
**Harry Potter And The Sorcerer's Stone (2001)**

A golden snitch executive gift from the promotion of Chris Columbus' Harry Potter and the Sorcerer's Stone. Replicas of the golden snitch from the film's Quidditch scenes were gifted to Warner Bros. executives and VIPs to commemorate the film's release. Only 50 are thought to have been produced. This snitch is constructed of gold-colour plated brass with wings featuring a chrome-colour finish. Also included is a custom-made wooden box with a black velvet interior, brass clasps, and a brass plaque reading "Golden Snitch." The lot exhibits minor scuffs from handling. Dimensions: 21.75 cm x 12.75 cm x 11.5 cm (8.5" x 5" x 4.5") Additional Provenance: Certificate of Authenticity from Warner Bros. Consumer Products

**Estimate: £1,500 - 3,000**

**1212**  
Gilderoy Lockhart (Kenneth Branagh)  
Set Dressing Book and Prototype SFX  
Nimbus Broom **TD**  
**Harry Potter And The Chamber Of Secrets  
(2002)**

A prototype broom from the production of Chris Columbus' fantasy-adventure Harry Potter and the Philosopher's Stone and a Gilderoy Lockhart (Kenneth Branagh) set dressing book from the sequel Harry Potter and the Chamber of Secrets. In the first film, Harry Potter (Daniel Radcliffe) learnt to fly on a broom during a class taught by Madame Hooch (Zoë Wanamaker). In the sequel, Lockhart's books were seen in Diagon Alley and his classroom at Hogwarts. The prototype comprises a metal handle and a wooden broom section. Lockhart's book has a paper cover and is filled in with polystyrene.  
Dimensions (broom): 179 cm x 24.5 cm x 15.5 cm (70.5" x 9.75" x 6")

**Estimate: £750 - 1,500**



**1213**  
Gilderoy Lockhart (Kenneth Branagh) Photograph **M**  
**Harry Potter And The Chamber Of Secrets (2002)**

A Gilderoy Lockhart (Kenneth Branagh) photograph from Chris Columbus' fantasy adventure sequel Harry Potter and the Chamber of Secrets. Harry Potter (Daniel Radcliffe) served detention by helping Lockhart reply to his fan mail, including a magically moving photograph of the Defence Against the Dark Arts Professor posing on a broom, which he autographed. This photograph forms part of a stack of pictures that Lockhart is signing and is the same as the version of the photo that was seen moving on screen. Dimensions: 26.25 cm x 21 cm (10.25" x 8.25")

**Estimate: £1,000 - 2,000**



**1214**  
Flying Ford Anglia Name Badge m  
**Harry Potter And The Chamber Of Secrets (2002)**

A flying Ford Anglia name badge from Chris Columbus' 2002 fantasy sequel Harry Potter and the Chamber of Secrets. The flying Ford Anglia was driven twice in the film, first by Fred and George Weasley (James and Oliver Phelps) to rescue Harry (Daniel Radcliffe) from the Dursleys, and then again by Ron (Rupert Grint) and Harry to get to Hogwarts after they couldn't catch the Hogwarts Express. The badge is made of metal and exhibits some minor chipping, but otherwise remains in very good condition. Dimensions: 14.5 cm x 4 cm x 1 cm (5.75" x 1.5" x 0.5")

**Estimate: £400 - 800**

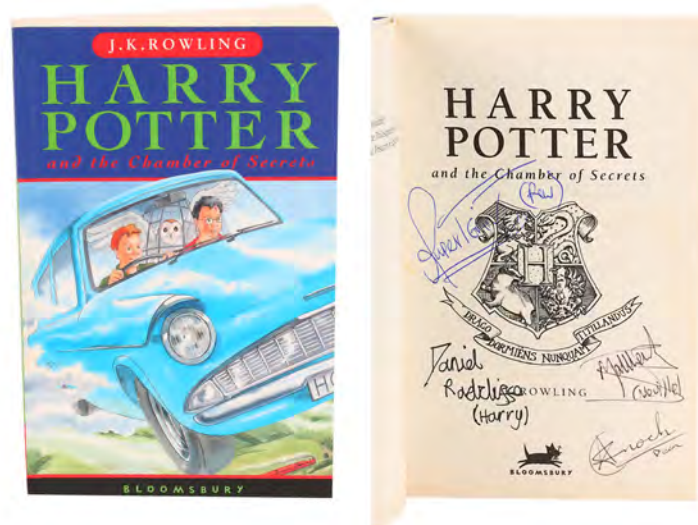

**1215**  
Daniel Radcliffe and Cast-Autographed  
Paperback Book 1Δ  
**Harry Potter And The Chamber Of Secrets (2002)**

A paperback copy of J.K. Rowling's novel Harry Potter and the Chamber of Secrets autographed by four actors from the film adaptation. Published by Bloomsbury, this 32nd print run paperback has its title page autographed in black and blue pen by Daniel Radcliffe (Harry Potter), Rupert Grint (Ron Weasley), Matthew Lewis (Neville Longbottom) and Alfred Enoch (Dean Thomas). Dimensions: 20 cm x 13 cm x 2 cm (7.75" x 5" x 0.75") The autographs in this lot have been professionally authenticated by expert Garry King; see notice in the Buyer's Guide.

**Estimate: £800 - 1,600**

**1216**  
VFX Crew Parka 1Δ  
**Harry Potter And The Prisoner Of Azkaban (2004)**

A VFX crew parka from the production of Alfonso Cuarón's fantasy sequel Harry Potter and the Prisoner of Azkaban. The parka is made of green polyester, with a zip fastening down the front and a faux-fur trim on the hood. "VFX Crew" is embroidered in white on the left breast and the back features an embroidered rectangular emblem in the style of a prisoner ID badge, which reads "Azkaban Prison, VFX 03, Prison Warders Association". The majority of the text on the internal label has faded, but the size "X Large" is still readable.

**Estimate: £400 - 800**



**1217**  
Boggart Wardrobe SFX Door Handle m  
**Harry Potter And The Prisoner Of Azkaban (2004)**

A Boggart wardrobe SFX door handle from Alfonso Cuarón's fantasy sequel Harry Potter and the Prisoner of Azkaban. Defence Against the Dark Arts teacher Professor Lupin (David Thewlis) taught Harry (Daniel Radcliffe) and his peers about Boggarts and how to repel them. This SFX door handle in which the boggart was contained is designed so that it would turn remotely when Lupin unlocked the wardrobe with a flick of his wand. The handle's brass knob is a bearded wizard's head that is attached to a metal cylinder-shaped mechanism for turning. Dimensions: 9.5 cm x 6 cm x 4.5 cm (3.75" x 2.25" x 1.75")

**Estimate: £400 - 800**

**1218**  
J.K. Rowling-Autographed Deluxe First Edition Book and  
Original Cliff Wright Watercolour m  
**Harry Potter And The Prisoner Of Azkaban (2004)**

A J.K. Rowling-autographed deluxe first edition copy of Harry Potter and the Prisoner of Azkaban, and an original watercolour by illustrator Cliff Wright. The deluxe edition was released on 8 July 1999, simultaneously with the trade edition, and only 1,000 copies were initially printed. This was the first instalment of the series published by Bloomsbury as a collector's edition. Rowling has autographed the book on the first page. The hardback book is bound in green cloth, with cover art by Cliff Wright, who also illustrated the cover of Harry Potter and the Chamber of Secrets. Accompanying the book is an original Cliff Wright watercolour of a boy stargazing with a telescope. A print of this image also appears inside the cover of the box the book is stored in. The illustration is hand-labelled "Azkaban 234" on the front and "Cliff Wright 2007" on the back. The lot is accompanied by a certificate of authenticity and additional information from Harry Potter specialist Adam Houston. Dimensions (box): 26 cm x 18 cm x 4.5 cm (10.25" x 7" x 1.75") Sold without copyright; see copyright notice in the Buyer's Guide. The autographs in this lot have been professionally authenticated by expert Garry King; see notice in the Buyer's Guide.

**Estimate: £3,000 - 6,000**

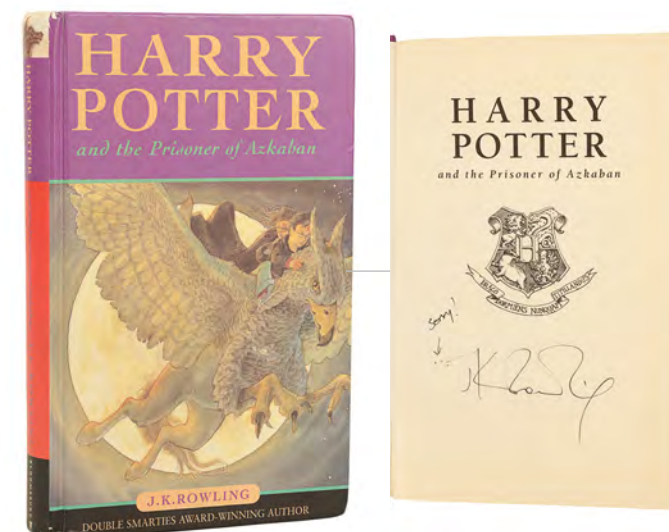

**1219**  
J.K. Rowling-Autographed Hardback Book 1Δ  
**Harry Potter And The Prisoner Of Azkaban (2004)**

A hardback copy of Harry Potter and the Prisoner of Azkaban, the third book in J.K. Rowling's seven-part Harry Potter series, autographed by the author. Published by Bloomsbury, this 8th print run hardback has its title page autographed in black ink by Rowling, who has also written "sorry!" with an arrow pointing to a small hole she made in the page while signing. Random words in the book's text are highlighted, and some pages have been scribbled on with various pens. The lot is accompanied by a certificate of authenticity and additional information from Harry Potter specialist Adam Houston. Dimensions: 20.5 cm x 13.5 cm x 2.5 cm (8" x 5.25" x 1") The autographs in this lot have been professionally authenticated by expert Garry King; see notice in the Buyer's Guide.

**Estimate: £800 - 1,600**

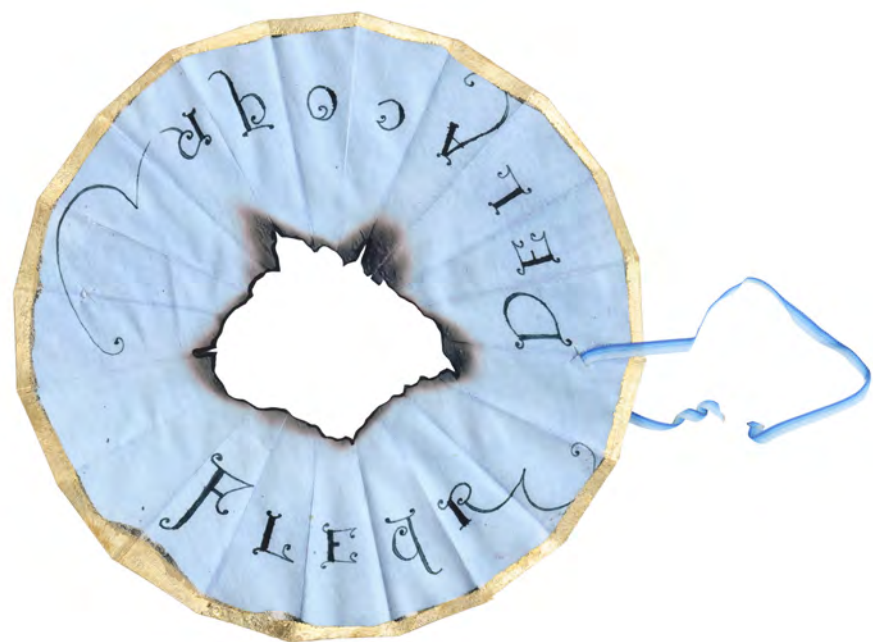

**1220**  
Fleur Delacour's (Clemence Poesy) Goblet of Fire Entry Parchment m  
**Harry Potter And The Goblet Of Fire (2005)**

Fleur Delacour's (Clemence Poesy) Goblet of Fire entry parchment from David Yates' fantasy adventure sequel Harry Potter and the Goblet of Fire. Fleur put her name into the Goblet of Fire in hope of being selected for the Triwizard Tournament, and the Goblet selected her by spitting it back out, for Dumbledore to catch and read aloud. The parchment is made of light blue paper with a gold-coloured edge, cut into a circle and folded in a concertina arrangement. It features a deliberate hole at the centre, around which it has been printed to appear burnt. "Fleur Delacour" is printed in elegant script on the surface of the paper, and blue ribbon is threaded through one edge.

Dimensions: 15.5 cm x 15.5 cm (6" x 6")

**Estimate: £2,000 - 4,000**



**1221**  
Quidditch World Cup Programme m  
**Harry Potter And The Goblet Of Fire (2005)**

A Quidditch World Cup programme from Mike Newell's 2005 fantasy film Harry Potter and the Goblet of Fire, the fourth instalment of the Harry Potter film series. Attendees at the Quidditch World Cup Final carried programmes with them containing key information about the upcoming game. The programme's inner features feature information on sponsors, an introduction to the Quidditch World Cup, tickets to the event, team profiles for Ireland and Bulgaria, and team formations. The front reads "The International Quidditch Association presents the 422nd Quidditch World Cup programme", with a Quidditch logo on the back page. The programme is made of plastic, whilst the inner pages are paper.

Dimensions: 27 cm x 12 cm (10.75" x 4.75")

**Estimate: £700 - 1,400**



**1222**  
"Bulgaria vs Ireland" Daily Prophet Newspaper Cover m  
**Harry Potter And The Goblet Of Fire (2005)**

A "Bulgaria vs Ireland" Daily Prophet newspaper cover from David Yates' fantasy adventure sequel Harry Potter and the Goblet of Fire. Crowds gathered to see the Quidditch World Cup final and read the Daily Prophet article about the match prior to its beginning. The headline on the newspaper reads "Quidditch World Cup Bulgaria vs Ireland" The pages within are blank, and the article on the front page is populated with filler text. Printed on the back are various puzzles. The paper is folded in four, and exhibits some tearing along the edges, as well as minor staining. Otherwise, it remains in good condition. Dimensions: 49 cm x 30 cm (19.25" x 12")

**Estimate: £750 - 1,500**



**1223**  
O.W.L. Examination Paper m  
**Harry Potter And The Order Of The Phoenix (2007)**

An O.W.L. examination paper from David Yates' fantasy-adventure sequel Harry Potter and the Order of the Phoenix. Ordinary WIZARDING LEVEL (O.W.L.) subject papers were used during an exam in the great hall when Fred (James Phelps) and George Weasley (Oliver Phelps) launched a firework display targeting Dolores Umbridge (Imelda Staunton). The test is printed on thin paper, and the subject for this exam is "Theory of Charms - Part I B/X". Eleven questions are displayed within boxes in the top half, and the lower section is labelled as a "Continuation Sheet". The test exhibits fold lines and should be handled carefully as the paper is fragile.

Dimensions: 34 cm x 22 cm (13.25" x 8.5")

**Estimate: £500 - 1,000**



**1224**  
'Dumbledore: Daft or Dangerous' Daily Prophet Newspaper Display Cover m  
**Harry Potter And The Order Of The Phoenix (2007)**

A Daily Prophet "Dumbledore: Daft or Dangerous" newspaper display from David Yates' fantasy-adventure sequel Harry Potter and the Order of the Phoenix. Cornelius Fudge's (Robert Hardy) wizarding world newspaper, the Daily Prophet, ran stories discrediting Dumbledore (Michael Gambon) over Voldemort's (Ralph Fiennes) return. The headline display was prominently featured on the news stand that was seen by Harry (Daniel Radcliffe) on his way to the Ministry of Magic at the beginning of the film. The headline reads "Dumbledore: Daft or Dangerous?", on a Daily Prophet branded sheet. Dimensions: 57 cm x 36 cm (22.5" x 14.25")

**Estimate: £1,000 - 2,000**

**1225**  
Prophecy Orb m  
**Harry Potter And The Order Of The Phoenix (2007)**

A prophecy orb from David Yates' fantasy adventure sequel Harry Potter and the Order of the Phoenix. Prophecy orbs were kept in the Hall of Prophecy, a chamber within the Ministry of Magic where Harry Potter (Daniel Radcliffe) and his companions fought Death Eaters. The prophecy orb is made of clear acrylic and contains wool and fibres, which may have been used to create the swirling, cloudy effect seen in the film. The orb opens down the centre, and aside from being dusty it is in very good condition. Dimensions: 7 cm x 7 cm x 7 cm (2.75" x 2.75" x 2.75")

**Estimate: £3,000 - 6,000**



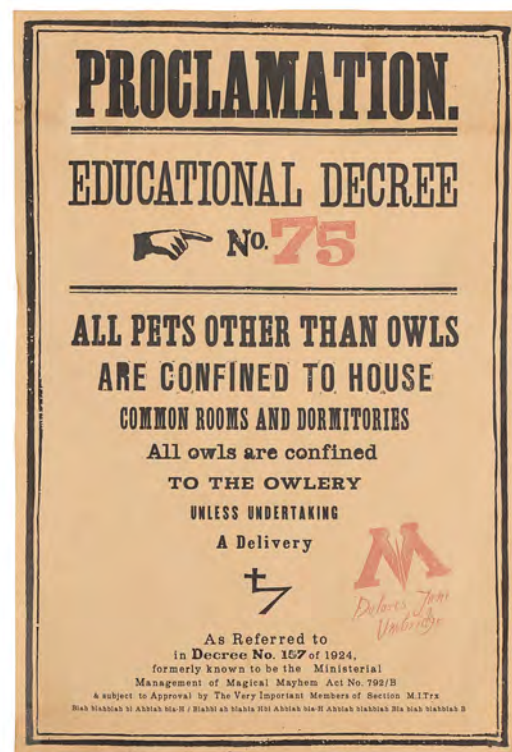

**1226**  
Proclamation No. 75 m  
**Harry Potter And The Order Of The Phoenix (2007)**

A "Proclamation No. 75" from David Yates' fantasy adventure sequel Harry Potter and the Order of the Phoenix. Various numbered proclamations were nailed to the walls of Hogwarts during Dolores Umbridge's (Imelda Staunton) reign as headmistress, each of which issued strict rules to students. This proclamation reads, "PROCLAMATION. EDUCATIONAL DECREE NO. 75. All pets other than owls are confined to house common rooms and dormitories. All owls are confined to the owlery unless undertaking a delivery". It features Umbridge's signature, and is printed on deliberately aged paper. Dimensions: 37 cm x 25 cm (14.5" x 10")

**Estimate: £1,500 - 3,000**

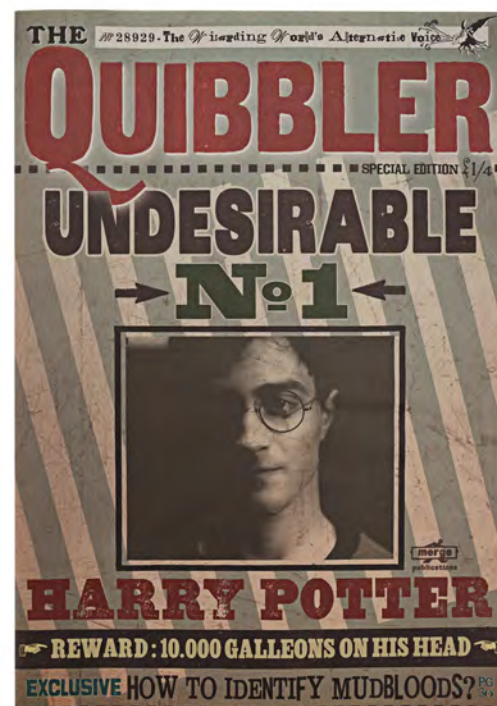

**1227**  
"Undesirable" The Quibbler Magazine Cover m  
**Harry Potter And The Order Of The Phoenix (2007)**

An "Undesirable" The Quibbler magazine from David Yates' fantasy adventure film Harry Potter and the Half-Blood Prince.

Though not obviously seen on screen, various editions of the Quibbler magazine decorated the home of Xenophilius Lovegood (Rhys Ifans), Luna Lovegood's (Evanna Lynch) father, when Harry (Daniel Radcliffe), Ron (Rupert Grint), and Hermione (Emma Watson) went to visit to ask after a symbol they had seen him wearing. Posters and magazines had begun to circulate declaring Harry Potter "Undesirable No. 1" after the Ministry of Magic was overtaken by Death Eaters. The magazine offers a 10,000 galleon reward for Potter. The articles within are printed on insert pages and populated with filler text. Dimensions: 34 cm x 24 cm (13.5" x 9.5")

**Estimate: £1,000 - 2,000**

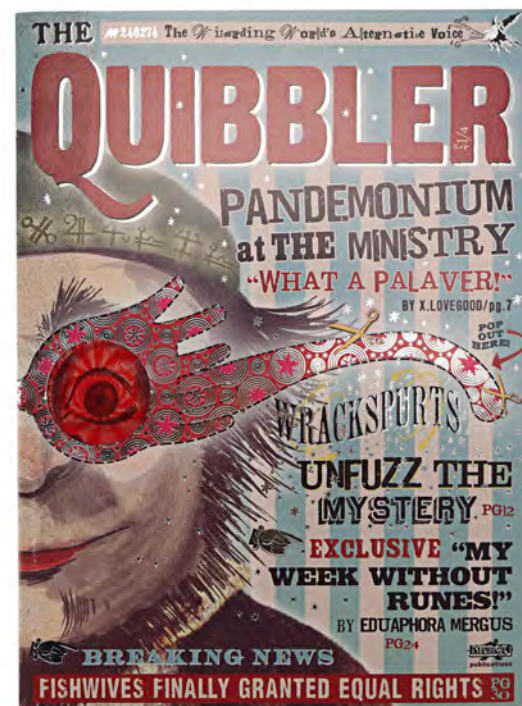

**1228**  
"Pandemonium at the Ministry" The Quibbler Magazine Cover with "Spectrespecs" m  
**Harry Potter And The Order Of The Phoenix (2007)**

A "Pandemonium at the Ministry" The Quibbler magazine cover with a pair of "Spectrespecs" from David Yates' fantasy adventure sequel Harry Potter and the Half-Blood Prince. Luna Lovegood (Evanna Lynch) was reading a copy of The Quibbler when she found Harry (Daniel Radcliffe) on the Hogwarts Express after he had been petrified by Draco Malfoy (Tom Felton). The "Spectrespecs" from the magazine allowed her to see through Harry's invisibility cloak. This copy of The Quibbler has a colourful pair of "Spectrespecs" attached to its cover via a perforated seam, making them detachable. The articles within contain filler text. Dimensions: 27 cm x 20 cm (10.75" x 8")

**Estimate: £2,500 - 5,000**



7 cm (2.75")

**1229**  
Heartbreak Teardrops Potion Bottle m  
**Harry Potter And The Half-Blood Prince (2009)**

A Heartbreak Teardrops potion bottle from David Yates' fantasy adventure sequel Harry Potter and the Half-Blood Prince. Heartbreak Teardrops were one of several potions in the WonderWitch line sold at Weasleys' Wizard Wheezes, the Weasley Brothers' joke shop visited by Harry Potter (Daniel Radcliffe) and his friends. The bottle is made of pink glass, with a removable heart-shaped plastic stopper and a pink ribbon tied around its neck. It features a number of labels, including one bearing the WonderWitch branding, and another which reads "Heartbreak Teardrops no. 281". The bottle does not contain any liquid. The labels show some fading from age, but otherwise the item remains in very good condition. Dimensions: 7 cm x 4 cm x 4 cm (2.75" x 1.5" x 1.5")

**Estimate: £2,000 - 4,000**



**1230**  
Butterbeer and Mulled Mead Bottles m  
**Harry Potter And The Half-Blood Prince (2009)**

Butterbeer and Mulled Mead bottles from David Yates' fantasy adventure sequel Harry Potter and the Half-Blood Prince. Drinks bottles were seen in the Three Broomsticks Inn, the tavern in the village of Hogsmeade, where Harry (Daniel Radcliffe), Hermione (Emma Watson) and Ron (Rupert Grint) sat and talked with Professor Slughorn (Jim Broadbent). These rare items are green glass bottles with printed labels, intentionally distressed to look aged. Each has some tears on its labels and some adhesive residue. Dimensions (Butterbeer bottle): 22 cm x 6 cm x 6 cm (8.75" x 2.25" x 2.25")

**Estimate: £4,000 - 8,000**

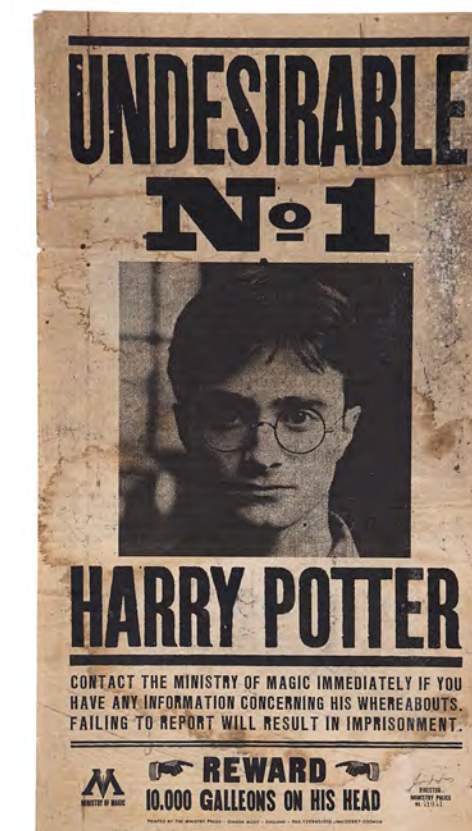

**1231**  
"Undesirable No.1" Poster m  
**Harry Potter And The Deathly Hallows: Part 1 (2010)**

An Undesirable No. 1 poster from David Yates' fantasy film Harry Potter and the Deathly Hallows: Part 1. When the Ministry of Magic was overtaken by the Death Eaters and Pius Thicknesse (Guy Henry) became Minister for Magic, he decreed that Harry Potter (Daniel Radcliffe) was a most wanted individual, labelling him Undesirable No. 1 and putting up posters seeking information concerning his whereabouts. Such posters can be seen across the walls of Diagon Alley. The paper has been deliberately weathered. Dimensions: 58 cm x 35 cm (23" x 13.75")

**Estimate: £1,500 - 3,000**



**1232**  
**Set of Three Floating Lovegood House Plumbs †Δ**  
**Harry Potter And The Deathly Hallows: Part 1 (2010)**

Set of three dirigible plums from David Yates' fantasy adventure sequel Harry Potter and the Deathly Hallows: Part 1. Xenophilius Lovegood (Rhys Ifans) grew a dirigible plum bush outside his home. These plums are orange, radish-like magical fruits, which grow upside down. The three variously sized plums are made of plastic, and attached to each other by a thin, clear plastic cord, from which they would have been hung on set. Each plum features a flexible stem made of green rubber. The plums exhibit some scuffing, and the cord that connects them is tangled, but otherwise they remain in very good condition. Dimensions: 15 cm x 9 cm x 18 cm (6" x 3.5" x 7")

**Estimate: £800 - 1,600**

**1233**  
**Pair of Gringotts Gold Bars †Δ**  
**Harry Potter And The Deathly Hallows: Part 1 (2010)**

A pair of Gringotts gold bars from David Yates' fantasy adventure sequel Harry Potter and the Deathly Hallows: Part 1. The vaults of Gringotts Wizarding Bank were filled with gold bars when Harry (Daniel Radcliffe), Hermione (Emma Watson) and Ron (Rupert Grint) went in search of one of Voldemort's horcruxes. Each bar is a different size, but both are made of plastic and moulded with a Gringotts logo and serial number. Both exhibit surface scratches and splits in the plastic, but otherwise remain in good condition. Dimensions: 19 cm x 9 cm x 8 cm (7.5" x 3.5" x 3.25")

**Estimate: £800 - 1,600**



**1234**  
**Destroyed Covered Wooden Bridge Part †Δ**  
**Harry Potter And The Deathly Hallows: Part 2 (2011)**

A destroyed bridge section from David Yates' fantasy adventure Harry Potter and the Deathly Hallows: Part 2. During the Battle of Hogwarts, the Snatchers tried to cross the Wooden Bridge in order to gain access to Hogwarts Castle. Neville Longbottom (Matthew Lewis) blew up the bridge, sending Scabior (Nick Moran) and many Snatchers to their deaths. The destroyed bridge part is made of polystyrene foam, painted brown with a grain effect to resemble engraved wood. It comprises a circular frame set within the remnants of tripartite arches. At the centre of the frame are facial features, around which are several curved ridges that extend into ornate patterned curls. The lot is intentionally distressed. Dimensions: 78.5 cm x 59 cm x 7 cm (31" x 23.25" x 2.75")

**Estimate: £400 - 800**

**1235**  
**Stunt Hufflepuff Cup Horcrux †Δ**  
**Harry Potter And The Deathly Hallows: Part 2 (2011)**

A stunt Hufflepuff Cup Horcrux from David Yates' fantasy-adventure sequel Harry Potter and the Deathly Hallows: Part 2. Harry (Daniel Radcliffe) infiltrated Bellatrix Lestrange's (Helena Bonham Carter) Gringotts vault to acquire the Huffle Cup, one of Voldemort's (Ralph Fiennes) Horcruxes, before Hermione (Emma Watson) and Ron (Rupert Grint) later destroyed it with a basilisk tooth. This stunt version is made of rubber with a gold-coloured finish and features the same decorative engravings as the hero version, including the Hufflepuff badger. A stunt version was likely used when Griphook (Warwick Davis) tossed the cup to Hermione in exchange for the sword of Gryffindor. The cup she caught resembles this stunt version, as opposed to the hero version, which is made of metal with a different gold-coloured tone. Dimensions: 6.75 cm x 10.5 cm x 13.25 cm (2.75" x 4.25" x 5.25")

**Estimate: £3,000 - 6,000**



**1237**  
**Exam Paper, Ministry of Magic Documents, Gringotts Rune Credit Note and Quibbler Magazine †Δ**  
**Harry Potter And The Order Of The Phoenix (2007)/**  
**Harry Potter And The Deathly Hallows: Part 1 (2010)**

An exam paper, a Gringotts Rune credit note and a copy of Quibbler magazine from David Yates' fantasy adventure sequel Harry Potter and the Order of the Phoenix, accompanied by Ministry of Magic documents from Harry Potter and the Deathly Hallows: Part 1. Exam papers were seen on the desks of Harry Potter (Daniel Radcliffe) and his peers as they sat their O.W.L.s in the Great Hall. Luna Lovegood (Evanna Lynch) was seen reading her father's Quibbler magazines throughout the film. The Ministry of Magic documents are a dossier on Elicia Scales, a witch the Death Eaters were keeping tabs on. All the items in this lot are made of paper. Exam papers are the only item in this lot obviously seen on screen, while the others were made to contribute to the set design. The exam paper has a crumpled top right corner. Dimensions (Quibbler): 34.5 cm x 24.25 cm (13.5" x 9.5")

**Estimate: £2,000 - 4,000**

**1236**  
**Quidditch World Cup Programme with Pair of "You-Know-Who Claims Another Victim" and "Harry in Hiding" The Quibbler Newspaper Covers †Δ**  
**Harry Potter And The Goblet Of Fire (2005)/Harry Potter And The Deathly Hallows: Part 1 (2010)**

A Quidditch World Cup programme from Mike Newell's fantasy adventure sequel Harry Potter and the Goblet of Fire, with a pair of "You-Know-Who Claims Another Victim" and "Harry in Hiding" The Quibbler newspaper covers from David Yates' sequel Harry Potter and the Deathly Hallows: Part 1. In The Goblet of Fire, fans attending the Quidditch World Cup final carried programmes. In The Deathly Hallows: Part 1, issues of The Quibbler were seen in the home of Xenophilius Lovegood (Rhys Ifans) when Harry (Daniel Radcliffe) and his friends visited the wizarding tabloid's publisher to learn about the Deathly Hallows. All three documents are made from paper. The programme is similar to football matchday programmes, featuring information and pre-game build-up material. Each copy of The Quibbler contains advertisements, while the copy headlined "You-Know-Who" features a pull-out section with articles surrounding wizarding issues and debates. Dimensions (one copy of The Quibbler): 34 cm x 24.25 cm (13.5" x 9.5")

**Estimate: £2,000 - 4,000**



**1238**  
 Grand Staircase Lamp Model Miniature and  
 Clapperboard Slate †  
**Harry Potter And The Philosopher's Stone (2001)/**  
**Harry Potter And The Goblet Of Fire (2005)**

A Grand Staircase lamp model miniature from Chris Columbus' fantasy adventure Harry Potter and the Philosopher's Stone, and a clapperboard slate from Mike Newell's sequel Harry Potter and the Goblet of Fire. The Grand Staircase's magical ability to move made it one of Hogwarts' most memorable features. This miniature metal staircase lamp has translucent plastic panels designed to appear as glass, and an electrical wire that was once used to power it. The clapperboard slate features The Goblet of Fire's codename "Happy Days" carved into its acrylic surface. Despite the film being released in 2005, "3.9.08" is handwritten in black marker pen at the bottom of the slate, indicating that it was used again for a subsequent production. The small size of the clapperboard suggests it was used for insert shots. The lamp exhibits a minor crack in one of its plastic panels. Dimensions: 43.5 cm x 10 cm x 8 cm (17.25" x 4" x 3.25") Contains electronics; see electronics notice in the Buyer's Guide.



**Estimate: £1,500 - 3,000**

**1239**  
 Premiere Gifts, Wand and Wand Box M  
**Harry Potter And The**  
**Philosopher's Stone (2001)**

Premiere gifts from the 2001 premiere of Chris Columbus' fantasy film Harry Potter and the Philosopher's Stone. Included in this lot are an Ollivander's wand, bag and wand box, as well as the invitation to the premiere. The wand is made of wood, with diamond-shaped detailing up at the shaft and a twisted detail around the handle with a tag attached that reads "134." The box, which was also a prop used in the film, is sealed shut, and has an Ollivander's sticker affixed to the top. The bag is made of brown paper with a rainbow ribbon handle and a gold Ollivander's logo printed on the front. The invite is for the world premiere of the film, which took place in London on 4th November 2001. Dimensions: 36 cm x 10 cm x 7 cm (14.25" x 4" x 2.75")

**Estimate: £2,000 - 4,000**



**1240**  
 Two Hogwarts Plaques and Plaster Hippogriff Maquette †  
**Harry Potter Franchise (1997-2007)**

A pair of Hogwarts plaques and a plaster Hippogriff maquette from the film series adaptation of J.K. Rowling's Harry Potter franchise. Buckbeak the Hippogriff played a significant role in the third instalment of the franchise, Harry Potter and the Prisoner of Azkaban. The white plaster hippogriff head was created in the design process when the production was completing the aesthetic of Buckbeak. The fibreglass plaques, painted to look like metal, were made to form part of the Hogwarts' set. The plaques exhibit wear in the form of peeling. Dimensions: 35.5 cm x 22.5 cm x 15 cm (14" x 8.75" x 6")

**Estimate: £1,000 - 2,000**



**1241**  
 Set of Three Gringotts Bank Coins M  
**Harry Potter Series (2001 - 2011)**

A set of three Gringotts bank coins from the Harry Potter franchise. Gringotts coins were seen in many of the films, notably the first instalment, Harry Potter and the Philosopher's Stone, when Harry (Daniel Radcliffe) visited the bank with Hagrid (Robbie Coltrane) and discovered the fortune his parents had left him. These plastic coins represent gold galleons, with the other two denominations of wizarding money being bronze knuts and silver sickles. Dimensions: 4 cm x 4 cm x 0.5 cm (1.5" x 1.5" x 0.25")

**Estimate: £1,000 - 2,000**

**1242**  
 Daniel Radcliffe-Autographed Stills and Crew Items M  
**Harry Potter Series (2001 - 2011)**

Three large printed stills autographed by Daniel Radcliffe and a collection of crew items from the production of the Harry Potter franchise. The three stills depict a different angle of Harry's cross-examination by Cornelius Fudge (Robert Hardy) in The Order of the Phoenix. These are autographed in black pen by Radcliffe, addressing Ray Norris, the production's carpenter from the third film to the last. Also included is a limited edition Masterworks print collection from the third film, a boxed crew gift wand, four Hogwarts houses badges, a crew jumper sealed in its original packaging, two crew caps, and a crew bag. Dimensions: 42 cm x 29.75 cm (16.5" x 11.75") The autographs in this lot have been professionally authenticated by expert Garry King; see notice in the Buyer's Guide.

**Estimate: £500 - 1,000**



**1243**  
 Daniel Radcliffe-autographed Crew Bag  
 and Collection of Crew Gear M  
**Harry Potter Series (2001 - 2011)**

A Daniel Radcliffe autographed crew bag and collection of crew gear from the production of the Harry Potter film series. This lot comprises five T-shirts, one jumper and a satchel-style bag. A black T-shirt (size "M") has "Harry Potter Stunt Crew 2000" printed on the front and the Stuntsworldwide logo on the back; a blue T-shirt ("Large") features the Quidditch logo printed on the front and "HP Crew" on the back; a green T-shirt has the Hogwarts logo printed on the front and "HP Crew" on the back; a long-sleeved T-shirt ("M") features "Chamber of Secrets Quidditch VFX Crew" printed on the front and "Potter 02" on the back; another black T-shirt ("2 XL") features "HP VFX Crew" printed on the front and a dragon design on the back. The jumper has "HP Crew" embroidered on the left sleeve, and the clothing label reads "Harry Potter and the Philosopher's Stone". The bag is embossed with a Harry Potter logo and has a metal Hogwarts insignia affixed to its front. Radcliffe, who played Harry, has autographed the bag in gold ink. The autographs in this lot have been professionally authenticated by expert Garry King; see notice in the Buyer's Guide.

**Estimate: £500 - 1,000**



**1244**  
Death Eater Dark Mark Clay Sculpt and Unused Mark m  
**Harry Potter Series (2001 - 2011)**

A Death Eater Dark Mark clay sculpt and an unused Mark from the production of the Harry Potter film series. Each Death Eater had a Dark Mark - a form of magical branding - which they could use to summon their leader, Voldemort (Ralph Fiennes). The sculpt is made of clay and adhered to a piece of plastic. It is presented beside an unused colourised Dark Mark, reminiscent of the one seen floating in the sky after the Death Eater attack at the Quidditch World Cup in the fourth film. Dimensions: 21.25 cm x 13.25 cm x 0.5 cm (8.5" x 5.25" x 0.25")

**Estimate: £500 - 1,000**



**1245**  
King Henry V's  
(Kenneth Branagh) Costume +  
**Henry V (1989)**

Henry V's (Kenneth Branagh) costume from Kenneth Branagh's 1989 Shakespeare adaptation Henry V. Henry wore his costume for much of the film, including his iconic "Once more unto the breach" speech. The costume comprises a grey undershirt; a long-sleeved leather tunic; a leather collar; a pair of trousers; a red-and-blue overtunic; two belts; and a pair of boots. Several items feature internal labels from Bermans & Nathans, including "Kenneth Branagh 11030 Henry V A H 77655" in the leather tunic; and "Kenneth Branagh 11030 Costume 2 Henry V" in the overtunic. Handwritten inside one of the boots is "Mr Branagh 8 1/2", while handwritten labels on the belts read "BBC 3" and "Angles [sic]". One of the belts is cracked, and the overtunic exhibits some discolouration due to age, but otherwise the costume remains in very good condition.

**Estimate: £1,500 - 3,000**



**1246**  
Limited Edition Collection of  
Photographs m  
**Highlander (1986)**

A limited edition collection of photographs from the production of Russell Mulcahy's action-fantasy Highlander. Film photographer David James was commissioned by EMI Screen Entertainment to compile 500 limited sets of 15 prints. These black-and-white prints depict unique angles of main characters, including Connor MacLeod (Christopher Lambert), the Kurgan (Clancy Brown) and Ramirez (Sean Connery). Included is a certificate of authenticity signed by James. The box the photographs are contained in exhibits scuffs at the edges. Dimensions (one photograph): 40.75 cm x 30 cm (16" x 11.75")

**Estimate: £600 - 1,200**



**1247**  
Christopher Lambert-autographed  
MacLeod Sword Replica m  
**Highlander (1986)**

A Christopher Lambert-autographed replica of the sword wielded by the immortal Connor MacLeod (Christopher Lambert) in Russell Mulcahy's cult action sci-fi movie Highlander. Made under license in Spain by Marto Swords, this is a limited-edition piece numbered "H9534". The metal blade has been autographed by Lambert in black ink and inscribed with the famous, much-quoted line "There can be only one!". Dimensions: 110 cm x 23 cm x 4 cm (43.25" x 9" x 1.5") The autographs in this lot have been professionally authenticated by expert Garry King; see notice in the Buyer's Guide.

**Estimate: £800 - 1,600**

**1248**  
Shooting Script and Behind-the-Scenes Photos m  
**Highlander (1986)**

A shooting script and collection of behind-the-scenes photographs from the production of Russell Mulcahy's action fantasy Highlander. The full-length script is 199 pages, some of which are pink. The seven behind-the-scenes photographs predominantly depict The Kurgan (Clancy Brown) in different costumes and makeup test appliances. Dimensions: 28 cm x 21.5 cm x 1.5 cm (11" x 8.5" x 0.5")

**Estimate: £800 - 1,600**



**1249**  
Christopher Lambert and Clancy  
Brown Autographed UK Quad m  
**Highlander (1986)**

A Christopher Lambert and Clancy Brown autographed UK Quad poster for Russell Mulcahy's action fantasy Highlander. Christopher Lambert, who played Connor MacLeod, has autographed the poster in silver marker pen, while Clancy Brown, who played The Kurgan, has autographed it in gold marker pen. Both actors have handwritten the quote "There can be only one". The poster was released to promote the film's return to cinemas in 2016 to celebrate its 30th anniversary and also its restoration in 4K. Dimensions: 101.5 cm x 76.25 cm (40" x 30") The autographs in this lot have been professionally authenticated by expert Garry King; see notice in the Buyer's Guide.

**Estimate: £500 - 1,000**





**1250**  
Clan MacLeod Kilt +  
**Highlander (1986)**

Clan MacLeod kilt from Russell Mulcahy's fantasy film Highlander. Members of Clan MacLeod wore blue tartan kilts and shawls as a marker of their allegiance. Included in this lot are two kilts and one shawl, all in blue tartan. One of the kilts is double-layered, one only single layered. A label in the single-layered kilt reads "3261 Highlander". Each of the three items features a deliberately patched look, and fasten via fabric ties.

**Estimate: £800 - 1,600**



**1251**  
Clan MacLeod Banner m  
**Highlander (1986)**

A Clan MacLeod banner from Russell Mulcahy's fantasy action-adventure Highlander. Clan MacLeod carried their banners into battle against Clan Fraser at the film's beginning. The red banner features three black bulls heads stitched onto it and metal eyelets where it attached to a pole. The banner has been intentionally distressed. Dimensions: 104 cm x 33 cm (41" x 13")

**Estimate: £1,000 - 2,000**

**1252**  
Marvin Crew Gift m  
**The Hitchhiker's Guide To The Galaxy (2005)**

A Marvin crew gift from the production of Garth Jennings' 2005 sci-fi comedy film The Hitchhiker's Guide to the Galaxy. Marvin, a clinically depressed robot, was a member of the crew of the stolen starship Heart of Gold. The model was gifted to a head of department on the film, and was moulded from the original art department maquette. It is made of resin, painted with a white pearlescent finish, with black hands and joints, and green eyes. It comes displayed on a custom silver base. Dimensions: 25 cm x 20 cm x 17 cm (10" x 8.25" x 6.75")

**Estimate: £500 - 1,000**

**1253**  
Old Bilbo Baggins' (Ian Holm)  
Silicone Hobbit Ear Prosthetics +Δ  
**The Hobbit: An Unexpected Journey (2012)**

Old Bilbo Baggins' (Ian Holm) silicone hobbit ear prosthetics from Peter Jackson's epic fantasy film The Hobbit: An Unexpected Journey. All the hobbit ears that appear in the Lord of the Rings prequel trilogy were custom-made by Weta Workshop to securely fit each performer. These large silicone ears are hand-painted pink and peach to resemble skin, and come mounted on two plaster bases engraved "Old Bilbo". The right ear exhibits a small tear, and the slightly adhesive nature of the silicone means that both ears have attracted lint. Dimensions (one ear): 14.5 cm x 10 cm x 2 cm (6" x 4" x 1")

**Estimate: £1,000 - 2,000**

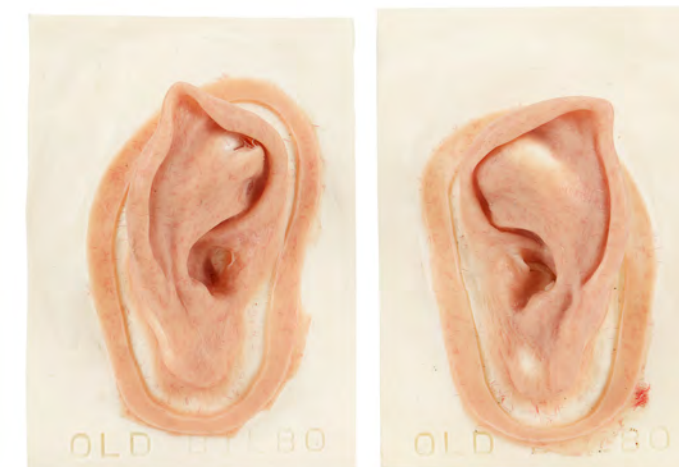

**1254**  
Erebor Dwarf Pillar Model Miniature m  
**The Hobbit: An Unexpected Journey (2012)**

An Erebor dwarf pillar model miniature from Peter Jackson's fantasy-adventure prequel The Hobbit: An Unexpected Journey. Pillars depicting dwarf soldiers were seen on the walls of Erebor as the dragon Smaug violently invaded Lonely Mountain. This pillar is made of hard foam, finished to look like stone with gold trim. Dimensions: 75 cm x 34 cm x 9 cm (29.5" x 13.5" x 3.5")

**Estimate: £1,000 - 2,000**



**1255**  
Fili-style Set Dressing Sword m  
**The Hobbit: The Battle Of The Five Armies (2014)**

A Fili-style set dressing sword from Peter Jackson's fantasy-adventure prequel The Hobbit: The Battle of the Five Armies. Weta Workshop, the special effects and prop company which also worked on The Lord of the Rings trilogy, produced swords and other weapons that appeared in Erebor's weapon chamber. This sword is cast from the hero sword of the dwarf character Fili (Dean O'Gorman). The sword is made of hard rubber with a metal armature. It is painted to look like metal. Dimensions: 116 cm x 17.75 cm x 4 cm (45.75" x 7" x 1.5")

**Estimate: £1,500 - 3,000**



**1256**  
Kili (Aidan Turner)-style  
Set Dressing Sword **M**  
**The Hobbit: The Battle Of The Five  
Armies (2014)**

A set dressing sword in the style of Kili (Aidan Turner) from Peter Jackson's fantasy-adventure prequel *The Hobbit: The Battle of the Five Armies*. Swords and other weapons appeared in the dwarf's stronghold, Erebor. This sword was cast by Weta Workshop, the special effects and prop company which also worked on *The Lord of the Rings* trilogy, from Kili's hero sword, although it was painted differently for use as set dressing in Erebor. Its handle, for example, is painted brown rather than the blue of Kili's sword. The sword is made of hard rubber with a metal armature. It is painted to look like metal, while the hilt's grip is constructed and painted to look like leather straps. Dimensions: 100 cm x 11 cm x 5.5 cm (39.25" x 4.25" x 2.25")

**Estimate: £2,000 - 4,000**



**1257**  
Richard III's  
(Benedict Cumberbatch) Armour **1A**  
**The Hollow Crown (T.V. Series,  
2012-2016)**

Richard III's (Benedict Cumberbatch) armour from the third episode of the second series of the BBC mini-series *The Hollow Crown*, titled "Richard III". Richard III wore his armour to deliver a speech to his army prior to battle. The armour is made of polyurethane, with the exception of a chainmail shirt that layers beneath it, which is made of metal. It fastens together via leather straps, and some of the pieces are leather-lined. The armour was made to fit Cumberbatch's natural body, with no allowance made in the breastplate for the character's deformity. The helmet is padded with foam for the comfort of the wearer. The armour exhibits some scuffing and wear from production use.

**Estimate: £3,000 - 6,000**



**1258**  
"Wet Bandits Escape" Newspaper **Ω**  
**Home Alone 2: Lost In New York  
(1992)**

A "Wet Bandits Escape" newspaper from Chris Columbus' Christmas comedy film *Home Alone 2: Lost in New York*. A torn *Chicago Sun-Times* newspaper ominously blew onto the McCallister porch the night before Kevin's (Macaulay Culkin) unplanned trip to the Big Apple. Printed on tabloid sized newspaper stock paper, the *Chicago Sun-Times* features the bold headline "'Wet Bandits' escape during prison riot" and shows mugshots of the dishevelled Harry (Joe Pesci) and Marv (Daniel Stern), following their painful encounter with Kevin in the previous film. The front page features two articles, one titled "Police warn of holiday break-ins", and the other "Local manhunt ensues". The text for each article is pasted from an unrelated news story. The back cover of the newspaper is the "Sports Wednesday" section, and covers various sports headlines. Dimensions: 37.5 cm x 29 cm (14.75" x 11.5")

**Estimate: £2,000 - 4,000**



**1259**  
Kevin McCallister's (Macaulay Culkin) Production-Made  
Monster Sap Can **Ω**  
**Home Alone 2: Lost In New York (1992)**

Kevin McCallister's (Macaulay Culkin) Monster Sap can from the production of Chris Columbus' *Home Alone 2: Lost in New York*. Kevin used the Monster Sap he bought at Duncan's Toy Chest to set a booby trap for Marv Murchins (Daniel Stern) and Harry Lyme (Joe Pesci). Created by production but ultimately unseen in the final cut, this lot consists of an aluminium can of shaving foam with a plastic cap applied on the outside with a customised green and yellow label with "Monster Sap" printed in purple and additional gibberish text below it in red. Rust on the bottom has opened a hole in the can, and it exhibits staining throughout from age and production use. Dimensions: 5 cm x 5 cm x 18 cm (2" x 2" x 7")

**Estimate: £800 - 1,600**



**1260**  
Reproduction Captain Hook (Dustin Hoffman)  
Hook and Cuff **Ω**  
**Hook (1991)**

A reproduction of Captain Hook's (Dustin Hoffman) hook and cuff from Steven Spielberg's fantasy-adventure film *Hook*. The notorious pirate captain had a large hook attached to his left arm to replace the hand he lost long ago. Created by the film's blacksmith, Tony Swatton, this metal hook is attached to a matching metal hand cover with a handle inside and decorative patterns engraved throughout the exterior, and a black leather lace-up cuff. The interior of the hand cover is engraved "Tony Swatton 2022." The lot exhibits minor imperfections in the metal's groves. Dimensions: 12.75 cm x 12.75 cm x 38.25 cm (5" x 5" x 15")

**Estimate: £2,500 - 5,000**



**1261**  
Production-used Script  
and Paperwork **M**  
**The Horror Of Frankenstein (1970)**

Jimmy Sangster's personal production-used script and other paperwork from the production of his Hammer horror film *The Horror of Frankenstein*. The script, which belonged to the film's writer and director Jimmy Sangster, is credited to Sangster and Jeremy Burnham, dated "27.2.70", and 124 pages long. Some of the pages have been annotated by Sangster. Among the other paperwork are shooting schedules, scene breakdowns, set plans and concept art. The items exhibit some dog-earing and discolouration. Dimensions: 28.5 cm x 24 cm x 2.5 cm (11.25" x 9.5" x 1")

**Estimate: £1,000 - 2,000**



**1262**  
**Jemma's (Jemma Moore)**  
**Screenmatched Glasses M**  
**Host (2020)**



Jemma's (Jemma Moore) screen-matched glasses from Rob Savage's horror Host. Jemma wore her glasses as she and her friends held a seance via Zoom. The glasses match the ones seen on screen throughout the film by the pink patterns adorning the upper rims. These are a pair of vintage Cazal glasses with a metal frame and plastic embellishments such as the temple tips. The glasses are accompanied by a poster, signed by Moore in silver marker, and a letter of authenticity directly from her stating that these are the only pair that appear in the film. The glasses' left-sided temple is bent slightly out of place, but this does not impede their wearability. Dimensions: 14 cm x 13.5 cm x 5.25 cm (5.5" x 5.25" x 2")

**Estimate: £1,000 - 2,000**

**1263**  
**Nicholas Angel's (Simon Pegg) ID and Notebook,**  
**Throwing Pineapple and Aerosol Can M**  
**Hot Fuzz (2007)**

Nicholas Angel's (Simon Pegg) ID and notebook, throwing pineapple and aerosol can from Edgar Wright's action comedy film Hot Fuzz. Angel carried his ID and notebook throughout the film, recording the misdemeanours of various Sandford residents, used an aerosol spray paint can to apprehend an escaping shoplifter, and was pelted with pineapples and other fruits in the climactic supermarket shootout. The pineapple is made of foam rubber, and the aerosol can is made of foam, with a plastic lid. The first 50 pages of the notebook are filled with handwriting in blue ink, most of which is illegible, and one page features a small doodle. The ID card denotes Angel's name, rank, and warrant number, as well as declaring him a "Sandford Constabulary Police Officer". Both the can and the pineapple exhibit paint damage.

Dimensions: 22 cm x 20 cm x 13 cm (8.75" x 7.75" x 5.25")



**Estimate: £800 - 1,600**



**1264**  
**Leland "Buzz" Harley's (Bill Irwin)**  
**Screen-matched Flight Helmet M**  
**Hot Shots! (1991)**

Buzz Harley's (Bill Irwin) screen-matched flight helmet from Jim Abrahams' Hot Shots! Pilot Buzz Harley wore his helmet during the aerial incident that inadvertently led to the death of his co-pilot Dominic "Mailman" Farnham (Ryan Stiles) and psychological problems for Buzz's son Sean "Topper" Harley (Charlie Sheen). Unique wear points on the helmet screen-match to cockpit shots leading up to the death of Farnham. This fibreglass helmet features an adhered brown wrap, a matching visor cover over a dark-tinted visor, black decals reading "Buzz," a nylon chinstrap, and internal ear covers with an audio cord running to them. The finish exhibits cracking and peeling, and any remaining functionality of the electronics is unknown. Contains electronics; see electronics notice in the Buyer's Guide.

**Estimate: £1,500 - 3,000**



**1265**  
**Dr. House's (Hugh Laurie) Cane M**  
**House (T.V. Series, 2004-2012)**

Dr. Gregory House's (Hugh Laurie) cane from the award-winning medical drama series House. House used a variety of canes throughout the show. This simple wooden cane's shaft and tourist-style handle resemble walnut and it has a black rubber ferrule on the tip. Near the tip is a sticker adhered to the shaft, which reads "Official Prop - Do Not Remove", alongside a picture of Dr. House and the series' title. Dimensions: 90 cm x 13 cm x 3.5 cm (35.5" x 5" x 1.25")

**Estimate: £2,000 - 4,000**



**1266**  
**Dr. House's (Hugh Laurie)**  
**Flame Cane M**  
**House (T.V. Series, 2004-2012)**

Dr. Gregory House's (Hugh Laurie) flame cane from the award-winning medical drama series House. House used a variety of canes throughout the show. In "Family", the 21st episode of Season 3, he forced his colleague Dr. Wilson (Robert Sean Leonard) to buy him a flame cane, after Wilson's dog broke his previous one. House used the flame cane until "House's Head", the 15th episode of Season 4, where it was lost in a bus crash. The cane's shaft and curved handle are made from wood that is painted black. Yellow-and-red flame decals adorn the shaft's bottom third, leading down to a black rubber ferrule. The cane comes with a certificate of authenticity from NBC Studios. Dimensions: 108 cm x 13 cm x 4 cm (42.5" x 5" x 1.5")

**Estimate: £3,000 - 6,000**



**1267**  
**Dr. House's (Hugh Laurie) Cane M**  
**House (T.V. Series, 2004-2012)**

Dr. Gregory House's (Hugh Laurie) cane from the award-winning medical drama series House. House used a variety of canes throughout the show. This style was used from Season 2 and periodically appeared again in Seasons 3, 5 and 6. The wooden cane's shaft and handle resemble rosewood and it has a black rubber ferrule on the tip. The lot comes with a certificate of authenticity from NBC Studios. Dimensions: 91 cm x 14 cm x 3.5 cm (35.75" x 5.5" x 1.25")

**Estimate: £2,000 - 4,000**



**1268**  
 Georges Melies' (Ben Kingsley) Screen-Matched  
 SFX Box of Memories  $\pm$   
**Hugo (2011)**

Georges Melies' (Ben Kingsley) screen-matched SFX Box of Memories from Martin Scorsese's family adventure Hugo. This box screen-matches the one that throws paper everywhere after Isabelle (Chloë Grace Moretz) drops it on the floor, through distinctive markings on its front. The box is made predominantly of biscuit foam painted to look like wood, with wood on the inside for structural purposes. It features an interior mechanism which, when activated by a cord running from the side of the box, would have thrown the paper into the air, although some of the mechanism has since been removed. Dimensions: 32 cm x 43.5 cm x 22 cm (12.5" x 17" x 8.75") Contains electronics; see electronics notice in the Buyer's Guide.

**Estimate: £400 - 800**



**1269**  
 Jack Ryan's (Alec Baldwin) Navy Uniform Jacket  $\Omega$   
**The Hunt For Red October (1990)**

Jack Ryan's (Alec Baldwin) Navy uniform jacket from John McTiernan's The Hunt for Red October. Ryan wore his Navy uniform jacket as he arrived at the USS Enterprise naval ship on the North Atlantic coast where he met with Rear Admiral Joshua Painter (Fred Thompson). This lot consists of a black polyester-wool jacket featuring gold-colour trim, star patches, and gold-colour metal buttons labelled "44 LNG 0497" and marked "A. BALDWIN" on the interior pocket.

**Estimate: £1,500 - 3,000**



**1270**  
 Ramona Vega's (Jennifer Lopez) Dress and Jewellery  $\mathfrak{M}$   
**Hustlers (2019)**

Ramona Vega's (Jennifer Lopez) dress and jewellery from Lorene Scafaria's crime comedy-drama Hustlers. Ramona wore her dress as she and Destiny (Constance Wu) discussed the future of their operation. The black Balmain dress (size 38) has a deep V-neck plunge, glittery silver thin threading and it zips up the back. The three bracelets are silver and decorated with faux diamonds.

**Estimate: £2,000 - 4,000**

**1271**  
 Set Design and Sketches  $\mathfrak{M}$   
**If... (1968)**

Hand-drawn set design sketches from the production of Lindsay Anderson's satirical drama film If... Included in this lot are four designs, rendered in mixed media and mounted to cardboard frames. The sketches include Johnny's study; a dinner meeting between Mr Kemp, the Housemaster, Mrs Kemp and the 'Whips'; the bedroom of Mr and Mrs Kemp, in which Mr Kemp is singing, accompanied by Mrs Kemp on the recorder; and Mick's study, with Johnny climbing in through the window. The sketches of the dinner meeting and the Kemps' bedroom are both signed "O.K. LGA" on the sketch mounts - the signature of director Lindsay Gordon Anderson. A second signature on the dinner meeting sketch is unidentified. Dimensions: 51 cm x 71 cm x 1 (20" x 28" x 0.5") Sold without copyright; see copyright notice in the Buyer's Guide.

**Estimate: £500 - 1,000**



**1272**  
 Commander Denniston's (Charles Dance) and  
 Alan Turing's (Benedict Cumberbatch) Costumes  $\mathfrak{M}$   
**The Imitation Game (2014)**

Commander Denniston's (Charles Dance) and Alan Turing's (Benedict Cumberbatch) costumes from Morten Tyldum's 2014 biopic The Imitation Game. Commander Denniston wore his military uniform while recruiting Alan Turing (Benedict Cumberbatch) to the cryptography team at Bletchley Park, and Turing wore elements of his costume while out with other members of the team. Denniston's costume consists of a jacket, trousers, braces and a pair of shoes. "Waller" is handwritten into the waistband of the trousers, and the Jacket has two labels from Angels costumiers, and "42 L" handwritten inside the collar. The shoes also have Angels labels. Turing's costume consists of a checkered shirt, a waistcoat, a jacket, trousers and a pair of shoes. The jacket and trousers are brown tweed, and a handwritten label in the waistcoat reads "Paul V. Verkerk". The shirt has an Angels label, and the shoes are labelled "Robert" inside. Turing's suit jacket features tears in some places, but overall, both costumes remain in very good condition.

**Estimate: £1,000 - 2,000**



**1273**  
 The Hulk's (Lou Ferrigno) Nose Appliance, Hair, and  
 Green Mask Grease  $\Omega$   
**The Incredible Hulk (T.V. Series, 1977-1982)**

The Hulk's (Lou Ferrigno) nose appliance, hair, and green mask grease from the television series The Incredible Hulk. After an overdose of gamma radiation altered his body chemistry, scientist David Banner (Bill Bixby) transformed into the all-green Incredible Hulk whenever he became angry. Designed by makeup designer Werner Keppler, this lot consists of a foam nose appliance, a mass of grey-green hair in a plastic case reading "Created for Universal City Studios Make-Up Dept. Cinematique Trimmed and Feathered Custom Styled Real Hair," and a white tin of green mask grease. The nose appliance exhibits some wear along the edges and the mask grease exhibits some liquid separation with brown oil visible in it. Dimensions: (largest) 12.75 cm x 12.75 cm x 5.25 cm (5" x 5" x 2")

**Estimate: £2,500 - 5,000**



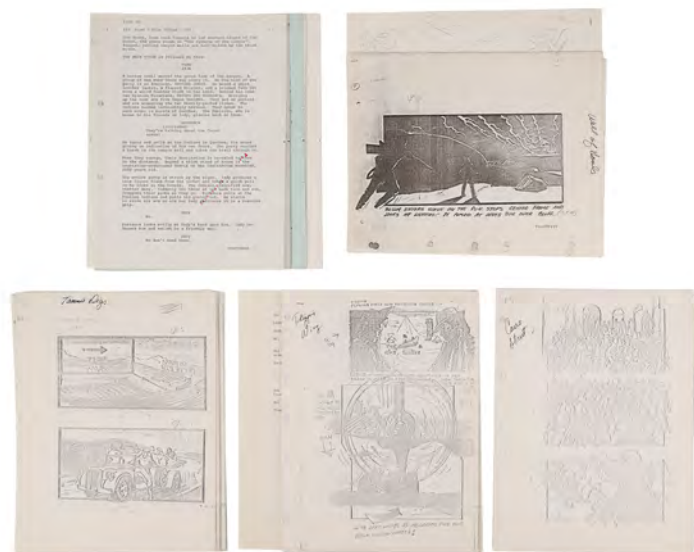

**1274**  
**Script Pages and Five Sets of Storyboards M**  
**Indiana Jones And The Raiders Of The Lost Ark (1981)**

Script pages and five sets of storyboards from Steven Spielberg's action-adventure film Indiana Jones and the Raiders of the Lost Ark. Included are 10 script pages, and 101 pages of storyboards, the storyboards are printed and annotated, though some of the annotations have been made illegible by the print quality. The shots represented by the storyboards differ slightly from those in the final cut. Dimensions: 45 cm x 30 cm x 1 cm (17.75" x 12" x 0.5")

**Estimate: £1,000 - 2,000**

**1275**  
**Hand-drawn Ark Angel of Death Concept Artwork M**  
**Indiana Jones And The Raiders Of The Lost Ark (1981)**

Hand-drawn Ark Angel of Death concept artwork from the production of Steven Spielberg's adventure film Raiders of the Lost Ark. German soldiers opened the Ark of the Covenant during the film's climax, releasing ghostly angels. The lot comprises three pieces of paper with drawings of various designs for the Angel of Death as a beautiful woman and one larger piece of paper depicting the angel as a terrifying skeletal figure. These pictures are hand-drawn in coloured pencil. Dimensions (largest piece): 62.5 cm x 44 cm (24.5" x 17.25") Sold without copyright; see copyright notice in the Buyer's Guide.

**Estimate: £1,000 - 2,000**

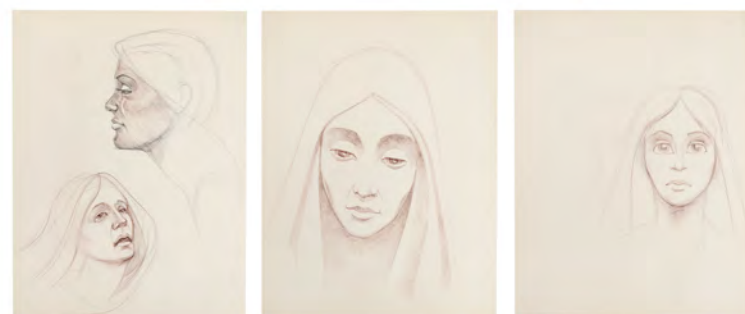

**1276**  
**German Armed Forces Eagle Standard Ω**  
**Indiana Jones And The Raiders Of The Lost Ark (1981)**

A production-made German Armed Forces eagle flagpole finial from Steven Spielberg's Raiders of the Lost Ark. German forces excavated the desert around Tanis Egypt for the lost Ark of the Covenant. Finials like this were created for the film at Elstree Studios in the U.K., which was the base for most of the live-action shoot. At the end of the shoot, additional pick-ups of the Ark opening sequence were shot at Industrial Light & Magic (ILM) in California. This flagpole finial casting was sent over for the ILM reshoots and is a raw casting out of the original mould. It retains lettering on horizontal posts at the bottom that were removed from the finished props that had been filmed during the shoot in the U.K. and Tunisia. This lot contains one flagpole finial of the German Armed Forces eagle made of resin painted in a metallic grey. Protruding sections on either side of a swastika at the base read "Deutschland Uber Alles", which when translated means "Germany above all", though these sections do not appear on the standards in the film. A small patch at the bottom from adhering to the standard pole remains, as does a small drill hole on the back centre of the eagle from securing to the pole. This lot exhibits adhesive residue on the back, chipped paint, and discolouration, as well as pitting in the foam. Dimensions: 76.25 cm x 30.5 cm x 2.5 cm (30" x 12" x 1")

**Estimate: £2,500 - 5,000**



**1277**  
**Palace Guard Robe †**  
**Indiana Jones And The Temple Of Doom (1984)**

A palace guard robe from Steven Spielberg's action-adventure sequel Indiana Jones and the Temple of Doom. Two guards wearing orange robes escorted the Little Maharaja (Raj Singh) into the dining hall of the palace, where Indiana Jones (Harrison Ford) and his other guests awaited him. This orange robe features intricate Indian-styled trim and has a costume label that reads "Palace Guard - 241 - Raiders II".

**Estimate: £1,000 - 2,000**



**1278**  
**Pankot Palace Banquet Beetle ΩΔ**  
**Indiana Jones And The Temple Of Doom (1984)**

A Pankot Palace banquet beetle from Steven Spielberg's Indiana Jones and the Temple of Doom. Willie Scott (Kate Capshaw) and her fellow dinner guests were served bugs during a banquet at Pankot Palace while Indiana Jones (Harrison Ford) attempted to solve a mystery surrounding the missing village children. This two-piece latex stag beetle with a dense, detailed shell, vinyl legs, and extended front pincers is painted with a glossy black finish. Its underside is painted brown and affixed to the top portion via a fastening strip. The beetle exhibits a missing leg, stiffness, and flaking from production use and age. Dimensions: 15.25 cm x 7.75 cm x 3.25 cm (6" x 3" x 1.25")

**Estimate: £2,000 - 4,000**

**1279**  
**Collection of Steven Spielberg-Autographed Photo, and Harrison Ford, Allison Doody and Michael Byrne Costume Photos M**  
**Indiana Jones And The Last Crusade (1989)**

A collection of Steven Spielberg-autographed photo accompanied by Harrison Ford, Allison Doody and Michael Byrne costume photos from the production of the iconic action-adventure film Indiana Jones and the Last Crusade. The black-and-white still of director Spielberg leaning on his on-set quad bike has been autographed in black ink. A collage of three stills depicting Ford in three separate Nazi disguise costumes is attached to a handwritten label. Also included are 12 polaroids of Doody and Byrne in various character costumes. Dimensions (autographed photograph): 25.5 cm x 20.5 cm x 1 cm (10" x 8" x 0.5") The autographs in this lot have been professionally authenticated by expert Garry King; see notice in the Buyer's Guide.

**Estimate: £1,000 - 2,000**

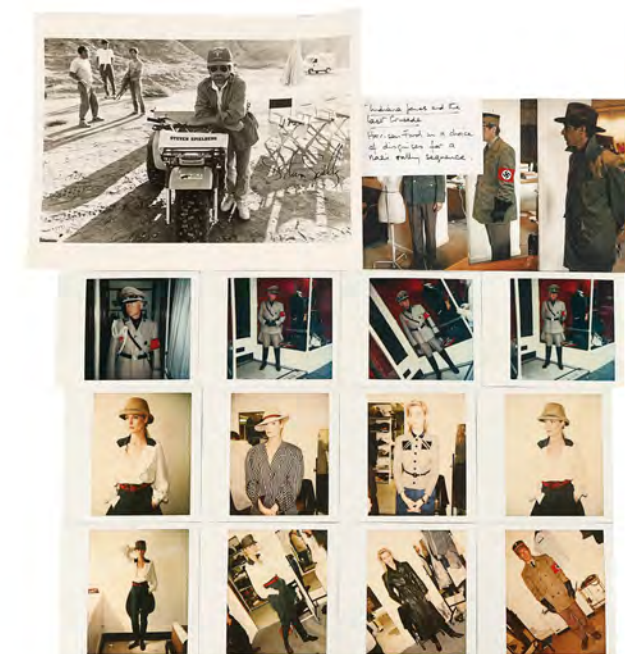

**1280**  
Set of Three Hand-annotated Tank Schematics and Photographs †Δ  
**Indiana Jones And The Last Crusade (1989)**

A set of three hand-annotated tank schematics and photographs from the production of Steven Spielberg's action-adventure sequel Indiana Jones and the Last Crusade. These three schematics of the Mark VII tank, which appeared in the film, are printed and adorned with handwritten notes and annotations in ink and pencil. Three photographs depicting the production's finished model of the tank accompany the schematics. Dimensions (one schematic): 41.75 cm x 29.75 cm (16.5" x 11.75")

**Estimate: £300 - 600**

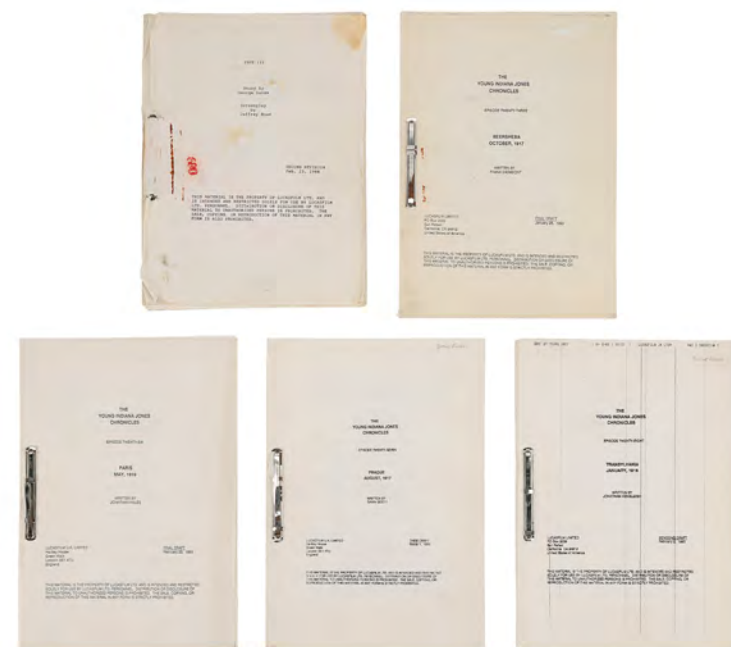

**1281**  
Annotated Production Script and Collection of Young Indiana Jones Episode Scripts †M  
**Indiana Jones And The Last Crusade (1989)**

A production script from Steven Spielberg's action-adventure sequel Indiana Jones and the Last Crusade, accompanied by a collection of Young Indiana Jones episode scripts. The Last Crusade script features hand-written annotations in ink. All of the scripts exhibit wear in the form of stains and tears. The cover and back pages of The Last Crusade script have detached from their metal fastener. Dimensions: 28.25 cm x 21.75 cm x 2 cm (11.25" x 8.5" x 0.75")

**Estimate: £1,000 - 2,000**



**1282**  
Collection of Storyboards †M  
**Indiana Jones And The Last Crusade (1989)**

A collection of storyboards from Steven Spielberg's action adventure sequel Indiana Jones and the Last Crusade. These four sets of printed storyboard pages, each bound together by metal fasteners, cover much of the third instalment in this iconic franchise. "Mike Roberts" is handwritten in ink on the front of two of the sets. Roberts was one of the production's camera operators. The storyboards exhibit wear in the form of rust to the metal fasteners and tears in the pages. Dimensions (one set): 28.25 cm x 21.75 cm x 2 cm (11.25" x 8.5" x 0.75")

**Estimate: £2,000 - 4,000**



**1283**  
Anthony Powell Hand-drawn and Coloured Elsa, Brody and Donovan Costume Design Artwork †Δ  
**Indiana Jones And The Last Crusade (1989)**

Costume design artwork by three-time Academy Award-winning costume designer Anthony Powell from the production of Steven Spielberg's adventure sequel Indiana Jones and the Last Crusade. This lot features three pages with hand-drawn and coloured artwork designed by Powell. One page is Elsa (Alison Doody), one is Brody (Denholm Elliot), and one is Donovan (Julian Glover). Each has been hand-drawn and coloured with watercolour, and each has handwritten notes and annotations. Two of the pages are signed "AP" and the Donovan page has two pieces of example fabric stapled to it. Dimensions: 21 cm x 29.5 cm (11.5" x 8.25") Sold without copyright; see copyright notice in the Buyer's Guide.

**Estimate: £1,500 - 3,000**

**1284**  
Anthony Powell Hand-coloured Indiana Jones and Main Characters Costume Design Artwork †Δ  
**Indiana Jones And The Last Crusade (1989)**

Costume design artwork by three-time Academy Award-winning costume designer Anthony Powell from the production of Steven Spielberg's adventure sequel Indiana Jones and the Last Crusade. This lot features a page of hand-coloured artwork designed by Anthony Powell for the main characters: Indy (Harrison Ford), Sallah (John Rhys-Davies), Henry (Sean Connery), Elsa (Alison Doody), Donovan (Julian Glover), Vogel (Michael Byrne), Broady (Denholm Elliot) and Kazim (Kevork Malikyan). Donovan and Kazim have different character names at this early production stage. Four of the character designs originated on a different sheet of paper and have been adhered to this sheet in strips. While the majority of the designs are printed outlines and hand-coloured (a common practice during the process to save time before the designs were finalised), there is a hand-drawn sketch of a torso at the bottom of the page. The page also features copies of handwritten notes and annotations from Powell. Dimensions: 21 cm x 29.5 cm (11.5" x 8.25") Sold without copyright; see copyright notice in the Buyer's Guide.

**Estimate: £2,000 - 4,000**



**1285**  
Anthony Powell Hand-drawn and Coloured Indiana Jones Costume Design Artwork †Δ  
**Indiana Jones And The Last Crusade (1989)**

Costume design artwork by three-time Academy Award-winning costume designer Anthony Powell from the production of Steven Spielberg's adventure sequel Indiana Jones and the Last Crusade. This lot features a page with a hand-drawn and coloured artwork designed by Powell. It is of the suit Indiana Jones' (Harrison Ford) wears when he first meets Walter Donovan (Julian Glover). The artwork is drawn in pencil and finished with watercolour paint. It is annotated by Powell in pencil along the side of the sketch. Dimensions: 21 cm x 29.5 cm (11.5" x 8.25") Sold without copyright; see copyright notice in the Buyer's Guide.

**Estimate: £2,000 - 4,000**



**1286**  
 Anthony Powell Hand-coloured Soldier  
 Costume Design Artwork †  
**Indiana Jones And The Last Crusade (1989)**

Costume design artwork by three-time Academy Award-winning costume designer Anthony Powell from the production of Steven Spielberg's adventure sequel Indiana Jones and the Last Crusade. This lot features two pages with hand-coloured artwork designed by Powell. One page has the Grail Knight (Robert Eddison) painted in watercolour and is signed "AP". The other page features hand-coloured costume designs for camel riders, soldiers and the Knight. These design are accompanied by handwritten notes and annotations. Dimensions: 21 cm x 29.5 cm (11.5" x 8.25") Sold without copyright; see copyright notice in the Buyer's Guide.

**Estimate: £1,500 - 3,000**



**1287**  
 Pair of Crew T-shirts and Pair of Crew Hats m  
**Indiana Jones Series (1981-2023)**

A pair of crew T-shirts and a pair of crew hats from the production of the iconic action-adventure franchise Indiana Jones. The Temple of Doom crew T-shirt is a size "L" while the Last Crusade crew T-shirt is a size "XL". One crew cap is a Stunts Incorporated cap from The Last Crusade and the other is from The Temple of Doom.

**Estimate: £500 - 1,000**



**1288**  
 Harrison Ford-autographed Official Fan Hat m  
**Indiana Jones Series (1981-2023)**

An autographed official fan hat from the Indiana Jones film series. The brim of the hat has been autographed in silver ink by Harrison Ford, who portrayed the titular Indiana Jones, and is a replica of the hat worn by Jones in the films. It is made of brown wool, in a size "Medium". It is satin lined, with gold printing on the lining, and features an Indiana Jones logo printed on the inner headband. A sticker inside the hat reads "15264-2". The autographs in this lot have been professionally authenticated by expert Garry King; see notice in the Buyer's Guide

**Estimate: £1,000 - 2,000**

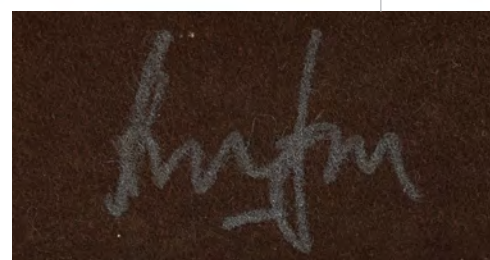

**1289**  
 Margaret Thatcher's (Meryl Streep) Screen-matched  
 Prime Minister Costume, Education Secretary  
 Costume and Cabinet Meeting Costume †  
**The Iron Lady (2011)**

Three Margaret Thatcher (Meryl Streep) costumes from Phyllida Lloyd's biographical drama The Iron Lady. Thatcher wore one of her skirt suits as Education Secretary while sitting in the House of Commons; another during a cabinet meeting and later during the review of a TV interview; and the third as Prime Minister while in the House of Commons. The pattern of the Prime Minister costume matches it to the one seen on screen. All three costumes feature matching jackets and skirts. The Education Secretary costume is accompanied by a blue hat, and the other two costumes each include a blouse. All costume items have a handwritten "Meryl Streep" label.

**Estimate: £2,000 - 4,000**



**1291**  
 Dennis Cooper's (Michael Palin) Screen-matched Red  
 Herring Shield m  
**Jabberwocky (1977)**

Dennis Cooper's (Michael Palin) red herring shield from Terry Gilliam's fantasy film Jabberwocky. Dennis used the shield on his quest to defeat the terrible Jabberwocky monster, which threatened his local village. The markings, paintwork, and scratches on this prop screen-match exactly to the sequences prior to Dennis' fight with the creature. This shield, decorated with a red herring, check pattern and multiple fleur-de-lis, is made from foam, wood, and aluminium. It features two leather straps on the back, and exhibits considerable wear from production use and age. Dimensions: 58 cm x 81 cm x 5 cm (23" x 32" x 2")

**Estimate: £2,000 - 4,000**

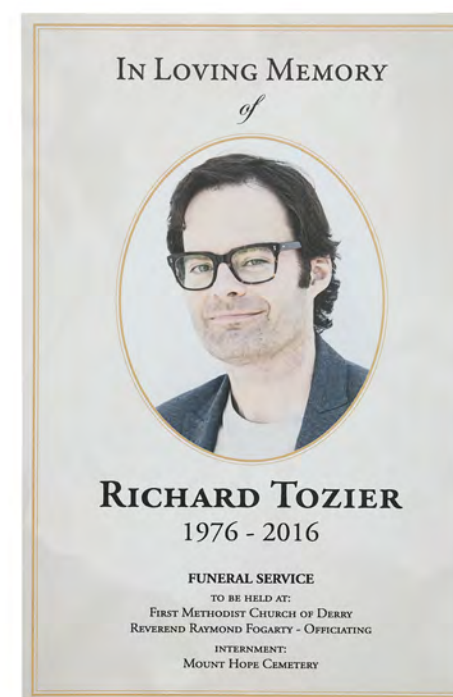

**1290**  
 Richard Tozier (Bill Hader) Funeral Service Card †  
**It Chapter Two (2019)**

A Richard Tozier (Bill Hader) funeral service card from Andy Muschietti's horror sequel It Chapter Two. Richie is taunted by Pennywise and given a card for his own funeral service. The front features a picture of Richie and details of the service, and the back features a disparaging summation of Richie's life, written by Pennywise. Dimensions: 21.5 cm x 14 cm (8.5" x 5.5")

**Estimate: £300 - 600**



**1292**  
 Sir James Bond's (David Niven) Jacket +  
**James Bond: Casino Royale (1967)**

Sir James Bond's (David Niven) jacket from John Huston, Kern Hughes, Robert Parrish, Joe McGrath and Val Guest's Casino Royale. Bond wore his jacket when he visited his daughter Mata Bond (Joanna Pettet) and convinced her to go to East Berlin on a mission for MI6. The single-breasted jacket was created by tailor Benson, Perry & Whitley. Made in a silk-like woven fabric with silk trim, the jacket features a breast pocket, two waist pockets and four buttons running down the front. Two internal pockets are present, one of which has a label attached. Originally white, the jacket is now yellow, having been dyed for use in subsequent productions. The jacket was tailored for Niven, is labelled "David Niven" and "11/7/66", and is unsized. The jacket is well-used with tears around the underarms and one of the buttons coming away.

**Estimate: £1,000 - 2,000**



**1293**  
 Large Collection of Crew Items m  
**James Bond Franchise (1953-Present)**

An extensive collection of crew clothing and accessories from various James Bond productions. The lot includes six caps, four jackets, two fleeces, eleven T-shirts, six polo shirts, three shirts, two jumpers, a cleaning cloth and a scarf. Some of the clothing still has its original tags and features an array of designs. The sizes range from a size L to a XXX-Large. The two grey A View To a Kill "Icelandic Unit 1984" T-shirts are smaller but not labelled. A comprehensive list of the clothing included in the lot can be found in the online description. The lot exhibits general wear, some minor bobbling, marks and staining.

**Estimate: £1,500 - 3,000**



**1294**  
 British Half Sheet Poster m  
**James Bond: From Russia With Love (1963)**

A British Half Sheet poster from the promotion of Terence Young's Bond film From Russia with Love. Designed by Eric Pulford and Renato Fratini, this rare poster differs from the more common posters seen for the film, with Bond presented in greyscale and the other characters coloured yellow. This was the only British Bond poster campaign that Fratini worked on. This poster has been rolled and then flattened, creating a wavy effect. Dimensions: 56 cm x 70.5 cm (22" x 27.75")

**Estimate: £3,000 - 6,000**

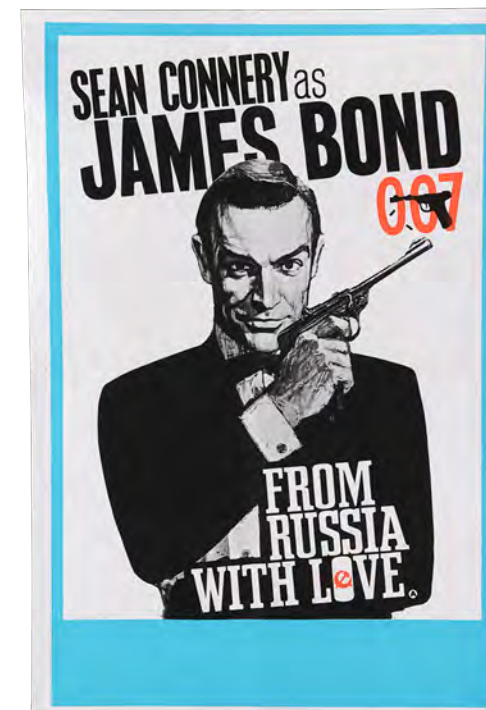

**1295**  
 British Double Crown Poster – Sean Connery Style m  
**James Bond: From Russia With Love (1963)**

A British Double Crown poster from the promotion of Terence Young's Bond film From Russia with Love. Designed by Eric Pulford and Joseph Caroff, this Double Crown features day-glo highlights in both the "007" at the top and the hammer and sickle at the bottom. The poster has been folded into quarters and features general creasing and edge wear. Dimensions: 76 cm x 51.5 cm (30" x 20.25")

**Estimate: £3,000 - 6,000**

**1296**  
 David Frangioni Collection: US 24-Sheet, 1965 n  
**James Bond: Goldfinger (1964)**

A US 24-Sheet poster from the promotion of Guy Hamilton's Bond film Goldfinger. The design of this huge and incredibly rare 24-sheet poster is perfectly suited to the format. A massive image of the famous gold-painted character Dink (Margaret Nolan) is stretched over roughly 20 feet. Nolan completely dominates the design, with the face of Sean Connery tactfully placed to appease the censors. There are some minor areas of paper loss and a few larger tears on some panels. One panel has red ink on the reverse which has bled through to the white lettering of "Goldfinger". However, the poster is in very good overall condition. Dimensions: 275 cm x 610 cm (108.25" x 240.25")

**Estimate: £2,000 - 4,000**



**1297**  
 Juan Sanchez-Villalobos Ramirez's (Sean Connery) Reference Katana and Scabbard n  
**James Bond: You Only Live Twice (1967)/ Highlander (1986)**

A reference katana and scabbard from Lewis Gilbert's You Only Live Twice and Russell Mulcahy's Highlander. This katana originally came from the personal collection of renowned SFX technician Bert Luxford, who purchased it for use on You Only Live Twice. It was ultimately unseen in that film, but later "reunited" with its star, Sean Connery, for the production of Highlander. Ultimately, it was used as a reference for Juan Sanchez-Villalobos Ramirez's main weapon as it was decided his sword and costume needed to be more flamboyant. This lot consists of a metal sword with an ornate faux-ivory grip and a leather-wrapped wooden scabbard. It exhibits some wear from age and use, most notably areas of scuffing on the scabbard, and the handle has come loose from the blade. Dimensions: (sheathed) 104 cm x 8.5 cm x 8.5 cm (41" x 3.25" x 3.25")

**Estimate: £3,000 - 6,000**

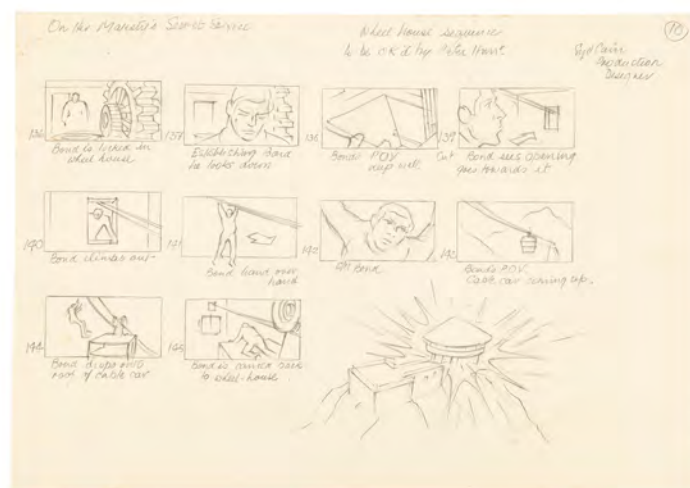

**1298**  
 Syd Cain Hand-drawn Storyboard Page  $\Omega$   
**James Bond: On Her Majesty's Secret Service (1969)**

An early Syd Cain hand-drawn draft storyboard page from the production of Peter R. Hunt's Bond film On Her Majesty's Secret Service. Eminent art director and production designer Cain worked on many Bond films, including Dr. No and On Her Majesty's Secret Service. He also worked with prestigious director Alfred Hitchcock as production designer on Frenzy. Cain created these drafts - which he called "roughs" - to show to the director for comments before refining the final storyboard. This storyboard page features 10 hand-drawn pencil illustrations of the "Wheel House Sequence". The page is signed by Cain in the top right corner. Dimensions: 42 cm x 29.5 cm (16.5" x 11.5") Sold without copyright; see copyright notice in the Buyer's Guide.

**Estimate: £1,500 - 3,000**

**1299**  
 Syd Cain Hand-drawn Storyboard Page  $\Omega$   
**James Bond: On Her Majesty's Secret Service (1969)**

An early Syd Cain hand-drawn draft storyboard page from the production of Peter R. Hunt's Bond film On Her Majesty's Secret Service. Eminent art director and production designer Cain worked on many Bond films, including Dr. No and Live and Let Die. He also worked with Alfred Hitchcock as production designer on Frenzy. Cain created these drafts - which he called "roughs" - to show the director for comments and Cain would then refine them to create the final storyboard. This storyboard page features 12 hand-drawn pencil illustrations of the scene in which Tracy (Diana Rigg) and James Bond (George Lazenby) elude their enemies by driving amongst a ice rink car race. Dimensions: 42 cm x 29.5 cm (16.5" x 11.5") Sold without copyright; see copyright notice in the Buyer's Guide.

**Estimate: £1,500 - 3,000**

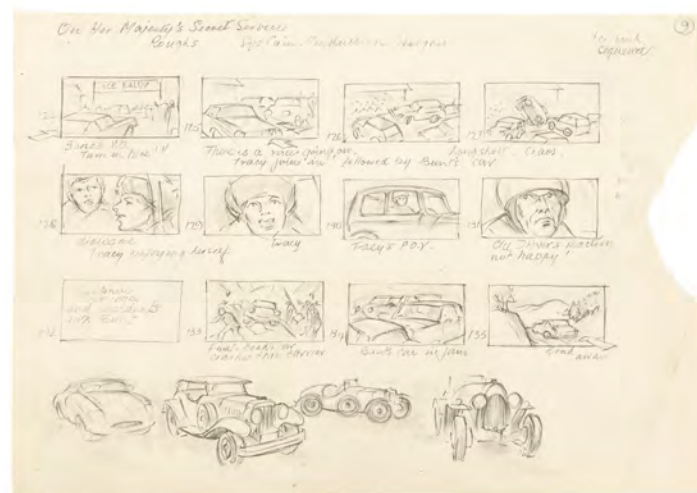

**1300**  
 Syd Cain Hand-drawn Storyboard Page  $\Omega$   
**James Bond: On Her Majesty's Secret Service (1969)**

An early Syd Cain hand-drawn draft storyboard page from the production of Peter R. Hunt's Bond film On Her Majesty's Secret Service. Eminent art director and production designer Cain worked on many Bond films, including Dr. No and On Her Majesty's Secret Service. He also worked with prestigious director Alfred Hitchcock as production designer on Frenzy. Cain created these drafts - which he called "roughs" - to show to the director for comments before refining the final storyboard. This storyboard page features 13 hand-drawn pencil illustrations depicting part of the sequence in which James Bond (George Lazenby) pursued Blofeld (Telly Savalas) down a mountain in a toboggan chase. The page is signed by Cain in the top right corner. Dimensions: 42 cm x 29.5 cm (16.5" x 11.5") Sold without copyright; see copyright notice in the Buyer's Guide.

**Estimate: £1,500 - 3,000**



**1301**  
 Syd Cain Hand-drawn Storyboard Page  $\Omega$   
**James Bond: On Her Majesty's Secret Service (1969)**

An early Syd Cain hand-drawn draft storyboard page from the production of Peter R. Hunt's Bond film On Her Majesty's Secret Service. Eminent art director and production designer Cain worked on many Bond films, including Dr. No and On Her Majesty's Secret Service. He also worked with prestigious director Alfred Hitchcock as production designer on Frenzy. Cain created these drafts - which he called "roughs" - to show to the director for comments before refining the final storyboard. This page features 15 hand-drawn pencil illustrations depicting part of the sequence in which James Bond (George Lazenby) and his allies infiltrated Blofeld's (Telly Savalas) research facility at the top of Piz Gloria mountain in search of the sinister villain himself. The page is hand-signed by Cain in the top right corner. Dimensions: 42 cm x 29.5 cm (16.5" x 11.5") Sold without copyright; see copyright notice in the Buyer's Guide.

**Estimate: £1,500 - 3,000**



**1302**  
 George Lazenby Autographed US Six Sheet  $\Omega$   
**James Bond: On Her Majesty's Secret Service (1969)**

A US Six Sheet for Peter R. Hunt's Bond film On Her Majesty's Secret Service. This US release poster depicts Lazenby, in his single Bond film appearance, casually skiing away from his pursuers beside Bond girl Tracy (Diana Rigg). Lazenby has handwritten his signature as well as "007" in black marker pen on the red square section and the poster is conservation linen-backed. Dimensions: 208.25 cm x 208.25 cm (82" x 82") Artists: Robert McGinnis & Frank McCarthy. The autographs in this lot have been professionally authenticated by expert Garry King; see notice in the Buyer's Guide.

**Estimate: £3,000 - 6,000**



**1303**  
 Hand-sketched Costume Artwork of Solitaire (Jane Seymour)  $\Omega$   
**James Bond: Live And Let Die (1973)**

A costume design artwork for Solitaire (Jane Seymour) from the production of Guy Hamilton's Bond film Live and Let Die. Solitaire was a voodoo psychic medium working under the command of Bond villain Kananga (Yaphet Kotto), also known as Mr. Big. This original production artwork that depicts Solitaire in one of her many elaborate and elegant dresses is hand-sketched in pencil and then embellished with hand-painted colouring. The style of the dress presented in this piece indicates it was created to speculate on the creative design and aesthetic of Solitaire's red and gold gown that she wore in prominent scenes. Notes adorn the space around the sketch, including a personal message signed by the film's costume designer, Julie Harris. Dimensions: 50 cm x 40 cm (19.75" x 15.75") Sold without copyright; see copyright notice in the Buyer's Guide.

**Estimate: £2,000 - 4,000**

**1304**  
 Syd Cain Hand-drawn Crocodile Farm  
 Storyboard Page [Ω](#)  
**James Bond: Live And Let Die (1973)**

A Syd Cain hand-drawn crocodile farm storyboard page from the production of Guy Hamilton's Bond movie Live and Let Die. Eminent art director and production designer Cain worked on many Bond films, including Dr. No and On Her Majesty's Secret Service, and he is credited as a storyboard artist on GoldenEye. Cain also worked with Alfred Hitchcock as the production designer on Frenzy. Cain created these drafts - which he called "roughs" - to show the director for comments and Cain would then refine them to create the final storyboard. This storyboard partly depicts, across nine frames, the scene on the crocodile farm where James Bond (Roger Moore) is left by Tee Hee (Julius Harristo) to be eaten alive. The sketches and annotations are hand-drawn in pencil with the film's title headlined. Dimensions: 42 cm x 29.5 cm (16.5" x 11.5") Sold without copyright; see notice in the Buyer's Guide.



**Estimate: £1,500 - 3,000**



**1305**  
 Syd Cain Hand-drawn Storyboard Page [Ω](#)  
**James Bond: Live And Let Die (1973)**

An early hand-drawn Syd Cain draft storyboard page from the production of Guy Hamilton's Bond film Live and Let Die. Eminent art director and production designer Cain worked on many Bond films, including Dr. No and On Her Majesty's Secret Service. He also worked with prestigious director Alfred Hitchcock as production designer on Frenzy. Cain created these drafts - which he called "roughs" - to show to the director for comments before refining the final storyboard. This page features nine hand-drawn pencil storyboards depicting the scene where James Bond (Roger Moore) used his magnetic watch gadget to attract a nearby rowing boat as he endeavoured to escape the crocodiles that surrounded him. The page is hand-signed by Cain in the bottom right corner. Dimensions: 42 cm x 29.5 cm (16.5" x 11.5") Sold without copyright; see copyright notice in the Buyer's Guide.

**Estimate: £1,500 - 3,000**

**1306**  
 Factory Entertainment Golden Gun Replica [M](#)  
**James Bond: The Man With The Golden Gun (1974)**

A Factory Entertainment replica of Sacaramanga's (Christopher Lee) signature weapon from Guy Hamilton's Bond film The Man with the Golden Gun. This 1:1 scale gold-plated replica, limited to 1000 worldwide, can be assembled from separate components like the original prop. It features an unscrewable fountain pen barrel, a cigarette lighter main body, a cigarette case grip, and a flexible cuff-link trigger. It also comes with one engraved "007" golden bullet. The lot also includes a plastic stand and a wooden display base, which features a plaque numbered "279", an acrylic display case, a certificate of authenticity, an information booklet and its original packaging. The gun exhibits minor marks and scratches, and there are signs of creasing on the packaging. Dimensions (gun): 24 cm x 2 cm x 13.5 cm (9.5" x 0.75" x 5.25")

**Estimate: £600 - 1,200**

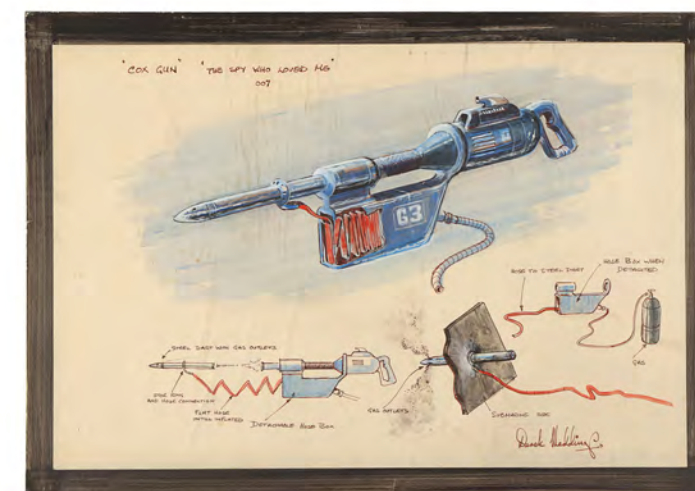

**1307**  
 Derek Meddings Hand-illustrated Cox Gun Concept Art [M](#)  
**James Bond: The Spy Who Loved Me (1977)**

A piece of Derek Meddings' hand-illustrated cox gun concept artwork from the production of Lewis Gilbert's Bond film The Spy Who Loved Me. Stromberg's (Curd Jurgens) men fired steel darts from cox guns into the submarine James Bond (Roger Moore) and his allies were travelling on. The artwork is hand-painted with watercolours, depicting the prop and examples of its use. It has been hand-signed in ink by Meddings in the bottom right corner. The artwork is rendered on paper but is adhered to a piece of black card. Dimensions: 42 cm x 30.5 cm (16.5" x 12") Sold without copyright; see copyright notice in the Buyer's Guide.

**Estimate: £1,000 - 2,000**

**1308**  
 Pair of Film Cans [M](#)  
**James Bond: The Spy Who Loved Me (1977)**

Pair of film cans containing 35mm rolls from the production of Lewis Gilbert's Bond film The Spy Who Loved Me. The cans contain frames of Roger Moore, who played Bond, performing the iconic gunshot logo action. Both cans exhibit rusting from age. Dimensions (largest can): 26.75 cm x 26.75 cm x 4.75 cm (10.5" x 10.5" x 2")

**Estimate: £1,000 - 2,000**



**1309**  
 Miniature Space Laser Gun [M](#)  
**James Bond: Moonraker (1979)**

A miniature astronaut laser rifle from Lewis Gilbert's Bond film Moonraker. Miniature versions of laser rifle-wielding US Marines were used for certain shots during the climactic battle against Drax's (Michael Lonsdale) space-station guards. Fabricated by a member of the production's visual effects team, headed by renowned visual effects supervisor Derek Meddings, this resin miniature rifle was based on an IMI Uzi submachine gun, like the life-sized rifles used in other shots. Dimensions: 16.5 cm x 3 cm x 8.75 cm (6.5" x 1.25" x 3.5")

**Estimate: £2,000 - 4,000**



**1310**  
Drax Technician Jumpsuit m  
**James Bond: Moonraker (1979)**

A Drax technician's jumpsuit from Lewis Gilbert's Moonraker. Hugo Drax's (Michael Lonsdale) henchmen wore operator jumpsuits throughout the film as they prepared to launch the Moonraker jet that would destroy Earth and humanity with nerve gas. This yellow polyester zip-front jumpsuit labelled "Alexandra Middendorf" on the interior features white rubber pipe trim along the pockets, zipper sleeves, and metal snap-button closures on its cinching belt and ankles. The jumpsuit exhibits minor discolouration and cracking material on the collar.

**Estimate: £1,200 - 2,400**



**1311**  
Drax Henchman Cap m  
**James Bond: Moonraker (1979)**

A Drax henchman cap from Lewis Gilbert's Bond movie Moonraker. Technicians wore caps with matching jumpsuits while working for Hugo Drax (Michael Lonsdale) at his space station. James Bond (Roger Moore) and Holly Goodhead (Lois Chiles) stole and disguised themselves in technician outfits to sneak aboard the station. The mustard cap has a cotton body and plastic visor, while it no longer features the "Drax Industries" logo.

**Estimate: £750 - 1,500**



**1312**  
Keith Hamshere Collection: Collection of Silver Gelatin Production Photographs m  
**James Bond: For Your Eyes Only (1981)**

A collection of silver gelatin photographs from the production of John Glen's Bond film For Your Eyes Only. This lot comes from the personal collection of renowned stills photographer Keith Hamshere. This lot comprises 111 photographs from the production, 106 of which are black-and-white silver gelatin prints and five are colour prints. They feature stars Roger Moore (James Bond), Carole Bouquet (Melina Havelock), Chaim Topol (Milos Columbo), Lynn-Holly Johnson (Bibi Dahl) and Julian Glover (Aristotle Kristatos). Most have a handwritten number on the back alongside Hamshere's stamp. A few of the photographs have a sticky residue on the front. Dimensions (each): 24.5 cm x 16.5 cm (9.75" x 6.5") Sold without copyright; see copyright notice in the Buyer's Guide.

**Estimate: £2,000 - 4,000**

**1313**  
Set of Three Hand-drawn Comic Pages by Howard Chaykin m  
**James Bond: For Your Eyes Only (1981)**

A set of three hand-drawn comic pages by Howard Chaykin for the comic book adaptation of John Glen's Bond film For Your Eyes Only. Marvel Comics produced the adaptation, which was written by Larry Hama, pencilled by Chaykin, inked by Vincent Colletta and edited by Dennis O'Neil. The work was initially published as issue 19 of Marvel Comics Super Special and was later released as a two-issue adaptation in October and November 1981. The pages are rendered in black ink and there are also areas of corrective fluid and pencil marks. The pages have some staining, remnants of sticky tape and ink blotting on the reverse. Dimensions (each): 40 cm x 27 cm (15.75" x 10.5") Sold without copyright; see copyright notice in the Buyer's Guide.

**Estimate: £1,000 - 2,000**



**1314**  
Jungle Spider m  
**James Bond: Octopussy (1983)**

A jungle spider from John Glen's Bond film Octopussy. James Bond (Roger Moore) fled through the jungle as he was hunted by Kamal Khan (Louis Jourdan) and his men. During the chase, Bond ran into a giant web populated with large jungle spiders, one of which clung to his forearm. The spider is made of rubber, painted accordingly and embellished with faux hair. Its lightweight design would have enabled it to remain attached to the spider web in the film. Dimensions: 12 cm x 8.25 cm x 2.75 cm (4.75" x 3.25" x 1")

**Estimate: £500 - 1,000**

**1315**  
Production Script and Paperwork m  
**James Bond: Never Say Never Again (1983)**

A production script and paperwork from the production of Irvin Kershner's spy film James Bond: Never Say Never Again. Included in this lot are a script, unit lists, transport lists, set lists, letters and meeting notes. The script has no title page and is not attributed to anyone, and has been annotated throughout. The set lists have the costs of the sets and models handwritten onto them, and the meeting notes are annotated by hand. The script and some of the paperwork is stained. Dimensions: 34 cm x 25 cm x 4 cm (13.5" x 10" x 1.75")

**Estimate: £700 - 1,400**



**1316**  
Sean Connery-autographed Call Sheet m  
**James Bond: Never Say Never Again (1983)**

A call sheet autographed by Sean Connery from the production of Irvin Kershner's Bond film Never Say Never Again. The film was Connery's return to the role of James Bond, and this call sheet has been autographed in blue ink by Connery. It is dated "10th December, 1982" and lists which members of the cast, props and equipment were needed for the shoot that day. Dimensions: 29.5 cm x 21 cm (11.5" x 8.25") The autograph in this lot has been professionally authenticated by expert Garry King; see notice in the Buyer's Guide.

**Estimate: £400 - 800**

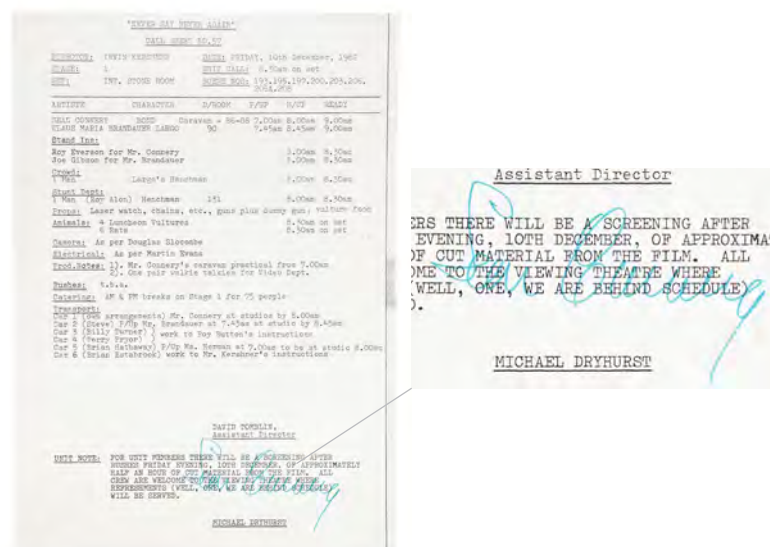

**1317**  
Keith Hamshere Collection: Collection of Production and Promotion Photographs m  
**James Bond: A View To A Kill (1985)**

A collection of photographs from the production and promotion of John Glen's Bond film A View to a Kill. This lot comes from the personal collection of renowned stills photographer Keith Hamshere. The lot comprises 23 photographs printed onto Kodak photography paper. They are a mix of on-set photography and posed promotional photos featuring stars Roger Moore, Christopher Walken, Grace Jones and Tanya Roberts. Each one has a handwritten number on the reverse. Dimensions (each): 39 cm x 26 cm (15.25" x 10.25") Sold without copyright; see copyright notice in the Buyer's Guide.

**Estimate: £1,000 - 2,000**

**1318**  
Keith Hamshere Collection: Collection of Silver Gelatin Production and Promotional Photographs m  
**James Bond: A View To A Kill (1985)**

A collection of large silver gelatin production and promotional photographs from John Glen's Bond film A View to a Kill. This lot comes from the personal collection of renowned stills photographer Keith Hamshere. This lot comprises 17 black-and-white silver gelatin photographs, six of which have been signed by the photographer. They are a mixture of production and promotional images and feature stars Roger Moore (James Bond), Tanya Roberts (Stacey Sutton), Grace Jones (May Day) and Christopher Walken (Max Zorin). Each image has a number handwritten in pencil on the reverse. Dimensions (each): 51 cm x 40.5 cm (20" x 16") Sold without copyright; see copyright notice in the Buyer's Guide.

**Estimate: £2,000 - 4,000**



**1319**  
Hand-annotated Storyboards, Hand-annotated Production Ephemera and Script m  
**James Bond: A View To A Kill (1985)**

Hand-annotated storyboards, hand-annotated production ephemera and a script from the production of John Glen's Bond film A View to a Kill. The lot comprises a hand-annotated story beat list with "If we delay 2 weeks how is the weather" handwritten on its front in black ink; a collection of printed storyboards, some of which have been hand-annotated in purple and green marker pen; a collection of movement orders, one of which is hand-annotated in blue ink; an memo hand-annotated in purple ink, attached to several pages of printed storyboard image sketches; a pamphlet of printed storyboards; numerous call sheets for various filming dates; a View to a Kill script, dated "June 20, 1984"; a 12th June 1985 Royal Charity Premiere programme; six A View to a Kill decals; and a lone polaroid depicting the configuration of a set for an exterior scene. The lot exhibits resting on some of the paper clips that bind certain documents together. Dimensions (script): 30 cm x 21.75 cm x 2 cm (11.75" x 8.5" x 0.75")

**Estimate: £1,000 - 2,000**

**1320**  
Kara Milovy's (Maryam d'Abo) Stunt Ski Jacket m  
**James Bond: The Living Daylights (1987)**

Kara Milovy's (Maryam d'Abo) stunt jacket from John Glen's Bond film The Living Daylights. Milovy wore a grey ski jacket as she and James Bond (Timothy Dalton) escaped from Bratislava into Austria, eluding the KGB and Czech police by tobogganing on a cello case. FILA-branded, this jacket features detachable sleeves and a faux fur collar. The exterior and inner lining are made of cotton and polyamide, while the jacket's padding is polyester. The left arm exhibits some faint staining.

**Estimate: £1,000 - 2,000**



**1321**  
Set of Casino de Isthmus City Chips tΔ  
**James Bond: Licence To Kill (1989)**

A set of Casino de Isthmus City chips from John Glen's Bond film Licence to Kill. James Bond (Timothy Dalton) posed as a high roller while visiting the Casino de Isthmus City to catch drug baron Sanchez's (Robert Davi) attention. These colourful poker chips are made of plastic, with their value and the casino name printed on them in black and gold fonts, respectively. Dimensions (one chip): 4 cm x 4 cm (1.5" x 1.5")

**Estimate: £1,000 - 2,000**



**1322**  
Keith Hamshere Collection: Set of Nine Timothy Dalton Promotional Stills M  
**James Bond: Licence To Kill (1989)**

A set of nine promotional stills featuring Timothy Dalton from John Glen's Bond film Licence to Kill. This lot comes from the personal collection of renowned stills photographer Keith Hamshere. This lot comprises nine photographs - one of which is a duplicate - from a promotional photoshoot with Dalton in character as Bond. Five feature him armed with a pistol in a black shirt and trousers, and four feature him in an intentionally distressed suit and with a bloodied face. An image from this photoshoot appeared on several of the posters promoting the film, although that is not one of the photos included in this lot. The photos are printed on Fujichrome paper. Dimensions (each): 40.5 cm x 30.5 cm (16" x 12") Sold without copyright; see copyright notice in the Buyer's Guide.

**Estimate: £1,000 - 2,000**



**1323**  
Franz Sanchez's (Robert Davi) Suit M  
**James Bond: Licence To Kill (1989)**

Franz Sanchez's (Robert Davi) suit from John Glen's James Bond film Licence to Kill. Drug lord Sanchez wore his suit during the film's finale, when his base was consumed by fire. The label on the jacket's inner pocket reads "R. Davi Fire Suit Coat", and the label in the waistband of the trousers reads "R. Davi Fire Suit Pants". The trousers feature a solid brass buckle on which "Cub Scouts BSA" is engraved. There is some minor staining from production use on the right sleeve and lapel.

**Estimate: £500 - 1,000**

**1324**  
Set of Four Hand-drawn Daily Express Comic Strip Panels by John McLusky M  
**James Bond Franchise (1953-Present)**

A set of Four hand-drawn Daily Express comic strip panels by John McLusky. Starting in 1958, the Daily Express newspaper published daily serialised James Bond comic strips, starting with Casino Royale. These four strips are numbers 78 to 81 consecutively and feature hand-drawn artwork by McLusky, who is credited with changing Bond's appearance to be more rugged and masculine. The artwork is rendered mostly in black ink and there are also areas of corrective fluid, pencil marks, and sections adhered to the board from another page. The panels have some minor wear, including discolouration and staining. Dimensions: 14 cm x 42.5 cm (5.5" x 16.75") Sold without copyright; see copyright notice in the Buyer's Guide.

**Estimate: £2,000 - 4,000**



**1326**  
M's (Bernard Lee) Screen-matched Framed HMS Glory Picture M  
**James Bond: Various Productions**

M's (Bernard Lee) screen-matched framed HMS Glory picture from multiple James Bond films. M displayed the embroidered picture of the pre-dreadnought battleship in his office where he regularly held meetings with 007. The picture screen-matches most clearly to You Only Live Twice though notable marks around the frame and the shape of the smoke trails on the image. The picture appeared in a total of 10 Bond films: From Russia with Love, Goldfinger, Thunderball, You Only Live Twice, On Her Majesty's Secret Service, The Man with the Golden Gun, The Spy Who Loved Me, Moonraker, For Your Eyes Only, and A View to a Kill. The wood frame has some wear from use and age and the back of the frame has some string for hanging and some handwritten notes. Dimensions: 41 cm x 52.5 cm x 2 cm (16.25" x 20.75" x 0.75")

**Estimate: £2,000 - 4,000**

**1325**  
35mm Mitchell Film Camera M  
**James Bond: Various Productions**

A 35mm Mitchell high-speed film camera from the production of various films, including the first seven James Bond movies, as well as Desmond Davis' 1981 fantasy adventure Clash of the Titans. This camera, numbered "519", was originally assigned to the Pinewood Studios' special effects department and was used for any required high-speed filming. When Pinewood ceased to be a full-facility studio and closed its special effects department in the early 1970s, its head Cliff Culley started his own company using the same equipment. Culley's company closed in 1999, and the camera has remained out of use since, though it is still fully operational. Two steel cogs enable its high-speed capability, of up to 144 frames per second. The camera comes with two motors: one standard motor and one for high-speed filming. The camera is presented on an MOY head, a robust piece of engineering well suited to the rough and tumble of special effects work. Its original wooden tripod has been replaced with a more robust metal tripod. Also included are four photographs of the camera in use, on the sets of Reilly Ace of Spies, Strauss Dynasty, Nightbreed and one unidentified film. Dimensions: 170 cm x 72 cm x 77 cm (67" x 28.5" x 30.5")

**Estimate: £4,000 - 8,000**



**1327**  
Set of Three Bond Theme Film Cans M  
**James Bond: Various Productions**

Three Bond theme film cans from various instalments in the iconic spy movie franchise. These cans are part of a selection of Bond main title sequences and trailer designs. The film in the smallest can has completely rusted. All of the cans exhibit significant rusting. The Dimensions (largest can): 29 cm x 29 cm x 4.75 cm (11.5" x 11.5" x 2")

**Estimate: £1,000 - 2,000**

**1328**  
Michael G. Wilson Producer's Chair m  
**James Bond: Various Productions**

Michael G. Wilson's set chair from various James Bond productions on which he worked as a producer. Wilson attained his first credit for a Bond film in a junior position on Guy Hamilton's Goldfinger. He has gone on to work his way up the ranks, contributing to the franchise in numerous creative capacities. For instance, Wilson has been a producer on every single one of the last 15 Bond films, from Moonraker to the most recent instalment, No Time to Die. His Bond screenwriting credits include Licence to Kill, The Living Daylights, A View to Kill, and Octopussy. Wilson has also had cameo appearances in many of the Bond films he has worked on. The back of this chair, which features his name embroidered on the rear, has been nailed to the wooden frame to secure its position. "Pinewood" is stamped in black on the wooden underside of the seat. The original bottom fabric of the chair is included, however, it exhibits holes and tears, and has consequently been replaced by a new piece. Dimensions: 40 cm x 54 cm x 115 cm (15.75" x 21.25" x 45.25")



**Estimate: £1,000 - 2,000**



**1329**  
Acmade 35mm Picture Sync Film Editor m  
**James Bond: Various Productions**

An Acmade 35mm Picture Sync Film Editor used in post-production for various films within the James Bond franchise. These film's include Moonraker, Octopussy, The Living Daylights, Licence to Kill, as well as Jim Henson's Labyrinth and Andrew V. McLaglen's war drama The Sea Wolves. This metal machine and the accompanying wooden amplifier speaker still function when their leads are connected to a power source. When used together, the machine can sync the film frames with the appropriate sound from the speaker. The machine also features a frame counter, frame viewer, four audio tracks, and one film track. "John Grover Badingham Films LTD." has been handwritten in black marker pen on one end of the machine and the back of the amplifier. Also included is a wooden plaque that reads "James Bond Film Editing Machine". Dimensions (editing machine): 75 cm x 24.5 cm x 29 cm (29.5" x 9.75" x 11.5") Contains electronics; see electronics notice in the Buyer's Guide. Contains mechanical components; see mechanical notice in the Buyer's Guide. Special shipping required; see special shipping notice in the Buyer's Guide.

**Estimate: £1,000 - 2,000**

**1330**  
Russian Scientist Lab Coat with Collection of Crew  
Jackets and Tops m  
**James Bond: Various Productions**

A Russian scientist lab coat from Michael Apted's Bond film The World Is Not Enough, with a collection of crew jackets and tops from various other James Bond productions. Russian scientists wore lab coats at the ICBM base in Kazakhstan when Bond visited. The remaining items comprise a size "XX-Large" nylon GoldenEye stunt crew bomber jacket; a size "L" nylon GoldenEye film crew bomber jacket; a size "XL" polycotton Goldeneye crew jacket; a size "XL" cotton GoldenEye cast and crew polo shirt; two size "XXL" nylon Tomorrow Never Dies cast and crew jackets; one size "XL" polyester Tomorrow Never Dies crew fleece; and one size "L" suede 007 jacket, not identifiable with a specific production.

**Estimate: £1,000 - 2,000**

**No lot 1331- 1334**



# Day 4

Lots 1335 - End  
November 17, 2024

Online, Telephone and  
Absentee Bidding Only  
3:00 PM (GMT) / 7:00 AM (PST)

Lots on Days 3 and 4 can  
be viewed exclusively in  
the online auction catalog.



**1335**  
Collection of Crew Clothing Items  
and Annotated Scripts †Δ  
**James Bond: Various Productions**

A collection of crew clothing items and scripts from various James Bond films. The three scripts are different drafts of *The World is Not Enough*, featuring handwritten annotations. Crew items for this film are also included, such as a cast and crew bag; two crew fleeces (one "L" and one "S"); two crew polos (one "XL" one "XXL"); and a crew hoodie (size "M"). The remaining crew items are a size "L" *Quantum of Solace* art department crew T-shirt; a crew T-shirt and crew jumper from the production of *A View to a Kill*, both size "L"; and three women's size "L" crew T-shirts and one women's size "XL" from the production of *Skyfall*. Dimensions (script in folder): 31.5 cm x 25.75 cm x 3.25 cm (12.5" x 10" x 1.25")



**Estimate: £500 - 1,000**



**1336**  
Keith Hamshere Collection: Set of Production  
Photographs and Silver Gelatin Promotional Stills †M  
**James Bond: Goldeneye (1995)**

A set of production photographs and promotional stills from Martin Campbell's Bond film *GoldenEye*. This lot comes from the personal collection of renowned stills photographer Keith Hamshere. This set comprises 24 images, most of which are silver gelatin promotional photography featuring stars Pierce Brosnan (James Bond), Sean Bean (Alec Trevelyan), Izabella Scorupco (Natalya Simonova) and Famke Janssen (Xenia Onatopp). One photograph features former Bond actor Roger Moore posing on set with Brosnan. Dimensions (largest): 59.5 cm x 42 cm (23.5" x 16.5") Sold without copyright; see copyright notice in the Buyer's Guide.

**Estimate: £2,000 - 4,000**

**1337**  
Set of Three Hand-drawn Syd Cain Train Artwork †Ω  
**James Bond: Goldeneye (1995)**

Three hand-drawn Syd Cain concept sketches from the production of Martin Campbell's Bond film *GoldenEye*. Eminent art director and production designer Cain worked on many Bond films, including *Dr. No* and *On Her Majesty's Secret Service*, and he is credited as a storyboard artist on *GoldenEye*. He also worked with Alfred Hitchcock as the production designer on *Frenzy*. This lot consists of three pieces of original artwork, all hand-signed by Cain. One depicts Alec Trevelyan's (Sean Bean) train crossing a bridge above a ravine, another depicts Bond (Piers Brosnan) and Natalya Simonova (Izabella Scorupco) jumping off the same bridge as it explodes, and the third depicts the train crashing. The drawings have been created in black and white with mixed media, and are drawn on A3 paper. Dimensions: 43 cm x 30 cm (17" x 12") Sold without copyright; see copyright notice in the Buyer's Guide.

**Estimate: £1,000 - 2,000**

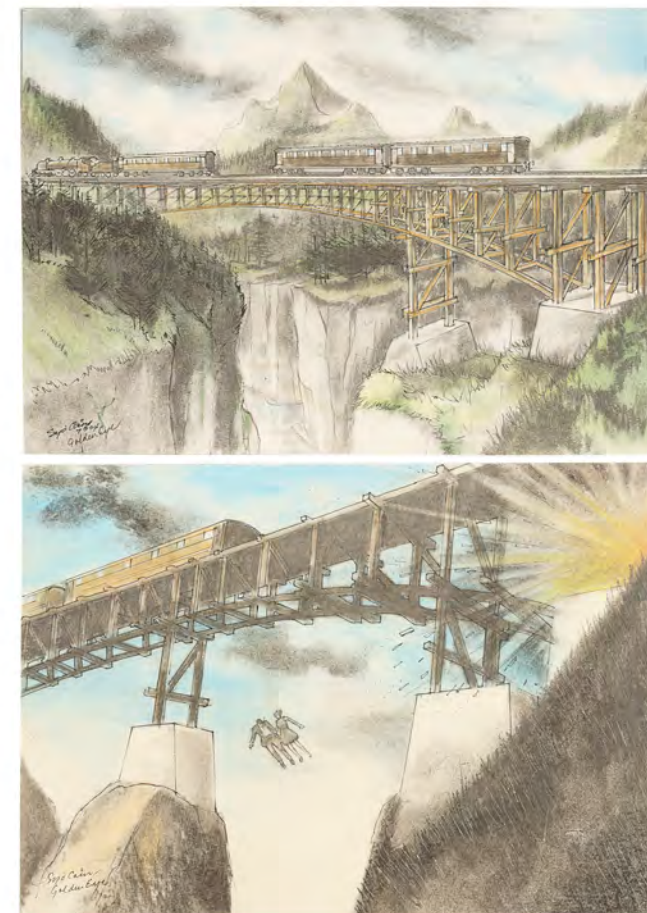

**1338**  
Hand-drawn Syd Cain Train and Bridge Artwork †Ω  
**James Bond: Goldeneye (1995)**

Two hand-drawn Syd Cain concept sketches from the production of Martin Campbell's Bond film *GoldenEye*. Eminent art director and production designer Cain worked on many Bond films, including *Dr. No* and *On Her Majesty's Secret Service*, and he is credited as a storyboard artist on *GoldenEye*. He also worked with Alfred Hitchcock as the production designer on *Frenzy*. This lot consists of two pieces of original artwork, both hand-signed by Cain. One depicts Alec Trevelyan's (Sean Bean) train crossing a bridge above a ravine, the other depicts Bond (Piers Brosnan) and Natalya Simonova (Izabella Scorupco) jumping off the same bridge as it explodes. The drawings have been created with mixed media, and both are drawn on A3 paper. Dimensions: 43 cm x 30 cm (17" x 12") Sold without copyright; see copyright notice in the Buyer's Guide.

**Estimate: £1,000 - 2,000**

**1339**  
Set of Six Hand-drawn Syd Cain  
Storyboards †M  
**James Bond: Goldeneye (1995)**

A set of six hand-drawn Syd Cain storyboards from the production of Martin Campbell's Bond film *GoldenEye*. These storyboards are for the sequence where James Bond (Pierce Brosnan) endeavoured to rescue Natalya (Izabella Scorupco) while she was being held on the missile train by their enemies. Eminent art director and production designer Cain worked on many Bond films, including *Dr. No* and *On Her Majesty's Secret Service*, and he is credited as a storyboard artist on *GoldenEye*. Cain also worked with Alfred Hitchcock as the production designer on *Frenzy*. The storyboards are rendered predominantly in pencil but also with ink embellishments on paper, with some featuring handwritten descriptive labels and Cain's handwritten name. Dimensions (one storyboard): 41.25 cm x 29.75 cm (16.25" x 11.75") Sold without copyright; see copyright notice in the Buyer's Guide.

**Estimate: £1,500 - 3,000**

**No lot 1340**





**1341**  
 Xenia Onatopp's (Famke Janssen)  
 Ferrari Number Plates, Statue Head, Newspapers,  
 and Production Ephemera M  
**James Bond: GoldenEye (1995)**

Xenia Onatopp's (Famke Janssen) Ferrari number plates, a statue head, two newspapers, and other pieces of production ephemera from Martin Campbell's Bond film GoldenEye. During the film's opening, James Bond (Pierce Brosnan) pursued his Ferrari-driving target, Onatopp, in an intense car chase. Later, during another car chase in St. Petersburg, a statue of a knight landed on top of two Russian police cars. The number plates are made of aluminium, while the statue head is fibreglass. The two newspapers were created for production, although they are not obviously seen on screen. The remaining items in the lot comprise 23 on-set Polaroids; two call sheets; a printed storyboard of the police chase sequence displayed in a metal frame; and a promotional brochure for the film. Dimensions (statue head): 25 cm x 37.5 cm x 51.5 cm (9.75" x 14.75" x 20.25")

**Estimate: £2,000 - 4,000**

**1342**  
 Promotional Gadget Phone M  
**James Bond: Tomorrow Never Dies (1997)**

A promotional gadget phone from Roger Spottiswoode's Bond film Tomorrow Never Dies. James Bond (Pierce Brosnan) used his Ericsson phone as he escaped from Elliot Carver's (Jonathan Pryce) headquarters, using his remote-controlled BMW 750i car to evade Carver's guards. This phone, almost identical to the filming version, was created for promotional purposes. Made of resin, the phone features a depressed key layout, branding and a front screen with a static display. A hinge enables the phone to be opened, revealing a touchpad and another screen, this one blank. The phone is presented on a custom-made plastic display stand. Dimensions: 14.5 cm x 5.5 cm x 2 cm (5.75" x 2.25" x 0.75")

**Estimate: £2,000 - 4,000**



**1343**  
 Oversized Water Model Unit Slate M  
**James Bond: Tomorrow Never Dies (1997)**

An oversized water Model Unit slate from the production of Roger Spottiswoode's Bond film Tomorrow Never Dies. This slate was used during the filming of the scenes in which the HMS Chester fired a missile at the weapons bazaar at the beginning of the film, and when the HMS Devonshire was sunk by Elliot Carver's (Jonathan Pryce) stealth ship. These were achieved through model miniatures and shot by the Model Unit. The acrylic slate features the names of unit director John Richardson and miniature photographer Paul Wilson engraved upon it. "Dusk" is handwritten in the box labelled "INT/EXT" and there is adhesive remnants on the back. Dimensions: 35.5 cm x 71 cm x 0.5 cm (14" x 28" x 0.25")

**Estimate: £2,000 - 4,000**

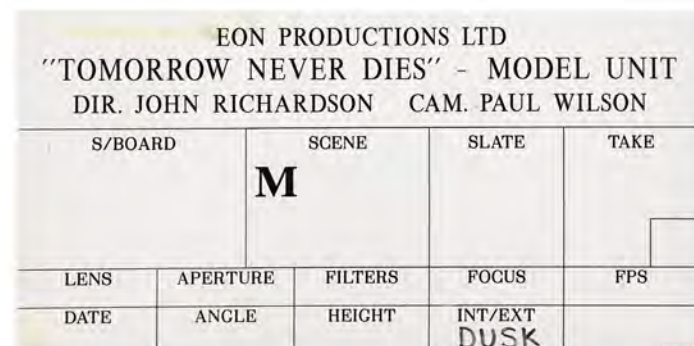

**1344**  
 James Bond's (Pierce Brosnan)  
 Stunt Walther P99 Pistol M  
**James Bond:**  
**Tomorrow Never Dies (1997)**

James Bond's (Pierce Brosnan) stunt Walther P99 pistol from Roger Spottiswoode's Bond film Tomorrow Never Dies. Bond armed himself with a Walther P99 as he and Wai Lin (Michelle Yeoh) infiltrated Elliot Carver's (Jonathan Pryce) stealth boat. The gun is made of hard rubber, crafted so it accurately replicates a genuine P99 by featuring a texturised grip and the weapon's specifications on the barrel. Dimensions: 17.5 cm x 13.5 cm x 2.75 cm (7" x 5.25" x 1") Restricted ownership; see replica firearm notice in the Buyer's Guide.

**Estimate: £2,500 - 5,000**



**1345**  
 Tomorrow Never Dies, The World is Not Enough and  
 Die Another Day Clapperboards M  
**James Bond: Various Productions**

A set of clapperboards from the productions of three James Bond movies starring Pierce Brosnan. The clapperboard from Roger Spottiswoode's Tomorrow Never Dies has "Bond 18" engraved into the top of its acrylic slate, as this was the 18th film in the franchise. It features Velcro straps for the placement of interchangeable badges and retains a badge which reads "1st Unit". "Scenes", "Slate", and "Day-Ext" are handwritten on the slate, and there are numerous labels on which various numbers and letters are handwritten. The clapperboard is missing its sticks. The clapperboard from Michael Apted's The World is Not Enough still has its wooden sticks intact, while the director's name, the name of DoP Adrian Biddle, the film's title and different sections ("scene", "shot", "take", "date") are carved into the acrylic slate and coloured in red. The clapperboard from Lee Tamahori's Die Another Day is smaller than the other two, indicating it was likely used for insert shots. This clapperboard is also missing its sticks. Dimensions (Tomorrow Never Dies clapperboard): 0.5 cm x 30.5 cm x 38.25 cm (0.25" x 12" x 15")

**Estimate: £2,000 - 4,000**



**1346**  
 Victor-III Class  
 Submarine Maquette M  
**James Bond: The World Is Not  
 Enough (1999)**

A Victor-III Class submarine maquette from the production of Michael Apted's Bond film The World is Not Enough. James Bond (Pierce Brosnan) and Dr. Christmas Jones (Denise Richards) successfully controlled the submarine's detonation during the film's climatic scenes after terrorist Renard (Robert Carlyle) unsuccessfully inserted a plutonium rod in the submarine's reactor. The art department produced maquettes when finalising the look of the submarine model for the film, both the full-sized version and any models used for underwater shots. This maquette has a foam interior, with the outer layer made from resin and painted with accurate features. Dimensions: 71.5 cm x 13.75 cm x 14.5 cm (28.75" x 5.5" x 5.75")

**Estimate: £750 - 1,500**





**1347**  
**Q Boat Engine Cover and SFX BMW Bonnet Part †Δ**  
**James Bond: The World Is Not Enough (1999)**

A Q (Desmond Llewelyn) boat engine cover from Michael Apted's Bond film *The World is Not Enough* and a SFX BMW bonnet part from Roger Spottiswoode's Bond film *Tomorrow Never Dies*. In the former, James Bond (Pierce Brosnan) boarded Q's boat and chased the assassin known as Cigar Girl (Maria Grazia Cucinotta) on the Thames River. In the latter, Bond fled his attackers in a BMW that he could control with his gadget cellphone, driving it off a building, which led to its crash in a shop window. The bonnet part has a resin exterior painted to look like a car's body and a fibreglass interior. The bonnet has been intentionally crushed to maintain continuity with the car's crash in the plot. The engine cover is also fibreglass and features velcro stick attachments on its underside. It exhibits wear from production use in the form of minor scratches to its surface. Dimensions (engine cover): 38.5 cm x 34 cm x 13 cm (15.25" x 13.5" x 5")

**Estimate: £1,000 - 2,000**

**1348**  
**Set of Four Zukovsky Casino Chips †Δ**  
**James Bond: The World Is Not Enough (1999)**

A set of four Zukovsky casino chips from Michael Apted's Bond film *The World is Not Enough*. Chips were used in Zukovsky's (Robbie Coltrane) casino, when Bond (Pierce Brosnan) approached his old enemy for advice. This lot comprises one black \$100 chip and three \$500 chips - one pink, one blue and one green. Each plastic chip has a printed picture of Zukovsky on both sides. Dimensions (each): 4 cm x 4 cm (1.5" x 1.5")

**Estimate: £500 - 1,000**



**1349**  
**Cigar Girl's (Maria Grazia Cucinotta) Stunt Boat-mounted Heckler & Koch HK21 Rifle †Δ**  
**James Bond: The World Is Not Enough (1999)**

Cigar Girl's (Maria Grazia Cucinotta) stunt boat-mounted Heckler & Koch HK21 rifle from Michael Apted's Bond film *The World is Not Enough*. A HK21 featured in one of the film's most exciting chase sequences, mounted to the back of the speedboat piloted by Cigar Girl as Bond (Pierce Brosnan) pursued her down the Thames. Cast from resin and hard rubber, the gun is a heavily modified version of a HK21 machine gun with an additional plastic scope and PSG-1 stock. It also has a large rubber ammunition magazine fitted to its underside. The gun is finished in black, brown and white paint. Dimensions: 140 cm x 24 cm x 31 cm (55" x 9.5" x 12.25") Restricted ownership; see replica firearm notice in the Buyer's Guide.

**Estimate: £2,000 - 4,000**



**1350**  
**Hand-drawn Lindy Hemming Design for Elektra King's (Sophie Marceau) Death Scene Dress †Δ**  
**James Bond: The World Is Not Enough (1999)**

A hand-drawn design for Elektra King's (Sophie Marceau) death scene dress from the production of Michael Apted's Bond film *The World is Not Enough*. King wore her costume when she tortured James Bond (Pierce Brosnan), before he escaped and ultimately killed her. This design was created by Academy Award-winning costume designer Lindy Hemming. It is rendered in pencil, ink and watercolour, with purple and silver-coloured inks used for outlining and adding detail. There are various annotations about fabrics and scene references, and information on the costume makers. Hemming has signed the lower right corner, and Marceau's name and "Bond 19" are written along the top. The design displays minor marks, including a green paint mark on its left side. Dimensions: 42 cm x 28.5 cm (16.5" x 11.25") Sold without copyright; see copyright notice in the Buyer's Guide.

**Estimate: £2,000 - 4,000**

**1351**  
**Insert Clapperboard Slate †Δ**  
**James Bond: Die Another Day (2002)**

An insert clapperboard slate from the production of Lee Tamahori's James Bond film *Die Another Day*. The acrylic slate features the title "BOND XX", as well as Tamahori's name and the name of director of photography David Tattersall. It does not come attached to clappers. Dimensions: 15 cm x 13 cm x 0.25 cm (6" x 5" x 0.25")

**Estimate: £800 - 1,600**

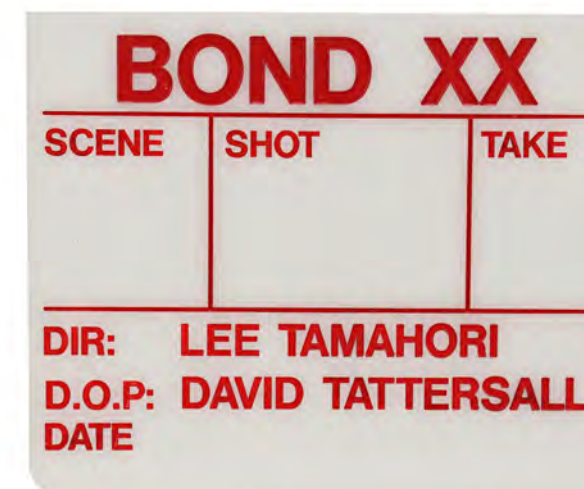

**1352**  
**Peter Nelson Collection: Stunt MP5K, MP5SD, and M16A2 Guns †Δ**  
**James Bond: Die Another Day (2002)**

A stunt MP5K gun, stunt MP5SD gun, and stunt M16A2 gun from Lee Tamahori's Bond film *Die Another Day*. Ice palace guards were armed with MP5K submachine guns, while terrorists attacked James Bond (Pierce Brosnan) with MP5SDs during a training simulation. Both South Korean and US soldiers carried M16A2 rifles throughout the film. The M16A2 is made of resin, while the machine guns are made of rubber. All of the stunt guns contain armatures to maintain their shape. The sight on the MP5SD exhibits chips. Dimensions: (M16A2) 99 cm x 6 cm x 26 cm (39" x 2.25" x 10.25") Restricted ownership; see replica firearm notice in the Buyer's Guide.

**Estimate: £800 - 1,600**

**1353**  
 Peter Nelson Collection: Stunt  
 MP5K, AKS-74U, and AKMS Guns m  
**James Bond:**  
**Die Another Day (2002)**

A stunt MP5K gun, stunt AKS-74U gun, and stunt AKMS gun from Lee Tamahori's Bond film Die Another Day. Ice palace guards were armed with MP5K submachine guns, while Isla Los Organos clinic guards had AKMS guns, and AKS-74U carbines were fought with by James Bond (Piers Brosnan), his comrades, and Colonel Moon's (Will Yun Lee) soldiers. All the guns are made of resin, with armatures running through them to maintain shape. The cocking handle on the MP5K has broken off, and the AKS-74U's sight exhibits chips. The paintwork on the handles of the AKMS that makes them appear like wood is exhibiting peeling. Dimensions: (AKMS) 63.5 cm x 8 cm x 27 cm (25" x 3.25" x 10.75") Restricted ownership; see replica firearm notice in the Buyer's Guide.



**Estimate: £800 - 1,600**

**1354**  
 Screen-matched Secret Bridge-door Key m  
**James Bond: Die Another Day (2002)**

A screen-matched secret bridge-door key from Lee Tamahori's Bond film Die Another Day. James Bond (Pierce Brosnan) was given a key to a door on Westminster Bridge in London, for a secret meeting with M (Judi Dench). Imperfections in the metal screen match this solid steel key to the one seen in the film. Dimensions: 11 cm x 3 cm x 0.5 cm (4.25" x 1.25" x 0.25")

**Estimate: £2,000 - 4,000**



**1355**  
 Aston Martin M16 Owners Manual tΔ  
**James Bond: Die Another Day (2002)**

An Aston Martin M16 owners manual from Lee Tamahori's Bond film Die Another Day. After revealing the Aston Martin V12 Vanquish, Q (John Cleese) handed James Bond (Pierce Brosnan) its manual and asked him to read it. Bond threw the manual in the air, causing the car's automatic machine guns to destroy it. Inside is a detailed printed "V12 Vanquish Owner's Guide" divided into multiple sections, with contents and index pages. The silver-coloured metal folder the manual is contained in exhibits marks, scratches and faded lettering on its front and back. Dimensions: 22.75 cm x 21 cm x 6 cm (9" x 8.25" x 2.5")

**Estimate: £2,000 - 4,000**

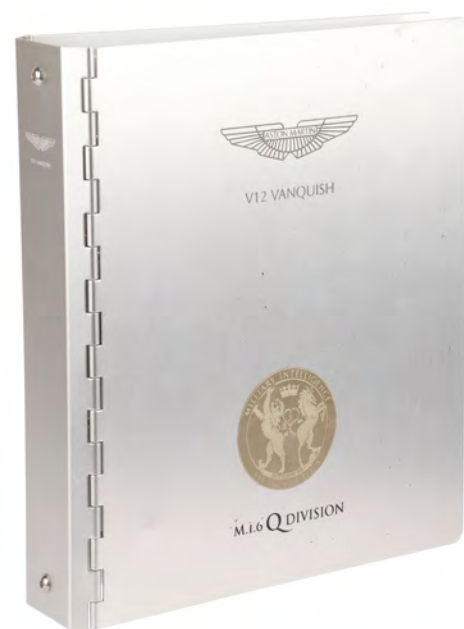

**1356**  
 Pair of Jinx's (Halle Berry)  
 Stunt Knives tΔ  
**James Bond: Die Another Day (2002)**

A pair of Jinx's (Halle Berry) stunt knives from Lee Tamahori's Bond film Die Another Day. Jinx used her throwing knives while fighting Miranda Frost (Rosamund Pike) during the finale, with one knife penetrating a copy of Sun Tzu's The Art of War. The knives are made of resin painted to look like steel. Both exhibit a slight bend in their blades due to production use. Dimensions: 21.75 cm x 4.25 cm x 0.5 cm (8.5" x 1.75" x 0.25")

**Estimate: £1,000 - 2,000**

**1357**  
 Set of Five Martin Asbury Hand-drawn  
 Production Storyboards m  
**James Bond: Die Another Day (2002)**

A collection of Martin Asbury hand-drawn storyboards from Lee Tamahori's spy film James Bond: Die Another Day. Asbury has storyboarded many high-profile films such as 'Labyrinth', 'Interview with the Vampire', 'Alien 3' and two of the Harry Potter features. This collection features 5 pages of hand-drawn and coloured storyboards featuring Zao escaping and Jinx diving off the cliff. The storyboards are annotated, numbered 5-10, and dated "20 Feb 2002". They are rendered onto paper and cardstock in pencil and ink. The shots differ slightly from those in the final cut. Dimensions: 30 cm x 21.5 cm (11.75" x 8.5") Sold without copyright; see copyright notice in the Buyer's Guide.

**Estimate: £2,000 - 4,000**



**1358**  
 James Bond's (Pierce Brosnan) Stunt Submachine Gun m  
**James Bond: Die Another Day (2002)**

James Bond's (Pierce Brosnan) stunt submachine gun from Lee Tamahori's Bond film Die Another Day. Bond used his submachine gun as he tried to escape by hovercraft from a North Korean military base run by Colonel Tan-Sun Moon (Will Yun Lee). This stunt version of an Ingram Military Armament Corp M10 9mm submachine gun is made of rubber. It features such details as an engraved serial number, front and rear sights, a trigger guard, a non-moving safety catch, a non-moving trigger, an engraved barrel, and a large gauge above the trigger. The gun shows some dirt from production, while the front of the barrel and rear sight have been bent out of place. Dimensions: 30 cm x 27 cm x 4 cm (11.5" x 10.75" x 1.75") Restricted ownership; see replica firearm notice in the Buyer's Guide.

**Estimate: £3,000 - 6,000**



**1359**  
Jinx's (Halle Berry) Clinic File m  
**James Bond: Die Another Day (2002)**

Jinx's (Halle Berry) gene-therapy clinic file from Lee Tamahori's Bond film Die Another Day. After assassinating Dr. Alvarez (Simon Andreu), NSA agent Giacinta "Jinx" Johnson burnt her medical record file. The file is made of paper, and its bottom right corner has been burned off, as it was in the film. The file features a photograph of Jinx, as well as her personal information. It is displayed in a wooden frame with plastic cladding, above a production still of Berry as Jinx holding the file. The lot is accompanied by a certificate of authenticity from EON Productions. Dimensions: 70 cm x 41 cm x 2 cm (27.5" x 16.25" x 0.75")

**Estimate: £2,000 - 4,000**



**1360**  
Pair of Vesper Lynd (Eva Green) Business Cards †  
**James Bond: Casino Royale (2006)**

A pair of Vesper Lynd (Eva Green) business cards from Martin Campbell's Bond movie Casino Royale. Treasury agent Vesper Lynd handed her business card to Bond (Daniel Craig) during their initial meeting on the train to Montenegro. Custom-printed for the production, the two identical business cards display several details, embossed metallic red lettering and a royal coat of arms. Dimensions (each card): 5.5 cm x 8.5 cm (2.25" x 3.25")

**Estimate: £400 - 800**

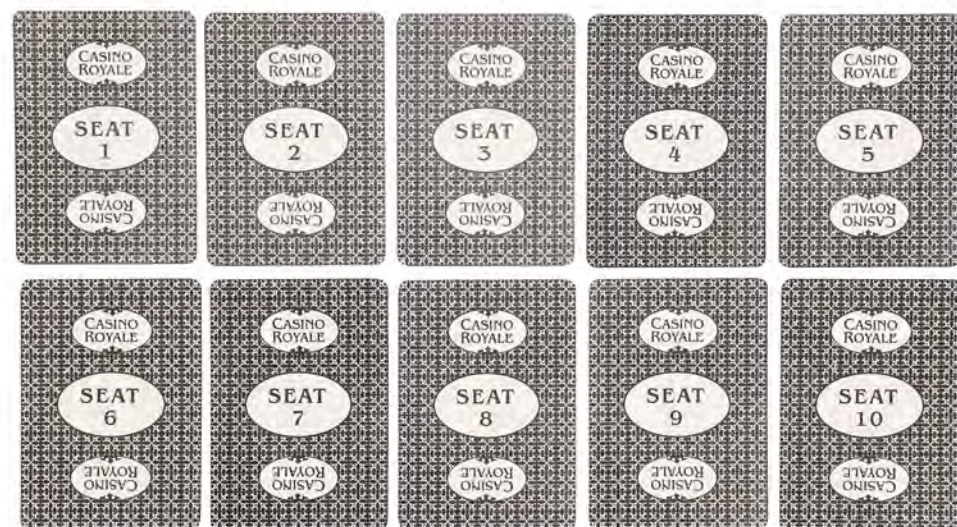

**1361**  
Set of Ten Seat Number Placer Cards †  
**James Bond: Casino Royale (2006)**

A set of ten seat number placers from Martin Campbell's Bond movie Casino Royale. Seat placers were used during rehearsals and are visible in behind-the-scenes reference photos. Each card is labelled "Seat" with a number from one to ten. The opposite side of the cards are blank and display minor marks. Dimensions (each card): 9 cm x 6.5 cm (3.5" x 2.5")

**Estimate: £200 - 400**

**1362**  
Playing Cards and Hotel Splendide Towel m  
**James Bond: Casino Royale (2006)**

A pack of playing cards and a Hotel Splendide towel from Martin Campbell's Bond film Casino Royale. James Bond (Daniel Craig) and villain Le Chiffre (Mads Mikkelsen) played a high-stakes poker game with Casino Royale branded playing cards while staying at the Hotel Splendide. The playing cards remain secured in their plastic packaging. The towel, although not seen on screen, features faux-blood stains. This indicates it was likely designed for use during the scene in Bond's hotel room, where he cleans up his wounds after killing Obanno (Isaach De Bankole) and his bodyguard. Dimensions: (towel) 134 cm x 70 cm x 0.5 cm (52.75" x 27.5" x 0.25")

**Estimate: £500 - 1,000**



**1363**  
Casino Royale Bar Chair †  
**James Bond: Casino Royale (2006)**

A Casino Royale bar chair from Martin Campbell's Bond film Casino Royale. Vesper Lynd (Eva Green), Rene Mathis (Giancarlo Giannini) and others watched the pivotal, high-risk poker match at the Casino Royale in Montenegro. Custom-made for the production, the chair is made of wood and has been finished in faux-gold paint across the frame. The padded seat and back feature leaf-patterned cream covers. The chair displays some wear to the paint finish on the legs and frame. Dimensions: 50 cm x 45 cm x 125 cm (19.75" x 17.75" x 49.25")

**Estimate: £1,000 - 2,000**

**1364**  
Stunt Aston Martin Car Parts and Storyboards m  
**James Bond: Casino Royale (2006)**

Stunt Aston Martin car parts and storyboards from Martin Campbell's spy film James Bond: Casino Royale. Bond (Daniel Craig) crashed his Aston Martin swerving to avoid a bound Vesper Lynd (Eva Green), whilst in pursuit of Le Chiffre (Mads Mikkelsen). Included in this lot are storyboards depicting the aforementioned scene, and parts of the Aston Martin that broke off during the crash, including the instrument cluster hood and one wing mirror. The storyboards are printed in colour, dated "20 May 2006", and feature annotations beside each panel describing the action taking place. Dimensions (hood): 38 cm x 33 cm x 12 cm (15" x 13" x 4.5")

**Estimate: £500 - 1,000**



**1365**  
**B22 "A" Clapperboard**  $\alpha$   
**James Bond: Quantum Of Solace (2008)**

A B22 "A" clapperboard from the production of Marc Forster's Bond film Quantum Solace. This clapperboard features an acrylic white slate with a magnetised black-and-white striped wooden clapper. It is engraved in black with director Marc Forster's and director of photography Roberto Schaefer's names, and the fields "Roll," "Scene," "Take," "Date," "Filter," "INT/EXT," and "DAY/NIGHT." The date features a hand-marked "08" in black marker. There are faint markings in the fields for "38" and "5." This clapperboard exhibits scratches in the acrylic, black scuffing, and chipped paint. Dimensions: 28 cm x 2.75 cm x 24.25 cm (11" x 1" x 9.5")

**Estimate: £2,000 - 4,000**



**1366**  
**Set of Three Prototype Floating Dragon Casino Chips**  $\triangle$   
**James Bond: Skyfall (2012)**

A set of three prototype Floating Dragon Casino chips from the production of Sam Mendes' Bond film Skyfall. After killing Patrice (Ola Rapace), James Bond (Daniel Craig) acquired the Floating Dragon Casino chip in the assassin's possession. Bond exchanged this chip at the casino for a case of more chips, intended as Patrice's reward for a recent job. These prototype chips are made of plastic and barely differ from the one seen on screen, which suggests they were created towards the end of the design process for this prop. Dimensions: 5 cm x 5 cm x 0.5 cm (2" x 2" x 0.25")

**Estimate: £600 - 1,200**

**1367**  
**Collection of Crew Items**  $\mathfrak{M}$   
**James Bond: Skyfall (2012)**

A collection of crew clothing and accessories from the production of Sam Mendes' Bond film Skyfall. The lot consists of a black flat cap (Size S/M); a black "Second Unit UK & Turkey 2012" T-shirt (size XXL); a green "Location Department" T-shirt (size XL); a blue "Armoury Dept 2012" T-shirt (size XL); a yellow V-necked "Transport Team, Turkiye 2012" T-shirt (size XXL); a navy "2nd Unit Camera Department 2012" T-shirt (size XXL); two blue "VFX" T-shirts (size L and 2XL); two grey "Made In Turkiye" T-shirts (size XXL); and two black "The Ultimate Arm Film Crew" T-shirts (sizes XL and XXL). One of the VFX t-shirts has faded, and the lot exhibits some minor marks.

**Estimate: £1,000 - 2,000**

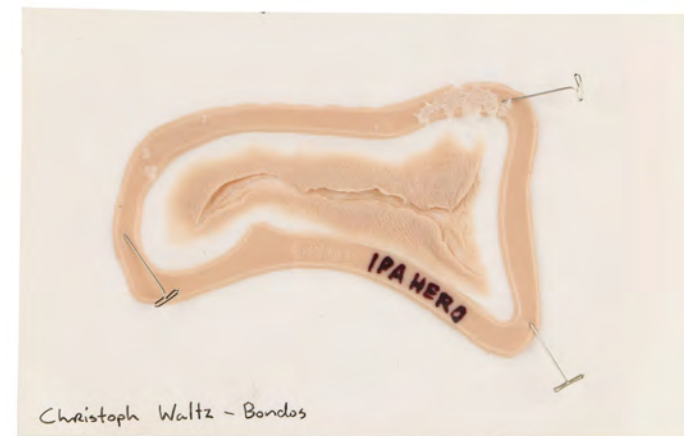

**1368**  
**Ernst Stavro Blofeld's (Christopher Waltz) Scar Prosthetic**  $\mathfrak{M}$   
**James Bond: Spectre (2015)**

Ernst Stavro Blofeld's (Christopher Waltz) scar prosthetic from Sam Mendes' Bond film Spectre. Blofeld obtained a gruesome scar from an explosion during James Bond (Daniel Craig) and Madeleine Swann's (Lea Seydoux) successful escape from the Spectre leader's base. This latex prosthetic is adhered to a piece of Polystyrene that features "Christopher Waltz-Bondos" handwritten in black ink on its surface. "IPA HERO" has also been handwritten in black ink on the latex border surrounding the prosthetic. Dimensions: 20.25 cm x 13 cm x 1.5 cm (8" x 5" x 0.75")

**Estimate: £500 - 1,000**

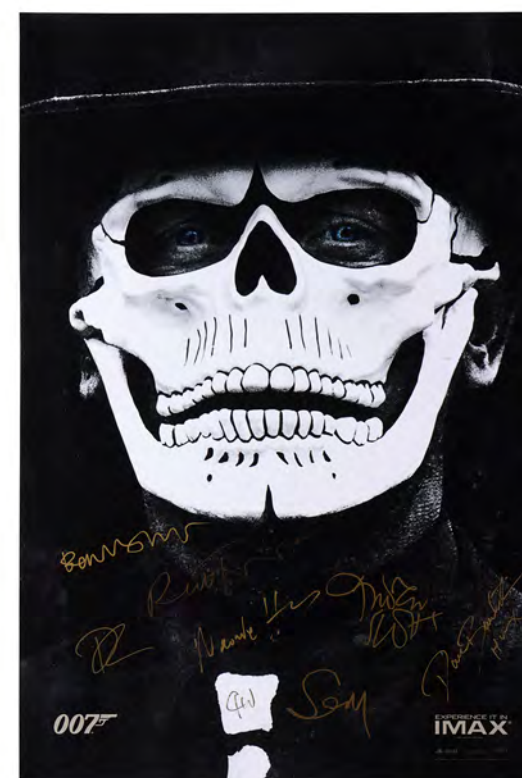

**1369**  
**Daniel Craig, Christoph Waltz and Cast-Autographed Day of the Dead Poster**  $\mathfrak{M}$   
**James Bond: Spectre (2015)**

A Day of the Dead poster from the promotion of Sam Mendes' Bond film Spectre, signed by leading cast members. The poster, which depicts Bond in his Day of the Dead skull-faced costume, is signed with autographs in gold marker by Daniel Craig (James Bond), Christoph Waltz (Blofeld), Ralph Fiennes (M), Naomie Harris (Money Penny), Ben Whishaw (Q), Andrew Scott (C), Dave Bautista (Hinx), and Mendes. Dimensions: 101.25 cm x 69 cm (39.75" x 27.25") The handwriting in this lot has been professionally authenticated by expert Garry King; see notice in the Buyer's Guide.

**Estimate: £1,000 - 2,000**



**1370**  
**James Bond's (Daniel Craig) Prototype Dia de los Muertos Mask**  $\alpha$   
**James Bond: Spectre (2015)**

James Bond's (Daniel Craig) prototype Dia de los Muertos mask from Sam Mendes' James Bond: Spectre. Bond wore his mask as he walked through the streets of Mexico City during the Dia de los Muertos celebration while attempting to stop a bombing at the local stadium. The 24th film in the 007 franchise, Spectre broke several records in its release, including a Guinness World Record for Largest Film Stunt Explosion. It completed its theatrical run as the second highest-grossing Bond film of all time, and later received an Academy Award® for its introductory song. This style of mask was created by production as a prototype for the version ultimately seen in the final cut. Made from plastic, the mask is painted white with black skull-patterned detailing, lined with black foam, and affixed with a black elastic headband for securing to the wearer's head. It exhibits some discolouration on the interior and notable adhesive along the lining.

**Estimate: £4,000 - 8,000**





**1371**  
James Bond (Daniel Craig) Target Sheet  $\Omega$   
**James Bond: Spectre (2015)**

A James Bond (Daniel Craig) target sheet from Sam Mendes' James Bond: Spectre. Blofeld (Christoph Waltz) lured Bond through an abandoned MI6 building decorated with target-practice sheets featuring images of the super-spy's face, as seen in the opening of Mendes' Skyfall. This large black-and-white paper sheet labelled "5x" over a body silhouette with target marks is applied at top with a picture of Bond's face and backed with foam core. It exhibits some staining and folding to its corners from production and handling. Dimensions: 106 cm x 61 cm (41.75" x 24")

**Estimate: £1,500 - 3,000**



**1372**  
Hand-numbered Limited Edition 2013 Jaws Screen Print by Laurent Durieux  $M$   
**Jaws (1975)**

A highly sought-after limited edition alternative movie poster created by artist Laurent Durieux for Steven Spielberg's thriller Jaws. Durieux's unique style is instantly identifiable, with his creations numbering among the most desirable artworks in the alternative movie poster market. This design is one of those most coveted by collectors. It was released in 2013 through Mondo and even attracted the attention of Spielberg himself, who allegedly ordered 25 copies to give to close friends and family. Durieux created this image as a contrast to Roger Kastel's iconic shark design for the original marketing campaign. The postcard-esque scene appears idyllic, yet the black panel on the beach umbrella creates a feeling of unease. Printed by DL Screenprinting, this poster is hand-numbered 54 out of 525. Dimensions: 91.5 cm x 61 cm (36" x 24")

**Estimate: £3,000 - 6,000**



**1373**  
David Frangioni Collection: US Subway - "Now Playing" Style, 1975  $\Omega$   
**Jaws (1975)**

A US Subway poster from the release of Steven Spielberg's Jaws. The late Roger Kastel's most famous artwork is truly a sight to behold in this large US Subway format. In the run up to Jaws' blockbuster release in 1975 these posters for were printed in three different versions: an undated Advance, a dated Advance and a "Now Playing" style. The design on offer here is the "Now Playing" style. The poster is conservation linen-backed with fold line restoration and a couple of tiny surface scuffs post-restoration. It remains in a very fine condition. Dimensions: 150 cm x 116 cm (59" x 45.5")

**Estimate: £1,500 - 3,000**

**1374**  
David Frangioni Collection: US Subway Advance Poster, No Credits - Linen-Backed, 1975  $\Omega$   
**Jaws (1975)**

A US Subway poster from the release of Steven Spielberg's Jaws. The late Roger Kastel's most famous artwork is truly a sight to behold in this large US Subway format. In the run up to Jaws' blockbuster release in 1975 these posters for were printed in three different versions: an undated Advance, a dated Advance and a "Now Playing" style. The design on offer here is the undated Advance style. This example is unrestored with handling and surface wear as well as nicks and tears around the border and down the middle some of which have been repaired with tape on the reverse. It remains in a fine condition. Dimensions: 150 cm x 116 cm (59" x 45.5")

**Estimate: £1,000 - 2,000**

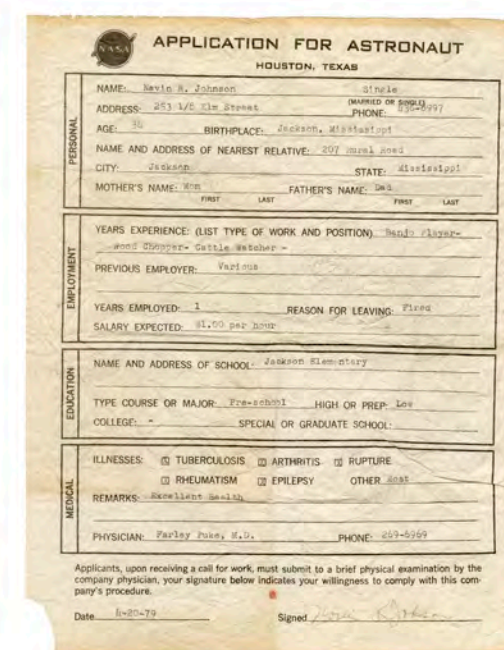

**1375**  
Navin Johnson's (Steve Martin) Astronaut Application  $\Omega$   
**The Jerk (1979)**

Navin Johnson's (Steve Martin) astronaut application from Carl Reiner's The Jerk. Johnson provided two forms of identification, his temporary driver's licence and his failed astronaut application form, when he went to the bank with his cashier's check for "two hundred and fifty big ones," which he soon realised was actually \$250,000. This application is printed with the header "Application for Astronaut Houston, Texas" featuring a NASA logo, typed answers to the application questions, and is dated and signed "4-20-79 Navin R. Johnson." It was folded and crumpled by production as it was meant to have been kept in Johnson's wallet. It exhibits some staining, edge wear, and a torn corner from use and age. Dimensions: 21.5 cm x 27.5 cm (8.5" x 10.75")

**Estimate: £1,200 - 2,400**



**1376**  
Jerry Maguire's (Tom Cruise) Framed Pair of Business Cards  $\Omega$   
**Jerry Maguire (1996)**

Jerry Maguire's (Tom Cruise) framed pair of business cards from Cameron Crowe's Jerry Maguire. After Sports Management International (SMI) let him go for disseminating a mission manuscript to change the business, Maguire started his own company, the Jerry Maguire Company Sports Management Consultants, for which he had new business cards made. This lot consists of one custom cardstock SMI business card and one from the Jerry Maguire Company, both mounted in a custom black wooden frame labelled with the film's title alongside a colour-printed colour image of the poster. The title exhibits fading colour and the frame exhibits minor scuffing from handling. Dimensions: 38 cm x 30 cm x 1.5 cm (15" x 11.75" x 0.5")

**Estimate: £800 - 1,600**

**1377**  
**Folders, Business Cards, Beer Glass, and Cassette with Behind The Scenes Photo and Parking Pass**  
**Jerry Maguire (1996)**

Folders, business cards, a beer glass, and cassette with a behind-the-scenes photo and parking pass from Cameron Crowe's Jerry Maguire. Jerry Maguire (Tom Cruise) worked for Sports Management International representing sports clients before he was fired and opened his own sports management company. Created by property master Hope Parrish, this lot consists of four folders for SMI, NFL, Jerry Maguire Company, and "The Things We Think and Do Not Say," each filled with production-made paperwork; six cardstock business cards for Jerry Maguire, Bob Sugar (Jay Mohr), the NFL, and SMI; a laminated sports card for Calvin Nack (Brent Barry); a colour Polaroid image of Jerry and Dorothy Boyd (Renee Zellweger) at their wedding; a clear glass beer tumbler with SMI in blue vinyl; and a Jerry Maguire parking placard adhered to an illustration board. This lot exhibits edge wear to the folders and parking placard.

Dimensions: (largest) 23 cm x 29.25 cm x 0.75 cm (9" x 11.5" x 0.25")

**Estimate: £500 - 1,000**



**1378**  
**Henson Kermit Crew Gift and Workshop Casting m**  
**Jim Henson Productions**

A Henson Kermit crew gift and workshop casting made by the Jim Henson Company, who produced the Muppets series of films and television series. Included in this lot is a sterling silver Kermit keyring and a resin cast of Kermit. The cast, for a proposed toy line, is unpainted, and features Kermit sat atop a log with a banjo by his feet. The keyring has a "Sterling" engraving on the underside of one of Kermit's feet and comes in a gauze pouch. It exhibits minor tarnishing, but otherwise both items remain in excellent condition.

Dimensions: 21 cm x 9 cm x 9 cm (8.25" x 3.5" x 3.5")

**Estimate: £500 - 1,000**

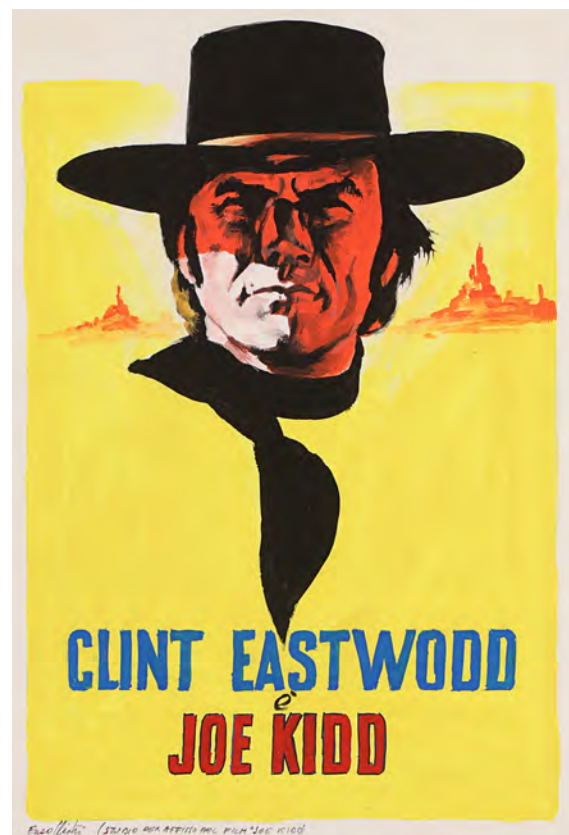

**1379**  
**Enzo Nistri Hand-painted Italian Poster Concept Art m**  
**Joe Kidd (1972)**

Italian poster concept art hand-painted by Enzo Nistri for John Sturges' Western Joe Kidd. In the film, former bounty hunter Joe Kidd (Clint Eastwood) reluctantly agrees to help landowner Frank Harlan (Robert Duvall) hunt down Mexican revolutionary leader Luis Chama (John Saxon). The final version of this design was used for the film's posters in Italy. Nistri has signed his name in black ink in the bottom border of the piece, which is rendered on paper and displayed in a wooden frame. Dimensions: 54.5 cm x 43.5 cm x 4 cm (21.5" x 17.25" x 1.5") Sold without copyright; see copyright notice in the Buyer's Guide.

**Estimate: £3,000 - 6,000**



**1380**  
**Helium Cleaver Sword †**  
**John Carter (2012)**

**1380**  
**Helium Cleaver Sword †**  
**John Carter (2012)**

A Helium cleaver sword from Andrew Stanton's sci-fi action film John Carter. Civil War veteran John Carter (Taylor Kitsch) used a cleaver sword while rescuing Dejah Thoris (Lynn Collins), princess of the besieged city of Helium on Mars. The cleaver-style sword is double-bladed and has a hand-carved wooden grip, around which a brown leather strap is wrapped. The blades are made of silver resin and feature straight spines, curved edges and multiple engravings exhibiting a star chart motif. The blades are intentionally tarnished to look used, and their edges are dulled for safety. The lot exhibits signs of production wear but remains in good condition. Dimensions: 48 cm x 11 cm x 3 cm (19" x 4.25" x 1.25")

**Estimate: £1,500 - 3,000**

A hero Zodangan gun from Andrew Stanton's sci-fi action film John Carter. After being transported to Mars, Civil War veteran John Carter (Taylor Kitsch) became embroiled in a war between the cities of Zodanga and Helium. The Zodangan gun has a hand-carved wooden stock, grip and handguard attached to a metal shaft and barrel. Dual perpendicular wooden faux drum magazines are located at the gun's midpoint, each displaying a patterned gold-coloured resin face. The gun also has a gold-coloured resin trigger guard, a leather buckle strap and a faux bolt handle. The barrel and metal shaft exhibit some rusting. Dimensions: 97 cm x 24.5 cm x 24 cm (38.25" x 9.75" x 9.5") Firearm deactivated; see firearm deactivation notice in the Buyer's Guide.

**Estimate: £2,000 - 4,000**

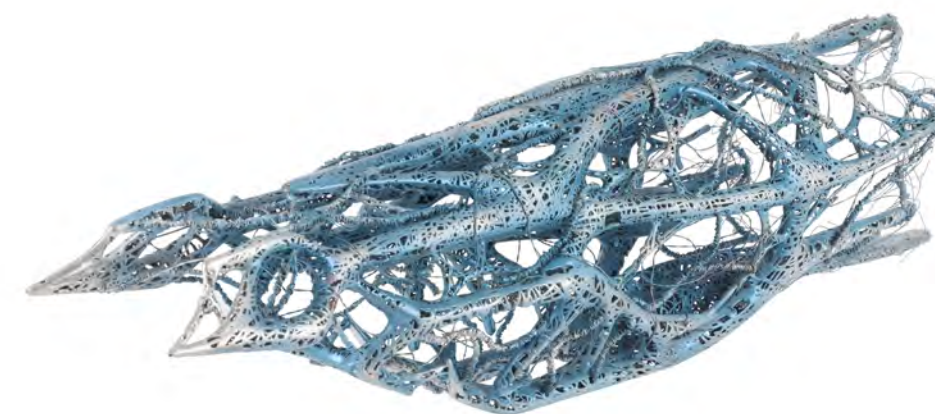

**1382**  
**Sab Than's (Dominic West) Gauntlet Weapon m**  
**John Carter (2012)**

Sab Than's (Dominic West) gauntlet weapon from Andrew Stanton's sci-fi action film John Carter. Sab Than fought with the weapon throughout the film after it was gifted to him by the Thern leader, Matai Shang (Mark Strong). The weapon is crafted from metal and plastic and painted an ethereal blue. Dimensions: 61 cm x 18 cm x 14 cm (24" x 7" x 5.5")

**Estimate: £1,500 - 3,000**



**1383**  
Thern Medallion m  
**John Carter (2012)**

A Thern medallion from Andrew Stanton's sci-fi adventure film John Carter. Therns such as Matai Shang (Mark Strong) used their medallions to teleport between locations, and John Carter (Taylor Kitsch) used one to return to Barsoom from Earth at the end of the film. This aluminium pendant features a pearlescent resin core, giving it a shimmering appearance. It has been intentionally distressed to appear well-used and weathered.

Dimensions: 12 cm x 9.5 cm x 2.5 cm (4.75" x 3.75" x 1")

**Estimate: £4,000 - 8,000**



**1384**  
Thern Bracelet m  
**John Carter (2012)**

A Thern bracelet from Andrew Stanton's sci-fi adventure film John Carter. Therns such as Matai Shang (Mark Strong) wore bracelets and used them to control people and objects. The aluminium bracelet features a pearlescent resin core, giving it a shimmering appearance. It has been intentionally distressed to appear well-used and weathered.

Dimensions: 8.5 cm x 4.5 cm x 6 cm (3.25" x 1.75" x 2.25")

**Estimate: £1,500 - 3,000**



**1385**  
Male Zodangan Warrior Armor m  
**John Carter (2012)**

A Zodanga warrior armour and uniform from Andrew Stanton's John Carter. Zodanga warriors wore their armour as they chased Princess Dejah Thoris (Lynn Collins). This lot consists of red poly-cotton underwear labelled "34"; a dark red leather skirt marked "MZ S1"; red- and black-painted rubber shin guards marked "ML MR MZ 104"; black leather boots with brown-painted rubber covers labelled "518"; brown leather, metal, and urethane body armour with a red poly-cotton cape and shoulder covering marked "MR" and "ZS 237 MZ S10 ADAM HART" for stunt performer Adam Hart. This lot exhibits minor discolouration and grime.

**Estimate: £1,200 - 2,400**

# Propstore



**Sell Your  
Movie Memorabilia**  
Achieve world record prices for  
entertainment memorabilia



**Jurassic World (2015)**  
Distressed Jurassic Park  
Hard Hat

**sold for \$5,670 (£4,536)\***

Reach out for a free appraisal  
and valuation with our specialists

 Email: [consign@propstore.com](mailto:consign@propstore.com)  
 Propstore UK Office: +44 (0) 1494 766485  
 US Office: +1 818 727 7829

Scan QR code to visit [propstore.com/props](http://propstore.com/props)





**1386**  
John Wick's (Keanu Reeves) Suit  $\Omega$   
**John Wick: Chapter 3 - Parabellum (2019)**

John Wick's (Keanu Reeves) suit from Chad Stahelski's John Wick: Chapter 3 - Parabellum. John wore his signature suit in various iterations after returning to New York following his being rendered excommunicado by the High Table. This costume consists of a black wool Calvin Klein jacket (Size 42R) labelled "42"; a black silk Club Room tie labelled "JW Stunt"; a black cotton-blend Beckenstein Bespoke long-sleeve, button-down shirt; matching black cotton-blend trousers labelled "Jackson" for Reeves' stunt double; a pair of black metal oval shaped cufflinks in a brown leather storage box; and a pair of black leather Calvin Klein dress shoes (Size 44 EU, 11 U.S.). The costume exhibits loose threads on the jacket from wear.

**Estimate: £1,500 - 3,000**



**1387**  
Collection of Prop and Weapon Replicas  $m$   
**John Wick Franchise**

A collection of replica props and weapons from Chad Stahelski's John Wick franchise. The large collection includes replicas of some of John Wick's (Keanu Reeves) personal items and some of the weapons used to mete out pain and destruction throughout the franchise. The replica props include a collection of coins, John's rosary, two blood oath markers, John's Ruska Roma medallion, gold ingots, a bloody pencil, and paperwork including photographs of John and his wife Helen (Bridget Moynahan) and John's certificate of excommunication. The weapons include knives, various pistols, an assault rifle, a pump action shotgun, a grenade launcher, various knives, various grenades, a claymore, and dynamite. The collection is held in a trunk decorated with more photographs and paperwork from the franchise. The claymore is currently in two separate pieces. Dimensions: 51 cm x 91 cm x 36 cm (20" x 35.75" x 14.25) Restricted ownership; see replica firearm notice in the Buyer's Guide.

**Estimate: £3,000 - 6,000**



**1388**  
John Wick's (Keanu Reeves) Suit  $m$   
**John Wick: Chapter 2 (2017)**

John Wick's (Keanu Reeves) suit from Chad Stahelski's action sequel John Wick: Chapter 2. Wick wore his suit for the second half of the film, after he returned to New York City and Santino D'Antonio (Riccardo Scamarcio) put out a hit on him, causing dozens of hitmen and women to attack him. The suit comprises a black, single-breasted Ike Behar jacket and matching trousers; a white Beckenstein shirt; and a black silk tie. The suit jacket has a label in the inside left pocket with "Hero" handwritten on it. The costume has been intentionally distressed, including dirt markings, and there is a hole inside the suit jacket by the inside right pocket.

**Estimate: £4,000 - 8,000**

**1389**  
Set of Five High Table Coins  $\Delta$   
**John Wick: Chapter 4 (2023)**

Five High Table coins from Chad Stahelski's action sequel John Wick: Chapter 4. High Table members used a unique currency. Tracker (Shamier Anderson) paid for a hotel room at the Osaka Continental with a gold coin, and Killa (Scott Adkins) sat at his poker table adorned with stacks of the currency. The coins are made of plastic and finished to look like gold, with emblems embossed on each side. One coin exhibits orange-coloured staining on part of its side. Dimensions (one coin): 4 cm x 4 cm x 0.25 cm (1.5" x 1.5" x 0.25")

**Estimate: £2,000 - 4,000**



**1390**  
Set of Five High Table Coins  $\Delta$   
**John Wick: Chapter 4 (2023)**

Five High Table coins from Chad Stahelski's action sequel John Wick: Chapter 4. High Table members used a unique currency. Tracker (Shamier Anderson) paid for a hotel room at the Osaka Continental with a gold coin, and Killa (Scott Adkins) sat at his poker table adorned with stacks of the currency. The coins are made of plastic and finished to look like gold, with emblems embossed on each side. Dimensions (one coin): 4 cm x 4 cm x 0.25 cm (1.5" x 1.5" x 0.25")

**Estimate: £2,000 - 4,000**



**1391**  
John Wick's (Keanu Reeves) Stunt Osaka Continental Katana and Nunchaku  $\Delta$   
**John Wick: Chapter 4 (2023)**

John Wick's (Keanu Reeves) stunt Osaka Continental katana and nunchaku from Chad Stahelski's action sequel John Wick: Chapter 4. John wielded various weapons as he fought off Caine (Donnie Yen) and The Myrmidons during their assault on the Osaka Continental. The katana comprises a bamboo blade finished to look like metal; a rubber guard painted to look like gold; and a resin hilt wrapped in tough cotton to resemble Tsuka-ito (Japanese cotton). The nunchaku is made of rubber with a paint finish to make its pair of shafts look like wood and the rivets like metal. Metal hooks are attached to the end of each rivet - these were used to connect the sticks by a chain, which is not present. The blade exhibits a minor scuff on one side, while the guard is slightly bent. Dimensions: 106.25 cm x 8.75 cm x 7.75 cm (41.75" x 3.5" x 3")

**Estimate: £3,000 - 6,000**





**1392**  
Caine's (Donnie Yen) Cane Sword  
and Stunt Blade †Δ  
**John Wick: Chapter 4 (2023)**

Caine's (Donnie Yen) cane sword and stunt blade from Chad Stahelski's action sequel John Wick: Chapter 4. Blind assassin Caine used a sword hidden in his cane as his primary weapon throughout the film. The lot comprises of an aluminium-bladed sword with the tip intentionally removed, and a wooden stunt blade designed to look like steel. Dimensions (metal sword): 81.5 cm x 4.5 cm x 4.5 cm (32" x 1.75" x 1.75")

**Estimate: £1,500 - 3,000**

**1393**  
Osaka Continental Bow  
with Arrows †Δ  
**John Wick: Chapter 4 (2023)**

An Osaka Continental bow with two arrows from Chad Stahelski's action sequel John Wick: Chapter 4. Armed with bows and arrows, Akira (Rina Sawayama) and the Osaka Continental hotel staff fought The Myrmidons as they attempted to assassinate John Wick (Keanu Reeves). The bow is made of rubber painted to look like red wood and metal. The string is predominantly rubber, with its ends wrapped in thin rope that allows it to be strung at either end of the bow. The bow's grip has been wrapped with tough cotton to resemble Tsuka-ito (Japanese cotton). The two arrows comprise alloy shafts, metal points, and plastic fletchings and knocks. Dimensions: (bow strung) 123.5 cm x 35.5 cm x 5 cm (48.5" x 14" x 2")

**Estimate: £1,000 - 2,000**



**1394**  
Judy Garland's (Renee Zellweger)  
Fur Coat †  
**Judy (2019)**

Judy Garland's (Renee Zellweger) fur coat from Rupert Goold's biopic Judy. Judy wore her fur coat throughout the film in several key scenes. The coat is made of faux fur and features an embedded faux leather belt. A wire inside the left-sided pocket threads through into the inner lining. This wire was likely placed here to facilitate a microphone, thus enhancing the sound quality of Judy's dialogue when wearing the coat.

**Estimate: £1,000 - 2,000**



**1395**  
Judy Garland's (Renee Zellweger)  
Heckled Performance Dress †  
**Judy (2019)**

Judy Garland's (Renee Zellweger) heckled performance dress from Rupert Goold's biopic Judy. Physical and mental exhaustion marred Judy's performance at one of her sold-out shows, leading to her being heckled by audience members and eventually passing out on stage. During this performance, she wore a multi-coloured floral patterned ankle-length dress with pink heeled shoes. The dress features a costume label with "Renee Zellweger" handwritten in black ink. The L.K. Bennett London shoes accompanying the dress are UK size "37".

**Estimate: £1,000 - 2,000**



**1396**  
Judy Garland's (Renee Zellweger)  
Photo and Screen-matched  
Poster Dress †  
**Judy (2019)**

Judy Garland's (Renee Zellweger) photo and screen-matched poster dress from Rupert Goold's biopic Judy. The dress screen-matches by its floral patterns precisely aligning with one another, photo-matching the same way with one of the main promotional posters for the film. Judy wore a colourful floral dress as she was escorted to the theatre for a sold-out show. When she arrived, she expressed her wish not to go on stage but was coerced by her assistant, Rosalyn Wilder (Jessie Buckley). Zellweger won an Oscar and a BAFTA in the Best Actress category for her captivating performance of the loved and revered 20th-century cultural icon, Judy Garland.

**Estimate: £3,500 - 7,000**



**1397**  
Pair of Parrish Shoeboxes Ω  
**Jumanji (1995)**

A pair of Parrish shoe boxes from Joe Johnston's Jumanji. Alan Parrish's father, Sam, owned the Parrish Shoe company where shoes were placed in assembled striped cardboard boxes before sale. These shoeboxes, consisting of a lid and base, are made of two-tone cardboard with a white surface and brown interior. It features production-made foldlines and perforations, and pear-colour stripes on the exterior sides with a Parrish Shoe logo on the top and on the width sides. This lot exhibits some curling of the edges, creasing on the flaps, and some discolouration. Dimensions: (each) 16.5 cm x 34.5 cm x 11.5 cm (6.5" x 13.5" x 4.5")

**Estimate: £1,200 - 2,400**

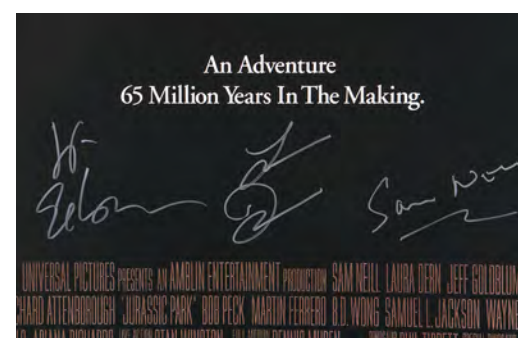
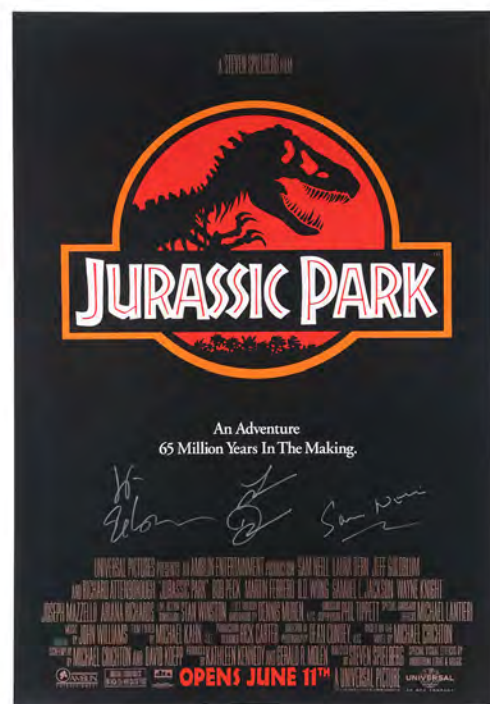

**1398**  
 Jeff Goldblum, Sam Neill and Laura Dern—Autographed One Sheet †Δ  
**Jurassic Park (1993)**

A poster autographed by three principal cast members of Steven Spielberg's Jurassic Park. This poster, which displays the Advance One Sheet design for the first movie, has been autographed in silver ink by Jeff Goldblum (Dr Ian Malcolm), Sam Neill (Dr Alan Grant) and Laura Dern (Dr Ellie Sattler). It is in a rolled condition. Dimensions: 99 cm x 69 cm (39" x 27") The autographs in this lot have been professionally authenticated by expert Garry King; see notice in the Buyer's Guide.

**Estimate: £600 - 1,200**



**1399**  
 Hand-painted Amber Digging Animation Cel with Hand-drawn Sketch M  
**Jurassic Park (1993)**

A hand-painted amber digging animation cel with a hand-drawn sketch from the production of Steven Spielberg's Jurassic Park. John Hammond (Richard Attenborough) presented Dr. Alan Grant's (Sam Neill) team with an animated film explaining how dinosaur DNA was extracted from amber. This lot consists of a hand-painted mylar plastic animation cel depicting an amber tunnel hand-drawn in mixed media on paper numbered "Sc3A," "W/W GR4," "69," and "12FC." Both are hole-punched, and the sketch exhibits pinholes and creasing from production. Dimensions: 31.75 cm x 26.75 cm (12.5" x 10.5") Sold without copyright; see notice in the Buyer's Guide.

**Estimate: £3,000 - 6,000**

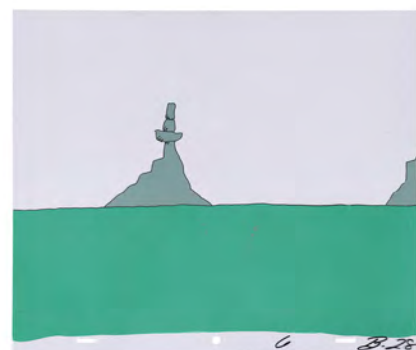

**1400**  
 Hand-Painted Mr. DNA (Greg Burson) Diggers Animation Cel with Hand-drawn Sketch M  
**Jurassic Park (1993)**

A Mr. DNA (Greg Burson) diggers animation cel from the production of Steven Spielberg's Academy Award-winning sci-fi action-adventure Jurassic Park. Mr. DNA was the mascot for John Hammond's (Richard Attenborough) introductory video, where he explained how he bioengineered the dinosaurs. During this video, two animated men dug until they found a mosquito fossil. This lot comprises two transparent acetate cels, one featuring hand-painted images of the diggers tunnelling and the other depicting rocky formations on a green Earth. "3.A 52.A" is handwritten on the diggers cel, while "3.A B.28" is handwritten on the rocky formations cel. Both markings are in black ink. A piece of paper presenting a tree trunk, hand-sketched in pencil, is also included. Dimensions: 32 cm x 27 cm (12.5" x 10.75") Sold without copyright; see copyright notice in the Buyer's Guide.

**Estimate: £1,500 - 3,000**

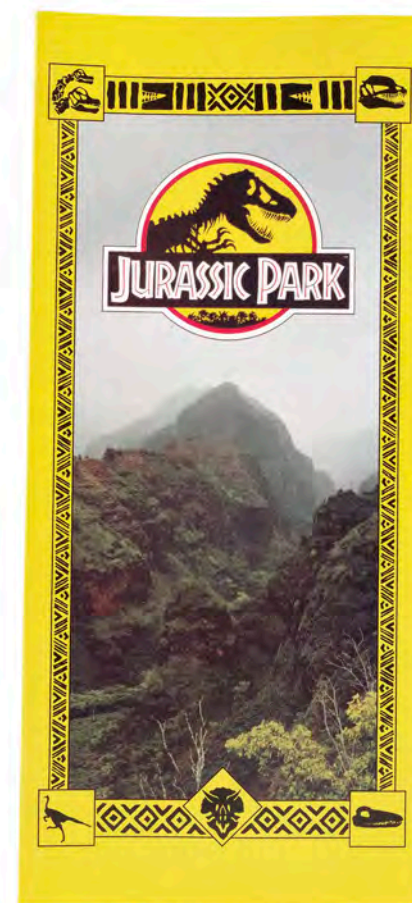

**1401**  
 Park Visitor Brochure Ω  
**Jurassic Park (1993)**

A park visitor brochure from Steven Spielberg's Jurassic Park. The park's brochures appeared at various locations throughout the film, including the Visitor Center and within the Ford Explorer tour vehicles. Jurassic Park won a total of three Academy Awards® for Best Sound Effects Editing awarded to Gary Rydstrom and Richard Hymns, Best Sound to Gary Summers, Gary Rydstrom, Shawn Murphy and Ron Judkins, and Best Visual Effects to Dennis Muren, Stan Winston, Phil Tippett and Michael Lantieri. The film also won three Saturn Awards to Steven Spielberg for Best Director, Best Science Fiction Film, and Best Special Effects to Dennis Muren, Stan Winston, Phil Tippett, and Michael Lantieri. This double-sided, glossy paper brochure features a printed map of Jurassic Park on one side, pinpointing different sites on the island including the Visitor Center, helipad, dinosaur enclosures, and electric fences. The reverse shows a printed drawing of the park gates with general information, including a section in Japanese, a camera film advertisement, and a mountain terrain photograph that forms the front cover. The brochure exhibits creasing and minor warping from age. Dimensions: (folded) 21 cm x 9.5 cm x 0.75 cm (8.25" x 4" x 0.25")

**Estimate: £2,000 - 4,000**

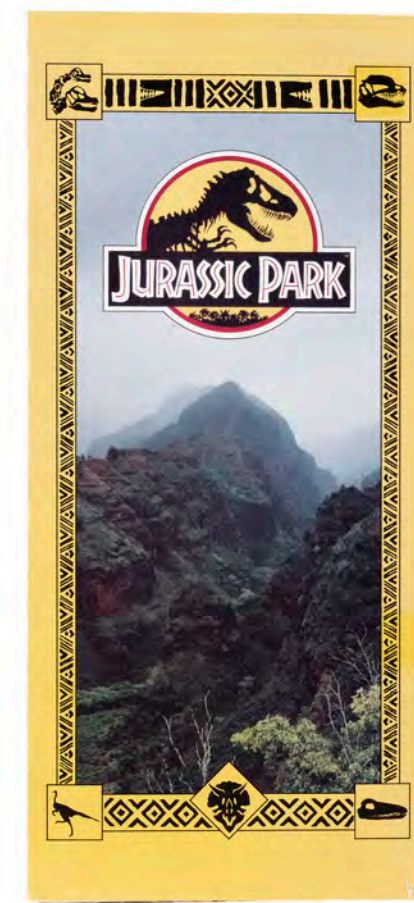

**1402**  
 Park Visitor Brochure Ω  
**Jurassic Park (1993)**

A park visitor brochure from Steven Spielberg's Jurassic Park. The park's brochures appeared at various locations throughout the film, including the Visitor Center and within the Ford Explorer tour vehicles. Jurassic Park won a total of three Academy Awards® for Best Sound Effects Editing awarded to Gary Rydstrom and Richard Hymns, Best Sound to Gary Summers, Gary Rydstrom, Shawn Murphy and Ron Judkins, and Best Visual Effects to Dennis Muren, Stan Winston, Phil Tippett and Michael Lantieri. The film also won three Saturn Awards to Steven Spielberg for Best Director, Best Science Fiction Film, and Best Special Effects to Dennis Muren, Stan Winston, Phil Tippett, and Michael Lantieri. This double-sided, glossy paper brochure features a printed map of Jurassic Park on one side, pinpointing different sites on the island including the Visitor Center, helipad, dinosaur enclosures, and electric fences. The reverse shows a printed drawing of the park gates with general information, including a section in Japanese, a camera film advertisement, and a mountain terrain photograph that forms the front cover. The brochure exhibits creasing, some fading, and minor warping from age. Dimensions: (folded) 21 cm x 9.5 cm x 0.75 cm (8.25" x 4" x 0.25")

**Estimate: £1,500 - 3,000**



**1403**  
 Distressed Walkie-Talkie Ω  
**Jurassic Park (1993)**

A distressed walkie-talkie from Steven Spielberg's Jurassic Park. Dr. Ellie Sattler (Laura Dern) grabbed two walkie-talkies before attempting to restore the power in Jurassic Park. In a deleted scene, she was grabbed by the escaped velociraptors, damaging a walkie-talkie. Built to resemble a Motorola Saber UHF, this static styrene and resin styrene and resin walkie-talkie is painted grey and black with nonfunctional computer chips on the interior. It is intentionally distressed by production with broken panelling and various cracks and scratches to appear damaged. Following production, the walkie-talkie underwent sympathetic restoration to return it to its original 1993-era look. It exhibits some missing broken pieces and an exposed interior. Dimensions: (largest) 16.5 cm x 7.75 cm x 3.25 cm (6.5" x 3" x 1.25") Contains electronics; see electronics notice in the Buyer's Guide.

**Estimate: £1,200 - 2,400**



**1404**  
 Amanda Kirby's (Téa Leoni) Costume and Blouse M  
**Jurassic Park III (2001)**

Amanda Kirby's (Tea Leoni) costume and blouse from Joe Johnston's sci-fi horror sequel Jurassic Park III. Amanda wore her costume as she searched for her son on Isla Sorna with Dr. Alan Grant (Sam Neill) and others. The costume consists of a pink Anto shirt (labelled "TL Aug 2000"); a white cotton tank top ("Stunts"); and a pair of khaki trousers. The costume is accompanied by a yellow Anto shirt ("Stunt" and "TL Aug 2000"), which Amanda wore when they first landed on the island, before swapping to the pink shirt. The costume has been intentionally distressed with dirt and stage blood.

**Estimate: £1,000 - 2,000**

**1405**  
 Dinosaur Egg M  
**Jurassic World (2015)**

A dinosaur egg from Colin Trevorrow's sci-fi adventure sequel Jurassic World. Eggs were seen in the opening scene of the film when genetically modified dinosaurs hatched inside a laboratory. The egg is made of resin. Dimensions: 10 cm x 10 cm x 14 cm (4" x 4" x 5.5")

**Estimate: £1,000 - 2,000**



**1406**  
 Alan Grant's (Sam Neill) Neckerchief M  
**Jurassic World Dominion (2022)**

Alan Grant's (Sam Neill) neckerchief from Colin Trevorrow's sci-fi adventure sequel Jurassic World Dominion. Alan had his neckerchief at the paleontological dig site where he was visited by Ellie Sattler (Laura Dern). This neckerchief is made of cotton and features elaborate tan-colour patterns printed throughout. Dimensions: 48.5 cm x 46 cm x 2 cm (19" x 18" x 0.75")

**Estimate: £1,000 - 2,000**

**1407**  
 Owen Grady's (Chris Pratt) Neckerchief M  
**Jurassic World Dominion (2022)**

Owen Grady's (Chris Pratt) neckerchief from Colin Trevorrow's sci-fi adventure sequel Jurassic World Dominion. Owen used his neckerchief as a bandage around his hand after the velociraptor Blue cut his palm. The neckerchief is accompanied by a production tag with "Hero" and "Owen Grady" handwritten in black ink. Dimensions: 48 cm x 44 cm (19" x 17.25")

**Estimate: £800 - 1,600**



**1408**  
 Owen Grady's (Chris Pratt) Stunt Rifle M  
**Jurassic World Dominion (2022)**

Owen Grady's (Chris Pratt) stunt rifle from Colin Trevorrow's sci-fi adventure sequel Jurassic World Dominion. Owen carried his rifle while wrangling a Parasaurolophus in the Nevada mountains and later grabbed the weapon when he and Claire (Bryce Dallas Howard) prepared to rescue Maisie (Isabella Sermon). This foam rubber Marlin Model 1895 SBL rifle is hand-painted to replicate stainless steel and wood. It features a faux scope and a static trigger while an armature runs through the centre to maintain its shape. Dimensions: 93 cm x 26.5 cm x 5.5 cm (36.5" x 10.5" x 2.25") Restricted ownership; see replica firearm notice in the Buyer's Guide.

**Estimate: £2,000 - 4,000**



**1409**  
 Rainn Delacourt's (Scott Haze) Stunt Chiappa Rhino 60DS Pistol M  
**Jurassic World Dominion (2022)**

Rainn Delacourt's (Scott Haze) stunt Chiappa Rhino 60DS pistol from Colin Trevorrow's sci-fi action sequel Jurassic World Dominion. Delacourt used his gun in Malta as dinosaurs were let loose to cause havoc. The Rhino is foam rubber painted to look like metal and has an armature running through it to maintain shape. Dimensions: 26 cm x 13.5 cm x 4.75 cm (10.25" x 5.25" x 1.75") Restricted ownership; see replica firearm notice in the Buyer's Guide.

**Estimate: £300 - 600**



**1410**  
Set of Eight Hand-Drawn Concept Sketches m  
**The Keep (1983)**

Eight hand-drawn concept sketches from Michael Mann's supernatural horror film *The Keep*. The sketches are all composed in pencil, and each depict scenes and character concepts, with additional handwritten annotations describing the image. The sketches include drawings of Molasar, the attempted rape of Eva (Alberta Watson) and Ian Mckellen as Doctor Cuzar. Two of the sketches are initialled by an "M.P.", though nobody with those initials was credited in the production of the film. The paper has become slightly warped during its time in storage, but the sketches are unaffected and overall remain in very good condition. Dimensions: 59.5 cm x 42 cm (23.5" x 16.5") Sold without copyright; see copyright notice in the Buyer's Guide.

**Estimate: £600 - 1,200**

**1413**  
Stop-motion Stegosaurus Scute n  
**King Kong (1933)**

A scute from a stop-motion stegosaurus from Merian C. Cooper's and Ernest B. Schoedsack's *King Kong*. Deep in the island jungle, Jack Driscoll (Bruce Cabot) and his men were charged by a stegosaurus with a spiked tail and scutes along its spine. Designed for the film by model maker Marcel Delgado, who developed the skeletal armatures that would revolutionise stop-motion animation, this scute is a fin-shaped plate made out of wood with a brown painted finish with dark striping as well as a buildup of black and red material on the base where it would have previously attached to the stop-motion puppet. A small question mark is hand-written on the base. It exhibits wear from use and age, including chipping throughout the finish. Dimensions: 8.5 cm x 7.75 cm x 1.5 cm (3.25" x 3" x 0.5")

**Estimate: £2,000 - 4,000**



**1414**  
Grigori Rasputin's (Rhys Ifans) Hero and Stunt Daggers and Orlando Oxford's (Ralph Fiennes) Stunt Flare Pistol tΔ  
**The King's Man (2021)**

Grigori Rasputin's (Rhys Ifans) hero and stunt daggers and Orlando Oxford's (Ralph Fiennes) stunt flare pistol from Matthew Vaughn's spy action film *The King's Man*. Rasputin used his dagger in a fight against Shola (Djimon Housou) after attempting to drown Orlando Oxford (Ralph Fiennes). Orlando used his flare pistol during the final fight of the film, firing it at Morton (Matthew Goode). The hero dagger is made of steel and retains its original production tag, which reads "Kingsman Rasputin Hero dagger", and the pistol and stunt dagger are both made of solid resin, painted to look like metal. The stunt items exhibit minor paint wear. Dimensions (Rasputin dagger): 42 cm x 9 cm x 2 cm (16.5" x 3.5" x 1")

**Estimate: £1,500 - 3,000**



**1411**  
Kick-Ass' (Aaron Taylor-Johnson) Stunt Batons m  
**Kick-Ass 2 (2013)**

A pair of Kick-Ass' (Aaron Taylor Johnson) stunt batons from Jeff Wadlow's superhero sequel *Kick-Ass*. Kick-Ass used his batons as his main weapons throughout the film as he fought against The Motherf\*\*\*\*r (Christopher Mintz-Plasse). The batons are made of foam with a solid armature and are wrapped in green faux leather. Dimensions (each): 56 cm x 4 cm x 4 cm (22" x 1.5" x 1.5")

**Estimate: £1,500 - 3,000**

**1412**  
Stunt Excalibur Sword m  
**King Arthur (2004)**

A stunt Excalibur sword from Antoine Fuqua's historical adventure film *King Arthur*. King Arthur (Clive Owen) carried Excalibur with him throughout the film, most notably during his fight with Cerdic (Stellan Skarsgård), the Saxon leader, from which he emerges the victor and after which he is proclaimed king of the Britons. Made of metal and resin, the sword features an ornate grip covered in Celtic designs, with notches and grooves engraved into the metal blade. The grip is finished in faux-bronze paint. Well-used during the production, the sword displays moderate wear to the paint finish on the grip, with scratches, notches and damage to the aluminium blade indicating the practical use of the sword in the film's fight sequences. Dimensions: 112 cm x 13 cm x 3 cm (44" x 5.25" x 1.25")

**Estimate: £2,000 - 4,000**



**1415**  
The Shepherd's (Matthew Goode) SFX and Hero Gunswords and Scabbard tΔ  
**The King's Man (2021)**

The Shepherd's (Matthew Goode) SFX and hero gunswords and scabbard from Matthew Vaughn's action spy film *The King's Man*. The Shepherd used his sword with a gun barrel hidden in the hilt during the climactic showdown with Orlando Oxford (Ralph Fiennes) and Shola (Djimon Hounsou). The hero sword's blade and gun barrel are made of aluminium, while its hilt is bronze with a wooden grip. It is accompanied by a leather scabbard which has been altered to fit the gun barrel. The SFX sword is made of hard rubber and is hand painted. The blade tip has been removed and orange tape is placed on the end as reference for the visual effects team. The SFX blade has some spotting and wear to the paintwork, and the hero blade has some sticky residue on the hilt. Dimensions (hero sword): 94 cm x 15.5 cm x 9.5 cm (37" x 6" x 3.75")

**Estimate: £1,000 - 2,000**





**1416**  
Orlando's (Ralph Fiennes) Stunt Flare Pistol,  
Conrad's (Harris Dickinson) Rasputin-Fight Pistol,  
The Sheppard's (Matthew Goode) Stunt Luger †Δ  
**The King's Man (2021)**

Three main character stunt guns from Matthew Vaughn's action-adventure film The King's Man. Orlando (Ralph Fiennes) fought with his Austrian Steyr M1912 pistol featuring an under-barrel flare launcher attachment during the climax. His opponent, The Sheppard (Matthew Goode), defended himself during the same sequence with a Luger LP08 "Artillery" fitted with a TM 08 drum magazine. While in Russia, Conrad Oxford (Harris Dickinson) fought with a Webley & Scott Metropolitan Police Model pistol. Orlando and Conrad's guns are rubber, while The Sheppard's is made of resin. The Sheppard's Luger exhibits looseness at the point where the handle is connected to the additional drum magazine. Dimensions: (Luger) 33 cm x 10 cm x 24.5 cm (13" x 4" x 9.75") Restricted ownership; see replica firearm notice in the Buyer's Guide.

**Estimate: £500 - 1,000**



**1417**  
Whiskey's (Pedro Pascal) Stunt Revolvers  
and Shoulder Holsters †Δ  
**Kingsman: The Golden Circle (2017)**

Whiskey's (Pedro Pascal) revolvers and holster from Matthew Vaughn's action comedy Kingsman: The Golden Circle. Whiskey wore his holster and used his revolvers during an ambush by the Golden Circle's henchmen, when he was shot by Harry (Colin Firth) and revived by Eggsy (Taron Egerton). The holster belt is made of suede and leather and features a pyrographed "S" detail on each holster pouch. The pistols are made of wood and resin, and are painted to look silver, with a black floral pattern. One of the pistols exhibits significant paint flaking, and the other exhibits minor flaking. Dimensions: 37 cm x 23 cm x 10 cm (14.5" x 9" x 4") Restricted ownership; see replica firearm notice in the Buyer's Guide.

**Estimate: £800 - 1,600**



**1418**  
King Baldwin's (Edward Norton) Ring  
and Prototype Mask m  
**Kingdom Of Heaven (2005)**

King Baldwin's (Edward Norton) ring and prototype mask from Ridley Scott's historical epic Kingdom of Heaven. King Baldwin wore a mask to hide his disfigurement from leprosy and made Raynald of Chatillon (Brendan Gleeson) kiss his ring before whipping him. The mask is made of fibreglass and is painted to look like silver. It features leather padding on the interior and an elasticated headband. The ring is aluminium with a faux gem and the centre. The shank has been altered and is attached to elastic, allowing it to fit over the prosthetic hands Norton wore. Dimensions (mask): 12.5 cm x 15 cm x 22.5 cm (5" x 6" x 8.75")

**Estimate: £1,000 - 2,000**



**1419**  
Ishmael Boorg's (Randy Quaid)  
Costume Ω  
**Kingpin (1996)**

Ishmael Boorg's (Randy Quaid) costume from Bobby and Peter Farrelly's Kingpin. Ishmael wore his costume when he agreed to be a dancer for Stiffy's Exotic Dancing and Spirits when he was unable to pay for a lap dance. Quaid wore the robe in a deleted section of the scene and was seen wearing it in a behind-the-scenes photo. This lot consists of a light blue polyester mesh robe with navy blue sequin beading throughout and a light blue feathered trim. This lot exhibits minor discoloration and missing feathers from the left bottom.

**Estimate: £1,500 - 3,000**



**1420**  
Ishmael Borg's (Randy Quaid)  
Amish Costume Ω  
**Kingpin (1996)**

Ishmael Borg's (Randy Quaid) Amish costume from Bobby and Peter Farrelly's Kingpin. Amish bowler Borg wore his costume when he met Roy Munson (Woody Harrelson) at the Lancaster Bowl, and later when he agreed to be Munson's client and compete in the Reno Open Bowling Tournament. This costume consists of a light blue cotton Anto button-down, long-sleeve shirt labelled "RQ Sept 1995"; a black cotton denim jacket; and a pair of black cotton denim Levi trousers. This lot exhibits minor discoloration and thinning fabric from age and wear.

**Estimate: £1,200 - 2,400**



**1421**  
Keith Hamshere Collection:  
Set of Production and  
Promotional Photographs m  
**Krull (1983)**

A collection of silver gelatin production and promotional photographs from Peter Yates' fantasy adventure Krull. This lot comes from the personal collection of renowned stills photographer Keith Hamshere. This lot comprises 53 large black-and-white silver gelatin and three colour photographs. They are a mixture of behind-the-scenes, stills and promotional photography, featuring the stars Ken Marshall (Colwyn), Lysette Anthony (Lyssa) and Freddie Jones (Ynyr). Most of the photographs feature handwritten numbers on the reverse. Dimensions (each b/w image): 40.5 cm x 30.5 cm (16" x 12") Sold without copyright; see copyright notice in the Buyer's Guide.

**Estimate: £2,000 - 4,000**



**1422**  
**Prince Colwyn's (Ken Marshall) Tunic m**  
**Krull (1983)**

Prince Colwyn's (Ken Marshall) tunic from Peter Yates' sci-fi fantasy film Krull. Prince Colwyn wore his tunic for the first half of the film, beginning at his and Princess Lyssa's (Lysette Anthony) wedding. The tunic is made of suede and leather and fastens at the front with a hook and eye fastening. The tunic has some minor staining, most notably on the front left.

**Estimate: £3,000 - 6,000**

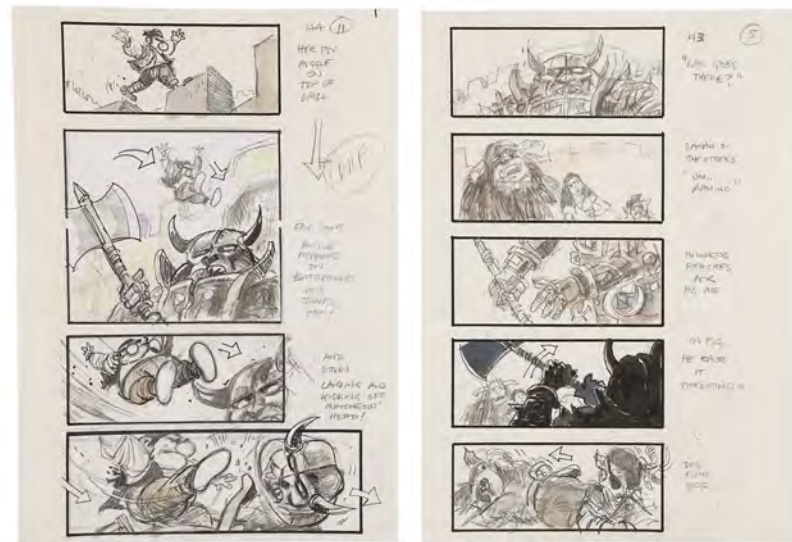

**1423**  
**Pair of Martin Asbury Hand-drawn Storyboard Pages m**  
**Labyrinth (1986)**

A pair of Martin Asbury hand-drawn storyboard pages from the production of Jim Henson's fantasy film Labyrinth. These two pages feature hand-drawn illustrations within frames, depicting parts of a scene where Hoggle (Brian Henson) saves Sarah (Jennifer Connelly) and her friends from Humongous. The illustrations are rendered in pencil and ink and accompanied by handwritten descriptions, notes on camera angles and directional arrows. Dimensions: 30 cm x 21.5 cm (11.75" x 8.5") Sold without copyright; see copyright notice in the Buyer's Guide.

**Estimate: £2,000 - 4,000**

**1424**  
**Set of Four Hand-drawn Martin Asbury Storyboard Pages m**  
**Labyrinth (1986)**

A set of four storyboard pages hand-drawn by Martin Asbury for the production of Jim Henson's fantasy film Labyrinth. These four pages feature hand-drawn illustrations within frames, depicting various scenes, including Hoggle's (Brian Henson) and Sarah's (Jennifer Connelly) encounter with a fairy, their dangerous trek across a ledge, and a baby falling off a staircase. The illustrations are rendered in pencil and ink and accompanied by handwritten descriptions, notes on camera angles and directional arrows. Dimensions: 30 cm x 21.5 cm (11.75" x 8.5") Sold without copyright; see copyright notice in the Buyer's Guide.

**Estimate: £2,500 - 5,000**



**1425**  
**Pair of Martin Asbury Hand-drawn Storyboard Pages m**  
**Labyrinth (1986)**

A pair of Martin Asbury hand-drawn storyboard pages from the production of Jim Henson's fantasy film Labyrinth. These two pages feature hand-drawn illustrations within frames. The first depicts Hoggle (Brian Henson) hijacking a mad scientist's machine, while the second shows him falling to Sarah (Jennifer Connelly). The illustrations are rendered in pencil and ink and accompanied by handwritten descriptions, notes on camera angles and directional arrows. Dimensions: 30 cm x 21.5 cm (11.75" x 8.5") Sold without copyright; see copyright notice in the Buyer's Guide.

**Estimate: £2,000 - 4,000**



**1426**  
**Goblin Helmet m**  
**Labyrinth (1986)**

A goblin helmet from Jim Henson's fantasy adventure Labyrinth. Servants in the army of Goblin King Jareth (David Bowie) wore their armour as they attempted to prevent Sarah (Jennifer Connelly) from reclaiming her baby brother. The helmet is made of resin, with an inner lining comprising a metal frame and a plastic construction helmet that allowed the actor to wear the helmet. It also features a pair of upward-facing horn accents on the sides and an asymmetrical cone-like detail protruding from the front. Dimensions: 35 cm x 42 cm x 37.5 cm (13.75" x 16.5" x 14.75")

**Estimate: £1,000 - 2,000**



**1427**  
**Miss Shepherd's (Maggie Smith) Screen-matched Costumes +**  
**The Lady In The Van (2015)**

Miss Shepherd's (Maggie Smith) screen-matched costumes from Nicholas Hytner's comedy The Lady in the Van. Miss Shepherd wore her costumes throughout the film, most notably her raincoat, which she wore while painting her van yellow. This lot comprises a clear raincoat, two cardigans (one light blue, one grey), two dresses (one dark brown, one beige), a brown jacket, a patterned scarf, a bag, a black hat and a pair of brown boots. Production-made tears in the fabric match the jacket and light blue cardigan to those seen in the film. The raincoat is heavily splattered with yellow paint from production, and most of the other items feature deliberate production-added damage, such as tears and holes, as well as production-added dirt. The beige dress features a label which reads "20th Century Props".

**Estimate: £1,000 - 2,000**

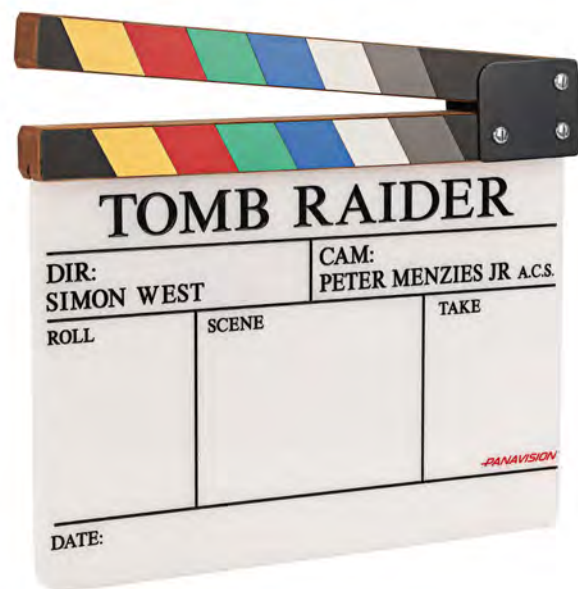

**1428**  
Clapperboard M  
**Lara Croft: Tomb Raider (2001)**

A clapperboard from the production of Simon West's action-adventure film Lara Croft: Tomb Raider. The clapperboard has an acrylic slate, on which are engraved the film's title and the names of the director and camera operator Peter Menzies Jr. The boxes on the slate's middle section are engraved with the headings "Roll", "Scene" and "Take". Engraved into the bottom of the slate are a "Date" section and the Panavision logo. The clapperboard's sticks are made of wood, and painted in bright colours. Dimensions: 23.5 cm x 28 cm x 3 cm (9.5" x 11" x 1")

**Estimate: £1,000 - 2,000**

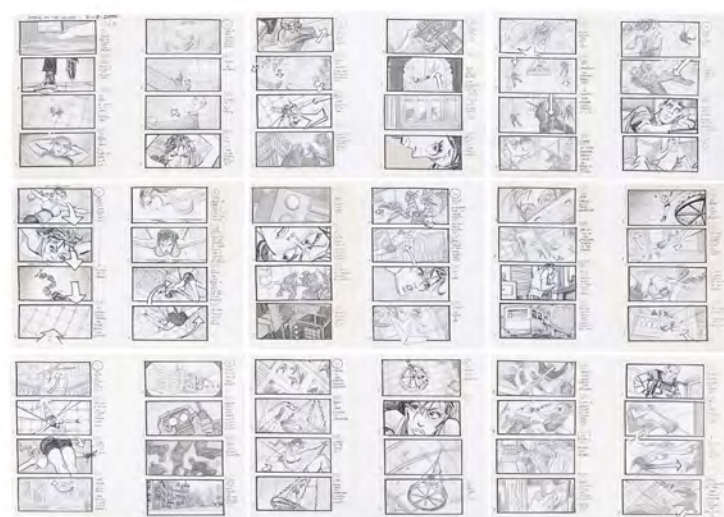

**1429**  
Collection of Martin Asbury Hand-drawn  
Production Storyboards M  
**Lara Croft: Tomb Raider (2001)**

A collection of Martin Asbury hand-drawn storyboards from Simon West's action-adventure Lara Croft: Tomb Raider. Asbury has storyboarded many high-profile films such as 'Labyrinth', 'Interview with the Vampire', 'Alien 3' and two of the Harry Potter features. The lot comprises 38 pages depicting the attack on Croft's house, during which the clock is stolen. The storyboards are rendered onto paper and cardstock in pencil and ink and feature handwritten annotations. The shots differ slightly from those in the final cut. The pages exhibit some markings and minor discolouration. Dimensions: 30 cm x 21.5 cm x 2 cm (11.75" x 8.5" x 1") Sold without copyright; see copyright notice in the Buyer's Guide.

**Estimate: £1,500 - 3,000**



**1430**  
Collection of Martin Asbury Hand-Drawn  
Production Storyboards M  
**Lara Croft: Tomb Raider (2001)**

A collection of Martin Asbury hand-drawn storyboards from Simon West's action-adventure Lara Croft: Tomb Raider. Asbury has storyboarded many high-profile films such as 'Labyrinth', 'Interview with the Vampire', 'Alien 3' and two of the Harry Potter features. This collection features 68 pages of hand-drawn storyboards from the opening scene of the film, in which Lara Croft fights a robot. The storyboards are rendered onto paper and cardstock in pencil and ink and feature handwritten annotations. The shots differ slightly from those in the final cut. The pages exhibit some markings and minor discolouration. Dimensions: 30 cm x 21.5 cm x 2 cm (11.75" x 8.5" x 1") Sold without copyright; see copyright notice in the Buyer's Guide.

**Estimate: £1,500 - 3,000**



**1431**  
Lara Croft's (Angelina Jolie) Heckler & Koch P11  
Underwater Pistol ΔΔ  
**Lara Croft: Tomb Raider - The Cradle Of Life (2003)**

Lara Croft's (Angelina Jolie) Heckler & Koch P11 underwater pistol from Jan de Bont's Lara Croft: Tomb Raider - The Cradle of Life. Croft wielded her H&K P11 in the opening sequence where she narrowly escaped Chen Lo's (Simon Yam) attack on the Luna Temple. This static resin pistol features five barrels hand-painted matte grey to appear metallic, a textured black handgrip and twin sights, and an immovable safety switch painted red. Paint is flaking throughout, exposing the resin around the top and sides, and the grip exhibits stickiness from production use and age. Dimensions: 20.5 cm x 18 cm x 5 cm (8" x 7" x 2") Ownership may be restricted in some countries; see replica firearm notice in Buyer's Guide.

**Estimate: £1,200 - 2,400**

**1432**  
Magic Movie Theatre Ticket and SFX Knife Grenade ΔΔ  
**Last Action Hero (1993)**

A magic movie theatre ticket and an SFX knife grenade from John McTiernan's action comedy Last Action Hero. Danny Madigan (Austin O'Brien) used a magic movie ticket to transport himself into his favourite film series, Jack Slater. Its hero, Jack Slater (Arnold Schwarzenegger), threw a knife grenade to a little boy, so he could free himself from the Ripper (Tom Noonan). The ticket for the "Raj Palace" is made of gold-coloured card. The grenade knife features a resin grenade with a metal pin and lever, and has a metal blade protruding out of the bottom. The blade is retractable, to give the impression of penetrating flesh. The ticket has some wear and discolouration on the reverse where it was previously held in a display. The grenade has some paint wear. Dimensions (ticket): 7.5 cm x 15.5 cm (3" x 6")

**Estimate: £2,000 - 4,000**



**1433**  
Detective Jack Slater's (Arnold Schwarzenegger) Costume Δ  
**Last Action Hero (1993)**

Detective Jack Slater's (Arnold Schwarzenegger) costume from John McTiernan's Last Action Hero. Slater wore his costume throughout the film as he investigated criminal activities and then pursued Mr. Benedict (Charles Dance) in the real world with Danny (Austin O'Brien) This lot consists of a tan faux leather jacket; a red cotton shirt; a brown leather belt; a metal belt buckle emblazoned with "Marksmanship Slater"; a pair of blue denim jeans; and a pair of faux snakeskin boots. The interior of the boots are hand-marked "Arnold Tar Pits" in black ink. This costume exhibits a hole in the red shirt as well as faded colour, scuffed boots, and discolouration on the jeans.

**Estimate: £2,000 - 4,000**



**1434**  
Dragonslayer's (Nick Mohammed)  
Suit of Armour M  
**The Last Dragonslayer (2016)**

The Dragonslayer's (Nick Mohammed) suit of armour from Jamie Magnus Stone's fantasy film *The Last Dragonslayer*. The Dragonslayer was wearing his armour when he was introduced to Jennifer Strange (Ellise Chappell), an orphaned girl on a journey to become a dragonslayer herself. The suit is made of polyurethane, painted to look like metal, and features intentional wear to contribute to a battle-worn look, including deliberate dents and blade marks in the breastplate. This lot consists of the full suit of armour, including a breastplate, pauldrons, fauld, helmet, gauntlets, vambrace, couter, rerebrace, sabatons and greaves. The visor hinge on the helmet is functional.

**Estimate: £3,000 - 6,000**



**1435**  
Jacques le Gris' (Adam Driver)  
Shield M  
**The Last Duel (2020)**

Jacques le Gris' (Adam Driver) shield from Ridley Scott's historical drama *The Last Duel*. Le Gris used his shield during his judicial duel with Jean de Carrouges (Matt Damon), after being accused of rape by Carrouges' wife, Marguerite (Jodie Comer). The shield is made of wood and covered with a layer of canvas. Painted onto the front is the le Gris heraldry: a snake and crow, painted onto a background of teal and grey. The back of the shield features two metal handles, one curved and joined to the shield only at one end, the other squared and joined at both ends. Dimensions: 65 cm x 54 cm x 15 cm (25.75" x 21.25" x 6")

**Estimate: £1,500 - 3,000**



**1436**  
Rylan Emergency Worker Costume M  
**The Last Starfighter (1984)**

A Rylan emergency worker costume from Nick Castle's *The Last Starfighter*. After the Starfighter base was attacked by the Ko-Dan, and Alex (Lance Guest) and Centauri (Robert Preston) returned from Earth, emergency workers in blue uniforms helped survivors and repaired systems. This costume consists of a blue cotton-blend jumpsuit with a white striping and a yellow and black symbol on the back, two metal collar pins, and additional silver-colour resin and wood attachments to the chest and cuffs. The hat features a hand-marked "24" tag on the interior hem and the costume features "Rodney" hand-marked on the interior. This costume exhibits minor signs of wear from age and use throughout, including some damage to one of the metal shoulder paint.

**Estimate: £800 - 1,600**



**1437**  
Tristan Ludlow's (Brad Pitt)  
World War I Costume M  
**Legends Of The Fall (1994)**

Tristan Ludlow's (Brad Pitt) World War I costume from Edward Zwick's *Legends of the Fall*. Tristan wore his costume when he joined with the Canadian Expeditionary Force in Germany to fight alongside his brothers Samuel (Henry Thomas) and Alfred (Aidan Quinn). This costume consists of an olive green button-up wool jacket with four pockets on the chest and a pair of gold-colour metal details on the epaulettes, as well as a matching pair of button-up trousers. The interior of the jacket is labelled "COLLAR 17 BRAD PITT MAY 1993." The costume exhibits minor signs of wear from age and use throughout, including some damage to one of the metal shoulder details.

**Estimate: £2,000 - 4,000**

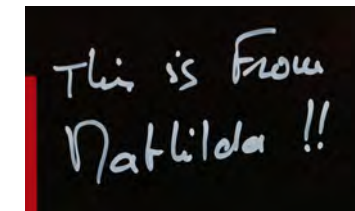

**1438**  
Jean Reno-Autographed  
Reprint One Sheet M  
**Léon: The Professional (1994)**

A reprint British One Sheet poster for Luc Besson's crime thriller *Leon*, autographed by Jean Reno. Reno, who played Leon, has signed the poster with his autograph and the character's name in silver marker to the left of the film's title. On the opposite side of the title, he has written, "This is from Mathilda," Leon's final line of dialogue in the film. Dimensions: 101 cm x 68.5 cm (39.75" x 27") The autographs in this lot have been professionally authenticated by expert Garry King; see notice in the Buyer's Guide.

**Estimate: £500 - 1,000**



**1439**  
Jean Valjean's (Hugh Jackman)  
Green Coat M  
**Les Miserables (2012)**

Jean Valjean's (Hugh Jackman) green coat from Tom Hooper's musical adaptation *Les Miserables*. Valjean wore his long green coat as he comforted a dying Fantine (Anne Hathaway) before being confronted by Javert (Russell Crowe). The coat is labelled "Sands Films", "44" and "50". Sands Films produced the costumes for the Oscar-winning film.

**Estimate: £1,500 - 3,000**



**1440**  
Monsieur Thenardier's (Sacha Baron Cohen) Wedding Costume +  
**Les Miserables (2012)**

Monsieur Thenardier's (Sacha Baron Cohen) wedding costume from Tom Hooper's musical adaptation *Les Miserables*. Monsieur Thenardier wore his flamboyant costume as he and Madame Thenardier (Helena Bonham Carter) infiltrated Cosette (Amanda Seyfried) and Marius' (Eddie Redmayne) wedding. The costume comprises a long jacket (labelled "CH 42"); a waistcoat ("CH 44"); and a pair of trousers ("36"). All the items feature "Sands Films" labels, the company that produced costumes for the Oscar-winning film. The costume pieces have been intentionally distressed with staining and wear.

**Estimate: £1,000 - 2,000**

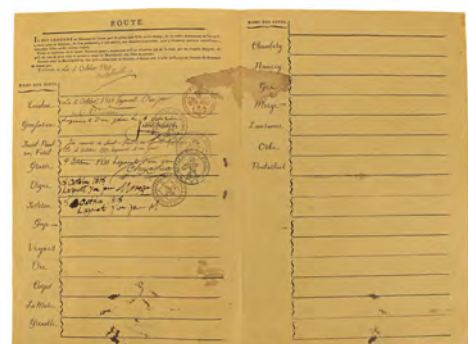
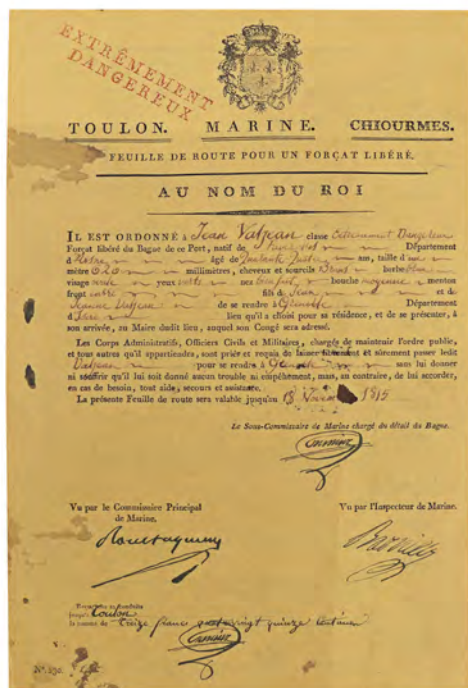

**1441**  
Jean Valjean's (Hugh Jackman) Travel Papers +  
**Les Miserables (2012)**

Jean Valjean's (Hugh Jackman) travel papers from Tom Hooper's musical adaptation *Les Miserables*. At the beginning of the film, Valjean, who had been released from prison, had to show his papers while looking for work. He tore them up when he changed his name and started a new life. The document features printed text in French, including a printed stamp which describes Valjean as "extremement dangereux". The stains and ink blots are also printed, giving the document a worn, well-handled look. It has been folded into quarters. Dimensions (open): 35.5 cm x 24 cm (14" x 9.5")

**Estimate: £1,500 - 3,000**



**1442**  
Javert's (Russell Crowe) Inspector Uniform +  
**Les Miserables (2012)**

Javert's (Russell Crowe) inspector costume from Tom Hooper's Academy Award-winning musical drama *Les Miserables*. Javert wore his inspector uniform while witnessing the strength of Jean Valjean (Hugh Jackman), and suspecting him to be a parole-violating ex-prisoner. The costume comprises a long double-breasted wax coat; a pair of beige suede trousers with white braces and lycra stirrups; a blue woollen waistcoat; and a pair of black leather gloves. The waistcoat and trousers feature labels with the word "double" written in black and the gloves have "cosprop" written on the inside. The costume displays signs of wear, including stains and marks, and the trousers are split at the front seam beneath the zip.

**Estimate: £3,000 - 6,000**

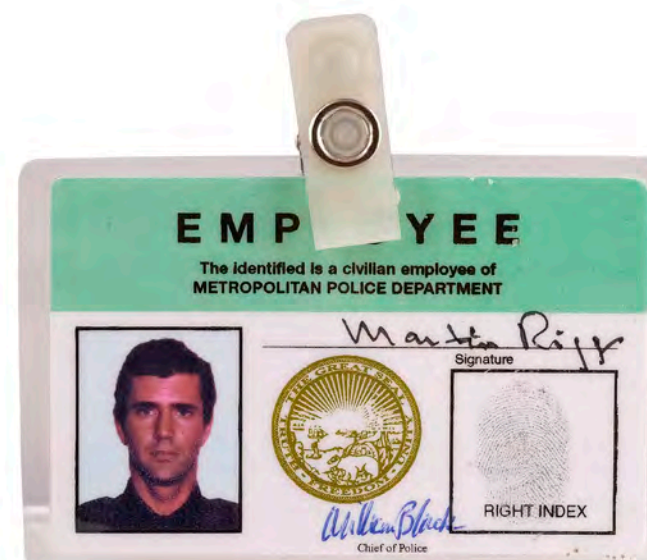

**1443**  
Production-Made Martin Riggs (Mel Gibson) Metropolitan Police ID +  
**Lethal Weapon (1987)**

A Martin Riggs (Mel Gibson) Metropolitan Police ID from the production of Richard Donner's *Lethal Weapon*. Officers and employees of the Los Angeles Police Department wore ID badges while in the offices of the department. Riggs' ID was ultimately unseen in the final cut. This lot consists of a laminated Metropolitan Police civilian employee ID badge with Riggs' name, thumb print, signature, serial number, and blood type and a small plastic and metal clip. It exhibits a mild buildup of grime on the bottom edge and small tearing of the upper edge border. Dimensions: 7.75 cm x 10.25 cm x 1.5 cm (3" x 4" x 0.5")

**Estimate: £1,000 - 2,000**



**1444**  
The Costumi d'Arte Collection: Guido's (Roberto Benigni) Screen-matched Costume +  
**Life Is Beautiful (1997)**

Guido's (Roberto Benigni) screen-matched costume from Roberto Benigni's historical comedy *Life is Beautiful*. Guido wore his suit when he arrived in Arezzo and met Dora (Nicoletta Braschi), who would become his wife. The film won three Academy Awards, including Best Foreign Language Film and Best Actor for Benigni – the first time this was won for non-English performance. This lot comes from the archives of the Italian costume company Costumi d'Arte. The costume comprises a plaid jacket, a tan waistcoat and a tan pair of trousers. The jacket screen matches via its plaid detailing, particularly around the collar. Each piece is marked size "48" and has a handwritten label that reads "V.B. 012 R. Benigni".

**Estimate: £1,000 - 2,000**

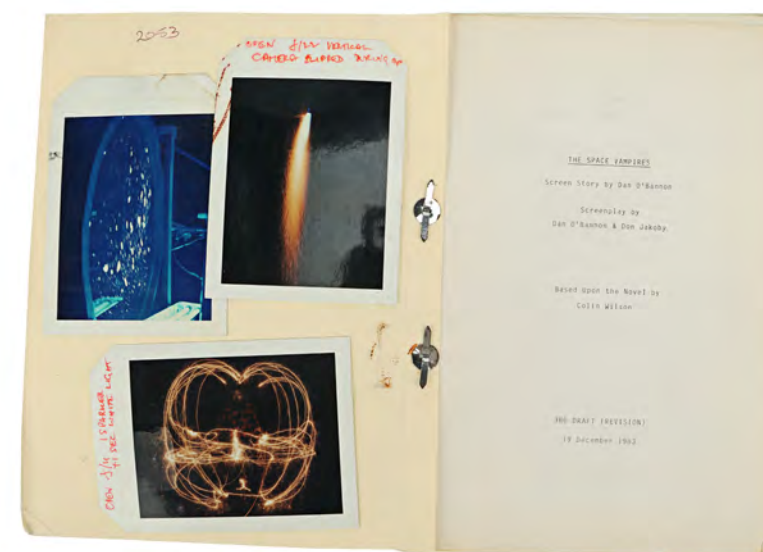

**1445**  
John Dykstra's Personal Shooting Script and Photos +  
**Lifeforce (1985)**

Special visual effects artist John Dykstra's personal shooting script and photos from the production of Tobe Hooper's sci-fi horror film *Lifeforce*. This is the third-draft script, and features the film's working title, "The Space Vampires". The script is dated "19 December 1983" and credited to Dan O'Bannon and Don Jakoby. "Master Script M/O Unit" is handwritten on the front cover, with "J. Dykstra" written on the second page. The script's pages are printed on differently coloured paper, indicating multiple revisions. On the inside of the front cover are three pictures of lighting effects tests for the film. The script is 133 pages long and bound between card covers decorated with the London Cannon Films Limited logo. Dimensions: 30 cm x 22 cm x 2 cm (12" x 9" x 1")

**Estimate: £500 - 1,000**



**1446**  
 Art Department Sign m  
**Little Shop Of Horrors (1986)**

An art department sign from the production of Frank Oz's comedy-musical Little Shop of Horrors. The wooden sign features a handpainted version of the film's title artwork. This sign would have been hung by the art department's area on set. The sign is accompanied by a letter of authenticity from Warner Bros. Productions. Dimensions: 61 cm x 46 cm x 0.75 cm (24" x 18" x 0.25")

**Estimate: £400 - 800**



**1447**  
 Jo March's (Saoirse Ronan) Skating Costume m  
**Little Women (2019)**

Jo March's (Saoirse Ronan) skating costume from Greta Gerwig's literary adaptation Little Women. Jo wore her costume at several points in the film, most notably when she went ice skating with Laurie (Timothee Chalamet) and her sister Amy (Florence Pugh) fell through the ice. The costume consists of a check blouse (labelled "Jo"); a woollen skirt ("Jo - Ice Skate 1"); a short jacket; and a red woollen cape. All the items bar the cape feature "Sands Films" labels, the company that produced costumes for the Oscar-winning film.

**Estimate: £1,000 - 2,000**

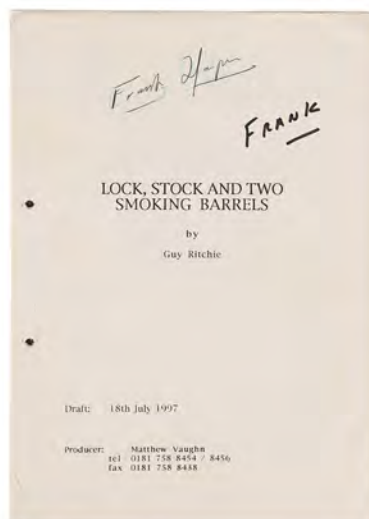

**1448**  
 Frank Harper Collection: Production-Used and Autographed Script, Autographed Call Sheet and Screening Tickets m  
**Lock, Stock And Two Smoking Barrels (1998)**

A Frank Harper autographed production-used script, autographed call sheet, and two screening tickets from the production of Guy Ritchie's indie crime-drama Lock, Stock and Two Smoking Barrels. Ritchie's feature debut immediately showcased his unique style of quirky characters, witty rhyming slang dialogue, and comedically nihilistic violence. Frank Harper, who played Dog in the film, has autographed the script and the call sheet on their front pages. The call sheet includes scheduled times for prominent cast members, including Jason Statham. Dimensions (script): 29.75 cm x 21.25 cm x 1 cm (11.75" x 8.25" x 0.5") The autographs in this lot have been professionally authenticated by expert Garry King; see notice in the Buyer's Guide.

**Estimate: £2,000 - 4,000**



**1449**  
 Snow's (Guy Pearce) Screen-matched Light-up Spacesuit Helmet and Portable Life Support System m  
**Lockout (2012)**

Snow's (Guy Pearce) screen-matched, light-up spacesuit helmet and portable life support system from James Mather and Steve Saint Leger's Lockout. Snow wore his spacesuit when he infiltrated maximum security space penitentiary MS One. Unique nicks on the front of the chin and forehead of the helmet, as well as unique stitching and folds found on the corner of the life support pack, screen-match to shots of Snow wearing the suit. This lot consists of a white fibreglass helmet with foam padding, a built-in fan, and a dark acrylic visor wired with lights along its edges, as well as a white canvas backpack-like accessory representing a portable life support system (PLSS) labelled "L.O.P.D." with a NASA logo patch, grey nylon harness straps with plastic and metal buckles, and embedded resin and metal embellishments with fine print labelling and inset battery-powered red lights. Following production, the helmet underwent sympathetic repair to reconnect its visor and lighting elements. The PLSS exhibits some discolouration and staining. Contains electronics; see electronics notice in the Buyer's Guide.

**Estimate: £2,000 - 4,000**

**1450**  
 Positive's "Half Life" Stun Pistol m  
**Logan's Run - Half Life (1977)**

A Positive's stun pistol from the classic Season 1 episode "Half Life" of the television series Logan's Run. In the episode, Positives wielded distinctive pistols and saved Logan 5 (Gregory Harrison), Jessica 6 (Heather Menzies), and Rem (Donald Moffatt) from a group of people known as Negatives made from the Positives' own split personalities. This futuristic pistol with static keyholes on its sides is cast from resin, etched with inventory number "8089N MGM" for MGM Television - the series' production company - on the underside, and hand-painted black on the grip and butt and silver-colour on the barrel and side details. It exhibits a broken muzzle tip, extensive scratching, and discolouration throughout to its finish from production use and age. Dimensions: 35.75 cm x 14 cm x 5.75 cm (14" x 5.5" x 2.25")

**Estimate: £1,000 - 2,000**



**1451**  
 Pair of Uruk-Hai Prosthetic Ears m  
**The Lord Of The Rings: The Fellowship Of The Ring (2001)**

A pair of uruk-hai ears from Peter Jackson's fantasy film The Lord of the Rings: The Fellowship of the Rings. The ears come mounted in a custom display, and are presented alongside a photo of Lurtz, the first of the uruk-hai to be bred by Saruman, autographed by the actor that played him, Lawrence Makoare. The ears are made of foam latex, and over time have begun to exhibit some shrinkage and discolouration, but otherwise remain in very good condition. Dimensions: 66 cm x 48 cm x 3 cm (26" x 19" x 1.25")

**Estimate: £1,000 - 2,000**



**1452**  
Peregrine Took's (Billy Boyd) Prosthetic Hobbit Ears †Δ  
**The Lord Of The Rings: The Fellowship Of The Ring (2001)**

Pippin Took's (Billy Boyd) prosthetic hobbit ears from Peter Jackson's epic fantasy film *The Lord of the Rings: The Fellowship of the Ring*. All the hobbit ears that appear in the trilogy were custom-made by Weta Workshop to securely fit each performer. These large silicone ears are hand-painted pink and peach to resemble skin, and come mounted to two plaster bases engraved "B.B.". The slightly adhesive nature of the silicone means that both ears have attracted lint. Dimensions (one ear): 14.5 cm x 10 cm x 2 cm (6" x 4" x 1")

**Estimate: £1,000 - 2,000**



**1453**  
Old Bilbo Baggins' (Ian Holm) Silicone Hobbit Ears †Δ  
**The Lord Of The Rings: The Fellowship Of The Ring (2001)**

Old Bilbo Baggins' (Ian Holm) silicone hobbit ears from Peter Jackson's epic fantasy film *The Lord of the Rings: The Fellowship of the Ring*. All the hobbit ears that appear in the trilogy were custom-made by Weta Workshop to securely fit each performer. These large silicone ears are hand-painted pink and peach to resemble skin. The slightly adhesive nature of the silicone means that both ears have attracted lint. Dimensions (one ear): 12 cm x 9 cm x 2 cm (5" x 3.5" x 1")

**Estimate: £1,500 - 3,000**

**1454**  
Orc Sword Ω  
**The Lord Of The Rings: The Fellowship Of The Ring (2001)**

An orc sword from Peter Jackson's fantasy epic *The Lord of the Rings: The Fellowship of the Ring*. The orcs who made up most of Sauron's forces wielded their crude but deadly weapons, such as swords, throughout the War of the Ring. This sword is made of resin, painted grey and black with production-applied distressing to make it look old and worn, and it features pointed tips and a black woven tape-wrapped handle. It exhibits wear from use and age, including scuffs, cracks and warping. Dimensions: 91 cm x 17 cm x 3 cm (36" x 6.75" x 1.25")

**Estimate: £3,000 - 6,000**

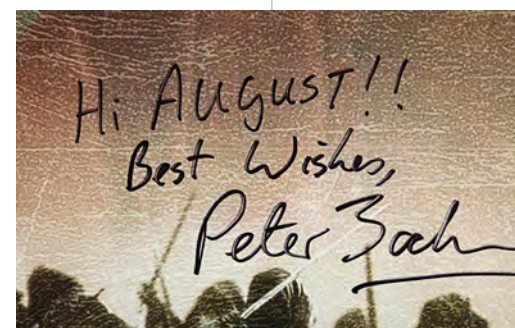

**1455**  
Elijah Wood, Viggo Mortensen, Ian McKellen and Cast-Autographed Poster †Δ  
**The Lord Of The Rings: The Fellowship Of The Ring (2001)**

A poster autographed by the cast of Peter Jackson's epic fantasy film *The Lord of the Rings: The Fellowship of the Ring*. This glossy colour poster features the main characters, and is autographed in silver, white, black, blue and gold ink by 16 members of the trilogy's cast and crew, including Viggo Mortensen (Aragorn), Elijah Wood (Frodo), and Ian McKellen (Gandalf). The edges of the poster exhibit some minor creasing, and there is a small tear along the bottom edge. The poster has been rolled for storage. Dimensions: 68 cm x 13 cm (27" x 5") The autographs in this lot have been professionally authenticated by expert Garry King; see notice in the Buyer's Guide.

**Estimate: £2,000 - 4,000**

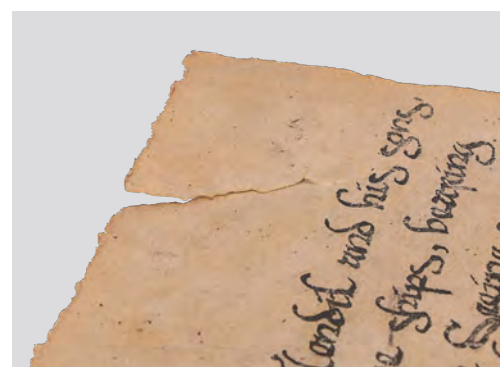
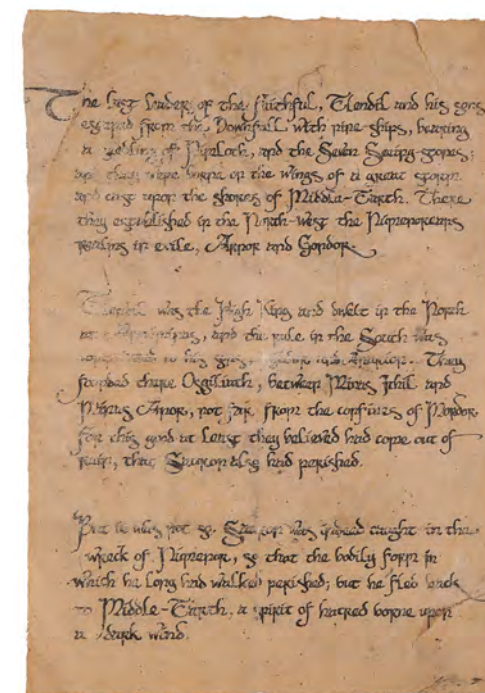

**1456**  
Page of 'Annals of the Kings and Rulers' from Bilbo's (Ian Holm) House M  
**The Lord Of The Rings: The Fellowship Of The Ring (2001)**

A page of writing taken from *The Lord of the Rings*, Appendix A, *Annals of the Kings and Rulers: Númenor*, from Bilbo's (Ian Holm) house from Peter Jackson's fantasy epic *The Lord of the Rings: The Fellowship of the Ring*. Bilbo had miscellaneous pages of writing and maps scattered about his hobbit hole. This particular page describes the escape of Elenil and his sons from the downfall of Númenor, an event which predates the events of the film. The text is printed upon one side of the page, and the other side left blank. The writing is faded in places, and the page is torn and deliberately weathered for production, but otherwise, it remains in very good condition. Dimensions: 38 cm x 25 cm (15" x 10")

**Estimate: £500 - 1,000**



**1457**  
Dharma Initiative Beer Can M  
**Lost (T.V. Series, 2004-2010)**

A Dharma Initiative beer can from sci-fi mystery series *Lost*. Workers of the Dharma Initiative ate and drank only products made by Dharma, and the islanders found various Dharma consumables around the island. The unsealed, empty can features the same plain white design as the other Dharma products with the geometric black Dharma label. The can reads "Dharma Initiative Beer" and features a barcode and Surgeon General's warning on the side. The can has some minor dents and is missing its ring pull. Dimensions: 6.5 cm x 6.5 cm x 12.5 cm (2.5" x 2.5" x 5")

**Estimate: £500 - 1,000**



**1458**  
 Cast and Writer-Autographed First Draft Pilot Script  
 "Smoke Gets In Your Eyes"  $\Omega$   
**Mad Men - Smoke Gets In Your Eyes (2007)**

A cast and writer-autographed first draft pilot script "Smoke Gets In Your Eyes" from Mad Men. In the pilot episode, Don Draper (Jon Hamm) struggled to adjust to the changing environment and elements of the advertising world. This pilot script is a Writer's First Draft script dated April 5, 2001 with 52 pages in a clear plastic portfolio cover. The cover of the script features autographs in black ink from writer Matthew Weiner, Jon Hamm, John Slattery, January Jones, Aaron Staton, Elizabeth Moss, Vincent Kartheiser, Maggie Siff, Bryan Batt, Rich Sommer, and Christina Hendricks. This script exhibits minor tears and wrinkling to the bottom of the pages. Dimensions: 23 cm x 29.25 cm x 1.5 cm (9" x 11.5" x 0.5")

**Estimate: £2,000 - 4,000**



**1459**  
 Don Draper's (Jon Hamm) Suit Jacket and Pants  $\Omega$   
**Mad Men - The Flood (2013)**

Don Draper's (Jon Hamm) suit jacket and trousers from Matthew Weiner's Mad Men. In the Season 6 episode "The Flood," Don wore one of his signature grey suits to a meeting with insurance salesman Randall Walsh (William Mapother), who claimed he was visited by the ghost of the recently-assassinated Dr. Martin Luther King, Jr. This lot consists of a grey wool Barrcrest suit jacket (Size 41) with a three-button closure, a chest pocket, two flap pockets, black satin lining, and a Palace Costume Co. barcode with inventory number "37367389" applied to the interior, as well as matching trousers with a zip-front closure, tan lining on the interior, and both legs cuffed by production with a Palace barcode numbered "37254133." The jacket and trousers exhibit some creasing, most visibly on the interior, from production wear.

**Estimate: £1,200 - 2,400**



**1460**  
 Frank T.J. Mackey's (Tom Cruise) Watch  $\Omega$   
**Magnolia (1999)**

Frank T.J. Mackey's (Tom Cruise) watch from Paul Thomas Anderson's drama Magnolia. Frank, a motivational speaker and pick-up artist, wears his watch throughout the film. Cruise was nominated for "Best Supporting Actor" for his performance, and won the award in that category at the 2000 Golden Globes. The watch is a Timex® Expedition Indiglo WR-30M compass watch with a custom leather strap. Dimensions: 23.5 cm x 6 cm x 1 cm (9.25" x 2.5" x 0.5") Contains mechanical components; see mechanical notice in the Buyer's Guide.

**Estimate: £2,000 - 4,000**

**1461**  
 Luke Trimble's (Matt Damon) Headstone  $\Omega$   
**The Majestic (2001)**

Luke Trimble's (Matt Damon) headstone from Frank Darabont's The Majestic. Harry Trimble took Peter Appleton (Jim Carrey) to the town's cemetery to show him the tombstones of the young men the town lost during World War II, including Harry's son Luke who he believed was Peter. This lot consists of a wooden and plaster-coated headstone painted grey to resemble marble and embossed with Luke's memorial details. The headstone exhibits grime residue. Dimensions: 33 cm x 66 cm x 9 cm (13" x 26" x 3.5")

**Estimate: £1,000 - 2,000**

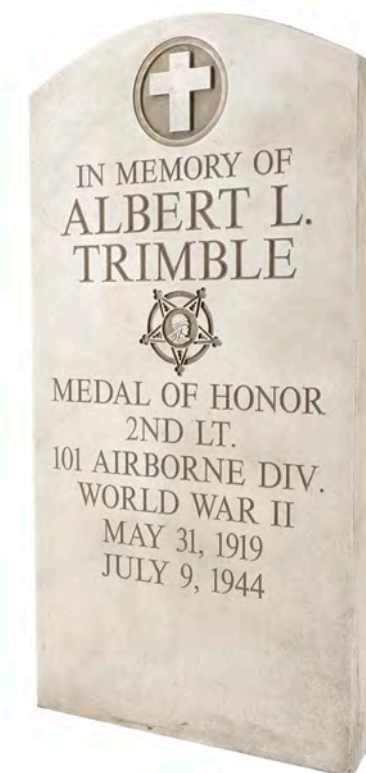

**1462**  
 King Stefan's (Sharlto Copley) Hero Sword  
 and Scabbard and King's Guard Shield  $\Omega$   
**Maleficent (2014)**

King Stefan's (Sharlto Copley) hero sword and scabbard, and a King's Guard shield, from Robert Stromberg's fantasy film Maleficent. King Stefan carried his sword for much of the film and used it during the climactic fight against Maleficent (Angelina Jolie). The King's Guard carried their shields while protecting Stefan.

This hero sword has an aluminium blade, and the scabbard is made of wood-covered leather, with a leather belt. The shield is made of wood covered with padded leather, and has a bird insignia painted on the front. Dimensions (sword): 101 cm x 27 cm x 2 cm (39.75" x 10.5" x 0.75")

**Estimate: £3,000 - 6,000**



**1463**  
 Keith Hamshere Collection: Collection of Contact Sheets  $\Omega$   
**Man On Fire (2004)**

A collection of contact sheets from the production of Tony Scott's action thriller Man on Fire. This lot comes from the personal collection of renowned stills photographer Keith Hamshere. This lot comprises 159 pages of colour contact sheets, featuring the stars Denzel Washington (John Creasy), Dakota Fanning (Lupita Ramos), Radha Mitchell (Lisa Ramos) and Christopher Walken (Paul Rayburn). The photos are a mixture of on-set photography and promotional headshots. Each page has the film title and photographer's name printed on it and the images were developed on Fujicolor Crystal Archive paper. Dimensions (each): 28 cm x 21.5 cm (11" x 8.5") Sold without copyright; see copyright notice in the Buyer's Guide.

**Estimate: £500 - 1,000**





**1464**  
**Framed Greef Karga (Carl Weathers) Chairback**  $\Omega$   
**The Mandalorian (T.V. Series, 2019-2023)**

A framed Greef Karga (Carl Weathers) chairback from the production of Jon Favreau's The Mandalorian. Karga rose from the head of the Bounty Hunters' Guild to become the High Magistrate of Nevarro over the course of the series, with help in part from his former Mandalorian hire, Din Djarin (Pedro Pascal). This black canvas chairback is emblazoned "Greef Karga" in white, Western-style font on one side. It comes mounted behind glass in a custom black frame alongside colour-printed stills of Karga, as well as Weathers seated in the character's costume from behind-the-scenes footage. The chairback exhibits some staining from production. Dimensions: (framed) 67.5 cm x 39.5 cm x 5 cm (26.5" x 15.5" x 2")

**Estimate: £1,000 - 2,000**



**1465**  
**Ridley Scott-Autographed Ares III Martian Surface Helmet Replica**  $\Omega$   
**The Martian (2015)**

A replica Ares III Martian surface helmet from Ridley Scott's sci-fi drama The Martian. The helmet was given away as a promotional gift for publicity purposes and features Ridley Scott's autograph in black marker across the visor. Designed by Scott's long-time collaborator, costume designer Janty Yates, the helmet is made from white ABS plastic with orange vinyl appliques, two model lights and a faux-silver and faux-gold painted sun visor. It displays numerous stickers, including the NASA logo, "Watney" and mission details across the back. Intentionally distressed, the helmet displays small chips and marks, and is accompanied by a display plaque. Dimensions: 38 cm x 38 cm x 31 cm (15" x 15" x 12.25") The autographs in this lot have been professionally authenticated by expert Garry King; see notice in the Buyer's Guide.

**Estimate: £2,000 - 4,000**



**1466**  
**Captain Melissa Lewis' Spacesuit Undersuit**  $\Omega$   
**The Martian (2015)**

Captain Melissa Lewis' spacesuit undersuit from Ridley Scott's The Martian. Captain Lewis wore her undersuit as she observed the changing weather patterns of an oncoming storm on Mars and prepped her crew for evacuation where they lost crew member Mark Watney (Matt Damon). This lot consists of one white and orange padded poly-blend neoprene jumpsuit with a NASA logo patch on the chest; metal components and clips; and carbon fibre hard pads on the shoulders, elbows, and knees. The interior of the jumpsuit is hand-marked "Helen" in blue ink. This lot exhibits discolouration, a buildup of grime, and adhesive residue.

**Estimate: £3,000 - 6,000**



**1467**  
**Steve Rogers' (Chris Evans) SSR T-Shirt**  $\Omega$   
**Captain America: The First Avenger (2011)**

Steve Rogers' (Chris Evans) SSR T-Shirt from Joe Johnston's superhero film Captain America: The First Avenger. World War Two hero Rogers was wearing his SSR T-shirt when he awoke in the modern day and discovered he'd been asleep for 70 years, setting the stage for Avengers Assemble the following year. SSR stands for "Strategic Scientific Reserve", the scientific unit to which Rogers was assigned during the war. The shirt is off-white with the "SSR" logo printed on the front, and it has the number "2" handwritten on its interior.

**Estimate: £2,000 - 4,000**



**1468**  
**Howard Stark's (Dominic Cooper) Aviator Jacket**  $\dagger$   
**Captain America: The First Avenger (2011)**

Howard Stark's (Dominic Cooper) aviator jacket from Joe Johnston's 2011 superhero film Captain America: The First Avenger. Stark wore his jacket while piloting the plane from which Steve Rogers (Chris Evans) jumped during his attempt to rescue Bucky Barnes (Sebastian Stan). The jacket is made of brown leather lined with shearling, and features an internal label that reads "Marvel - CAP 68702".

**Estimate: £1,500 - 3,000**



**1469**  
**Jane (Natalie Portman) Costume**  $\Omega$   
**Thor (2011)**

Jane Foster's (Natalie Portman) costume from Kenneth Branagh's superhero film Thor. Jane wore her costume during the first half of the film, in the hospital and Isabela's Diner sequences. The costume comprises a navy blue double-breasted coat, a sleeveless brown waterproof Barbour® jacket (labelled size "8"), and a pair of dark blue denim jeans (size "28"). Adhered inside the waistband of the jeans is a costuming label which reads "Marvel - THOR 62989".

**Estimate: £2,000 - 4,000**



**1470**  
Thor (Chris Hemsworth) Costume m  
**Thor (2011)**

Thor's (Chris Hemsworth) Earth costume from Kenneth Branagh's superhero film Thor. Asgardian prince Thor was given these clothes while on Earth to help him blend in, and wore them while attempting to retrieve Mjolnir, his hammer. This lot consists of a brown Ralph Lauren® jacket (labelled size "M"); a blue Lucky Brand T-shirt (size "L"); and a pair of black Levi's® jeans. The T-shirt retains its original production tag, which reads "Character: Thor; Actor: Chris Hemsworth; Change: 6,7 Earth Day: D2, N2; Scenes: 60-93 Misc.: 21-Blue T-shirts L".

**Estimate: £3,000 - 6,000**

**1471**  
Thor's (Chris Hemsworth) Screen-matched Civilian Costume m  
**Thor (2011)**

Thor's (Chris Hemsworth) screen-matched civilian costume from Kenneth Branagh's superhero film Thor. The Asgardian God of Thunder wore his outfit when he confronted the Destroyer in the New Mexico desert. The pattern on the shirt matches it to the scene in which Thor discusses the plan of attack with his friends Lady Sif (Jaimie Alexander) and the Warriors Three (Tadanobu Asano, Josh Dallas and Ray Stevenson). The costume comprises a blue-and-black check shirt, a grey T-shirt (size "XL") and a pair of Levi's® denim jeans ("W36 L34").

**Estimate: £3,000 - 6,000**



**1472**  
Lady Sif's (Jaimie Alexander) Asgardian Shield tΔ  
**Thor (2011)**

Lady Sif's (Jaimie Alexander) Asgardian shield from Kenneth Branagh's Marvel superhero film Thor. Lady Sif wielded her shield throughout the film, and Thor (Chris Hemsworth borrowed it during the battle against the Destroyer. The shield is made of resin and finished with metallic paint in a way that gives it a unique hammered steel texture and appearance. "NO ALO" is handwritten on the reverse side of the shield in black marker pen. The handles of the shield are missing. The shield is displayed in a wooden frame with a laser-cut mount board featuring movie stills, the film's title and the prop's name. This frame can be hung from a wall by its rear-sided metal hooks and wiring. Dimensions: 11.5 cm x 75 cm x 79.5 cm (4.5" x 29.5" x 31.25")

**Estimate: £3,000 - 6,000**

**1473**  
Captain America's (Chris Evans) Chest Emblem tΔ  
**The Avengers (2012)**

Captain America's (Chris Evans) chest emblem from Joss Whedon's superhero film The Avengers. Captain America wore his iconic star-shaped emblem on the chest of his costume. The resin emblem is painted silver to resemble metal and has "6" handwritten on the back in ink. There are holes at the star points where it was attached to a suit. It is displayed on a custom-made stand. Dimensions (emblem): 13 cm x 13 cm x 1 cm (5" x 5" x 0.5")

**Estimate: £3,000 - 6,000**



**1474**  
Signature Hawkeye (Jeremy Renner) Arrow m  
**The Avengers (2012)**

A Hawkeye (Jeremy Renner) arrow from Joss Whedon's action sci-fi The Avengers. Hawkeye fought with his arrows throughout the film, including during the climactic battle. The arrow comprises a plastic nock, rubber fletchings, and a resin shaft and point. Dimensions: 79 cm x 4 cm x 4 cm (31" x 1.5" x 1.5")

**Estimate: £2,000 - 4,000**



**1475**  
Light-up Starlord (Chris Pratt) Spaceship Harness and Control Panels tΔ  
**Guardians Of The Galaxy (2014)**

Light-up Starlord (Chris Pratt) spaceship harness and control panels from James Gunn's superhero film Guardians of the Galaxy. Starlord was buckled into his seat when piloting the Milano M-class spaceship by its control panels. Both items are displayed on customised stands and can be illuminated by their respective switches. The harness lights up at its buckles while the control panels do the same across their faces. Also included is a set of spare spaceship parts. Dimensions (control panels): 15 cm x 26.75 cm x 31.5 cm (6" x 10.5" x 12.5") Contains electronics; see electronics notice in the Buyer's Guide.

**Estimate: £3,000 - 6,000**



**1476**  
Vision's (Paul Bettany) Chest Emblem †Δ  
**Avengers: Age Of Ultron (2015)**

Vision's (Paul Bettany) chest emblem from Joss Whedon's superhero sequel Avengers: Age of Ultron. Vision wore his emblem on his chest after being created by the Avengers using the Mind Stone. The brass emblem features a hook on the rear side which attached it to the costume. It is displayed on a custom-made stand. Dimensions: 8 cm x 6.5 cm x 1 cm (3.25" x 2.5" x 0.5")

**Estimate: £2,000 - 4,000**



**1477**  
Baron Mordo's (Chiwetel Ejiofor)  
Hero and Stunt Sling Rings †Δ  
**Doctor Strange (2016)**

Baron Mordo's (Chiwetel Ejiofor) hero and stunt sling rings from Scott Derrickson's superhero film Doctor Strange. Mordo kept his sling ring attached to his robe and wore it as he trained Dr. Strange. The hero ring is made from metal, while the stunt is rubber. Dimensions (hero ring): 9.5 cm x 1.75 cm x 4 cm (3.75" x 0.75" x 1.5")

**Estimate: £2,000 - 4,000**



**1478**  
Rehearsal Sling Ring Ω  
**Doctor Strange (2016)**

A sling ring from Scott Derrickson's Doctor Strange. Sorcerers-in-training, including Doctor Stephen Strange (Benedict Cumberbatch), used sling rings while practising at Kamar-Taj. The brass metal ring features two loops for fingers and has intricate carved detailing throughout. It exhibits intentional distressing to appear well-used and exhibits a loop that is susceptible to bending. Dimensions: 7.25 cm x 3.25 cm x 1.5 cm (3" x 1.25" x 0.75")

**Estimate: £2,500 - 5,000**



**1479**  
Corvus Glaive's (Michael James Shaw) Spearhead m  
**Avengers: Infinity War (2018)**

Corvus Glaive's (Michael James Shaw) spearhead from Anthony and Joe Russo's superhero film Avengers: Infinity War. Glaive, an ally of Thanos (Josh Brolin) used his spear when attacking Vision (Paul Bettany) and Wanda (Elizabeth Olsen) in Scotland, as well as during the Battle of Wakanda. The spearhead is made of rubber, painted to look gold. It has a metal interior, and the paintwork is done to give the impression of tarnishing. There is some paint wear on the item, and the top of the spearhead has been broken off, but otherwise it remains in good condition. Dimensions: 56 cm x 49 cm x 4 cm (22" x 19.25" x 1.5")

**Estimate: £1,000 - 2,000**

**1480**  
Stark Industry Decals and Panels †Δ  
**Avengers: Endgame (2019)**

Stark Industry decals and panels from Anthony and Joe Russo's 2019 superhero film Avengers: Endgame. Panels and decals decorated the crates on which Bruce Banner (Mark Ruffalo) propped his equipment while experimenting with sending Ant-Man (Paul Rudd) through time. This lot comprises four sheets of stickers and six panels, which feature various barcodes, serial numbers and the Stark Industries logo. The panels are printed onto sheets of aluminium. Dimensions: 37 cm x 17 cm x 1 cm (14.5" x 6.75" x 0.5")

**Estimate: £750 - 1,500**

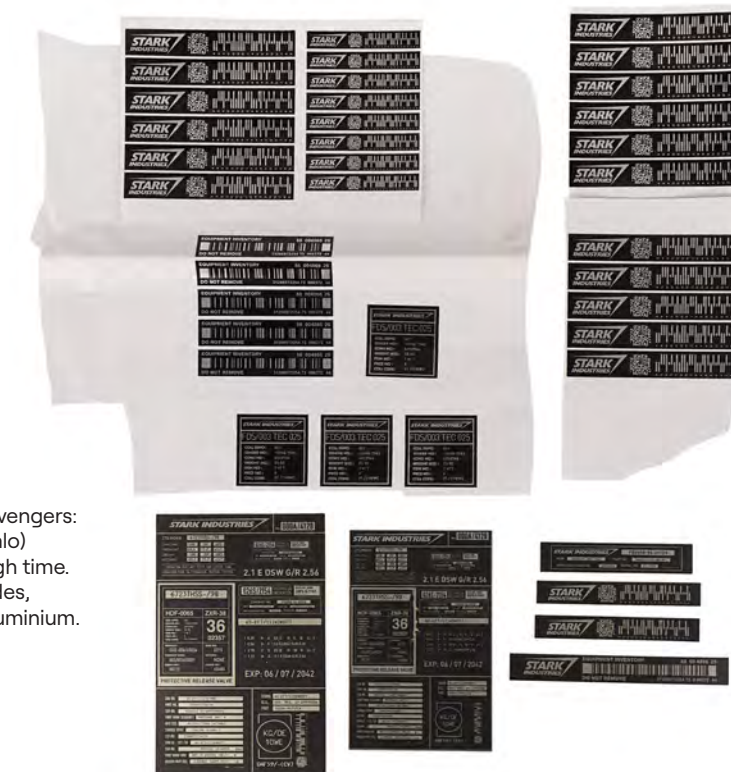

**1481**  
Black Widow's (Scarlett Johansson) Stunt Pistol m  
**Black Widow (2021)**

Black Widow's (Scarlett Johansson) stunt pistol from Cate Shortland's action-adventure film Black Widow. Black Widow defended herself with her gun when ambushed by Taskmaster (Olga Kurylenko) near the film's start ambushed her. The pistol was later used in the film's climax, notably when Black Widow was disarmed of it by Dreykov (Ray Winstone), utilising the pheromone lock installed within her. Made from foam rubber and designed for use during stunt scenes, this pistol has been painted black to appear as metal. It features a textured grip and accurate gun specifications engraved along the barrel. Dimensions: 15.25 cm x 11.5 cm x 3 cm (6" x 4.5" x 1.25") Restricted ownership; see replica firearm notice in the Buyer's Guide.

**Estimate: £2,000 - 4,000**



**1482**  
Hand-Drawn John Buscema and Joe Sinnott  
Thor No. 225 Pg. 3  
**Marvel Comics**

Page 3 of Thor issue 225 published by Marvel Comics in July 1974 titled "The Coming of the Firelord!" The issue, which featured the first appearance of Firelord, was written by Gerry Conway with pencils by John Buscema and inks by Joe Sinnott. This seven-panel comic art page featuring Thor and Destroyer is marked "Thor," "225," and "3" in ink and graphite. It exhibits staining and adhesive residue throughout, as well as a Supersnipe stamp and price label on the reverse. Dimensions: 27.5 cm x 40.75 cm (10.75" x 16") Sold without copyright; see copyright notice in the Buyer's Guide.

**Estimate: £2,000 - 4,000**



**1483**  
Tom Hiddleston and Cast-Autographed Poster m  
**Loki (T.V. Series, 2021-Present)**

A poster autographed by Tom Hiddleston and the cast of superhero TV show Loki. This poster has been autographed by stars Hiddleston (Loki), Sophie Di Martino (Sylvie), Gugu Mbatha-Raw (Ravonna Renslayer) Owen Wilson (Mobius M. Mobius) and Wunmi Mosaku (Hunter B-15). The poster has some minor wear and staining. Dimensions: 56 cm x 46 cm (22" x 18") The autographs in this lot have been professionally authenticated by expert Garry King; see notice in the Buyer's Guide.

**Estimate: £800 - 1,600**

**1484**  
Creature (Robert De Niro) Facial Bust, Teeth, Foot  
Appliance, Production Script and Call Sheet m  
**Mary Shelley's Frankenstein (1994)**

A Creature (Robert De Niro) facial bust, teeth, and foot appliance, accompanied by a production script and call sheet, from Kenneth Branagh's horror adaptation of Mary Shelley's Frankenstein. The elements of Creature's appearance were created and formed by Daniel Parker, who was nominated for his work on the film at the 1995 Oscars. The fibreglass bust is moulded to resemble his face, while it has been partly covered in foam rubber skin during the design process to speculate on and practise the creation of what Creature's appearance would be. The foot appliance is also made of foam rubber, with an inner fabric layer to provide comfort for the wearer. The prosthetic teeth are made of plastic. The call sheet lists scheduled times for cast and crew members, including Branagh and De Niro. The full-length script has a total page count of 108, with "120" handwritten in red marker pen in the top right corner of the title page. The script exhibits significant wear and stains. Dimensions: (Creature bust) 28 cm x 22 cm x 39.5 cm (11" x 8.75" x 15.5")

**Estimate: £1,500 - 3,000**



**1485**  
The Mask's (Jim Carrey) Alarm Clock m  
**The Mask (1994)**

The Mask's (Jim Carrey) alarm clock from Chuck Russell's The Mask. The Mask, Stanley Ipkiss' alter ego activated by a Nordic Loki Mask, smashed an alarm clock outside of Mrs. Peenman's apartment while trying to stay quiet. The Mask was a critical and commercial success, and was nominated for the Academy Award® for Best Visual Effects. At the time, it was considered the most profitable movie based on a comic series published by Dark Horse Comics. This lot consists of a blue painted metal Spartan clock with a paper insert face with a plastic holder, metal arms, and metal bells. This clock is intentionally deformed from production and exhibits minor chipping paint and discolouration. Dimensions: 18 cm x 11.5 cm x 5 cm (7" x 4.5" x 2")

**Estimate: £3,000 - 6,000**



**1487**  
Eternian Soldier Costume m  
**Masters Of The Universe (1987)**

An Eternian soldier costume from Gary Goddard's fantasy adventure Masters of the Universe. Eternian soldiers wore their uniforms after the battle with Skeletor's (Frank Langella) army. The vacuum-formed plastic armour, just like the rest of the costume, is intentionally designed to appear battle-worn, while "#15" has been handwritten in marker pen on the inside of the torso plate. The boots are grey-painted Adidas trainers embellished with production-added details.

**Estimate: £2,000 - 4,000**



**1486**  
Cast-Autographed B-2 Eastman Aviator Cap m  
**Masters Of The Air (T.V. Series, 2024)**

A cast-autographed B-2 Eastman Aviator cap from the production of Apple TV's WW2 drama series Masters of the Air. The cap has been autographed in gold marker pen by Callum Turner (Maj. John 'Bucky' Egan), Austin Butler (Maj. Gale 'Buck' Cleven), Anthony Boyle (Lt. Harry Crosby), Rafferty Law (Sgt. Ken Lemmons), James Murray (Col. 'Chick' Harding), Samuel Jordan (Sgt. John J. 'Winks' Herrmann), Stephen Campbell Moore (Maj. 'Red' Bowman), Edward Ashley (Maj. Jack Kidd), James Frecheville (Maj. Bill Veal), Ben Radcliffe (Lt. John Brady), Nathan Solly (Lt. John Hoerr), Nate Mann (Lt. Robert 'Rosie' Rosenthal), and Adam Long (Cpt. Benny DeMarco). "Gunot" is handwritten on the inside label of this leather and sheepskin cap. The autographs in this lot have been professionally authenticated by expert Garry King; see notice in the Buyer's Guide.

**Estimate: £2,000 - 4,000**



**1488**  
Skeletor's (Frank Langella) Armour and Light-Up Gauntlets α  
**Masters Of The Universe (1987)**

Skeletor's (Frank Langella) armour with light-up gauntlets from Gary Goddard's Masters of the Universe. After taking control of Castle Grayskull and absorbing the powers of the universe, Skeletor transformed himself into a god-like figure clad in golden armour. This lot consists of ornately detailed fibreglass chest armour with leather shoulder straps, shoulder plates, snap-button closures, and a belt marked "D," all padded with cloth-wrapped foam painted gold; a matching lame-blend high-collared shoulder; matching gloves with skull-shaped fingertips sewn on; a leatherette belt with matching pteruges; and a pair of cast resin gauntlets painted gold with fastening strip closures. The gauntlets feature multiple lights designed to illuminate in sequence when they are connected to an AC power outlet. Also included is a custom-made, velvet-lined wooden display base with gold-colour mesh gloves. This lot exhibits peeling cloth on the shoulder pads, wrinkling in the pteruges, and chipped paint throughout. Contains electronics; see electronics notice in the Buyer's Guide.

**Estimate: £5,000 - 10,000**



**1489A**  
Hand-Illustrated Lois DeArmond Trinity (Carrie-Anne Moss) Costume Concept Sketch α  
**THE MATRIX (1999)**

A costume concept sketch for Trinity (Carrie-Anne Moss) hand-illustrated by Lois DeArmond for Lana and Lilly Wachowski's The Matrix. DeArmond worked as a costume illustrator for the film.

This pencil drawing of Trinity standing with her hands on her hips in a vested outfit is on tracing paper stapled over drawing paper, is signed "DeArmond '97," and has two magazine cut-outs of different types of shoes taped to it and handwritten annotations from costume designer Kym Barrett. It exhibits pinholes, edge wear, and minor stains. Dimensions: 35.75 cm x 43.25 cm (14" x 17")

Sold without copyright; see notice in the Buyer's Guide.

**Estimate: £1,000 - 2,000**



13 cm (5")

**1489**  
Tracker Bug Probe α  
**The Matrix (1999)**

A tracker bug probe from the Wachowskis' sci-fi action film The Matrix. Neo (Keanu Reeves) had a tracker bug planted inside him through his navel by the Agents. This tail section of a bug consists of a piece of custom-moulded white translucent rubber with a hollow centre section where an animatronic armature would be placed to create movement. The end of the tail exhibits a slight bend. Dimensions: 13 cm x 3 cm x 3 cm (5" x 1.25" x 1.25")

**Estimate: £600 - 1,200**



**1489B**  
Hand-Illustrated Lois DeArmond Neo (Keanu Reeves) Dojo Costume Concept Sketch α  
**THE MATRIX (1999)**

A costume concept sketch for Neo (Keanu Reeves) hand-illustrated by Lois DeArmond for Lana and Lilly Wachowski's The Matrix. DeArmond worked as a costume illustrator for the film.

This pencil drawing of Neo standing in a neutral pose in his dojo costume is on tracing paper stapled over drawing paper, is signed "DeArmond '97," and features hand-written annotations from costume designer Kym Barrett. It exhibits edge wear and minor stains. Dimensions: 35.75 cm x 43.25 cm (14" x 17")

Sold without copyright; see notice in the Buyer's Guide.

**Estimate: £1,000 - 2,000**



**1489C**  
Hand-Illustrated Lois DeArmond Trinity (Carrie-Anne Moss) Costume Concept Painting α  
**THE MATRIX (1999)**

A costume concept painting for Trinity (Carrie-Anne Moss) hand-illustrated by Lois DeArmond for Lana and Lilly Wachowski's The Matrix. DeArmond worked as a costume illustrator for the film.

This full-colour painting of Trinity standing with her hands on her hips in a vested outfit is on illustration board and is signed "DeArmond '97" with fabric swatches stapled to it and a black paper cover. It exhibits some tearing to the cover. Dimensions: 43.25 cm x 51 cm (17" x 20")

Sold without copyright; see notice in the Buyer's Guide.

**Estimate: £2,500 - 5,000**



**1489D**  
 Hand-Illustrated Lois DeArmond Neo (Keanu Reeves)  
 Costume Concept Painting  
**THE MATRIX (1999)**

A costume concept painting for Neo (Keanu Reeves) hand-illustrated by Lois DeArmond for Lana and Lilly Wachowski's The Matrix. DeArmond worked as a costume illustrator for the film.

This full-colour painting of Neo standing in a neutral pose in black body armour is on illustration board and is signed "DeArmond '97" with a black paper cover. It exhibits some wear to the cover. Dimensions: 38.25 cm x 51 cm (15" x 20")

Sold without copyright; see notice in the Buyer's Guide.

**Estimate: £2,500 - 5,000**



**1490**  
 Viking Bust from Merovingian's (Lambert Wilson)  
 Chateau  
**The Matrix Reloaded (2003)**

A viking bust from Merovingian's (Lambert Wilson) chateau from Lana and Lilly Wachowski's The Matrix Reloaded. Statues decorated the room at Merovingian's mountain chateau where his men attacked Neo (Keanu Reeves). This plaster bust depicts a Viking (modelled after supervising art director Hugh Bateup) with a long moustache, a winged helmet, long hair, and billowing fabric around the shoulders. It is painted and finished to resemble white marble. This bust exhibits pitting, discolouration at the base, and chipped paint and plaster exposing white plaster underneath. Dimensions: 63.5 cm x 40.75 cm x 68.5 cm (25" x 16" x 27")

**Estimate: £4,000 - 8,000**

**1491**  
 Max Headroom's (Matt Frewer) Jacket  
**Max Headroom (T.V. Series, 1987-1988)**

Max Headroom's (Matt Frewer) jacket from the sci-fi TV series Max Headroom. Headroom was a computerised version of investigative journalist Edison Carter, who appeared throughout the series, gaining information from TV networks or simply reacting to the events that unfolded in each episode. Headroom appeared in either a black or a white suit with this static jacket designed for the latter costume. The jacket, which is joined together by four metal screws, is made of fibreglass. It comes with a replica bow tie and replica sunglasses, both made of plastic, and a resin Headroom display head that can be slid down and positioned on the accompanying wooden stand. Dimensions: 27 cm x 70 cm x 62.5 cm (10.75" x 27.5" x 24.5")



**Estimate: £2,000 - 4,000**



**1492**  
 Collection of Printed Storyboards, Script, Crew T-Shirt,  
 Bullet, Film Stills and Production Paperwork  
**Memphis Belle (1990)**

A collection of storyboards, a script, a crew T-shirt, a bullet, stills and assorted paperwork from the production of Michael Caton-Jones' World War II film Memphis Belle. The lot includes a 124-page script dated "July 3, 1989"; 233 pages of printed storyboards bound together by a metal fastener; a green "Film Crew 89" T-shirt (size XL); a metal .45 FA 4 bullet; thirteen black-and-white stills credited to photographer David Appleby; a cast and crew screening ticket; and a selection of paperwork relating to the set construction including costs lists and a revised budget sheet. The script comes in a red card cover and includes a Memphis Belle diagram. There are signs of tarnishing on the bullet, and the paperwork displays minor creasing and marks. Dimensions: (script): 30.25 cm x 21.5 cm x 1.5 cm (12" x 8.5" x 0.5")

**Estimate: £500 - 1,000**

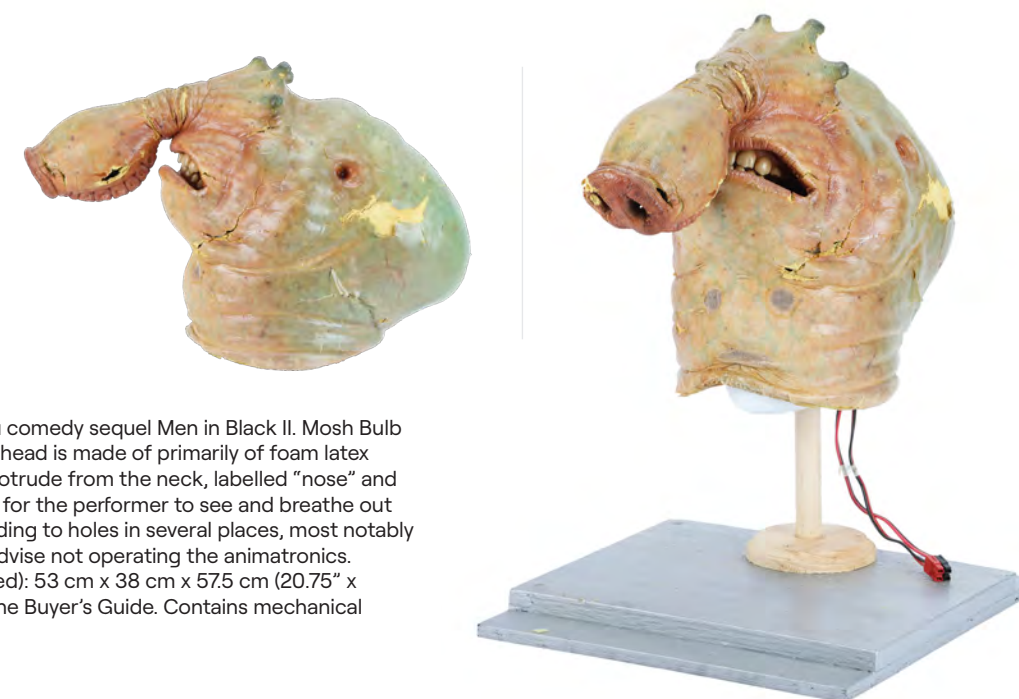

**1493**  
 Mosh Bulb Animatronic Head  
**Men In Black II (2002)**

A Mosh Bulb animatronic head from Barry Sonnenfeld's sci-fi comedy sequel Men in Black II. Mosh Bulb is a Doldunian and can be seen at the MiB headquarters. The head is made of primarily of foam latex with resin teeth. It has been airbrushed and a pair of wires protrude from the neck, labelled "nose" and "lips" respectively. There are small mesh air holes in the neck for the performer to see and breathe out of. The foam latex is fragile and has come away in places, leading to holes in several places, most notably on the neck and face. To maintain its current condition, we advise not operating the animatronics. It is displayed on a custom-made stand. Dimensions (displayed): 53 cm x 38 cm x 57.5 cm (20.75" x 15" x 22.75") Contains electronics; see electronics notice in the Buyer's Guide. Contains mechanical components; see mechanical notice in the Buyer's Guide.

**Estimate: £1,500 - 3,000**



**1494**  
Baby Joe (Verne Troyer) Costume Display with Mechanical Head  $\Omega$   
**Mighty Joe Young (1998)**

A Baby Joe (Verne Troyer) costume display with a mechanical head from Ron Underwood's *Mighty Joe Young*. The titular gorilla was just a baby when his mother was killed by poachers and Jill Young (Mika Boorem), then still a child herself, promised to protect him. Created by SFX makeup artist Rick Baker's Cinovation Studios, this gorilla suit is built from foam latex with black faux fur punched throughout and resin teeth and brown acrylic eyes inset in the face. The head features mechanical pulleys designed to articulate the gorilla's jaw from the interior, as well as a fibreglass bust of Troyer for stability. The costume comes displayed on a custom-made black stand featuring the film's title logo. The foam latex exhibits hardening from age. Dimensions: (displayed) 51 cm x 61 cm x 81.5 cm (20" x 24" x 32") Contains mechanical components; see notice in the Buyer's Guide.

**Estimate: £2,500 - 5,000**



**1494A**  
Set of Six Production-made Power Coins  $\Omega$   
**Mighty Morphin Power Rangers: The Movie (1995)**

A set of six production-made power coins from Bryan Spicer's *Mighty Morphin Six* power coins from the production of Bryan Spicer's *Mighty Morphin Power Rangers: The Movie*. The Power Rangers used individual power coins forged by Ninjor as their main power sources. This set of resin power coins engraved with Tyrannosaurus, Triceratops, Pterodactyl, Mastodon, Sabre-toothed Tiger, and White Tiger symbols and painted gold-colour was created from the production moulds by production manufacturer Global Effects Inc., who also produced props and costumes for the promotional campaign. They exhibit chipping to the paint and in the resin along the edges. Dimensions: (each) 3.25 cm x 3.25 cm x 0.5 cm (1.25" x 1.25" x 0.25")

**Estimate: £3,000 - 6,000**



**1495**  
Billy Cranston's (David Yost) Promotional Blue Ranger Suit  $\Omega$   
**Mighty Morphin Power Rangers: The Movie (1995)**

Billy Cranston's (David Yost) promotional Blue Ranger suit from Bryan Spicer's *Mighty Morphin' Power Rangers: The Movie*. This blue, white, and gold costume was specifically made for promotional events and differs from the costumes seen in the film's final cut. This costume consists of foam rubber chest, back, thigh, and shoulder armour with glue and fastening strip closures; a spandex undersuit; a gold-colour resin wolf spirit chest emblem; a belt apparatus replica produced by the maker of the promotional touring suits; and a matching pairs of boots. Also included are a pair of replica gloves and a replica helmet moulded from a production original with a padded interior, dark tinted visor, and vents under the nose and on the back. The lot exhibits cracking throughout the helmet, loose and sticky adhesive residue, deterioration to the foam rubber and boot soles, paint flaking, and discolouration throughout.

**Estimate: £3,000 - 6,000**

**1496**  
Precrime Officer Joanov's Light-Up Helmet  $\Omega$   
**Minority Report (2002)**

Precrime Officer Joanov's light-up helmet from Steven Spielberg's *Minority Report*. In 2054 Washington D.C., a team of law enforcement officers wore tactical helmets and uniforms as they apprehended criminals before they committed crimes. This grey background officer helmet is constructed of fibreglass and vacuum-formed panels with the name "Joanov" printed on it and features a clear acrylic visor, custom-made foam lining, interior mechanics, and electronics. It features a servo-powered, drop-down illuminating visor that is deployed and powered "on" via two buttons on the side of the helmet. Two 9V batteries are stored in the back of the helmet behind a removable piece of padding. Along with the visor, the earpieces (which feature the precrime unit logo) illuminate with LEDs. It exhibits signs of use and age throughout, including scuffing throughout and tearing in the padding. Contains electronics; see electronics notice in the Buyer's Guide.

**Estimate: £3,000 - 6,000**



No Lot 1497



**1498**  
Set of Six Neuron Inhalers  $\Omega$   
**Minority Report (2002)**

A set of six neuron inhalers from Steven Spielberg's *Minority Report*. Used inhalers were seen near the beginning of the film when John Anderton (Tom Cruise) emptied his pockets before watching old films of his wife and child, and later in the film when Danny Whitwer (Colin Farrell) snooped through John's apartment. This lot consists of six white, black, pink, blue, and grey resin inhalers. Three inhalers feature inflated "bubbles" while three feature collapsed bubbles. These inhalers exhibit grime and minor chipped paint. Dimensions: (each) 5.5 cm x 5 cm x 2 cm (2.25" x 2" x 0.75")

**Estimate: £1,000 - 2,000**

**1499**  
Set of Eyeballs and Seahorse Figure  $\pm\Delta$   
**Miss Peregrine's Home For Peculiar Children (2016)**

A set of eyeballs and a seahorse figure from Tim Burton's time-warp fantasy *Miss Peregrine's Home for Peculiar Children*. Mr. Barron (Samuel L. Jackson) and the Hollowgasts consumed the eyeballs of Peculiar to evolve into a human-like form with milky-white eyes known as Wights. This style of seahorse figure is not seen on screen. The four silicone eyeballs feature a light blue-grey coloured iris and several nerve strands hanging from the back. The gold-coloured resin seahorse figure comes with a round metal display base allowing it to stand upright. The paint finish has worn away where the figure inserts into the base. Dimensions (seahorse displayed): 10.5 cm x 10.5 cm x 31 cm (4.25" x 4.25" x 12.25"); (largest eyeball): 13 cm x 3 cm x 3 cm (5.25" x 1.25" x 1.25")

**Estimate: £400 - 800**





**1500**  
 Mr. Barron's (Samuel L. Jackson ) Weapon Arms, Beating Heart Jar, and Helmet m  
**Miss Peregrine's Home For Peculiar Children (2016)**

Mr. Barron's (Samuel L. Jackson) weapon arms, beating heart jar, and helmet from Tim Burton's fantasy film Miss Peregrine's Home for Peculiar Children. Barron could turn his arm into any weapon of his choosing, such as a spear or axe, and wore his helmet when participating in the medical experiment that turned him into a Hollowgast. The helmet is made of resin, and the weapon arms are made of foam, and all three have been painted to look metallic. The axe hand has an open end so the hand can be inserted, and a metal pole within for grip. The beating heart is functional, with wires protruding from the bottom that create the beating effect when connected to an electrical source. The jar has been replaced since production, and there is some paint wear on both arms, but otherwise the items remain in very good condition. Dimensions: 62 cm x 62 cm x 38 cm (24.5" x 24.5" x 15") Contains electronics; see electronics notice in the Buyer's Guide.

**Estimate: £1,000 - 2,000**



**1501**  
 Set of Ethan Hunt's (Tom Cruise) Exploding Gum m  
**Mission: Impossible (1996)**

A set of Ethan Hunt's (Tom Cruise) exploding gum from Brian De Palma's action film Mission: Impossible. Exploding gum was used by Ethan Hunt (Tom Cruise) throughout the film, most notably when he destroyed the helicopter in the Channel Tunnel, ultimately killing the villainous Jim Phelps (Jon Voight) and Franz Krieger (Jean Reno). The lot comprises seven sticks of foil-wrapped foam latex chewing gum and five paper branded 'Two-in-One Gum' wrappers. Dimensions: 9.25 cm x 2.25 cm (3.75" x 1")

**Estimate: £1,000 - 2,000**



Tom Cruise autograph detail



**1502**  
 Tom Cruise, Rebecca Ferguson, Simon Pegg and Cast-Autographed Clapperboard m  
**Mission: Impossible-Rogue Nation (2015)**

A cast-autographed clapperboard from the production of Christopher McQuarrie's action sequel Mission: Impossible - Rogue Nation. The back of this acrylic clapperboard has been autographed in black ink by five principal cast members: Tom Cruise (Ethan Hunt), Rebecca Ferguson (Isla Faust), Simon Pegg (Benji Dunn), Jeremy Renner (William Brandt) and Alec Baldwin (Alan Hunley). The front of the clapperboard features the film's working title "Taurus", a piece of clear tape dated "16 Dec '14", and several handwritten notes, including take number, scene number and camera lens. Dimensions: 23.5 cm x 28.5 cm x 2.5 cm (9.25" x 11.25" x 1") The autographs in this lot have been professionally authenticated by expert Garry King; see notice in the Buyer's Guide.

**Estimate: £4,000 - 8,000**

**1503**  
 David's (Thomas Jane) Opening Scene Prop Painting m  
**The Mist (2007)**

David's (Thomas Jane) opening scene prop painting from Frank Darabont's horror The Mist. Artist David created movie-themed paintings and was painting a The Dark Tower-inspired piece when the storm hit his house at the film's beginning. The art is by famed poster artist Drew Struzan, who created this print specially for the production. Struzan has created poster art for dozens of classic films, including the original Star Wars trilogy, the Back to the Future trilogy, the Indiana Jones series, The Shawshank Redemption, Blade Runner and many, many more. It is displayed in a custom-made frame and exhibits intentional distress, including water damage and other markings, from the storm. Dimensions: 113 cm x 83 cm x 3 cm (44.5" x 32.75" x 1.25")

**Estimate: £2,000 - 4,000**



**1504**  
 Lunar Industries LTD Sign and Harvester System Operations Sheet m  
**Moon (2009)**

A Lunar Industries LTD sign and a Harvester system operations sheet from Duncan Jones' sci-fi mystery Moon. Countdown signs were attached to the walls in the Moon base and were used to track the status of four 'harvester' mining vehicles. System operations screens were seen onboard these harvesters. The information displayed on the sign is fixed; however, during the film, it was changed using digital effects. The sheet is a laminated graphic that would have been slotted into a screen and illuminated with special effects. The sign's decals exhibit minor peeling. Dimensions: 68 cm x 40.5 cm x 9.75 cm (26.75" x 16" x 3.75") Contains electronics; see electronics notice in the Buyer's Guide.

**Estimate: £1,000 - 2,000**

**1505**  
 Pair of Him's (Javier Bardem) Poetry Books and Prayer Cards m  
**Mother! (2017)**

A pair of Him's (Javier Bardem) poetry books and holy cards from Darren Aronofsky's Mother! Crowds of adoring fans brought their books to the house for Him to sign and covered the door to his study in prayer cards using his image. This lot consists of two white poetry books with many of the pages being cropped-in detail shots of the same image from the first page, and two cardstock prayer cards of Him. The back of the poetry books feature a debossed image of Him. Production intentionally distressed this lot. This lot exhibits creasing, edge tearing, and discoloration. Dimensions: (largest) 14 cm x 14 cm x 1.25 cm (5.5" x 5.5" 0.5")

**Estimate: £800 - 1,600**







**1506**  
John Smith's (Brad Pitt) Headpiece  $\Omega$   
**Mr. & Mrs. Smith (2005)**

John Smith's (Brad Pitt) headpiece from Doug Liman's action comedy Mr. & Mrs. Smith. John wore his headpiece while he crawled through the pipes on his way to kidnap Danz (Adam Brody). This lot consists of one plastic headset with a rubber ear piece and a polyurethane camera. The camera features metal components and static multicoloured buttons. This lot exhibits worn elastic and a buildup of grime, as well as scratches and divots in the plastic. Dimensions: 20.5 cm x 15.25 cm x 7.75 cm (8" x 6" x 3")

**Estimate: £1,000 - 2,000**

**1507**  
Mrs. Doubtfire (Robin Williams) Head Replica  $\Omega$   
**Mrs. Doubtfire (1993)**

A replica of Mrs. Doubtfire's (Robin Williams) head from Chris Columbus' Mrs. Doubtfire. Daniel Hillard disguised himself as Mrs. Doubtfire in order to secretly spend more time with his children following his divorce from his wife, Miranda (Sally Field). Created based on the Oscar-winning® makeup by Greg Cannom, Ve Neill, and Yolanda Toussieng, this foam-filled head depicting Hillard in his Doubtfire disguise is painted with tan skin, bright pink lips, highly detailed grey-blue acrylic eyes with black eyelashes, a removable blond wig, and a pair of transparent pink acrylic eyeglasses. The wig is messed from handling and the painted skin exhibits some chipping. Dimensions: 23 cm x 18 cm x 30.5 cm (9" x 7" x 12")

**Estimate: £1,200 - 2,400**



**1508**  
Canopic Jar Production Lids  $\Omega$   
**The Mummy (1999)**

A set of canopic production lids from Stephen Sommers' fantasy adventure The Mummy. Canopic jars were seen in the film's opening scenes in Hamunaptra, the City of the Dead, when Imhotep (Arnold Vosloo) was buried alive with flesh-eating scarabs. These 16 lids were created for various purposes, such as finalising the aesthetic of those seen in the final cut and making moulds to produce more versions. The lids also vary in their construction, with materials used ranging between plaster, rubber and wax. Some of the lids exhibit minor wear and breakage from production use. Dimensions (one lid): 9 cm x 9 cm x 10 cm (3.5" x 3.5" x 4")

**Estimate: £1,000 - 2,000**



**1509**  
Dr. Terrence Bay's (Erick Avari) Stunt Sword  
and Ardeth Bay's (Oded Fehr) Black Robe Costume  $\Omega$   
**The Mummy (1999)**

Dr. Terrence Bay's (Erick Avari) stunt sword and Ardeth Bay's (Oded Fehr) black robe costume from Stephen Sommers' The Mummy. Dr. Bay used his sword when the living dead minions of Imhotep (Arnold Vosloo) closed in on him in the town and he protected the others by sacrificing himself. Ardeth wore his costume as he joined Rick O'Connell's (Brendan Fraser) team in saving the world from Imhotep. This lot consists of a heavy black cotton cloak with creased black nylon panels, black-and-white woollen braids fixed to the shoulder, a silver-colour sash belt, matching black cotton trousers and a dark blue sash; and a black and silver-colour rubber sword with gold-colour painted details and a curved blade. The coat collar features decorative silver-colour stitching and patterned front lapels and all fastened with simple black ties. There is a small label inside the long coat that reads 'Oded Fehr - Ardeth Bay' on an Angels costumers label. This lot exhibits minor loose threads and chipped paint. Dimensions: (sword) 94 cm x 7.75 cm x 5 cm (37" x 3" x 2")

**Estimate: £1,500 - 3,000**



**1510**  
Background Corpse  $\Omega$   
**The Mummy Returns (2001)**

A background corpse from Stephen Sommers' 2001 adventure film The Mummy Returns. Corpses were seen in the background of a number of scenes in the pyramid. The corpse is deliberately incomplete, consisting only of a torso, one arm, and a nearly decapitated head. It is made of foam latex, painted green and brown to mimic decay, and a metal rod inserted in the arm keeps it posed at a bent angle. The foam is exposed on the back of the torso, and the metal rod in the arm protrudes through the back of its shoulder, but otherwise it remains in very good condition. Dimensions: 51 cm x 51 cm x 20 cm (20" x 20" x 8")

**Estimate: £1,000 - 2,000**



**1511**  
Crystallised Imhotep (Arnold Vosloo) Mummy Head  
Crew Gift  $\Omega$   
**The Mummy Returns (2001)**

A crystallised Imhotep (Arnold Vosloo) mummy head crew gift from the production of Stephen Sommers' fantasy-adventure sequel The Mummy Returns. A visage of the tortured face of Imhotep, this resin mummy head and others like it were gifted to the production's crew members. Dimensions: 24 cm x 25 cm x 25.5 cm (9.5" x 9.75" x 10")

**Estimate: £800 - 1,600**



**1512**  
**Imhotep (Arnold Vosloo) Make-up Test Bust m**  
**The Mummy Returns (2001)**

An Imhotep (Arnold Vosloo) make-up test bust from the production of Stephen Sommers' action-adventure sequel, The Mummy Returns. This bust was created during pre-production to assist in visualising and designing Imhotep's appearance in the film. It is also possible that this bust was used for VFX scanning. The bust is made of fibreglass, overlaid with rubber that has then been painted and modified to create the character's look. The eyes are resin. Dimensions: 24 cm x 50 cm x 41 cm (9.5" x 19.75" x 16.25")

**Estimate: £800 - 1,600**

**1513**  
**Four Set Pieces m**  
**The Mummy (1999) / Mummy Returns (2001)**

Four set pieces from Stephen Sommers' action-adventure film The Mummy and his follow-up sequel The Mummy Returns. The lot comprises a plaster temple slab with hieroglyphs, a plaster decorative beetle piece, a plastic gold-coloured hieroglyph panel, and a plastic Sudan boat sign. Beetles were seen hanging during the resurrection ritual at the film's start. Gold walls featuring hieroglyphs were seen in the chamber where the Book of Amun-Ra was found. The Sudan was the boat on which the main characters were transported to Hamunaptra, the City of the Dead. Dimensions: 151.25 cm x 3 cm x 116.25 cm (59.5" x 1.25" x 45.75")

**Estimate: £1,000 - 2,000**



**1514**  
**Collection of Production Ephemera m**  
**The Muppet Christmas Carol (1992)**

A collection of production ephemera from the production of Brian Henson's Christmas musical film The Muppet Christmas Carol. Included in this lot is a crew gift statuette, a size "XXL" bomber style jacket, paperwork, floor plans, concept art, and behind-the-scenes photos. The statuette features Bob (Kermit the Frog) holding his top hat with Tiny Tim (Robin the Frog) sat on his shoulder. It is made of brass, and the base features engraved text reading "With Thanks, Brian". The jacket is embroidered with an image of Bob and Tim, with embroidered text that reads "The Muppet Christmas Carol Film Crew 1992 V.G.S." on the front. Dimensions: 40 cm x 30 cm x 25 cm (15.75" x 12" x 10")

**Estimate: £1,000 - 2,000**



**1515**  
**Crew Jacket and Tankard m**  
**Muppet Treasure Island (1996)**

A crew jacket and tankard from the production of Brian Henson's 1996 musical swashbuckler Muppet Treasure Island. The jacket is a black bomber jacket, which is labelled size "M", quilted inside, and features the Muppet Treasure Island logo embroidered on the back. The tankard is decorated with various Muppet characters, and an engraved message on the side reads, "May the wind be always at your back! Thanks for everything, Brian and Martin." The jacket exhibits some staining on the exterior and some thread pulling on the lining, but otherwise both items remain in very good condition.

**Estimate: £600 - 1,200**



**1516**  
**Collection of Production Ephemera m**  
**Muppet Treasure Island (1996)**

A collection of ephemera from the production of Brian Henson's musical comedy Muppet Treasure Island. Included in the collection are various concept art pieces of ships, sceneries, and characters, a script, production notes, and correspondence, as well as a crew gift tankard. The tankard is decorated with various muppet characters from the film, and an engraved message on the side reads "May the wind be always at your back! Thanks for everything, Brian and Martin." Some of the paperwork has been rolled or folded for storage, but overall all the items remain in very good condition. Dimensions: 40 mc x 30 cm x 25 cm (15.75" x 12" x 10")

**Estimate: £1,000 - 2,000**



**1517**  
**Set of Gold Bars and Coins m**  
**Muppet Treasure Island (1996)**

Gold bars and coins from Brian Henson's musical comedy film Muppet Treasure Island. Long John Silver (Tim Curry) and his men hunt for, and find, a stash of treasure on a remote island. Included in the lot are four gold bars, made of biscuit foam and painted gold, and three Roman-style coins, made of plastic and painted gold. The bars exhibit some chipping in the foam, and all the items exhibit some paint wear. Dimensions: 24 cm x 20 cm x 15 cm (9.5" x 7.75" x 6")

**Estimate: £1,000 - 2,000**





**1518**  
**Collection of Production Ephemera from Muppets in Space and Elmo in Grouchland m**  
**The Muppets Franchise (1975–Present)**

A collection of production ephemera from the productions of Tim Hill's sci-fi comedy *Muppets from Space*, and Gary Halvorson's musical comedy *The Adventures of Elmo in Grouchland*. Included in the lot is a size "XL" bomber jacket, two scripts, a Kermit watch, an Elmo watch, and a Miss Piggy poster. The jacket features white embroidery which reads "Muppets from Space Cast and Crew 1999" on the front and green embroidery which reads "The Jim Henson Company" on the back, with an image of Kermit. The Kermit watch comes with a stand, as well as with the original box and paperwork. The Elmo watch is also contained in its original box with its original paperwork. Both feature their respective characters on the watch face, and have black leather straps. The Miss Piggy poster is from a "Pigtoria's Secret" photoshoot, and features Miss Piggy in nightwear. It is mounted to a wooden backboard. The scripts are from *The Adventures of Elmo in Grouchland* and *Muppets from Space*, respectively. Dimensions: 75 cm x 50 cm x 25 cm (29.5" x 19.75" x 10")

**Estimate: £1,000 - 2,000**



**1520**  
**Tom Burgess' (Harry Styles) Wedding Suit + My Policeman (2022)**

Tom Burgess' (Harry Styles) wedding suit from Michael Grandage's romantic drama *My Policeman*. Tom wore his navy blue suit when he got married to Marion (Emma Corrin). The suit consists of a jacket (labelled "H/S March 2021") and matching trousers. Neither item has size labelling.

**Estimate: £800 - 1,600**



**1519**  
**Miss Piggy-Autographed Glove + The Muppets Franchise (1975–Present)**

A Miss Piggy autographed glove from Jim Henson's *The Muppets* franchise. Jim Henson Productions kept a limited quantity of these gloves made for the famous Muppet in stock to donate to charity auctions. The glove is made of purple satin, and has been autographed by Miss Piggy in black ink, with the inscription "Love from your superstar". The glove is four-fingered, and exhibits some minor wear. The autographs in this lot have been professionally authenticated by expert Garry King; see notice in the Buyer's Guide.

**Estimate: £2,000 - 4,000**



**1521**  
**Mugwump Maquette m Naked Lunch (1991)**

A sitting Mugwump maquette from the semi-biographical drama *Naked Lunch*. Based on William S. Burroughs' bizarre novel, the film depicts Bill Lee (Peter Weller), a 'junkie' exterminator whose hallucinations send him on secret missions overseen by giant bugs. This maquette served as a concept model for director approval when creating the Mugwump creatures seen throughout the film. The piece is made of a sculpting compound and is painted with great detail. Dimensions: 25 cm x 26 cm x 26 cm (9.75" x 10.25" x 10.25")

**Estimate: £1,500 - 3,000**

**1523**  
**Marshal Davout's (Youssef Kerkour) Hero Sword and Scabbard + Napoleon (2023)**

Marshal Davout's (Youssef Kerkour) hero sword and scabbard from Ridley Scott's biopic *Napoleon*. One of Napoleon's most trusted military leaders, Davout carried his sword at the Battle of Austerlitz. This hero sword features a stainless steel blade and an ornate eagle pommel. The scabbard is primarily steel with brass detailing with two loops for attaching to the belt. Dimensions (sword in scabbard): 106.5 cm x 3.5 cm x 13 cm (42" x 1.5" x 5") Edged, bladed or blunt object; see notice on Blades in the Buyer's Guide.

**Estimate: £1,500 - 3,000**



**1522**  
**Empress Josephine's (Vanessa Kirby) Dress + Napoleon (2023)**

Empress Josephine's (Vanessa Kirby) dress from Ridley Scott's historical biopic *Napoleon*. Josephine wore a 19th-century dress and velvet overdress ensemble as she sat by the fireplace with Napoleon (Joaquin Phoenix) as he informed her of their need to divorce. This Academy Award-nominated film explored the dysfunctional dynamic between Napoleon and Josephine whilst showcasing the famous Emperor's military endeavours in action-packed sequences akin to those seen in Scott's previous historical epic, *Gladiator*. The dress has a lavender grey outer layer and a beige nylon underlayer, with floral designs adorning the collar.

**Estimate: £2,000 - 4,000**



**1524**  
Tsar Alexander I's (Edouard Philippot) Stunt Sword in Scabbard †  
**Napoleon (2023)**

Tsar Alexander I's (Edouard Philippot) stunt sword in scabbard from Ridley Scott's historical biopic Napoleon. Tsar Alexander wore his sword on his belt when he met with Napoleon (Joaquin Phoenix). This rubber stunt sword is cast into the scabbard. It has been hand-painted to look like gold-coloured metal, and has some minor paint wear. Dimensions: 104 cm x 3.5 cm x 14 cm (41" x 1.5" x 5.5")

**Estimate: £2,000 - 4,000**



**1525**  
Marshal Davout's (Youssef Kerkour) Coronation Costume Ω  
**Napoleon (2023)**

Marshal Davout's (Youssef Kerkour) coronation costume from Ridley Scott's historical biopic Napoleon. Davout wore his costume to the coronation of Napoleon (Joaquin Phoenix) as Emperor, and also wore the jacket and boots when he witnessed Napoleon signing his abdication. The costume comprises a long navy blue woollen coat, ornately decorated with gold-coloured embroidery; a navy blue velour cape; a velour hat with decorative feathers; a pair of knee-high black leather boots; and a pair of ornate epaulettes. The cape features an interior label from costumiers Hero Collection, and the coat and boots are both labelled "Davout". The costume is also accompanied by original production labels.

**Estimate: £4,000 - 8,000**



**1526**  
Hippolyte Charles' (Jannis Niewöhner) Costume Ω  
**Napoleon (2023)**

Hippolyte Charles' (Jannis Niewöhner) costume from Ridley Scott's historical biopic Napoleon. The lover of Empress Josephine (Vanessa Kirby), French army officer Charles wore his costume at the coronation of Napoleon (Joaquin Phoenix) as Emperor, and as he left Josephine's bedchambers while Napoleon was away at war. The costume comprises a light blue woollen jacket; a matching faux fur-lined overcoat; a red woollen waistcoat; and a pair of knee-high leather boots. Each item has an interior label from costumiers Hero Collection, and the trousers feature a handwritten label reading "Jannis". The boots are labelled as belonging to Emperor Francis I (Miles Jupp) and have been added to complete the costume.

**Estimate: £3,500 - 7,000**



**1527**  
Marshal Ney's (John Hollingworth) Costume Ω  
**Napoleon (2023)**

Marshal Ney's (John Hollingworth) costume from Ridley Scott's historical biopic Napoleon. Ney wore his costume when he witnessed Napoleon (Joaquin Phoenix) sign his abdication. The costume comprises a long navy blue woollen coat, ornately decorated with gold-coloured embroidery; a pair of knee-high black leather boots; a heavily embroidered red leather belt; a white fabric belt with gold-coloured metal tassels; and a pair of ornate epaulettes. The coat and belt feature interior labels from costumiers Hero Collection, and the coat and boots are both labelled "Ney". The costume is also accompanied by original production labels.

**Estimate: £3,000 - 6,000**



**1528**  
General Junot's (Mark Bonnar) Coronation Costume Ω  
**Napoleon (2023)**

General Junot's (Mark Bonnar) coronation costume from Ridley Scott's historical biopic Napoleon. General Junot wore his costume to the coronation of Napoleon (Joaquin Phoenix) as Emperor. The film was nominated for Best Costume Design at the 96th Academy Awards. The costume comprises a cream jacket; a green overcoat with faux fur lining; a pair of cream trousers; a green woven cummerbund; and two red leather belts - one across the chest and one around the waist - both featuring leather pouches. The jacket, overcoat and trousers all feature interior labels from costumiers Hero Collection. The costume is also accompanied by original production labels.

**Estimate: £3,000 - 6,000**



**1529**  
General Dumas' (Abubakar Salim) Coronation Jacket and Cape Ω  
**Napoleon (2023)**

General Dumas' (Abubakar Salim) coronation jacket and cape from Ridley Scott's historical biography Napoleon. General Dumas wore his jacket and cape to the coronation of Napoleon (Joaquin Phoenix) as he was crowned Emperor of the French. The film was nominated for Best Costume Design at the 96th Academy Awards. The jacket and cape are navy blue and made of wool and velour respectively. Both are ornately decorated with gold-coloured embroidery. They are accompanied by an equally embellished red leather belt. All three items have interior labels from the costumiers Hero Collection and both the jacket and belt are labelled "Dumas". All three also have their original production labels.

**Estimate: £3,000 - 6,000**



**1530**  
General Junot's (Mark Bonnar) Long Jacket and Belt  
**Napoleon (2023)**

General Junot's (Mark Bonnar) long jacket and belt from Ridley Scott's historical biopic Napoleon. Junot wore his jacket and belt as he served alongside Napoleon (Joaquin Phoenix) in Egypt. The film was nominated for Best Costume Design at the 96th Academy Awards. The navy blue jacket is primarily made of wool and is ornately decorated with gold-coloured floral embroidery. The belt is made of red leather with a brass buckle and equally ornate embroidered embellishments. Both items are accompanied by their original production labels.

**Estimate: £2,000 - 4,000**

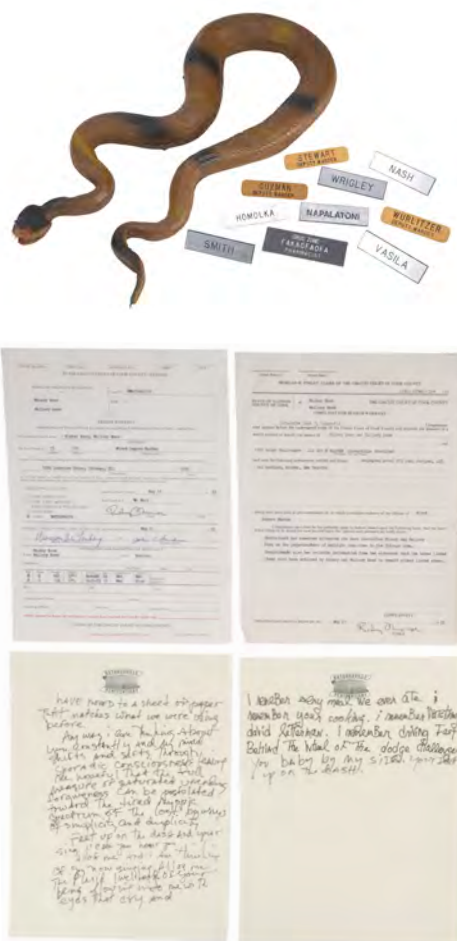

**1531**  
Mickey Knox's (Woody Harrelson) Love Letters, Arrest Warrant, Snake, and 10 Name Tags  
**Natural Born Killers (1994)**

Mickey Knox's (Woody Harrelson) love letters, an arrest warrant, a snake, and 10 name tags from Oliver Stone's Natural Born Killers. Mickey Knox wrote love letters to Mallory (Juliette Lewis) after they were both arrested; the two previously encountered many rattlesnakes after meeting (and subsequently killing) a Navajo man named Warren Red Cloud (Russell Means); and various police officers, prison staff, and a Drug Zone pharmacist Mickey shot wore name tags. This lot consists of six sheets of paper with Batongaville Penitentiary letterhead featuring excerpts of love letters handwritten in black ink; one two-page Cook County arrest warrant for Mickey and Mallory Knox; a brown and black rubber rattlesnake; and 10 name tags with the names "Vasila," "Smith," "Homolka," "Nash," "Napatatoni," "Wrigley," "Stewart Deputy Warden," "Guzman Deputy Warden," "Wurlitzer Deputy Warden," and "Drug Zone Fakaofaofa Pharmacist." The paper elements exhibit some creasing and yellowing, and the name tags exhibit scratching in the finish. Dimensions: (largest) 21.75 cm x 28 cm (8.5" x 11")

**Estimate: £2,500 - 5,000**



**1532**  
Mickey Knox's (Woody Harrelson) Bloody Shirt  
**Natural Born Killers (1994)**

Mickey Knox's (Woody Harrelson) bloody shirt from Oliver Stone's Natural Born Killers. During his interview, Knox attacked the guards as he incited a riot in the prison and became covered in blood. This lot consists of a blue linen button-up shirt (size L) with rolled sleeves and a serged button hem with white thread. Production internally distressed this shirt to appear bloodied and cut open on the back bottom hem. This shirt exhibits snagged and loose threads.

**Estimate: £1,500 - 3,000**

**1533**  
Pair of Production Artworks  
**The Neverending Story (1984)**

Production artworks from the production of Wolfgang Petersen's fantasy film The NeverEnding Story. This lot includes two original artworks, created using mixed media. Both are nighttime sceneries, one a concept piece for the Sphinx gate featured in the film, the other of a cave, both of which featured in Atreyu's (Noah Hathaway) journey to find the Southern Oracle. The illustration of the cave can be seen in the book "The World of The Neverending Story" by Michael Goerden. Dimensions: 65 cm x 31 cm (25.5" x 12.25")

**Estimate: £1,000 - 2,000**



**1534**  
Collection of Pre-Production and Post-Production Items  
**The Neverending Story (1984)**

A collection of pre-production and post-production items from the production of Wolfgang Petersen's fantasy film The Never Ending Story. Included in this lot are a collection of photos, a script, various storyboards, an amulet concept piece, and pieces from the luck dragon Falkor. The Falkor pieces are made of foam rubber, and comprise two heads and two halves of the dragon's body. They are unpainted and have no fur attached. The amulet is made of resin, and is formed into the shape of two snakes devouring one another. It comes in its original rubber mould, from which it can be removed. The photo collection comprises three A3 sheets of black card, onto which behind-the-scenes photos are adhered, with annotations in white ink, as well as loose behind-the-scenes photos. The storyboards are printed, and come with brief descriptions of each scene. The script is titled "The Never Ending Story", credited to Wolfgang Petersen, and dated "15.2.1983". The Falkor pieces show some misshapping and dryness, and along with the amulet mould exhibit some dirt from age. The amulet has minor wear, as does the script, but otherwise all the pieces remain in good condition. Dimensions: 41.5 cm x 30 cm x 10 cm (16.5" x 12" x 4")

**Estimate: £4,000 - 8,000**

**1535**  
The Devil Paint Test Maquette  
**The Nightmare Before Christmas (1993)**

A paint test maquette for the Devil character from the production of Henry Selick's The Nightmare Before Christmas. The Devil was a resident of Halloween Town, joining in with his neighbours when they broke into song. This resin maquette was created to check the aesthetic of the chosen colour palette for the character's design and to test the application of said paintwork. Dimensions: 20 cm x 11.75 cm x 35 cm (7.75" x 4.75" x 13.75")

**Estimate: £2,000 - 4,000**





**1536**  
 Reindeer Plans **M**  
**The Nightmare Before Christmas (1993)**

Reindeer plans from Henry Selick's animated musical fantasy film *The Nightmare Before Christmas*. Jack Skellington drew up plans for the creation of his reindeer as part of his ambitious plan to take over Christmas. The printed art shows the reindeer from two different angles and has been annotated. The annotations are largely illegible and the paper has been torn previously and put back together. The drawing has been reinforced, but still exhibits some fragility along fold lines, and should be handled with caution. Dimensions: 29 cm x 21 cm (11.5" x 8.25").

**Estimate: £4,000 - 8,000**

**1537**  
 Cast-Autographed One Sheet **M**  
**Nightmare On Elm Street, A (1984)**

A cast-autographed One Sheet poster from Wes Craven's horror film *A Nightmare on Elm Street*. The poster is autographed in silver ink by Heather Langenkamp and Robert Englund, who played Nancy Thompson and Freddy Krueger, respectively. The actors have written their characters' names besides their signatures. Dimensions: 101.5 cm x 68.5 cm (40" x 27") The autographs in this lot have been professionally authenticated by expert Garry King; see notice in the Buyer's Guide.

**Estimate: £500 - 1,000**



**1538**  
 "Man of Constant Sorrow" Soggy Bottom Boys  
 Vinyl Record **M**  
**O Brother, Where Art Thou? (2000)**

A "Man of Constant Sorrow" Soggy Bottom Boys records from the Coen Brothers' crime comedy *O Brother, Where Art Thou?* A spinning Soggy Bottom Boys vinyl record was double-exposed with images of the main characters during a montage. This black plastic vinyl record, labelled "MAN OF CONSTANT SORROW" by THE SOGGY BOTTOM BOYS, comes with a paper sleeve. Dimensions: 25.5 cm x 26.75 cm x 0.5 cm (10" x 10.5" x 0.25")

**Estimate: £600 - 1,200**



**1539**  
 Rusty Ryan's (Brad Pitt) Suit **M**  
**Ocean's Eleven (2001)**

Rusty Ryan's (Brad Pitt) suit from Steven Soderbergh's crime caper *Ocean's Eleven*. Rusty wore his suit when he discovered that Tess Ocean (Julia Roberts) was a factor in Danny Ocean's (George Clooney) planned casino heist. The suit comprises a navy blue double-breasted suit jacket with matching trousers, and a green shirt. The jacket is labelled "Mr Brad Pitt" in the inside right pocket and the shirt is labelled "BP March 2001" in the collar. The suit is accompanied by a certificate of authenticity from Warner Bros.

**Estimate: £2,000 - 4,000**



**1540**  
 First Release US Six Sheet Poster **M**  
**Once Upon A Time In The West (1968)**

A rare first release US Six Sheet poster for Sergio Leone's epic western *Once Upon a Time in the West*. The film tells the story of Jill McBain (Claudia Cardinale), who arrives home to her family only to find them slaughtered by the villainous Frank (played against type by Henry Fonda). Claudia Cardinale's rise to international fame after starring in Federico Fellini's *8 1/2* (1963) earned her top billing above this film's three American stars Henry Fonda, Jason Robards and Charles Bronson. This stunning large format poster features artwork by Frank McCarthy and has been conservation linen-backed with virtually no restoration. The was some handling and edge wear but that has all but disappeared during the backing process. With very white whites, the piece displays brilliantly. Dimensions (paper only): 207 cm x 196 cm (81.5" x 77")

**Estimate: £1,000 - 2,000**



**1541**  
 Agent Evan Funsch's (Jason Statham) MVA "M590" Pistol **M**  
**The One (2001)**

Agent Evan Funsch's (Jason Statham) MVA "M590" pistol from James Wong's *The One*. MultiVerse Authority (MVA) agent Funsch wielded his signature otherworldly M590 pistol while he tracked outlaw Gabriel Yulaw (Jet Li) through 124 alternate universes. This static, cast resin pistol originated from a crew member. Based on a SIG-Sauer P220 Sport, it features a curved black handgrip with an extended compensator painted to appear metallic, a ribbed front sight, and the partial serial number "6238" engraved along the barrel. In addition to paint scuffing, the gun exhibits fractures and cracks throughout from production use with adhesive residue in multiple places along its body where broken pieces were previously reattached. Dimensions: 30 cm x 16.5 cm x 4 cm (11.75" x 6.5" x 1.5") Ownership may be restricted in some countries; see replica firearm notice in Buyer's Guide.

**Estimate: £1,000 - 2,000**



**1542**  
Gabriel Yulaw's (Jet Li) Stunt Modified Heckler & Koch USP Pistol  
The One (2001)

Gabriel Yulaw's (Jet Li) stunt modified Heckler & Koch USP pistol from James Wong's The One. Interdimensional outlaw Yulaw wielded his otherworldly gun before he was captured by the MultiVerse Authority (MVA). This moulded, dense rubber stunt handgun with a rounded, extended underside to its barrel originated from a crew member. It is painted entirely black with a textured handgrip and butt and H&K logos engraved on the grip and barrel. The rubber exhibits some nicking, scratching, and flaking paint in multiple areas from production use. Dimensions: 28 cm x 14 cm x 4 cm (11" x 5.5" x 1.5") Ownership may be restricted in some countries; see replica firearm notice in Buyer's Guide.

**Estimate: £1,000 - 2,000**

**1543**  
Jake Pentecost's (John Boyega) Screen-Matched Light-Up Tracker  
Pacific Rim Uprising (2018)

Jake Pentecost's (John Boyega) screen-matched light-up tracker from Steven S. DeKnight's sci-fi sequel Pacific Rim: Uprising. This tracker screen-matches to the beginning of the film when Jake used it to find a disabled power core. This black plastic tracker with a metal frame, LCD screen, and a camera lens is battery powered. A side button toggles the tracker and features images of the junkyard, a moving red dot, and a distance range. "HGM 1013" is printed on a rear sticker. Production intentionally distressed this tracker to appear well-used. It exhibits chipped paint and discoloured metal. Dimensions: 14 cm x 7.75 cm x 5 cm (5.5" x 3" x 2") Contains electronics; see electronics notice in the Buyer's Guide.

**Estimate: £1,500 - 3,000**

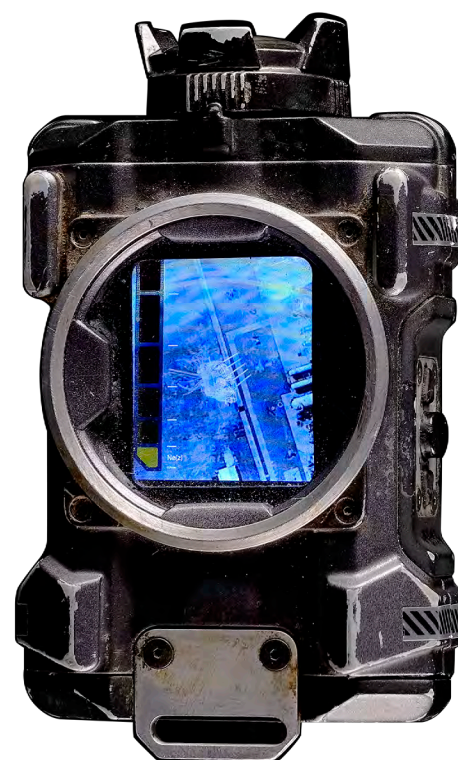

**1544**  
M2 Flamethrower  
The Pacific (T.V. Series, 2010)

An M2 flamethrower from the war drama miniseries The Pacific. Corporal Charles Womack (John Reynolds) used the M2 to flush out a bunker in part seven of the series, and then again by a nameless marine on Iwo Jima in part eight. The flamethrower is made of metal and comprises two parts: three tanks mounted onto a frame and wearable on the back, and a handheld "gun" that attaches to the tanks via a hose. The flamethrower is painted khaki green, and features fabric straps to facilitate wear on the back. At the time of filming, the flamethrower was functional. The item exhibits some paint chipping and rusting, but otherwise remains in very good condition. Dimensions: 70 cm x 55 cm x 40 cm (27.5" x 21.74" x 15.75") Restricted ownership; see replica firearm notice in the Buyer's Guide.

**Estimate: £1,000 - 2,000**



**1545**  
Phoenix Buchanan (Hugh Grant) Suit of Armour  
Paddington 2 (2017)

Phoenix Buchanan's (Hugh Grant) suit of armour, with spare parts, from Paul King's family comedy Paddington 2. Buchanan hid from security in his suit of armour before finding the first clue from the 'Pop-Up London' book: a "D" engraved into a white column on top of Tower Bridge. The costume comprises a helmet with a visor and bevor (both functional); two pauldrons; two vambraces; three cuisse-and-poleyn combined components; six greaves; two sabatons; two fingerless gauntlets; and two gorgets. Each component is made of urethane resin and painted steel-grey to look like metal. The undersides of the vambraces are lined with leather, while many of the items feature leather fastening straps with metal buckles. One of the pauldrons has "Stunt 1" handwritten in black marker pen on a label adhered to its interior, beside a handwritten "NA", which is also found on the second pauldron.

**Estimate: £3,000 - 6,000**



**1546**  
Norman (Kodi Smit-McPhee) Stop-motion Face  
Paranorman (2012)

A Norman (Kodi Smit-McPhee) stop-motion face from Chris Butler and Sam Fell's stop-motion comedy horror ParaNorman. This face depicts Norman as sad. The face was 3-D printed in resin, and its colouring was applied during the printing process, enabling consistency between the many replacement animation faces created for the character. The face is attached with magnets so that the production's animators could quickly replace it with other expressions in between shots. The interior of the face presents reference numbers that were used to keep track of the different faces during production. The face is accompanied by a wooden display box that features a laser-cut mount with movie stills. Dimensions: 54.5 cm x 30 cm x 9.5 cm (21.5" x 11.75" x 3.75")

**Estimate: £1,000 - 2,000**



**1547**  
Benjamin Martin's (Mel Gibson) Bloodied Shirt with Bound Script  
The Patriot (2000)

Benjamin Martin's (Mel Gibson) bloodied shirt with bound script from Roland Emmerich's The Patriot. After his son, Thomas' (Gregory Smith) death, Benjamin attacked the British convoy and killed the soldiers, gradually becoming more and more blood-covered. This lot consists of one beige cotton shirt and a bound script. The script consists of 203 pages with edited editions from June 18, 1999 to September 28, 1999. The script is hand-marked "Pink" on various pages in black marker. Production intentionally distressed this shirt to appear bloodied and grimy. This lot exhibits stiffness from the SFX blood and discolouration on the script, as well as creased corners and a tear on one corner. Dimensions: (script) 21.5 cm x 23 cm x 2.5 cm (8.5" x 11" x 1")

**Estimate: £2,000 - 4,000**





**1548**  
Phantom Mask M  
Phantom Of The Opera  
Stage Production

A Phantom mask from the stage production of The Phantom of the Opera. The mask is vacuum-formed plastic with a leather inner lining to ease the wearer's comfort. Two metal wires are attached to its rear to create the illusory effect of it remaining on the wearer's face despite no support.  
Dimensions: 19.5 cm x 16 cm x 22 cm (7.75" x 6.25" x 8.75")

**Estimate: £500 - 1,000**

**1549**  
Collection of Robbie Body  
and Faces M  
Pingu (T.V. Series, 1980-2006)

Robbie body parts and faces from the children's animated television show Pingu. Robbie the seal was a recurring character on the show, and a good friend of the penguin Pingu. The lot comprises a box containing 15 heads, nine bodies and a sheet of eye stickers. Each of the heads displays a different expression, and each of the bodies a different pose. The heads can be attached to the bodies. The box originally held 16 heads, but one has since been lost, and some of the remaining heads haven't had stickers applied. Otherwise, the lot remains in excellent condition. Dimensions: 43 cm x 33 cm x 22 cm (17" x 13" x 8.75")



**Estimate: £3,000 - 6,000**

**1550**  
Collection of Pingu Set Pieces M  
Pingu (T.V. Series, 1980-2006)

Set pieces from the production of the children's animated television series Pingu. Items such as these were used variously by Pingu and his friends throughout the series. Included in this lot are a scooter, a music stand, two sets of skis, six radios, a record player, two vinyls, one rocket, and one set of ski poles. Other items are made largely of resin, though one of the vinyls comes with a paper sleeve. The blue skis exhibit a missing toe piece, and the items exhibit some general paint wear, but otherwise they remain in good condition. Dimensions: 27 cm x 17 cm x 13 cm (10.75" x 6.75" x 5.25")

**Estimate: £2,000 - 4,000**



**1551**  
Mrs. Penguin M  
Pingu (T.V. Series, 1980-2006)

A Mrs. Penguin model from the children's animated television series Pingu. Mrs. Penguin, also known as Maman or Mama, was the mother of Pingu and Pinga, and a main character of the series. The model, which is made of resin, shows Mrs. Penguin fallen over on her stomach. "PU007 5R" has been carved into the underside of her right foot, and "5L" into the underside of her left. The underside of her body exhibits some minor paint wear, but otherwise she remains in excellent condition. Dimensions: 13 cm x 6 cm x 5 cm (5.25" x 2.5" x 2")

**Estimate: £2,000 - 4,000**



**1552**  
Screen-matched Bloodied Piranha  
Body Ω  
Piranha 3DD (2012)

A screen-matched bloodied piranha body from John Gulager's Piranha 3DD. After the piranhas were released into the water park and the water level lowered, Big Dave (Adrian Martinez) poured chlorine into the water park's system followed by a lit joint to create an explosion that killed most of the remaining fish. The viscera pattern, paint work, and unique "white" dimple on a side fin screen-match to the piranha that fell near a hot dog stand after the explosion. This lot consists of one silicone fish body without a head painted in various shades of yellow, red, and green, with silicone fish viscera bits. Production intentionally distressed this fish to appear bloodied as if its head had been blown off. This lot exhibits flaked paint, discolouration on one side, and missing spine tips. Dimensions: 51 cm x 25.5 cm x 12.75 cm (20" x 10" x 5")

**Estimate: £2,000 - 4,000**

**1553**  
Collection of Crew Tops and Caps M  
Pirates Of The Caribbean:  
The Curse Of The Black Pearl (2003)

A collection of crew clothing from Gore Verbinski's swashbuckler Pirates of the Caribbean films. Clothing and other items were gifted to crew members to wear during production and in appreciation of their work on the film. All of the items included in this lot feature printed or embroidered references to the films, including logos, posters or character images. Some of the caps and T-shirts exhibit minor signs of wear.

**Estimate: £300 - 600**







**1554**  
Collection of Pirate Treasure Coins m  
**Pirates Of The Caribbean:  
The Curse Of The Black Pearl (2003)**

Isla de Muerta treasure coins from Gore Verbinski's action-adventure film *Pirates of the Caribbean: The Curse of the Black Pearl*. These coin stacks were used as set dressing for the pirate cave on Isla de Muerta, where Captain Barbossa (Geoffrey Rush) hid his cursed treasure. This lot comprises 30 coins plated with a faux-gold finish and 25 faux-silver coins, all of which are made of metal and stamped with patterns resembling those used on real Spanish currency of the period. The coins exhibit some minor wear from production use, but otherwise remain in very good condition. Dimensions: 13 cm x 10 cm x 2 cm (5.25" x 4" x 0.75")

**Estimate: £3,000 - 6,000**

**1555**  
Set of Three Cursed Aztec Coin and Spanish Coins m  
**Pirates Of The Caribbean:  
The Curse Of The Black Pearl (2003)**

A cursed Aztec coin and two Spanish coins from Gore Verbinski's action-adventure film *Pirates of the Caribbean: The Curse of the Black Pearl*. Central to the film's plot, cursed Aztec coins formed the vast treasure hoard of Cortes, hidden on the Isla de Muerta, which transformed Captain Barbossa (Geoffrey Rush) and his crew into undead creatures. The coins are made from cast metal and plated with a faux-gold finish. Cursed Aztec coins and Spanish coins, as well as various other treasure, formed the vast hordes of wealth found by Barbossa (Geoffrey Rush) in the Isla de Muerta pirate cave. The cursed coin features a skull-and-sun symbol on one side, and the reverse displays an Aztec glyph. The Spanish coins feature the royal coat of arms, and "Philippus V D Grat" on one side, and a cross and "Hispaniarum Rex 1701" on the other. Also included are two letters of authenticity. The coins exhibit some production-deliberate wear, but otherwise remain in very good condition. Dimensions: 4 cm x 4 cm x 0.5 cm (1.5" x 1.5" x 0.25")

**Estimate: £3,000 - 6,000**



**1556**  
Full-Size Black Pearl Cannon USA  
**Pirates Of The Caribbean:  
The Curse Of The Black Pearl (2003)**

A full-size Black Pearl cannon from Gore Verbinski's *Pirates of the Caribbean: The Curse of the Black Pearl*. Crew of the Black Pearl used its cannons to fend off the Royal Navy and rival pirates. This style of cannon also appeared throughout the film on the fort parapet and the Royal Navy's ship. This cannon is built of wood, metal, and dense rigid foam painted gunmetal black with its wooden base finished in brown. It features eyelets and chains on the sides and clamps to hold the cannon in place. The base of the cannon has been split into two pieces down the middle. This lot exhibits scuffing, splintered wood, chipped paint, and a buildup of grime. Dimensions: 198 cm x 96.5 cm x 76.25 cm (78" x 38" x 30") Special shipping required; see notice in the Buyer's Guide.

**Estimate: £1,500 - 3,000**



**1557**  
"Lavinia" Stop-motion Figure m  
**Pirates! In An Adventure With Scientists! The, (2012)**

A "Lavinia" stop-motion figure from Peter Lord and Jeff Newitt's adventure-comedy *The Pirates! In an Adventure with Scientists!* After he was pardoned by Queen Victoria (Imelda Staunton), a group of local Londers tried to persuade The Pirate Captain (Hugh Grant) to celebrate in a pub with them. Lavinia, a lady in a yellow dress, sealed the deal when she said, "Oh, Captain, do join us, please?". Made by Aardman Animations, this figure has silicone hands, latex clothing, torso and hair, a cast resin head, and a metal armature. It is displayed on a piece of cast resin designed to look like ship debris. Dimensions: 18 cm x 18.5 cm x 28.5 cm (7" x 7.25" x 11.25") Please note: Customers completing a purchase for this artefact, hereby agree that it will not be replicated or used in any other film or television production.

**Estimate: £2,000 - 4,000**



**1558**  
Pair of Chimpanzee Boots n  
**Planet Of The Apes (1968)**

A pair of chimpanzee boots from Franklin J. Schaffner's *Planet of the Apes*. Astronaut George Taylor (Charlton Heston) encountered groups of super intelligent apes after he landed on a futuristic version of Earth. These boots are sculpted over Sears Jeepers to resemble chimpanzee feet made of army green canvas with black rubber soles marked "RODDY" and "8M" throughout. These boots exhibit fraying internal material.

**Estimate: £2,000 - 4,000**

**1559**  
Gorilla and Chimp Soldiers' Helmets n  
**Planet Of The Apes (2001)**

Gorilla and chimp soldiers' helmets from Tim Burton's sci-fi adventure *Planet of the Apes*. Astronaut Leo Davidson (Mark Wahlberg) crash-landed on a planet where various species of evolved primate soldiers controlled humans. This lot consists of two crimson urethane helmets, each with rubber accents, metal chainmail neck guards, and black cloth padding on the interior. The round gorilla helmet is hand-marked "55/8" and "57/8" on the interior, while the cone-shaped chimp helmet is hand-marked "C1" and includes a black nylon chinstrap. The pair exhibits paint chipping and separation between the neck guards and helmets from production wear.

**Estimate: £1,500 - 3,000**

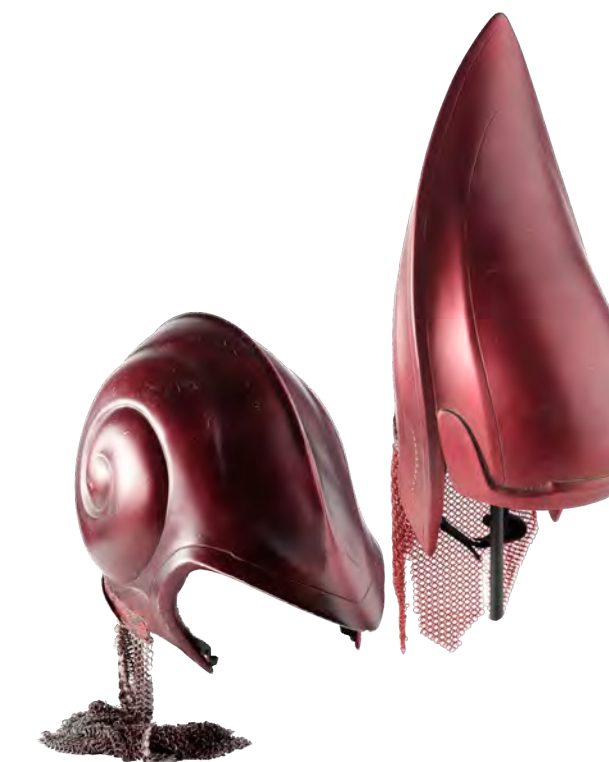



**1560**  
Gorilla Soldier Rifle  $\Omega$   
**Beneath The Planet Of The Apes**  
**(1970)**

A gorilla soldier rifle from Ted Post's Beneath the Planet of the Apes. Ape soldiers carried crude brown rifles that resembled modified M1 Carbines throughout the film. Some of the rifles were later reused in the 1974 Planet of the Apes television series. This rifle features a sculpted, solid wood body with a reddish-brown finish, a dowel added at front and painted black to resemble a barrel, a separate metal midsection bolt and sight element painted black, and two metal brackets with a black nylon shoulder strap. It exhibits various nicks, scuffs, and scratches throughout its finish from production use and handling. Dimensions: 89 cm x 12.75 cm x 4 cm (35" x 5" x 1.5") Ownership may be restricted in some countries; see replica firearm notice in Buyer's Guide.

**Estimate: £1,200 - 2,400**

**1561**  
Set of Three Santa's (Tom Hanks) Sleigh Bells  $\mu$   
**The Polar Express (2004)**

A set of three Santa's (Tom Hanks) sleigh bells from the production of Robert Zemeckis' adventure film The Polar Express. Santa's reindeer wore red-coloured harnesses decorated with rows of bells when they appeared in the North Pole Square. Only children who truly believed in Santa Claus heard the ringing of the bells, and the sound of these bells matches the jingling heard in the film. Physical props were used by live-performing actors in motion-capture suits. The actors and the props they held were then overlaid with computer-generated imagery. The three matching metal bells are decorated with ornate engraved patterns. Small patches of green paint have been applied to replicate verdigris patina. Dimensions (each): 5 cm x 4 cm x 4 cm (2" x 1.5" x 1.5")



**Estimate: £3,000 - 6,000**



**1562**  
City Hunter's (Kevin Peter Hall) Stunt Predator  
Smart Disc  $\mu$   
**Predator 2 (1990)**

The City Hunter's (Kevin Peter Hall) stunt Predator Smart Disc from Stephen Hopkins' sci-fi action sequel Predator 2. During a battle in a slaughterhouse, the City Hunter Predator cut CIA agent Peter Keyes (Gary Busey) in half with its Smart Disc. The Smart Disc was designed by Stan Winston Studio to differentiate this sequel's alien hunter from the creature in John McTiernan's Predator. Operable servo-equipped and nonmechanical static versions were manufactured for production, and this Disc is of the latter kind. The two-piece stunt Disc is constructed of dense rubber painted a copper colour, with large finger holes and greebles moulded on both pieces. Dimensions: 25.5 cm x 25.5 cm x 2.75 cm (10" x 10" x 1")

**Estimate: £2,500 - 5,000**

**1563**  
Tracker Predator's (Carey L. Jones) Back Armour  
with Animatronic Plasmacaster  $\Omega$   
**Predators (2010)**

The Tracker Predator's (Carey L. Jones) back armour with an animatronic Plasmacaster from Nimrod Antal's Predators. The Tracker, also known as the Flusher, wore his signature Yautja body armour with a super-powered Plasmacaster throughout the film as he hunted humans for sport. This plated fibreglass Yautja body armour piece is painted dark blue with brown leatherette straps and a fastening strip closure. An animatronic Plasmacaster is mounted on the shoulder and wired to a new internal electronics kit added to restore functionality to the Plasmacaster, which can move up and down and side to side via an attached controller that replaced the radio-control unit used during production. The armour exhibits scuffing throughout the finish. Dimensions: 73.75 cm x 51 cm x 30.5 cm (29" x 20" x 12") Contains electronics; see electronics notice in the Buyer's Guide.

**Estimate: £3,000 - 6,000**



**1564**  
Hanzo's (Louis Ozawa) Katana with Saya  $\Omega$   
**Predators (2010)**

Hanzo's (Louis Ozawa) katana from Nimrod Antal's Predators. Hanzo originally found the katana in Ronald Noland's (Laurence Fishburne) hideout which he took and later used to fight against the Falconer predator. This sword is made of aluminium, with an ornate brass-colour guard, a resin grip designed to resemble ivory with faux leather braided around it, and a wood saya also wrapped in faux leather with silver-colour metal bridges. Production intentionally distressed this katana to appear aged and grime-covered. This lot exhibits a buildup of grime in the fine crevices and some discolouration to the metal. Dimensions: 106.75 cm x 10.25 cm x 10.25 cm (42" x 4" x 4") Blade was dulled after production in order for it to be sold as a collectible. Edged, bladed or blunt object; see notice on Blades in the Buyer's Guide.

**Estimate: £1,500 - 3,000**



**1565**  
Elizabeth Bennet's (Keira Knightley) Purple Dress  
and Green Coat  $\pm\Delta$   
**Pride & Prejudice (2005)**

Elizabeth Bennet's (Keira Knightley) dress and coat from Joe Wright's Academy Award-nominated romantic drama Pride & Prejudice. Elizabeth wore a purple dress and green overcoat throughout the film, sometimes separately, other times as an ensemble. She wore the purple dress when she rejected Mr Collins' (Tom Hollander) marriage proposal, and the green coat when she did the same to Mr Darcy (Matthew Macfadyen) later in the film Both garments are made from wool, with the purple dress featuring a string fastener at the chest and the green coat buttons at its midsection. "MBKK" is handwritten on the inside of the purple dress, while "BPPP" is handwritten inside the green coat.

**Estimate: £3,000 - 6,000**



**1566**  
 DI Jane Tennison's (Helen Mirren)  
 Waxed Coat M  
**Prime Suspect (T.V. Series, 1991)**

Detective Inspector Jane Tennison's (Helen Mirren) waxed coat from the TV crime drama Prime Suspect. Tennison wore her black P.G. Field wax coat throughout the first three series of the show. It is size "S". The coat is accompanied by a handwritten note from Helen Mirren which reads "Sue Whitley - in memory of cold nights past - Love Helen" and a letter of authenticity from Whitley, who worked as a 2nd Assistant Director on the production.

**Estimate: £500 - 1,000**



**1567**  
 Tamina (Gemma Arterton)  
 Wedding Costume M  
**Prince Of Persia: The Sands Of Time (2010)**

Tamina's (Gemma Arterton) wedding costume from Mike Newell's fantasy action film Prince of Persia: The Sands of Time. Tamina wore her wedding costume during her aborted marriage to Prince Tus (Richard Coyle), and during her escape with Dastan (Jake Gyllenhaal). This lot consists of a tunic, a pair of trousers, and a beige robe, patterned with gold thread. Produced by Jane Law, both the trousers and tunic still feature original production labels, reading "23rd Sept 09 used for P/UP's needs cleaning" and "23rd Sept 09 worn for P/Ups make up around neckline", respectively. Both pieces are marked size "S", and have "Gemma Arterton" handwritten on interior labels. All three items exhibit minor staining, but otherwise remain in very good condition. Also included in the lot are a pair of shoes, which, while not obviously seen on screen, are labelled "Persian 3" inside. They remain in excellent condition.

**Estimate: £1,000 - 2,000**



**1568**  
 Hammerpede Creature Display 1/2  
**Prometheus (2012)**

A Hammerpede creature display from the production of Ridley Scott's sci-fi sequel Prometheus. Fifield (Sean Harris) and Millburn (Rafe Spall) found the urn room where two Hammerpede creatures were lurking. This silicone Hammerpede belonged to the production's creature makeup supervisor and special makeup effects supervisor, Neal Scanlan. The Hammerpede has been split in half so that both sides of the creature can be displayed together on the board. Dimensions: 37.5 cm x 36 cm x 1 cm (14.75" x 14.25" x 0.5")

**Estimate: £600 - 1,200**



**1569**  
 Set of Three Ampules 1/2  
**Prometheus (2012)**

A set of three "Engineer" ampules from Ridley Scott's Alien prequel Prometheus. These props were used for the scenes within the massive derelict alien spacecraft on LV-223 as Shaw (Noomi Rapace), Holloway (Logan Marshall-Green) and the crew explored the ship and discovered a huge cache of the containers surrounding a mammoth statue of an Engineer's head. Crafted by raku pottery specialist Rob Sollis, the ampules were created in a rigid self-skinning polyurethane "biscuit" foam to ensure the pieces remained strong but lightweight. Alien runes are etched vertically across the body with a bespoke metallic paint finish which has been further distressed to give an ancient, ethereal look. Showing some minor wear that reveals the cream surface beneath the paint, the ampules remain in overall very good condition. Dimensions (large ampule): 28 cm x 28 cm x 79 cm (11" x 11" x 31")

**Estimate: £3,000 - 6,000**



**1570**  
 Parameter Uplink Spectagraph  
 and Flashlight 1/2  
**Prometheus (2012)**

A Parameter Uplink Spectagraph and a flashlight from Ridley Scott's Prometheus. In 2089, archaeologist Elizabeth Shaw (Noomi Rapace) used her flashlight during her discovery of a star map in Scotland, and in 2093, Fifield (Sean Harris), the geologist of the expedition undertaken by the Prometheus, used Parameter Uplink Spectagraphs (PUPS) to map out the Engineer structure he and his companions were exploring. This lot consists of a blue-grey dense rubber sphere with a mesh texture meant to simulate metal and indented black lines running around it; and a battery-operated blue-grey metal flashlight with a button on the side. The PUPS exhibit some scuffing to its finish and the flashlight is not currently functional. Dimensions: (largest) 10.25 cm x 10.25 cm x 10.25 cm (4" x 4" x 4") Contains electronics; see electronics notice in the Buyer's Guide.

**Estimate: £1,500 - 3,000**



**1571**  
 Fossilised Engineer's Arm 1/2  
**Prometheus (2012)**

A fossilised Engineer's arm from Ridley Scott's Prometheus. The exploration crew of the Prometheus found a pile of fossilised bodies clamouring at a locked door within the bowels of the Engineer ship on LV-223. Made of biscuit foam, this single arm features an array of detailing to replicate the look of the Engineer pressure suits. Featuring only one finished side, this arm was painted in various shades of gold and brown to resemble stone as well as a grey tone to appear aged. Production intentionally distressed this arm to appear older. This lot exhibits chips, flaked paint, and exposed foam. Dimensions: 124.5 cm x 20.5 cm x 20.5 cm (49" x 8" x 8")

**Estimate: £800 - 1,600**

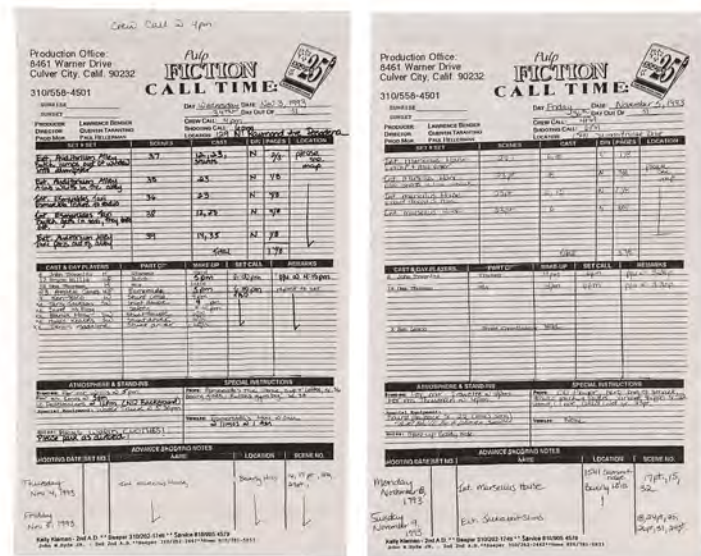

**1572**  
 Pair of Call Sheets m  
**Pulp Fiction (1994)**

A pair of call sheets from the production of Quentin Tarantino's iconic indie crime drama Pulp Fiction. The "November 3, 1993" call sheet lists a filming schedule for the sequence where Butch Coolidge (Bruce Willis) flees the arena after not taking a dive in his boxing bout. Call times are included for Willis, John Travolta (Vincent Vega), and Uma Thurman (Mia Wallace). The "November 5, 1993" call sheet is for the sequence where Vincent and Mia arrive back at Marsellus Wallace's (Ving Rhames) house. Dimensions: 35.5 cm x 21.5 cm (14" x 8.5")

**Estimate: £300 - 600**

**1573**  
 Quentin Tarantino, Samuel L. Jackson and Tim Roth-  
 Autographed Hand-numbered Variant Edition 2014  
 Screen Print by Laurent Durieux m  
**Pulp Fiction (1994)**

A limited edition alternative movie poster created by artist Laurent Durieux for Quentin Tarantino's Pulp Fiction. Durieux's unique style is instantly identifiable, with his creations numbering among the most desirable artworks in the alternative movie poster market. This design was published in 2014 by Mondo in collaboration with the Sundance Institute and the Sally Menke Fellowship. It depicts Vincent Vega (John Travolta) and Jules Winnfield (Samuel L. Jackson) entering the diner, in muted blue, orange, pink and grey colours. There are several clever additions to the artwork, including the fictional Fox Force Five television show as a billboard, and a "Big Kahuna Burger" restaurant in the background. This poster is hand-numbered 48 out of 75 and is autographed in black ink by Tarantino, Jackson and Tim Roth. The lot displays some minor edge wear in the top right corner. Dimensions: 61 cm x 91.25 cm (24" x 36") The autographs in this lot have been professionally authenticated by expert Garry King; see notice in the Buyer's Guide.

**Estimate: £2,500 - 5,000**



**1574**  
 Lady Whistledown Newspaper and Token m  
**Queen Charlotte: A Bridgerton Story (T.V. Series, 2023)**

A Lady Whistledown society paper and a gambling token from Shonda Rhimes' 2023 historical drama series Queen Charlotte: A Bridgerton Story. The Lady Whistledown society papers were widely circulated and enjoyed by high society throughout the series, and gambling tokens were used in the card games played by Queen Charlotte's (Golda Rosheuvel) children. The society paper is printed on off-white card, and the token is made of silver acrylic and features intricate carved details, including the royal crest. The token exhibits some chipping. Dimensions (society paper): 30 cm x 14 cm (12" x 5.5")

**Estimate: £600 - 1,200**



**1575**  
 Queen Elizabeth II's (Helen Mirren) Mourning Costume,  
 Final Scene Dress and Picnic Skirt +  
**The Queen (2006)**

Queen Elizabeth II's (Helen Mirren) mourning costume, final scene dress and picnic skirt from Stephen Frears' The Queen. Elizabeth wore her black dress (labelled "Helen Mirren"), black coat ("The Queen Helen Mirren") and pearls in the days following Princess Diana's death; she wore her purple dress in the final scene when she met with Tony Blair (Michael Sheen); and she wore her tartan skirt ("Helen Mirren") while picnicking in Scotland with her family. The black hat in this lot is different to the one she wears to the funeral but is labelled "The Queen Funeral Hat Helen Mirren".

**Estimate: £1,000 - 2,000**



**1576**  
 Zippy Puppet Hands m  
**Rainbow (1972-1992)**

Zippy's puppet hands from the children's television show Rainbow. Zippy was one of the primary characters on the show, a brownish-orange puppet with an oval head and a zip for a mouth. Zippy retains a cult following among those who watched the show as a child, and is overwhelmingly the most famous of the show's characters. His hands, worn by puppeteer Ronnie Le Drew, are three-fingered and made of a towelling material. Though they exhibit minor wear and dirtiness, they remain in very good condition.

**Estimate: £1,000 - 2,000**

**1577**  
 John Rambo's (Sylvester Stallone) Black Cut-Off Shirt m  
**Rambo III (1988)**

John Rambo's (Sylvester Stallone) black cut-off shirt from Peter MacDonald's Rambo III. Rambo first donned his cut-off shirt just before the attack on the village and continued to wear it until tearing it off later in the film. This lot consists of a plain black cotton shirt with the collar and sleeves torn off. It exhibits fading and staining from use and age.

**Estimate: £2,000 - 4,000**





**1578**  
IOI Loyalty Centre VR Headset and Ankle Tag  
**Ready Player One (2018)**

An IOI Loyalty Centre VR headset and ankle tag from Steven Spielberg's Ready Player One. Prisoners of the IOI Loyalty Center wore specialised VR headsets with wrist and ankle bracelets that connected them to a virtual reality of OASIS where they did the bidding of Sorrento (Ben Mendelsohn) This lot consists of a dark grey resin cast headset with a transparent black acrylic visor, metal detailing on the sides and padded rubber straps; and a light brown painted resin and rubber cuff with a "IOI" cut out on each side of the rubber and a fogged acrylic panel in the interior. This lot exhibits minor tape residue on the helmet's interior and scuffing to the cuff.

**Estimate: £3,000 - 6,000**



**1579**  
Main Cast-autographed Clapperboard  
**Red Dwarf - The Promised Land (2020)**

A production clapperboard autographed by the main cast of sci-fi sitcom Red Dwarf. This clapperboard was from the production of the 2020 feature-length special The Promised Land and has been signed by the main cast (Robert Llewellyn, Craig Charles, Danny John-Jules, Chris Barrie, Norman Lovett, Lucy Pearman and Ray Fearon), as well as the director and series co-creator Doug Naylor and cinematographer Ian Adrian. The acrylic board has a wooden clapper and the series' iconic red-and-black logo debossed on the front. Dimensions: 23.5 cm x 28 cm x 3.5 cm (9.25" x 11" x 1.5") The autographs in this lot have been professionally authenticated by expert Garry King; see notice in the Buyer's Guide.

**Estimate: £1,000 - 2,000**



**1580**  
Colin Howard Hand-drawn and Coloured "Smegazine" Cover Artwork  
**Red Dwarf (T.V. Series, 1988-2020)**

Colin Howard cover artwork for the Red Dwarf "Smegazine", the tie-in magazine for the cult comedy TV series. This artwork was hand-drawn and coloured by Howard for issue 5 of the magazine, which was published in July 1992. It features the main characters: Dave Lister (Craig Charles), Rimmer (Chris Barrie), Cat (Danny John-Jules), Kryten (Robert Llewellyn) and Holly (Hattie Hayridge). The artwork is framed above a plaque featuring a picture of the completed cover. Dimensions (frame): 67 cm x 39.5 cm x 2 cm (26.5" x 15.5" x 0.75") Sold without copyright; see copyright notice in the Buyer's Guide.

**Estimate: £500 - 1,000**

**1581**  
Pair of Milla Jovovich and Paul W. S. Anderson-Autographed Double-Barreled Stunt Pistols  
**Resident Evil: The Final Chapter (2016)**

Double-barreled stunt pistols from Paul W.S. Anderson's Resident Evil: The Final Chapter autographed by Anderson and star Milla Jovovich. Christian (William Levy) used his two skull-painted double-barreled pistols until he died, after which Alice (Jovovich) wielded them in the Hive. This lot consists of two static rubber AF2011 Dueller Prismatic pistols. They have a silver-white skull patterned skin with black textured grips. Both pistols feature Jovovich and Anderson's autographs on the barrels in white ink, most prominent at certain angles. This lot exhibits some pitting and scuffed paint. Dimensions: (each) 25.5 cm x 11.5 cm x 6.5 cm (10" x 4.5" x 2.5") Ownership may be restricted in some countries; see replica firearm notice in Buyer's Guide. Additional Provenance: Printed Letter of Authenticity from property master Kerry von Lillienfeld.

**Estimate: £2,500 - 5,000**



Milla Jovovich and Paul W. S. Anderson autograph detail



**1583**  
Frank Harper Collection: Autographed Production-Used Script and Screening Tickets with John King-written The Football Factory Script and Call Sheet  
**Rise Of The Footsoldier (2007)**

A production-used script and screening tickets from the production of Julian Gilbey's crime drama Rise of the Footsoldier, accompanied by a The Football Factory script, call sheet and screening invite, all of which have been autographed.

Frank Harper, who played criminal Jack Whomes in Rise of the Footsoldier, has autographed the relevant script and screening invites. He has also autographed the script, call sheet and screening invites for The Football Factory, in which he played Chelsea football hooligan Billy Bright. The Football Factory script is notable as it was written by novelist John King, adapted from his own book. King wrote the original script, which went into production in 2001 but shut down after a week. Nick Love was brought on as a new director and re-wrote the script, meaning this one written by King is a rarity. Dimensions: 30 cm x 21.25 cm x 0.75 cm (11.75" x 8.25" x 0.25")

The autographs in this lot have been professionally authenticated by expert Garry King; see notice in the Buyer's Guide.

**Estimate: £1,000 - 2,000**



**1582**  
Prototype Tik-Tok Backplate, Script Cover, Crew Jumper and Key Pendant  
**Return To Oz (1985)**

A prototype Tik-Tok backplate, script cover, crew jumper and a key pendant from the production of Walter Murch's dark fantasy sequel Return to Oz. Mechanical man Tik-Tok had a brass plate attached to his back with operating instructions. This prototype plate differs from the one seen in the film. The script cover is a fifth draft dated "August 3, 1983" and features an elaborate illustration of the main characters. The crew jumper is a child's size "M 10-12" in navy blue. And the pendant is a crew gift modelled after Dorothy's (Fairuza Balk) key to Oz. The script cover has some minor staining and the crew jumper seems to have shrunk over time.

**Estimate: £800 - 1,600**



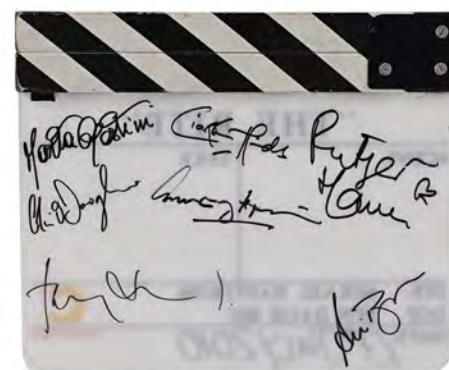

**1584**  
Cast-autographed Clapperboard m  
**The Rite (2011)**

A clapperboard autographed by the cast of Mikael Hafstrom's supernatural horror film The Rite. This clapperboard features an acrylic slate and a wooden clapper. It has the film's title along the top, and the board is dated "27th July 2010". It has been autographed by Marta Gastini (Rosaria), Ciaran Hinds (Father Xavier), Rutger Hauer (Istvan Kovak), Colin O'Donoghue (Michael Kovak), Anthony Hopkins (Father Lucas), Alice Braga (Angeline). Dimensions: 28 cm x 23.5 cm x 4.5 cm (11" x 9.25" x 1.75") The autographs in this lot have been professionally authenticated by expert Garry King; see notice in the Buyer's Guide.

**Estimate: £1,000 - 2,000**



**1586**  
EM-208 Droid Components n  
**Robocop (2014)**

A set of EM-208 droid components from Jose Padilha's reboot of RoboCop. After becoming a cyborg, police officer Alex Murphy (Joel Kinnaman) faced numerous EM-208 androids during a field test of his abilities. The lot includes a torso, a head, two upper leg sections, and two lower legs with feet. These components are made from resin, wood and vacuum-formed plastic, the latter being filled with biscuit foam to add to structural integrity. A certificate of authenticity accompanies the lot. Dimensions (torso): 75 cm x 30 cm x 35 cm (29.5" x 11.75" x 13.75")

**Estimate: £1,000 - 2,000**



**1587**  
Elton John's (Taron Egerton)  
Screen-matched Dressing Gown,  
Shirt and Slippers +  
**Rocketman (2019)**

Elton John's (Taron Egerton) screen-matched dressing gown, shirt and slippers from Dexter Fletcher's musical biopic Rocketman. John wore his dressing gown and slippers when he started singing "Your Song" at his family home and wore his flamboyant shirt while he and his wife Renate (Celinde Schoenmaker) shared an uncomfortable breakfast at home. Both the dressing gown and shirt match through their patterning. The dressing gown is size "L" and the slippers are labelled "Will". The Gianni Versace shirt is labelled "50" and has some fraying below the collar on the back.

**Estimate: £1,000 - 2,000**

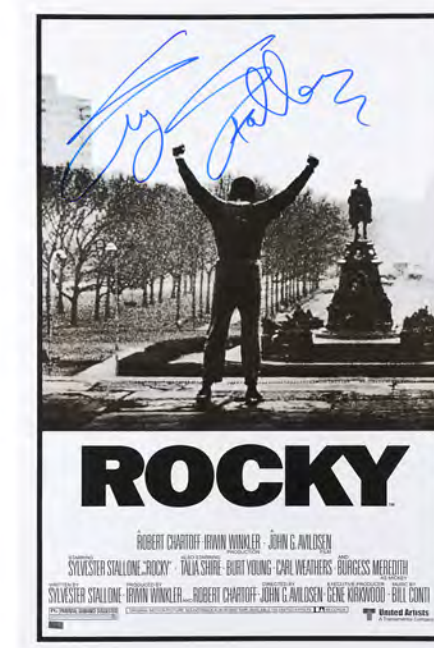

**1588**  
Sylvester Stallone-Autographed  
Commercial Poster m  
**Rocky (1976)**

A commercial poster for John G. Avildsen's boxing drama Rocky, autographed by Sylvester Stallone. The poster depicts the famous end of Rocky's training montage, where he raised his arms on the steps of the Philadelphia Museum of Art. Stallone has signed the top of the poster with his autograph in blue marker. Dimensions: 92 cm x 61 cm (36.25" x 24") The autographs in this lot have been professionally authenticated by expert Garry King; see notice in the Buyer's Guide.

**Estimate: £500 - 1,000**



**1589**  
Proposal Advertisement Poster n  
**The Rocky Horror Picture Show (1975)**

A proposal advertisement poster from Jim Sharman's The Rocky Horror Picture Show. Dr. Frank-N-Furter (Tim Curry) took in young newly engaged couple Brad Majors (Barry Bostwick) and Janet Weiss (Susan Sarandon) and included them in his extravagant party at his castle. This lot consists of a black-and-white proposal advertisement poster created by Seiniger Advertising featuring Frank, Riff Raff (Richard O'Brien) and Magenta (Patricia Quinn) printed in black-and-white. This poster is created as a collage consisting of three layered cardstock cut-outs with hand-painted touch-ups adhered to an illustration board with a cellophane cover of the 20th Century Fox film demographics. The poster is covered with a black construction paper labelled "Seiniger & Associates, Inc. Advertising." This lot exhibits tearing on the black cover, as well as notable loss of adhesion on the cut-outs. Dimensions: 43.25 cm x 61 cm x 0.75 cm (17" x 24" x 0.25")

**Estimate: £800 - 1,600**



**1585**  
Douglas Trumbull Collection: Set of Hand-Drawn Robert McCall  
Concept Artwork, Prints, Photos, and Negatives n  
**Robert McCall Artwork**

Hand-drawn concept artwork and ephemera by artist Robert McCall, an art director and concept designer for 2001: A Space Odyssey, Tora! Tora! Tora!, The Black Hole, and Star Trek: The Motion Picture, among others. This lot, from the collection of special photographic effects artist Douglas Trumbull, features seven hand-drawn mixed media concept artwork on paper with six featuring McCall's signature and marked "CITS" for "City In The Sky"; 15 colour prints and 8 colour photos in a folder marked "City In The Sky" and "CITS Art Originals transparencies, photos, and negative"; 23 colour photos and 17 negatives in a photo envelope labelled "CITS photo"; and a photo negative in black matting by Bill McLemore Photography with the label "Bob McCall." This lot exhibits loose film on the negative's matting, fold creases to the drawings, and grime throughout. Dimensions: (largest) 29.25 cm x 38.25 cm x 1.5 cm (11.5" x 15" x 0.5") Sold without copyright; see notice in the Buyer's Guide.

**Estimate: £1,200 - 2,400**



**1590**  
Stunt Mauser K98, Stunt MP40 Schmeisser,  
and Other German Military Equipment m  
**Saving Private Ryan (1998)**

A stunt Mauser K98, a stunt MP40 Schmeisser and other German military equipment from Steven Spielberg's Saving Private Ryan. Captain Miller (Tom Hanks) and his squad encountered German soldiers armed with K98s and MP40s throughout their endeavour to rescue Private Ryan (Matt Damon). Both rifles are made of hard rubber and feature a leather sling. The other military items comprise two soldier helmets, one plastic covered in a piece of camouflaged fabric and the other hard rubber, one rubber-sheathed knife, four belt buckles, a leather utility belt, one resin military badge, and one twill military badge. The lot also includes one crew gift badge, a laminated parking permit, and production paperwork such as a call sheet, shooting movement order, and map. Dimensions (Mauser K98): 106.5 cm x 12 cm x 7 cm (42" x 4.75" x 2.75") Restricted ownership; see replica firearm notice in the Buyer's Guide.

**Estimate: £1,000 - 2,000**



**1591**  
US Army Airborne Gear, Stunt M1 Garand, and  
Production Paperwork m  
**Saving Private Ryan (1998)**

A set of US Army Airborne gear, a stunt M1 Garand, and production paperwork from the production of Steven Spielberg's Saving Private Ryan. Private Ryan (Matt Damon) and his comrades wore the uniform of the Airborne division. Interestingly, "Ryan 2" has been handwritten in black ink on the underside of the military belt included in this lot. This belt's accessories include faux ammunition magazines made of wood, a metal water canteen, a rubber-sheathed knife, and a wooden and metal spade. The remaining items comprise a size "42R" US army jacket, a resin stunt M1 Garand with a leather sling strap; an assault vest containing a wooden and metal spade; a metal knife blunted for filming; two military stripes badges; pages 83 to 97 of the shooting script; and a document containing a call sheet, a shooting movement order, a map and risk assessments. Dimensions (rifle): 107 cm x 16 cm x 5.25 cm (42.25" x 6.25" x 2") Restricted ownership; see replica firearm notice in the Buyer's Guide.

**Estimate: £1,000 - 2,000**



**1592**  
Complete U.S. Rangers Uniform and Stunt M1 Garand m  
**Saving Private Ryan (1998)**

A complete U.S. Rangers uniform and a stunt M1 Garand from Steven Spielberg's Saving Private Ryan. U.S. Rangers, including Captain John H. Miller (Tom Hanks), wore battalion-specific military uniforms throughout the film. Interestingly, one of the puttees in this lot has "Miller" handwritten on its underside. As well as the puttees, the uniform is comprised of a cotton jacket marked "B67" and "47" in black ink, which features a Rangers badge; a cotton shirt with military stripes on the sleeves; a metal helmet; a nylon utility belt containing a metal drinking canteen, a leather holster and a metal and wooden shovel; a pair of leather boots; cotton trousers; and an M1 Garand stunt rifle made of hard rubber with a metal armature. The helmet exhibits rusting on its top, and the puttees exhibit rust staining. Dimensions (rifle): 110 cm x 6.25 cm x 17 cm (43.25" x 2.5" x 6.75") Restricted ownership; see replica firearm notice in the Buyer's Guide.

**Estimate: £2,000 - 4,000**

**1593**  
Timothy Thomas' (Will Smith) Hand-Annotated Notebook  
and Wallet with Production-made IDs m  
**Seven Pounds (2008)**

Timothy Thomas' (Will Smith) hand-annotated notebook and wallet with IDs from the production of Gabriele Muccino's Seven Pounds. Thomas kept extensive notes detailing his plan to save the lives of seven good people, including his brother, Ben (Michael Ealy), an IRS employee he impersonated. This lot consists of a black vinyl-bound notebook containing notes regarding organ donation, blood type, and transfusion procedures handwritten in ink throughout, as well as printed graphs taped to several interior pages; a black leather wallet containing various business cards and a production-made California driver's licence labelled "Timothy Thomas" with a picture of Thomas and biographical details printed throughout; and two production-made U.S. Treasury Department IDs labelled "Ben Thomas" and set into matching black leather wallets, one of which also contains a picture of Thomas. The notebook exhibits bent and discoloured pages from age and production. Dimensions: (largest) 24.25 cm x 18 cm x 5 cm (9.5" x 7" x 2")

**Estimate: £800 - 1,600**



**1594**  
Carrie's (Sarah Jessica Parker) Bed, Bedding and Answerphone m  
**Sex And The City (T.V. Series, 1998-2004)**

Carrie's (Sarah Jessica Parker) bed, bedding, answer phone and books from the sitcom Sex and the City. Carrie kept her answerphone and collection of books on a shelf beside her bed in her New York apartment through the earlier series of the show. This lot, originally donated to a 2004 ACLU auction by Parker herself, who was on the ACLU Directors' Board at the time, includes a queen size bedframe and mattress, two pillows, a duvet, a duvet cover, blue and white sheets and pillow covers, a blue knitted blanket, an answer phone, and four books. The duvet cover features a blue floral design, and the mattress also bears a floral design. Two of the sheets have been autographed by Sarah Jessica Parker, and she has appended the autographs with hand-drawn hearts. The answerphone has a sticker on the bottom which reads "Carrie", and comes with its electrical cords, as well as a tape still in the cassette slot, though the electronics are untested. The four books are: Andy Warhol's Diaries, Kinsey Photographer, Sex and the City: Kiss and Tell, and William Klein's New York. Parker has autographed the copy of Andy Warhol's Diaries. Some of the bedding exhibits minor discolouration and staining, and the bedframe also exhibits staining. The answerphone shows some minor wear. Dimensions: 200 cm x 160 cm x 40 cm (78.75" x 63" x 15.75") The autographs in this lot have been professionally authenticated by expert Garry King; see notice in the Buyer's Guide. Contains electronics; see electronics notice in the Buyer's Guide.

**Estimate: £2,000 - 4,000**

**1595**  
Watson's (Jude Law) Walking Stick, Cattle Prod,  
Club, and Frying Pan m  
**Sherlock Holmes (2009)**

Watson's (Jude Law) walking stick, plus a cattle prod, frying pan and club from Guy Ritchie's action adventure Sherlock Holmes. Watson used his walking stick in various fights against Lord Blackwood's (Mark Strong) men, while Sherlock Holmes (Robert Downey Jr.) used the cattle prod and club. The frying pan is not obviously seen on screen. All the items are made of rubber, and the stick, club and cattle prod have solid cores. The walking stick is embellished with white details around the handle, and is otherwise painted black. The cattle prod is painted to look metallic, has resin features, and contains a clear section at the top of the handle which looks to contain a copper coil. It is missing one of the rounded ends of its prongs. The club is painted to appear wooden. The pan is painted black, and printed with SKK branding. Each item exhibits minor wear and cracking in the paint, but otherwise remains in good condition. Dimensions: 90 cm x 30 cm x 8 cm (35.5" x 12" x 3.25")

**Estimate: £2,000 - 4,000**



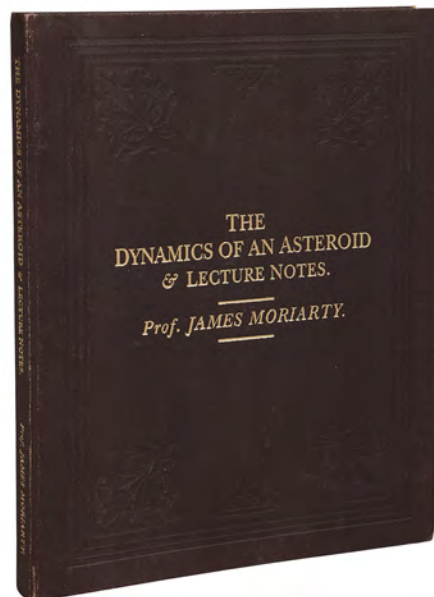

**1596**  
Moriarty's (Jared Harris) Book M  
**Sherlock Holmes: A Game Of Shadows (2011)**

Moriarty's (Jared Harris) book from Guy Ritchie's mystery action sequel Sherlock Holmes: A Game of Shadows. Sherlock Holmes (Robert Downey Jr.) got Moriarty to sign a copy of his book for him, as Moriarty taunts him about the murder of Irene Adler (Rachel McAdams). The book is bound in brown canvas with embossing at the corners, and the title is printed on the cover in gold. It reads "The Dynamics of an Asteroid and Lecture Notes Prof. James Moriarty". The book is populated with text up to the contents page, after which all pages are blank, and on the second page Moriarty's signature is printed in the top left corner. The book features minimal wear at the edges of the covers. Dimensions: 23 cm x 19 cm x 1.5 cm (9" x 7.5" x 0.5")

**Estimate: £1,000 - 2,000**



**1598**  
Deloris' (Whoopi Goldberg) Habit  
Costume Components Ω  
**Sister Act 2: Back In The Habit (1993)**

Deloris' (Whoopi Goldberg) habit costume components from Bill Duke's Sister Act 2: Back in the Habit. After she agreed to help turn the school around, Deloris resumed her identity as Sister Mary Clarence and donned her nun habit as she worked at the school. This lot consists of a black wool tunic with long sleeves and a back zip closure; a black wool scapular with button closure on one side and black piping along the edges. A wooden bead rosary with a wooden and metal crucifix were added to complete the costume. This lot exhibits frayed fibres and scuffing to the metal.

**Estimate: £1,200 - 2,400**



**1597**  
Bughuul (Nicholas King) Hero Mask and Wig Appliance M  
**Sinister 2 (2015)**

A Bughuul (Nicholas King) hero mask and wig appliance from Ciarán Foy's horror sequel Sinister 2. Bughuul was a pagan deity who possessed little children, making them kill their families and film the act. The mask is a hero version that has been fixed to a lifecast for display purposes. It is made of foam latex, on which dark, lifeless eyes and pale, mottled flesh are hand-painted. The long wig is made of jet black synthetic hair. Dimensions: 20 cm x 47 cm x 38 cm (8" x 18.5" x 15")

**Estimate: £2,000 - 4,000**

**1599**  
Headless Horseman (Christopher Walken) Crew Gift  
Statue and Framed Concept Print M  
**Sleepy Hollow (1999)**

A Headless Horseman (Christopher Walken) crew gift statue and framed concept print from the production of Tim Burton's fantasy horror Sleepy Hollow. The Headless Horseman tormented the town of Sleepy Hollow. This resin statue of the character was gifted to a member of the production crew, just like the concept print of the windmill, a significant location in the film. This print is displayed in a wooden frame. The horse's tail is slightly loose. Dimensions: 47 cm x 20 cm x 45 cm (18.5" x 7.75" x 17.75")

**Estimate: £1,000 - 2,000**



**1600**  
Brom Van Brunt's (Casper Van Dien) Stunt Knife Ω  
**Sleepy Hollow (1999)**

Brom Van Brunt's (Casper Van Dien) stunt knife from Tim Burton's Sleepy Hollow. Van Brunt threw his knife into the back of the Headless Horseman, who immediately pulled it out and threw it back into Van Brunt's leg. This knife is made of resin and rubber, and features a silver-colour blade with a brown faux-horn handle. It exhibits some scuffing and chipping, most notably to the tip of the blade. Dimensions: 37.5 cm x 5.5 cm x 3.25 cm (14.75" x 2.25" x 1.25")

**Estimate: £2,500 - 5,000**

**1601**  
Animation Cel †Δ  
**The Snowman (1982)**

An animation cel from Dianne Jackson and Jimmy T. Murakami's animated adaptation of Raymond Briggs' children's book The Snowman. This cel depicts the young boy James holding hands with the Snowman. It is drawn in colour pencil, with a layer of paint. It has been placed on a print of the winter forest from the film and displayed in a custom-made frame. Dimensions (frame): 45 cm x 45 cm x 2 cm (17.75" x 17.75" x 0.75")

**Estimate: £600 - 1,200**







**1602**  
Set of Call Sheets and  
Production-used Script M  
**Son Of Dracula (1974)**

A set of call sheets and a production-used script from the production of Freddie Francis' Hammer horror film Son of Dracula. The script is titled "Count Downe", the working title for the film, credited to Jay Fairbank and dated "1972", with revisions dated 22nd July 1972, 28th July 1972, and 4th August 1972. Also included are a set of call sheets, breakdowns, schedules, unit lists and cast lists. The items exhibit some dog-earing and discolouration, but otherwise remain in good condition. Dimensions: 35 cm x 23 cm x 4 cm (13.75" x 9" x 1.5")

**Estimate: £500 - 1,000**



**1603**  
Soo Puppet M  
**The Sooty Show (T.V. Series,  
1955-1992)**

A Soo puppet from the classic British children's television show The Sooty Show. Soo, one of the three main characters alongside her friends Sooty and Sweep, was a glove puppet panda and often the voice of reason. This puppet originated from the collection of Production Designer Stuart McCarthy, who was gifted the puppet by presenter and puppeteer Matthew Corbett. The puppet displays some minor staining to the faux fur and red fabric. Dimensions: 44.5 cm x 18.5 cm x 9 cm (17.5" x 7.25" x 3.5")

**Estimate: £500 - 1,000**



**1604**  
Tony Soprano's (James Gandolfini)  
Costume M  
**The Sopranos (T.V. Series,  
1999-2007)**

Tony Soprano's (James Gandolfini) costume from HBO's landmark gangster drama series The Sopranos. This costume featured in a Season 6 promotional still and in the Season 6 episode "Stage 5", when Tony sat at his dinner table and discussed attending the premier of the Mafia-oriented horror film Cleaver. The trousers featured in several episodes, including the series finale "Made In America".

The costume comes from Gandolfini's personal collection and is accompanied by a certificate of authenticity which he has signed. It comprises a Nat Nast size "2XT" short-sleeved shirt and a pair of grey Hart Schaffner Marx trousers. The silk bowling-style shirt has a solid red collar with ivory, red and pastel-green stripes, each stripe exhibiting decorative shirring. An internal paper label attached by a metal pin has "Tony" handwritten on it in yellow ink. The trousers have a pleated front, a zip, turn-ups, and a button and hook-and-bar closure.

**Estimate: £2,000 - 4,000**



**1605**  
Light-up "The Power" Hero  
Luxorian Ice Power Source M  
**Space Precinct - The Power (1995)**

A light-up hero Luxorian Ice power source from "The Power," the ninth episode of Gerry Anderson's sci-fi police procedural TV series Space Precinct. Luxorian Ice was a new, cheap and eco-friendly power source that created energy through magic crystals. At the climax of the episode, the crystal power source ran out of control and had to be stopped by Lieutenant Brogan (Ted Shackelford).

The Luxorian Ice is made of a translucent resin, made to look like crystal, and opaque resin made to look like rock. A switch on the bottom of the item activates the lights, which are in working condition. The lot comes with a stand. Dimensions: 60 cm x 40 cm x 40 cm (23.75" x 15.75" x 15.75") Contains electronics; see electronics notice in the Buyer's Guide.

**Estimate: £2,000 - 4,000**



**1606**  
Crixus' (Manu Bennett)  
Battle Costume Display tΔ  
**Spartacus: Blood And Sand (2010)**

Crixus' (Manu Bennett) Battle costume from the Starz historical series Spartacus: Blood and Sand. The "Undefeated Gaul" wore his attire during his battles in the arena, notably when he and Spartacus (Andy Whitfield) fought Theokoles (Reuben De Jong) in the episode "Shadow Games". The costume comprises a gold-coloured fibreglass helmet featuring a brown plume; a chain-mail manica with embellished red leather straps (labelled "Crixus", with the word "Double" crossed out); an additional leather shoulder strap; an Aztec-print fabric sash; a cotton gauntlet; a red leather belt with metal details (labelled "Crixus Hero"); a pair of burnt-orange cotton pads; and a pair of ornate, bronze-coloured fibreglass greaves. Exhibiting intentional distressing, the costume is presented on a custom-made display featuring the series' title artwork, which illuminates via a switch at the back of the base. The lot is accompanied by five Starz certificates of authenticity. Dimensions (displayed): 50 cm x 56 cm x 229 cm (19.75" x 22" x 90.25") Contains electronics; see electronics notice in the Buyer's Guide. Special shipping required; see special shipping notice in the Buyer's Guide.

**Estimate: £3,000 - 6,000**

**1607**  
Spartacus' (Andy Whitfield)  
Stunt Sword Ω  
**Spartacus - Blood and Sand (2010)**

Spartacus' (Andy Whitfield) stunt sword from the television series Spartacus. Roman-trained gladiator Spartacus wielded his sword in arena combat throughout Season 1, which was subtitled "Blood and Sand." This lot consists of a weighted dense-rubber sword with a finish simulating distressed metal with silver-colour painted nicks and textured grime added, and a leather-wrapped handle. It exhibits some scuffing from use. Dimensions: 71.25 cm x 10.25 cm x 6.5 cm (28" x 4" x 2.5")

**Estimate: £2,500 - 5,000**



**1608**  
Crixus' (Manu Bennett) Necklace M  
**Spartacus: Vengeance (2012)**

Crixus' (Manu Bennett) necklace from the historical drama television series *Spartacus: Vengeance*. Crixus wore his necklace throughout the series. It is made of leather, metal and resin, and features two layers, tied together by leather strings. It is decorated with various metal beads, including two in the shape of eagle heads, which function as the clasp of one of the layers. Coloured, frayed thread hangs from the other clasp, along with a decorative metallic pendant.

**Estimate: £500 - 1,000**



**1609**  
Officer Jack Traven's (Keanu Reeves) Jacket M  
**Speed (1994)**

Officer Jack Traven's (Keanu Reeves) jacket from *Jan de Bont's Speed*. Traven wore his jacket while getting coffee and witnessing a bus explosion, and later, onboard another bus, took it off to help wounded driver Sam Silver (Hawthorne James). This zip-up jacket (Size Large) is made of wool with a blue and brown tartan pattern by Quicksilver Salt-Water Denim. It exhibits pilling on the wool.

**Estimate: £1,200 - 2,400**

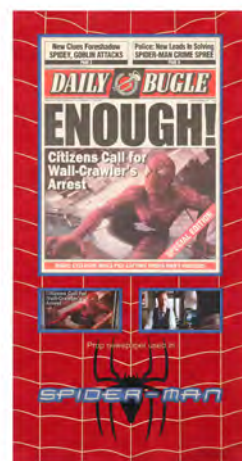

**1610**  
Set of Three Daily Bugle Newspapers M  
**Spider-Man (2002)**

A set of three *Daily Bugle* newspapers from Sam Raimi's 2002 superhero film *Spider-Man*. The *Daily Bugle* – the newspaper for whom Peter Parker (Tobey Maguire) works as a photographer – frequently published stories on the masked vigilante Spider-Man. Three headlines are featured in the collection: "Big Apple Dreads Spider Bite", "Enough! Citizens Call for Wall-Crawlers Arrest", and "Spider-Man Green Goblin Terrorize Bugle". Each paper comes mounted on a custom-made display, which includes images of the scenes in which the newspapers appear in the film, as well as the scenes the headlines describe. Dimensions: 77 cm x 43 cm x 8 cm (30.5" x 17" x 3.25")

**Estimate: £1,000 - 2,000**



**1611**  
Pair of Daily Bugle Newspaper Covers M  
**Spider-Man (2002)**

Two *Daily Bugle* newspaper covers from Sam Raimi's *Spider-Man*. After he embraced the mantle of Spider-Man, a despondent Peter Parker (Tobey Maguire) saw *Daily Bugle* papers in the newspaper's offices and on Harry Osborne's (James Franco) desk that urged the superhero's capture. These production-made, colour-printed *Daily Bugle* news stock covers are headlined "Police Seek Spider-Man! Citywide Search for the Bug" and "Spider-Man: Super-Hero or Super-Zero" alongside pictures of Spider-Man and filler text in the upper margins. Both exhibit vertical fold lines, discolouration, and edge wear from production. Dimensions: (each) 29.25 cm x 38.25 cm (11.5" x 15")

**Estimate: £1,200 - 2,400**



**1612**  
Pair of Spider-Man (Tobey Maguire) Spidersuit Chest Emblems M  
**Spider-Man 3 (2007)**

Two Spider-Man (Tobey Maguire) spidersuit chest emblems from Sam Raimi's superhero sequel *Spider-Man 3*. Spider-Man wore his iconic red-and-blue costume with a black spider emblem for the first and third acts of the film as he fought against Venom (Topher Grace) and Sandman (Thomas Haden Church). Three-time Academy Award®-winner James Acheson designed the complete costume. These two rubber spider emblems were produced in case they were required to be fitted to the middle of the costume's chest during filming. Dimensions: (largest emblem) 20 cm x 13 cm (7.75" x 5")

**Estimate: £1,000 - 2,000**



**1613**  
New Green Goblin's (James Franco) Mask M  
**Spider-Man 3 (2007)**

New Green Goblin's (James Franco) mask from Sam Raimi's superhero sequel *Spider-Man 3*. New Goblin took over the mantle from his father Norman Osborn (Willem Defoe), the villain of the first film in the trilogy, and wore his mask as he fought against Spider-Man (Tobey Maguire). The rubber mask covers the eyes and the mouth and is painted green with a carbon fibre effect. It fastens at the back of the mask with magnets, Velcro and clips. The inside of the mask has "22A" and "Lab Table" handwritten in black ink. Dimensions: 22 cm x 18 cm x 16 cm (8.75" x 7" x 6.25")

**Estimate: £4,000 - 8,000**



**1613A**  
Max Dillon's (as played by Jamie Foxx) Oscorp Jacket and Shirt  
**The Amazing Spider-Man 2 (2014)**

Max Dillon's (as played by Jamie Foxx) Oscorp jacket and shirt from Marc Webb's *The Amazing Spider-Man 2*. Max wore his Oscorp jacket and shirt when he accidentally fell into a tank of genetically engineered electric eels, consequently mutating into a living electric generator.

This lot consists of one blue canvas zip-up jacket from Dickies (Size L) with an Oscorp patch on the arm, and a button-up khaki cotton Oscorp shirt from Dickies (Size L). This lot exhibits some discolouration on the shirt, as well as snagged threads around the seams.

**Estimate: £800 - 1,600**



**1613B**  
Electro's (as played by Jamie Foxx) Distressed Street Costume  
**The Amazing Spider-Man 2 (2014)**

Electro's (as played by Jamie Foxx) distressed street costume from Marc Webb's *The Amazing Spider-Man 2*. After he awoke in the morgue, Electro put on street clothes he grabbed from the garbage.

This costume consists of a zip-up black cotton jacket, a pair of blue jeans, and a pair of black and grey trainers from Cross Trekkers. The interior of the jacket's hood features strips of LEDs with wire leads down the back. Production intentionally distressed this costume to appear grimy and covered in holes. This costume exhibits flaked vinyl on the shoes, creasing on the toe box, and frayed clothing fibres.

Contains electronics; see electronics notice in the Buyer's Guide.

**Estimate: £800 - 1,600**



**1613C**  
Gwen Stacy's (as played by Emma Stone) Costume  
**The Amazing Spider-Man 2 (2014)**

Gwen Stacy's (as played by Emma Stone) costume from Marc Webb's *The Amazing Spider-Man 2*. Stacy wore her costume while at her graduation dinner with her family before Peter Parker (Andrew Garfield) showed up to talk to her outside.

This costume consists of a pastel yellow wool trench coat lined in satin; a pastel yellow and white sweater from Prada; a white chiffon blouse with a Peter Pan collar from Comptoir des Cottonniers; a white and yellow-flowered silk skirt, and a pair of brown high-heeled shoes with T-straps from Ferragamo. This costume exhibits discolouration on the leather, snagged threads on the shirt, and minor pilling on the trench coat.

**Estimate: £800 - 1,600**



**1613D**  
Dr. Curt Connors' (as played by Rhys Ifans) Distressed Lab Coat  
**The Amazing Spider-Man (2012)**

Dr. Curt Connors' (as played by Rhys Ifans) distressed lab coat from Marc Webb's *The Amazing Spider-Man*. Connors' white Oscorp Industries lab coat became increasingly damaged and stained as he transformed into The Lizard while experimenting with DNA in New York's sewers.

This white cotton lab coat with "Oscorp Industries" printed in black on the lapel features three pockets and a rolled right sleeve. It exhibits intentional distressing by production to appear damaged with tears, grime, and fraying fabric.

**Estimate: £800 - 1,600**



**1614**  
Tom Bishop's (Brad Pitt) Costume m  
**Spy Game (2001)**

Tom Bishop's (Brad Pitt) costume from Tony Scott's espionage thriller *Spy Game*. Tom wore his costume while being taught spycraft by his mentor, Nathan Muir (Robert Redford). The costume comprises a blue woollen Helmut Lang jumper (size "L") and a pair of grey-green tartan-patterned trousers.

**Estimate: £1,000 - 2,000**

**1615**  
Oliver Hardy's (John C. Reilly) Long Coat, Shirt and Waistcoat  
and Stan Laurel's (Steve Coogan) Suit Costumes †  
**Stan & Ollie (2018)**

Oliver Hardy's (John C. Reilly) and Stan Laurel's (Steve Coogan) suit costumes from Jon S. Baird's biographical comedy-drama film *Stan & Ollie*. Laurel and Hardy wore their costumes throughout their tour of Britain and Ireland, their final tour together. Included in this lot is a blue three-piece suit, a grey plaid patterned suit, a yellow waistcoat, two white shirts (one of which is collarless), one blue shirt, and two coats - one black and one khaki. A number of the pieces feature internal labels from production: "Her Maj" and "1. Stan" in the blue trousers, "John C Reilly March 2017 1939" in the black coat, "John C Reilly March 2017 1939 Stan & Ollie" in the yellow waistcoat, and "John C Reilly March 2017" in the grey trousers. A number of the items also come with "Angels" costumiers labels. Included in the pocket of the black coat is a bag of spare buttons.

**Estimate: £1,500 - 3,000**



**1615a**  
Leonard Nimoy Collection: Matt Groening and Leonard  
Nimoy-Autographed The Simpsons Animation Cel  
**The Simpsons (1989) - Marge vs The Monorail (1993)**

An animation cel from Matt Groening's *The Simpsons* autographed by Groening and Leonard Nimoy. Nimoy guest starred on two episodes of the long-running animated comedy: Season 4's "Marge vs. The Monorail" and Season 8's "The Springfield Files," both of which are often ranked amongst the greatest episodes of the series.

This framed and matted cel, from Leonard Nimoy's personal collection, comes from "Marge vs. The Monorail" and is hand-painted onto an acetate sheet over a photocopied background of the monorail. It features a hand-drawn Bart in the lower left corner with personal inscription from Matt Groening in black ink. Additionally it features Nimoy's autograph on the white matte in blue ink. This lot exhibits minor discoloration on the matte, as well as scuffing and residue on the frame. Dimensions: 51.5 cm x 41.25 cm x 3.25 cm (20.25" x 16.25" x 1.25")

Proceeds from this lot, curated by Julie Nimoy, daughter of Leonard Nimoy, and her husband David Knight, will go towards the creation of the Leonard Nimoy LLAP Memorial sculpture at the Museum of Science in Boston, and towards supporting COPD research being conducted by Dr. John Belperio and his team at UCLA Medical Center.

Additional Provenance: A Certificate of Authenticity from Julie Nimoy.  
Sold without copyright; see notice in the Buyer's Guide.

**Estimate: £1,000 - 2,000**

**1615b**  
Leonard Nimoy Collection: Leonard Nimoy-  
Autographed Alien Voices Tape Sets and Photographs  
**Leonard Nimoy**

Alien Voices tape sets and photographs autographed by Leonard Nimoy. John de Lancie and Leonard Nimoy partnered to create a series of radio play productions of classic science fiction novels for Simon & Schuster Audio, often bringing in fellow *Star Trek* performers to provide additional voices.

This lot, from Leonard Nimoy's personal collection, consists of one sepia-tone headshot of Nimoy circa the mid-1970s, autographed by Nimoy in black ink; one black-and-white photograph of Nimoy in full costume and makeup with his 1964 Buick Riviera on the studio lot, autographed by Nimoy in silver ink; two Alien Voices audio tape sets (Jules Verne's *Journey to the Center of the Earth* and Sir Arthur Conan Doyle's *The Lost World*) autographed by Nimoy and John de Lancie; and one Alien Voices audio tape set (H.G. Wells' *The Invisible Man*) autographed solely by Nimoy. The Dimensions: (largest) 25.5 cm x 20.5 cm x 2.75 cm (10" x 8" x 1")

Proceeds from this lot, curated by Julie Nimoy, daughter of Leonard Nimoy, and her husband David Knight, will go towards the creation of the Leonard Nimoy LLAP Memorial sculpture at the Museum of Science in Boston, and towards supporting COPD research being conducted by Dr. John Belperio and his team at UCLA Medical Center.

Additional Provenance: A Certificate of Authenticity from Julie Nimoy.  
Contains mechanical components; see notice in the Buyer's Guide.

**Estimate: £1,000 - 2,000**



**1615c**  
Leonard Nimoy Collection: Collection of Leonard  
Nimoy's Personal Paraphernalia and Books  
**Leonard Nimoy**

Paraphernalia and books from Leonard Nimoy's personal collection. Throughout his career, Nimoy collected a multitude of treasures from both his *Star Trek* work and his other projects.

This lot, from Leonard Nimoy's personal collection, consists of one Alien Voices audio tape set (Jules Verne's *Journey to the Center of the Earth*) autographed by Leonard Nimoy and John de Lancie; 10 additional Alien Voices audio tape sets, one electronic "The Needs of the Many" Hallmark keepsake ornament; one boxed set of "Mr. Spock's Time Trek" *Star Trek: The Animated Series* talking Viewmaster reels; one U.S.S. Enterprise bobble ship; one *Star Trek III: The Search for Spock* soundtrack LP record; one Spock collector's cup (in its original box) from Burger King's promotion of the 2009 *Star Trek* film; five sets of ShopLLAP coasters; one pair of Spock socks by Threadless; one set of *Star Trek II: The Wrath of Khan* playing cards; one Mr. Spock Logic & Prosperity Box by Chronicle Books; one copy of *The Star Trek Compendium* by Allan Asherman; three colour-printed photograph of Nimoy as Spock; one colour-printed photograph of Nimoy and his *Star Trek* co-stars at a red carpet event; one black-and-white print of Nimoy's piece "Hand in Vulcan Gesture" from his 1998 "Hands" series with Nimoy's hand-written signature in silver on the bottom-right corner; one copy of Nimoy's book *A Lifetime of Love*; eleven copies of Nimoy's book *Warmed by Love*; and thirteen copies of Nimoy's *You and I* book. Signs of age and handling are present throughout the lot, including corner wear on boxes and tears in plastic wrappings. Dimensions: (largest) 38.25 cm x 38.25 cm x 15.25 cm (15" x 15" x 6")

Proceeds from this lot, curated by Julie Nimoy, daughter of Leonard Nimoy, and her husband David Knight, will go towards the creation of the Leonard Nimoy LLAP Memorial sculpture at the Museum of Science in Boston, and towards supporting COPD research being conducted by Dr. John Belperio and his team at UCLA Medical Center.

Additional Provenance: A Certificate of Authenticity from Julie Nimoy.

Contains electronic and mechanical components; see notice in the Buyer's Guide.

**Estimate: £1,000 - 2,000**

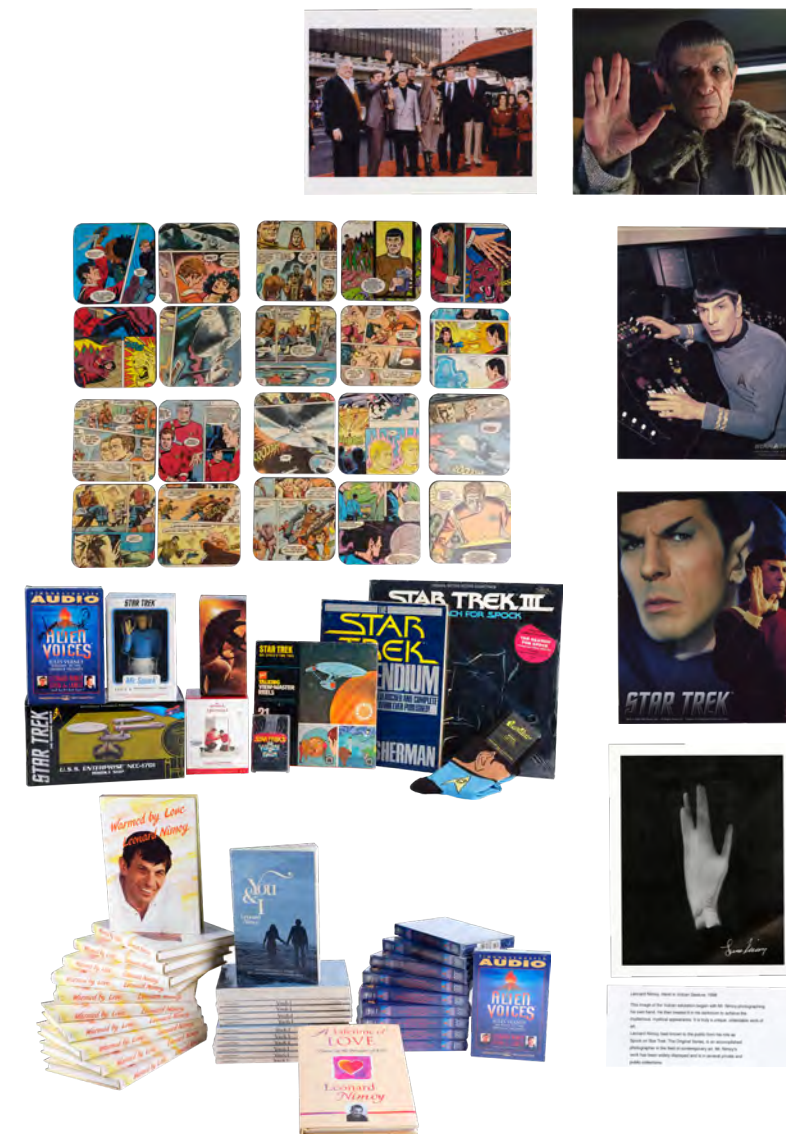



**1615d**  
**Leonard Nimoy Collection:**  
**Canadian Star Trek Stamp**  
**Collection and Spock (Leonard**  
**Nimoy) Stamp Prints**  
**Leonard Nimoy**

A collection of stamps from Canada's Star Trek stamp series with prints of the Spock (Leonard Nimoy) stamp. From 2016 through 2017, a series of 16 stamps celebrating the 50th anniversary of the Star Trek franchise were released in Canada, with the nine stamps featuring imagery from the original 1966 series released on May 5, 2016.

This collectible box set, from the personal collection of Leonard Nimoy's daughter Julie Nimoy, features the Enterprise and the 50th anniversary logo on the cover and contains those first nine stamps, including the five stamps of Captain James T. Kirk (William Shatner), Commander Spock (Leonard Nimoy), Dr. Leonard "Bones" McCoy (DeForest Kelley), Lt. Cmdr. Montgomery "Scotty" Scott (James Doohan), and Commander Kor (John Colicos); an animated lenticular sheet of the transporter and Guardian of Forever stamps, a coil dispenser with the stamps of the Enterprise and Klingon Battle Cruiser; and a glossy booklet of facts and imagery. Also included are 200 large-scale colour prints of the Spock stamp. The box exhibits some corner wear and the prints exhibit some slight bending.

Dimensions: (largest) 42 cm x 31.75 cm x 10.25 cm (16.5" x 12.5" x 4")

Proceeds from this lot, curated by Julie Nimoy, daughter of Leonard Nimoy, and her husband David Knight, will go towards the creation of the Leonard Nimoy LLAP Memorial sculpture at the Museum of Science in Boston, and towards supporting COPD research being conducted by Dr. John Belperio and his team at UCLA Medical Center.

Additional Provenance: A Certificate of Authenticity from Julie Nimoy.

**Estimate: £1,000 - 2,000**



**1617**  
**Janice Rand's (Grace Lee Whitney)**  
**Production-made Starfleet Uniform**  $\Omega$   
**Star Trek:**  
**The Motion Picture (1979)**

Janice Rand's (Grace Lee Whitney) production-made Starfleet uniform from Robert Wise's Star Trek: The Motion Picture. Rand wore her Starfleet uniform while she performed her duty as transporter chief aboard the Enterprise as Kirk took command of the ship to investigate the alien entity moving toward Earth. This costume consists of a fitted, long-sleeve tan poly-blend top with a black resin life support monitor belt buckle attached to the front, a cream-colour cotton bra, and a pair of matching tan poly-blend trousers with an elastic waistband. The interior of the top and trousers feature hand-marked Paramount labels for "Grace Whitney" in blue ink. This costume exhibits discoloration, pulled threads and frayed fibres, as well as scuffing on the buckle.

**Estimate: £3,000 - 6,000**

**1618**  
**Spock's (Leonard Nimoy)**  
**Ear Appliances**  $\Omega$   
**Star Trek:**  
**The Motion Picture (1979)**

Spock's (Leonard Nimoy) ear appliances from Robert Wise's Star Trek: The Motion Picture. Spock, who was half-Vulcan, had pointed ears that were an iconic characteristic of his character. This lot consists of a pair of foam latex pointed ear tips, painted beige to match Nimoy's skin tone. They exhibit wear from use and age, including paint chipping and tearing along the edges from where they were removed from the performer. They remain fragile and should be handled with caution. Additional Provenance: Letter of Authenticity from Jack Townsend, then-president of the Walter Koenig Fan Club, detailing him acquiring the ears during a visit to the set during the production of the film.

**Estimate: £2,500 - 5,000**



**1619**  
**Set of Starfleet**  
**Uniform Insignia Patches**  $\Omega$   
**Star Trek:**  
**The Motion Picture (1979)**

Starfleet uniform insignia patches from Robert Wise's Star Trek: The Motion Picture. USS Enterprise crew members wore Starfleet insignia patches on their uniforms that designated their departmental roles on the ship throughout the film. This set originated with a crew member from the production. It consists of an orange Sciences patch, a silver-colour Security patch, a white Command patch, a green Medical patch, a red Cadet patch, and a yellow Engineering patch. Each is made of felt embroidered with grey Starfleet insignia at their centres. These patches exhibit pulled and loose threads.

Dimensions: (each) 4.5 cm x 5.75 cm (1.75" x 2.25")

**Estimate: £2,000 - 4,000**

**1616**  
**Cast-autographed Bridge Panel**  $\Omega$   
**Star Trek: The Motion Picture (1979)**

A cast-autographed bridge panel from the production of Robert Wise's Star Trek: The Motion Picture. The panel has been autographed in silver ink by five of the principle cast members - William Shatner (James T. Kirk), George Takei (Hikaru Sulu), James Doohan (Montgomery Scott), Walter Koenig (Pavel Chekov) and Nichelle Nichols (Uhuru). It is made of acrylic and has a red plastic filter adhered to the back. Dimensions: 17 cm x 17 cm x 3 cm (6.75" x 6.75" x 1.25") The autographs in this lot have been professionally authenticated by expert Garry King; see notice in the Buyer's Guide.

**Estimate: £3,000 - 6,000**

17 cm (6.75")





**1620**  
Vulcan Citizen Costume  $\Omega$   
**Star Trek III:  
The Search For Spock (1984)**

A Vulcan citizen costume from Leonard Nimoy's Star Trek III: The Search for Spock. As the crew carried Spock's body onto the planet Vulcan for the Fal-tor-pan procedure to reunite it with his katra, Vulcan citizens gathered for the ceremony along the path Admiral Kirk (William Shatner) and the others took. This costume consists of one red and black hat with a resin ornament on the front and red ribbon straps; a red, grey, and black sash made of polyester with a resin badge on the front of the sash; and a tan polyester robe with red striping. Also included is a second triangular resin badge. The interior of the robe features a label hand-marked "3-14," the backside of the triangular badge is hand-marked "3-20," and the interior of the hat features a Paramount Studios tag hand-marked "3-14." This lot exhibits pulled and frayed threads, chipped and flaked paint, and discoloration.

**Estimate: £2,000 - 4,000**

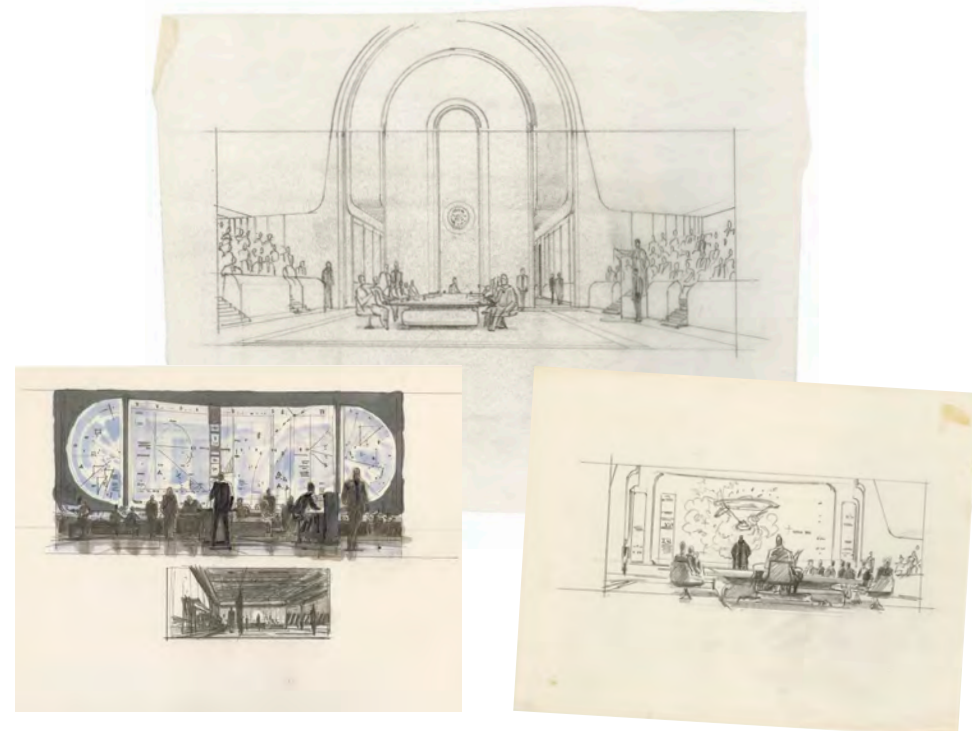

**1621**  
Set of Three Hand-drawn Ralph McQuarrie Concept Artworks  $\Omega$   
**Star Trek IV: The Voyage Home (1986)**

Three concept artworks hand-drawn by visual consultant Ralph McQuarrie for the production of Leonard Nimoy's Star Trek IV: The Voyage Home. Klingons met with Starfleet in the Federation Council Chamber to demand Admiral James T. Kirk's (William Shatner) extradition. Among the greatest-known production artists in Hollywood cinema, McQuarrie contributed concept work to such franchises as Star Wars, Indiana Jones, Close Encounters of the Third Kind, and E.T. the Extra-Terrestrial. These three storyboards depicting early concepts for the Council Chamber and other key setpieces inside bordered lines are rendered in pencils, ink, and marker on vellum and paper. The set exhibits yellow staining, uneven edges, and smudging throughout. Dimensions: (largest) 28 cm x 35.75 cm (11" x 14") Sold without copyright; see notice in the Buyer's Guide.

**Estimate: £1,500 - 3,000**



**1622**  
Hand-coloured Ralph McQuarrie Whaling Ship Storyboard  $\Omega$   
**Star Trek IV: The Voyage Home (1986)**

A whaling ship storyboard hand-coloured by visual consultant Ralph McQuarrie for the production of Leonard Nimoy's Star Trek IV: The Voyage Home. The crew of the HMS Bounty stopped a whaling vessel from harpooning George and Gracie. Among the greatest-known production artists in Hollywood cinema, McQuarrie also contributed concept work to franchises such as Star Wars, Indiana Jones, Close Encounters of the Third Kind, and E.T. the Extra-Terrestrial. This early storyboard depicting a vessel on the open water is rendered in coloured marker and graphite on art paper printed with the film's original subtitle "The Adventure Continues" and labelled for McQuarrie at the centre bottom. The paper's left corners exhibit fold lines. Dimensions: 35.75 cm x 21.75 cm (14" x 8.5") Sold without copyright; see notice in the Buyer's Guide.

**Estimate: £1,500 - 3,000**



**1623**  
Cast-autographed Photo  $\Omega$   
**Star Trek V: The Final Frontier (1989)**

A framed autographed colour publicity still featuring the USS Enterprise-A crew from William Shatner's sci-fi sequel Star Trek V: The Final Frontier. The photo has been autographed in silver-coloured ink by Shatner (Captain Kirk), Leonard Nimoy (Mr. Spock), George Takei (Sulu), DeForest Kelley (Dr. McCoy), James Doohan (Scottie), Nichelle Nichols (Uhura) and Walter Koenig (Chekov). Please note that the frame is without perspex. Dimensions: 48.25 cm x 40.75 cm x 2 cm (19" x 16" x 0.75") The autographs in this lot have been professionally authenticated by expert Garry King; see notice in the Buyer's Guide.

**Estimate: £1,000 - 2,000**



33 cm (13")



31 cm (12.25")

**1624**  
Starfleet Scanner  $\Omega$   
**Star Trek VI: The Undiscovered Country (1991)**

A Starfleet scanner from Nicholas Meyer's sci-fi sequel Star Trek: The Undiscovered Country. An Enterprise crew member used a long scanner - similar to a metal detector - to sweep the floors as they hunted for Chancellor Gorkon's (David Warner) assassins. The scanner features a steel dome with resin embellishments and detailing. The Starfleet insignia is present at the top of the scanner, near two prongs which previously connected the scanner to its handle. A lightbulb is present on the underside of the scanner and the wire connected to it has been cut since production. There is some minor paint wear and some minor chips. Dimensions: 31 cm x 31 cm x 18 cm (12.25" x 12.25" x 7") Contains electronics; see electronics notice in the Buyer's Guide.

**Estimate: £1,000 - 2,000**

**1625**  
Doctor Tolian Soran's (Malcolm McDowell)  
Light-up PADD Device  $\Omega$   
**Star Trek: Generations (1994)**

Doctor Tolian Soran's (Malcolm McDowell) light-up control PADD from David Carson's Star Trek: Generations. Soran used his PADD while he prepared to launch a probe on Veridian III. This lot consists of one green and grey resin device featuring a geometric design, static buttons with engraved symbols, a static screen with similar symbols in a spiral, and several LED lights. A switch on one side activates the lights which blink in alternating sequences, and illuminate the screen. A button on the opposite side when held changes the light sequence. This PADD device has undergone sympathetic restoration to reattach one screw panel. Also included is a hex key and a plastic, foam-filled anvil case. This lot exhibits mild discoloration, minor cracking, and a loose back panel. Dimensions: 33 cm x 23.5 cm x 12.75 cm (13" x 9.25" x 5") Contains electronics; see electronics notice in the Buyer's Guide.

**Estimate: £2,000 - 4,000**



33.25 cm (13")

**1626**  
Stunt Klingon D'K'Tahg  $\Omega$   
**Star Trek: Generations (1994)**

A stunt Klingon D'k Tahg from David Carson's Star Trek: Generations. Incensed Klingons drew their signature D'k Tahg daggers after Tolian Soran (Malcolm McDowell) hit B'Etor (Gwynyth Walsh). This D'k Tahg is made of rubber with one main blade and two static side blades all painted silver-colour and a black handle with a spiked pommel. The smaller blades have label imprints on them from the blades they were cast from. It exhibits paint chipping. Dimensions: 33.25 cm x 10.5 cm x 2.75 cm (13" x 4.25" x 1")

**Estimate: £1,500 - 3,000**



Includes pair of Alexis Bittar drop earrings

**1627**  
Lieutenant Uhura's Starfleet Uniform  $\Omega$   
**Star Trek (2009)**

Lieutenant Uhura's Starfleet uniform from J.J. Abrams' Star Trek. Uhura wore her costume while aboard the USS Enterprise. This costume consists of a pair of Alexis Bittar drop earrings, a stretchy red nylon dress, a stretchy grey nylon bodysuit with built-in shorts, a beige bra from Felina Lingerie (size 34A) with silicone straps, and a pair of black poly blend socks. Both the dress and bodysuit feature an interior Michael Kaplan costumiers label with the principal performer's name marked in both the red dress and the bodysuit. Also included is a production tag hand-marked for the principal performer as "Uhura" "Ch. 6" and a series of scenes as well as "Also Ch. 8." The production tag exhibits creasing and some discoloration around the "6."

**Estimate: £2,000 - 4,000**



Epaulette detail

**1628**  
Captain Abbot's Starfleet Dress Uniform  $\Omega$   
**Star Trek Into Darkness (2013)**

Captain Abbot's (Beau Billingslea) Starfleet dress uniform from J.J. Abrams' sci-fi action sequel Star Trek Into Darkness. Abbot, commanding officer of the USS Bradbury, wore his dress uniform when Starfleet officials met to discuss Khan's (Benedict Cumberbatch) attack on the Starfleet archive. The uniform comprises a heavy linen grey jacket and matching grey trousers. The jacket has rank badges on the epaulettes. Both feature interior labels with the name of costume designer Michael Kaplan and "Abbot" handwritten. There is some stitching on the chest where the Starfleet badge was previously held. The uniform is accompanied by two production tags with information on the items.

**Estimate: £1,000 - 2,000**



**1629**  
Mr. Spock's (Zachary Quinto) "Harness" Sciences Tunic  $\Omega$   
**Star Trek Into Darkness (2013)**

Mr. Spock's (Zachary Quinto) "harness" sciences tunic from J.J. Abrams' sci-fi action sequel Star Trek Into Darkness. Spock wore his sciences tunic while aboard the Enterprise. Made specifically for this sequel, the blue tunic (approximate size large) is made of Spandex and features a printed optical repeat Starfleet insignia pattern. The long-sleeved shirt has piping around the collar, a hidden zipper at the left shoulder and two silver bands on the wrists. The shirt features a back slit, likely used during a stunt sequence, which allowed cables to connect to a stunt harness. Also included in the lot is a wardrobe tag with hand-written notes about the costume.

**Estimate: £2,000 - 4,000**



**1630**  
Starfleet Type-1 Phaser  $\Omega$   
**Star Trek Into Darkness (2013)**

A Starfleet Type-1 phaser from J.J. Abrams' Star Trek Into Darkness. The crew of the USS Enterprise and its fellow Starfleet officers, as well as enemies such as Khan Noonien Singh (Benedict Cumberbatch), wielded standard-issue phasers throughout the film. This futuristic phaser with serial number "PLJ0924-110966" and "T1 Batt Only" engraved on its barrel is constructed from metallised resin. It features a rotating emitter on front designed to alternate between a red "kill" barrel and silver-colour "stun" barrel functions, as well as a removable magnetic compartment on top designed to conceal a tape-covered battery pack. The emitter's automated rotation is no longer functional, though it can still be rotated by hand. The phaser exhibits scuffing, discolouration, chipped paint, and exposed resin from use. Dimensions: 28 cm x 20.5 cm x 5 cm (11" x 8" x 2") Contains electronics; see electronics notice in the Buyer's Guide.

**Estimate: £3,000 - 6,000**



**1631**  
Pair of Tribbles  $\mathcal{M}$   
**Star Trek: The Original Series - The Trouble with Tribbles (1967)**

A pair of tribbles from the classic sci-fi television series Star Trek: The Original Series. Tribbles made their first appearance in the Star Trek universe in the Season 2 episode "The Trouble with Tribbles", as the USS Enterprise became overwhelmed with the small furry creatures as they multiplied exponentially. The tribbles are made of faux hair and are accompanied by letters of authenticity from David Gerrold, the writer of the episode, who was gifted the creatures by Irving Feinberg, the series' propmaster. Gerrold also helped create the original tribbles.

**Estimate: £2,000 - 4,000**



69.25 cm (27.25")



William Shatner autograph detail



**1632**  
William Shatner-autographed Framed Hand-painted Todd Treadway Captain James T. Kirk Enesco Plate Artwork with Limited-edition Collector's Plate  $\Omega$  **Star Trek: The Original Series (T.V. Series, 1966-1969)**

Artwork depicting Captain James T. Kirk (William Shatner) from Gene Roddenberry's Star Trek autographed by Shatner and hand-painted by artist Todd Treadway. Treadway created the painting for a limited-edition porcelain collector's plate released in 1994 by Enesco. This painting of Kirk with Spock (Leonard Nimoy) and Leonard "Bones" McCoy (DeForest Kelley) in front of the Enterprise comes from Treadway's collection. It is rendered in airbrushed acrylic and coloured pencil on illustration board and autographed by Shatner in black marker in the top left corner. The artwork comes mounted behind glass in a custom gold-colour frame. Also included is a limited-edition Enesco "Captain James T. Kirk" collector's plate numbered 2696 and engraved "These are the voyages of the starship enterprise" around its edge, as well as the plate's original Enesco box. The box has been opened, and the frame exhibits some streaking from handling. Dimensions: (artwork) 69.25 cm x 69.25 cm x 2 cm (27.25" x 27.25" x 1") Sold without copyright; see notice in the Buyer's Guide. Additional Provenance: Letter of Authenticity from Treadway and Certificate of Authenticity from Enesco.

**Estimate: £2,500 - 5,000**



71 cm (28")



Todd Treadway autograph detail

**1633**  
Hand-painted Todd Treadway USS Enterprise NCC-1701 Enesco Plate Artwork  $\Omega$  **Star Trek: The Original Series (T.V. Series, 1966-1969)**

Artwork depicting the USS Enterprise NCC-1701 from Gene Roddenberry's Star Trek hand-painted by artist Todd Treadway. Treadway created the painting for a limited-edition porcelain collector's plate released in 1994 by Enesco. This painting of the iconic spacecraft on its five-year journey through uncharted space comes from Treadway's collection. It is rendered in airbrushed acrylic and coloured pencil on illustration board and signed, dated "1994," and labelled "Original Art for Enesco" by Treadway in graphite. It exhibits light staining and bending around its edges. Dimensions: 71 cm x 71.25 cm (28" x 28") Sold without copyright; see notice in the Buyer's Guide. Additional Provenance: Letter of Authenticity from Treadway.

**Estimate: £2,000 - 4,000**



**1634**  
Set of Three Robert Sabaroff's Signed "The Immunity Syndrome" Scripts and Series Writer's Guide  $\Omega$  **Star Trek: The Original Series - The Immunity Syndrome (1967)**

Two scripts for the classic Season 2 episode "The Immunity Syndrome" and an original series writer's guide from Gene Roddenberry's Star Trek, all signed by "The Immunity Syndrome" writer Robert Sabaroff. "The Immunity Syndrome" won an Emmy® for its visual effects, and is often considered one of The Original Series' landmark episodes. Originally sourced directly from Sabaroff as his personal production copies, this lot consists of a 62-page photocopied first draft script; and a 66-page final draft script hand-marked "S. Sabaroff" for Sabaroff's father; and a 31-page "Star Trek Writer's Guide" issued to Sabaroff by Desilu upon receiving the writing assignment for the episode. All three are bound with brass brads and signed in ink by Sabaroff. The set exhibits minor creasing, edge wear, and staining. Dimensions: (each) 21.5 cm x 28 cm x 2.5 cm (8.5" x 11" x 1") Additional Provenance: Notarized Letter of Authenticity signed by Robert Sabaroff and dated "December 11, 2000."

**Estimate: £1,500 - 3,000**

**1636**  
Set of Five Patrick Stewart-autographed and Annotated Season 1 Scripts and Pair of Shooting Schedules  $\Omega$  **Star Trek: The Next Generation - When the Bough Breaks (1988), Coming of Age (1988)**

A set of five Patrick Stewart-autographed and annotated Season 1 scripts and a pair of shooting schedules from the series Star Trek: The Next Generation. Season 1 of The Next Generation introduced audiences to the crew of the Enterprise 1701-D under the command of Captain Jean-Luc Picard (Patrick Stewart). This lot, which originally came from the personal collection of Patrick Stewart, consists of three scripts for the episode "When the Bough Breaks" (final, revised final, and second-revised final drafts), two scripts for the episode "Coming of Age" (revised final and third-revised final drafts), various loose colour-coded revised final draft pages, and two shooting schedules. The scripts feature handwritten annotations and covers with the series title logo and the Enterprise-D, four in red and one in blue. They exhibit edge wear, minor staining, and adhesive residue where labels fell off. Dimensions: (largest) 22.25 cm x 28 cm x 0.75 cm (8.75" x 11" x 0.25")

**Estimate: £3,000 - 6,000**



**1635**  
James Doohan-signed Bound "Friday's Child" Final Draft Script  $\Omega$  **Star Trek: The Original Series - Friday's Child (1967)**

A bound final draft script for the Season 2 episode "Friday's Child" of Gene Roddenberry's Star Trek signed by James Doohan. In the landmark episode, Scotty (Doohan) took control of the Enterprise while Kirk (William Shatner), Spock (Leonard Nimoy), and Bones (DeForest Kelley) beamed down to Capella IV to get topaline mining rights. Written by D.C. Fontana, this 68-page, brass brad-bound final draft script dated "April 24, 1967" originated from the collection of Audrey Anderson, the former President of the Leonard Nimoy Fan Club. It features a grey Desilu cover signed in ink by Doohan, stamped "102," and labelled "FC B." The paper exhibits yellowing and folded corners from age and handling. Dimensions: 21.75 cm x 28 cm x 1.5 cm (8.5" x 11" x 0.5")

**Estimate: £1,200 - 2,400**



Patrick Stewart autograph detail



**1637**  
 Patrick Stewart-autographed  
 "Booby Trap" Script  
 with Four Additional Annotated  
 Season 3 Scripts  $\Omega$   
**Star Trek: The Next Generation -  
 Booby Trap (1989),  
 Evolution (1989)**

A "Booby Trap" script autographed by Patrick Stewart with four additional annotated scripts from Season 3 of Star Trek: The Next Generation. The third season marked the return of Dr. Beverly Crusher (Gates McFadden) and the debut of recurring characters such as Reginald Barclay (Dwight Schultz) and Kurn (Tony Todd). This lot originated from the personal collection of Stewart. It consists of one final draft "Booby Trap" script signed by Stewart in black ink; one revised final draft script for the episode; and three scripts (second draft, final draft, and revised final draft) for the episode "Evolution." Each of the scripts features handwritten annotations throughout, while two feature labels reading "Patrick Stewart." They exhibit some signs of use and age, including edge wear and minor staining, and two have adhesive residue where labels fell off. Dimensions: (each) 22.25 cm x 30 cm x 1.5 cm (8.75" x 11.75" x 0.5")

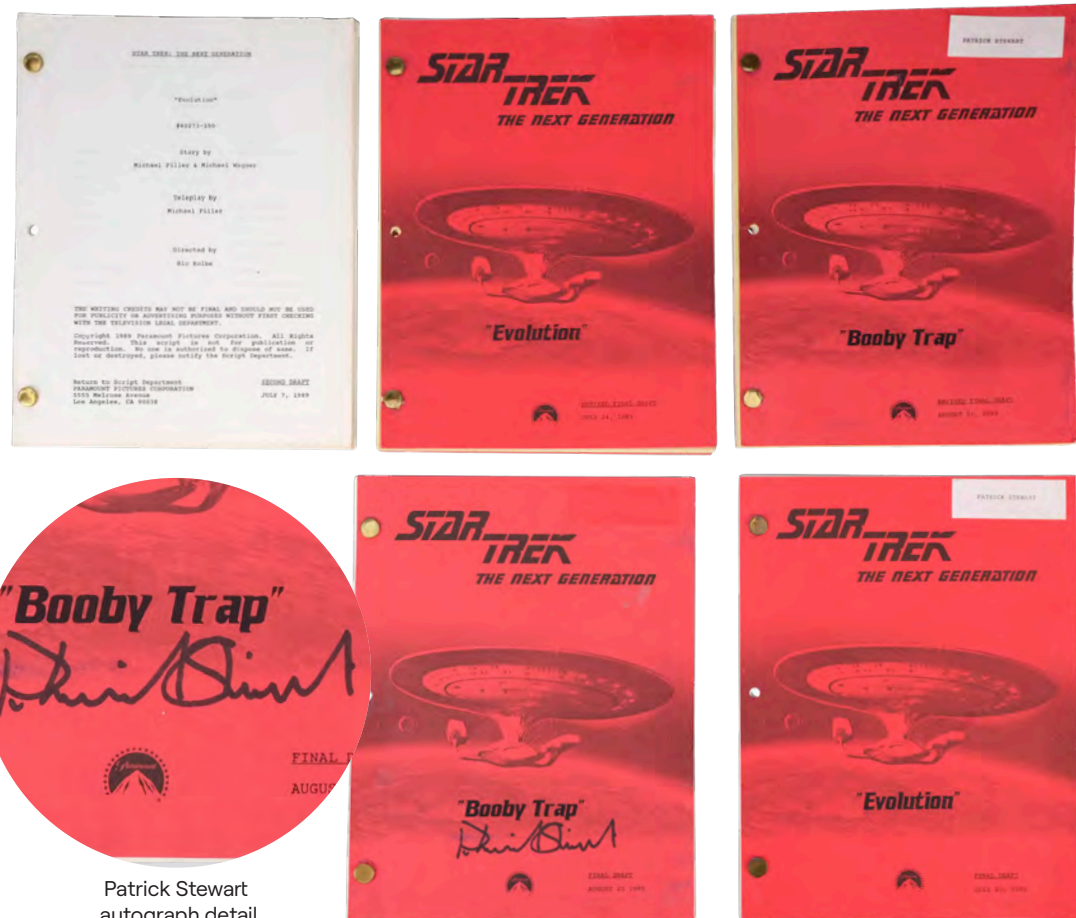

Patrick Stewart  
 autograph detail

**Estimate: £3,000 - 6,000**

**No lot 1638**



Glass vial detail

**1639**  
 Hypospray Device and Vial  $\Omega$   
**Star Trek: The Next Generation  
 (T.V. Series, 1987-1994)**

A hypospray device and vial from the sci-fi series Star Trek: The Next Generation. Hyposprays were used by medical personnel, such as Dr Beverly Crusher (Gates McFadden), to inject liquids into the body. The hypospray is made primarily of resin, with a brass nozzle at one end and a glass vial at the other. A blue-green liquid is in the vial. Dimensions: 16 cm x 3 cm x 4 cm (6.25" x 1.25" x 1.5")

**Estimate: £1,200 - 2,400**



**1640**  
 Starfleet Combadge  $\Omega$   
**Star Trek: The Next Generation (T.V. Series, 1987-1994)**

A Starfleet Combadge from Gene Roddenberry's sci-fi TV series Star Trek: The Next Generation. The design of this combadge is that of an Officer's from the 2350s to early 2365. It was worn as part of the uniform, and used to communicate with others, translate alien languages and be locked onto for transport. This resin combadge also features a costume label on the reverse. Dimensions: 5.25 cm x 4.5 cm x 0.75 cm (2" x 1.75" x 0.25")

**Estimate: £1,200 - 2,400**

**1641**  
 Hand-painted Todd Treadway  
 The Crew Enesco Plate Artwork  
 with Limited-Edition Collector's  
 Plate  $\Omega$   
**Star Trek: The Next Generation  
 (T.V. Series, 1987-1994)**

Artwork depicting the crew of the USS Enterprise (NCC-1701-D) from Gene Roddenberry's Star Trek: The Next Generation hand-painted by artist Todd Treadway. Treadway created the painting for a limited-edition porcelain collector's plate released in 1993 by Enesco. This painting of the iconic spacecraft with its main crew before it comes from Treadway's collection. It is rendered in airbrushed acrylic and coloured pencil on illustration board and signed, dated "1993," and labelled "Original Art for Enesco" by Treadway in graphite. Also included is a limited-edition Enesco "The Crew" Collector's Plate numbered 11076, as well as the plate's original Enesco box. The box is opened and exhibits some denting, while the artwork exhibits bending and light discolouration to its corners. Dimensions: (artwork) 75 cm x 76.5 cm (29.5" x 30.25") Sold without copyright; see notice in the Buyer's Guide. Additional Provenance: Letter of Authenticity from Treadway and Certificate of Authenticity from Enesco.

**Estimate: £2,500 - 5,000**





**1642**  
Hand-painted Todd Treadway  
USS Enterprise NCC-1701-D Enesco  
Plate Artwork  $\Omega$   
**Star Trek: The Next Generation**  
(T.V. Series, 1987-1994)

Artwork depicting the USS Enterprise NCC-1701-D from Gene Roddenberry's Star Trek: The Next Generation hand-painted by artist Todd Treadway. Treadway created the painting for a limited-edition porcelain collector's plate released in 1994 by Enesco. This painting of the iconic spacecraft on its journey through the Milky Way comes from Treadway's collection. It is rendered in airbrushed acrylic and coloured pencil on illustration board and signed, dated "1994," and labelled "Original Art for Enesco" by Treadway in graphite. It exhibits minor creasing and edge wear. Dimensions: 70 cm x 71.5 cm (27.5" x 28.25") Sold without copyright; see notice in the Buyer's Guide. Additional Provenance: Letter of Authenticity from Treadway.

**Estimate: £2,000 - 4,000**

No lot 1643-1644

**1645**  
Pair of Metal Bars of Gold-pressed Latinum  $\mu$   
**Star Trek: Deep Space Nine** (T.V. Series, 1993-1999)

Two metal bars of gold-pressed latinum from the Star Trek: Deep Space Nine. Latinum was a rare silver-colour liquid metal used as currency by the Ferengi and Cardassians, among others, and it was often pressed with gold into solid bars. These heavy bars are made of solid metal and coloured gold. Metal bars from production are significantly rarer than the more commonly-found resin bars. They exhibit some wear from use and age, including discolouration and spotting. Dimensions (each): 9.5 cm x 4.5 cm x 1 cm (3.75" x 1.75" x 0.5")

**Estimate: £1,000 - 2,000**



**1646**  
Odo (Rene Auberjonois) Facial Prosthetic  $\mu$   
**Star Trek: Deep Space Nine** (T.V. Series, 1993-1999)

An Odo (Rene Auberjonois) facial prosthetic from the production of Star Trek: Deep Space Nine. Shape-shifter Odo was the head of security aboard Deep Space Nine. The prosthetic is made of foam latex and painted with Odo's smooth, pinky skin tone. It has some wear from age and storage, most notably around the ears, where they have partially come away from the rest of the prosthetic. There is also some minor paint wear. The prosthetic was carefully removed and saved by Auberjonois after filming. It is accompanied by a letter of authenticity from Auberjonois' wife, Judith.

**Estimate: £2,000 - 4,000**



**1647**  
Romulan Disruptor Rifle  $\Omega$   
**Star Trek: Deep Space Nine**  
- *The Die Is Cast* (1995),  
*Message in a Bottle* (1998)

A Romulan disruptor rifle from the television series Star Trek: Deep Space Nine and Star Trek: Voyager. Romulan soldiers carried their signature rifles throughout the series, including Deep Space Nine's Season 3 Episode 21 "The Die Is Cast," and Voyager's Season 4 Episode 14 "Message in a Bottle." This resin rifle is painted metallic grey with a matte black textured grip, static blue panelling with Romulan characters etched into them, and copper-colour detailing on the body and barrel. This lot exhibits chipped paint along the corners exposing the resin beneath, and some cracking along the side. Dimensions: 47 cm x 23 cm x 7.75 cm (18.5" x 9" x 3")

**Estimate: £1,200 - 2,400**

No lot 1648

**No lot 1649**

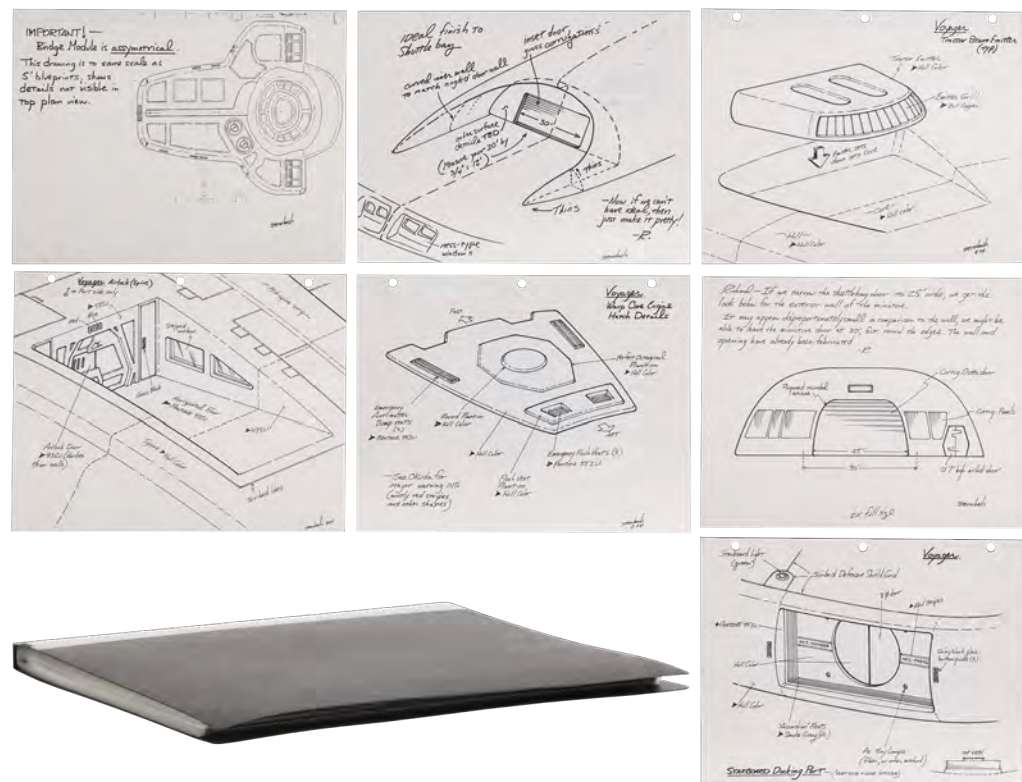

**1650**  
Hand-drawn Concept Art Binder m  
**Star Trek: Voyager**  
(T.V. Series, 1995-2001)

A concept art binder from the production of the sci-fi television series Star Trek: Voyager. Included are 33 original detail drawings, all relating to the fabrication of a Voyager miniature. Included are Vellum blueprint drawings, as well as detail drawings in blue pencil and black ink. The drawings are annotated, and drawn by Rick Sternbach, who has won two Hugo awards and one Emmy for his illustration work. All of the drawings are kept in a black plastic folder. Dimensions: 29.5 cm x 25 cm x 3 cm (11.75" x 10" x 1.25")

**Estimate: £1,000 - 2,000**

**1651**  
Sickbay Biobed LCARS Panel m  
**Star Trek: Voyager (1995-2001)**

A sickbay biobed LCARS panel from Star Trek: Voyager. High-tech biobeds used to diagnose and treat patients in the USS Voyager's sickbay were operated via LCARS panels of this style throughout Seasons 1 and 2. This panel is made of black transparent acrylic with silver-colour accents and an acetate backing for "Bio Scan Analysis 01-0731." The sheet depicts touch-screen buttons in yellow and purple featuring various numbers on them as well as sections for "Neural Activity," "Endocrine Functions," "Cell Rate," and others. The acetate sheet is taped to the back of the panel. This panel exhibits scuffing and scratching throughout the acrylic, and notable adhesive residue. Dimensions: 51 cm x 29.5 cm x 0.5 cm (20" x 11.5" x 0.5")

**Estimate: £1,200 - 2,400**

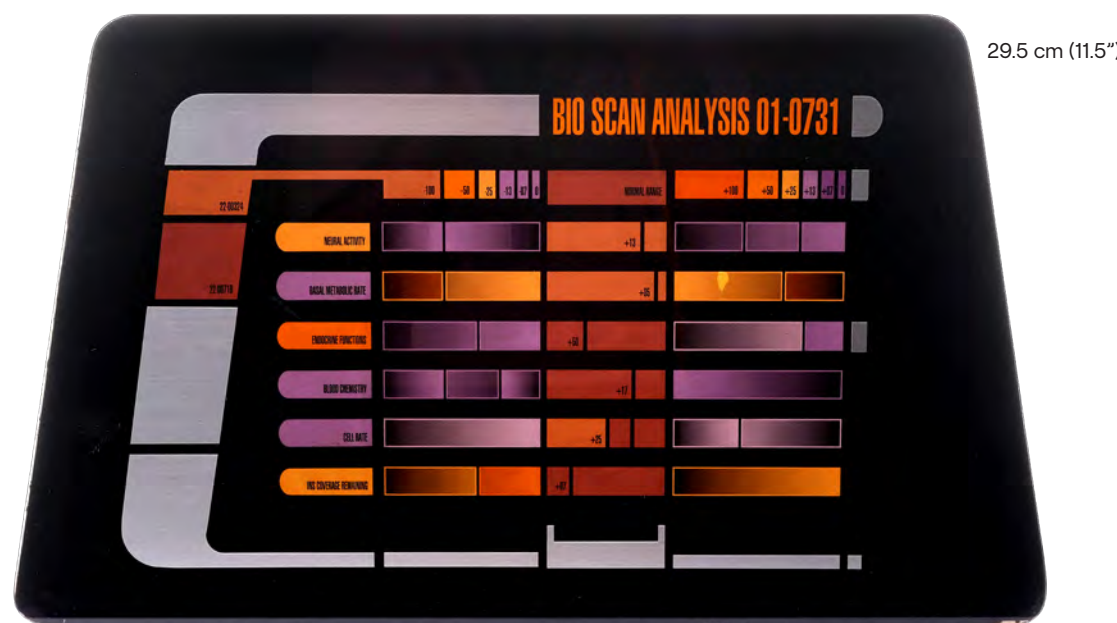

29.5 cm (11.5")

**No lot 1652**



Gold starfleet bootstrap buckle detail

**1653**  
Gabriel Lorca's (Jason Isaacs) Captain Uniform m  
**Star Trek: Discovery**  
(T.V. Series, 2017-2024)

Gabriel Lorca's (Jason Isaacs) captain uniform from Star Trek: Discovery. Lorca wore his captain's uniform while serving as commanding officer of the USS Discovery throughout the series' first season. This lot consists of a blue cotton-Spandex blend jacket marked "5 Lorca," command division, with gold-colour striping, zippers, and embellishments; a matching pair of blue and gold-colour trousers marked "#5x Lorca Stunt"; and a pair of black leatherette operations-division boots with copper-colour soles and delta attachments. The costume exhibits some scuffing to the boots.

**Estimate: £3,000 - 6,000**



Jennifer Lien autograph detail

**1654**  
Collection of Various Scripts, Shooting Schedules and Production Paperwork m  
**Star Trek: Franchise**

A collection of scripts and production paperwork from various Star Trek series and films. The lot includes one complete Enterprise script; 12 complete Deep Space Nine scripts; one complete Voyager script; a collection of revised script pages for various episodes; a large collection of shooting schedules, including Enterprise, Voyager, DS9, The Next Generation and Star Trek: Insurrection; and a DS9 series bible and technical primer. The front page of the script has been autographed by Jennifer Lien, who played Kes in the Voyager episode "Fury", and Vaughn Armstrong, who played the Vidiian Captain in the same episode. Dimensions (complete set): 29 cm x 22 cm x 27 cm (11.5" x 8.75" x 10.75")

The autographs in this lot have been professionally authenticated by expert Garry King; see notice in the Buyer's Guide.

**Estimate: £2,000 - 4,000**



Flight yoke controller detail

141 cm (55.5")

**1655**  
Vintage Full-size  
Atari Arcade Game m  
**Star Wars: A New Hope (1977)**

A vintage, full-size Atari Star Wars cockpit arcade game. Released in 1983, the game is based on the Death Star attack sequence from George Lucas' Star Wars: A New Hope, in which Luke and his Rebel allies assaulted and eventually destroyed the Death Star. Developed by Atari, this cockpit arcade game was in full working order when tested and powered via a British mains plug. Dimensions: 187 cm x 64 cm x 141 cm (73.5" x 25.25" x 55.5") Contains electronics; see electronics notice in the Buyer's Guide. Special shipping required; see special shipping notice in the Buyer's Guide.

**Estimate: £7,000 - 14,000**

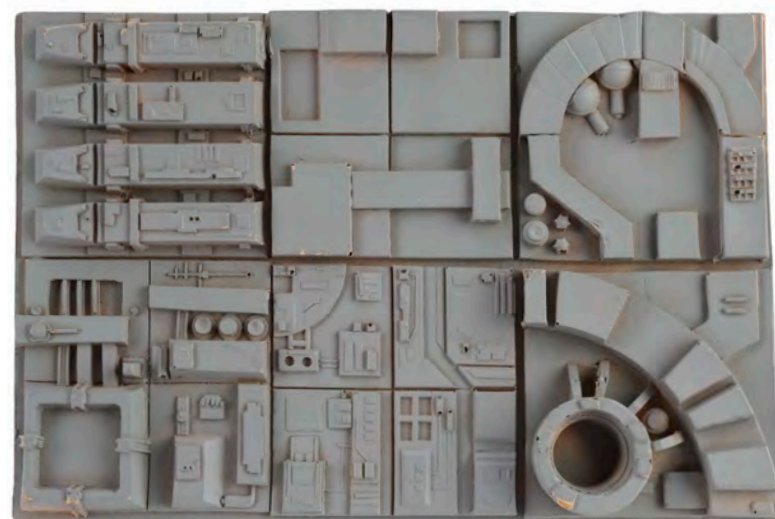

23 cm (9")

**1656**  
Low-altitude Death Star Model Miniature Surface Panel o  
**Star Wars: A New Hope (1977)**

A low-altitude Death Star model miniature surface panel from George Lucas' Star Wars: A New Hope. This panel was designed and constructed by Industrial Light & Magic (ILM) as part of the vast miniature Death Star set, specifically for shots where Rebel fighters flew close to its massive surface. Pieces of the set were later given out to attendees at the premiere of Star Wars: The Phantom Menace. This biscuit foam panel is decorated with cast greeblies of different styles and finished in industrial grey paint. Its bottom remains unpainted, and it exhibits some small fractures and grime from production and age. Dimensions: 15.25 cm x 23 cm x 2.5 cm (6" x 9" x 1")

**Estimate: £3,000 - 6,000**



66 cm (26")

**1657**  
Palitoy Action Figures Store Display Poster m  
**Star Wars: A New Hope (1977)**

A poster advertising Palitoy action figures from the release of George Lucas' Star Wars: A New Hope. These rare posters were issued to retailers to advertise the official line of Kenner-designed action figures, including the six which appear on the poster: Luke, Leia, Han, Chewbacca, Obi-Wan and R2-D2. The slogan "The toys of the film" appears across the middle in bold, white lettering, highlighting the official connection to the film. The poster has some creasing and minor edgewear. Dimensions: 66 cm x 46 cm (26" x 18")

**Estimate: £3,000 - 6,000**

**1658**  
R2-D2 Astromech Droid Neck Ring o  
**Star Wars: A New Hope (1977)**

45.75 cm (18")

An R2-D2 astromech droid neck ring from George Lucas' Star Wars: A New Hope. Astromech droids, such as R2-D2, aided the Rebel Alliance in a multitude of ways, including assisting Rebel pilots in their starfighters during the assault on the Death Star. This ring is made of wood with a silver-colour covering around the exterior and holes drilled throughout for securing it between the droid's dome and body. It exhibits scuffing throughout and a few stray blue paint marks. Dimensions: 45.75 cm x 45.75 cm x 2.75 cm (18" x 18" x 1")

**Estimate: £2,500 - 5,000**



**1659**  
ICONS X-Wing Starfighter Model Replica m  
**Star Wars: A New Hope (1977)**

An ICONS replica model of an X-Wing Starfighter from George Lucas' sci-fi adventure Star Wars: A New Hope. Luke Skywalker (Mark Hamill) and Rebels piloted X-Wing Starfighters when they destroyed the Death Star. Icons access the original screen-used artefacts and their master moulds when producing studio-authenticated 1:1 scale replicas like this X-Wing. The replica features Luke and R2-D2 in its cockpit and is displayed on a platform designed to look like the surface of the Death Star. This was, of course, the location for the film's climatic finale, with Luke firing the shot that destroyed the Galactic Empire's devastating planet-destroying weapon. Dimensions: 59.75 cm x 51.75 cm x 30.25 cm (23.5" x 20.5" x 12")

**Estimate: £2,500 - 5,000**



**1660**  
UK Quad Poster (Pre-Oscar Awards Style) +  
**Star Wars: A New Hope (1977)**

A UK Quad poster from the release of George Lucas' Star Wars: A New Hope. This poster is the Style C or "Pre-Oscars Variant" of the UK Quad and it features iconic artwork by British artist Tom Chantrell. This version of the poster was quickly replaced with the "Oscar" variation once the nominations were released, making this iteration the scarcer and more collectable of the two Chantrell UK Quads. Chantrell was allowed to preview the film and was supplied with photographic stills to aid his design, and also used photos of his wife in their back garden, posing as Princess Leia, as reference images for the artwork. The poster is presented in original folded (as issued), unrestored condition. It remains in very fine condition. Dimensions: 76 cm x 101 cm (30" x 40")

**Estimate: £2,000 - 4,000**



101 cm (40")



Includes unique # 1144/1500 limited edition plaque from Master Replicas

**1661**  
**ICONS Imperial TIE Fighter Model Replica m**  
**Star Wars: A New Hope (1977)**

An ICONS replica model of a TIE Fighter from George Lucas' sci-fi adventure Star Wars: A New Hope. Pilots of the Galactic Empire flew TIE Fighters when attempting to defend the Death Star from the Rebel attack. Icons access the original screen-used artefacts and their master moulds when producing studio-authenticated 1:1 scale replicas like this TIE Fighter. This replica is displayed on a platform designed to look like the surface of the Death Star that the TIE Fighters sought to defend. The replica is accompanied by a certificate of authenticity from its maker, Icons Replicas, with full Lucasfilm Ltd. licensing. A display plaque states that this is replica number 1,414 of 1,977 produced. Dimensions: 43.25 cm x 43.25 cm x 52.75 cm (17" x 17" x 20.75")

**Estimate: £2,000 - 4,000**

**1663**  
**Alec Guinness**  
**-Autographed Photograph tΔ**  
**Star Wars: A New Hope (1977)**

An autographed black-and-white photograph of Alec Guinness in character as Obi-Wan Kenobi from George Lucas' Star Wars: A New Hope. The image features a close-up of Guinness in his Jedi robes. It is autographed by Guinness in blue ink and inscribed "Good Wishes" near the lower left corner. There are handwritten annotations on the reverse of the photo, which read "Sir Alec Guinness, Please Sign The Front". Dimensions: 25.5 cm x 20.5 cm (10" x 8") The autographs in this lot have been professionally authenticated by expert Garry King; see notice in the Buyer's Guide.



"Good wishes. Alec Guinness." autograph detail



**Estimate: £1,000 - 2,000**

**1662**  
**Master Replicas Han Solo Blaster m**  
**Star Wars: A New Hope (1977)**

A Master Replicas reproduction of Han Solo's (Harrison Ford) blaster from George Lucas' Star Wars: A New Hope. Solo carries his signature sidearm, the Blastech DL-44, throughout the film, using it in a number of altercations, from a bar fight to fending off Stormtroopers. The blaster is made of metal, and comes with its original paperwork, including a certificate of authenticity. It also comes with a plaque, which pronounces its limited edition number "1144" out of only 1500 made by Master Replicas. The blaster features some moving parts: the trigger depresses, and the hammer can be pulled back and cocked. The paperwork comes in its original envelope, which is torn. Otherwise, the item remains in excellent condition. Dimensions (blaster): 30cm x 20cm x 7.5cm (12" x 8" x 3") Restricted ownership; see replica firearm notice in the Buyer's Guide.

**Estimate: £2,000 - 4,000**

**1664**  
**Master Replicas Obi Wan Kenobi Lightsaber m**  
**Star Wars: A New Hope (1977)**

A Master Replicas Obi-Wan Kenobi (Alec Guinness) lightsaber, based on the lightsaber the heroic Jedi wielded in George Lucas' sci-fi adventure Star Wars: A New Hope.

Obi-Wan fought with his lightsaber throughout the film, including during his duel on the Death Star against Darth Vader (David Prowse).

This officially licenced replica was recreated from original Lucasfilm archival materials, including an examination of the original screen-used prop. The lightsaber is crafted predominantly from chrome silver and black coloured metals. It is displayed on a resin base, under an acrylic cover, and is accompanied by a display plaque identifying it as replica number "1229/2500". The lightsaber also comes with its original packaging, storage case and a certificate of authenticity from Master Replicas.

The lightsaber has been intentionally distressed and weather to appear lightly rusted. Dimensions (mounted on display): 37 cm x 14.25 cm x 13.5 cm (14.5" x 5.75" x 5.25")

**Estimate: £1,000 - 2,000**

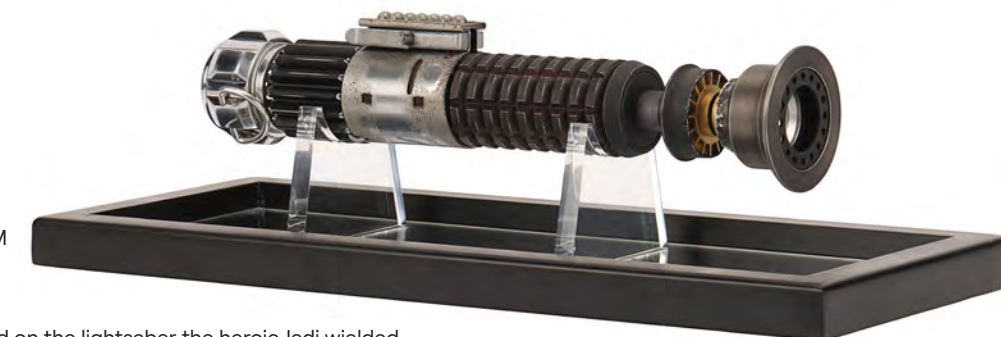

104 cm (41")

**1665**  
**US One Sheet "Style A" Poster n**  
**Star Wars: A New Hope (1977)**

A US One Sheet "Style A" poster from the promotion of George Lucas' Star Wars: A New Hope. This poster features the iconic artwork of American poster artist Tom Jung. Given the enormous success of the film, there were four separate print runs for the Style-A US One Sheet poster featuring Jung's artwork. This particular example has no "PG" Rating Box indicating this was for International use with the "77/21-0" National Screen Services reference number indicating a true First printing. The poster was issued tri-folded but has been stored flat for decades. Dimensions: 104 cm x 68.5 cm (41" x 27")

**Estimate: £800 - 1,600**



104 cm (41")

**1666**  
**US One Sheet "Style D" Poster - Alternative Font m**  
**Star Wars: A New Hope (1977)**

A US One Sheet "Style D" poster with an alternative font from the promotion of George Lucas' Star Wars: A New Hope. An exceptionally rare poster from the series. Unlike the regular and more common Style D design which has a 'funky text' font, this is printed with a more standard and formal lettering in the credits area and is one of only a very small number known to exist. When Star Wars was re-released during the summer of 1978, George Lucas was looking for a new look to refresh the poster campaign, one that would convey the fun and swashbuckling appeal of the film. The "Style D", also known as the "Circus Poster" created by Charles White III and Drew Struzan, certainly fulfilled the brief. It exhibits a distressed finish, displaying the look of a torn poster placed on a rough plywood wall with additional images plastered alongside. It was created out of necessity as the typography and credit block would not fit within the original image area. Dimensions: 104.25 cm x 68.5 cm (41" x 27")

**Estimate: £800 - 1,600**

**1667**  
DeAgostini Millennium Falcon Model Replica 1:64  
**Star Wars: A New Hope (1977)**

A replica Millennium Falcon model. This 1:64-scale replica resin and plastic model was constructed from parts that came with weekly issues of DeAgostini Build the Millennium Falcon magazine. A removable upper panel reveals the interior and a remote control powers the ramp and lights. The wall-mount bracket and remote are in a white card box. Dimensions: 80 cm x 60 cm x 23 cm (30.75" x 23" x 85.75")



Interior detail

**Estimate: £800 - 1,600**



**1668**  
R2-D2 Astromech Droid Spare Components m  
**Star Wars: The Phantom Menace (1999)**

A set of R2-D2 (Kenny Baker) astromech droid spare components from George Lucas' Star Wars: The Phantom Menace. This lot includes unpainted components from R2-D2's legs, eye, arm, and vents, as well as small miscellaneous pieces. Each of the pieces is made of solid resin. The resin on the larger leg components is prone to flaking, but otherwise the items remain in excellent condition. Dimensions (large leg component): 36 cm x 21 cm x 12 cm (14" x 8" x 5")

**Estimate: £800 - 1,600**



**1669**  
US One Sheet "Style C" Poster m  
**Star Wars: A New Hope (1977)**

A US One Sheet "Style C" poster from the promotion of George Lucas' Star Wars: A New Hope. This poster features the iconic artwork of Tom Chantrell. It is an original first-release poster and, unlike later reproductions, does not show a "hair" on Leia's back or at the base of R2-D2. Being "International", it lacks the rating box and NSS information that is displayed on the "domestic" variant. The poster was issued tri-folded but has been stored flat for decades. Dimensions: 104 cm x 68.5 cm (41" x 27")

**Estimate: £700 - 1,400**

**no lot 1670**



**1671**  
Lucite Star Crew Gift m  
**Star Wars: A New Hope (1977)**

A Lucite star crew gift from the production of George Lucas' Star Wars: A New Hope. Engraved Lucite stars were given to cast and crew in commemoration of their work on the movie, as well as to select attendees of exclusive screenings. The clear acrylic star, meant originally to be used as a paperweight, features the words "May The Force Be With You" engraved on the back. It exhibits signs of minor wear and scratching. Dimensions: 13 cm x 13 cm x 2.5 cm (5.25" x 5.25" x 1")

**Estimate: £500 - 1,000**

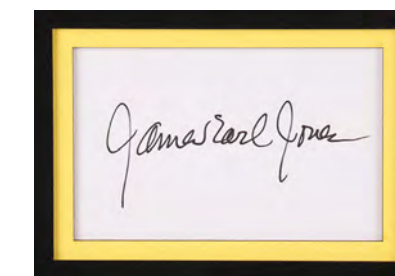

Alec Guinness and James Earl Jones autograph detail

**1672**  
Alec Guinness and James Earl Jones Autograph Display m  
**Star Wars: A New Hope (1977)**

An Alec Guinness and James Earl Jones autograph display from George Lucas' Star Wars: A New Hope. The display features an image of Darth Vader (James Earl Jones) and Obi-Wan Kenobi (Alec Guinness) engaged in a lightsaber fight, beneath which the actors' autographs are displayed. The display also includes the Star Wars logo and the words "Original autograph of James Earl Jones and Alec Guinness". The display is mounted in a wooden frame. Dimensions: 49 cm x 37.5 cm x 2.5 cm (19.25" x 14.75" x 1") The autographs in this lot have been professionally authenticated by expert Garry King; see notice in the Buyer's Guide.

**Estimate: £500 - 1,000**



**1673**  
**Norwegian Unit Crew Jacket and Trousers m**  
**Star Wars: The Empire Strikes Back (1980)**

A Norwegian unit crew jacket and trousers from the production of Irvin Kershner's Star Wars: The Empire Strikes Back. Jackets and trousers were given to members of the Norway crew for the location filming of the Hoth battle sequences. Nearly 45 years after the film's release, this combination of jacket and trousers is a rare find in the market. The blue insulated polyester jacket is a US size "44", and the matching trousers are a US size "42." The jacket features an "Empire Strikes Back" patch sewn to the right chest, a blue "Norwegian Unit" patch attached to the left chest pocket flap, and a blue "Star Wars" patch on the left sleeve. It exhibits dark stain marks from production use, and the Velcro under the left chest pocket has detached slightly, though it remains completely functional.

**Estimate: £3,000 - 6,000**

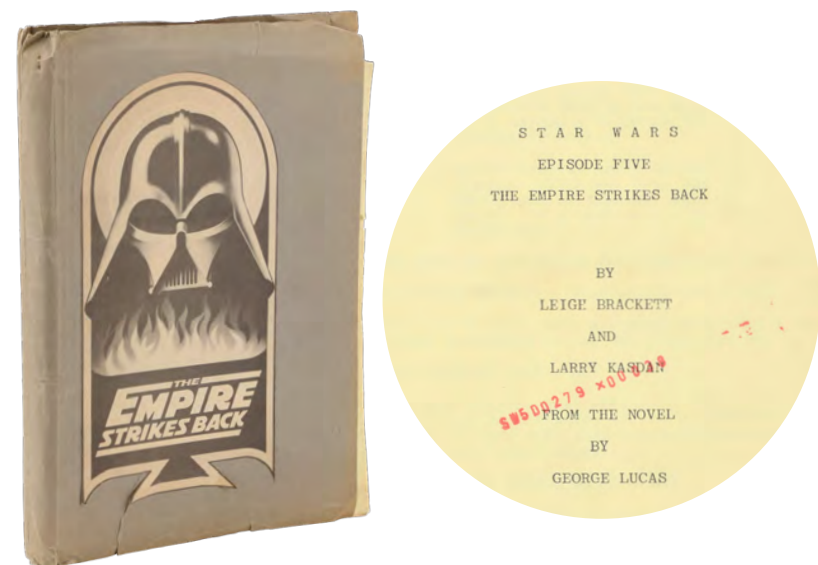

**1674**  
**Production Shooting Script m**  
**Star Wars: The Empire Strikes Back (1980)**

A shooting script from the production of Irvin Kershner's Star Wars: The Empire Strikes Back. The script is a fifth draft, titled "Episode Five: The Empire Strikes Back" and credited to Leigh Brackett and Larry Kasdan. It belonged to Don Wortham, a sound boom operator on the film. It is 435 pages long, and comprises yellow, pink, green, blue and white pages, each colour indicative of a different revision. The yellow pages are dated "2/20/79", the green "2/24/79", the pink "3/19/79", the blue "7/23/79", and the white "8/28/79". Some of the pages feature handwritten annotations, and the script is bound in a card cover featuring the film's logo. The lot exhibits some staining, dog-earing and tearing, but remains in very good condition. Dimensions: 30 cm x 24 cm x 2 cm (11.75" x 9.5" x 0.75")

**Estimate: £3,000 - 6,000**



**1675**  
**Master Replicas Signature Boba Fett Blaster m**  
**Star Wars: The Empire Strikes Back (1980)**

A Master Replicas signature edition Boba Fett (Jeremy Bulloch) blaster, based on the gun the infamous bounty hunter wielded in Richard Marquand's Star Wars: Return of the Jedi. During a chaotic skirmish above the Sarlacc pit, Luke Skywalker (Mark Hamill) cut Boba Fett's blaster in half before the bounty hunter fell into the creature's mouth, meeting his demise. This officially licenced signature edition replica was recreated with reference to original Lucasfilm archival materials, including an examination of the World War I flare gun on which the blaster was based. The replica is crafted from metal, displayed on a plastic base under an acrylic cover, and accompanied by a display plaque identifying it as number "0302 of 1000". This plaque is autographed in black marker pen by Bulloch. The lot comes with a certificate of authenticity from Master Replicas that also features a photograph of Bulloch autographing the plaque. Dimensions (mounted on display): 92 cm x 21 cm x 32.25 cm (36.25" x 8.25" x 12.75")

**Estimate: £3,000 - 6,000**



Includes unique # 302/1000 hand-signed plaque by Jeremy Bulloch along with the original Master Replicas certificate of authenticity



205 cm (80.75")



Includes unique # 660/2500 brass-coloured metal plaque

**1676**  
**Illusive Concepts Han Solo Frozen in Carbonite Replica m**  
**Star Wars: The Empire Strikes Back (1983)**

An Illusive Concepts replica Han Solo (Harrison Ford) frozen in carbonite from the promotion of Irvin Kershner's Star Wars: The Empire Strikes Back. Darth Vader (David Prowse) had Han Solo frozen in carbonite before handing him over to the bounty hunter Boba Fett (Jeremy Bulloch). Created by Illusive Concepts, this replica was produced using the original moulds from the Lucasfilm archives and was retailed as a collectable in 1997. It comprises a cast fibreglass shell with a particle-board backing and features five intricately designed side control panels. A brass-coloured metal plaque at the base of the replica has "Han Solo in Carbonite" engraved on it, and is numbered "660 of 2,500". Dimensions: 205 cm x 80 cm x 32 cm (80.75" x 31.5" x 12.75") Special shipping required; see notice in the Buyer's Guide.

**Estimate: £3,000 - 6,000**



**1677**  
**Luke Skywalker (Mark Hamill) Prototype Blaster Holster m**  
**Star Wars: The Empire Strikes Back (1980)**

A prototype Luke Skywalker (Mark Hamill) blaster holster from the production of Irvin Kershner's Star Wars: The Empire Strikes Back. Luke wore a holster for his blaster throughout the film, from the early scenes on Hoth to the climactic battle against Darth Vader (David Prowse) on Cloud City. This is a prototype of the holster seen in the film. The holster worn by Luke is made of brown leather, whereas this has been finished in black. It features one loop to attach it to a belt, and another to secure it to the leg, with metal studs on the belt loop and metal poppers on the leg loop. There are formed impressions of the blaster on both sides of the holster - evidence that it was tested with a dressed prop gun for fit and form. Dimensions: 37 cm x 13.5 cm x 5 cm (14.5" x 5.25" x 2")

**Estimate: £2,000 - 4,000**



**1678**  
**Hand-drawn Joe Johnston Storyboard Sketch and Hand-illustrated Dave Carson Storyboard m**  
**Star Wars: The Empire Strikes Back (1980)**

A hand-drawn Joe Johnston storyboard sketch with a more complete illustration of that storyboard hand-rendered by Dave Carson for the production of Irvin Kershner's Star Wars: The Empire Strikes Back. Industrial Light & Magic (ILM) visual effects art director Johnston created quick storyboard outlines in pencil to convey his ideas for a sequence, then passed them on to other ILM staff, including Carson, to complete in more detail. This lot consists of a pencil sketch by Johnston labelled "CE 17" depicting the Millennium Falcon and TIE-fighters, as well as a more-detailed ink illustration of the same sequence labelled "CE 17 Added 11.7.79" and initialled "DC." They exhibit minor crinkling and discolouration from use and age. Dimensions: (each) 26.75 cm x 21.75 cm (10.5" x 8.5") Sold without copyright; see notice in the Buyer's Guide.

**Estimate: £2,000 - 4,000**

**1679**  
Master Replicas Studio Scale Snowspeeder m  
**Star Wars: The Empire Strikes Back (1980)**

A Master Replicas studio-scale model of a snowspeeder from Irvin Kershner's Star Wars: The Empire Strikes Back. Luke Skywalker (Mark Hamill) and his fellow rebels flew T-47 snowspeeders during the battle of Hoth, where they fought off the Imperial AT-AT walkers. Different-sized models were used for filming, but Master Replicas focused on recreating the 21-inch studio-scale model of Luke's snowspeeder, identifiable by its grey stripes. This officially licenced replica was recreated with reference to Lucasfilm archival materials, including a digital scan of the original model. The replica is made of CNC machine plastic and metal, with a fuselage cast in durable resin and twin blasters made of machined aluminium with plastic detailing. The snowspeeder is displayed on a resin base under an acrylic cover and is accompanied by a certificate of authenticity, as well as a display plaque identifying it as "566/1500". Dimensions (mounted on display): 45.5 cm x 42 cm x 18.75 cm (18" x 16.5" x 7.5")



**Estimate: £2,000 - 4,000**

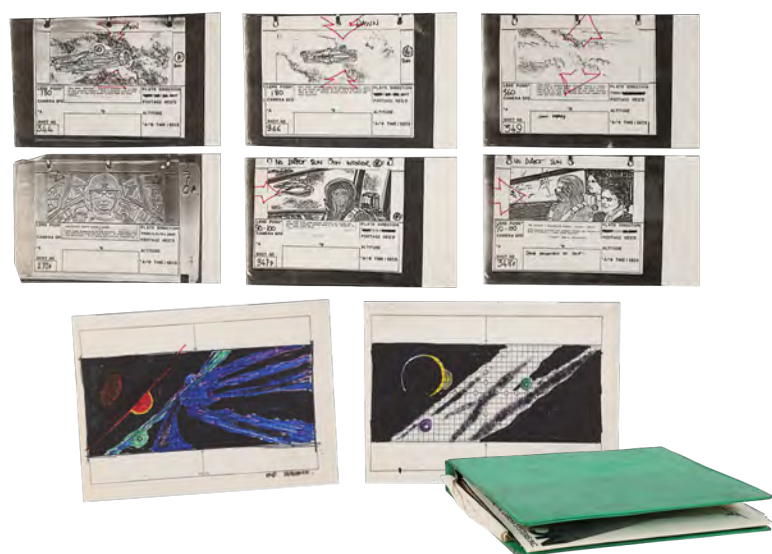

**1680**  
Cloud City Storyboard and Photo Reference Binder tΔ  
**Star Wars: The Empire Strikes Back (1980)**

A Cloud City photo reference binder from the production of Irvin Kershner's Star Wars: The Empire Strikes Back. This binder contains information on how many shots of the iconic Cloud City were required - specifically those using "Astrovision Plates", which were achieved using planes or helicopters. The binder is made of green plastic with "Cloud City Photo Ref." written on the spine in black pen. It contains an annotated information booklet on Astrovision; pages cut from magazines with reference photos of large cloud formations; hand-drawn and coloured visualisations of shots; a single photograph showing a special effect; a camera and accessories shopping list; four blank employee expense reports; and 32 miniature storyboards featuring hand-drawn arrows. The binder has wear from production use and age, most notably areas of grime and mould on the cover, and some of the pages are creased and torn. However, the lot remains in overall good condition. Dimensions: 29 cm x 25 cm x 4 cm (11.5" x 10" x 1.5")

**Estimate: £1,500 - 3,000**

**1681**  
Master Replicas AT-AT Imperial Walker Model Replica m  
**Star Wars: The Empire Strikes Back (1980)**

A Master Replicas AT-AT model display from the promotion of Irvin Kershner's Star Wars: The Empire Strikes Back. These gigantic four-legged Imperial vehicles were memorably deployed during the Battle of Hoth sequence, in which they assaulted rebel ground troops. Master Replicas based this model on the 19"-high studio models used during the production. The replica's head and body is cast from resin, and many of the finer parts have been reproduced from injection-moulded plastic. The legs are made from thermoplastics and die-cast metal. Each AT-AT replica in the limited edition run of 1,000 comprises over 230 separate parts. The piece comes with a custom acrylic display case, but is no longer accompanied by the Master Replicas plaque. Dimensions (display case): 69 cm x 28 cm x 53 cm (27" x 11" x 21")

**Estimate: £1,500 - 3,000**



**1682**  
Set of Cast-Autographed Photos and Programmes m  
**Star Wars: The Empire Strikes Back (1980)**

A set of cast-autographed photos and programmes from the production of Irvin Kershner's Star Wars: The Empire Strikes Back. Included in this lot are four black-and-white autographed photos of the key cast members from the original trilogy: Mark Hamill (Luke Skywalker), Harrison Ford (Han Solo), Carrie Fisher (Leia Organa), and Anthony Daniels (C-3PO). Each of the actors has written a message alongside their autograph. Also included are three programmes, a number of printed interviews with cast and crew of the film published by the Official Star Wars Fan Club, and an unautographed black-and-white still from the film which features the Jawas ambushing R2-D2. Dimensions: 30 cm x 24 cm x 1 cm (11.75" x 9.5" x 0.5") The autographs in this lot have been professionally authenticated by expert Garry King; see notice in the Buyer's Guide.

**Estimate: £1,000 - 2,000**

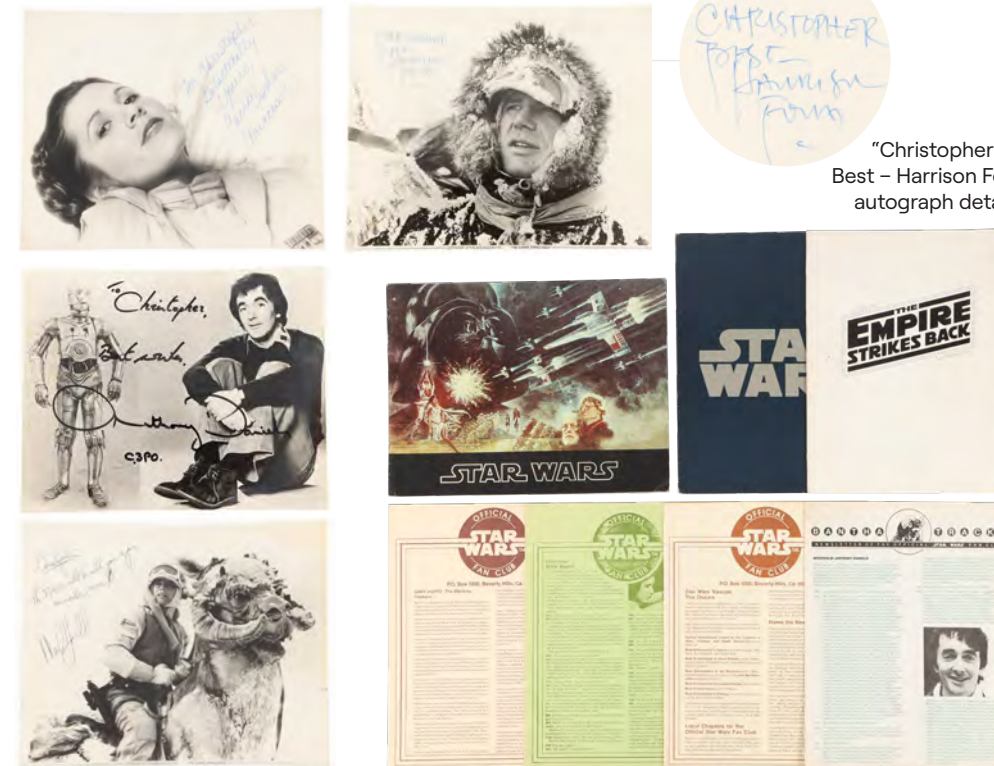

"Christopher Best - Harrison Ford" autograph detail



**1683**  
Hand-sketched Ralph McQuarrie Title Concept Art m  
**Star Wars: The Empire Strikes Back (1980)**

A piece of hand-sketched Ralph McQuarrie title concept art from the production of Irvin Kershner's Star Wars: The Empire Strikes Back. Legendary American designer McQuarrie has hand-sketched this original concept design for the film's title artwork in black ink on cream-coloured paper. Dimensions: 10.75 cm x 9.5 cm (4.25" x 3.75")

**Estimate: £800 - 1,600**



**1684**  
Yoda's (Frank Oz) Necklace Thong m  
**Star Wars: The Empire Strikes Back (1980)**

Yoda's (Frank Oz) necklace thong from Irvin Kershner's sci-fi sequel Star Wars: The Empire Strikes Back. Living on Dagobah, Yoda wore a necklace attached to a blissl, a flute-like instrument. This necklace thong was originally from the collection of make-up artist Stuart Freeborn. Released in 2023, Star Wars: 100 Objects details how Yoda's blissl was imperative to him, ensuring his psychological well-being remained intact whilst living in exile on Dagobah. This brown faux leather thong is without the blissl that completed the necklace. Instead, it is secured at one end by a wardrobe label with "Yoda Trinket" handwritten in black marker pen. Dimensions: (laid out) 41 cm x 0.5 cm x 0.5 cm (16.25" x 0.25" x 0.25")

**Estimate: £600 - 1,200**



**1685**  
Signed-on-Set Collection of Main Character Autographs m  
**Star Wars: The Empire Strikes Back (1980)**

A signed-on-set collection of main cast member autographs from Irvin Kershner's Star Wars: The Empire Strikes Back. The collection includes autographs in black ink by David Prowse (Darth Vader), Mark Hamill (Luke Skywalker), Carrie Fisher (Princess Leia), Peter Mayhew (Chewbacca), Kenny Baker (R2-D2), Anthony Daniels (C-3PO), Harrison Ford (Han Solo), and Billy Dee Williams (Lando Calrissian). The autograph of Emmy-nominated actress Stefanie Powers is found in blue ink on the opposite side of the Billy Dee Williams autograph. A second David Prowse autograph is included, this time in blue ink. Each autograph is rendered on a piece of coloured paper. Dimensions: 13.5 cm x 8.25 cm (5.25" x 3.25") The autographs in this lot have been professionally authenticated by expert Garry King; see notice in the Buyer's Guide.



**Estimate: £600 - 1,200**

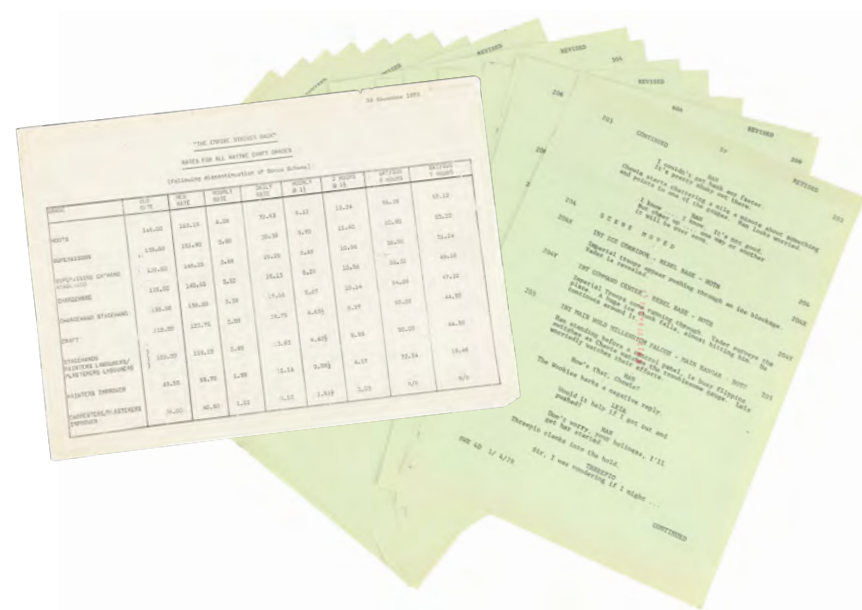

**1686**  
Script Pages and Rates List m  
**Star Wars: The Empire Strikes Back (1980)**

Loose script pages and a rates list from the production of Irvin Kershner's Star Wars: The Empire Strikes Back. The lot features 23 loose script pages printed on green paper. Each is labelled "Revised", is individually dated and is stamped with a production code. The pages are accompanied by a rates list, detailing the cost of various production roles. It is dated "24 November 1978" and has construction manager Bill Welch's name handwritten in pencil in the top right corner. All the pages have wear from production use and age, including minor staining and creasing. Dimensions (each script page): 30 cm x 21 cm (11.75" x 8.25")

**Estimate: £600 - 1,200**



**1687**  
Vader in Flames and Norwegian Unit Crew Patches, Jacket Drawstring, T-Shirt and Socks m  
**Star Wars: The Empire Strikes Back (1980)**

Crew patches, a jacket drawstring, a T-shirt, and socks from the production of Irvin Kershner's Star Wars: The Empire Strikes Back. The T-shirt is white with a printed image of Darth Vader in flames and text reading "Star Wars The Empire Strikes Back" on the front, while one of the patches features the same image, again with the film's title, and the other reads "Norwegian Unit". The socks and drawstring are both blue.

**Estimate: £500 - 1,000**



**1688**  
Collection of White Horse Toy Company R2-D2 Photographs m  
**Star Wars: The Empire Strikes Back (1980)**

A collection of White Horse Toy Company R2-D2 photographs from the production of Irvin Kershner's Star Wars: The Empire Strikes Back. Tony Dyson's White Horse Toy Company built the eight new R2-D2s used in The Empire Strikes Back alongside those from the previous film. This lot comprises two collages with early photographs of the R2-D2s and the company's team members. The reverse sides feature photographs of some of the company's other work, including their stage designs for musical acts Mike Oldfield, Thin Lizzy, and Smokie. In addition to the collages, there are two loose photographs. Dimensions (one collage): 40.75 cm x 30.5 cm (16" x 12")

**Estimate: £500 - 1,000**

**1690**  
EFX Artist Proof "Legend Edition" Scout Trooper Helmet and Blaster Replicas with Hand-drawn Nilo Rodis-Jamero Design Sketch m  
**Star Wars: Return Of The Jedi (1983)**

Artist proofs of EFX's Legend Edition Scout Trooper helmet and blaster replicas based on Richard Marquand's Star Wars: Return of the Jedi with a design sketch by the film's costume designer, Nilo Rodis-Jamero. In the film, Scout Troopers, aka Biker Scouts, wore their distinctive helmets as they drove through Endor on their 74-Z Speeder Bikes in pursuit of the Rebels. Created by EFX using the original screen-used costume and props, this lot consists of a vacuum-formed plastic Scout Trooper helmet with painted details, speckling throughout to appear distressed, and foam and mesh padding; a resin and metal stand mounted with a blaster pistol replica; a metal nameplate autographed by Rodis-Jamero with serial number "Artist Proof" and worldwide edition number "500"; an EFX information pamphlet featuring a licensed authenticity, registration card, return policy notice, warning notice, and envelope; an EFX Legend Edition Replica Scout Trooper Helmet placard; and a sketch of a Scout Trooper wielding a blaster pistol rendered, signed, and dated "2024" by Rodis-Jamero in graphite and ink on drawing paper. The original tape on the envelope is torn. Dimensions: (display) 45.75 cm x 23 cm x 25.5 cm (18" x 9" x 10")

**Estimate: £2,000 - 4,000**



**1689**  
Irvin Kershner-autographed C-3PO Photo m  
**Star Wars: The Empire Strikes Back (1980)**

An Irvin Kershner-autographed C-3PO photo from the production of his sequel Star Wars: The Empire Strikes Back. Kershner has autographed this photograph, which depicts him directing C-3PO (Anthony Daniels), in the bottom left corner in black marker pen. The lot is accompanied by a certificate of authenticity. Dimensions: 25.5 cm x 20.25 cm (10" x 8") The autographs in this lot have been professionally authenticated by expert Garry King; see notice in the Buyer's Guide.

**Estimate: £400 - 800**



Includes unique "Artist Proof" hand-signed plaque by Nilo Rodis-Jamero from EFX Collectibles.

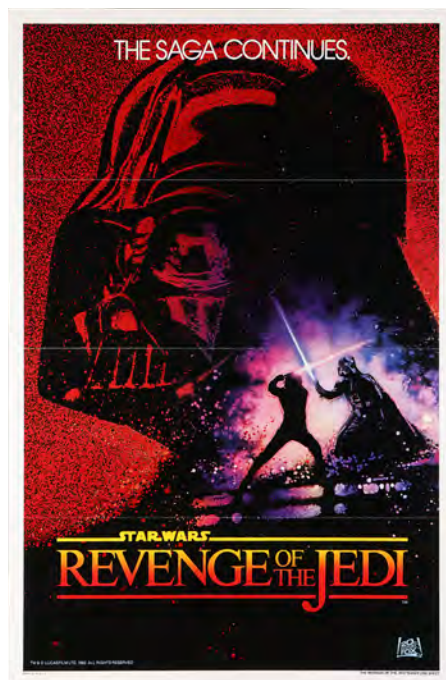

104 cm (41")

**1691**  
 Revenge of the Jedi Undated Teaser One Sheet m  
**Star Wars: Return Of The Jedi (1983)**

A 'Revenge of the Jedi' teaser One Sheet poster from Richard Marquand's Star Wars: Return of the Jedi. Early teaser posters illustrated by artist Drew Struzan featured the film's title, Revenge of the Jedi, before it was replaced with the film's final title: Return of the Jedi. Teaser posters printed with the working title were distributed in 'dated' and 'undated' versions. This glossy colour One Sheet featuring Luke Skywalker (Mark Hamill) and Darth Vader (David Prowse) duelling is the much scarcer 'undated' example. It comes in excellent tri-folded (as issued) condition. Dimensions: 69 cm x 104 cm (27" x 41")

**Estimate: £1,000 - 2,000**

**1693**  
 Sarlak Pit, Bunker Door Panel  
 and Door Detail Dyelines m  
**Star Wars:  
 Return Of The Jedi (1983)**

Sarlak pit, bunker door panel, and door detail dyelines from the production of Richard Marquand's Star Wars: Return of the Jedi. Included in this lot are three hand-drawn dyeline diagrams of set and visual effects details. The door panel and detail diagrams are extensively annotated, and the Sarlak pit diagram is scaled. Each of the diagrams has been folded for storage, but otherwise they remain in very good condition. Dimensions: 35.5 cm x 26.5 cm (14" x 10.5") Sold without copyright; see copyright notice in the Buyer's Guide.

**Estimate: £800 - 1,600**

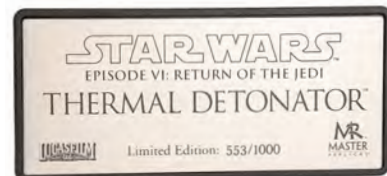

Includes unique # 553/1000 limited edition plaque from Master Replicas

**1692**  
 Master Replicas Thermal Detonator m  
**Star Wars: Return Of The Jedi (1983)**

A Master Replicas reproduction of the thermal detonator in Richard Marquand's Star Wars: Return of the Jedi. Leia Organa (Carrie Fisher) disguised as the Bounty Hunter Boushh, used the detonator to convince Jabba the Hutt to negotiate a better price for the captive Chewbacca. This spherical detonator is made of die-cast metal, intentionally weathered to appear like the one seen on screen. It comprises two halves which twist open to reveal a battery chamber. Sliding the switch at the top of the device activates three flashing white LEDs along the middle and a red LED at the top, as well as triggering sound effects taken directly from the film. The detonator is accompanied by a display plaque numbered "553/1000", a Master Replicas certificate of authenticity and other original paperwork, and a display box. It comes with the original Master Replicas packaging inside a black presentation box with navy foam lining. Batteries are not included. Dimensions (detonator): 7.5 cm x 6.5 cm x 6.5 cm (3" x 2.5" x 2.5") Contains electronics; see electronics notice in the Buyer's Guide.

**Estimate: £1,000 - 2,000**

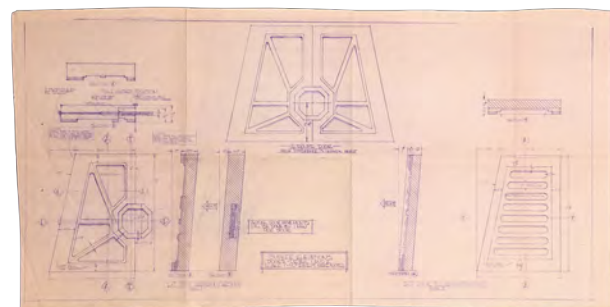

26.5 cm (10.5")

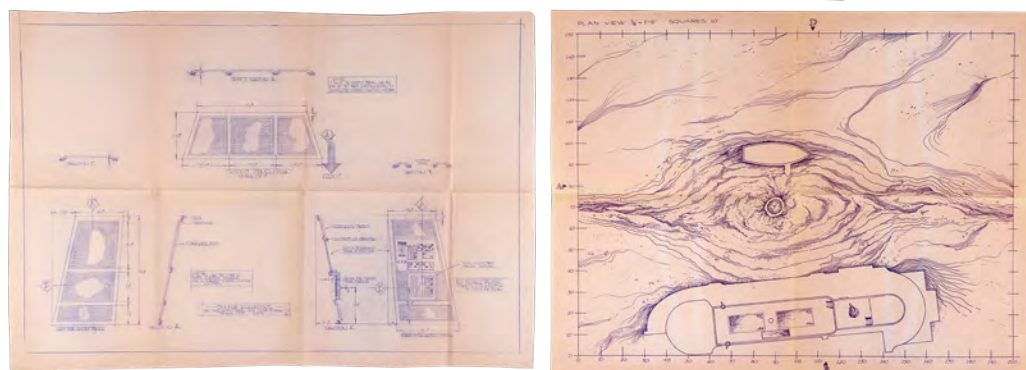

**1694**  
 Japanese B2 "Starfall" Poster m  
**Star Wars: Return Of The Jedi (1983)**

A Japanese B2 "Starfall" poster from the promotion of Richard Marquand's Star Wars: Return of the Jedi. Lucasfilm chose a number of internationally acclaimed artists to present a varied series of designs for the Worldwide advertising campaign of Return of the Jedi. The poster here is the Yamakatsu-issued Style B Japanese B2 by the prominent Star Wars artist Noriyoshi Ohrai. Titled "Starfall" by the artist, this design was not an official cinema poster but was sold exclusively in a small number of Japanese cinemas where the movie was playing. Due to printing difficulties, it was only available in very limited numbers and is extremely scarce. Dimensions: 72.5 cm x 51.5 cm (28.5" x 20.25")

**Estimate: £800 - 1,600**



72.5 cm (28.5")

**1695**  
 35mm Rebel Attack Deleted Scenes Reel Ω  
**Star Wars: Return Of The Jedi (1983)**

A 35mm reel featuring deleted scenes from the Rebel attack sequence of Richard Marquand's Star Wars: Return of the Jedi. After an adjustment to the film's post-production budget, the visual effects team at Industrial Light & Magic (ILM) deleted footage from the Rebel attack sequence to help the film meet its scheduled May 1983 theatrical release date. This black-and-white reel featuring the section of the Death Star attack footage numbered RA50 to RA78 was removed from a copy of the cut workprint of the film in August 1982. It remains spooled around a yellow plastic spool. Due to its age, some footage may be discoloured, and it should be handled with caution. Dimensions: 10.25 cm x 10.25 cm x 4 cm (4" x 4" x 1.5")

**Estimate: £600 - 1,200**

**1696**  
 Jabba the Hutt Arm m  
**Star Wars: Return Of The Jedi (1983)**

A Jabba the Hutt arm from the production of Richard Marquand's Star Wars: Return of the Jedi. Luke Skywalker (Mark Hamill) and his allies infiltrated Jabba's palace on Tatooine as they endeavoured to save Han Solo (Harrison Ford).

The arm is made of foam latex, and is an unfinished backup casting that was never painted. As a result of age, the arm exhibits fragility, with small pieces breaking off and cracks exhibiting. Some of the detached pieces accompany the arm. Dimensions: 62 cm x 30 cm x 21 cm (24.5" x 11.75" x 8.25")

**Estimate: £500 - 1,000**





**1697**  
**Jabba the Hutt Skin and Hand-drawn Concept Drawing** M  
**Star Wars: Return Of The Jedi (1983)**

A segment of Jabba the Hutt's skin and a hand-drawn concept drawing of the vile gangster from the production of Richard Marquand's Star Wars: Return of the Jedi. The skin is made of orange foam latex, while the drawing is rendered in pencil and black ink, and depicts Jabba reclining. The lot also includes a photograph of Jabba as he appeared in the film. The skin has dried up and crumbled over time, and no longer exists in a single piece. Dimensions: 26 cm x 21 cm (10.25" x 8.25")

**Estimate: £500 - 1,000**

**1699**  
**MPP 5x4 Micro Technical Camera, Flash Unit and Original Box** M  
**Star Wars: Original Trilogy (1977-1983)**

An MMP (Micro Precision Products) 5x4 micro technical camera, flash unit and original box. These vintage flash units were used on the productions of the original Star Wars trilogy as parts of Darth Vader's lightsaber, and as such are very sought-after items by collectors and replica enthusiasts.

The lot has a camera, an MPP flash unit, two lenses, a lens hood, various straps, and six DDS (Double Dark Slides) held in a fitted case. The entire set is held in its original wooden box, which has "Camera Ground S.92 Assembly" and "Ref W6/14A/4662" stencilled on the lid. The box and camera pieces have some wear from age and use. Dimensions (box): 24 cm x 59 cm x 41 cm (9.5" x 23.25" x 16.25")

Special shipping required; see special shipping notice in the Buyer's Guide.

**Estimate: £2,500 - 5,000**

Flash tube without reflector was the base component used for the Darth Vader lightsaber.



**1698**  
**"Revenge of the Jedi" Crew Jumper and Patch** M  
**Star Wars: Return Of The Jedi (1983)**

A "Revenge of the Jedi" crew jumper and patch from the production of Richard Marquand's Star Wars: Return of the Jedi. Both items display the film's original title, "Revenge of the Jedi", which was abandoned in favour of Return of the Jedi five months before the film's release. The jumper features white lettering on its chest, and the label inside is blank with no size markings. The iron-on patch features Yoda surrounded by a blue starfield. Light marks and minor pulls are present on the front of the jumper, and the patch's backing has cracked over time.

**Estimate: £300 - 600**



**1700**  
**Screening Invites, Lucite Star Crew Gift, Exhibitor's Book and Ephemera** Ω  
**Star Wars: Original Trilogy**

Screening invites, a lucite star crew gift, exhibitor's book, and ephemera from George Lucas' Star Wars trilogy. Lucasfilm distributed various crew gifts and other ephemera to its advertising partners throughout the promotional campaigns for the films' theatrical runs. This lot consists of a white polyester Star Wars graphic shirt (Size M); a black metal Star Wars branded pen; a Ralph McQuarrie Christmas card dated 1978 featuring C3PO, R2D2, and the printed autograph of Gary Kurtz; a branded notepad sheet; a blue and white embroidered Star Wars patch; a Waldorf School Benefit screening invite and information card; a screening invite at the Academy Award Theatre; a black printed 20th Century Fox film catalogue featuring 26 films for 1976 and newspaper article; an early Ralph McQuarrie design film print; a brown vinyl 20th Century Fox exhibitor's book with a yellow legal notepad and wooden pencil; and a clear acrylic lucite star with Star Wars engraved on the front. This lot exhibits discolouration on the design print and newspaper, as well as loose pages in the catalogue. Dimensions: (largest) 30.5 cm x 44.5 cm x 0.75 cm (12" x 17.5" x 0.25")

**Estimate: £2,000 - 4,000**



George Lucas title page autograph detail

**1701**  
**George Lucas and ILM-Autographed The Art of Special Effects Book** Ω  
**Industrial Light & Magic (ILM)**

A copy of Thomas G. Smith's Industrial Light & Magic: The Art of Special Effects autographed by George Lucas and various ILM personnel. In addition to Lucas' signature on the title page, the book features the signatures such luminaries as Michael Gleason, Chrissie England, Jim Morris, Tom Bertino, Selwyn Eddy, Pat Sweeney, Bill George, Charles Bailey, Marty Brenneis, Lorne Peterson, Steve Gawley, Paul Huston, Ken Ralston, Dennis Muren, Caroleen "Jett" Green, Wes Takahashi, Bruce Vecchitto, and more than two dozen others. The cover exhibits minor wear from age and handling. Dimensions: 31.5 cm x 26.25 cm x 3.5 cm (12.5 x 10.5" x 1.5")

**Estimate: £3,000 - 6,000**

**1702**  
**Set of Three Hand-drawn Ralph McQuarrie Sparky Concept Sketches** Ω  
**Star Wars: Panasonic Commercial (1988)**

Three Sparky concept sketches hand-drawn by renowned concept illustrator Ralph McQuarrie for a series of Star Wars-themed Panasonic commercials. Beginning in 1988, franchise creator George Lucas appeared with R2-D2 and a new creation, a genius talking robot named Sparky, in ads promoting Panasonic's high-tech Maclord videocassette players. At the specific request of Panasonic president Masaharu Matsushita, Sparky was designed by McQuarrie, whose concept designs for the original trilogy resulted in some of the most iconic and futuristic characters, sets, and technologies in modern science-fiction. This set consists of three sheets of vellum, each featuring a concept sketch of Sparky as seen from the front or left side rendered in graphite and watercolour. One sketch is signed by McQuarrie, while another is annotated "3 U D" and taped to backing paper. The sketches all exhibit smudging and bent corners. Dimensions: (each) 21.75 cm x 28 cm (8.5" x 11") Sold without copyright; see notice in the Buyer's Guide.

**Estimate: £1,000 - 2,000**

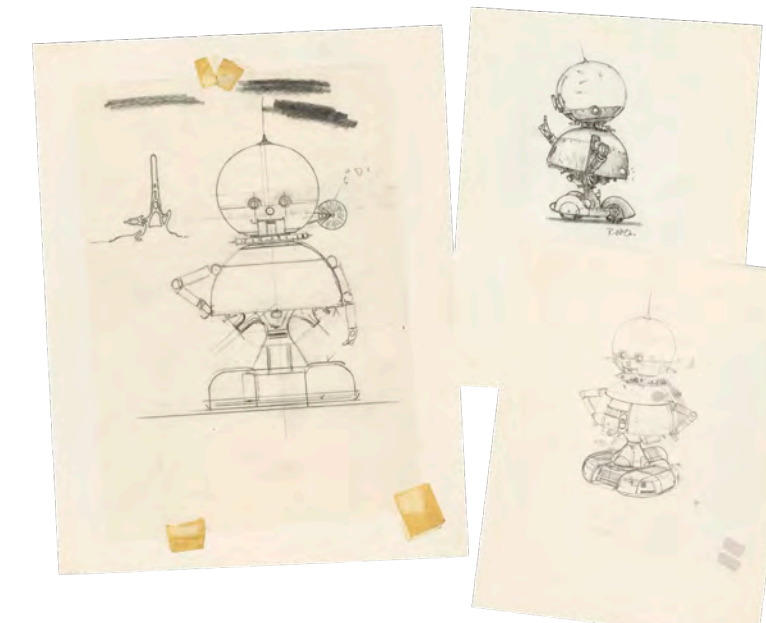

**1703**  
**Script and Production Ephemera** †  
**Star Wars: The Phantom Menace (1999)**

A script and production ephemera from the production of George Lucas' Star Wars: The Phantom Menace. This is the "Third Draft" script, and features the film's working title, "The Beginning". The script is dated "May 13, 1997" and "Revised June 2, 1997" and is credited to George Lucas. It is 119 pages long, each page watermarked with the number 61, and includes blue pages, which feature revisions made July 10, 1997; pink pages, which feature revisions made July 18, 1997; and yellow pages, which feature revisions made August 25, 1997. Included with the script are shooting schedules, scene breakdowns, notes from meetings with George Lucas and concept illustrations of various characters, including Anakin Skywalker (Hayden Christensen). The script and ephemera are bound in a black plastic folder. Dimensions: 32 cm x 25 cm x 7 cm (13" x 10" x 3")

**Estimate: £800 - 1,600**

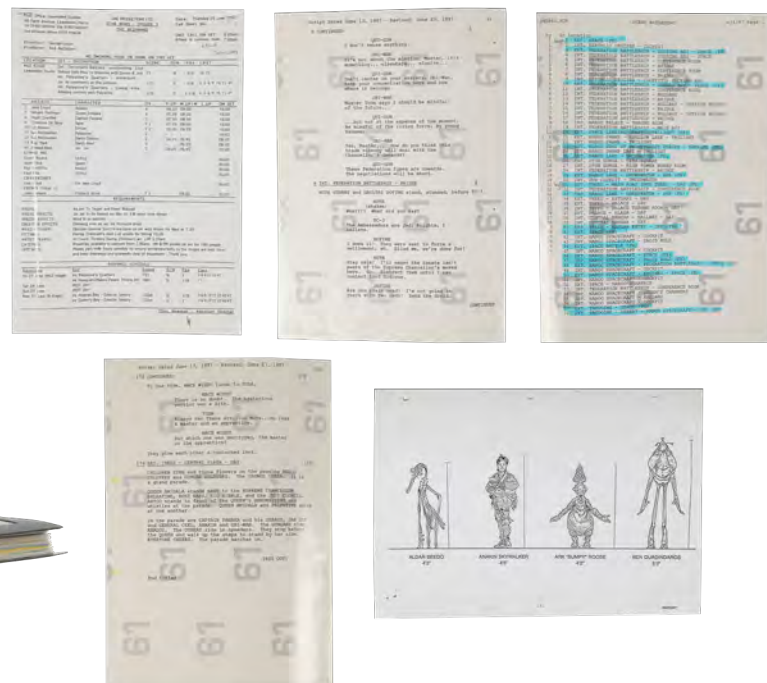

**1704**  
**ANOVOS Death Trooper Statue** †  
**Rogue One: A Star Wars Story (2016)**

A Death trooper statue from the promotion of Gareth Edward's Rogue One: A Star Wars Story. Death troopers were elite stormtroopers serving the Galactic Empire and often escorted Director Krennic (Ben Mendelsohn) as a protection detail. This 1:1 scale statue is made primarily of fibreglass and resin. The blaster rifle can be removed from the statue. The statue was made by Anovos Studios and stands on a black base. Dimensions: 66 cm x 85 cm x 195 cm (26" x 33.5" x 76.75") Special shipping required; see special shipping notice in the Buyer's Guide.

**Estimate: £3,000 - 6,000**



195 cm (76.75")



"Kenny Baker R2-D2" autograph detail



**1705**  
**Kenny Baker-Autographed and Gifted Crew Jacket** †  
**Star Wars: The Phantom Menace (1999)**

A gifted crew jacket, autographed by Kenny Baker, from the production of George Lucas' Star Wars: The Phantom Menace. Baker played the droid R2-D2. This black bomber-style jacket features a fur collar and gold embroidery, which reads "Cast and Crew 1997" across the left breast and "Star Wars Episode I" across the back. Baker has autographed the right breast in white ink with "Kenny Baker - R2-D2". Included with the lot is an issue of a Comics International magazine which has the information for the competition in which the jacket was originally won on page 23. The autographs in this lot have been professionally authenticated by expert Garry King; see notice in the Buyer's Guide.

**Estimate: £600 - 1,200**



Extremely limited gold-plated Commemorative Edition lightsaber hilt

**1706**  
**Master Replicas Light-up Commemorative Edition Gold-plated Darth Vader Force FX Lightsaber Replica** †  
**Star Wars: Original Trilogy**

A light-up, gold-plated Commemorative Edition lightsaber based on Darth Vader's (David Prowse) from George Lucas' original Star Wars trilogy. To commemorate the sale of more than one million FX lightsabers, Lucasfilm licensee Master Replicas produced an extremely limited number of Vader lightsabers with gold-plated hilts. This lightsaber originated with one of Master Replicas' manufacturers. It features a polycarbonate blade designed to illuminate red via a button on the gold-plated hilt, which conceals a battery pack. Also included are the original box and a "Star Wars"-branded bag containing instructions, batteries, and a "Revenge of the Sith" trading card. The box has been opened, and it exhibits wear throughout from previous shipping. Dimensions: 114.5 cm x 7.75 cm x 10.25 cm (45" x 3" x 4") Contains electronics; see electronics notice in the Buyer's Guide.

**Estimate: £2,500 - 5,000**



**1707**  
**Unfinished Ki-Adi-Mundi Lightsaber Hilt** †  
**Star Wars: Attack Of The Clones (2002)**

An unfinished Ki-Adi-Mundi (Silas Carson) lightsaber hilt from the production of George Lucas' Star Wars: Attack of the Clones. Ki-Adi-Mundi employed his lightsaber during the battle on Geonosis. The saber is made of resin and painted to look like metal, though the light details on the saber are unpainted. It exhibits some wear from age and use. Dimensions: 26 cm x 4 cm x 5 cm (10.25" x 1.5" x 2")

**Estimate: £1,000 - 2,000**



**1708**  
**Obi-Wan Kenobi's (Ewan McGregor) Rehearsal Lightsaber** †  
**Star Wars: Revenge Of The Sith (2005)**

Obi-Wan Kenobi's (Ewan McGregor) rehearsal lightsaber from George Lucas' Star Wars: Revenge of the Sith. Jedi Master Kenobi carried and used his lightsaber in various scenes throughout the saga, notably during a duel on the fiery planet of Mustafar with his former apprentice Anakin Skywalker (Hayden Christensen), by then known as Darth Vader. This lot consists of a black and silver-colour metal and resin lightsaber hilt with a rounded pommel cap inset with a threaded metal rod, as well as a green carbon fibre blade. This rehearsal lightsaber's hilt is in the style carried by Kenobi in The Phantom Menace and Attack of the Clones, as it was originally planned for Kenobi to transition to his A New Hope hilt mid-film, but it was ultimately decided to instead have Kenobi wielding his updated lightsaber from the beginning of the film. The hilt and blade exhibit nicking and scuffing throughout from production and handling. Dimensions: 124.5 cm x 4.5 cm x 4.5 cm (49" x 1.75" x 1.75")

**Estimate: £2,500 - 5,000**



**1709**  
 ILM Chewbacca Statue m  
**Star Wars:**  
**Revenge Of The Sith (2005)**

An ILM Chewbacca statue from the production of George Lucas' Star Wars: Revenge of the Sith. Industrial Light and Magic created a limited number of Chewbacca figures as gifts for studio executives who worked on the film. The highly detailed figure is made of resin and painted to appear bronze. It is presented on a black pedestal base featuring the film title, with an ILM logo sticker adhered to the front and a removable glass dome cover. The top surface of the display pedestal exhibits white markings and scuffs. Dimensions: 43.5 cm x 22 cm x 22 cm (17.25" x 8.75" x 8.75")

**Estimate: £700 - 1,400**



**1710**  
 Master Replicas  
 Special Ops Trooper Helmet m  
**Star Wars:**  
**Revenge Of The Sith (2005)**

A Master Replicas blue 'Special Operations' Clone trooper helmet as seen in George Lucas' third prequel Star Wars: Revenge of the Sith. Clones stationed on Coruscant wore blue striped helmets whilst perpetrating the great Jedi purge. Although none of these helmets were physically used in the movie, Master Replicas were granted access to the digital character files at Lucasfilm, allowing them to accurately recreate the impressive piece of armour. The helmet is made from fibreglass, complete with padding inside and is accompanied by a certificate of authenticity and its original packaging. The helmet exhibits a few minor scuffs.

Dimensions: 30 cm x 26.5 cm x 33 cm (11.75" x 10.5" x 13")

**Estimate: £500 - 1,000**



Back of passes detail

**1711**  
 Natalie Portman  
 and Ewan McGregor  
 Leavesden Studios Passes m  
**Star Wars:**  
**Prequel Trilogy (1999-2005)**

Natalie Portman and Ewan McGregor's Leavesden Studios passes from the production of George Lucas' Star Wars prequel trilogy. Leavesden Studio is based in Hertfordshire, UK, and was also the filming base for the Harry Potter series. The plastic ID cards feature McGregor and Portman's portraits and names. Dimensions (each): 5.5 cm x 8.5 cm (2.25" x 3.25")

**Estimate: £1,000 - 2,000**

**1712**  
 Han Solo (Harrison Ford)  
 and Other Prototype Oversize Toys m  
**Star Wars: The Force Awakens (2015)**

Han Solo (Harrison Ford) and other oversize prototype toys from the promotion of J.J. Abrams' Star Wars: The Force Awakens. These prototypes were for toys that never went into production of the legendary smuggler Han Solo, Rebel pilot Temmin "Snap" Wexley (Greg Grunberg), and space pirates Sidon Ithano (Cavin Cornwall) and Quiggold (Matthew Wood). The Han and Snap toys are cast in dark grey resin and retain a rough, unfinished texture, while the Sidon and Quiggold toys are cast in light grey resin with a smooth finish. The prototypes do not move, but are constructed with joints where the limbs would pivot in the final version. Each toy stands on a wooden display board. There is little wear from use, with some minor scratches and imperfections from the casting process. Dimensions (largest): 19 cm x 29 cm x 45 cm (7.5" x 11.5" x 17.75")

**Estimate: £4,000 - 8,000**



170 cm (67")

**1713**  
 ANOVOS First Order Stormtrooper Statue m  
**Star Wars: The Force Awakens (2015)**

A life-size First Order Stormtrooper statue from the promotion of J.J. Abrams' Star Wars: The Force Awakens. Stormtroopers were the infantry for the evil First Order. This 1:1 scale statue is made primarily of resin and fibreglass and features such accessories as a blaster and a belt. The statue was made by Anovos Studios and stands on a black base. It has some minor chips and markings. Dimensions: 120 cm x 76 cm x 170 cm (47.25" x 30" x 67") Special shipping required; see special shipping notice in the Buyer's Guide.

**Estimate: £3,000 - 6,000**



183 cm (72")

**1714**  
 Propshop Rey Staff Replica m  
**Star Wars:**  
**The Force Awakens (2015)**

A Propshop Rey staff replica staff from J.J. Abrams' Star Wars: The Force Awakens. Propshop, the industry prop and set decoration fabricator that created many props for The Force Awakens, released limited-edition prop replicas in partnership with Disney and Lucasfilm. The pieces were made from original 3D scan data from the production to ensure utmost accuracy. Used in marketing events, the 3D-printed staff is painted grey to resemble aged metal and features linen and leather wraps that have been distressed to simulate age and a brown woven cotton strap. Also included is one original Propshop crate, a grey metal medallion emblazoned with "Star Wars," a cleaning cloth, and one stand. The staff exhibits some scuffing to its finish. Dimensions: 183 cm x 7.75 cm x 7.75 cm (72" x 3" x 3") Additional Provenance: Certificate of Authenticity from Propshop. Special shipping required; see notice in the Buyer's Guide.

**Estimate: £3,000 - 6,000**

**1715**  
Propshop Chewbacca  
Bowcaster Replica  $\Omega$   
**Star Wars:**  
**The Force Awakens (2015)**

A Propshop Chewbacca bowcaster replica from J.J. Abrams' Star Wars: The Force Awakens. The loyal Wookiee, Chewbacca (Peter Mayhew), wielded his signature laser crossbow against representatives of the First Order. Propshop, the industry prop and set decoration fabricator that created many props for the film, released only 500 made-to-order replicas of Chewie's bowcaster in partnership with Disney and Lucasfilm. Each was made from original 3D scans of the original production bowcaster to ensure the utmost accuracy. This black bowcaster is constructed from high-density resin with metal and acrylic elements, including a binocular scope, circular side greebles, and a pressable trigger. Also included is a custom display stand printed with the film's production logo. It exhibits visible scuffing on its butt and barrel from handling. Dimensions: 80 cm x 77.5 cm x 23 cm (31.5" x 30.5" x 9")



77.5 cm (30.5")



**Estimate: £3,000 - 6,000**



**1716**  
Prototype Stormtrooper Helmet  $\mu$   
**Star Wars: The Force Awakens (2015)**

A prototype stormtrooper helmet from the production of J.J. Abrams Star Wars: The Force Awakens. This piece was developed early in the production by the film's propmakers, Propshop, as part of a show and tell with director J.J. Abrams. It is a heavily distressed stormtrooper helmet and has tinted visors in the eye holes, a rubber brow trim, grey vent inserts on the cheekbones, ear protectors and two black plastic aerator tips with a metal mesh filter on the chin. Dimensions: 27.5 cm x 28 cm x 28 cm (10.75" x 11" x 11")

**Estimate: £1,500 - 3,000**



**1717**  
Propshop Melted Darth Vader Helmet Replica  $\Delta$   
**Star Wars: The Force Awakens (2015)**

A limited edition Propshop replica of the melted Darth Vader helmet from J.J. Abrams' Star Wars: The Force Awakens. In the film, Kylo Ren (Adam Driver) brooded over the charred remains of Lord Vader's (David Prowse) helmet. Propshop, the industry prop and set decoration fabricator who created many props for The Force Awakens, released only 500 made-to-order, 3D-printed replicas of the melted helmet in partnership with Disney and Lucasfilm. Made from original 3-D scan data from the production to ensure accuracy, this helmet is constructed of a range of proprietary synthetic materials, hand-painted in Vader's signature charcoal-black, sanded and affixed with metal details near the damaged breathing apparatus. Also included is a display stand with a plaque and a certificate of authenticity medal. Dimensions: 45.75 cm x 30 cm x 41 cm (18" x 11.75" x 16.25")

**Estimate: £1,500 - 3,000**

No lot 1718



Teardrop-shaped, bronze-colour metal medallion with engraved planet and stars detail



**1719**  
Propshop Replica Kylo Ren Helmet with Stand  $\Delta$   
**Star Wars: The Force Awakens (2015)**

A limited edition Propshop replica Kylo Ren (Adam Driver) battle-worn helmet from J.J. Abrams' Star Wars: The Force Awakens. Propshop, the industry prop and set decoration fabricator who created many props for The Force Awakens, released made-to-order, 3D-printed helmet replicas in partnership with Disney and Lucasfilm. The pieces were made from original 3D scan data from the production to ensure the utmost accuracy, and this helmet is constructed of a range of proprietary synthetic materials. It has a padded lining and a black mesh insert on the inside of the visor. The helmet has been expertly hand-painted, with silver-coloured inlay detailing and intentional weathering applied. The lot comes with a black plastic display stand with a plaque. An authenticity medallion from Propshop also accompanies the lot. The helmet exhibits wear in the form of the outer decorative line being slightly detached from the helmet on the right side near the bottom. Dimensions (displayed): 33 cm x 23.25 cm x 50 cm (13" x 9.25" x 19.75")

**Estimate: £1,000 - 2,000**

**1720**  
Rose Tico's (Kelly Marie Tran) Necklace  $\Omega$   
**Star Wars: The Last Jedi (2017)**

Rose Tico's (Kelly Marie Tran) necklace from Rian Johnson's Star Wars: The Last Jedi. Rose and her sister Paige Tico (Veronica Ngo) both wore necklaces that represented their homeworld in the Otomok system, and Rose's necklace was later used by DJ (Benicio del Toro) to unlock a door aboard the First Order flagship, the Supremacy. This necklace consists of a teardrop-shaped, bronze-colour metal medallion with a planet and stars engraved on it and a silver-colour metal wire necklace. It exhibits some scratching and signs of wear in addition to subtle production-applied distressing.

**Estimate: £2,000 - 4,000**



**1721**  
Set of Casino Chips †Δ  
**Star Wars: The Last Jedi (2017)**

A set of casino chips from Rian Johnson's sci-fi adventure sequel Star Wars: The Last Jedi. On the planet of Cantonica, betting chips were seen on the gambling tables of Canto Bright Casino. The chips vary in size and are made of resin, with the casino crest engraved into each surface.  
Dimensions: (largest chip) 6 cm x 6 cm x 1 cm (2.5" x 2.5" x 0.25")

**Estimate: £1,000 - 2,000**



5 cm (2")

**1722**  
Magnetic Bomb †Δ  
**Star Wars: The Last Jedi (2017)**

A magnetic bomb from Rian Johnson's sci-fi adventure sequel Star Wars: The Last Jedi. DJ (Benicio Del Toro) ransacked the storage units of a spaceship he stole, discovering magnetic bombs inside a drawer. The bomb is made of resin.  
The Dimensions: 5 cm x 5 cm x 5 cm (2" x 2" x 2")

**Estimate: £500 - 1,000**



42 cm (16.5")

**1723**  
Mark Hamill-Autographed Mini German Poster †Δ  
**Star Wars: The Last Jedi (2017)**

A mini German poster from the promotion of Rian Johnson's Star Wars: The Last Jedi. Luke Skywalker actor Mark Hamill has signed the poster with his autograph in black marker. This is the Advance style designed by Creative Arts Agency LA. Dimensions: 42 cm x 29.75 cm (16.5" x 11.75") The autographs in this lot have also been professionally authenticated by expert Garry King; see notice in the Buyer's Guide.

**Estimate: £300 - 600**

**1724**  
Poe Dameron's (Oscar Isaac)  
Light-up Flashlight †Δ  
**Star Wars:  
The Rise Of Skywalker (2019)**

Poe Dameron's (Oscar Isaac) light-up flashlight from J.J. Abrams' Star Wars: The Rise of Skywalker. Poe carried and used his flashlight after falling through a sinkhole on the desert planet Pasaana. This flashlight is made of a metal and grey painted resin base with engraved black acrylic detailing along the sides and a metal loop. The flashlight is functional when a small item (such as a paperclip or safety pin) is inserted in the opening on the bottom, illuminating the small LED light on the other end. This lot exhibits production-added distressing, scuffing, and chipped paint. Dimensions: 24.25 cm x 6.5 cm x 6.5 cm (9.5" x 2.5" x 2.5") Contains electronics; see electronics notice in the Buyer's Guide.

**Estimate: £2,000 - 4,000**



Pommel cap detail



**1725**  
ICONS Obi-Wan Kenobi Lightsaber Replica †Δ  
**Star Wars: The Complete Saga**

An ICONS replica Obi-Wan Kenobi (Alec Guinness) lightsaber from the promotion of George Lucas' Star Wars film series. ICONS created licensed Star Wars replicas based on the original props in the Skywalker Ranch Archives. A production run of 10,000 Obi-Wan lightsabers was planned, but only about 6,000 were ultimately produced. Numbered "418/10,000", this lightsaber is constructed from steel, aluminium and hard-moulded plastic, with "Lucasfilm Ltd./Icons 1997" engraved on the bottom. Also included is a certificate of authenticity with a custom display stand featuring a plaque engraved "Obi-Wan Lightsaber". Detailed care instructions are also included. Dimensions: 30 cm x 24 cm x 43 cm (11" x 9.5" x 17")

**Estimate: £800 - 1,600**



**1726**  
Costume FX 2013 - 2019 Crew Gift Medallion †Δ  
**Star Wars: Various Productions**

A medallion gifted to members of the costume department who worked on Star Wars films between the years 2013 and 2019. Suspended on a green grosgrain ribbon, the bronze-coloured medallion features the Star Wars logo engraved above a circular design, which displays embossed text reading "Costume, Costume FX, 2013-2019", ringed by the production titles: "Episode VII, Rogue One, Episode VIII, Solo, Episode IX". The back of the medal has an embossed design replicating the Medal of Bravery seen in A New Hope and again in The Rise of Skywalker, and comes in a black presentation box. Also included is a note from "Dave" honouring the work of the recipients.  
Dimensions (in box): 17.5 cm x 12.5 cm x 2 cm (7" x 5" x 0.75")

**Estimate: £800 - 1,600**



**1727**  
Col. Jack O'Neil's (Kurt Russell)  
Navy Blue Costume Ω  
**Stargate (1994)**

Col. Jack O'Neil's (Kurt Russell) costume from Roland Emmerich's Stargate. O'Neil wore his navy blue suit while he oversaw the classified project relating to the stargate. This costume consists of a navy blue wool suit jacket; a light blue cotton button-up shirt; a navy blue tie; a navy blue webbed belt with metal hardware; navy blue wool trousers; a pair of black cotton socks, and black leather combat boots. The jacket is hand-marked "O'Neil" in white on the interior pocket and the boots are hand-marked "O'Neil" on the interior in white as well. This lot exhibits some discolouration on the blue shirt neckline.

**Estimate: £2,000 - 4,000**

**1729**  
Light-up Asuran Replicator Stunner and Holster +  
**Stargate Atlantis (T.V. Series, 2004-2009)**

A light-up Asuran Replicator stunner and holster from the television show Stargate: Atlantis. Asuran Replicators used their stunners during the third and fourth seasons of the show to incapacitate or kill their enemies. The pistol is made of metal with foam padding around the grip. The underside of the barrel can be pulled down, revealing a faux crystal made of resin. A small switch near the trigger on the underside of the barrel illuminates the crystal and a strip of lights down each side. The holster is made of brown leather and has a loop to attach it to a belt. An elasticated strap secures the pistol in place. There is some minor wear on both pieces, including scuffing and scratches, and there is a noticeable dent in the metal at the back of the stunner. Dimensions (stunner): 25 cm x 3.5 cm x 13 cm (9.75" x 1.5" x 5") Contains electronics; see electronics notice in the Buyer's Guide.

**Estimate: £3,000 - 6,000**

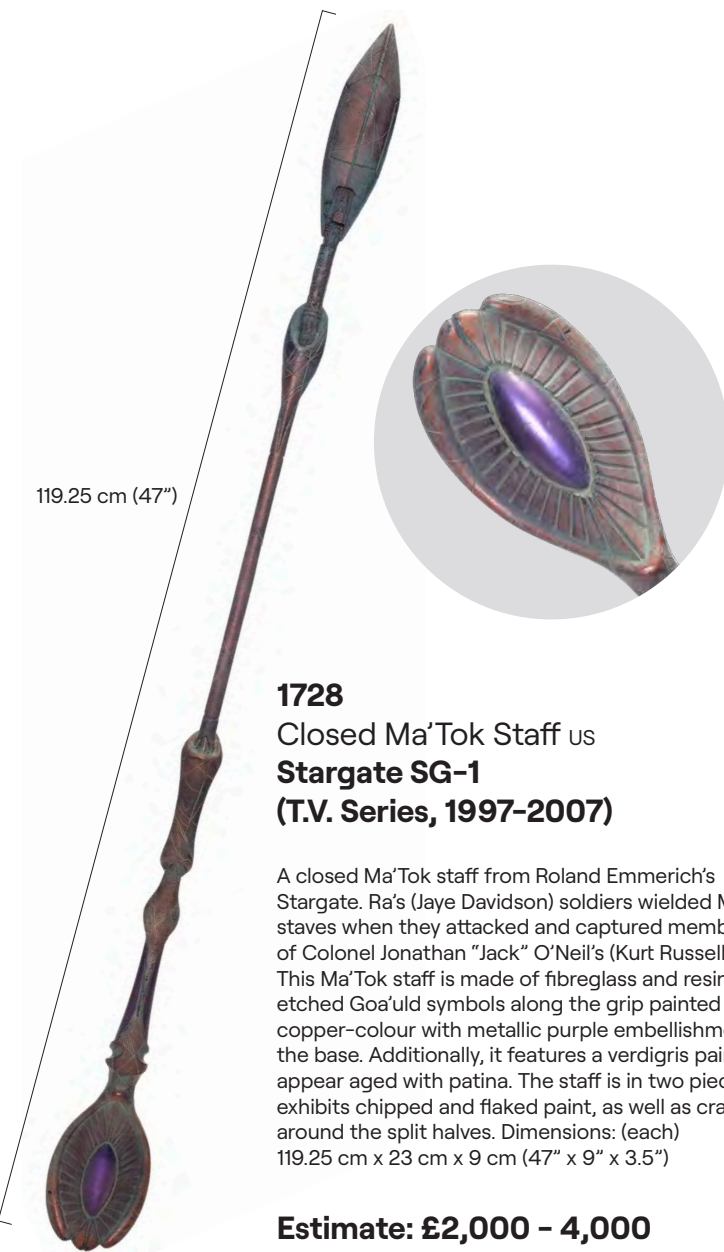

119.25 cm (47")

**1728**  
Closed Ma'Tok Staff us  
**Stargate SG-1**  
**(T.V. Series, 1997-2007)**

A closed Ma'Tok staff from Roland Emmerich's Stargate. Ra's (Jaye Davidson) soldiers wielded Ma'Tok staves when they attacked and captured members of Colonel Jonathan "Jack" O'Neil's (Kurt Russell) unit. This Ma'Tok staff is made of fibreglass and resin with etched Goa'uld symbols along the grip painted a copper-colour with metallic purple embellishments in the base. Additionally, it features a verdigris paint to appear aged with patina. The staff is in two pieces. It exhibits chipped and flaked paint, as well as cracking around the split halves. Dimensions: (each) 119.25 cm x 23 cm x 9 cm (47" x 9" x 3.5")

**Estimate: £2,000 - 4,000**



Holster is made of brown leather



**1730**  
Screen-matched Vanir Asgard Helmet +  
**Stargate Atlantis - The Lost Tribe (2008)**

A screen-matched Vanir Asgard helmet from the television series Stargate Atlantis. Vanir soldiers took Dr Daniel Jackson (Michael Shanks) and others hostage as they sought to use the Attero device to wipe out the Wraiths in the Season Five episode "The Lost Tribe". The helmet matches to the one worn by the Vanir whom Jackson pleads not to use the device, through the scratches and battle damage on the dome. The helmet is made of fibreglass resin with an acrylic eyepiece. Two wires and a button are present inside where the lights on each side of the head were previously powered. "6" is handwritten on tape inside the dome, and two pieces of faux leather cover the back of the neck. Dimensions: 34 cm x 26 cm x 29 cm (13.5" x 10.25" x 11.5") Contains electronics; see electronics notice in the Buyer's Guide.

**Estimate: £2,500 - 5,000**

**1732**  
Corvette Transport  
and TAC Fighter Model Miniatures Ω  
**Starship Troopers (1997)**

A model miniature Corvette Transport and TAC fighter from Paul Verhoeven's Starship Troopers. Fleet pilots Carmen Ibanez (Denise Richards) and Zander Barcalow (Patrick Muldoon) worked on the Rodger Young, a Corvette Transport ship, during the Battle of Klendathu. TAC fighters were the primary combat aircraft of the United Citizen Federation Fleet. Both miniatures are made of resin and hand-painted to resemble metal. The TAC fighter has had one of its vertical stabilisers at the rear replaced since production. Both pieces come with custom-made displays. Dimensions (Corvette Transport): 15 cm x 4.5 cm x 4 cm (6" x 1.75" x 1.5")

**Estimate: £4,000 - 8,000**



**1731**  
Katrina McIntire's (Blake Lindsley)  
Screen-matched Mobile Infantry M-3 Tactical Helmet Ω  
**Starship Troopers (1997)**

Katrina McIntire's (Blake Lindsley) screen-matched mobile infantry M-3 tactical helmet from Paul Verhoeven's adventure sci-fi Starship Troopers. Soldiers of the Federation wore helmets during their war against the Arachnids. This helmet matches the one worn on screen by its distinctive holes and scuffs that make it appear battle-worn. The helmet is made of fibreglass with a foam pad lining, rubber cheek guards and a chin strap. Press studs allow the chin strap to be easily detached. The helmet is finished in dark grey paint and marked "Katrina" internally in black ink. The foam inner lining is breaking up inside the helmet due to age. Dimensions: 27.5 cm x 25 cm x 23 cm (10.75" x 9.75" x 9")

**Estimate: £800 - 1,600**





no lot 1733



**1734**  
Mobile Infantry Stunt  
(Tanner Gill) Costume  $\Omega$   
**Starship Troopers (1997)**

A Mobile Infantry stunt (Tanner Gill) uniform from Paul Verhoeven's *Starship Troopers*. Mobile Infantry troopers wore their uniforms throughout their planet-hopping campaign against the alien Arachnids. Originating from stunt performer Tanner Gill, this lot consists of a neoprene neck seal; foam-rubber chest armour marked "ADAM D 8"; a grey polyester zip-up jacket (Size 46 to 48 X-Large) marked Tanner; a pair of grey padded trousers (Size L 36-38); a pair of black leather and nylon gloves marked "XL"; a leg holster featuring a metal throwing knife; and a pair of Adidas® boots (U.K. size 11). This lot exhibits minor discolouration and production-added distress.

**Estimate: £1,500 - 3,000**



**1735**  
Tanner Gill (Double) Mobile Infantry  
M-3 Tactical Helmet  $\Omega$   
**Starship Troopers (1997)**

A Tanner Gill (Double) Mobile Infantry M-3 tactical helmet from Paul Verhoeven's *Starship Troopers*. Mobile Infantry troopers wore their combat uniforms and armour throughout their planet-hopping campaign against the alien Arachnids. Originating from stunt performer Tanner Gill, this lot consists of a hero-grade futuristic M-3 Tactical helmet is constructed of hand-painted grey fibreglass with interior foam padding, rubber details on the cheeks and visor, and a leather chin guard marked "Tanner - DBL Rascak" [sic]. This helmet exhibits production-added distress, as well as deteriorating leather on the chin strap.

**Estimate: £1,200 - 2,400**



**1736**  
Stunt Morita MK I Rifle  $\Omega$   
**Starship Troopers (1997)**

A stunt Morita MK I rifle from Paul Verhoeven's *Starship Troopers*. Mobile Infantry carried Morita rifles as they battled ferocious Arachnids. Cast from a hero version of the firearm, this stunt rifle is made of foam rubber with an internal metal armature. The main body has been finished in dark green with black components and a silver-colour magazine. It features intricate detailing on the receiver, magazine, and grip as well as a black nylon sling attached via metal clips to the left side. It exhibits grime from production, and the magazine is splitting from the body. Dimensions: 101.75 cm x 29.25 cm x 6.5 cm (40" x 11.5" x 2.5") Ownership may be restricted in some countries; see replica firearm notice in Buyer's Guide.

**Estimate: £1,200 - 2,400**



**1737**  
Set of Fortress of Solitude Crystals  $\pm\Delta$   
**Superman (1978)**

A set of Fortress of Solitude crystals from Richard Donner's superhero film *Superman*. Elaborate crystals featured in Superman's (Christopher Reeve) otherworldly Arctic retreat to the Fortress of Solitude when he summoned the consciousness of his father Jor-El (Marlon Brando). Crystals also appeared on the planet Krypton and in the sequel. This set includes two long and two shorter crystals, each presenting an angular, shard-like shape. The crystals are made of transparent resin and feature uneven pointed ends. The largest crystal exhibits adhesive and gold-colour residue from production use. Dimensions (largest crystal): 50 cm x 2.5 cm x 2.5 cm (19.75" x 1" x 1")

**Estimate: £2,000 - 4,000**



**1738**  
Lex Luthor's (Gene Hackman) Cravat  $m$   
**Superman (1978)**

Lex Luthor's (Gene Hackman) cravat from Richard Donner's superhero film *Superman*. The villainous Luthor wore his cravat during the film's finale, as he finally came face-to-face with Superman (Christopher Reeve) and enacted his plan to sink the western United States. The white-and-navy blue Odil St Germain cravat features a square pattern incorporating "L"s throughout. It has some minor staining.

**Estimate: £2,000 - 4,000**

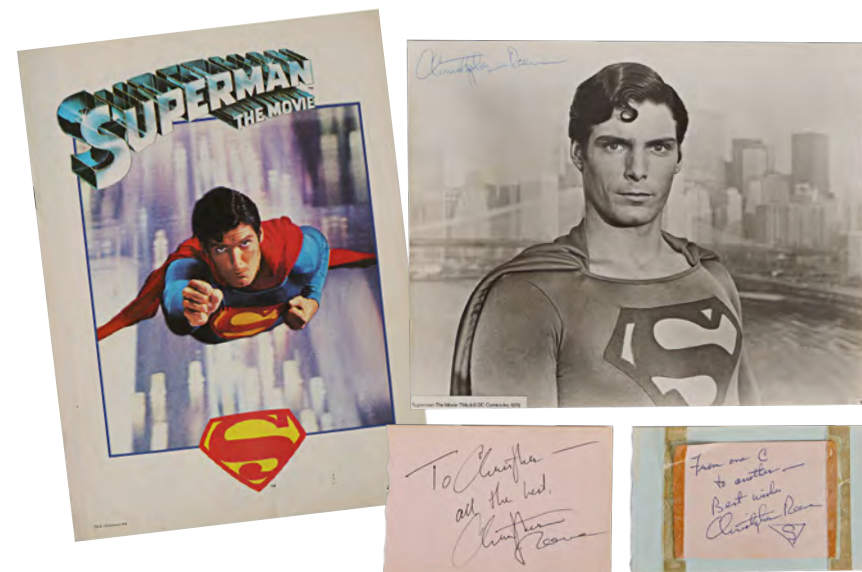

**1739**  
"Oils Well That Ends Well! Superman Super Again!" and "White House Surrenders" Newspapers m  
**Superman II (1980)/Superman III (1983)**

Two Daily Planet newspapers from Richard Lester's superhero sequels, Superman II and Superman III. The "White House Surrenders" newspaper is from the second instalment and is connected to Zod's (Terence Stamp) success in forcing the President (E.G. Marshall) to surrender. The "Oils Well That Ends Well! Superman Super Again!" newspaper is from the third instalment, with its content related to the sequence where Superman (Christopher Reeve) rectifies the oil spill. The newspapers exhibit tears and staining.  
Dimensions (one paper): 60 cm x 45 cm x 0.5 cm (23.5" x 17.75" x 0.25")

**Estimate: £1,000 - 2,000**



**1740**  
Set of Three Christopher Reeve Autographs and a Promotional Booklet m  
**Superman (1978)**

Three Christopher Reeve autographs and a promotional booklet from the promotion of Richard Donner's Superman. Included are an autographed photograph of Reeve in character as Superman, two pages with handwritten inscriptions from Reeve—"From one C to another—Best wishes Christopher Reeve" and "To Christopher—all the best, Christopher Reeve"—and a promotional booklet from the film's release. The pages have been removed from a larger album and have some edgewear and discolouration. Dimensions (photo): 20.5 cm x 25.5 cm (8" x 10") The autographs in this lot have been professionally authenticated by expert Garry King; see notice in the Buyer's Guide.

**Estimate: £1,000 - 2,000**

**1741**  
Final Screenplay m  
**Superman (1978)**

A final screenplay from the production of Richard Donner's superhero film Superman. This script - credited to David Newman, Leslie Newman and Robert Benton - is called "Superman (Part 1)", dated "July 1976" and is 230 pages long. "Superman" is handwritten on the page edges, and it is bound with metal fasteners between light-blue card covers. The script has some creasing and minor discolouration. Dimensions: 28 cm x 22 cm x 3 cm (11" x 8.75" x 1.25")

**Estimate: £500 - 1,000**

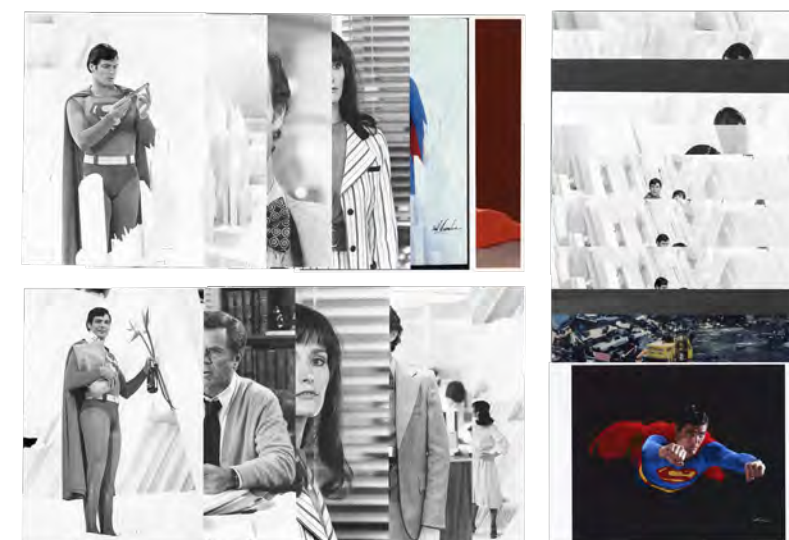
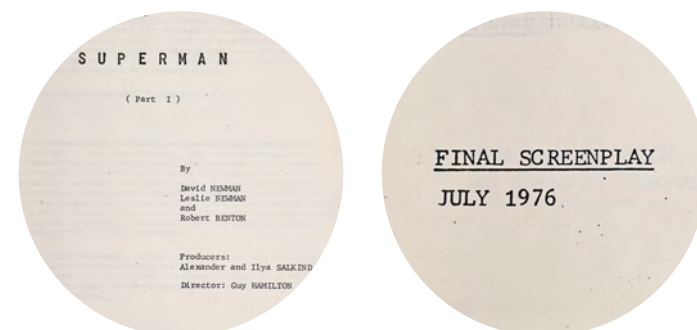

**1742**  
Keith Hamshere Collection:  
Production Photos and Promotional Stills m  
**Superman II (1980)**

A collection of photographs from the production and promotion of Richard Lester's Superman II. This lot comes from the personal collection of renowned stills photographer Keith Hamshere. Included are 22 photos: 18 large black-and-white photographs and four smaller colour photographs. They feature Christopher Reeve (Superman), Margot Kidder (Lois Lane), Jackie Cooper (Perry White) and Marc McClure (Jimmy Olsen). The photos include headshots, candid behind-the-scenes shots, and stills. Dimensions (largest): 40.5 cm x 30.5 cm (16" x 12") Sold without copyright; see copyright notice in the Buyer's Guide.

**Estimate: £1,000 - 2,000**



**1743**  
Superman/Clark Kent (Christopher Reeve) Photobooth Photos t  
**Superman III (1983)**

Superman/Clark Kent's (Christopher Reeve) photobooth strip from Richard Lester's superhero sequel Superman III. During the film's opening credits, Kent ran into a photo booth, which captured his transformation into Superman. He tore off the bottom photo and handed the image to a child, preventing his secret identity from being discovered. Printed on glossy paper, the four black-and-white photos show different stages of Kent removing his glasses and civilian clothing to reveal his superhero costume underneath.  
Dimensions: 20 cm x 4.5 cm (8" x 1.75")

**Estimate: £2,000 - 4,000**

**1744**  
Hand-drawn Opening Sequence Storyboard Binder n  
**Superman III (1983)**

A hand-drawn opening sequence storyboard binder from Richard Lester's Superman III. Residents of Metropolis experienced a series of unfortunate accidents, culminating with a man drowning in his car who Superman (Christopher Reeve) rescued. This set of 12 storyboards was part of the film's pre-production process. This navy plastic binder features plastic sleeves containing 12 pages, each with a hand-drawn storyboard illustration rendered in graphite. The pages also feature descriptions and scene numbers as well as date stamps and "PRODUCTION: SUPERMAN III" on the top left corner. They exhibit signs of wear from age and use. Dimensions: 31.25 cm x 23 cm x 1.5 cm (12.25" x 9" x 0.5") Sold without copyright; see notice in the Buyer's Guide.

**Estimate: £2,000 - 4,000**





**1745**  
Set of Three Newspapers m  
**Superman III (1983)**

Three newspapers from Richard Lester's superhero sequel Superman III. These production-made newspapers refer to various plot points throughout the film, most notably the incident when Superman turns bad and starts causing trouble around the world. The lot includes a copy of Daily Planet with the headline "Badman at Work!"; a copy of Le Figaro with the headline "Le scandale de Superman"; and a newspaper in Japanese. All three display minor discolouration. Dimensions (largest): 57.5 cm x 42.5 cm (22.75" x 16.75")

**Estimate: £1,000 - 2,000**

**1746**  
Lois Lane's (Margot Kidder) Blouse and Skirt †  
**Superman IV: The Quest For Peace (1987)**

Lois Lane's (Margot Kidder) blouse and skirt from Sidney J. Furie's superhero sequel Superman IV: The Quest for Peace. Lois wore her blouse in the offices of The Daily Planet but the skirt is not obviously seen in the film. The blouse is made of silk and double-breasted and the skirt has a Bermans & Nathans which reads "Margot Kidder 5665 cost.5. Superman IV".

**Estimate: £800 - 1,600**



Christopher Reeve autograph detail

**1747**  
Christopher Reeve -autographed Photo m  
**Superman IV: The Quest For Peace (1987)**

A Christopher Reeve-autographed photo from the production of Sidney J. Furie's action adventure sequel Superman IV: The Quest for Peace. The Quest for Peace was Reeve's last appearance and performance as the iconic Superman. He has autographed this black-and-white photograph of him in character at the bottom in blue marker pen. Dimensions: 25.5 cm x 20.5 cm (10" x 8") The autographs in this lot have been professionally authenticated by expert Garry King; see notice in the Buyer's Guide.

**Estimate: £500 - 1,000**



**1748**  
DC Comics No. 493 with Adrienne Roy Hand-Coloured "Clark Kent's Vanishing Classmates" Interior Colour Guides m  
**Superman Franchise (1978-1987)**

A comic book with 17 hand-coloured pages from the DC Comics Superman series. Included in this lot is a printed copy of issue 350, published in August 1980, as well as the original colour guides for "Clark Kent's Vanishing Classmates", which is the first story featured in the issue. The hand-coloured pages have been coloured using watercolour paints, and annotated with the shade name of each colour. The colourist credited is Adrienne Roy. The comic comprises 36 pages and includes the 17-page "Clark Kent's Vanishing Classmates" story with several incorporated ad pages throughout. Dimensions: 28 cm x 20 cm (11" x 8") Sold without copyright; see notice in the Buyer's Guide.

**Estimate: £500 - 1,000**



**1749**  
Sweeney Todd's (Johnny Depp) Razor Blade m  
**Sweeney Todd: The Demon Barber Of Fleet Street (2007)**

Sweeney Todd's (Johnny Depp) razor blade from Tim Burton's Sweeney Todd: The Demon Barber of Fleet Street. After 15 years of exile, Todd returned to Fleet Street, where he used his straight razors to cut the throats of his victims. The straight razor has remained cursed by its synonymy with the musical and its status as the signature prop from the film. Designed by prop master David Balfour, this stainless steel blade features a unique bas-relief design of an angel, based on illustrations by William Blake, as stated in the film's making of book by the same title. Dimensions: 19 cm x 4 cm x 1 cm (7.5" x 1.5" x 0.5") Blade was dulled by production.

**Estimate: £3,000 - 6,000**



**1750**  
James Delaney's (Tom Hardy) Coat †  
**Taboo (T.V. Series, 2017)**

James Keziah Delaney's (Tom Hardy) black coat from Steven Knight's historical thriller series Taboo. Delaney wore his coat throughout the series, which, along with a top hat, became a signature feature of his look. This black woollen trench coat features a boucle collar and a number of internal tags, one of which reads "Sands Films", and another "A967".

**Estimate: £2,000 - 4,000**



**1751**  
**Limited Edition The Tales of Beedle the Bard Book & The Tales Of Beedle The Bard (2008)**

A collector's limited edition hardcover of J.K. Rowling's fantasy book The Tales of Beedle the Bard. The Children's High-Level Group produced limited first editions of the book in 2008 to fundraise for The Children's Voice campaign. This edition consists of a 179-page leatherbound hardcover book with marbled endpapers, metallic skull bosses, and faux gemstones on the cover; a maroon velvet pouch embroidered with Rowling's signature; 10 Collector's Edition prints of illustrations by Rowling; and a suede-lined leather bookcase. Dimensions: 31.75 cm x 25 cm x 7.25 cm (12.5" x 9.75" x 2.75")

**Estimate: £800 - 1,600**



**1752**  
**General Harlan Bache's (George C. Scott) Military Dress Uniform & Taps (1981)**

General Harlan Bache's (George C. Scott) military dress uniform from Harold Becker's Taps. General Bache wore his military dress uniform during a baccalaureate service. Created by costume supervisor Eddie Marks, this uniform consists of a black wool tie, black trousers with a set of goldenrod-colour stripes down the sides, a matching jacket with gold-colour metal U.S. seal buttons and goldenrod-colour straps around the cuffs. Included with this lot is a black-and-white movie still of Scott in costume. The photo exhibits minor stains. Dimensions: (movie still) 20.25 cm x 25.5 cm (8" x 10")

**Estimate: £1,500 - 3,000**

62.5 cm (24.5")



**1753**  
**T-800 (Arnold Schwarzenegger) Prosthetic Knee Display & Terminator 2: Judgment Day (1991)**

A T-800 (Arnold Schwarzenegger) prosthetic knee display from James Cameron's sci-fi action sequel Terminator 2: Judgment Day. At the film's climax, parts of the T-800's endoskeleton, including its knee, became exposed during its brutal factory fight against the T-1000 (Robert Patrick). The knee is made of cast polyfoam, expertly painted metallic silver. It features Velcro straps at its rear for strapping the prosthetic to the actor's leg. The knee is accompanied by a display with a wooden base and metal rod to secure it for presentation. Dimensions (on display): 22 cm x 22 cm x 62.5 cm (8.75" x 8.75" x 24.5")

**Estimate: £3,000 - 6,000**



**1754**  
**Sideshow Collectibles Plasma Rifle Replica and T-800 Life-Size Bust Replica & Terminator 2: Judgment Day (1991)**

A replica plasma rifle and Terminator skull from James Cameron's Terminator 2: Judgment Day. Plasma rifles were used by Terminators during the film's flashforward scenes. Created by Sideshow Collectibles, this 1:1 scale replica rifle is made of resin painted to look metallic. It comes with its own stand, on which is a plaque reading "Terminator 2 Judgment Day T2 1:1 Scale Endo Rifle Replica". Also included is a 1:1 scale replica T-800 skull, made by the Hollywood Collectibles Group. This fully-licensed replica is made of metal and resin and features a clean chrome finish, acrylic teeth and light-up LED eyes. It plays music and sounds when a button on the back of the skull is pressed. Both items come in their original boxes. The rifle exhibits minor dirtying, and the battery port on the skull is damaged, rendering the electronics nonfunctional, though it may be repairable. Dimensions: 96 cm x 46 cm x 33 cm (37.75" x 18.15" x 13") Contains electronics; see electronics notice in the Buyer's Guide.

**Estimate: £1,000 - 2,000**



**1755**  
**SFX T-800 (Arnold Schwarzenegger) Arm Piece & Terminator 3: Rise Of The Machines (2003)**

An SFX T-800 (Arnold Schwarzenegger) arm piece from Jonathan Mostow's sci-fi action sequel Terminator 3: Rise of the Machines. This silicone and metal arm appliance was designed for the sequence where the T-800 is severely damaged, and thus, the metal endoskeleton beneath his skin is revealed through its wounds. The arm piece comes framed in a glazed display on a laser-cut mount board with a movie still and the film's title. Dimensions: 68.5 cm x 45.75 cm x 10.5 cm (27" x 18" x 4")

**Estimate: £1,000 - 2,000**



**1756**  
T-800's (Arnold Schwarzenegger)  
Sunglasses ◊  
**Terminator 3:  
Rise Of The Machines (2003)**

T-800's (Arnold Schwarzenegger) sunglasses from Jonathan Mostow's Terminator 3: Rise of the Machines. The Terminator found a pair of sunglasses on the dashboard of a truck he commandeered upon his arrival in the present. While Sama T3s were worn by Schwarzenegger in closeup shots throughout the film, similar sunglasses, such as Arnette Ravens, were used in wider shots. This lot consists of a pair of black Arnette Raven sunglasses with black plastic frames and dark lenses, and a hard-shell glasses case with a hand-written label reading "Sama Shiny." The glasses exhibit some wear from use and age, including scuffing and a sticky residue throughout.

**Estimate: £2,000 - 4,000**



**1757**  
T-800 Endoskeleton Leg ◊  
**Terminator Salvation (2009)**

A T-800 endoskeleton leg from McG's Terminator Salvation. In the near future, the human resistance battled against Skynet's hyperalloy T-800 Terminators. This metal and resin leg features half of a knee joint, a shin and a foot with a centre rod, and individual endoskeleton metatarsal rods and phalanges. The leg was painted with a chrome colour-like finish. Production intentionally distressed the leg. It exhibits some additional scuffing and wearing away of the finish, as well as discolouration to the metal. Dimensions: 61 cm x 25.5 cm x 12.75 cm (24" x 10" x 5")

**Estimate: £1,500 - 3,000**



**1758**  
Thelma's (Geena Davis) Bikini and Shorts ◊  
**Thelma & Louise (1991)**

Thelma's (Geena Davis) bikini and shorts from Ridley Scott's Thelma and Louise. Thelma wore her swimming gear as she lounged by the motel pool while her best friend Louise (Susan Sarandon) made their escape plan after having murdered Harlan (Timothy Carhart) for attempting to rape Thelma. This lot consists of a purple and blue neoprene bikini top and bottoms; and a pair of cream floral print cotton shorts. This lot exhibits minor discolouration and worn neoprene material.

**Estimate: £1,200 - 2,400**

**1759**  
Stephen Hawking (Eddie Redmayne)  
Opening Sequence Costume and Jane Wilde  
(Felicity Jones) Screen-matched Floral Dress,  
Cardigan, Turquoise Dress and Accessories †  
**The Theory Of Everything (2014)**

A Stephen Hawking (Eddie Redmayne) opening sequence costume with a Jane Wilde (Felicity Jones) screen-matched floral dress, cardigan, turquoise dress and accessories from James Marsh's The Theory of Everything. Hawking wore his blue velvet suit and bow tie when he first met Wilde, who wore her turquoise dress. Wilde later emerged from a church, wearing white cotton gloves and holding a straw bag. When she heard about Hawking's ALS diagnosis, she wore a floral dress, which matches the one on screen by the alignment of its pattern. The zip of the turquoise dress has detached.

**Estimate: £800 - 1,600**



**1760**  
Makeup FX Production Crew Jacket ◊  
**The Thing (1982)**

A makeup FX production crew jacket from John Carpenter's The Thing. The production's makeup crew numbered 35 special makeup effects artists who worked 14 months on the film. This burgundy satin letterman-style jacket (Size Medium) features open-slit pockets, a nylon front-zip, beige satin lining, and navy blue elastic cuffs, hem, and neck. It features pewter and silver-colour sparkle embroidery of "Makeup FX" on the front right chest, with a large logo of the movie's title at the back. The interior of the jacket features a The Cloth Tattoo tag. It exhibits orange discolouration around the shoulders, arms, and at the back and sides due to prolonged sun exposure.

**Estimate: £1,500 - 3,000**



Front right chest detail



**1761**  
Set of Five Hand-drawn Palmer's (David Clennon)  
Attack and Mac's (Kurt Russell) Survival  
Production Storyboards †△  
**The Thing (1982)**

Set of five hand-drawn Palmer's (David Clennon) attack and Mac's (Kurt Russell) survival production storyboards from John Carpenter's sci-fi horror The Thing. Three of these storyboard panels, hand-drawn in pencil on paper, depict shots from Palmer attacking his comrades as The Thing. These panels are labelled "17", "20", and "21", while the remaining two storyboards depict key shots from the climax involving Mac's endeavour to survive. Dimensions: (largest panel) 28 cm x 21.5 cm (11" x 8.5") Sold without copyright; see copyright notice in the Buyer's Guide.

**Estimate: £600 - 1,200**



**1762**  
Sir Topham Hatt Model Miniature m  
**Thomas & Friends (T.V. Series, 1984-2021)**

A miniature Sir Topham Hatt from the children's television show Thomas & Friends. Sir Topham Hatt, aka The Fat Controller, was the controller of the North Western Railway on Sodor. He often appeared in his black controller's jacket and top hat, but in some episodes, such as Series 5's "Toby's Discovery", he wore a more relaxed set of clothes while off-duty. The model is made of lead and is hand-painted. The arms and head are removable, and the head, as interchangeable, is from a different model miniature, as it features his black top hat. The model has some minor paint wear. Dimensions: 1.5 cm x 3 cm x 6cm (0.5" x 1.25" x 2.25")

**Estimate: £2,000 - 4,000**



**1763**  
Set of Four Goods Wagons Model Miniatures m  
**Thomas & Friends (T.V. Series, 1984-2021)**

Four miniature goods wagons from the children's television show Thomas & Friends. Trains on Sodor pulled goods wagons such as these to transport cargo across the island. These hand-painted pieces are made of wood and resin, and each has steel wheels. The pieces have been intentionally distressed to appear aged and well-used. They exhibit some additional paint wear and the wheels are slightly rusted. Dimensions: (largest) 15 cm x 9 cm x 7 cm (6" x 3.5" x 2.75")

**Estimate: £2,000 - 4,000**



**1764**  
Building and Set Dressing Model Miniatures m  
**Thomas & Friends (T.V. Series, 1984-2021)**

A building and set dressing pieces from the British children's television series Thomas & Friends. The building is made primarily of wood and fibreboard, with resin brickwork and detailing on the exterior. It has been hand-painted. The building is accompanied by six milk barrels, three fuel barrels, one wooden barrel, five wooden boxes, and three wooden pallets. The pallets are made of wood and the rest of the set dressing pieces are resin. Dimensions (building): 28 cm x 36 cm x 28.5 cm (11" x 14.25" x 11.25")

**Estimate: £800 - 1,600**

**1765**  
Series 9000 Crew Gift m  
**Thomas & Friends**  
**(T.V. Series, 1984-2021)**

A crew gift from the production of the long-running children's television show Thomas & Friends. This sculpted crew gift features Thomas, Sir Topham Hatt and seven of the other main engines. It is made of resin embedded with bronze powder, and sits upon a wooden base. Both the base and the back of the sculpture feature a black, felt lining. A sticker on the base reads "Thomas The Tank Engine And Friends - Series 9000, 2004 - 2005". Dimensions: 37 cm x 9 cm x 19 cm (14.5" x 3.5" x 7.5")

**Estimate: £1,500 - 3,000**



**1766**  
Screen-matched Stegosaurus  
Skeleton Model Miniature m  
**Thomas & Friends - Rheneas and the Dinosaur (2005)**

A screen-matched model miniature stegosaurus skeleton from the children's television show Thomas & Friends. Rheneas wanted to prove himself by transporting a dinosaur skeleton in the series nine episode "Rheneas and the Dinosaur". It matches through markings and the positioning of the teeth. The skeleton is made of resin and hand-painted. It is mounted onto the wooden base which was attached to the train. The skeleton is missing three plates along the spine and has a small section chipped off at the base of the tail. Dimensions: 54 cm x 13.5 cm x 23 cm (21.25" x 9" x 5.25")

**Estimate: £1,500 - 3,000**



**1767**  
Large-scale Green Guardsman Figure tΔ  
**Thomas & Friends (T.V. Series, 1984-2021)**

A large-scale green guardsman figure from the Thomas & Friends spin-off series Jack and the Sodor Construction Company. Although this figure was not obviously seen on screen, other guardsman figures of different colours were throughout the series. This large-scale model was produced for the purpose of close-up shots. It is made of resin and expertly hand painted. It exhibits some scratches and scuffs. Dimensions: 6.5 cm x 11.5 cm x 30 cm (2.5" x 4.5" x 11.75")

**Estimate: £1,000 - 2,000**



**1768**  
Model Miniature Banksman with Alternate Head m  
**Thomas & Friends (T.V. Series, 1984-2021)**

A banksman body and a pair of alternate heads from the British children's television series Thomas & Friends. Banksmen worked at the construction sites on Sodor and supervised the heavy machinery. The resin body and heads have been hand-painted and the body features moving arms. The heads - one wearing a peaked cap, the other a hard hat - have ball socket joints and are held in the neck with black tack. The pieces have some paint wear and scratches, and there is the remnants of black tack in the neck and on the heads.  
Dimensions (complete body): 30 cm x 11 cm x 5 cm (11.75" x 4.25" x 2")

**Estimate: £1,000 - 2,000**

**1769**  
Set of Three Model Miniature Figures m  
**Thomas & Friends (T.V. Series, 1984-2021)**

A set of three miniature figures from the children's television show Thomas & Friends. The lot comprises two smaller-scale figures - one resin and one lead - and a slightly larger-scale resin figure. Two of the figures are handymen, with the larger one accompanied by a broom. The lead figure is a firefighter. All three are hand-painted and the two resin figures have moveable arms and heads.  
Dimensions (largest): 9.5 cm x 4 cm x 1.5 cm (3.75" x 1.5" x 0.5")

**Estimate: £600 - 1,200**

**1770**  
Pair of  
Thomas the Tank Engine Faces m  
**Thomas & Friends**  
**(T.V. Series, 1984-2021)**

A pair of Thomas the Tank Engine faces from the children's television show Thomas & Friends. These hand-painted resin faces were used on Thomas model miniatures. One has "TH" handwritten on the reverse and one appears to have "Thomas 1" handwritten, although it is heavily faded. One of the faces has some minor paint wear and a very small crack across the nose. Dimensions (each): 4.5 cm x 4.5 cm x 1.5 cm (1.75" x 1.75" x 0.5")

**Estimate: £500 - 1,000**



**1771**  
Set of Nine Engine Faces m  
**Thomas & Friends (T.V. Series, 1984-2021)**

A set of nine engine faces from the production of the children's television show Thomas & Friends. This lot includes a Thomas face, a Dennis face, four Hank faces, Iron 'Arry and Iron Bert faces, and one Skarloey face.

All of the faces are unpainted and unfinished. The Thomas face and one of the 'Arry and Bert faces have "Thomas 17" and "Bert & Arry 3", respectively, handwritten on the back. Dimensions (Thomas face): 4.5 cm x 4.5 cm x 1 cm (1.75" x 1.75" x 0.5")

**Estimate: £1,500 - 3,000**

**1773**  
Martin Bower-made  
Thunderbird 4 Model m  
**Thunderbirds**  
**(T.V. Series, 1965-1966)**

A Martin Bower-made Thunderbird 4 model based on those seen in Gerry and Sylvia Anderson's sci-fi TV show Thunderbirds. This model was made by master modelmaker Martin Bower for 1992 editions of Thunderbirds The Comic. Bower's credits include Space: 1999, Blake's 7, Alien and Flash Gordon. The hand-painted replica model is made predominantly of wood, with resin detailing. A miniature Gordon Tracy sits in the cockpit behind a clear acrylic screen, and the searchlight at the front can be moved up and down. Dimensions: 41 cm x 17 cm x 16 cm (16.25" x 6.75" x 6.25")

**Estimate: £3,000 - 6,000**



**1772**  
The Costumi d'Arte Collection: Aramis' (Charlie Sheen) Jacket and Porthos' (Oliver Platt) Tunic o  
**The Three Musketeers (1993)**

Aramis' (Charlie Sheen) jacket and Porthos' (Oliver Platt) tunic from Stephen Herek's action-adventure film The Three Musketeers. Aramis wore his jacket and Porthos his tunic during the film's early scenes. This lot comes from the archives of the Italian costume company Costumi d'Arte. Aramis' jacket is made of leather with a linen lining and metal buttons. "Aramis X50 Charlie Sheen" has been handwritten in black marker pen on the label. Porthos' tunic is also made of leather with a linen lining. It features metal buckles, and "Porthos Oliver Platt" has been handwritten in black marker pen on the label.

**Estimate: £1,500 - 3,000**

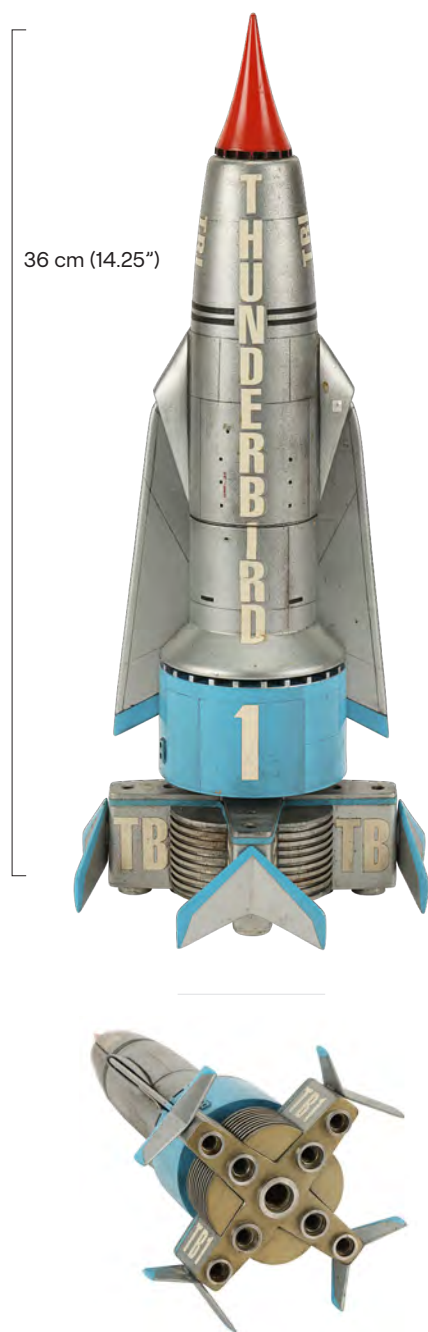

36 cm (14.25")

**1774**  
Martin Bower-made  
Thunderbird 1 Model M  
**Thunderbirds**  
(T.V. Series, 1965-1966)

A Martin Bower-made Thunderbird 1 model based on those seen in Gerry and Sylvia Anderson's sci-fi TV show Thunderbirds. This model was made by master modelmaker Martin Bower for 1992 editions of Thunderbirds The Comic. Bower's credits include Space: 1999, Blake's 7, Alien and Flash Gordon. The hand-painted replica model is made of resin with metal engine rings. Its wings can be extended out into "flight" position and there is a mounting point in the back. Dimensions: 14 cm x 14 cm x 36 cm (5.5" x 5.5" x 14.25")

**Estimate: £2,000 - 4,000**



**1775**  
Sylvia Anderson's  
Photo-matched Lady Penelope  
Creighton-Ward Premiere Dress Ω  
**Thunderbirds Are Go (1966)**

Sylvia Anderson's photo-matched Lady Penelope Creighton-Ward dress from the premiere of David Lane's Thunderbirds Are Go. For the premiere at the London Pavilion, Anderson wore a dress designed to match one worn by her puppet character, Lady Penelope Creighton-Ward. This dress photo-matches to images from the premiere, as well as to a 1995 Phillips Toys & Dolls auction. Designed by Anderson and made by Michel (Mayfair) LTD, this silver lame dress features hand-beaded and sequined turquoise detailing along the chest, back, and arms. The dress exhibits minor discolouration from age and loose threads.

**Estimate: £2,000 - 4,000**



**1776**  
J. Peterman-made  
Rose DeWitt Bukater (Kate Winslet)  
Sinking Coat Replica Ω  
**Titanic (1997)**

A replica of Rose DeWitt Bukater's (Kate Winslet) sinking coat from James Cameron's Titanic made by J. Peterman. Rose wore her dress when the Titanic began sinking. Due to the nature of the scene, the piece would be submerged in a water tank for hours at a time, so several copies of Bukater's sinking coat were produced for use throughout production. This replica (Size 6), was created from production originals and is made of pink wool and polyester with black embroidery along the collar and cuffs, black thread woven buttons over the chest, and a "J Peterman's Movie Legends" tag. It exhibits minor loose threads on the back collar's trim and pilling.

**Estimate: £3,000 - 6,000**



**1777**  
J. Peterman-made  
Rose DeWitt Bukater (Kate Winslet)  
Boarding Costume Replica Ω  
**Titanic (1997)**

A replica of Rose DeWitt Bukater's (Kate Winslet) boarding costume from James Cameron's Titanic made by J. Peterman. Rose wore her dress when she boarded the Titanic. In the spring of 1998, the J. Peterman Company released its own line of Titanic memorabilia that replicated props and costumes from the film. This lot consists of a replica costume consisting of a cream wool jacket with purple velvet trim (Size 8); a black silk charmeuse tie; a cream cotton shirt with lace trim (Size 8); and a cream wool skirt (Size 8). The interior of the jacket, shirt, and skirt feature a "J. Peterman's Movie Legends" tag. This costume exhibits minor discoloration on the shirt.

**Estimate: £3,000 - 6,000**



**1778**  
Life Jacket +Δ  
**Titanic (1997)**

A life vest from James Cameron's Titanic. As the Titanic sank, life vests were worn by crew and passengers alike. This vest is designed to have the exact appearance of those used aboard the real Titanic, except it is filled with foam blocks. It is accompanied by two production stills, one depicting Rose (Kate Winslet) and Jack (Leonardo Di Caprio) as the ship goes down. The second still is of Winslet and Di Caprio on set beside director James Cameron. The lot also includes a certificate of authenticity from 20th Century Fox. The vest exhibits pink stains at the bottom on either side and general dirt marks.

**Estimate: £2,000 - 4,000**



"Heart of the Ocean"  
stone detail

**1779**  
J. Peterman "Heart of the Ocean"  
Necklace Replica M  
**Titanic (1997)**

A replica of the "Heart of the Ocean" necklace from James Cameron's Titanic, created by the J. Peterman Company. J. Peterman sold authorised replicas of the iconic necklace following the film's release. This necklace features 84 faux diamonds linked together in rhodium-plate settings with a heart-shaped blue faux 75-carat diamond solitaire encircled by a single row of faux diamonds. It comes with its original box, and certificate of authenticity. The box exhibits some wear from age, including staining. Dimensions: (box) 26 cm x 22 cm x 4.5 cm (10.25" x 8.75" x 1.75")

**Estimate: £2,000 - 4,000**



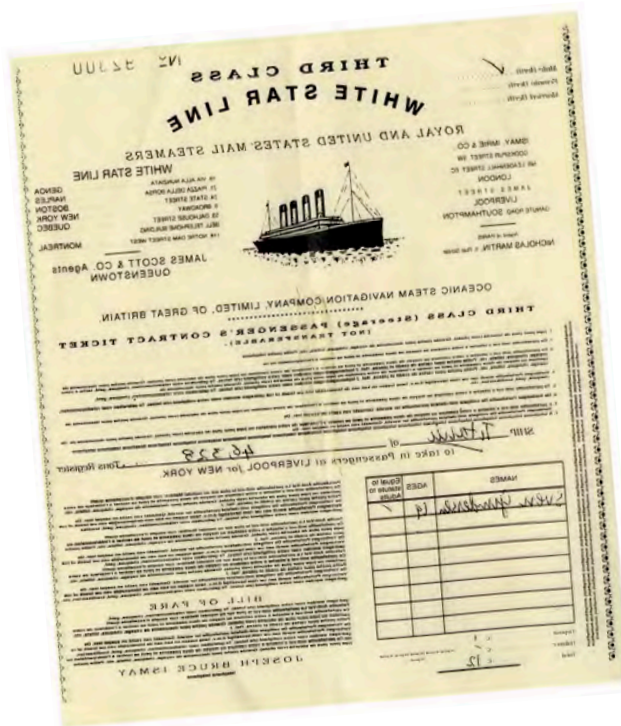

"Heart of the Ocean" stone detail



**1780**  
Jack Dawson's (Leonardo DiCaprio) Titanic Ticket  
**Titanic (1997)**

Jack Dawson's (Leonardo DiCaprio) mirror third-class ticket from James Cameron's romantic disaster film Titanic. Jack won his third-class passenger ticket in a poker game from Sven Gunderson (Dan Pettersson), whose passenger name was filled in at the bottom. The ticket features the printed handwritten annotations for Sven numbered 92300. This ticket exhibits minor wrinkling. Dimensions: 15.25 cm x 18 cm (6" x 7") Additional Provenance: A COA from 20th Century Fox, which notes that the ticket was "Won by Jack in on-shore gambling scene."

**Estimate: £2,000 - 4,000**

**1781**  
J. Peterman Replica "Heart of the Ocean" Necklace  
**Titanic (1997)**

A J. Peterman replica "Heart of the Ocean" necklace from James Cameron's Titanic. J. Peterman sold authorised replicas of the iconic necklace following the film's release. This necklace features 84 faux diamonds linked together in rhodium-plate settings with a heart-shaped blue faux 75-carat diamond solitaire encircled by a single row of faux diamonds. It comes with a blue velvet box, and certificate of authenticity. The box exhibits some wear from age, including staining. Dimensions: (box) 26 cm x 22 cm x 4.5 cm (10.25" x 8.75" x 1.75")

**Estimate: £2,000 - 4,000**



**1782**  
Engineering Officer Jacket + Titanic (1997)

An engineering officer jacket from James Cameron's Academy Award®-winning historical romance Titanic. White Star Line officers wore their jackets as they supervised the engine room crew. This navy blue, double-breasted peacoat has gold-coloured front buttons; each embossed with the White Star logo of a star within a flag. An "Angels" costume label is stitched over an inner pocket, and a handwritten label in the collar indicates the jacket was worn by "Shane McDaid". McDaid was a cast member of the 2013 Titanic musical, indicating that the costume was reused for the stage show. Three poppers are stitched inside under the arms to attach extra costume elements.

**Estimate: £1,500 - 3,000**



**1783**  
Long Sailor Coat + Titanic (1997)

A long sailor coat from James Cameron's 1997 romantic historical drama film Titanic. The sailor's wore their coats throughout the voyage of the eponymous doomed vessel. This long navy blue coat features gold buttons sporting a flag detail. The coat exhibits some damage - there are tears in the lining, lapel, and both cuffs, and the gold thread around the cuffs has been unpicked, likely so that the coat could be reused for another production. There is evidence of repairs on the chest and shoulder.

**Estimate: £1,000 - 2,000**



**1784**  
Life Vest M Titanic (1997)

A life vest from James Cameron's 1997 romantic disaster film Titanic. Passengers made use of their life vests throughout the film's iconic sinking sequences as they struggled to evacuate the vessel. This vest is constructed from an off-white colour nylon canvas with square foam padding stitched into the front and back. Matching wraparound nylon straps are on each side where they are tied in place at the front. The vest exhibits a buildup of grime, frayed threads on the nylon straps, and some discolouration, but otherwise remains in overall very good condition.

**Estimate: £1,000 - 2,000**



**1785**  
Titanic Model Miniature Railing  
**Titanic (1997)**

A Titanic model miniature railing from the production of James Cameron's romantic disaster film Titanic. White rails bordered the decks of the Titanic as she made her doomed maiden voyage. Multiple model miniatures were produced for the disaster film's epic visuals. This particular rail comes from a 1/4th scale "Final Plunge" poop deck model used during the filming of the sinking scenes. The rails are made of metal and painted white, and exhibit significant paint damage, but otherwise remain in good condition. Dimensions: 29 cm x 1 cm x 30 cm (11.5" x 0.5" x 11.75")

**Estimate: £1,000 - 2,000**



Edith Head signature detail

**1786**  
Hand-painted Edith Head Costume Design for Frances Stevens (Grace Kelly) **To Catch A Thief (1955)**

A hand-painted costume design for Frances Stevens (Grace Kelly) from the production of Alfred Hitchcock's *To Catch a Thief*. This design was created by Hollywood legend Edith Head, who won a record eight Academy Awards for costume design throughout her career, and was nominated for her work on the film. Rendered in watercolour, pencil and ink on illustration board, this sketch of Kelly dressed in a green satin gown features handwritten annotations. Head has signed the lower right corner in pencil; the production title and actress' name are written at the top. The design exhibits some minor discolouration due to its age, with marks around the edges and some light smudging on the annotations. Also included is a handwritten letter of authenticity from an acquaintance of Head. Dimensions: 49.75 cm x 37 cm (19.5" x 14.5") Sold without copyright; see copyright notice in the Buyer's Guide. Additional Provenance: Lot 32, Christie's Pop Culture Auction, 29 November 2012

**Estimate: £2,000 - 4,000**



**1787**  
Louis Winthorpe III's (Dan Aykroyd) Santa Costume **Trading Places (1983)**

Louis Winthorpe III's (Dan Aykroyd) Santa costume from John Landis' *Trading Places*. Winthorpe wore his Santa costume while at his lowest point after his wrongful firing and the subsequent unravelling of his life, including when he showed up at his former firm's Christmas party to steal food and plant drugs in Billy Ray Valentine's (Eddie Murphy) desk. This lot consists of a red velveteen jacket with a wool collar, cuffs, and pocket coverings as well as a metal-snap closure hidden beneath decorative buttons; and a matching pair of trousers with a tied waistband. The costume exhibits ripping and staining, primarily on the inside.

**Estimate: £2,500 - 5,000**



**1788**  
Synth Police Droid Costume Display **Total Recall (2012)**

A synth police robot suit display from Len Wiseman's *Total Recall*. Robots were used to police the territories of the United Federation of Britain and the Colony, and thousands were later used by Cohaagen (Bryan Cranston) as a Colony-invading army. The suit comprises a helmet with a black acrylic facemask; a jumpsuit; chest and back guards; a pair of shoulder guards; a waist cover; two arm pieces; a pair of gloves; leg armour; two shin guards; and a pair of shoes. Most of the armour is made of resin and hand-painted, with the waist cover made of brown-painted rubber. The jumpsuit is an elasticated black fabric and has white printed sections to replicate mechanical components, enhanced with CGI in the finished film. Several sections feature printed "Federal Police" badges. The suit comes on a custom-built display stand. It has wear from production use, including some cracking to the rubber sections, paintwear, and white paint markings. Dimensions (displayed): 37.5 cm x 60 cm x 19.5 cm (14.75" x 23.5" x 7.675") Special shipping required; see special shipping notice in the Buyer's Guide.

**Estimate: £3,000 - 6,000**



**1789**  
Cade Yeager's (Mark Wahlberg) Costume **Transformers: Age Of Extinction (2014)**

Cade Yeager's (Mark Wahlberg) costume from Michael Bay's *Transformers: Age of Extinction*. Cade wore his costume as he broke into the Chicago Kinetic Solutions Incorporated base with his daughter's boyfriend, Shane Dyson (Jack Reynor), to stop the company from destroying Autobots to create Transformer drones. This lot consists of a grey cotton long-sleeve shirt; a brown soft leather jacket; blue cotton-blend Joe's jean trousers; and a pair of brown leather Rag and Bone boots (Size 9W) marked "3 Dave" for Wahlberg's stunt double Dave Macomber. This lot exhibits minor stains on the jeans, as well as scuffing to the boots.

**Estimate: £1,500 - 3,000**



**1790**  
Set of Three Kodaliths with Printed Light Cycle Storyboard **Tron (1982)**

Three Kodaliths with a printed storyboard of the light cycle chase from the production of Steven Lisberger's *Tron*. *Tron* was created with a system of animation conceived of specifically for the film using multiple layered, high-contrast mattes. The animation cels used in this process are called Kodaliths. These Kodaliths depicting Flynn and Sark (Warner), one of which is hand-drawn and annotated, are numbered for their scenes with their Kodalith numbers alternately handwritten and printed in their bottom right corners. The storyboard is printed in black-and-white and labelled "Cut back here" in blue ink. Two of the cels are hole-punched by production. Dimensions: (largest) 51 cm x 29.25 cm (20" x 11.5") Sold without copyright; please see notice in the Buyer's Guide.

**Estimate: £800 - 1,600**



**1791**  
Myrmidon Soldier Costume **Troy (2004)**

A Myrmidon warrior's armour from Wolfgang Petersen's adaptation of Homer's great epic *Troy*. Myrmidon soldiers fought under the command of Achilles (Brad Pitt). The costume consists of a helmet, body armour, a pair of greaves and arm bracers made of leather and metal plating. The helmet is made from hard rubber with "I love Pitt" handwritten on the inside in black marker pen. The body armour is made from leather with a woven effect, brass studding and leather overlapping sections on the shoulders, all held in place with leather ties. At the bottom, there are small sections of leather "skirt".

**Estimate: £2,000 - 4,000**



**1792**  
 Pair of Paris' (Orlando Bloom) Bracelets  $\Omega$   
**Troy (2004)**

A pair of Paris' (Orlando Bloom) bracelets from Wolfgang Petersen's Troy. Paris wore his bracelets throughout the film, notably when he battled Menelaus (Brendan Gleeson). This lot consists of two plastic armbands painted to give them a realistic metallic look and are padded on the insides. The bands exhibit minor scuffing and chipped paint.

**Estimate: £1,000 - 2,000**



**1793**  
 Pair of Hector's (Eric Bana) Vambraces  $\Omega$   
**Troy (2004)**

A pair of Hector's (Eric Bana) vambraces from Wolfgang Petersen's Troy. Trojan prince Hector wore vambraces and matching armour as he battled the combined armies of Greece and eventually duelled for the last time with the legendary warrior Achilles (Brad Pitt). This lot consists of two padded dense rubber vambraces ornately detailed with engraved gilded patterns and black elastic ties, painted gold on their exteriors, and finished to appear metallic. The vambraces exhibit grime to their padding.

**Estimate: £1,000 - 2,000**



**1794**  
 Patroclus' (Garrett Hedlund) and Achilles' (Brad Pitt) Necklace  $\Omega$   
**Troy (2004)**

Patroclus' (Garrett Hedlund) and Achilles' (Brad Pitt) necklace from Wolfgang Petersen's Troy. Patroclus wore his seashell necklace throughout the Trojan campaign until his untimely death at the hands of Hector (Eric Bana), after which the necklace was kept by Achilles (Brad Pitt) as a memento of his fallen cousin. This necklace consists of pearlescent seashells attached to loops along a silver-colour metal chain. Metallic green paint has been applied to some of the shells to enhance their natural lustre. The necklace exhibits a crack on the large shell, with the rest exhibiting minor wear from use and age.

**Estimate: £1,000 - 2,000**



**1795**  
 Apollo Statue Head  $M$   
**Troy (2004)**

An Apollo statue head from Wolfgang Petersen's historical epic Troy. During the invasion of the Trojan beach, Achilles (Brad Pitt) chopped the head off of the statue of Apollo. The statue head is made from fibreglass, painted to look like precious gold. As it is a decapitated head part, it was produced for shots after Achilles had perpetrated the disrespectful act. The head exhibits multiple chips on its surface. Dimensions: 47 cm x 32 cm x 44 cm (18.5" x 12.5" x 17.25")

**Estimate: £600 - 1,200**



**1796**  
 LaBoeuf Stunt Costume  $M$   
**True Grit (2010)**

LaBoeuf's stunt Texas Ranger costume from the Coen Brothers' True Grit. LaBoeuf wore his costume throughout the film, including when Ned Pepper dragged him through the dirt from the back of a horse. This costume consists of a suede jacket, waistcoat, a henley shirt, trousers, bandana and a pair of gloves. The shirt has sewn-in labels marked "MD" and "February 2010." The jacket features suede tassels and a rope affixed to the back, and written inside is "Labouef Drag Wide Shots". Written inside the trousers is "Casey drag pants" - referring to Casey O'Neill, Matt Damon's stunt double for the drag scene. A curved repair stitch is present on the back of the trousers, and the costume exhibits some intentional distressing and dirt from production.

**Estimate: £1,500 - 3,000**



**1797**  
 Light-up "Dorothy" Sensor  $\Omega$   
**Twister (1996)**

A light-up "Dorothy" sensor from Jan de Bont's Twister. Storm chasers Bill (Bill Paxton) and Jo Harding (Helen Hunt) used an invention named "Dorothy," which was filled with sensor balls to gather insights on tornadoes. This ball comprises a plastic shell with one transparent half, the other painted silver and chrome to appear metallic. The halves are held together by two metal screws. The interior contains a circuit board, an LED bulb, a battery and a rubber-coated wire, which protrudes from a small hole in the clear half. A switch is located at the seam of the two halves, which operates the LED light, powered by one 6V battery. The ball exhibits chipped paint and discolouration to the metal and interior pieces. Dimensions: 5 cm x 5 cm x 5 cm (2" x 2" x 2") Contains electronics; see electronics notice in the Buyer's Guide.

**Estimate: £2,500 - 5,000**



**1798**  
Bill Harding's (Bill Paxton)  
Distressed Shirt  $\Omega$   
**Twister (1996)**

Bill Harding's (Bill Paxton) distressed shirt from Jan de Bont's *Twister*. Harding's shirt became increasingly filthy and torn-up as he chased deadly tornadoes with his ex-wife, Jo, (Helen Hunt) and visited with Jo's aunt Meg (Lois Smith). This chequered, grey cotton, long-sleeve shirt with a metal snap-button closure on front features an Anto Beverly Hills wardrobe label on the interior labelled "B.P.," dated "1995," and hand-marked "Back-Up" in black marker. It is intentionally distressed throughout by production with grime applied across the left side and on parts of the right, as well as small tears on the front and back. The shirt exhibits additional discolouration on its interior from wear.

**Estimate: £2,000 - 4,000**

**1800**  
The Female's (Scarlett Johansson) Top  $\Omega$   
**Under The Skin (2013)**

The Female's (Scarlett Johansson) lace top from Jonathan Glazer's sci-fi horror *Under the Skin*. The film was acclaimed for Johansson's performance, and ranked 61st on the BBC's 100 Greatest Films of the 21st Century list. The Female wore her lace top underneath her pink top throughout the film, and it was seen most prominently during the scenes in which she seduced and trapped men. The salmon-pink top features lace sections around the midriff, arms and neckline, and a zip runs down the back. The top comes mounted on a custom wood and acrylic display, with a brief description and stills of the top as it appears in the film. Dimensions: 80 cm x 60 cm x 4 cm (31.5" x 24" x 1.5")

**Estimate: £1,000 - 2,000**



**1799**  
S.H.A.D.O. Mobile 3 Large-Scale Model Replica  $\Omega$   
**Ufo (T.V. Series, 1970-1973)**

A replica of a S.H.A.D.O. Mobile 3 from Gerry and Sylvia Anderson's TV series *UFO*. The Supreme Headquarters Alien Defence Organisation operated all-terrain mobiles when resisting UFO invasions. The Andersons employed special and visual effects director Derek Meddings and designer Mike Trim to create the show's vehicles. This replica was built by filmmaker Sean Robinson, with Trim constructing the interior detailing. The main body is made of wood that has been expertly painted to look like metal. Plastic greebles adorn its surface, with the addition of features such as rear doors and vents. It also features stickers, including a "SHADO 3" label. The cockpit windows are made of perspex, and the track is made of banding tape, with painted wooden links and resin wheels. The faux mechanics under the vehicle are also resin. The model has been intentionally distressed to appear battle-used, and its left headlight is missing. Dimensions: 116 cm x 56 cm x 59.5 cm (45.75" x 22" x 23.5") Special shipping required; see special shipping notice in the Buyer's Guide.

**Estimate: £3,000 - 6,000**



**1801**  
Selene's (Kate Beckinsale)  
Hero Light-up Bomb and Remote  $\Omega$   
**Underworld: Awakening (2012)**

Selene's (Kate Beckinsale) hero light-up bomb and remote from Mans Marland and Bjorn Stein's action horror sequel *Underworld: Awakening*. Selene used bombs to blow up lift shafts during her attack on Antigen.

The cylindrical bomb is held together with magnets and can be split in half. Red LED lights illuminate when a button on the top of each half is pressed. The resin remote features a button which illuminates lights when powered with a CR2450 battery. The bomb has some scuffs and scratches and one half of the bomb has a slightly loose covering. Dimensions: 12.5 cm x 9 cm x 9 cm (5" x 3.5" x 3.5")

Contains electronics; see electronics notice in the Buyer's Guide.

**Estimate: £1,500 - 3,000**



**1802**  
GR76's (Ralf Moeller)  
Unisol Load Bearing Harness  $\Omega$   
**Universal Soldier (1992)**

GR76's (Ralf Moeller) Unisol load bearing harness from Roland Emmerich's *Universal Soldier*. UniSol GR76 wore his harness as part of his uniform as he hunted down GR44 with the other soldiers. This lot consists of one harness made of khaki colour canvas and webbed nylon straps with plastic buckles. The interior is handmarked "Rolph Golf[sic]" with illegible text near to the name, as well as an additional "Raf[sic]" handmarked in black ink on the inside of a different strap. This lot exhibits discolouration and pulled threads.

**Estimate: £1,200 - 2,400**



21 cm (8.25")  
Adjusted for readability

**1803**  
Emma Watson Hand-drawn Sketch  $\Omega$   
**Unknown Production**

A sketch hand-drawn by Emma Watson, who played Hermione Granger in the Harry Potter film series. This pencil sketch is of a woman seated by a fire, with a second woman's face suspended above. It is evidently a child's drawing, and likely created during Watson's time starring in the Harry Potter films. In the bottom corner of the picture she has written "By Emma Watson". The paper has become dirtied over time, but otherwise the item remains in very good condition. Dimensions: 30 cm x 21 cm (11.75" x 8.25")

**Estimate: £500 - 1,000**



**1804**  
Jim Malone's Double Sweater Vest  $\Omega$   
**The Untouchables (1987)**

Jim Malone's double sweater vest from Brian De Palma's *The Untouchables*. Malone (Sean Connery) wore his vest in several scenes throughout the film, including when the four Untouchables got their photo taken together at a restaurant. This cable-knit, maroon wool sweater vest features a button-up front and a Capper & Capper label hand-marked "DBL ONLY" in black ink. It exhibits some minor pulls in the knitting.

**Estimate: £1,200 - 2,400**



**1805**  
Diana's (Jane Badler)  
Visitor Jumpsuit  $\Omega$   
**V (1983-1983)**

Diana's (Jane Badler) Visitor jumpsuit from the mini-series *V*. This jumpsuit was also worn in *V: The Final Battle* (1984), and the first episode of the *V* television series (1984-1985). Diana wore her jumpsuit as the Visitors' Chief Science Officer. Made from an orange-coloured fabric, this jumpsuit is paired with a vest that features custom-made embroidered patches on the collar and chest. Three black stripes adorn the shoulder and cuffs. Additionally, the vest has a patch sewn on its front which served as a spot for a squib - a term applied to small explosives which produce bullet-hole effects. Diana is shot in the chest during a staged assassination in "Liberation Day", the first episode of the series. The interior of both vest and jumpsuit are labelled "Diana" in marker pen. The lot shows some minor wear from age and use, including snags on the vest.

**Estimate: £4,000 - 8,000**



**1806**  
Visitor Security Guard Helmet  $\mathfrak{M}$   
**V (T.V. Series, 1984 - 1985)**

A Visitor security guard helmet from the sci-fi TV series *V*. Some Visitor security personnel wore gold-coloured helmets while on duty. This fibreglass helmet has a painted dome and a black plastic visor on the front. There is a black rubber chinstrap and the helmet has a canvas and leather inner lining. The helmet has some wear, including paint wear, chips, and a white powder across both the inside and outside of the visor. Dimensions: 27 cm x 22 cm x 23 cm (10.5" x 8.75" x 9")

**Estimate: £2,000 - 4,000**



**1807**  
V Crowd Mask  $\mathfrak{M}$   
**V For Vendetta (2005)**

A *V* crowd mask from James McTeigue's dystopian sci-fi drama *V for Vendetta*. Underground revolutionary V ((Hugo Weaving)) wore a Guy Fawkes mask throughout the film, as did members of the public during an uprising against the government. Styled in the likeness of Guy Fawkes with a cheerful yet sinister paint finish, the mask is made from vacuum-formed plastic and has foam pads on the forehead and under the eyes for comfort whilst being worn. Dimensions: 16.5 cm x 11.5 cm x 20.25 cm (6.5" x 4.5" x 8")

**Estimate: £3,000 - 6,000**



**1808**  
Set of Production-used Scripts  $\mathfrak{M}$   
**Various Productions**

A set of production-used scripts and other paperwork from three 1970s horror films: Freddie Francis' *Tales from the Crypt* and *The Ghoul*, and Jimmy Sangster's *Lust for a Vampire*. This lot consists of four folders, all of which belonged to Terry Pearce, who served as an assistant director on each of the films. Pearce is best known for his work on *Willow*. Two of the folders feature production paperwork from *Lust for a Vampire*. The script features the working title "To Love a Vampire", and on the reverse of three of the pages Pearce has drawn staging diagrams. Also included is the *Tales from the Crypt* script, credited to Milton Subotsky and 80 pages long. Included with the script are shooting schedules, call sheets, a scene breakdown, and miscellaneous pages handwritten by Pearce. Bound in blue card is the script for *The Ghoul*. Each of the scripts feature Pearce's annotations. Various production paperwork is included with each of the scripts, as well as a picture of actress Veronica Carlson, who played Daphne in *The Ghoul*. Dimensions: 34 cm x 25 cm x 9 cm (13.5" x 10" x 3.5")

**Estimate: £1,000 - 2,000**



**1809**  
Return to Oz Crew Jumper  
and Five Assorted Crew Clothing Items  $\mathfrak{M}$   
**Various Productions**

A size "L" crew jumper from the production of Walter Murch's fantasy-adventure sequel *Return to Oz*, with other crew clothing items from various productions. The other items include an unsized woollen crew jumper from Bill Forsyth's *Local Hero*; a size "XL" crew T-shirt from Ron Howard's *Willow*; a size "L" crew T-shirt from Richard Donner's *The Omen*; and two crew T-shirts from Richard Attenborough's *A Bridge Too Far*, one a size "S" and the other a size "M". The *Local Hero* crew jumper exhibits holes on its rear side, while the crew T-shirts from *The Omen* and *A Bridge Too Far* have shrunk significantly.

**Estimate: £500 - 1,000**



**1810**  
Selina Meyer (Julia Louis-Dreyfus) Book and Badge m  
**Veep (T.V. Series, 2012-2019)**

A Selina Meyer (Julia Louis-Dreyfus) book and badge from HBO's Emmy-award-winning TV series Veep. Meyer took her memoir on a promotional tour during season three. While the cover and opening pages are fictionalised for the show, the remaining text is Glen Chilton's The Curse of the Labrador Duck. The Meyer for President campaign badge is made of plastic and metal. Dimensions: 24.5 cm x 16.5 cm x 3 cm (9.75" x 6.5" x 1.25")

**Estimate: £400 - 800**

**1812**  
Alliance Foot Soldier's Sword, Scabbard, and Shield m  
**Warcraft (2016)**

An Alliance foot soldier's sword, scabbard, and shield from Legendary Pictures' fantasy epic Warcraft. Alliance foot soldiers wielded their signature blue and silver weapons in battles with the Orc Horde. Included are a urethane sword with a silver-colour blade engraved with runes, a hilt inset with a blue urethane gem, and a ridged grip painted blue; a matching shield with leather straps engraved with a Stormwind lion emblem; and a metal-studded brown leather scabbard with Stormwind engravings. The set exhibits intentional distressing to appear battle-used, with scratches, nicks, and fraying leather throughout. Dimensions: (largest) 108 cm x 63.5 cm x 17.25 cm (42.5" x 25" x 1.75")

**Estimate: £1,200 - 2,400**



**1811**  
Ray Ferrier's (Tom Cruise) Leather Jacket m  
**War Of The Worlds (2005)**

Ray Ferrier's (Tom Cruise) leather jacket from Steven Spielberg's sci-fi thriller War of the Worlds. Ray wore his jacket when the "tripod" war machines emerged from the ground following a strange storm, and throughout the tripod attack. It is made of brown leather with white and red detailing, and features production tags inside, as well as a handwritten label which reads "Actual jkt #2 not up to stage 1".

**Estimate: £3,000 - 6,000**



**1813**  
Mrs. Aylwood's (Bette Davis) Jacket +  
**Watcher In The Woods (1980)**

Mrs Aylwood's (Bette Davis) jacket from John Hough and Vincent McEveety's supernatural horror film The Watcher in the Woods. Mrs Aylwood wore her jacket when she rescued Jan (Lynn-Holly Johnson) who had fallen into the pond in the woods. The jacket is unlined, made of a dark grey material, and features a puckered detail across the top of the chest and back. The fabric exhibits some pilling, but otherwise remains in very good overall condition.

**Estimate: £800 - 1,600**



**1815**  
John Wilson's (Clint Eastwood) Shirt and Production Clapperboard m  
**White Hunter Black Heart (1990)**

John Wilson's (Clint Eastwood) safari shirt and a production clapperboard from Clint Eastwood's adventure film White Hunter Black Heart. Wilson wore a military green shirt throughout the film as he and his crew pursued an elephant. The cotton military green shirt features a label with Eastwood's name printed and "16" handwritten over it in black ink. The clapperboard has Eastwood's name and that of the film's director of photography, Jack N. Green, carved into the slate. A set of 18 black-and-white stills of Eastwood in the film accompany the lot, many of which feature him wearing a shirt of this style. Dimensions (clapperboard): 28 cm x 24 cm x 2 cm (11" x 9.5" x 0.75")

**Estimate: £2,500 - 5,000**



122 cm (48")

**1814**  
August Rosenblunth's (Christoph Waltz) Whip,  
Watch and Jewellery m  
**Water For Elephants (2011)**

August Rosenbluth's (Christoph Waltz) whip, watch, and jewellery from Francis Lawrence's Water for Elephants. August wore his watch and jewellery and carried his whip while orchestrating as the Benzini Brothers Circus ringmaster. Created by property master Hope Parrish, this lot consists of one brown leather and metal square-faced watch; two metal and black enamel rings; one gold-colour metal ring; and one black metal and black leather whip with a rubber handle and feathered tip. The rings are tarnished, and the whip and watch exhibit worn leather. Dimensions: (whip) 122 cm x 2.75 cm x 2.75 cm (48" x 1" x 1")

**Estimate: £800 - 1,600**



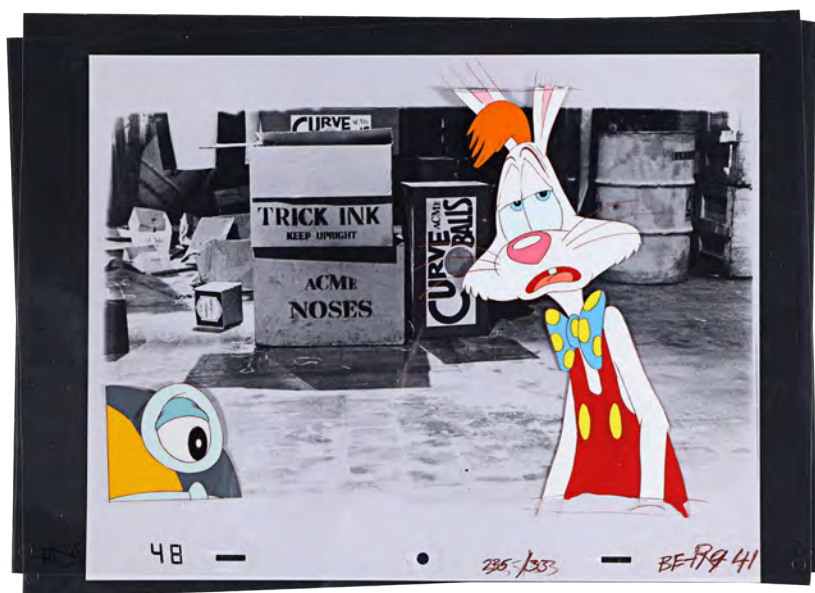

**1816**  
Hand-painted Benny and Roger in the Warehouse Animation Cel m  
**Who Framed Roger Rabbit (1988)**

An animation cel from the production of Robert Zemeckis' fantasy comedy film Who Framed Roger Rabbit. The cel depicts Roger Rabbit and Benny, an animated taxi cab, in the Acme warehouse. The cel is painted onto two sheets of clear acetate, and backed onto a black and white image of the warehouse set, and along the bottom is written "235/33", "R-41" and "BE-19". Dimensions: 30 cm x 42 cm (12" x 16.5") Sold without copyright; see copyright notice in the Buyer's Guide.

**Estimate: £1,000 - 2,000**



**1817**  
Collection of Baby Herman Animation Cels m  
**Who Framed Roger Rabbit (1988)**

Five animation cels from the production of Robert Zemeckis' fantasy comedy film Who Framed Roger Rabbit. The cels depict baby Herman in various poses. Three are outlined in blue, one is fully painted, and one is unpainted. The unpainted cel is annotated with numbers and writing that reads, "Please paint Herman as soon as pos. [sic] No bottle no cigar. TA." With the exception of the painted cel, each cel features two images of Herman. Dimensions: 30 cm x 42 cm (12" x 16.5") Sold without copyright; see copyright notice in the Buyer's Guide.

**Estimate: £1,000 - 2,000**



**1819**  
Hand-painted Jessica Rabbit Animation Cel m  
**Who Framed Roger Rabbit (1988)**

An animation cel from the production of Robert Zemeckis' fantasy comedy film Who Framed Roger Rabbit. The cel depicts Jessica Rabbit stood with her fists clenched at her sides. It is painted onto clear acetate and backed onto blank white paper. Along the bottom the numbers "210/15" and "22" are handwritten, along with the letters "JK". Dimensions: 30 cm x 42 cm (12" x 16.5") Sold without copyright; see copyright notice in the Buyer's Guide.

**Estimate: £800 - 1,600**

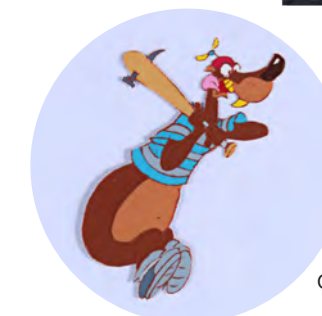

Cel detail

**1820**  
Collection of Hand-painted Toon Patrol Animation Cels m  
**Who Framed Roger Rabbit (1988)**

Five cels from the production of Robert Zemeckis' fantasy comedy film Who Framed Roger Rabbit. The cels depict three members of the Toon Patrol, a group of toon weasels who serve as Judge Doom's (Christopher Lloyd) henchmen. All of the cels are painted onto a clear acetate sheet, and backed onto blank, white pieces of paper. One cel depicts Smarty, the group's leader, while another depicts Greasy running. The other three cels all feature Stupid, jumping and falling over. All five cels feature numbers handwritten across the bottom. Dimensions: 30 cm x 42 cm (12" x 16.5") Sold without copyright; see copyright notice in the Buyer's Guide.

**Estimate: £500 - 1,000**

**1818**  
Hand-painted Roger Rabbit Animation Cel m  
**Who Framed Roger Rabbit (1988)**

An animation cel from the production of Robert Zemeckis' fantasy comedy film Who Framed Roger Rabbit. The cel depicts Roger with his arms and ears down and a look of wonderment on his face. It is painted onto a sheet of clear acetate, with "77-16" and "149" written in black marker along the bottom edge, and backed onto plain paper. Dimensions: 30 cm x 42 cm (12" x 16.5") Sold without copyright; see copyright notice in the Buyer's Guide.

**Estimate: £1,000 - 2,000**



**1821**  
Baby Eborsisk Puppet Heads Display us  
**Willow (1988)**

Baby Eborsisk puppet heads from Ron Howard's Willow. Willow Ufgood (Warwick Davis) turned a troll into an Eborsisk dragon hatchling - named for film critics Roger Ebert and Gene Siskel - by enchanting it with Cherlindrea's (Maria Holvoe) wand. This lot originated directly from visual effects artist Phil Tippett, who created the puppets. It features two foam heads painted pink with bared white teeth mounted onto wooden and metallic puppeteering rods inside an acrylic display case panelled with LED lights. The heads have undergone sympathetic restoration to stabilise the foam around the necks and faces. Still, they exhibit splitting and cracked paint, are missing small pieces, and remain extremely fragile due to age. The lot should be handled with caution. Dimensions: 40.75 cm x 40.75 cm x 84 cm (16" x 16" x 33")

**Estimate: £1,200 - 2,400**



**1822**  
Keith Hamshere Collection:  
Production Photos, Promotional Stills and Polaroid M  
**Willow (1988)**

A collection of production stills, promotional stills and a polaroid from Ron Howard's Willow. This lot comes from the personal collection of renowned stills photographer Keith Hamshere. Included are nine black-and-white photographs and a polaroid. The photographs consist of on-set photography and promotional stills featuring stars Warwick Davis (Willow), Val Kilmer (Madmartigan), Joanne Whalley (Sorsha) and more. Each has a number handwritten in pencil on the reverse. The polaroid shows Val Kilmer in costume on set. Dimensions (each): 40.5 cm x 30.5 cm (16" x 12") Sold without copyright; see copyright notice in the Buyer's Guide.

**Estimate: £1,000 - 2,000**

**1824**  
Sword and Pair of Crew Sweatshirts M  
**Willow (1988)**

A sword and pair of crew sweatshirts from Ron Howard's action adventure Willow. Soldiers of Airk's army wielded swords throughout the film. This fibreglass sword exhibits chips that are a clear sign of production use. The crew letterman jacket is a size "XL". The white crew jumper exhibits some minor stains. Dimensions (sword): 93.5 cm x 15.5 cm x 4.75 cm (36.75" x 6" x 1.75")

**Estimate: £800 - 1,600**



**1823**  
Collection of Production-used Scripts,  
Photographs and Paperwork M  
**Willow (1988)**

A collection of scripts and paperwork from the production of Ron Howard's fantasy film Willow. The lot comprises two scripts, a collection of behind-the-scenes photos, and a collection of paperwork from the film's production, including call sheets, cast lists, audition and costuming paperwork. Of the two scripts, one is bound in blue card, the other bound in brown card. Both are credited to George Lucas and Bob Dolman, designated "Second Draft, Second Revision" and dated "April 1 1987". Each script is 111 pages long and features numerous annotations. The photos are black-and-white and printed on photography paper. Dimensions: 33 cm x 22 cm x 15 cm (13.75" x 10.25" x 6")

**Estimate: £1,000 - 2,000**

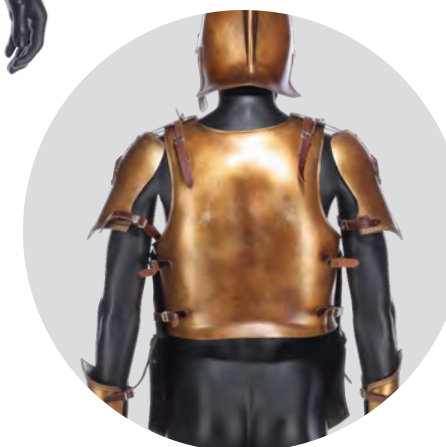

**1825**  
Suit of Temerian Armour M  
**The Witcher (T.V. Series, 2019-Present)**

A suit of Temerian armour from the Netflix fantasy adventure series The Witcher. Soldiers of the Kingdom of Temeria, ruled by King Foltest (Shaun Dooley), wore gold-coloured armour throughout the series. The suit comprises a helmet, a pair of greaves, a chest plate, a pair of vambraces, a pair of cuisses, a pair of pauldrons and two additional armour plates. All its components are made of urethane, finished to resemble gold, and feature leather straps. "ST TMS" is handwritten in black ink on the interior of one of the greaves, "L" is handwritten in black ink on the inside of one of the cuisses, and "TMS 02" and "ST TMS 07" are handwritten on two separate labels stuck to the same cuisses.

**Estimate: £3,000 - 6,000**



**1826**  
Sherlock Holmes' (Michael Caine) Ulster Coat +  
**Without A Clue (1988)**

Sherlock Holmes' (Michael Caine) ulster coat from Thom Eberhardt's crime comedy Without a Clue. Holmes wore his checked coat while he and Dr Watson (Ben Kingsley) investigated the disappearance of Peter Giles (John Warner) in the Lake District. The coat is made from tweed with a nylon inner lining that exhibits some red stains, which are perhaps faux blood. There is also a small hole in the inner lining.

**Estimate: £2,000 - 4,000**





**1827**  
Lawrence Talbot (Benicio Del Toro)  
Werewolf Transformation Costume m  
**The Wolfman (2010)**

Lawrence Talbot's (Benicio Del Toro) werewolf transformation costume from Joe Johnston's period horror film *The Wolfman*. After being turned by his father (Anthony Hopkins), Talbot periodically transformed from man to wolf. The costume consists of a flesh-toned lycra bodysuit, padded with foam to create the more muscular look of the wolf, and covered entirely with faux hair. The costume exhibits hooks around the collar, likely for the purpose of attaching a headpiece. A label reading "Benicio del Toro 1" is stitched into the collar. Some of the hair has thinned in places. Otherwise, it remains in overall very good condition.

**Estimate: £1,000 - 2,000**



**1829**  
Amazonian Bladed Helmet m  
**Wonder Woman (2017)**

An Amazonian helmet from Patty Jenkins' superhero film *Wonder Woman*. Many Amazonian warriors wore their helmets whilst fighting the Germans on Themyscira. The helmet is made of solid resin, painted to look metallic, with foam lining the interior to increase the comfort of the wearer, and a leather chin strap. On the interior of the helmet the word "Stunt" is handwritten. The helmet has been intentionally distressed to create a battle-worn look. Dimensions: 32 cm x 27 cm x 17 cm (12.5" x 11" x 7")

**Estimate: £1,000 - 2,000**



**1828**  
Steve Trevor's (Chris Pine) Stunt Shotgun  
and Chief's (Eugene Brave Rock) Stunt Rifle tΔ  
**Wonder Woman (2017)**

Steve Trevor's (Chris Pine) stunt shotgun and Chief's (Eugene Brave Rock) stunt rifle from Patty Jenkins' *Wonder Woman*. Steve and the Chief used their weapons to fight the Germans alongside *Wonder Woman* (Gal Gadot). Trevor's shotgun is made from hard rubber, with the comb and forearm painted to resemble wood, and the rest of the weapon painted to resemble metal. A metal armature runs through the shotgun to maintain its shape. Chief's rifle is also hard rubber, with the stock and forestock painted to look like wood, and the barrel and midsection painted to look metallic. The end of the shotgun muzzle is slightly chipped. Dimensions: (shotgun) 39.25" x 5.5" x 1.75" (100 cm x 14 cm x 4.5 cm) Restricted ownership; see replica firearm notice in the Buyer's Guide.

**Estimate: £2,000 - 4,000**



**1830**  
Amazonian Queen's Guard Helmet m  
**Wonder Woman (2017)**

An Amazonian Queen's Guard helmet from Patty Jenkins' superhero film *Wonder Woman*. Helmets like these were worn by the Amazonian Queen's Guard on Themyscira, charged with defending Queen Hippolyta (Connie Nielsen). The helmet is made of solid resin, painted to look like metal, with a faux leather fringe. The interior is lined with foam to increase the comfort of the wearer, and the helmet has been intentionally distressed to create a battle-worn look. Dimensions: 31 cm x 18 cm x 33 cm (12" x 7" x 13")

**Estimate: £1,000 - 2,000**



**1832**  
Pair of Zombie Test Make-up Busts m  
**World War Z (2013)**

A pair of zombie test make-up busts from the production of Marc Forster's action horror *World War Z*. Busts were created to explore design concepts for the film's zombies. Both busts are made of fibreglass with silicone prosthetics used to represent the graphic decay caused by the zombie infection. These include raised veins, wide-open cuts and taut skin. Dimensions (tallest bust): 35 cm x 35 cm x 42 cm (13.75" x 13.75" x 16.5")

**Estimate: £2,000 - 4,000**



**1831**  
Set of Lord's House Casino Chips & Plaques m  
**The Wonderful Story Of Henry Sugar (2023)**

A set of Lord's House casino chips from Wes Anderson's comedy short film *The Wonderful Story of Henry Sugar*. Henry (Benedict Cumberbatch) used his ability of seeing through the back of cards at the Lord's House casino to win £30,000 playing Blackjack. Multicoloured betting chips and plaques in quintessential Wes Anderson set design fashion were seen on the tables at the casino. The chips are made of resin, and the plaques are acrylic. Numbers are engraved and printed respectively on the items. Horse heads are subtly engraved into the chips. Dimension: 10.75 cm x 7.5 cm x 0.5 cm (4.25" x 3" x 0.25")

**Estimate: £2,000 - 4,000**



170 cm (67")



**1833**  
Fix-it Felix Jr. Arcade Machine m  
**Wreck-It Ralph (2012)**

A Fix-it Felix Jr. arcade game from the promotion of Rich Moore's animated adventure comedy Wreck-It Ralph. Ralph (John C. Reilly) was the villain of the video game Fix-it Felix Jr, who escaped from the game to try and become a hero. Approximately 50 Fix-it Felix Jr. arcade game cabinets were made by Disney to promote the film, and only two of those were allocated to the UK, of which this is one. In keeping with the film's plot - in which the game is old and forgotten at the back of the arcade - this cabinet has been intentionally distressed and weathered, with cigarette burns, coffee stains and scratches. The game itself has a CRT (cathode-ray tube) display and is powered by a Dell PC. A keyboard and mouse are also housed inside the unit to enable access to PC programming. Dimensions: 86 cm x 60.5 cm x 170 cm (33.75" x 23.75" x 67") Contains electronics; see electronics notice in the Buyer's Guide. Special shipping required; see special shipping notice in the Buyer's Guide.

**Estimate: £3,000 - 6,000**

**1836**  
Erik Lehnsherr's (Michael Fassbender)  
Trick Coin and Close-up Coin m  
**X-Men: First Class (2011)**

Erik Lehnsherr's (Michael Fassbender) trick coin and close up coin from Matthew Vaughn's 2011 superhero film X-Men: First Class. As a child Lehnsherr was brought before Klaus Schmidt (Kevin Bacon) and commanded to move a Reichsmark coin with his magnetic powers. When he failed, his mother Edie (Éva Magyar) was killed by Schmidt. He later used the same coin to kill Schmidt, having kept it with him throughout his life. The coins are both made of metal, and feature engraving typical of a Reichsmark coin. One is larger than the other, for the sake of close-up shots of the coin during the film. Dimensions: 5.5 cm x 5.5 cm x 0.2 cm (2.25" x 2.25" x 0.075")

**Estimate: £500 - 1,000**



**1837**  
Autographed Clapperboard m  
**You Will Meet A Tall Dark Stranger (2010)**

A clapperboard autographed by the cast and crew of Woody Allen's You Will Meet a Tall Dark Stranger. This clapperboard features an acrylic slate and a wooden clapper. It has the film's title above the roll, scene and take numbers, which are handwritten in black ink, and the board is dated "4th August '09". It is autographed by nine cast and crew members, including Antonio Banderas (Greg), Josh Brolin (Roy), Anthony Hopkins (Alfie), and Woody Allen. Dimensions: 28 cm x 23.5 cm x 4.5 cm (11" x 9.25" x 1.75") The autographs in this lot have been professionally authenticated by expert Garry King; see notice in the Buyer's Guide.

**Estimate: £2,000 - 4,000**



**1838**  
Arkansas Dave Rudabaugh's (Christian Slater) Costume m  
**Young Guns II (1990)**

Arkansas Dave Rudabaugh's (Christian Slater) costume from Geoff Murphy's Young Guns II. Rudabaugh wore his costume throughout the film, which depicts the events leading up to Billy the Kid's death following his part in the Lincoln County War. Arkansas Dave was a member of Billy's new gang who endlessly bickered with Billy regarding who was the leader. This lot consists of a wool jacket; cotton shirt; and trousers labelled "CHRISTIAN S." The jacket and shirt feature a bullet hole in the left shoulder and the costume has been intentionally distressed with a large hole in one pant leg and staining. This lot exhibits discolouration.

**Estimate: £2,000 - 4,000**



**1834**  
Alien-Human Hybrid Foetus with Glass Tank m  
**The X-Files - Essence (2001)**

An alien-human hybrid foetus with a glass tank from sci-fi TV series The X-Files. Alien-human hybrids appeared in "Essence", the penultimate episode of Season 8, at the Zeus Genetics lab when Billy (Zachary Aynsley) killed Dr. Lev (David Purdham).

The foetus is made of resin and is hand-painted and intentionally distressed. It features malformed limbs. Also included is a certificate of authenticity from 20th Century Fox, verifying that the prop was screen-used. The glass tank previously contained the liquid it floated in. Dimensions (foetus): 16 cm x 9 cm x 7 cm (6.25" x 3.5" x 2.75")

**Estimate: £1,500 - 3,000**

**1835**  
Cigarette Smoking Man's (William B. Davis)  
Production-made "Trust No One" Lighter m  
**The X-Files (T.V. Series, 1993-2002)**

Cigarette Smoking Man's (William B. Davis) "Trust No One" lighter from the production of Chris Carter's The X-Files. Cigarette Smoking Man lit his favoured Morleys with his signature lighter throughout the series, including in the Season 4 episode "Musings of a Cigarette Smoking Man." This brass, flip-top Zippo lighter engraved "Trust No One" on the front originated from a crew member, as did the Zippo box also included with it, though both were ultimately unseen onscreen. The lighter exhibits some smudging and fibres caught in its hinges from handling, and its current functionality remains untested. Dimensions: 5.25 cm x 7.75 cm x 2 cm (2" x 3" x 0.75") Contains mechanical components; see notice in the Buyer's Guide.

**Estimate: £1,200 - 2,400**

## Terms & Conditions

These terms and conditions of sale (as updated by Propstore from time to time) (“Conditions”) set out the legal relationship between the Bidder/Buyer, Propstore and the Seller. By registering to bid and/or participating in a Propstore Auction, you will be deemed to have read and agree to be bound by these Conditions.

### 1. Definitions

- 1.1. When the following words are used in these Conditions, they mean:

**Additional Premium:** a premium calculated in the manner set out in these Conditions relating to the payment of royalties under the Artists Resales Rights Regulations 2006 (as amended), payable by the Buyer to Propstore on any Lot marked ‘ARR’.

**Auction:** a sale by auction (which may be live or online) hosted by Propstore.

**Bidder:** any person or organisation, properly registered and/or approved by Propstore to participate in the Auction who makes, considers making or attempts to make a bid to buy a Lot at Auction.

**Buyer:** the person or organisation making the highest bid or offer for a Lot accepted by Propstore or its auctioneer (as applicable), including a principal bidding as agent.

**Buyer’s Expenses:** a fee of 5% plus VAT (if applicable) of the Hammer Price charged to the Buyer for a Lot won where an Online Bidding Platform has been used to bid, payable by the Buyer to Propstore.

**Buyer’s Premium:** a commission of 26% (or £30, whichever is higher) plus VAT (if applicable) of the Hammer Price for a Lot, payable by the Buyer to Propstore.

**Cryptocurrency:** the virtual or digital currency accepted by Propstore from time to time as payment for a Lot, using Propstore’s chosen payment processor as notified to the Buyer.

**Entry:** a written statement in the Auction catalogue identifying the Lot and its Lot number, which may also contain a photograph of the Lot taken by Propstore. Please note however any photographs or stills extracted from a TV or film production that appear in the Auction catalogue are provided for illustrative purposes only and do not form part of the Entry. They are not a confirmation that the Lot appeared within the scene portrayed in the relevant photograph or still. Any specific on-camera usage of the Lot known to Propstore will be noted within the Entry.

**Guarantee of Attribution:** Propstore’s limited guarantee relating to the provenance of each Lot, as set out in Condition 10.

**Hammer Price:** the highest bid for a Lot accepted by the auctioneer at the Auction (in the case of a live Auction) or auction platform before the Lot closes (in the case of an online Auction) or the post-Auction sale price of that Lot (as applicable).

**Lot:** each item or group of items consigned by the Seller to Propstore to be made available for sale at an Auction, as detailed in the Entry.

**Online Bidding Platform:** has the meaning given to that term in Condition 6.5.5.6.

**Outstanding Fees:** has the meaning given to that term in Condition 7.14.2.3.

**Propstore:** Prop Store Limited (company number 08622002) of Great House Farm, Chenies, Rickmansworth, Hertfordshire, WD3 6EP. Propstore is also referred to in these Conditions by the words “we”, “us” and “our”.

**Purchase Price:** the Hammer Price plus Buyer’s Premium and, where applicable, plus the Buyer’s Expenses, the Additional Premium, VAT and other sales taxes.

**Reserve Price:** (where applicable) the minimum price at which the Seller has authorised Propstore to sell a Lot.

**Seller:** the person or organisation offering the Lot for sale, including their agents or personal representatives.

**Working Days:** a day other than a Saturday, Sunday or bank or public holiday in England.

**VAT:** value added tax at the prevailing rate in the United Kingdom at the date the Lot sale occurs.

**you** or **your:** means the person or organisation reviewing these Conditions and, where applicable, means the Bidder or Buyer.

### 2. Propstore as Agent

- 2.1. Unless the Entry is marked ‘**A**’ indicating that Propstore sells the Lot as principal, Propstore acts as agent for the Seller. When we act as agent for the Seller, that means we are not personally responsible to you for any breach of contract or other default by the Seller. The contract for the sale of the Lot is made between the Seller (as principal) and the Buyer.

### 3. Catalogue Entry and Condition of Lots

- 3.1. All Lots are sold subject to their condition at the date of the Auction. The nature and age of the Lots means they are often unique and may have wear and tear, damage and other imperfections and may have been totally or partially restored or repaired. By making a bid, the Bidder accepts the actual condition of the Lot and acknowledges that if a bid is successful, the Buyer will buy the Lot from the Seller ‘as is’, with such faults and imperfections.
- 3.2. Propstore’s staff are not professional restorers so the Entry for a Lot, images and statements of condition in Propstore’s brochure or on its website are for illustrative purposes only. Poster Lots in the Auction may have undergone restoration. Propstore staff will make reasonable efforts to identify any restoration and this will be disclosed within the Entry. Propstore cannot guarantee that colours are properly shown. Save for the Guarantee of Attribution (see Condition 10), all Lots are sold ‘as is’.
- 3.3. To avoid doubt, Propstore cannot and does not warrant any restoration or the longevity of any restoration work carried out at any point in a Lot’s lifetime. Bidders are encouraged to inspect Lots and satisfy themselves as to condition before bidding, taking independent professional advice where required.
- 3.4. Condition reports are available for each Lot upon request. However, Propstore is not entering into a contract with you in respect of any condition report provided and accordingly, to fullest extent permitted by applicable law, does not accept any responsibility to you in connection with it. Any condition report provided represents a guide as to the Lot’s general condition in the manner stated in the report and Propstore does not represent or warrant that the condition report is complete or accurate.
- 3.5. Lots are sold only as collectibles and unless stated expressly to the contrary, Propstore makes no representation or warranty that any Lot is fit for any other purpose.
- 3.6. Mannequins, display stands, scale measures and other display equipment are not included with the Lots unless expressly stated in the Lot Entry.

### 4. Estimates

- 4.1. Lot estimates are simply a guide given by Propstore on behalf of the Seller and should not be relied upon as to advice on the Lot’s value or likely bids, Hammer Price or the ultimate Purchase Price, which could be significantly higher. Estimates do not take into account any Buyer’s Premium, Buyer’s Expenses, Additional Premium, VAT, sales taxes or any other costs or fees payable by the Buyer as detailed elsewhere in these Conditions.
- 4.2. Propstore reserves the right to amend any Lot estimate at any time and without notice.

### 5. Before the Auction

- 5.1. Bidder Registration
- 5.1.1. If you wish to make a bid, you will need to register with Propstore before participating at an Auction. Propstore may however, at our discretion, forgo that registration requirement from time to time (this is typically the case if you have a previous purchase history with us).

## Terms & Conditions

- 5.1.2. If your registration is required by us, the registration form made available by us must be completed in full and you will need to provide us with a valid Visa, MasterCard, American Expressor Discover credit card details. Your credit card details will be held on file by Propstore. If you are registering for a live Auction, you must also provide Propstore with the following form of identification, if you are:
- 5.1.2.1. an individual, at least one (1) form of ID (this must include one (1) government-issued photo identification). If this does not state your current address, proof of address will also be required;
- 5.1.2.2. an entity (such as a corporation, limited company or partnership), such information requested by us from time to time. Please contact Propstore on +44 (0)1494 766485 for details on the information required; or
- 5.1.2.3. a person registering as an agent to bid on behalf of a third party, appropriate identification documents as set out above for yourself and for the third party on whose behalf you are authorised to make a bid. You must also provide to Propstore a signed authorisation from the third party confirming your authority to participate at the Auction on their behalf. Please note, any person placing a bid on behalf of another (whether they have disclosed that fact) will be jointly and severally liable with the principal to Propstore and the Seller under these Conditions.
- 5.1.3. Propstore reserves the right at its discretion to request such additional information from time to time to complete our registration and identification processes, and to decline to register or otherwise deregister any person as a Bidder.
- 5.1.4. Without limiting Condition 5.1.3, a person may not register to bid on behalf of another person that has previously been prohibited from registering in any Auction by us.

**5.2. Lot Viewings.** For live Auctions, during the pre-Auction viewing period set out in the Auction catalogue, any Bidder may preview Lots free of charge by prior appointment with Propstore. For online Auctions, all Lots are available for viewing during the Auction period by prior appointment with Propstore

5.3. Bidders outside the United Kingdom

- 5.3.1. If the Bidder is based outside the United Kingdom, the Bidder should ensure in advance of the Auction that the Lot can be exported from the United Kingdom and imported into the country of destination. No sale will be cancelled because the Lot may not be imported into the country of destination.
- 5.3.2. Propstore’s recommended third-party independent freight agent can advise Bidders on relevant export licensing regulations and may submit export licence applications upon request (subject to their acceptance of your request). Neither Propstore nor its recommended freight agents can guarantee that any licences, permits or consents will be granted.

### 6. During the Auction

**6.1. Our rights.** Propstore reserves the right to:

- 6.1.1. refuse admission to any person at a live Auction in its sole discretion, without stating a reason;
- 6.1.2. decide whether an Auction proceeds, whether any Lot is included in the Auction, and the way the Auction is conducted (notwithstanding the numbers given to Lots in the catalogue); and
- 6.1.3. refuse participation at the Auction, to reject any bid and to nominate any bidding increment Propstore considers appropriate. Bids may not be accepted from unregistered bidders and all Bidders must be 18 or over.

**6.2. Reserve Price.** Unless otherwise indicated, all Lots are offered subject to a Reserve Price. The Reserve Price will not exceed the low estimate stated in the Auction catalogue. Propstore may disclose or keep confidential the Reserve Price at its discretion.

**6.3. Auction Electronic Displays.** Live Auctions will be tracked on a video or digital screen, which may display, among other things, a photograph of the Lot offered for sale and the then-current bid. Bidders understand and agree that errors may occur in its operation and, except as expressly stated in these Conditions, Propstore shall have no liability arising out of or related to any errors or omission in respect thereto.

**6.4. Auction Recordings and Photography.** By participating in and/or attending a live Auction, you consent to be filmed and/or photographed and agree and authorise Propstore to use and publish such film and/or photographs, name and likeness for use in:

- 6.4.1. providing online access to the live Auction;
- 6.4.2. recording the results of the live Auction;
- 6.4.3. print, digital, online and all other media for marketing purposes (including without limitation, on Propstore’s website, YouTube and other online platforms); and
- 6.4.4. in any other Propstore publications of whatever nature.

To the fullest extent permitted by applicable law, you release Propstore and holds us harmless from any reasonable expectation of confidentiality or privacy associated with such images and release Propstore and any third parties involved in the making, creation or publication of the videos, images or any marketing or other materials from all and any liability for claims made in respect of such publication. Publication of the videos or images in whatever format confers no right of ownership on you or right to royalties or payment. A designated physical area at the live Auction will be set aside if you do not wish to be filmed or photographed. If you wish to withdraw consent, please email support@propstore.com.

### 6.5. Bidding

- 6.5.1. When making a bid, every Bidder acknowledges that such bid is a binding offer to buy the Lot at that price (plus the Buyer’s Premium, Buyer’s Expenses (if applicable), Additional Premium (if applicable), all applicable taxes and all shipping charges, storage and other costs). A successful Bidder will be deemed to be the Buyer unless it has been explicitly agreed in writing with Propstore before the start of the Auction that the Bidder is acting as agent on behalf of an identified third party acceptable to Propstore (and registered with Propstore), and only then will Propstore regard that third party as the Buyer. In such circumstances, the Bidder acting as agent confirms that they are authorised to bind the third party and that the Buyer has been made aware of and accepts these Conditions. Please note, any person placing a bid on behalf of another (whether they have disclosed that fact) will be jointly and severally liable with the principal to Propstore and the Seller under these Conditions.
- 6.5.2. All bids are by individual Lot unless stated to the contrary. Subject to Condition 6.1.2, Lots will usually be sold in their numbered sequence.
- 6.5.3. All bids must be made in English only.
- 6.5.4. All bids must be made in Pound Sterling (GBP). Propstore (including, in the case of live Auctions, the auctioneer) has the right to exercise reasonable discretion in refusing any bid, advancing the bidding in such a manner as they may decide, withdrawing or dividing any Lot, combining any two or more Lots and, in the case of error or dispute (whether during or after the sale), determining the successful Bidder, continuing the bidding, cancelling the sale or reoffering and reselling the Lot in dispute. If any dispute arises after the sale, then, in the absence of any evidence to the contrary the sale record maintained by Propstore (including, in the case of live Auctions, the auctioneer) will be conclusive.

6.5.5. The following provisions only apply in relation to live Auctions:

6.5.5.1. The auctioneer may accept bids from Bidders present in the sale room, via telephone, online or written bids delivered to Propstore before the Auction commences.

6.5.5.2. Propstore will use reasonable efforts to execute written bids delivered before a live Auction for Bidders unable to attend the Auction in person, by an agent or by telephone or online. All such written bids must be made on Propstore’s ‘Absentee Bids Form’ which can be found in the printed and PDF Auction catalogues and on the Auction listing page.

## Terms & Conditions

- 6.5.5.3. Written bids will be executed at the lowest possible price, considering the Reserve Price.
- 6.5.5.4. If Propstore receives written bids on a particular Lot for identical amounts and at the Auction these are the highest bids on the Lot, it will be sold to the Bidder whose written bid was received and accepted first by Propstore.
- 6.5.5.5. Telephone Bidders must provide to Propstore a list of Lots on which they intend to bid at least 24 hours before the start of the Auction. Telephone bids will only be accepted on Lots with a low-end estimate of at least £500 and telephone calls may be recorded by or on behalf of Propstore.
- 6.5.5.6. Online bidding at Propstore live Auctions is made available via third party platforms (each an **"Online Bidding Platform"**). The Bidder's use of each Online Bidding Platform is subject to the relevant third-party provider's terms of use and is at your own risk. Winning online bids using an Online Bidding Platform in connection with items at a live Auction will be subject to payment of Buyer's Expenses. Propstore have no control over any Online Bidding Platform and accept no responsibility in connection with your use of them and/or their accessibility, security or stability.
- 6.5.5.7. The auctioneer may open the bidding on any Lot below the Reserve Price by placing a (non-identified) bid on behalf of the Seller. The auctioneer may continue to execute (non-identified) bids on behalf of the Seller up to the Reserve Price only, either by placing consecutive bids or by placing bids in response to other Bidders. No bids may be made by the Seller up to, and in excess of, the Reserve Price.
- 6.5.5.8. At its discretion, Propstore reserves the right to apply a bidding cap or suspend bidding privileges to individual Bidders at any point during the Auction period. The cap will be withdrawn once evidence has been submitted to Propstore's satisfaction that all bids are genuine, the Bidder has the means to complete the purchase(s) and any other security checks Propstore may be obliged to carry out have been completed.
- 6.5.5.9. Subject to the auctioneer's reasonable discretion, the Bidder placing the highest bid accepted by the auctioneer (subject to any applicable Reserve Price) will be the Buyer and the striking of his hammer marks the acceptance of the highest bid and the conclusion of a contract for sale between the Seller and the Buyer. However, please note, if a bid is received shortly after the striking of his hammer (as determined by the auctioneer in his reasonable discretion), the auctioneer reserves the right to reopen the Auction for the Lot and shall determine the highest accepted bid.
- 6.5.6. Employees of Propstore may bid in any Auction, however they will have no advantage over other Bidders.
- 6.5.7. In connection with online Auctions, each Lot is open for bidding for a set number of days, the bidding period is stated on the Auction page and individual Lot pages on the website. If any bid is placed within the final minute of the Auction period, the Auction will automatically be extended by one (1) additional minute. Please note that the timer may reflect that the remaining Auction period is "0" but the Auction period has not concluded because it has been extended by a bid made within the last minute. It is the Bidder's responsibility to refresh the page to determine whether the Auction period has been extended. In any event, the Auction period for any Lot shall not be deemed completed until it states "Closed".
- 6.5.8. The procedure for placing bids online during both online and live Auctions is a one-step process; as soon as the "Place Bid" button (or similar) is clicked, a bid is submitted. By bidding online, the Bidder accepts and agrees that bids submitted in this way are final and that the Bidders will not under any circumstances be permitted to amend or retract their bid. If a successful bid is sent to Propstore from the computer, electronic or mobile device used by you to place the bid, you irrevocably agree to pay the full Purchase Price if you are the highest Bidder.
- 6.5.9. The record of sale (i.e., Propstore's records that relate to the sale) will be taken as absolute and final in all disputes. In the event of a discrepancy between any online records or messages provided to you and the record of sale, the record of sale will govern.
- 6.5.10. Save as expressly stated in these Conditions and to the fullest extent permitted by applicable law, Propstore accepts no liability for errors or omissions in respect of bids made online, by telephone or in writing.
- 6.5.11. Propstore (and during live Auctions, the auctioneer) may accept or decline bids at its (or their) entire discretion.

## 7. After the Auction

- 7.1. Invoicing.** Propstore will notify successful Bidders and send (by email unless requested otherwise) a payment invoice setting out the Purchase Price and itemising the Hammer Price and Buyer's Premium (and, where applicable, Buyer's Expenses and Additional Premium) plus any applicable VAT and other sales taxes and costs within 7 calendar days of the end of the Auction.
- 7.2. Risk in the Lot.** To the fullest extent permitted by applicable law, risk and responsibility for the Lot (including frames or glass where relevant) passes to the Buyer on the earlier of :7 calendar days from the date of the Lot sale; on collection of the Lot by the Buyer; or shipment of the Lot to the Buyer (whether arranged by the Buyer or Propstore). We recommend the Buyer arranges insurance cover from the point risk in the Lot passes to them. The term 'risk' has a specific legal meaning that you may not be familiar with. While not intended to limit that legal meaning, to give you an understanding on that term, it is generally considered to mean: the possibility that a Lot may be lost, damaged, destroyed, stolen, or deteriorate in condition or value.
- 7.3. Returns.** Bidders acknowledge and accept that, due to the one-of-a-kind nature of the Lots, Propstore only guarantees the provenance of Lots to the extent set out in the Guarantee of Attribution (see Condition 10) and, to the fullest extent permitted by applicable law, Propstore will not accept returns of any Lots and will not issue refunds, credits or exchanges except as provided for in the Guarantee of Attribution.
- 7.4. Payments**
- 7.4.1. Unless a payment plan (as set out in Condition 7.4.3 below) has been agreed by Propstore, all payments are due from the Buyer within 7 calendar days from the date of Propstore's invoice.
- 7.4.2. Propstore will only accept payment from a Buyer registered with us. Payments from any other source will not be accepted and shall, to the fullest extent permitted by applicable law, be held by Propstore until payment can be made from a source matching the Buyer on record. Only once funds have been received from an accepted source will the original funds be returned. This applies to all forms of payment.
- 7.4.3. At Propstore's discretion, payment plans will be available to the Buyer in 1, 2, or 3 month increments on any invoice over £2,000, unless otherwise specified on the individual Lot. Bidders wishing to utilise the payment plan service, if approved by Propstore, will be responsible for paying a 20% deposit on their Lots within 7 calendar days of invoice date. The balance of the Purchase Price will then be split over 1, 2 or 3 months in accordance with the Buyer's selection and Propstore's agreement. If the 1-month option is selected, the remaining balance on the Lot will be due 30 calendar days after the deposit payment due date. If the 2-month option is selected, half of the remaining balance will be due 30 calendar days after the deposit payment due date and the remaining half 30 calendar days after that, and so on.
- 7.4.4. Propstore offers no grace period on payment plan deadlines or generally. If the Buyer does not make any payment on a payment plan by the due date for payment, the Buyer will have defaulted. In such circumstances and to the fullest extent permitted by applicable law, all funds already paid to Propstore in respect of the relevant Lot will be forfeited by the Buyer and retained by Propstore as liquidated damages, and title of the Lot will not transfer to Buyer. To avoid doubt, Propstore may also sell the Lot to a third party. Propstore and the Seller shall also be entitled to all remedies for non-payment as described below and at law.
- 7.4.5. Payments must be in Pounds Sterling (GBP). The Buyer is responsible for all currency exchange fees incurred by the Buyer and/or Propstore in converting their local currency to GBP. If payment is sent to Propstore otherwise than in GBP, Propstore may at its discretion either reject or accept the payment. If the payment is rejected, Propstore shall return the payment to the Buyer and the Buyer shall pay Propstore on demand all costs incurred by Propstore in remitting the payment back to the Buyer. If the payment is accepted, the currency conversion rate applied shall be the exchange rate applied to the payment by Propstore's bank. If the currency conversion results in Propstore receiving less in GBP than the invoiced amount, the Buyer shall be liable to pay the shortfall to Propstore. Payment may be made by electronic transfer, debit card, credit card (up to a maximum of £25,000 in respect of credit cards), Cryptocurrency (in accordance with Condition 7.4.7 below) or cash (up to a maximum of £5,000 in respect of cash). Please quote the Lot number, invoice number and Bidder registration number when making payment to ensure it can be processed as efficiently as possible.
- 7.4.6. Except as provided in the Guarantee of Attribution and to the fullest extent permitted by applicable law, credit card payments are only acceptable on the express understanding that the Lot is not returnable, refundable nor exchangeable and no charge card credit or refund may be issued in the event of any such return. The Buyer agrees, to the fullest

## Terms & Conditions

- extent permitted by applicable law and except as set out in the Guarantee of Attribution, if payment is made by credit card, Buyer will not undertake any action or effort to stop payment, seek a refund or attempt a charge back of such amounts (or any credit card fee assessed thereon) by the issuer of the credit card.
- 7.4.7. Cryptocurrency payments are accepted via Propstore's payment processor, made available by Propstore from time to time. The Buyer must pay for the entire balance owed including the Purchase Price and any other relevant charges entirely in one form of Cryptocurrency and the Buyer must ensure they have a sufficient balance to pay for all sums owed. We do not accept partial payment or payment plans by Cryptocurrency and a different form of payment in one transaction. To the fullest extent permitted by law and except as set out in the Guarantee of Attribution, Cryptocurrency payment is only acceptable on the express understanding that the Lot is not returnable, refundable nor exchangeable. We also reserve the right to exclude the use of payment by Cryptocurrency on certain Lots, such exclusion to be noted on the listing or as otherwise notified by us from time to time.
- 7.4.8. At our discretion, Propstore may allow Sellers to use proceeds from the sale of their Lots to pay for Auction invoices incurred as a Buyer. Payment of Auction invoices may only be made if the Buyer and Seller are the same person. Sales proceeds may not be transferred between Propstore's offices.
- 7.4.9. Discount codes are not accepted for use against any Auction purchase.

### 7.5. VAT Status

- 7.5.1. Where a Lot's 'VAT Status' is marked **'†'**, this means it is sold under standard VAT rules. For Buyers within (i.e., an individual resident in or businesses registered in) the United Kingdom, 20% VAT will be due on the Hammer Price; and 20% VAT will also be due on the Buyer's Premium and, where applicable, the Buyer's Expenses. When Lots are exported outside the United Kingdom (proof of export required or shipped by Propstore or through Propstore's authorised shipper), no VAT will be due on the Hammer Price; and 20% VAT will be due on the Buyer's Premium and, where applicable, the Buyer's Expenses only, unless items are exported to a business registered outside the United Kingdom, in which case no VAT is due.
- 7.5.2. Where a Lot's 'VAT Status' is marked **'Ω'**, this means the Lot has been temporarily imported from outside the United Kingdom for sale at auction in London. For Buyers within (i.e., an individual resident in or businesses registered in) the United Kingdom, 5% VAT will be due on the Hammer Price; and 20% VAT will also be due on the Buyer's Premium and, where applicable, the Buyer's Expenses. When Lots are exported outside the United Kingdom (proof of export required or shipped by Propstore or through Propstore's authorised shipper), no VAT will be due. However, please note, if such Lots that are not exported outside the United Kingdom within two years from the date the Lot was originally imported into the United Kingdom (Propstore will let the Buyer know when that deadline expires) then 20% VAT will be due on the Hammer Price; and 20% VAT will also be due on the Buyer's Premium and, where applicable, the Buyer's Expenses.
- 7.5.3. Where a Lot's 'VAT Status' is marked **'M'**, this means the Lot is sold under the VAT margin scheme. For Buyers within (i.e., an individual resident in or businesses registered in) Great Britain (i.e. England, Scotland or Wales), no VAT will be due on the Hammer Price; and 20% VAT will be due on the Buyer's Premium and, where applicable, the Buyer's Expenses. For Buyers in Northern Ireland, 20% VAT will be due on the Hammer Price; and 20% VAT will be due on the Buyer's Premium and, where applicable, the Buyer's Expenses. When Lots are exported outside the United Kingdom (proof of export required or shipped by Propstore or through Propstore's authorised shipper), no VAT is due.
- 7.5.4. Where a Lot's 'VAT Status' is marked **'US'**, this means the Lot is currently located in Propstore's Los Angeles facility or elsewhere in the USA and will ship directly to the Buyer from the Los Angeles facility or such other location in the USA. For Buyers within (i.e., an individual resident in or businesses registered in) the United Kingdom, no VAT will be charged by Propstore on the Hammer Price; and 20% VAT will be due on the Buyer's Premium and, where applicable, the Buyer's Expenses. For Buyers outside the United Kingdom, no VAT will be charged by Propstore.
- 7.5.5. Where a Lot's 'VAT Status' is marked **'EU'**, this means the Lot is currently located in a member state of the European Union and will ship directly to the Buyer from such location. For Buyers within (i.e., an individual resident in or businesses registered in) the United Kingdom, no VAT will be charged by Propstore on the Hammer Price; and 20% VAT will be due on the Buyer's Premium and, where applicable, the Buyer's Expenses. For Buyers outside the United Kingdom, no VAT will be charged by Propstore.

- 7.6. Artist Resale Rights.** If a Lot is marked **'ARR'**, an Additional Premium will be payable by the Buyer for royalties relating to the Artists Resale Right Regulations 2006 (as amended). It does not apply on art with a Hammer Price under £1,000. The Additional Premium will be a percentage of the amount of the Hammer Price calculated as follows:

- 7.6.1. Hammer Price from £0 to £50,000: Additional Premium = 4%;
- 7.6.2. Hammer Price from £50,000.01 to £200,000: Additional Premium = 3%;
- 7.6.3. Hammer Price from £200,000.01 to £350,000: Additional Premium = 1%;
- 7.6.4. Hammer Price from £350,000.01 to £500,000: Additional Premium = 0.5%; and
- 7.6.5. Hammer Price exceeding £500,000: Additional Premium = 0.25%.

The Additional Premium is not subject to VAT. Buyers will be charged the Additional Premium in Pounds Sterling (GBP).

- 7.7. Lot Title.** The Buyer will not acquire title to the Lot until all amounts due to the Seller and Propstore from the Buyer (i.e., the Purchase Price and any other costs or expenses incurred by the Buyer in respect of the Lot) have been received by Propstore in cleared funds even in circumstances where Propstore has released the Lot to the Buyer. The term 'title' has a specific legal meaning that you may not be familiar with. While not intended to limit that legal meaning, to give you an understanding on that term, it is generally considered to mean: the legal and equitable right to ownership of the Lot.

- 7.8. Supplied Cards.** By registering with Propstore and to the fullest extent permitted by applicable law, you authorise Propstore to charge: (a) any card supplied by you automatically for a sum of £0.01 to verify the validity of the card; that sum will be returned to you within 30 Working Days of the charge; and (b) the card provided by you at registration (as updated by you from time to time) for all Lots purchased by you at an Auction, if the Purchase Price and/or other costs and expenses payable by you in respect of a Lot are not paid in full within 7 calendar days of the date of our invoice (or where applicable, in accordance with the relevant payment plan pursuant to Condition 7.4.3).

- 7.9. Default Interest.** If the Buyer does not make any payment due to Propstore by the due date for payment, Propstore may to the fullest extent permitted by applicable law, charge interest on the overdue amount at the rate of 5% a year above the base lending rate of Lloyds Bank plc from time to time. This interest shall accrue daily from the due date until the date of actual payment of the overdue amount, whether before or after judgment. The Buyer must pay Propstore such interest together with any overdue amount.

- 7.10. What we can do if a Buyer doesn't pay.** In addition to our rights in Conditions 7.8 and 7.9 and at law, in the event of default by the Buyer, Propstore may, to the fullest extent permitted by applicable law, take one or more of the following actions:

- 7.10.1. hold the Buyer liable for the total amount due relating to the Lot and commence legal proceedings for its recovery together with interest, legal fees and costs to the fullest extent permitted under applicable law;
- 7.10.2. cancel the Lot sale for the Buyer's breach of contract and retain any amounts already paid by the Buyer in respect of the Lot as liquidated damages;
- 7.10.3. resell the Lot publicly or privately on such terms as Propstore shall think fit. If we resell the Lot under this Condition 7.10.3, the Buyer shall be liable for the payment of any deficiency between the total amount originally due to us and the amount received upon resale as well as all reasonable costs, expenses, damages, legal fees and commissions and premiums of whatever kind associated with both sales or otherwise arising from the default. If we pay any amount to the Seller under Condition 7.10.4, the Buyer acknowledges that we shall have the right to enforce all of the Seller's rights, however arising, to pursue the Buyer for such amount;
- 7.10.4. pay the Seller an amount up to the net proceeds payable in respect of the Hammer Price;
- 7.10.5. set off against any amounts which Propstore or any of our affiliates (such as our LA office) may owe to the Buyer in any other transactions, some or all of the outstanding amount remaining unpaid by the Buyer;
- 7.10.6. apply any amount paid to discharge any amount owed in respect of any particular transaction, whether or not the Buyer so directs;

## Terms & Conditions

- 710.7. reject at any future Auction any bids made by or on behalf of the Buyer or to require a deposit from the Buyer before accepting any further bids;
- 710.8. exercise all the rights and remedies of a person holding security over any Lot in Propstore's possession owned by the Buyer, whether by way of pledge, security interest or in any other way by the law of the place where such Lot is located. The Buyer will be deemed to have granted such security to Propstore and Propstore may retain such Lot as collateral security for such Buyer's obligations;
- 710.9. take such other action as Propstore deems necessary or appropriate; and/or
- 710.10. release the name and address of the Buyer to the Seller to enable the Seller to commence legal proceedings to recover the amounts due and legal costs.

**711. Lot Retention.** Propstore shall be entitled to retain Lots sold until all amounts due have been received in full in cleared funds (including, to avoid doubt, all amounts payable under all instalments of a payment plan) or until the Buyer has performed any other outstanding obligations as Propstore shall reasonably require.

### 712. Collection, Shipping and Associated Costs

- 712.1. At a Bidder's request, Propstore can provide shipping estimates for a Lot before the Auction. Bidders requesting this information should email support@propstore.com including the Lot number and shipping address as soon as possible before the start of the Auction. Real-time shipping estimates are also available on many Lots through the Online Bidding Platforms and on our website. Bidders should be aware that oversized Lots may be expensive to ship and enquire for a quote before bidding on those Lots. Propstore is not entering into a contract with you in respect of any shipping estimate provided. Such estimates are provided as a courtesy to Bidders, they are not guaranteed or representative of the amounts payable, and in all cases, the Buyer will be responsible for associated shipping costs. Winning bids are legally binding on the Buyer and must be paid regardless of final shipping costs. To fullest extent permitted by applicable law, Propstore does not accept any responsibility to you in connection with any shipping estimate provided and is not entering into a contract with you in respect of the shipping estimate.
- 712.2. Subject to Condition 711, the Buyer shall collect or have made shipping or collection arrangements for (each at the Buyer's costs and expense) purchased Lots within 7 calendar days from the date of the sale unless otherwise agreed between Propstore and the Buyer. Lots can be collected in person by appointment only.
- 712.3. Each Lot will require a custom packing service and by bidding on a Lot a Bidder agrees to pay all relevant shipping costs. Some Lots will require a special freight service.
- 712.4. Propstore recommends working with its preferred third-party independent freight agent on any questions regarding importing and exporting Lots.
- 712.5. If the Buyer has requested and Propstore agrees to ship the Lot to the Buyer: (a) the Buyer should contact Propstore within 14 calendar days of the date of dispatch if they have not received the Lot; and/or (b) if the item is damaged when delivered to the Buyer, the Buyer should contact Propstore immediately and retain all packaging provided with the shipment.
- 712.6. If Propstore agrees to ship the Lot to the Buyer, risk in the Lot remains with the Buyer during transit in accordance with Condition 72. However, the Buyer may request protection for accidental physical loss or accidental physical damage to the Lot during such shipping to the Buyer. The provision of that protection shall be subject to Propstore's acceptance, the payment of additional charges notified by Propstore to the Buyer and all terms, conditions, limitations, exceptions and exclusions applicable to the protection. Further details on those terms, conditions, limitations, exceptions and exclusions can be requested from Propstore. Where such protection is provided and the Lot suffers accidental physical loss or accidental physical damage during shipping, Propstore does not guarantee that the Buyer will recover the Hammer Price of the relevant Lot or any other costs and expenses incurred by them in connection with the Lot.
- 712.7. It is the Buyer's sole obligation and responsibility to be aware of, to comply with, and to pay for all relevant import duties, taxes, VAT, customs and other fees charged in the Buyer's local jurisdiction. Propstore will ship all packages with the full value of the Lot declared. Buyer understands and agrees that Propstore shall have no obligation or responsibility for any import duties, taxes, VAT, customs, shipping or other charges for the Lots shipped. Failure by the Buyer to pay all necessary amounts may result in the relevant authorities returning the Lot to Propstore and in those circumstances the Buyer will be charged and will pay any return costs incurred by Propstore, storage cost in accordance with these Conditions and Propstore's additional reasonable costs and expenses.
- 712.8. It is the Buyer's responsibility to ensure that any Lot purchased from Propstore enters the shipping location lawfully, that all duties and taxes have been paid and that all required export procedures, regulations, and laws are properly complied with. Buyer understands and agrees that Propstore shall have no obligation or responsibility for complying with any export procedures, regulations or laws applicable to the Lot.
- 712.9. Unless otherwise agreed by Propstore in writing, the fact that the Buyer wishes to apply for an export licence does not affect or postpone the Buyer's obligation to make payment in accordance with Propstore's payment terms nor Propstore's right to charge fees or storage charges on late payment. If the Buyer requests Propstore to apply for an export licence on his or her behalf, Propstore shall be entitled to make a charge and be paid for this service. Propstore will not commence any applications for such licenses until all amounts due to Propstore in respect of the Lot have been received in full and cleared funds (i.e. the Purchase Price and any other costs and expenses incurred by the Buyer in respect of the Lot). Propstore shall not be obliged to rescind or cancel a sale nor to refund any monies paid by the Buyer to Propstore as a result of or related to the Buyer's failure or inability to obtain an export license.
- 712.10. Where Lots are not collected or collected for shipment by the Buyer or authorised for shipment by the Buyer by Propstore within 14 calendar days from the due date for payment of Propstore's invoice for the Lot (or, where a payment plan has been agreed, the due date for payment of Propstore's final invoice under that payment plan for the Lot), whether or not payment has been made, a storage fee equivalent to 3% of the Hammer Price per month shall be charged to the Buyer by Propstore which the Buyer shall pay on demand. If the Buyer has failed to pay the Purchase Price and the cost of shipping and handling, Propstore, at its option may cancel the sale.

### 713. Export and Import

- 713.1. It is the Buyer's sole responsibility to arrange and obtain all necessary export/import licences, permits and any other necessary consents before the Lot is dispatched to the Buyer.
- 713.2. Propstore's third-party independent recommended freight agent will be able to deal with enquiries from Bidders and Buyers on importing and/or exporting of Lots. Propstore accepts no liability for the acts or omissions of any delivery or freight agent appointed by the Buyer.
- 713.3. With regards to Lots exported outside the United Kingdom, if the Buyer's Lots are shipped by Propstore or through Propstore's authorised shipper, except as provided in Conditions 75.1 and 75.2, the Buyer will not be required to pay VAT when settling its invoice. If the Buyer is using any other shipper, or hand carrying its Lots outside the United Kingdom, then VAT will be due on the invoice, which will be refunded (except for any VAT chargeable on the Buyer's Premium and, where applicable, the Buyer's Expenses pursuant to Condition 75.1 on exports outside the United Kingdom to a Buyer that is not a registered business outside the United Kingdom and otherwise pursuant to Condition 75.2 if the Buyer fails to export the Lot within two years of the date the Lot was originally imported into the United Kingdom) once acceptable proof of export is provided by the Buyer's shipper of choice to Propstore.
- 713.4. To prove export of Lots where the 'VAT Status' of a Lot is marked 'Q', 'I' or 'M' and they are not shipped by Propstore or its authorised shipping agents, the Buyer should obtain appropriate official export documentation from its shipper of choice. In all cases Lots must be exported within no more than 3 months of the sale date, and proof of export returned to Propstore.

### 714. Failed Collection or Shipping.

- 714.1. If the Buyer has paid the Purchase Price for a Lot but within 2 years of the end of the Auction in which the Lot was sold:
- 714.1.1. the Lot is not collected or collected for shipment by the Buyer;
- 714.1.2. the Buyer has not provided Propstore with a shipping address;
- 714.1.3. where Propstore organises shipment, the Buyer has not paid shipping and/or delivery costs to Propstore;
- 714.1.4. where Propstore organises shipment, the Buyer has paid the original shipping and/or delivery costs to Propstore but the item is returned to Propstore because the Buyer has failed to pay customs fees to receive the Lot into the country of destination and the Buyer has not paid Propstore any returns costs incurred by Propstore in returning

## Terms & Conditions

the item to Propstore and shipping or delivery costs to re-ship the Lot to the Buyer; or

714.1.5. the Buyer has paid Propstore the relevant shipping or delivery costs but has not authorised Propstore to ship the Lot, then, in each case, Propstore will give the Buyer notice in writing of the need to collect the Lot, provide a shipping address, pay the relevant shipping, delivery and/or return costs and/or authorise the shipment (as applicable). If the Buyer does not take the action required in that notice within 10 calendar days of the date of the notice, Propstore may sell the Lot and the provisions of Condition 714.2 will apply. Propstore do not agree to give the Buyer any further notice of the potential sale. Please note the 2-year period referenced in this Condition may be shorted if the relevant Lot is subject to an export licence. In such circumstances, the relevant period shall be equivalent to the term of the export licence.

714.2. If Propstore exercise its rights to sell the Lot pursuant to Condition 714.1:

714.2.1. Propstore may sell the Lot and, to the extent title to the Lot has transferred to the Buyer, it will immediately transfer to Propstore (or at Propstore's election, back to the Seller);

714.2.2. Propstore may pass ownership of the Lot to the new buyer;

714.2.3. Propstore will use the proceeds of sale to pay: (a) first, Propstore's reasonable costs incurred by it in administering the sale process; and (b) secondly, to pay any debt the Buyer owes to Propstore in respect of the Lot (for example, in respect of unpaid storage fees) (collectively, "**Outstanding Fees**"), and shall then hold the balance for the Buyer. Propstore will not give the Buyer any interest on the balance. To avoid doubt, if Propstore sells the Lot via Auction, the sale proceeds shall be the Hammer Price and shall not include any Buyer's Premium, Buyer's Expenses or Additional Premium paid by the new buyer;

714.2.4. if the proceeds of sale are insufficient to discharge the Outstanding Fees, the Buyer must pay any outstanding balance to Propstore within 14 calendar days of a written demand from Propstore setting out the balance remaining to it; and

714.2.5. Propstore may sell the Lot by any method reasonably available to achieve a selling price reasonably obtainable in the open market, considering the costs of sale. If in Propstore's opinion the Lot cannot be reasonably and economically sold (for whatever reason) or it remains unsold despite Propstore's efforts, the Buyer authorises Propstore to treat the Lot as abandoned by the Buyer and destroy or otherwise dispose of the Lot at the Buyer's cost.

**715. Items marked Q – temporary import.** Please note if a Lot is marked 'Q' and accordingly has been temporarily imported from outside the United Kingdom for sale at auction in the United Kingdom, it will be subject to a temporary import licence for two years from the date of original import to the United Kingdom. If the Buyer has not collected or the Lot has otherwise not been shipped to the Buyer before the expiry of that 2-year period (Propstore will let the Buyer know when that deadline expires), Propstore may ship and repatriate the Lot to its country of origin. The Buyer shall be liable to Propstore for those shipping and repatriation costs and, to avoid doubt, any costs incurred by Propstore in shipping the item to the Buyer from the country of repatriation, each of which shall be payable to Propstore on demand.

**716. 5MLD.** Buyers whose total invoice is equal to or greater than €10,000 (or the GBP equivalent) are required to and agree to undergo enhanced customer due diligence ('EDD') checks required by Propstore in accordance with the EU Fifth Money Laundering Directive ('5MLD'). In accordance with the 5MLD, the Lots won will not be released until the EDD check has been completed and passed. This Condition 716 applies to UK Auctions only.

**717. U.S Wayfair Ruling.** Due to the impact of the U.S. Wayfair ruling, Propstore is obligated to collect sales tax on orders shipped to several states within the United States of America, even when auctioning from London. Additional states become sales tax-eligible regularly due to ongoing updates. You can obtain details on the current list of states Propstore charges sales tax to on request; final taxes will be added to your invoice.

## Sales Tax Quick Reference Guide

Arizona	California	Colorado	Florida	Georgia	Illinois	Indiana	Kansas	Louisiana	Maryland	Massachusetts	Michigan
Minnesota	New Jersey	New York	North Carolina	Ohio	Pennsylvania	Texas	Utah	Vermont	Virginia	Washington	Wisconsin

If you are shipping goods to any of these states, state and local sales tax will be calculated and added to your order based on your address. Propstore charges sales tax in accordance with the individual state requirements; therefore additional states may become taxable for purchases from Propstore at any time. Buyers are encouraged to check with Propstore prior to bidding if they have questions about the sales tax status of potential purchases.

### 8. Data Protection – Use of information

- 8.1. When Propstore obtains any personal information about you, Propstore shall only use it in accordance with the terms of the Propstore privacy policy (available at propstore.com/privacy-policy/ or requested by post or email), which explains what information Propstore collect and hold about you, and how Propstore collect, store, uses and shares such information, and subject to any additional specific consent(s) you may have given at the time your information was disclosed.

### 9. Liability

- 9.1. If Propstore fails to comply with these Conditions, it is responsible for loss or damage a Buyer suffers that is a foreseeable result of Propstore's breach or its negligence. Propstore is not responsible for any loss or damage that is not foreseeable. Loss or damage is foreseeable if an obvious consequence of Propstore's breach or if contemplated by the Buyer and Propstore at the time the hammer falls on the Lot at the Auction.
- 9.2. Subject to Condition 9.3, Propstore's liability shall be limited to the amount of the Purchase Price of the Lot. Save to the extent required by law, in no event shall Propstore be liable for any loss of business, loss of profits, loss of revenue, loss of reputation, or for incidental or consequential damages of any kind.
- 9.3. Propstore does not exclude or limit its liability for:
- 9.3.1. death or personal liability caused by its negligence or the negligence of its employees, agents or subcontractors;
- 9.3.2. fraud or fraudulent misrepresentation; or
- 9.3.3. for any liability that, by applicable law, cannot be limited or excluded.
- 9.4. Propstore will not be liable for any service delays, interruptions or other failures to make a bid caused by losses of internet connection, fault or failure with the Propstore website or bidding process, fault or failure with any third-party platforms (including each Online Bidding Platform), or malfunction of any software, system, computer or mobile device.

### 10. Guarantee of Attribution

10.1. Propstore warrants the attribution of each Lot as stated in the title block (film or artist title and item title) of that Lot in the Entry, subject to any revisions (which may be given in writing or online before or during the Auction at which the Lot is purchased by the Buyer); this is Propstore's **Guarantee of Attribution**. Buyers should be aware that multiple examples of props and costumes are frequently used during production and it is often impossible to determine whether a specific piece has been used on-camera. Please note any photographs or stills extracted from a TV or film production appearing in the Auction catalogue are provided for illustrative purposes only and do not form part of the Entry. They are not a confirmation that the Lot appeared within the scene portrayed in the relevant photograph or still. Any specific on-camera usage known to Propstore will be noted within the Entry, but no warranties are given by Propstore on that Entry. The benefit of the Guarantee of Attribution is personal to the Buyer and is not capable of being assigned. If the Buyer sells or otherwise disposes of its interest in the Lot, the Guarantee of Attribution will cease.

10.2. If a Buyer demonstrates, to Propstore's reasonable satisfaction, that the Guarantee of Attribution is materially incorrect, the sale will be rescinded if the Lot is returned to Propstore in

## Terms & Conditions

the same condition in which it was at the time of sale. The Buyer must notify Propstore as soon as reasonably practicable after they become aware that the Guarantee of Attribution is materially incorrect. To satisfy Propstore that the Guarantee of Attribution is materially incorrect, Propstore reserves the right to require the Buyer to obtain, at the Buyer's expense, the opinion of two experts in the field, mutually acceptable to Propstore and the Buyer.

- 10.3. If Propstore are satisfied the Guarantee of Attribution is materially incorrect and in the event a sale is rescinded in accordance with Condition 10.2, Propstore shall repay to the Buyer the Purchase Price paid by the Buyer and the Buyer will automatically on receipt of such payment transfer the title to the Lot to Propstore or the Seller (as notified by us), free from any encumbrance. Repayment of the Purchase Price shall be the Buyer's sole remedy for an incorrect Guarantee of Attribution, to the exclusion of all other remedies to the fullest extent permissible at law. It is specifically understood that this will be considered the Buyer's sole remedy for any breach of the Guarantee of Attribution.
- 10.4. The Buyer expressly agrees that Propstore shall not be liable in whole or in part, for, and the Buyer shall not be entitled to recover, any special, indirect, incidental or consequential damages including loss of profits or value of investment or opportunity cost.
- 10.5. Bidders acknowledge and accept that Entry revisions may occur on some Lots. Bidders should inquire before the Auction whether any Entry revisions have occurred on a given Lot and/or examine a lot before bidding on it. Propstore will make all reasonable efforts to make Entry revisions readily available during the Auction.
- 10.6. Except as expressly provided in these Conditions, Propstore shall have no liability to the Buyer in respect of a Lot and all and any implied warranties and conditions are excluded to the fullest extent permitted by law.
- 10.7. Please note, if the certificate of authenticity provided by Propstore in respect of the Lot is misplaced, torn or damaged, Propstore will not be able to replace it, nor can Propstore create multiple certificates of authenticity for separate items within a Lot. For an authentic certificate of authenticity, Propstore only provide one document per Lot.
- 10.8. Lots which have been sold as signed or autographed as stated in the Entry, will also be accompanied by an additional certificate of authenticity, guaranteeing that it has been inspected and independently verified by a third party. Please see Condition 14.10 for further information.

### 11. Intellectual Property Rights

- 11.1. The copyright in all images, illustrations and written material produced by or for Propstore relating to a Lot (including the contents of the Auction catalogue), is and shall always remain the property of Propstore (or its licensors) and shall not be used by the Buyer, nor by anyone else, without Propstore's (or the relevant licensor's) written consent. Unless expressly identified by Propstore in writing to the contrary and subject to Condition 11.3, Propstore and the Seller make no representation or warranty that the Buyer of a Lot will acquire any copyright or other reproduction rights in it. To the fullest extent permitted by applicable law, the Buyer agrees to indemnify and hold harmless Propstore, our directors, employees, affiliates, contractors and agents and the Seller from any third-party claims, actions, suits, judgments, losses, damages, costs and expenses asserted against or incurred by Propstore or any of those persons that arise out of or result from any act or omission by the Buyer arising out of or relating to the Buyer's infringement of any copyrights, trademarks or other intellectual property rights in or to the Lots.
- 11.2. In the Entry, Propstore takes steps to identify and provide provenance for Lots offered at Auction. In many cases, the Lots offered were used in or in conjunction with motion pictures or other programmes and information is furnished to fully identify and describe the Lot offered at Auction, including photographs and illustrations. Propstore in no way claims any connection to or relationship with the producers of the motion picture or other programme. In all cases, the use of the titles or other elements of a motion picture or other programme is for informational purposes only.
- 11.3. The Buyer is solely responsible for ascertaining that each Lot is cleared for publication by it including but not limited to satisfying any publicity right that persons appearing in an image may have under any statute or common law. Except as set out in the Auction catalogue, no representation or warranty is given as to any matters that need to be cleared prior to publication by the Buyer or in respect of any intellectual property rights vesting in the Lot. All publication issues should be referred to the Buyer's own professional advisors. If any representations or warranties as to copyright, rights to publish or other intellectual property rights in respect of a Lot are made in the Auction catalogue, they are solely made by the Seller and not Propstore. The Buyer agrees that Propstore will not be liable to Buyer in any respect for alleged breach of any such representation or warranty in such circumstances.

### 12. Events outside our control

- 12.1. Propstore will not be liable or responsible for any failure to perform, or delay in performance of, any of its obligations under these Conditions that is caused by an event outside our control, including, without limitation, strikes, lock-outs or other industrial action by third parties, civil commotion, riot, invasion, terrorist attack or threat of terrorist attack, war (whether declared or not) or threat or preparation for war, fire, explosion, storm, flood, earthquake, subsidence, epidemic or other natural disaster, or failure of public or private telecommunications networks. Propstore's obligations shall be suspended and we shall have a reasonable amount of extra time to perform the obligation impacted by the event outside its control.

### 13. Other important terms

- 13.1. If any part of these Conditions is found by any court to be invalid, illegal or unenforceable, that part shall be removed and the rest of the Conditions shall continue to be valid to the fullest extent permitted by law.
- 13.2. The contract for the sale of the Lot is between the Seller, Buyer and Propstore (as the Seller's agent) and no other person shall have any rights to enforce any of its terms.
- 13.3. If Propstore fails to insist on performance of any Buyer obligations under these Conditions, or if it delays in doing so, that will not mean that Propstore has waived its rights against the Buyer and does not mean the Buyer no longer has to comply with those obligations.
- 13.4. These Conditions and any dispute or claim arising out of or in connection with them or their subject matter or formation (including non-contractual disputes or claims) shall be governed by English law, although if you are resident (in the case of an individual) or incorporated (in the case of a business) outside of England and Wales, you will retain the benefit of any mandatory protection given to you by the laws of that country.
- 13.5. Propstore, the Seller and you agree to submit to the exclusive jurisdiction of the courts of England and Wales, although each party retains the right to bring proceedings against any other for breach of the Conditions in the other party's country of residence (in the case of an individual) or incorporation (in the case of a business). To the fullest extent permitted by applicable law, the prevailing party shall be entitled to an award of all Lawyers' fees and expenses incurred by it/him/her in connection with the dispute. "Lawyers' fees and expenses" includes, without limitation, paralegals', solicitors', consultants', attorneys', expert witness' fees, costs and expenses, and all other expenses incurred by the prevailing party or its lawyers in the course of their representation of the prevailing party in anticipation of and/or during the course of the dispute, whether or not otherwise recoverable as "lawyers' fees" or as "costs" under applicable law; and the same may be sought and awarded in accordance with applicable procedure as pertaining to an award of contractual Lawyers' fees and expenses.

### 14. Special Notices

- 14.1. **Notice on Firearm Deactivation.** Firearms with this disclaimer have been permanently and sympathetically deactivated to United Kingdom legal requirements and no longer retain any functional capacity to fire. A United Kingdom proof house certificate of deactivation is included. For Buyers within the U.S., these Lots may still need to transfer through a Federal Firearms Dealer. It is solely the Buyer's responsibility to check, prior to bidding, the legal status of this weapon within their own country and the importation therein. All costs associated with the transfer will be the Buyer's responsibility.
- 14.2. **Notice on Live Firearms.** These items are legally a firearm and capable of firing ammunition. They must therefore be transferred to a U.S. based Buyer through a Federal Firearms License. You will then have to go through the necessary steps to purchase a firearm, which vary state by state. All costs associated with the transfer will be the Buyer's responsibility. Exporting the piece to the United Kingdom or Europe may be possible if it is deactivated at additional cost; please inquire with Propstore for details.
- 14.3. **Notice on Replica Firearms and UK Restrictions.** Buyers should be aware that ownership of Lots with this disclaimer is restricted for United Kingdom residents to registered re-enactors, galleries, or individuals in film, television or theatre production. Please enquire with Propstore for further details. There may be restrictions applicable to Buyers in other countries as well; it is solely the Buyer's responsibility to check, prior to bidding, the legal status of this item within their own country and the importation therein.
- 14.4. **Notice on Copyright (or similar).** Without limiting Condition 11.1, Lots with this disclaimer are sold without copyright, reproduction rights, licencing agreements or any other type of legal release.
- 14.5. **Notice on Electronics and Mechanics.** Some Lots in the Auction contain electronic and/or mechanical components. While Propstore makes reasonable efforts to describe them

## Terms & Conditions

accurately, no guarantee or warranty is made as to the functionality, lifespan or safety of those components. It is entirely the Buyer's responsibility to satisfy themselves as to their safe use and maintenance.

- 14.6. **Notice on Lots Requiring Special Shipping.** Lots with this disclaimer, due to their size and/or nature will require a specialist shipping service with additional cost. Bidders are strongly advised to contact Propstore for a shipping quote prior to bidding on these Lots.
- 14.7. **Propstore Interest Δ.** From time to time, Propstore may offer a Lot which it owns in whole or in part or in which it has a financial interest. Any such Lot will be identified with the symbol Δ next to its Lot number.
- 14.8. **Notice on Off-Site Storage.** Some Lots in the Auction are stored off-site, outside of Propstore's primary facility. They will ship from their current location to the Buyer's location, at Buyer's expense. These Lots will not be available to preview before the Auction without special arrangements. The Buyer will be responsible for all shipping costs of Lots, regardless of Lot storage location. Please contact Propstore for a shipping quote prior to bidding on off-site storage Lot.
- 14.9. **Notice on Lots Containing Organic Materials.** Certain Lots contain, or may contain, organic materials that may be CITES-listed and therefore subject the Lots to additional restrictions on trade, import or export. It is the Buyer's responsibility to ensure that any Lot purchased from Propstore can be imported to their location lawfully. The Buyer understands that Propstore has no obligation or responsibility in relation to the Buyer's ability to import Lots, and an inability to import Lots will not affect Buyer's obligation to complete the purchase and make payment. Certain permits may be required to accompany the transaction of Lots, for example a CITES permit for Appendix I-listed materials such as rosewood; Propstore will assist in facilitating these permits to the extent reasonably practicable.
- 14.10. **Notice on Autographed Lots.** Lots featuring autographed content will include a certificate of authenticity from specialist Garry King, whose expertise is recognised by collectors and dealers worldwide. Garry has been dealing full time in verifying autographs and documents for over 30 years, having started his collecting obsession when he was just 12 years old. His expertise has been called upon by Trading Standards and the Police and has been accepted as an expert witness by the courts in England and Wales. Garry has appeared as an expert on various national TV programs, including Posh Pawn, Posh Pawn Brokers, The Real Hustle, The One Show, Rip Off Britain, Inside Out and Expert Witness, as well as many regional TV and radio shows. He has also written many articles on autographs and authentication. Garry was voted Dealer of the Year by both AFTAL in 2011 and the UACC in 2000, as well as being awarded the Presidents Quality Award by the UACC in 2006 and currently serves on the board of AFTAL.
- 14.11. **Notice on Lots Containing Blades.** Edged, bladed and blunt weapons are for collection and display purposes only. These Lots are inherently dangerous and are not considered safe or merchantable for any purpose. Propstore, and each of our affiliates, and our and their officers, directors, agents and employees expressly disclaim any liability for damage, injury, harm, cost, expense, or liability arising out of or related to the Buyer's transport, ownership, use or misuse, or possession of these Lots, and shall not be liable to the Buyer or any third party for consequential, indirect, incidental, special, exemplary, punitive or enhanced damages, lost profits or revenues or diminution in value, arising out of, or relating to, and/or in connection with any purchase of these items regardless of (a) whether such damages were foreseeable, (b) whether or not you or they were advised of the possibility of such damages and (c) the legal or equitable theory (contract, tort or otherwise) upon which the claim is based. The Buyer acknowledges that your purchase and use of these Lots is at your sole risk, and that you shall always be solely and fully responsible for the care, maintenance, security and repair of these items.
- 14.12. **Notice on US & EU Storage.** Certain Lots are currently located in Propstore's Los Angeles facility or elsewhere in the USA and will ship directly to the Buyer from the Los Angeles facility or such other location in the USA. Any such Lots will be identified in the catalogue with the symbol 'US' next to its lot number. Buyer will be responsible for all shipping and import charges from the US.

## VAT Quick Reference Guide

VAT Status	Buyer Location / Business or Individual	VAT on Hammer Price	VAT on Buyer's Premium	VAT on Buyer's Expenses
<b>Standard Rules (†)</b>	UK & NI / Individual	20%	20%	20%
	UK & NI / Business	20%	20%	20%
	Rest of World / Individual	0%	20%	20%
	Rest of World / Business	0%	0%	0%
<b>Temporary Import (Ω)</b>	UK & NI	5%	20%	20%
	Rest of World	0%	0%	0%
<b>Margin Scheme (M)</b>	UK	0%	20%	20%
	NI	20%	20%	20%
	Rest of World	0%	0%	0%
<b>Items Outside UK (US and EU)</b>	UK & NI	0%	20%	20%
	Rest of World	0%	0%	0%

Lots 1 - 429

---

**Day 1**  
Thursday, November 14  
Film & Television

Lots 430 - 818

---

**Day 2**  
Friday, November 14  
Music

Lots 819 - 1334

---

**Day 3**  
Saturday, November 16  
Film & Television

Lots 1335 - End

---

**Day 4**  
Sunday, November 17  
Film & Television

\*see separate printed catalog

\*online catalog only

\*online catalog only

**Index**

Film or Show	Page Number(s)	Film or Show	Page Number(s)
<b>#</b>			
2001: A SPACE ODYSSEY (1968)	7	CASABLANCA (1942)	51
300 (2006)	8 - 9	CHARLIE AND THE CHOCOLATE FACTORY (2005)	51 - 52
7TH VOYAGE OF SINBAD, THE (1958)	113	CHITTY CHITTY BANG BANG (1968)	52 - 53
<b>A</b>		CLASH OF THE TITANS (1981)	130 - 136
AD ASTRA (2019)	10	CLEOPATRA (1963)	53 - 60
ADJUSTMENT BUREAU, THE (2011)	9	CLOSE ENCOUNTERS OF THE THIRD KIND (1977)	61
ALIEN (1979)	10 - 11	CULT OF CHUCKY (2017)	62
ALIENS (1986)	12 - 21, 23	<b>D</b>	
ARMY OF DARKNESS (1992)	23	DARK CRYSTAL, THE (1982)	63
ARTHUR (1981)	24	DARK KNIGHT, THE (2008)	45
ASH VS EVIL DEAD (TV. SERIES, 2015-2018)	24 - 25	DISNEYLAND PARK	64 - 65
AUSTIN POWERS IN GOLDMEMBER (2002)	26	DOCTOR STRANGE (2016)	214
AVPR: ALIENS VS. PREDATOR - REQUIEM (2007)	22	DOCTOR STRANGE IN THE MULTIVERSE OF MADNESS (2022)	214
<b>B</b>		DOCTOR WHO - THE DAY OF THE DOCTOR (2013), THE TIME OF THE DOCTOR (2013)	67
BACK TO THE FUTURE (1985)	26 - 27	DOCTOR WHO (TV. SERIES, 2005-PRESENT)	68
BACK TO THE FUTURE PART II (1989)	28 - 33	DOCTOR WHO ORIGINAL SERIES - THE WEB OF FEAR (1968)	66
BACK TO THE FUTURE PART II (1989)/BACK TO THE FUTURE PART III (1990)	30 - 31	DOCTOR WHO ORIGINAL SERIES (TV. SERIES, 1963 - 1989)	66
BACK TO THE FUTURE PART III (1990)	34 - 35	DON POST STUDIOS	108
BATMAN & ROBIN (1997)	42 - 44	DUELLISTS, THE (1977)	69 - 70
BATMAN BEGINS (2005)	44	<b>E</b>	
BATMAN FOREVER (1995)	41	EDGE OF TOMORROW (2014)	71 - 72
BATMAN RETURNS (1992)	36 - 40	ELIZABETH (1998)	72
BEN-HUR (1959)	46	ELYSIUM (2013)	73
BLADE (1998)	47	<b>F</b>	
BLADE RUNNER (1982)	48	FEMALE TROUBLE (1974)	73
BOOGIE NIGHTS (1997)	49	FIFTH ELEMENT, THE (1997)	74 - 75
BREAKFAST AT TIFFANY'S (1961)	49 - 50	FINDING NEVERLAND (2004)	76
BRIDGET JONES'S DIARY (2001)	50	FORREST GUMP (1994)	77
<b>C</b>		FRAGGLE ROCK (TV. SERIES, 1983-1987)	78 - 79
CAPTAIN AMERICA: THE FIRST AVENGER (2011)	213	FREDDY VS. JASON (2003)	80
		FRIENDS - THE ONE WITH THE PRINCESS LEIA FANTASY (1996)	80

Lots 1 - 429

---

**Day 1**  
Thursday, November 14  
Film & Television

Lots 430 - 818

---

**Day 2**  
Friday, November 14  
Music

Lots 819 - 1334

---

**Day 3**  
Saturday, November 16  
Film & Television

Lots 1335 - End

---

**Day 4**  
Sunday, November 17  
Film & Television

\*see separate printed catalog

\*online catalog only

\*online catalog only

**Index**

Film or Show	Page Number(s)	Film or Show	Page Number(s)
FRIENDS - THE ONE WITH THE PRINCESS LEIA FANTASY (1996), THE ONE WITH PHOEBE'S EX-PARTNER (1997)	81	HELLRAISER (1987)	159
FROM DUSK TILL DAWN (1996)	81	HIGHLANDER (1986)	160 - 162
FULL METAL JACKET (1987)	82	HIGHLANDER (TV. SERIES, 1992-1998)	163
<b>G</b>		HOOK (1991)	162
GAME OF THRONES (TV. SERIES, 2011-2019)	82 - 83	HOUSE OF THE DRAGON (TV. SERIES, 2022-PRESENT)	164
GHOSTBUSTERS II (1989)	83 - 85	<b>I</b>	
GHOSTBUSTERS: FROZEN EMPIRE (2024)	85	I AM LEGEND (2007)	165
GLADIATOR (2000)	86 - 91	INDIANA JONES AND THE DIAL OF DESTINY (2023)	170
GODFATHER PART III, THE (1990)	93	INDIANA JONES AND THE RAIDERS OF THE LOST ARK (1981)	166 - 168
GOLDEN VOYAGE OF SINBAD, THE (1973)	118 - 124	INDIANA JONES AND THE TEMPLE OF DOOM (1984)	168 - 169
GOOD, THE BAD AND THE UGLY, THE (1966)	94 - 98	INDIANA JONES: ORIGINAL TRILOGY (1981-1989)	171
GRAN TORINO (2008)	99	INGLOURIOUS BASTERDS (2009)	171
GRAND DUEL, THE (1972)	99	<b>J</b>	
GREMLINS (1984)	100 - 102	JAMES BOND COLLECTIBLES	172
GREMLINS 2: THE NEW BATCH (1990)	103 - 107	JAMES BOND: CASINO ROYALE (2006)	192
GUARDIANS OF THE GALAXY (2014)	216	JAMES BOND: DIAMONDS ARE FOREVER (1971)	182 - 184
<b>H</b>		JAMES BOND: DIE ANOTHER DAY (2002)	190 - 191
HALLOWEEN: RESURRECTION (2002)	109	JAMES BOND: DR. NO (1962)	173
HARRY POTTER AND THE CHAMBER OF SECRETS (2002)	150	JAMES BOND: FOR YOUR EYES ONLY (1981)	185
HARRY POTTER AND THE DEATHLY HALLOWS: PART 1 (2010)	156	JAMES BOND: FROM RUSSIA WITH LOVE (1963)	173 - 174
HARRY POTTER AND THE GOBLET OF FIRE (2005)	153 - 154	JAMES BOND: GOLDENEYE (1995)	186 - 187
HARRY POTTER AND THE ORDER OF THE PHOENIX (2007)	154 - 156	JAMES BOND: GOLDFINGER (1964)	174 - 175
HARRY POTTER AND THE PHILOSOPHER'S STONE (2001)	148 - 150	JAMES BOND: MOONRAKER (1979)	184 - 185
HARRY POTTER AND THE PHILOSOPHER'S STONE (2001)/HARRY POTTER AND THE CHAMBER OF SECRETS (2002)	145	JAMES BOND: NO TIME TO DIE (2021)	196 - 197
HARRY POTTER AND THE PRISONER OF AZKABAN (1999)	153	JAMES BOND: ON HER MAJESTY'S SECRET SERVICE (1969)	181
HARRY POTTER AND THE PRISONER OF AZKABAN (2004)	151 - 152	JAMES BOND: SKYFALL (2012)	193 - 194
HARRY POTTER SERIES (2001 - 2011)	146 - 147, 150	JAMES BOND: SPECTRE (2015)	194 - 195
HATEFUL EIGHT, THE (2015)	143 - 144	JAMES BOND: THE SPY WHO LOVED ME (1977)	184
HELLBOY (2004)	157 - 158	JAMES BOND: THE WORLD IS NOT ENOUGH (1999)	187 - 190
HELLBOY II: THE GOLDEN ARMY (2008)	158	JAMES BOND: THUNDERBALL (1965)	175
		JAMES BOND: YOU ONLY LIVE TWICE (1967)	176 - 180

Lots 1 - 429

---

**Day 1**  
Thursday, November 14  
Film & Television

Lots 430 - 818

---

**Day 2**  
Friday, November 14  
Music

Lots 819 - 1334

---

**Day 3**  
Saturday, November 16  
Film & Television

Lots 1335 - End

---

**Day 4**  
Sunday, November 17  
Film & Television

\*see separate printed catalog

\*online catalog only

\*online catalog only

**Index**

Film or Show	Page Number(s)
JASON AND THE ARGONAUTS (1963) .....	110 - 113, 139 - 142
JEEPERS CREEPERS (2001) .....	197
JUDGE DREDD (1995) .....	198 - 199
JUMANJI (1995) .....	200 - 201
<b>L</b>	
LA DOLCE VITA (1960) .....	202
LADYHAWKE (1985) .....	202 - 203
LARA CROFT: TOMB RAIDER - THE CRADLE OF LIFE (2003) .....	314
LARA CROFT: TOMB RAIDER (2001) .....	314
LAST SAMURAI, THE (2003) .....	203
LAWRENCE OF ARABIA (1962) .....	204
LORD OF THE RINGS TRILOGY, THE (2001-2003) .....	205
LOST WORLD, THE (1925)/KING KONG, THE (1933) .....	206 - 207
<b>M</b>	
MAD MAX: FURY ROAD (2015) .....	208 - 209
MARILYN MONROE .....	210 - 211
MARS ATTACKS! (1996) .....	212
MARTIAN, THE (2015) .....	213
MATRIX RELOADED, THE (2003)/THE MATRIX REVOLUTIONS, THE (2003) .....	217
MATRIX RESURRECTIONS, THE (2021) .....	216
MIGHTY MORPHIN POWER RANGERS: THE MOVIE (1995) .....	220
MONTY PYTHON'S LIFE OF BRIAN (1979) .....	218
MONTY PYTHON'S THE MEANING OF LIFE (1983) .....	218 - 219
MUMMY RETURNS, THE (2001) .....	221
MUMMY, THE (1999) .....	220 - 221
<b>N</b>	
NAPOLEON (2023) .....	222
NIGHTBREED (1990) .....	223 - 224
<b>O</b>	
ONCE UPON A TIME IN THE WEST (1968) .....	225 - 228
<b>P</b>	
PADDINGTON (2014) .....	229

Lots 1 - 429

---

**Day 1**  
Thursday, November 14  
Film & Television

Lots 430 - 818

---

**Day 2**  
Friday, November 14  
Music

Lots 819 - 1334

---

**Day 3**  
Saturday, November 16  
Film & Television

Lots 1335 - End

---

**Day 4**  
Sunday, November 17  
Film & Television

\*see separate printed catalog

\*online catalog only

\*online catalog only

**Index**

Film or Show	Page Number(s)
SHERLOCK HOLMES (2009) .....	254
SINBAD AND THE EYE OF THE TIGER (1977) .....	126 - 130
SMALL SOLDIERS (1998) .....	254
SNAKE EYES (1998) .....	255
SPEED (1994) .....	255
SPIDER-MAN (2002) .....	256 - 257
STAR TREK BEYOND (2016) .....	261
STAR TREK INTO DARKNESS (2013) .....	260 - 261
STAR TREK: DEEP SPACE NINE (TV. SERIES, 1993-1999) .....	262
STAR TREK: GENERATIONS (1994) .....	259 - 260
STAR TREK: THE MOTION PICTURE (1979) .....	258 - 259
STAR TREK: THE NEXT GENERATION (TV. SERIES, 1987-1994) .....	261
STAR TREK: THE NEXT GENERATION (TV. SERIES, 1991) .....	262
STAR TREK: VOYAGER (TV. SERIES, 1995-2001) .....	262 - 263
STAR WARS: A NEW HOPE (1977) .....	264 - 280, 285, 288
STAR WARS: ATTACK OF THE CLONES (2002) .....	294 - 295
STAR WARS: ORIGINAL TRILOGY (1977-1983) .....	286 - 287
STAR WARS: RETURN OF THE JEDI (1983) .....	284
STAR WARS: REVENGE OF THE SITH (2005) .....	296 - 297
STAR WARS: THE COMPLETE SAGA .....	298
STAR WARS: THE EMPIRE STRIKES BACK (1980) .....	282 - 283, 288 - 289
STAR WARS: THE EMPIRE STRIKES BACK (1980)/STAR WARS: RETURN OF THE JEDI (1983) .....	281
STAR WARS: THE PHANTOM MENACE (1999) .....	290 - 293
STARDUST (2007) .....	299
STARGATE (1994) .....	300
STARGATE SG-1 (1997-2009) .....	301
<b>T</b>	
TENACIOUS D IN THE PICK OF DESTINY (2006) .....	301
TERMINATOR 2: JUDGMENT DAY (1991) .....	302 - 304
TERMINATOR SALVATION (2009) .....	305
TEXAS CHAINSAW 3D (2013) .....	305
THING, THE (1982) .....	306 - 307

Film or Show	Page Number(s)
THOMAS & FRIENDS (TV. SERIES, 1984-2021) .....	308 - 309
THOR (2011) .....	215
THUNDERBIRDS - THE MARTIAN INVASION (1966) .....	310
THUNDERBIRDS (1965-1966)/CAPTAIN SCARLET AND THE MYSTERONS (1967-1968) .....	311
TITANIC (1997) .....	312 - 314
TOMB RAIDER (2018) .....	315
TOP GUN: MAVERICK (2022) .....	315
TRON (1982) .....	316 - 317
TROY (2004) .....	318 - 320
<b>V</b>	
VALLEY OF GWANGI, THE (1969) .....	114 - 117
<b>W</b>	
WES CRAVEN'S NEW NIGHTMARE (1994) .....	232
WICKER MAN, THE (1973) .....	321
WILLY WONKA AND THE CHOCOLATE FACTORY (1971) .....	321
WITHNAIL & I (1987) .....	322
<b>X</b>	
XENA: WARRIOR PRINCESS (TV. SERIES, 1995-2001) .....	324
X-FILES, THE (TV. SERIES, 1993-2002) .....	322 - 323
X-MEN (2000) .....	323





# Propstore

## Propstore Live Auction Bidder Registration Form

**Sale Name:** Entertainment Memorabilia Live Auction: London

**Sale Date:** November 14 - 17, 2024

### BIDDER INFORMATION

(If bidding as agent, complete one form as the third-party bidder and a second form as the agent. Both sets of contact information are required.)

Paddle Number (Propstore Use Only): \_\_\_\_\_ Cell Phone: \_\_\_\_\_

Name: \_\_\_\_\_ Business Phone: \_\_\_\_\_

Business Name (if applicable): \_\_\_\_\_ Fax: \_\_\_\_\_

Mailing Address (include country): \_\_\_\_\_ Email: \_\_\_\_\_

\_\_\_\_\_ Credit Card Type (Visa, MC, Discover or AmEx): \_\_\_\_\_

\_\_\_\_\_ Credit Card Number: \_\_\_\_\_

Shipping Address (include country): \_\_\_\_\_ Credit Card Expiration Date: \_\_\_\_\_

\_\_\_\_\_ Registering as (select one): Private Client  Trade Client

Company Registration No. (if applicable): \_\_\_\_\_ Reseller's Permit (if applicable): \_\_\_\_\_

Home Phone: \_\_\_\_\_

### BIDDER NOTICES - PLEASE READ

- If you wish to make a bid at a Propstore Live Auction, you must pre-register with Propstore on this form.
- If registering as an individual, you must provide Propstore with at least one (1) form of ID which must include one (1) government issued photo identification. If this does not state your current address, proof of address will also be required.
- If registering as an organization, you must provide a certified copy or original certificate of incorporation, or, in the case of unregistered entities, other evidence satisfactory to Propstore - contact Propstore at **+44 (0) 01494 766485** for confirmation or what will be acceptable.
- If you are registering as an agent to bid on behalf of another party, you must produce the relevant ID documents at paragraphs 2 and 3 above for yourself and the person or organization on whose behalf you are acting. In addition, you must provide to Propstore a written and signed authority from the third party confirming your authority to bid on their behalf.
- BY COMPLETING AND SUBMITTING THIS BIDDER REGISTRATION FORM, YOU ACKNOWLEDGE YOU HAVE READ, UNDERSTAND AND AGREE TO BE BOUND BY PROPSTORE'S LIVE AUCTION CONDITIONS OF SALE (COPIES AVAILABLE IN THE AUCTION BUYER'S GUIDE, ON PROPSTORE'S WEBSITE propstore.com OR ON REQUEST FROM PROPSTORE) AND PRIVACY POLICY (AVAILABLE ON PROPSTORE'S WEBSITE propstore.com)
- In particular, please make yourself aware of Propstore's payment terms, with all sums due within 7 calendar days of Propstore's invoice date. Propstore WILL ONLY ACCEPT PAYMENT FROM THE BUYER.

For full details on how we handle and process your data including identity and payment verification please see our website. By registering for the auction you consent to us using your personal data for this purpose including verifying the information you provide to us matches with public and other records.

**Telephone Bidders:** Telephone bidders must complete this form to provide Propstore a list of Lots on which they intend to bid at least 24 hours before the start of the auction.

**Absentee Bidders:** Written bids will be executed at the lowest possible price, taking into account the Reserve Price. Absentee Bidders must complete this form to provide Propstore with written bids at least 24 hours before the start of the Auction

Select One: Telephone Bidder  Absentee Bidder

I, the undersigned, have read and agreed to the terms and conditions of the sale, read and understood the privacy policy and am over 18 years of age

(Signature)

(Date)

**A Buyer's Premium of 26% will be added to all winning bids. Submit your completed form to support@propstore.com**

### Propstore – London Office

Stephen Lane, CEO  
Lizzie Lane, Director  
Guy Pettigrew, CFO  
Jack Coleman, Managing Director  
Tim Lawes, Director of Consignments  
Siân Taylor, Director of Operations  
Miranda McCabe, Director of Marketing  
Alex Packham, Non-Executive Director  
Cathy Dawson, Head of Group Finance  
Luke Cozens, Logistics Manager  
Viki Merry, Consignment and Auction Administration Manager  
Sarah Sorkin, Photography & Video Manager  
Paul Wallis, Facilities & IT Manager  
Graham Terry, Warehouse Manager  
Chris Aikman, Copywriting Manager  
Ibrahim Faraj, Consignments Manager  
Devon Cozens, Finance Senior Administrator  
Jamie Dalton, Senior Client Services Lead  
Katie Males, Copywriter & Researcher: Music & Posters  
Ellie Tribe, Copywriter & Researcher  
Matthew Allen, Copywriter & Researcher  
George Dupree, Photographer & Videographer  
Robert Aikman, Photographer & Assistant Videographer  
Melody Liu, Video & Graphic Designer  
Kelly Stokes, Graphic Designer  
Nidhi Vaze, Marketing Assistant  
Tyma Idriss, Social Media & Press Associate  
Richard Airey, Shipping Assistant  
Matt Storey, General Assistant  
Sam Dietz, General Assistant  
Mark Hochman, Music & Poster Consultant

**Telephone – +44 (0) 01494 766485**

**Email – support@propstore.com**

### Propstore – Los Angeles Office

Brandon Alinger, Global COO & President, North America  
Chuck Costas, VP, Business Development and Marketing  
Greg Giroux, VP, IT Development  
Don Barnett, Director of Operations  
Art Andrews, Director of Consignments  
Maegan Hensley, Director of Asset Management  
Grey Smith, Director of Consignments, Posters  
Dan Hill, Senior Manager, Consignments  
Justin Miller, Senior Manager, Photography  
Jamie Jamitkowski, Senior Manager, Marketing  
Anthony Gonzalez, Manager, Graphic Design  
Tami Garcia, Finance & Administration Manager  
Sean L. Malin, Copy Manager  
Jim Mossey, Sourcing Manager, Consignments  
Noel Rocha, Jr. Analyst, Consignments Administrative  
Joe Beaudoin, Jr. Analyst, Buy Now  
Zachary Hyzy, Data Analysis Supervisor  
John Hillman, Poster Consignments Supervisor  
Paul Springer, Poster Consignments Assistant  
Paul Gonzalez, Warehouse Supervisor  
Charles Warr, Supervisor, Video, Tech Production & Graphics  
Kellina James, Assistant Supervisor, Graphics  
Jaret Sears, Assistant Supervisor, Copywriting  
Raeann Briones-Almaguer, Copy Associate  
Rachel Herbert, Copy Associate  
Lauren Shand, Jr. Assistant, Consignments Lead Generation  
Wendy Allen, Sr. Associate, Consignment Warehouse  
Jarrod Kirkness, Jr. Assistant, Consignments Goods-In  
Christy Andrews, Jr. Assistant, Consignments Research  
Kiley Bishop, Photographer  
Lori Sandoval, Photographer  
Antonia Fox, Photography Assistant  
Cameron Rookey, Photography Assistant  
Devin Lotfi, Photography Associate  
Ryan Gibson, Customer Service & Administration, Coordinator  
Adam Woodring, Shipping Associate  
Vincent Lorentz, Shipping Assistant  
Jonathan Robles Ortega, Shipping Assistant  
Brennan Mann, Warehouse Associate  
Fernando Lomeli, Intake Assistant  
Sean McBride, Warehouse Assistant

**Telephone – +1 818-727-7829**

**Email – supportla@propstore.com**

### BACK COVER IMAGES

**205**  
Howard Kazanjian  
Collection: Rene  
Belloq's (Paul  
Freeman) Ceremonial  
Staff Ω  
**Indiana Jones And  
The Raiders Of The  
Lost Ark (1981)**

**363**  
Screen-matched Stormtrooper (Sandtrooper)  
Helmet from Jedi Mind Trick Scene  
("Move Along, Move Along") M  
**Star Wars: A New Hope (1977)**

**226**  
Hand-painted Robert McGinnis Poster Art Ω  
**James Bond: Diamonds Are Forever (1971)**

### Catalog Creative Team

**Designers:**  
Anthony Gonzalez, Kellina James, Sarah Cierlak, Wade Lageose, Tony Mendoza

**Photographers:**  
Justin Miller, Lori Sandoval, Kiley Bishop, Antonia Fox, Cameron Rookey, Devin Lotfi, Sarah Sorkin, George Dupree, Robert Aikman

**Copywriters:**  
Sean L. Malin, Jaret Sears, Rachel Herbert, Raeann Briones-Almaguer, Chris Aikman, Katie Males, Matt Allen, Ellie Tribe

**Editor:** Shelley Moench-Kelly, Dan Jolin  
**Researchers:** Christy Andrews, Joe Beaudoin, Scott Kaufmann





# DARK CRYSTAL

